



# FCC RF Test Report

**APPLICANT** : Motorola Mobility, LLC  
**EQUIPMENT** : Mobile Cellular Phone  
**BRAND NAME** : Motorola  
**MODEL NAME** : 4036  
**FCC ID** : IHDT56UA1  
**STANDARD** : FCC 47 CFR Part 2, 22(H), 24(E)  
**CLASSIFICATION** : PCS Licensed Transmitter Held to Ear (PCE)

The product was received on May 20, 2015 and testing was completed on Jun. 17, 2015. We, SPORTON INTERNATIONAL INC., would like to declare that the tested sample has been evaluated in accordance with the test procedures given in ANSI / TIA / EIA-603-C-2004 and has been in compliance with the applicable technical standards.

The test results in this report apply exclusively to the tested model / sample. Without written approval of SPORTON INTERNATIONAL INC., the test report shall not be reproduced except in full.

Reviewed by: Joseph Lin / Supervisor

Approved by: Jones Tsai / Manager



## SPORTON INTERNATIONAL INC.

No. 52, Hwa Ya 1<sup>st</sup> Rd., Hwa Ya Technology Park, Kwei-Shan District, Tao Yuan City, Taiwan, R.O.C.



# TABLE OF CONTENTS

**REVISION HISTORY..... 3**

**SUMMARY OF TEST RESULT ..... 4**

**1 GENERAL DESCRIPTION ..... 5**

    1.1 Applicant..... 5

    1.2 Manufacturer ..... 5

    1.3 Product Feature of Equipment Under Test ..... 5

    1.4 Product Specification subjective to this standard ..... 6

    1.5 Modification of EUT ..... 6

    1.6 Maximum ERP/EIRP Power, Frequency Tolerance, and Emission Designator ..... 7

    1.7 Testing Location ..... 8

    1.8 Applicable Standards ..... 8

**2 TEST CONFIGURATION OF EQUIPMENT UNDER TEST ..... 9**

    2.1 Test Mode..... 9

    2.2 Connection Diagram of Test System ..... 12

    2.3 Support Unit used in test configuration ..... 13

    2.4 Measurement Results Explanation Example ..... 13

**3 TEST RESULT ..... 14**

    3.1 Conducted Output Power Measurement..... 14

    3.2 Peak-to-Average Ratio ..... 17

    3.3 Effective Radiated Power and Effective Isotropic Radiated Power Measurement ..... 40

    3.4 99% Occupied Bandwidth and 26dB Bandwidth Measurement..... 46

    3.5 Band Edge Measurement..... 79

    3.6 Conducted Spurious Emission Measurement ..... 90

    3.7 Field Strength of Spurious Radiation Measurement ..... 121

    3.8 Frequency Stability Measurement..... 159

**4 LIST OF MEASURING EQUIPMENT ..... 166**

**5 UNCERTAINTY OF EVALUATION ..... 167**





### SUMMARY OF TEST RESULT

Report Section	FCC Rule	Description	Limit	Result	Remark
3.1	§2.1046	Conducted Output Power	Reporting Only	PASS	-
3.2	§24.232(d)	Peak-to-Average Ratio	<13 dB	PASS	-
3.3	§22.913(a)(2)	Effective Radiated Power	< 7 Watts	PASS	-
	§24.232(c)	Equivalent Isotropic Radiated Power	< 2 Watts	PASS	-
3.4	§2.1049	Occupied Bandwidth	Reporting Only	PASS	-
3.5	§2.1051	Band Edge Measurement	< 43+10log <sub>10</sub> (P[Watts])	PASS	-
	§22.917(a) §24.238(a)				
3.6	§2.1051	Conducted Spurious Emission	< 43+10log <sub>10</sub> (P[Watts])	PASS	-
	§22.917(a) §24.238(a)				
3.7	§2.1053	Field Strength of Spurious Radiation	< 43+10log <sub>10</sub> (P[Watts])	PASS	Under limit 15.68 dB at 3819.000 MHz
	§22.917(a) §24.238(a)				
3.8	§2.1055	Frequency Stability for Temperature & Voltage	< 2.5 ppm for Part 22 Within Authorized Band	PASS	-
	§22.355 §2.1055 §24.235				



# 1 General Description

## 1.1 Applicant

Motorola Mobility, LLC

222 W Merchandise Mart Plaza, Suite 1800, Chicago, IL 60654, United States

## 1.2 Manufacturer

Motorola Mobility, LLC

222 W Merchandise Mart Plaza, Suite 1800, Chicago, IL 60654, United States

## 1.3 Product Feature of Equipment Under Test

Product Feature	
Equipment	Mobile Cellular Phone
Brand Name	Motorola
Model Name	4036
FCC ID	IHDT56UA1
IMEI Code	990005740001756
EUT supports Radios application	CDMA/EV-DO/GSM/EGPRS/WCDMA/HSPA/LTE/NFC 2.4GHz WLAN 11b/g/n HT20 WLAN 11ac VHT20 5GHz WLAN 11a/n HT20/HT40 WLAN 11ac VHT20/VHT40/VHT80 Bluetooth v3.0 EDR Bluetooth v4.1 - LE
HW Version	P2
EUT Stage	Identical Prototype

Remark: The above EUT's information was declared by manufacturer. Please refer to the specifications or user's manual for more detailed description.

Accessory List	
AC Adapter	Brand Name : Motorola
	Model Name : SPN5886A
Battery	Brand Name : Motorola
	Model Name : FB55
Earphone	Brand Name : Motorola
	Model Name : 89719N



### 1.4 Product Specification subjective to this standard

Product Specification subjective to this standard	
<b>Tx Frequency</b>	GSM850: 824.2 MHz ~ 848.8 MHz GSM1900: 1850.2 MHz ~ 1909.8MHz WCDMA Band V: 826.4 MHz ~ 846.6 MHz WCDMA Band II: 1852.4 MHz ~ 1907.6 MHz CDMA2000 BC0: 824.70 MHz ~ 848.31 MHz CDMA2000 BC1: 1851.25 MHz ~ 1908.75 MHz
<b>Rx Frequency</b>	GSM850: 869.2 MHz ~ 893.8 MHz GSM1900: 1930.2 MHz ~ 1989.8 MHz WCDMA Band V: 871.4 MHz ~ 891.6 MHz WCDMA Band II: 1932.4 MHz ~ 1987.6 MHz CDMA2000 BC0: 869.70 MHz ~ 893.31 MHz CDMA2000 BC1: 1931.25 MHz ~ 1988.75 MHz
<b>Maximum Output Power to Antenna</b>	GSM850 : 32.68 dBm GSM1900 : 29.50 dBm WCDMA Band V : 22.62 dBm WCDMA Band II : 22.91 dBm CDMA2000 BC0 : 24.07 dBm CDMA2000 BC1 : 23.75 dBm
<b>Antenna Type</b>	Fixed Internal Antenna
<b>Type of Modulation</b>	GSM: GMSK GPRS: GMSK EDGE: GMSK / 8PSK WCDMA: QPSK (Uplink) HSDPA: 64QAM (Downlink) HSUPA: QPSK (Uplink) CDMA2000 : QPSK CDMA2000 1xEV-DO : QPSK/8PSK

### 1.5 Modification of EUT

No modifications are made to the EUT during all test items.



### 1.6 Maximum ERP/EIRP Power, Frequency Tolerance, and Emission Designator

FCC Rule	System	Type of Modulation	Maximum ERP/EIRP (W)	Frequency Tolerance (ppm)	Emission Designator
Part 22	GSM850 GPRS class 8	GMSK	0.6607	0.0120 ppm	247KGXW
Part 22	GSM850 EDGE class 8	8PSK	0.1611	0.0143 ppm	241KG7W
Part 22	WCDMA Band V RMC 12.2Kbps	QPSK	0.0839	0.0120 ppm	4M15F9W
Part 22	CDMA2000 BC0 1xRTT	QPSK	0.1758	0.0203 ppm	1M28F9W
Part 22	CDMA2000 BC0 1xEV-DO Rev. 0	QPSK	0.1387	0.0203 ppm	1M28F9W
Part 24	GSM1900 GPRS class 8	GMSK	1.5346	0.0128 ppm	246KGXW
Part 24	GSM1900 EDGE class 8	8PSK	0.7691	0.0144 ppm	244KG7W
Part 24	WCDMA Band II RMC 12.2Kbps	QPSK	0.3954	0.0074 ppm	4M16F9W
Part 24	CDMA2000 BC1 1xRTT	QPSK	0.3926	0.0239 ppm	1M28F9W
Part 24	CDMA2000 BC1 1xEV-DO Rev. 0	QPSK	0.4009	0.0298 ppm	1M28F9W



### 1.7 Testing Location

Sporton Lab is accredited to ISO 17025 by Taiwan Accreditation Foundation (TAF code : 1190) and the FCC designation No. TW1022 under the FCC 2.948(e) by Mutual Recognition Agreement (MRA) in FCC Test.

<b>Test Site</b>	SPORTON INTERNATIONAL INC.
<b>Test Site Location</b>	No. 52, Hwa Ya 1 <sup>st</sup> Rd., Hwa Ya Technology Park, Kwei-Shan District, Tao Yuan City, Taiwan, R.O.C. TEL: +886-3-327-3456 FAX: +886-3-328-4978
<b>Test Site No.</b>	<b>Sporton Site No.</b>
	TH03-HY

<b>Test Site</b>	SPORTON INTERNATIONAL INC.
<b>Test Site Location</b>	No.58, Aly. 75, Ln. 564, Wenhua 3rd Rd. Guishan Township, Taoyuan County, Taiwan (R.O.C.) TEL: +886-3-327-0855
<b>Test Site No.</b>	<b>Sporton Site No.</b>
	03CH11-HY

### 1.8 Applicable Standards

According to the specifications of the manufacturer, the EUT must comply with the requirements of the following standards:

- ♦ FCC 47 CFR Part 2, 22(H), 24(E)
- ♦ ANSI / TIA / EIA-603-C-2004
- ♦ FCC KDB 971168 D01 Power Meas. License Digital Systems v02r02
- ♦ KDB 648474 D03 Handset Wireless Chargers Battery Covers v01r02

**Remark:**

1. All test items were verified and recorded according to the standards and without any deviation during the test.
2. This EUT has also been tested and complied with the requirements of FCC Part 15, Subpart B, recorded in a separate test report.



## 2 Test Configuration of Equipment Under Test

### 2.1 Test Mode

Antenna port conducted and radiated test items were performed according to KDB 971168 D01 Power Meas. License Digital Systems v02r02 with maximum output power.

Radiated measurements were performed with rotating EUT in different three orthogonal test planes to find the maximum emission.

Radiated emissions were investigated as following frequency range:

1. 30 MHz to 9000 MHz for GSM850, WCDMA Band V, and CDMA2000 BC0.
2. 30 MHz to 19000 MHz for GSM1900, WCDMA Band II, and CDMA2000 BC1.

All modes and data rates and positions were investigated.

Test modes are chosen to be reported as the worst case configuration below:

Test Modes		
Band	Radiated TCs	Conducted TCs
GSM 850	<ul style="list-style-type: none"> <li>■ GPRS class 8 Link</li> <li>■ EDGE class 8 Link</li> </ul>	<ul style="list-style-type: none"> <li>■ GPRS class 8 Link</li> <li>■ EDGE class 8 Link</li> </ul>
GSM 1900	<ul style="list-style-type: none"> <li>■ GPRS class 8 Link</li> <li>■ EDGE class 8 Link</li> </ul>	<ul style="list-style-type: none"> <li>■ GPRS class 8 Link</li> <li>■ EDGE class 8 Link</li> </ul>
WCDMA Band V	<ul style="list-style-type: none"> <li>■ RMC 12.2Kbps Link</li> </ul>	<ul style="list-style-type: none"> <li>■ RMC 12.2Kbps Link</li> </ul>
WCDMA Band II	<ul style="list-style-type: none"> <li>■ RMC 12.2Kbps Link</li> </ul>	<ul style="list-style-type: none"> <li>■ RMC 12.2Kbps Link</li> </ul>
CDMA2000 BC0	<ul style="list-style-type: none"> <li>■ 1xRTT Link Mode</li> <li>■ 1xEV-DO Rev. 0 Link Mode</li> </ul>	<ul style="list-style-type: none"> <li>■ 1xRTT Link Mode</li> <li>■ 1xEV-DO Rev. 0 Link Mode</li> </ul>
CDMA2000 BC1	<ul style="list-style-type: none"> <li>■ 1xRTT Link Mode</li> <li>■ 1xEV-DO Rev. 0 Link Mode</li> </ul>	<ul style="list-style-type: none"> <li>■ 1xRTT Link Mode</li> <li>■ 1xEV-DO Rev. 0 Link Mode</li> </ul>

**Note:** The maximum power levels are chosen to test as the worst case configuration as follows:

GPRS multi-slot class 8 mode for GMSK modulation,

EDGE multi-slot class 8 mode for 8PSK modulation,

RMC 12.2Kbps mode for WCDMA band V and WCDMA band II,

1xRTT RC1 SO55 and 1xEVDO RTAP 153.6Kbps mode for CDMA2000 BC0 and CDMA2000 BC1,

only these modes were used for all tests. In addition to above worst-case test, below investigating on all data rates, and all modes are compliance with each FCC test case which has specific test limits. For spurious emissions at antenna port, the EUT was investigated the band edges on low and high channels, and the unwanted spurious emissions on middle channel for all modes, the results are pass, then only the worst-results were reported in the test report. The Radiated Spurious emissions for GSM/GPRS/EGPRS/HSDPA/CDMA modes were investigated



on the middle channel and the passed results were not worse than those data tested from the highest power channels.

All the test modes were tested with WPC Charger in the Radiated test item. And the worst mode was verified with PMA and AC Adapter.



Conducted Power Measurement Results:

Conducted Power (*Unit: dBm)						
Band	GSM850			GSM1900		
Channel	128	189	251	512	661	810
Frequency	824.2	836.4	848.8	1850.2	1880.0	1909.8
GSM	32.33	32.67	32.65	29.30	29.48	29.36
GPRS class 8	32.36	32.68	32.67	29.33	29.50	29.36
GPRS class 10	29.03	29.06	29.25	26.36	26.32	26.07
GPRS class 11	27.40	27.49	27.28	24.29	24.28	24.36
GPRS class 12	26.03	26.07	26.13	23.13	23.07	23.08
EGPRS class 8	26.27	26.31	26.29	25.29	25.12	25.06
EGPRS class 10	23.81	23.76	23.74	24.27	24.11	24.08
EGPRS class 11	23.12	23.11	23.10	21.52	21.28	21.19
EGPRS class 12	21.70	21.72	21.68	20.16	19.95	19.88

Conducted Power (*Unit: dBm)						
Band	WCDMA Band V			WCDMA Band II		
Channel	4132	4182	4233	9262	9400	9538
Frequency	826.4	836.4	846.6	1852.4	1880.0	1907.6
RMC 12.2K	22.62	22.59	22.51	22.58	22.75	22.91
HSDPA Subtest-1	21.48	21.52	21.55	21.48	21.63	21.82
HSDPA Subtest-2	21.61	21.59	21.56	21.44	21.61	21.73
HSDPA Subtest-3	21.08	21.15	21.07	20.94	21.12	21.35
HSDPA Subtest-4	21.07	21.14	21.03	20.90	21.02	21.21
HSUPA Subtest-1	21.28	21.18	21.17	21.04	21.25	21.38
HSUPA Subtest-2	20.58	20.54	20.57	20.03	20.28	20.41
HSUPA Subtest-3	20.42	20.47	20.45	20.31	20.46	20.62
HSUPA Subtest-4	20.94	20.96	20.88	20.79	20.83	20.93
HSUPA Subtest-5	21.57	21.59	21.52	21.33	21.50	21.76

Conducted Power (*Unit: dBm)						
Band	CDMA2000 BC0			CDMA2000 BC1		
Channel	1013	384	777	25	600	1175
Frequency	824.7	836.52	848.31	1851.25	1880	1908.75
1xRTT RC1 SO55	23.84	24.07	24.02	23.67	23.65	23.75
1xRTT RC3 SO55	23.81	24.05	24.00	23.65	23.63	23.71
1xRTT RC3 SO32(+ F-SCH)	23.80	24.04	23.98	23.66	23.64	23.70
1xRTT RC3 SO32(+SCH)	23.84	24.06	24.02	23.67	23.64	23.72
1xEV-DO RTAP 153.6kbps	23.82	24.06	24.00	23.68	23.65	23.74
1xEV-DO RETAP 4096Bits	23.66	23.91	23.86	23.64	23.61	23.70

## 2.2 Connection Diagram of Test System

### <EUT with Adapter>

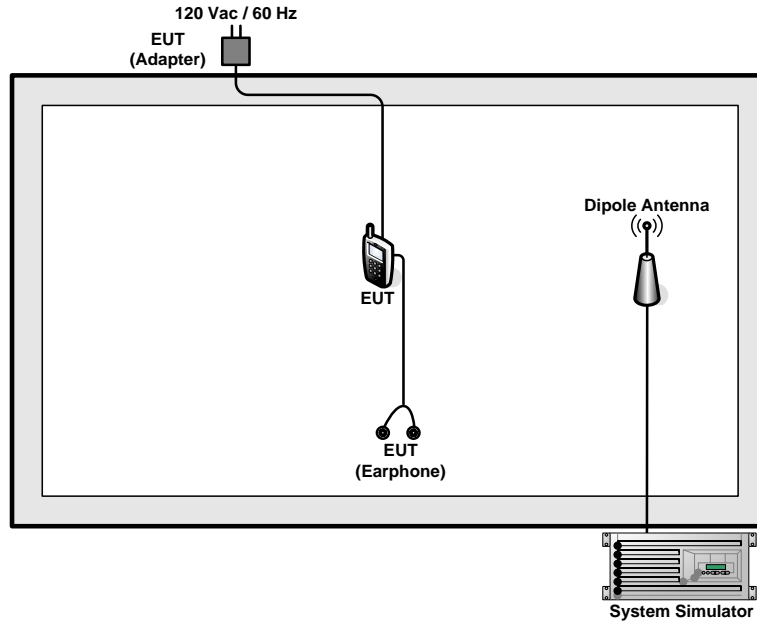

### <EUT with WPC Charger / PMA>

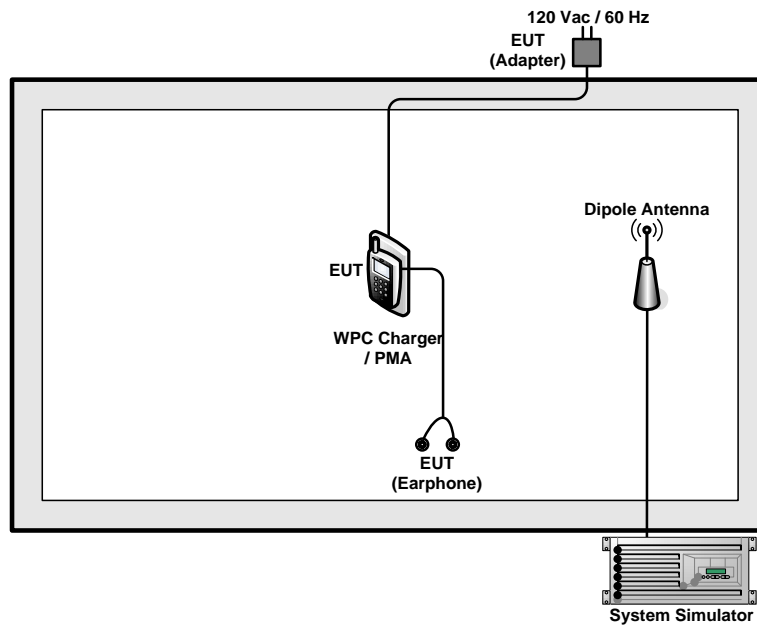



### 2.3 Support Unit used in test configuration

Item	Equipment	Trade Name	Model No.	FCC ID	Data Cable	Power Cord
1.	System Simulator	Anritsu	MT8820C	N/A	N/A	Unshielded, 1.8 m
2.	WPC Charger	Samsung	EP-P1001EWE	A3LEPP100IJWU	N/A	N/A
3.	PMA	Duracell Powermat	M-C 18B-518A	N/A	N/A	N/A
4.	Adapter(PMA)	POWER MAT	KSAP0151800083D5	N/A	N/A	Unshielded, 1.5 m

### 2.4 Measurement Results Explanation Example

**For all conducted test items:**

The offset level is set in the spectrum analyzer to compensate the RF cable loss and attenuator factor between RF conducted output port and spectrum analyzer. With the offset compensation, the spectrum analyzer reading level will be exactly the RF output level.

The spectrum analyzer offset is derived from RF cable loss and attenuator factor.

$$\text{Offset} = \text{RF cable loss} + \text{attenuator factor}.$$

The following shows an offset computation example with RF cable loss 4.2 dB and a 10dB attenuator.

Example :

$$\begin{aligned} \text{Offset(dB)} &= \text{RF cable loss(dB)} + \text{attenuator factor(dB)}. \\ &= 4.2 + 10 = 14.2 \text{ (dB)} \end{aligned}$$

### **3 Test Result**

#### **3.1 Conducted Output Power Measurement**

##### **3.1.1 Description of the Conducted Output Power Measurement**

A system simulator was used to establish communication with the EUT. Its parameters were set to enforce EUT transmitting at the maximum power. The measured power in the radio frequency on the transmitter output terminals shall be reported.

##### **3.1.2 Measuring Instruments**

The measuring equipment is listed in the section 4 of this test report.

##### **3.1.3 Test Procedures**

1. The transmitter output port was connected to the system simulator.
2. Set EUT at maximum power through system simulator.
3. Select lowest, middle, and highest channels for each band and different modulation.
4. Measure the maximum burst average power for GSM and maximum average power for other modulation signal.

##### **3.1.4 Test Setup**

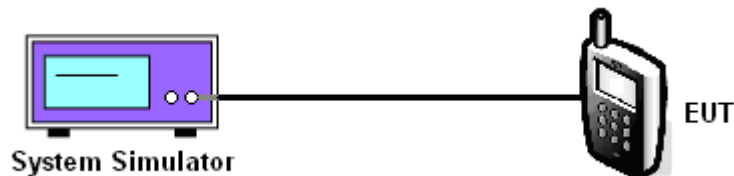



3.1.5 Test Result of Conducted Output Power

Cellular Band									
Modes	GSM850 (GPRS class 8)			GSM850 (EDGE class 8)			WCDMA Band V (RMC 12.2Kbps)		
Channel	128 (Low)	189 (Mid)	251 (High)	128 (Low)	189 (Mid)	251 (High)	4132 (Low)	4182 (Mid)	4233 (High)
Frequency (MHz)	824.2	836.4	848.8	824.2	836.4	848.8	826.4	836.4	846.6
Conducted Power (dBm)	32.36	32.68	32.67	26.27	26.31	26.29	22.62	22.59	22.51

PCS Band									
Modes	GSM1900 (GPRS class 8)			GSM1900 (EDGE class 8)			WCDMA Band II (RMC 12.2Kbps)		
Channel	512 (Low)	661 (Mid)	810 (High)	512 (Low)	661 (Mid)	810 (High)	9262 (Low)	9400 (Mid)	9538 (High)
Frequency (MHz)	1850.2	1880	1909.8	1850.2	1880	1909.8	1852.4	1880	1907.6
Conducted Power (dBm)	29.33	29.50	29.36	25.29	25.12	25.06	22.58	22.75	22.91

CDMA2000 BC0			
Test Mode	CDMA 2000 1xRTT		
Test Status	RC1+SO55		
Channel	1013 (Low)	384 (Mid)	777 (High)
Frequency (MHz)	824.70	836.52	848.31
Conducted Power (dBm)	23.84	24.07	24.02

CDMA2000 BC0			
Test Mode	CDMA 2000 1xEV-DO Rev. 0		
Test Status	RTAP 153.6K		
Channel	1013 (Low)	384 (Mid)	777 (High)
Frequency (MHz)	824.70	836.52	848.31
Conducted Power (dBm)	23.82	24.06	24.00



CDMA2000 BC1			
Test Mode	CDMA 2000 1xRTT		
Test Status	RC1+SO55		
Channel	25 (Low)	600 (Mid)	1175 (High)
Frequency (MHz)	1851.25	1880.00	1908.75
Conducted Power (dBm)	23.67	23.65	23.75

CDMA2000 BC1			
Test Mode	CDMA 2000 1xEV-DO Rev. 0		
Test Status	RTAP 153.6K		
Channel	25 (Low)	600 (Mid)	1175 (High)
Frequency (MHz)	1851.25	1880.00	1908.75
Conducted Power (dBm)	23.68	23.65	23.74

**Note:** maximum burst average power for GPRS, and maximum average power for WCDMA and CDMA2000.

## 3.2 Peak-to-Average Ratio

### 3.2.1 Description of the PAR Measurement

The peak-to-average ratio (PAR) of the transmission may not exceed 13 dB.

### 3.2.2 Measuring Instruments

The measuring equipment is listed in the section 4 of this test report.

### 3.2.3 Test Procedures

1. The testing follows FCC KDB 971168 v02r02 Section 5.7.1.
1. The EUT was connected to spectrum analyzer and system simulator via a power divider.
2. Set EUT to transmit at maximum output power.
3. When the duty cycle is less than 98%, then signal gating will be implemented on the spectrum analyzer by triggering from the system simulator.
4. Set the CCDF (Complementary Cumulative Distribution Function) option of the spectrum analyzer.  
Record the maximum PAPR level associated with a probability of 0.1%.

### 3.2.4 Test Setup

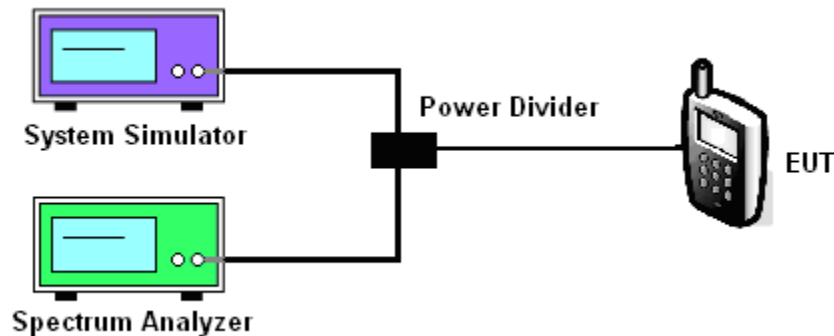



3.2.5 Test Result of Peak-to-Average Ratio

Cellular Band									
Modes	GSM850 (GPRS class 8)			GSM850 (EDGE class 8)			WCDMA Band V (RMC 12.2Kbps)		
Channel	128 (Low)	189 (Mid)	251 (High)	128 (Low)	189 (Mid)	251 (High)	4132 (Low)	4182 (Mid)	4233 (High)
Frequency (MHz)	824.2	836.4	848.8	824.2	836.4	848.8	826.4	836.4	846.6
Peak-to-Average Ratio (dB)	0.28	0.28	0.24	3.16	3.40	3.32	3.28	3.56	3.24

PCS Band									
Modes	GSM1900 (GPRS class 8)			GSM1900 (EDGE class 8)			WCDMA Band II (RMC 12.2Kbps)		
Channel	512 (Low)	661 (Mid)	810 (High)	512 (Low)	661 (Mid)	810 (High)	9262 (Low)	9400 (Mid)	9538 (High)
Frequency (MHz)	1850.2	1880	1909.8	1850.2	1880	1909.8	1852.4	1880	1907.6
Peak-to-Average Ratio (dB)	0.24	0.28	0.28	3.32	3.20	3.24	3.12	3.28	3.28

CDMA2000 BC0			
Modes	CDMA 2000 1xRTT		
Test Status	RC1+SO55		
Channel	1013 (Low)	384 (Mid)	777 (High)
Frequency (MHz)	824.70	836.52	848.31
Peak-to-Average Ratio (dB)	4.40	4.92	4.40

CDMA2000 BC0			
Modes	CDMA 2000 1xEV-DO Rev. 0		
Test Status	RTAP 153.6K		
Channel	1013 (Low)	384 (Mid)	777 (High)
Frequency (MHz)	824.70	836.52	848.31
Peak-to-Average Ratio (dB)	4.44	4.96	4.44



CDMA2000 BC1			
Modes	CDMA 2000 1xRTT		
Test Status	RC1+SO55		
Channel	25 (Low)	600 (Mid)	1175 (High)
Frequency (MHz)	1851.25	1880.00	1908.75
Peak-to-Average Ratio (dB)	4.24	4.08	3.68

CDMA2000 BC1			
Modes	CDMA 2000 1xEV-DO Rev. 0		
Test Status	RTAP 153.6K		
Channel	25 (Low)	600 (Mid)	1175 (High)
Frequency (MHz)	1851.25	1880.00	1908.75
Peak-to-Average Ratio (dB)	4.12	4.00	3.56



### 3.2.6 Test Result (Plots) of Peak-to-Average Ratio

Band :	GSM 850	Test Mode :	GPRS class 8 Link (GMSK)
--------	---------	-------------	--------------------------

#### Peak-to-Average Ratio on Channel 128 (824.2 MHz)

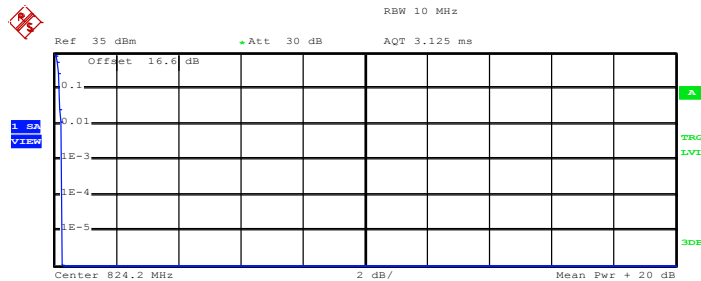

Complementary Cumulative Distribution Function (100000 samples)

Trace 1  
 Mean 27.83 dBm  
 Peak 28.09 dBm  
 Crest 0.27 dB

10 %	0.20 dB
1 %	0.24 dB
.1 %	0.28 dB
.01 %	0.28 dB

Date: 16.JUN.2015 13:50:43

#### Peak-to-Average Ratio on Channel 189 (836.4 MHz)

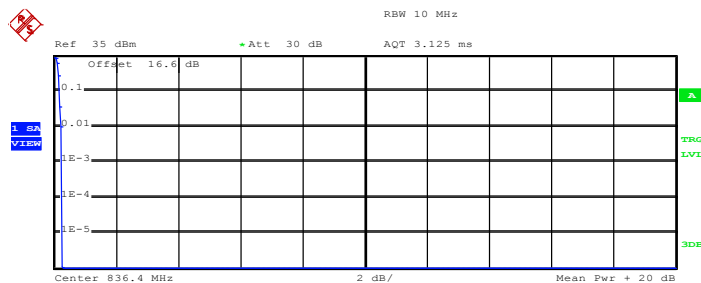

Complementary Cumulative Distribution Function (100000 samples)

Trace 1  
 Mean 28.19 dBm  
 Peak 28.45 dBm  
 Crest 0.25 dB

10 %	0.20 dB
1 %	0.24 dB
.1 %	0.28 dB
.01 %	0.28 dB

Date: 16.JUN.2015 13:51:13



Peak-to-Average Ratio on Channel 251 (848.8 MHz)

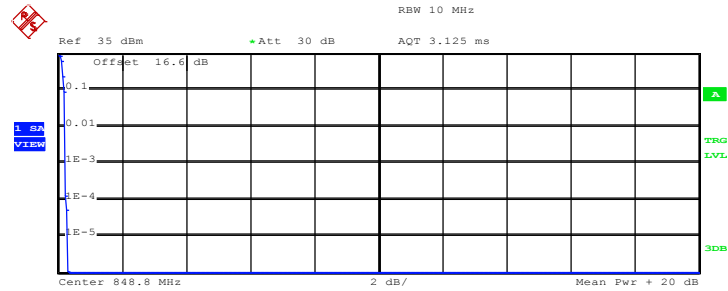

Complementary Cumulative Distribution Function (100000 samples)

Trace 1

Mean    28.49 dBm  
Peak    28.80 dBm  
Crest    0.31 dB

10 %    0.20 dB  
1 %    0.24 dB  
.1 %    0.24 dB  
.01 %    0.24 dB

Date: 16.JUN.2015 13:51:37



<b>Band :</b>	GSM 850	<b>Test Mode :</b>	EDGE class 8 Link (8PSK)
---------------	---------	--------------------	--------------------------

**Peak-to-Average Ratio on Channel 128 (824.2 MHz)**

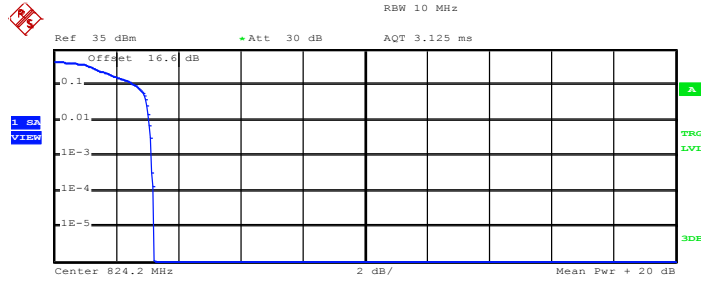

Complementary Cumulative Distribution Function (100000 samples)

Trace 1

Mean	23.18 dBm
Peak	26.40 dBm
Crest	3.22 dB
10 %	2.64 dB
1 %	3.08 dB
.1 %	3.16 dB
.01 %	3.20 dB

Date: 16.JUN.2015 14:05:15

**Peak-to-Average Ratio on Channel 189 (836.4 MHz)**

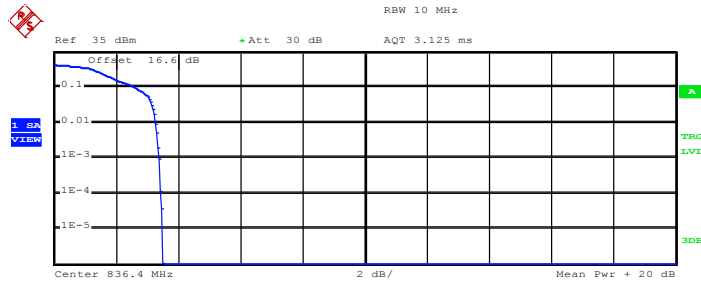

Complementary Cumulative Distribution Function (100000 samples)

Trace 1

Mean	23.19 dBm
Peak	26.68 dBm
Crest	3.49 dB
10 %	2.64 dB
1 %	3.28 dB
.1 %	3.40 dB
.01 %	3.44 dB

Date: 16.JUN.2015 14:05:27



Peak-to-Average Ratio on Channel 251 (848.8 MHz)

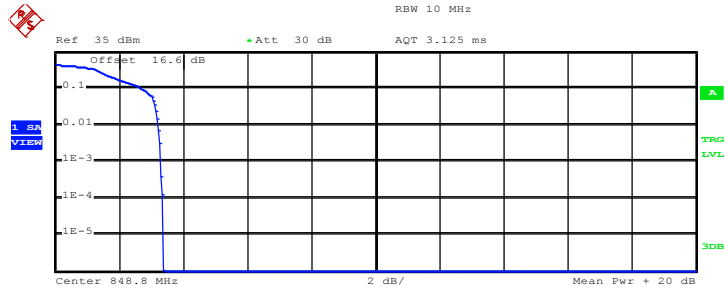

Complementary Cumulative Distribution Function (100000 samples)

Trace 1  
 Mean 23.51 dBm  
 Peak 26.90 dBm  
 Crest 3.39 dB

10 %	2.72 dB
1 %	3.24 dB
.1 %	3.32 dB
.01 %	3.36 dB

Date: 16.JUN.2015 14:05:39



<b>Band :</b>	GSM 1900	<b>Test Mode :</b>	GPRS class 8 Link (GMSK)
---------------	----------	--------------------	--------------------------

Peak-to-Average Ratio on Channel 512 (1850.2 MHz)

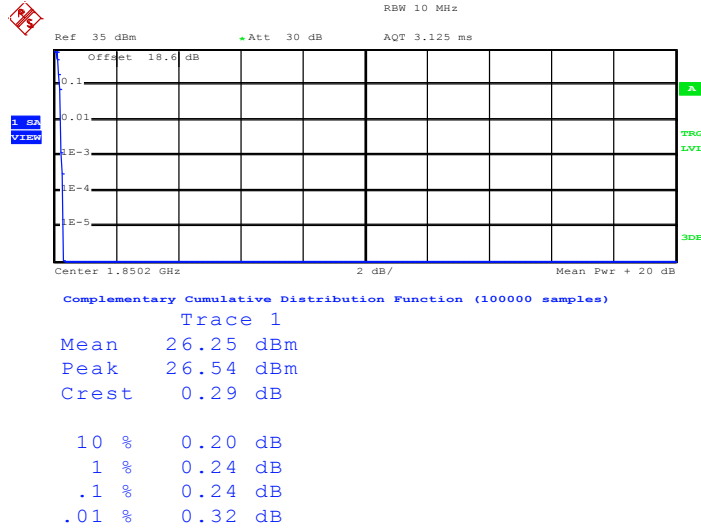

Date: 16.JUN.2015 14:27:57

Peak-to-Average Ratio on Channel 661 (1880.0 MHz)

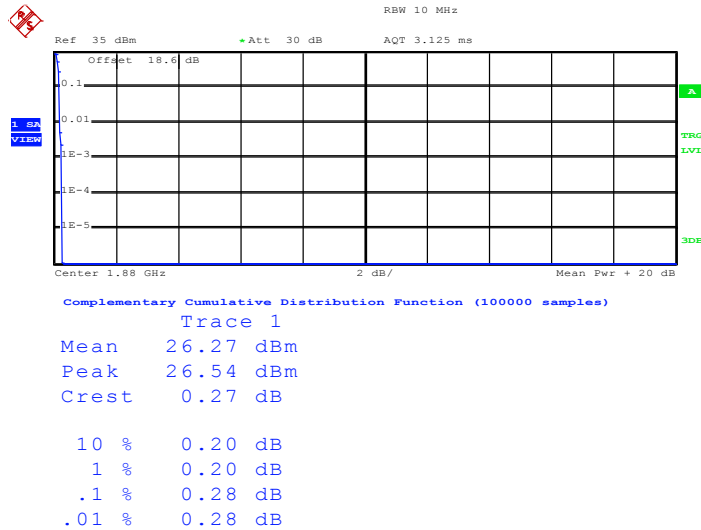

Date: 16.JUN.2015 14:28:07



Peak-to-Average Ratio on Channel 810 (1909.8 MHz)

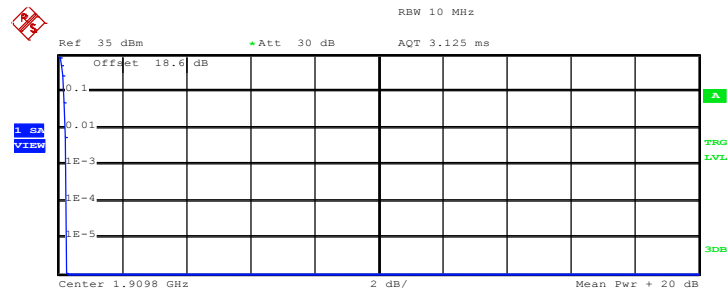

Complementary Cumulative Distribution Function (100000 samples)

Trace 1

Mean 25.91 dBm  
 Peak 26.19 dBm  
 Crest 0.28 dB

10 % 0.20 dB  
 1 % 0.24 dB  
 .1 % 0.28 dB  
 .01 % 0.28 dB

Date: 16.JUN.2015 14:28:18



<b>Band :</b>	GSM 1900	<b>Test Mode :</b>	EDGE class 8 Link (8PSK)
---------------	----------	--------------------	--------------------------

**Peak-to-Average Ratio on Channel 512 (1850.2 MHz)**

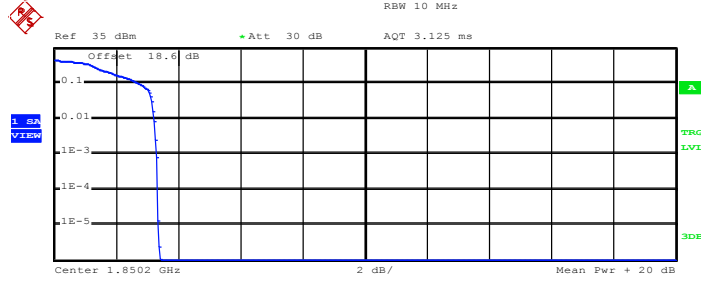

Complementary Cumulative Distribution Function (100000 samples)

Trace 1

Mean	24.34 dBm
Peak	27.74 dBm
Crest	3.40 dB
10 %	2.76 dB
1 %	3.24 dB
.1 %	3.32 dB
.01 %	3.36 dB

Date: 16.JUN.2015 14:38:09

**Peak-to-Average Ratio on Channel 661 (1880.0 MHz)**

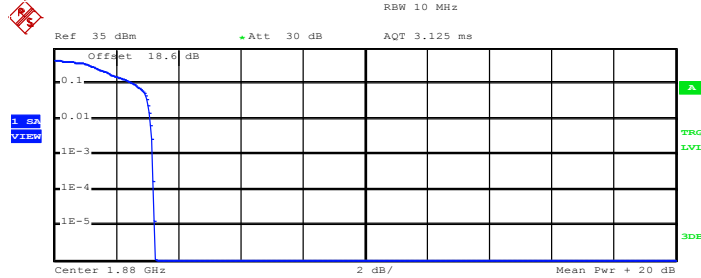

Complementary Cumulative Distribution Function (100000 samples)

Trace 1

Mean	24.26 dBm
Peak	27.53 dBm
Crest	3.27 dB
10 %	2.60 dB
1 %	3.12 dB
.1 %	3.20 dB
.01 %	3.20 dB

Date: 16.JUN.2015 14:38:22



Peak-to-Average Ratio on Channel 810 (1909.8 MHz)

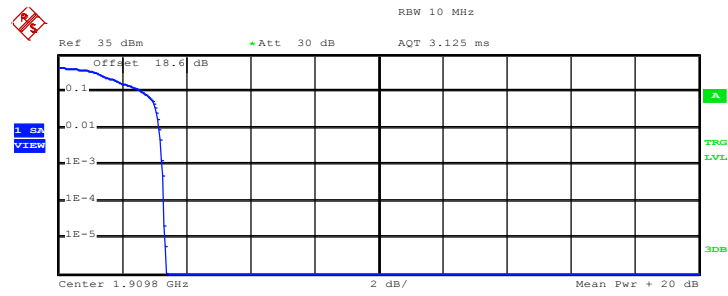

Complementary Cumulative Distribution Function (100000 samples)

Trace 1

Mean	23.88 dBm
Peak	27.25 dBm
Crest	3.37 dB
10 %	2.64 dB
1 %	3.16 dB
.1 %	3.24 dB
.01 %	3.32 dB

Date: 16.JUN.2015 14:38:37



<b>Band :</b>	WCDMA Band V	<b>Test Mode :</b>	RMC 12.2Kbps Link (QPSK)
---------------	--------------	--------------------	--------------------------

**Peak-to-Average Ratio on Channel 4132 (826.4 MHz)**

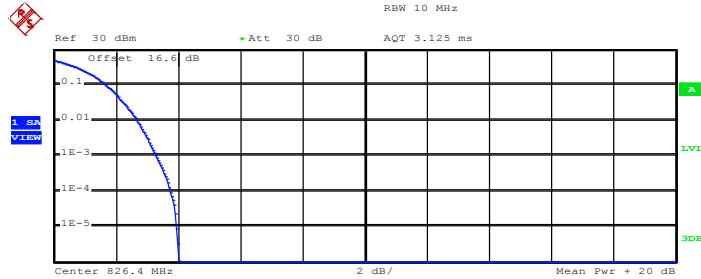

Complementary Cumulative Distribution Function (100000 samples)

Trace 1

Mean	19.15 dBm
Peak	23.17 dBm
Crest	4.02 dB
10 %	1.68 dB
1 %	2.68 dB
.1 %	3.28 dB
.01 %	3.76 dB

Date: 16.JUN.2015 14:16:17

**Peak-to-Average Ratio on Channel 4182 (836.4 MHz)**

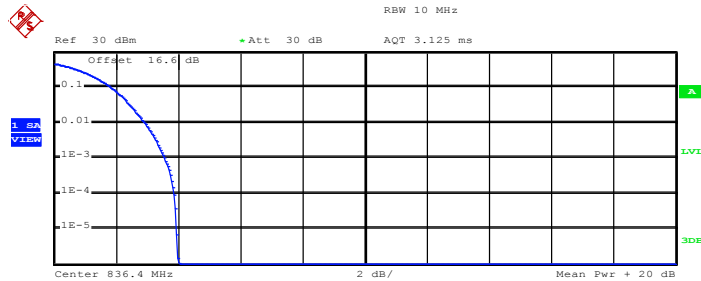

Complementary Cumulative Distribution Function (100000 samples)

Trace 1

Mean	20.01 dBm
Peak	24.01 dBm
Crest	4.00 dB
10 %	1.84 dB
1 %	2.92 dB
.1 %	3.56 dB
.01 %	3.88 dB

Date: 16.JUN.2015 14:16:25



Peak-to-Average Ratio on Channel 4233 (846.6 MHz)

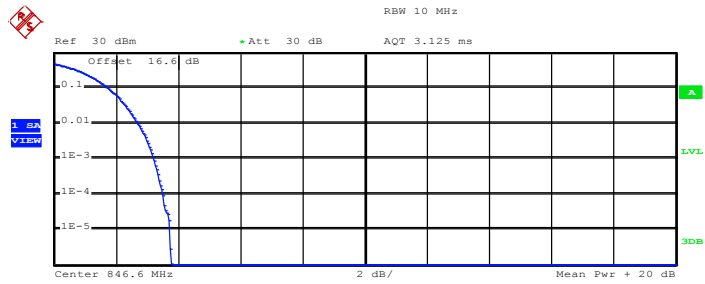

Complementary Cumulative Distribution Function (100000 samples)

Trace 1

Mean	19.97 dBm
Peak	23.73 dBm
Crest	3.76 dB
10 %	1.76 dB
1 %	2.72 dB
.1 %	3.24 dB
.01 %	3.52 dB

Date: 16.JUN.2015 14:16:32



<b>Band :</b>	WCDMA Band II	<b>Test Mode :</b>	RMC 12.2Kbps Link (QPSK)
---------------	---------------	--------------------	--------------------------

**Peak-to-Average Ratio on Channel 9262 (1852.4 MHz)**

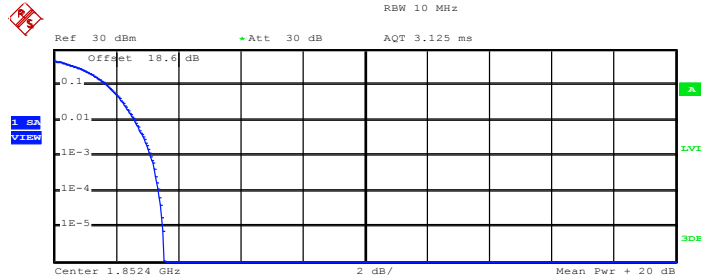

Complementary Cumulative Distribution Function (100000 samples)

Trace 1

Mean	21.18 dBm
Peak	24.72 dBm
Crest	3.54 dB
10 %	1.72 dB
1 %	2.60 dB
.1 %	3.12 dB
.01 %	3.36 dB

Date: 16.JUN.2015 14:48:49

**Peak-to-Average Ratio on Channel 9400 (1880.0 MHz)**

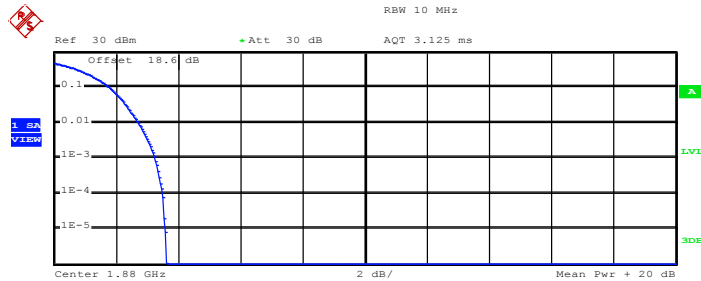

Complementary Cumulative Distribution Function (100000 samples)

Trace 1

Mean	21.80 dBm
Peak	25.42 dBm
Crest	3.62 dB
10 %	1.80 dB
1 %	2.72 dB
.1 %	3.28 dB
.01 %	3.52 dB

Date: 16.JUN.2015 14:48:58



Peak-to-Average Ratio on Channel 9538 (1907.6 MHz)

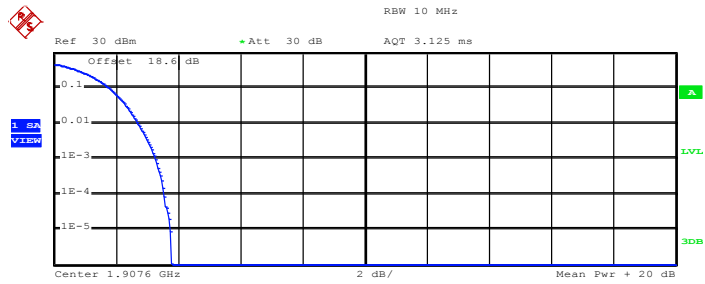

Complementary Cumulative Distribution Function (100000 samples)

Trace 1

Mean	21.50 dBm
Peak	25.28 dBm
Crest	3.78 dB
10 %	1.80 dB
1 %	2.72 dB
.1 %	3.28 dB
.01 %	3.56 dB

Date: 16.JUN.2015 14:49:05



<b>Band :</b>	CDMA2000 BC0	<b>Test Mode :</b>	1xRTT_RC1+SO55 (QPSK)
---------------	--------------	--------------------	-----------------------

Peak-to-Average Ratio on Channel 1013 (824.70 MHz)

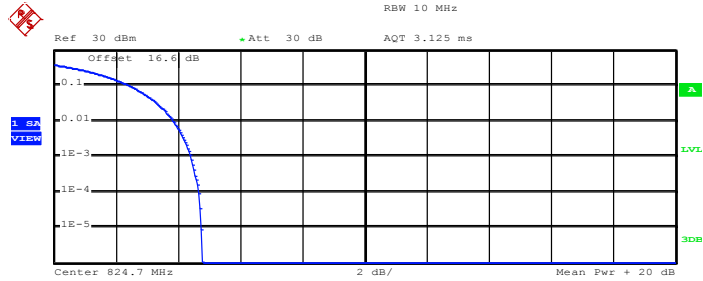

Complementary Cumulative Distribution Function (100000 samples)

Trace 1  
 Mean 23.27 dBm  
 Peak 28.03 dBm  
 Crest 4.76 dB

10 %	2.48 dB
1 %	3.88 dB
.1 %	4.40 dB
.01 %	4.68 dB

Date: 16.JUN.2015 18:00:20

Peak-to-Average Ratio on Channel 384 (836.52 MHz)

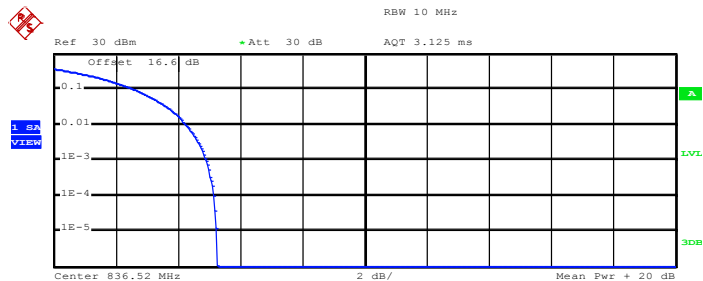

Complementary Cumulative Distribution Function (100000 samples)

Trace 1  
 Mean 23.42 dBm  
 Peak 28.67 dBm  
 Crest 5.25 dB

10 %	2.64 dB
1 %	4.28 dB
.1 %	4.92 dB
.01 %	5.16 dB

Date: 16.JUN.2015 18:00:29



Peak-to-Average Ratio on Channel 777 (848.31 MHz)

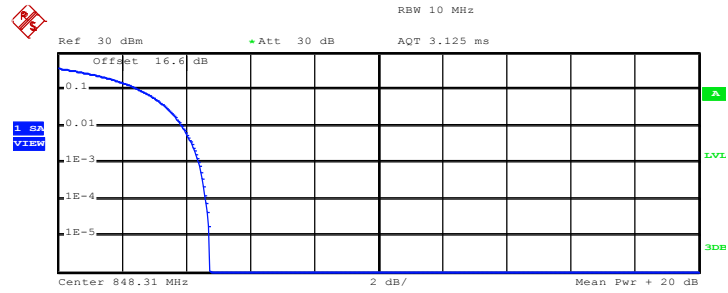

Complementary Cumulative Distribution Function (100000 samples)

Trace 1

Mean	23.37 dBm
Peak	28.10 dBm
Crest	4.74 dB
10 %	2.60 dB
1 %	3.88 dB
.1 %	4.40 dB
.01 %	4.64 dB

Date: 16.JUN.2015 18:00:45



<b>Band :</b>	CDMA2000 BC0	<b>Test Mode :</b>	1xEV-DO Rev. 0_RTAP 153.6K (QPSK)
---------------	--------------	--------------------	-----------------------------------

Peak-to-Average Ratio on Channel 1013 (824.70 MHz)

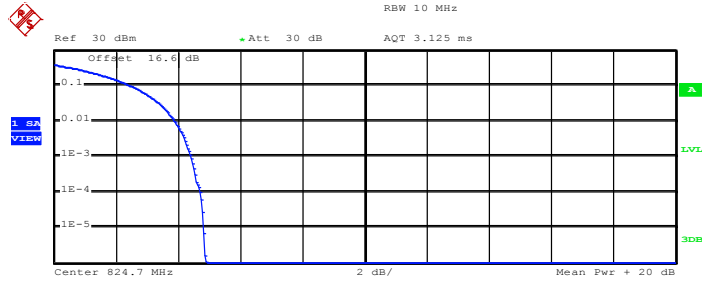

Complementary Cumulative Distribution Function (100000 samples)

Trace 1  
Mean 23.36 dBm  
Peak 28.24 dBm  
Crest 4.88 dB

10 %	2.52 dB
1 %	3.88 dB
.1 %	4.44 dB
.01 %	4.72 dB

Date: 16.JUN.2015 18:30:30

Peak-to-Average Ratio on Channel 384 (836.52 MHz)

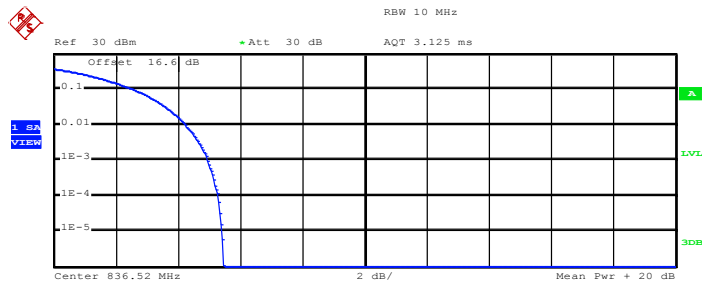

Complementary Cumulative Distribution Function (100000 samples)

Trace 1  
Mean 23.48 dBm  
Peak 28.95 dBm  
Crest 5.47 dB

10 %	2.64 dB
1 %	4.24 dB
.1 %	4.96 dB
.01 %	5.28 dB

Date: 16.JUN.2015 18:30:41



Peak-to-Average Ratio on Channel 777 (848.31 MHz)

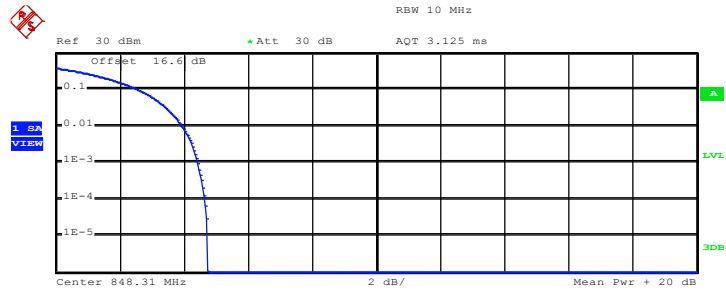

Complementary Cumulative Distribution Function (100000 samples)

Trace 1	
Mean	23.36 dBm
Peak	28.10 dBm
Crest	4.74 dB
10 %	2.64 dB
1 %	3.96 dB
.1 %	4.44 dB
.01 %	4.68 dB

Date: 16.JUN.2015 18:30:51



Band :	CDMA2000 BC1	Test Mode :	1xRTT_RC1+SO55 (QPSK)
--------	--------------	-------------	-----------------------

Peak-to-Average Ratio on Channel 25 (1851.25 MHz)

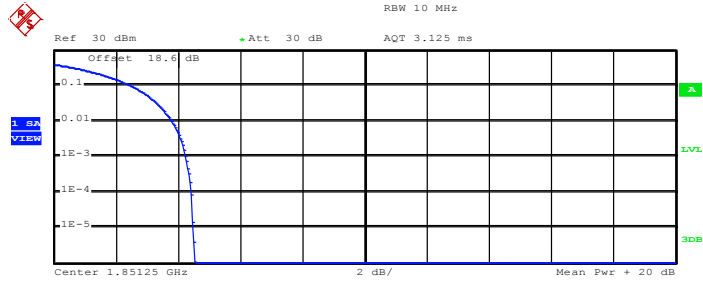

Complementary Cumulative Distribution Function (100000 samples)

Trace 1

Mean	22.66 dBm
Peak	27.19 dBm
Crest	4.53 dB
10 %	2.52 dB
1 %	3.80 dB
.1 %	4.24 dB
.01 %	4.44 dB

Date: 16.JUN.2015 18:46:22

Peak-to-Average Ratio on Channel 600 (1880 MHz)

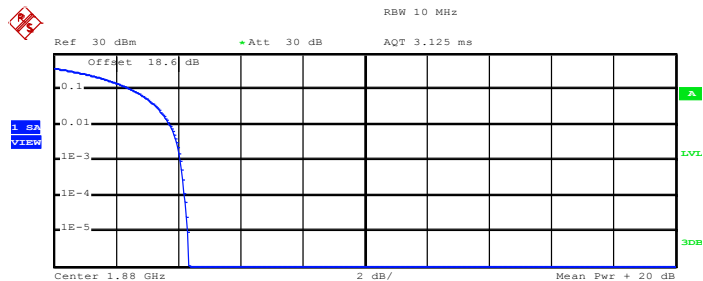

Complementary Cumulative Distribution Function (100000 samples)

Trace 1

Mean	23.20 dBm
Peak	27.54 dBm
Crest	4.34 dB
10 %	2.52 dB
1 %	3.76 dB
.1 %	4.08 dB
.01 %	4.20 dB

Date: 16.JUN.2015 18:46:32



Peak-to-Average Ratio on Channel 1175 (1908.75 MHz)

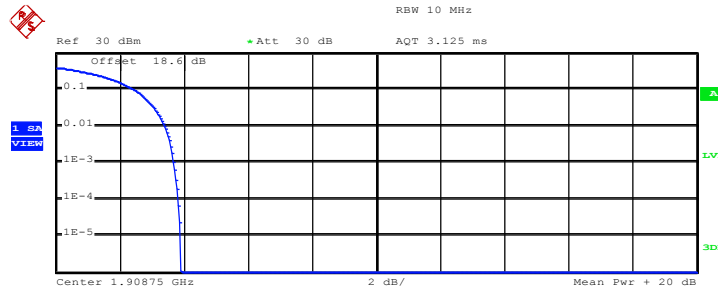

Complementary Cumulative Distribution Function (100000 samples)

Trace 1	
Mean	22.87 dBm
Peak	26.76 dBm
Crest	3.89 dB
10 %	2.48 dB
1 %	3.40 dB
.1 %	3.68 dB
.01 %	3.84 dB

Date: 16.JUN.2015 18:46:42



<b>Band :</b>	CDMA2000 BC1	<b>Test Mode :</b>	1xEV-DO Rev. 0_RTAP 153.6K (QPSK)
---------------	--------------	--------------------	-----------------------------------

Peak-to-Average Ratio on Channel 25 (1851.25 MHz)

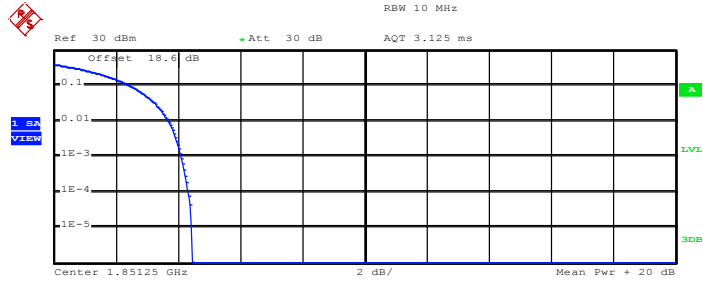

Complementary Cumulative Distribution Function (100000 samples)

Trace 1

Mean	23.02 dBm
Peak	27.47 dBm
Crest	4.44 dB
10 %	2.52 dB
1 %	3.68 dB
.1 %	4.12 dB
.01 %	4.32 dB

Date: 16.JUN.2015 19:04:09

Peak-to-Average Ratio on Channel 600 (1880 MHz)

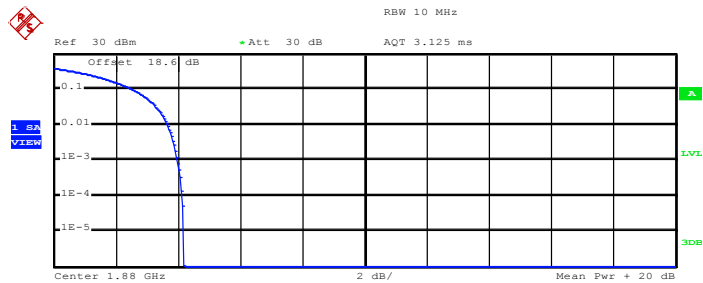

Complementary Cumulative Distribution Function (100000 samples)

Trace 1

Mean	23.57 dBm
Peak	27.75 dBm
Crest	4.18 dB
10 %	2.56 dB
1 %	3.68 dB
.1 %	4.00 dB
.01 %	4.16 dB

Date: 16.JUN.2015 19:04:19



Peak-to-Average Ratio on Channel 1175 (1908.75 MHz)

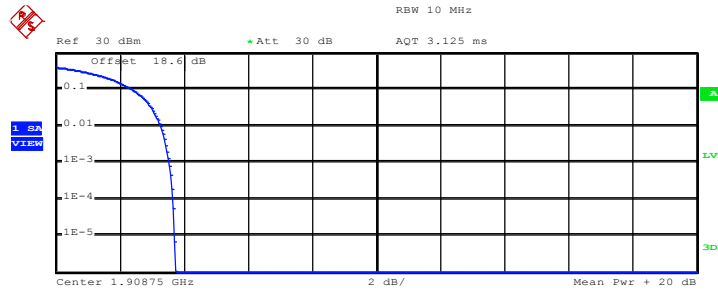

Complementary Cumulative Distribution Function (100000 samples)

Trace 1	
Mean	23.19 dBm
Peak	26.90 dBm
Crest	3.72 dB
10 %	2.40 dB
1 %	3.28 dB
.1 %	3.56 dB
.01 %	3.68 dB

Date: 16.JUN.2015 19:04:30



### 3.3 Effective Radiated Power and Effective Isotropic Radiated Power Measurement

#### 3.3.1 Description of the ERP/EIRP Measurement

The substitution method, in ANSI / TIA / EIA-603-C-2004, was used for ERP/EIRP measurement, and the spectrum analyzer configuration follows KDB 971168 D01 Power Meas. License Digital Systems v02r02. The ERP of mobile transmitters must not exceed 7 Watts and the EIRP of mobile transmitters are limited to 2 Watts.

#### 3.3.2 Measuring Instruments

The measuring equipment is listed in the section 4 of this test report.

#### 3.3.3 Test Procedures

1. The testing follows FCC KDB 971168 v02r02 Section 5.2.1. (for CDMA/WCDMA), Section 5.2.2.2 (for GSM/GPRS/EDGE) and ANSI / TIA-603-C-2004 Section 2.2.17.
2. The EUT was placed on a non-conductive rotating platform 0.8 meters high in a semi-anechoic chamber. The radiated emission at the fundamental frequency was measured at 3 m with a test antenna and a spectrum analyzer with RMS detector per section 5. of KDB 971168 D01.
3. During the measurement, the system simulator parameters were set to force the EUT transmitting at maximum output power. The maximum emission was recorded from analyzer power level (LVL) from the 360 degrees rotation of the turntable and the test antenna raised and lowered over a range from 1 to 4 meters in both horizontally and vertically polarized orientations.
4. Effective Isotropic Radiated Power (EIRP) was measured by substitution method according to TIA/EIA-603-C. The EUT was replaced by the substitution antenna at same location, and then a known power from S.G. was applied into the dipole antenna through a Tx cable, and then recorded the maximum Analyzer reading through raised and lowered the test antenna. The correction factor (in dB) = S.G. - Tx Cable loss + Substitution antenna gain - Analyzer reading. Then the EUT's EIRP was calculated with the correction factor,  $EIRP = LVL + \text{Correction factor}$  and  $ERP = EIRP - 2.15$ . Take the record of the output power at substitution antenna.

	GSM/GPRS/EDGE	CDMA2000/EV-DO	WCDMA/HSPA
SPAN	500kHz	3MHz	10MHz
RBW	10kHz	30kHz	100kHz
VBW	30kHz	100kHz	300kHz
Detector	RMS	RMS	RMS
Trace	Average	Average	Average
Average Type	Power	Power	Power
Sweep Count	100	100	100

**3.3.4 Test Setup**

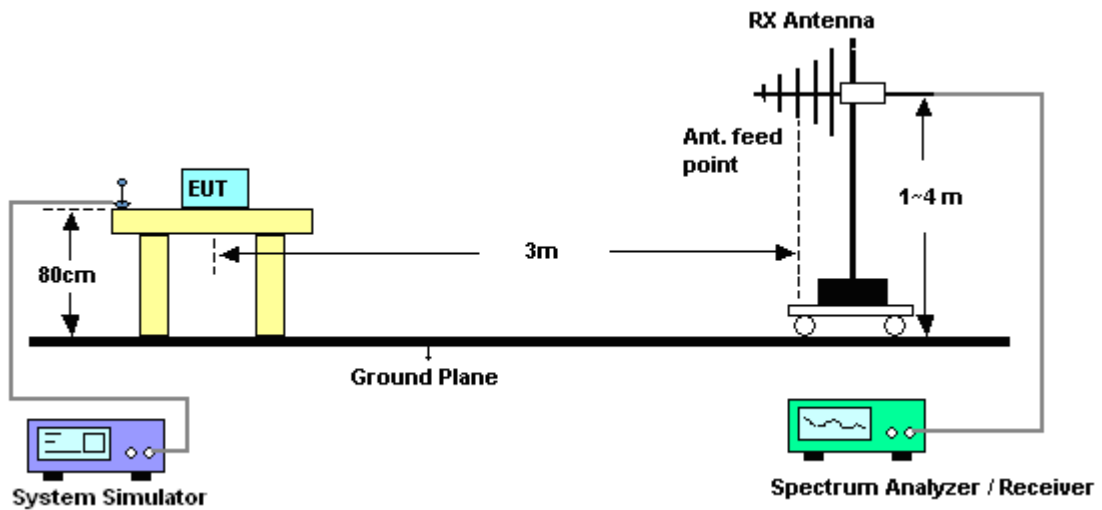



3.3.5 Test Result of ERP

GSM850 (GPRS class 8) Radiated Power ERP					
Channel	Frequency (MHz)	Horizontal		Vertical	
		ERP(dBm)	ERP(W)	ERP(dBm)	ERP(W)
Lowest	824.2	21.68	0.1472	28.19	0.6592
Middle	836.4	22.01	0.1589	28.13	0.6501
Highest	848.8	22.52	0.1786	28.20	0.6607
Limit	ERP < 7W	Result		PASS	

GSM850 (EDGE class 8) Radiated Power ERP					
Channel	Frequency (MHz)	Horizontal		Vertical	
		ERP(dBm)	ERP(W)	ERP(dBm)	ERP(W)
Lowest	824.2	15.57	0.0361	22.03	0.1596
Middle	836.4	15.65	0.0367	22.07	0.1611
Highest	848.8	16.23	0.0420	21.96	0.1570
Limit	ERP < 7W	Result		PASS	

WCDMA Band V (RMC 12.2Kbps) Radiated Power ERP					
Channel	Frequency (MHz)	Horizontal		Vertical	
		ERP(dBm)	ERP(W)	ERP(dBm)	ERP(W)
Lowest	826.4	13.11	0.0205	19.11	0.0815
Middle	836.4	13.48	0.0223	19.24	0.0839
Highest	846.6	12.81	0.0191	18.26	0.0670
Limit	ERP < 7W	Result		PASS	

CDMA2000 BC0 1xRTT_RC1+SO55 Radiated Power ERP					
Channel	Frequency (MHz)	Horizontal		Vertical	
		ERP(dBm)	ERP(W)	ERP(dBm)	ERP(W)
Lowest	824.70	13.95	0.0248	22.24	0.1675
Middle	836.52	14.34	0.0272	22.35	0.1718
Highest	848.31	14.70	0.0295	22.45	0.1758
Limit	ERP < 7W	Result		PASS	



CDMA2000 BC0 1xEV-DO Rev. 0_RTAP 153.6K Radiated Power ERP					
Channel	Frequency (MHz)	Horizontal		Vertical	
		ERP(dBm)	ERP(W)	ERP(dBm)	ERP(W)
Lowest	824.70	12.89	0.0195	21.22	0.1324
Middle	836.52	13.39	0.0218	21.42	0.1387
Highest	848.31	13.86	0.0243	21.17	0.1309
Limit	ERP < 7W	Result		PASS	



3.3.6 Test Result of EIRP

GSM1900 (GPRS class 8) Radiated Power EIRP					
Channel	Frequency (MHz)	Horizontal		Vertical	
		EIRP(dBm)	EIRP(W)	EIRP(dBm)	EIRP(W)
Lowest	1850.2	25.32	0.3404	30.66	1.1641
Middle	1880.0	25.90	0.3890	31.86	1.5346
Highest	1909.8	25.58	0.3614	31.71	1.4825
Limit	EIRP < 2W	Result		PASS	

GSM1900 (EDGE class 8) Radiated Power EIRP					
Channel	Frequency (MHz)	Horizontal		Vertical	
		EIRP(dBm)	EIRP(W)	EIRP(dBm)	EIRP(W)
Lowest	1850.2	21.25	0.1334	26.48	0.4446
Middle	1880.0	21.28	0.1343	27.62	0.5781
Highest	1909.8	21.98	0.1578	28.86	0.7691
Limit	EIRP < 2W	Result		PASS	

WCDMA Band II (RMC 12.2Kbps) Radiated Power EIRP					
Channel	Frequency (MHz)	Horizontal		Vertical	
		EIRP(dBm)	EIRP(W)	EIRP(dBm)	EIRP(W)
Lowest	1852.4	18.70	0.0741	23.98	0.2500
Middle	1880.0	17.97	0.0627	25.54	0.3581
Highest	1907.6	20.00	0.1000	25.97	0.3954
Limit	EIRP < 2W	Result		PASS	

CDMA2000 BC1 1xRTT_RC1+SO55 Radiated Power EIRP					
Channel	Frequency (MHz)	Horizontal		Vertical	
		EIRP(dBm)	EIRP(W)	EIRP(dBm)	EIRP(W)
Lowest	1851.25	19.10	0.0813	24.40	0.2754
Middle	1880.00	19.43	0.0877	25.28	0.3373
Highest	1908.75	19.73	0.0940	25.94	0.3926
Limit	EIRP < 2W	Result		PASS	



CDMA2000 BC1 1xEV-DO Rev. 0_RTAP 153.6K Radiated Power EIRP					
Channel	Frequency (MHz)	Horizontal		Vertical	
		EIRP(dBm)	EIRP(W)	EIRP(dBm)	EIRP(W)
Lowest	1851.25	19.14	0.0820	24.41	0.2761
Middle	1880.00	19.36	0.0863	25.37	0.3443
Highest	1908.75	19.85	0.0966	26.03	0.4009
Limit	EIRP < 2W	Result		PASS	

## 3.4 99% Occupied Bandwidth and 26dB Bandwidth Measurement

### 3.4.1 Description of 99% Occupied Bandwidth and 26dB Bandwidth Measurement

The 99% occupied bandwidth is the width of a frequency band such that, below the lower and above the upper frequency limits, the mean powers emitted are each equal to a specified percentage 0.5% of the total mean transmitted power.

The emission bandwidth is defined as the width of the signal between two points, located at the 2 sides of the carrier frequency, outside of which all emissions are attenuated at least 26 dB below the transmitter power.

### 3.4.2 Measuring Instruments

The measuring equipment is listed in the section 4 of this test report.

### 3.4.3 Test Procedures

1. The testing follows FCC KDB 971168 v02r02 Section 4.2.
2. The EUT was connected to the spectrum analyzer and system simulator via a power divider.
3. The RF output of the EUT was connected to the spectrum analyzer by RF cable and attenuator. The path loss was compensated to the results for each measurement.
4. The 99% occupied bandwidth were measured, set RBW= 1% of span, VBW= 3\*RBW, sample detector, trace maximum hold.
5. The 26dB bandwidth were measured, set RBW= 1% of EBW, VBW= 3\*RBW, peak detector, trace maximum hold.

### 3.4.4 Test Setup

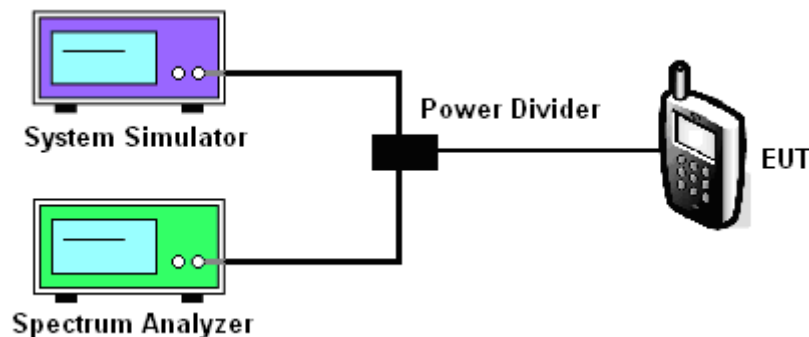



3.4.5 Test Result of Occupied Bandwidth and 26dB Bandwidth

Cellular Band						
Modes	GSM850 (GPRS class 8)			GSM850 (EDGE class 8)		
Channel	128 (Low)	189 (Mid)	251 (High)	128 (Low)	189 (Mid)	251 (High)
Frequency (MHz)	824.2	836.4	848.8	824.2	836.4	848.8
99% OBW (kHz)	244.00	237.00	247.00	239.00	234.00	241.00
26dB BW (kHz)	310.00	318.00	312.00	286.00	295.00	298.00

PCS Band						
Modes	GSM1900 (GPRS class 8)			GSM1900 (EDGE class 8)		
Channel	512 (Low)	661 (Mid)	810 (High)	512 (Low)	661 (Mid)	810 (High)
Frequency (MHz)	1850.2	1880	1909.8	1850.2	1880	1909.8
99% OBW (kHz)	246.00	243.00	244.00	243.00	244.00	244.00
26dB BW (kHz)	318.00	309.00	307.00	295.00	309.00	295.00

Cellular Band			
Modes	WCDMA Band V (RMC 12.2Kbps)		
Channel	4132 (Low)	4182 (Mid)	4233 (High)
Frequency (MHz)	826.4	836.4	846.6
99% OBW (MHz)	4.12	4.15	4.15
26dB BW (MHz)	4.71	4.71	4.69

PCS Band			
Modes	WCDMA Band II (RMC 12.2Kbps)		
Channel	9262 (Low)	9400 (Mid)	9538 (High)
Frequency (MHz)	1852.4	1880	1907.6
99% OBW (MHz)	4.16	4.15	4.15
26dB BW (MHz)	4.73	4.72	4.72



CDMA2000 BC0			
Test Mode	CDMA 2000 1xRTT		
Test Status	RC1+SO55		
Channel	1013 (Low)	384 (Mid)	777 (High)
Frequency (MHz)	824.70	836.52	848.31
99% OBW (MHz)	1.27	1.28	1.28
26dB BW (MHz)	1.41	1.40	1.41

CDMA2000 BC0			
Test Mode	CDMA 2000 1xEV-DO Rev. 0		
Test Status	RTAP 153.6K		
Channel	1013 (Low)	384 (Mid)	777 (High)
Frequency (MHz)	824.70	836.52	848.31
99% OBW (MHz)	1.28	1.28	1.28
26dB BW (MHz)	1.42	1.40	1.41

CDMA2000 BC1			
Test Mode	CDMA 2000 1xRTT		
Test Status	RC1+SO55		
Channel	25 (Low)	600 (Mid)	1175 (High)
Frequency (MHz)	1851.25	1880.00	1908.75
99% OBW (MHz)	1.28	1.28	1.28
26dB BW (MHz)	1.42	1.42	1.42

CDMA2000 BC1			
Test Mode	CDMA 2000 1xEV-DO Rev. 0		
Test Status	RTAP 153.6K		
Channel	25 (Low)	600 (Mid)	1175 (High)
Frequency (MHz)	1851.25	1880.00	1908.75
99% OBW (MHz)	1.28	1.28	1.28
26dB BW (MHz)	1.42	1.42	1.42



### 3.4.6 Test Result (Plots) of Occupied Bandwidth and 26dB Bandwidth

Band :	GSM 850	Test Mode :	GPRS class 8 Link (GMSK)
--------	---------	-------------	--------------------------

#### 99% Occupied Bandwidth Plot on Channel 128 (824.2 MHz)

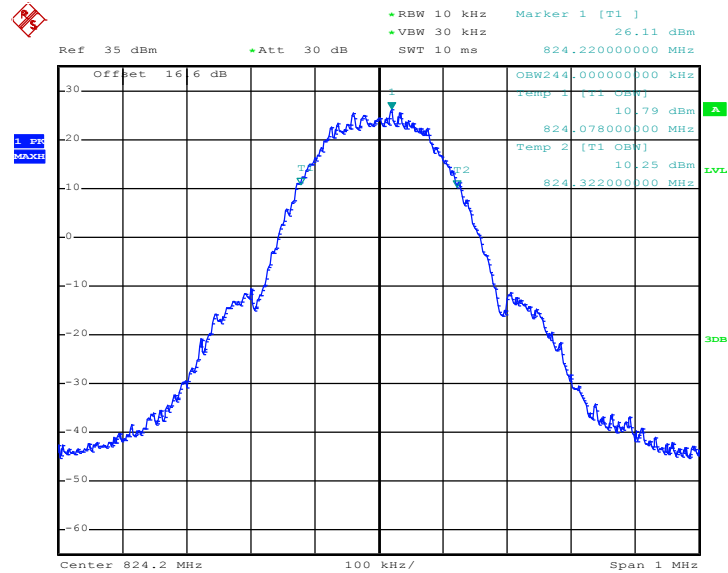

Date: 16.JUN.2015 13:44:07

#### 26dB Bandwidth Plot on Channel 128 (824.2 MHz)

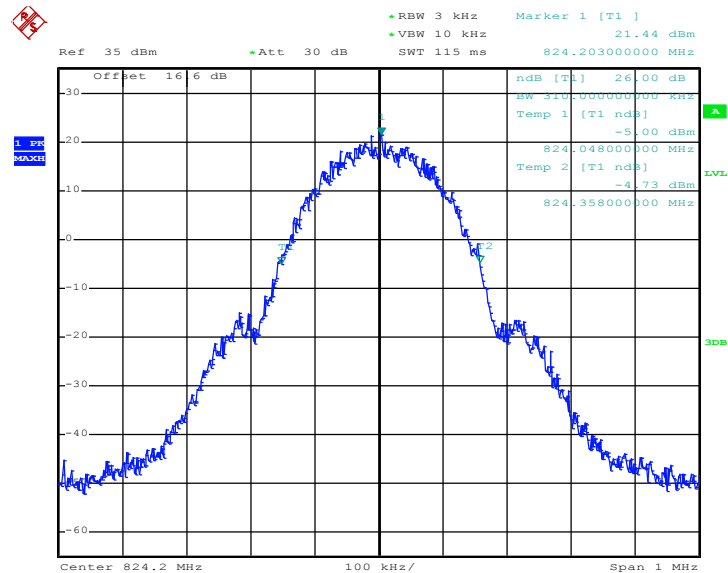

Date: 16.JUN.2015 13:42:30



99% Occupied Bandwidth Plot on Channel 189 (836.4 MHz)

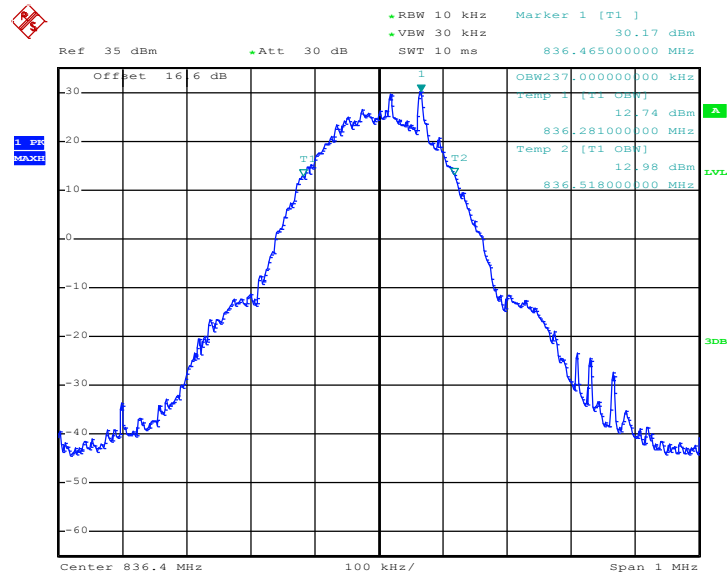

Date: 16.JUN.2015 13:44:35

26dB Bandwidth Plot on Channel 189 (836.4 MHz)

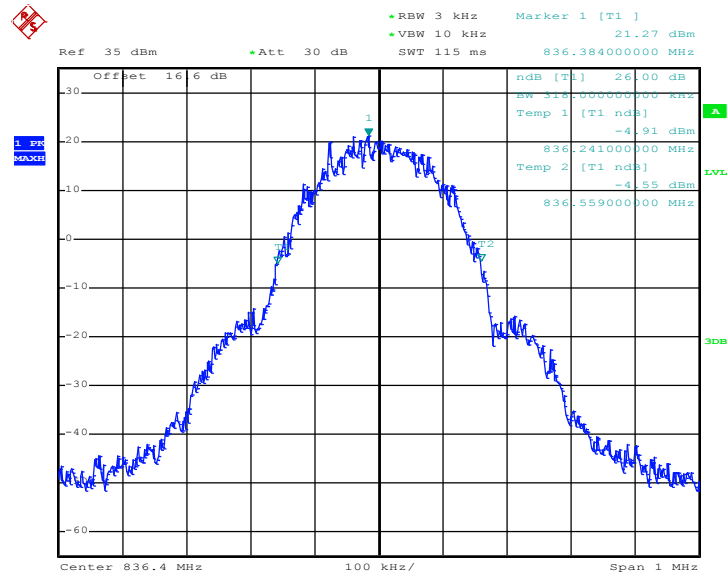

Date: 16.JUN.2015 13:42:59



99% Occupied Bandwidth Plot on Channel 251 (848.8 MHz)

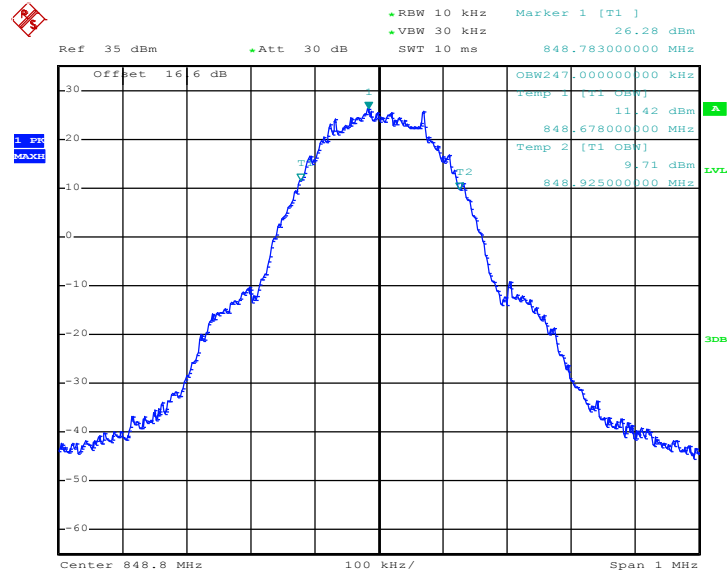

Date: 16.JUN.2015 13:45:04

26dB Bandwidth Plot on Channel 251 (848.8 MHz)

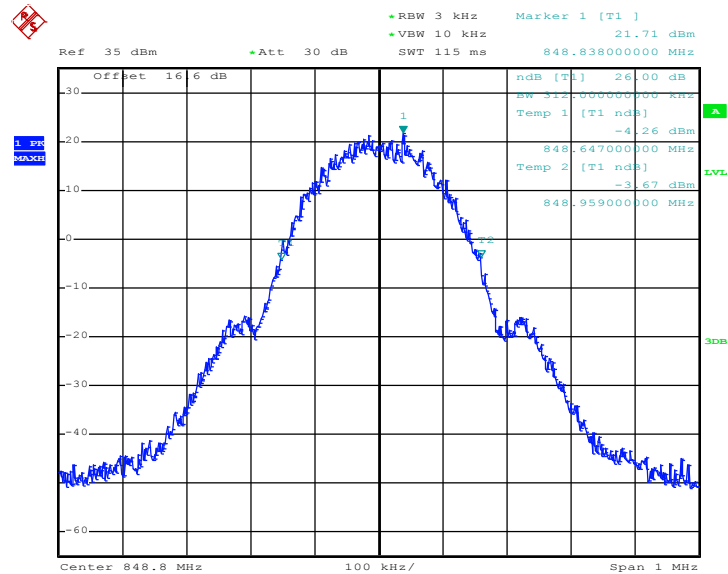

Date: 16.JUN.2015 13:43:27



<b>Band :</b>	GSM 850	<b>Test Mode :</b>	EDGE class 8 Link (8PSK)
---------------	---------	--------------------	--------------------------

99% Occupied Bandwidth Plot on Channel 128 (824.2 MHz)

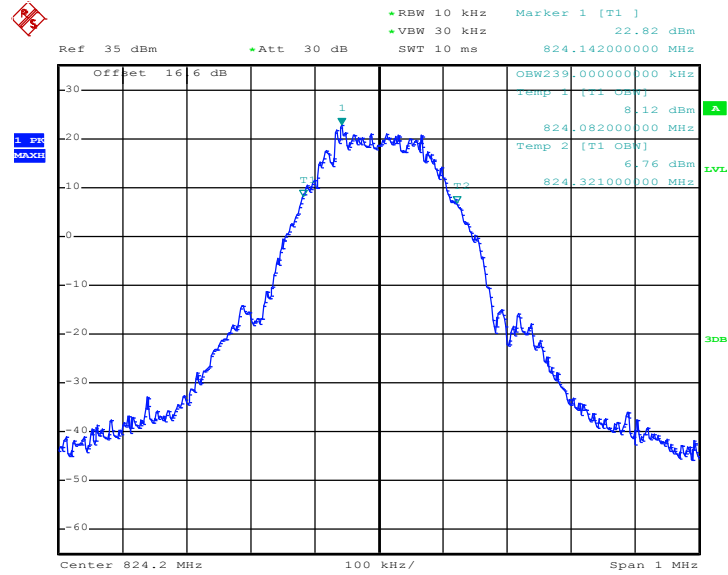

Date: 16.JUN.2015 13:59:35

26dB Bandwidth Plot on Channel 128 (824.2 MHz)

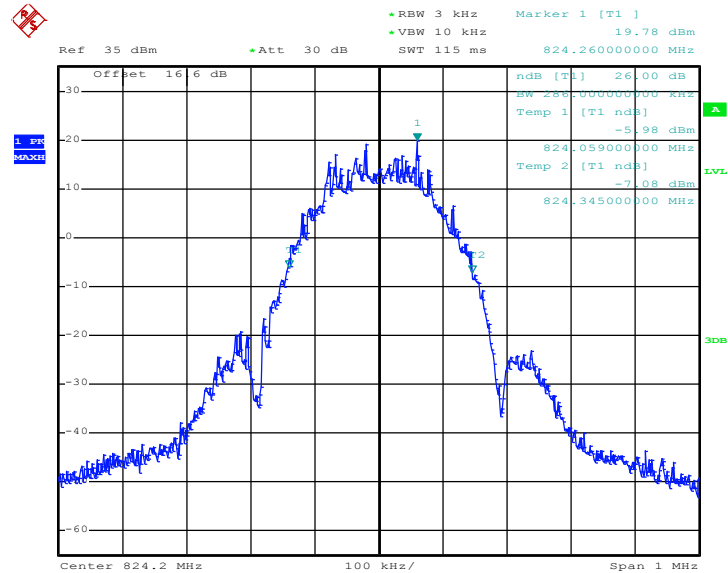

Date: 16.JUN.2015 13:57:27



99% Occupied Bandwidth Plot on Channel 189 (836.4 MHz)

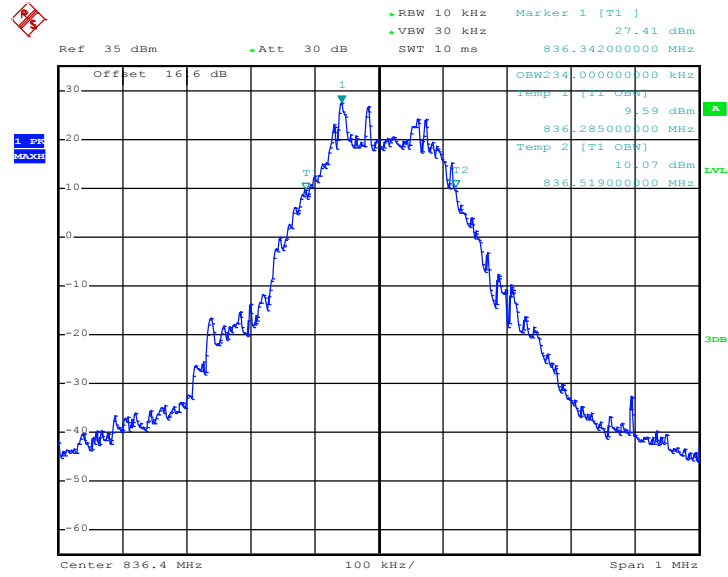

Date: 16.JUN.2015 14:00:03

26dB Bandwidth Plot on Channel 189 (836.4 MHz)

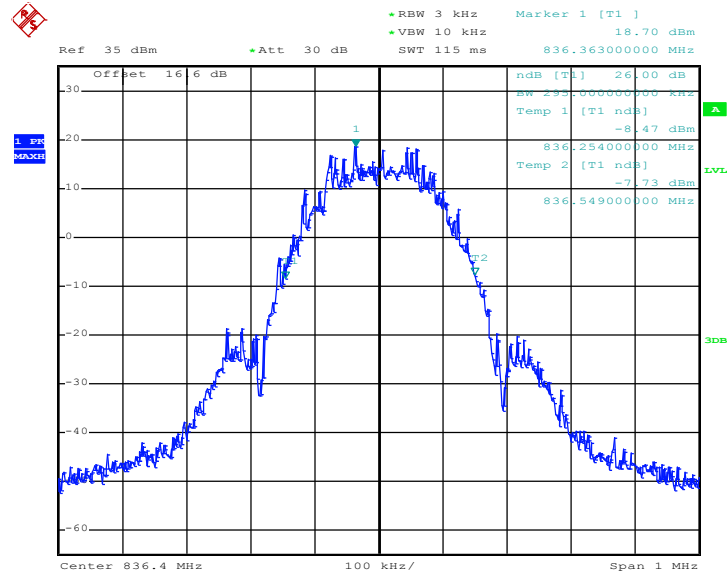

Date: 16.JUN.2015 13:57:56



99% Occupied Bandwidth Plot on Channel 251 (848.8 MHz)

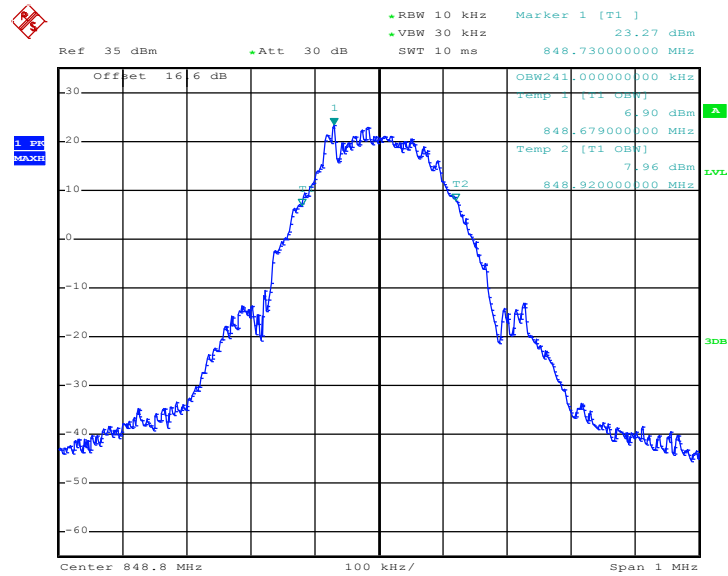

Date: 16.JUN.2015 14:00:32

26dB Bandwidth Plot on Channel 251 (848.8 MHz)

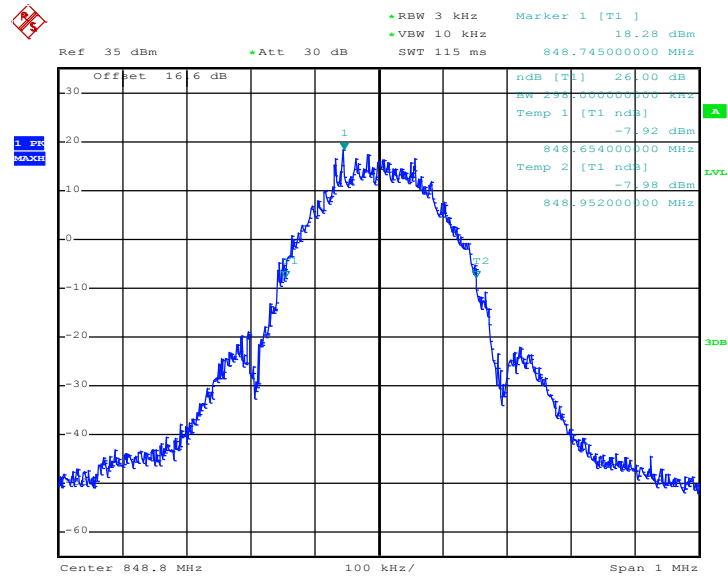

Date: 16.JUN.2015 13:58:24



<b>Band :</b>	GSM 1900	<b>Test Mode :</b>	GPRS class 8 Link (GMSK)
---------------	----------	--------------------	--------------------------

99% Occupied Bandwidth Plot on Channel 512 (1850.2 MHz)

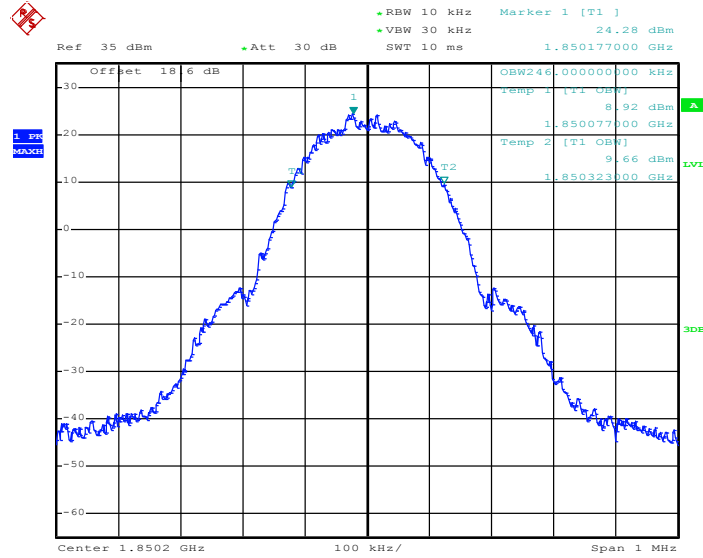

Date: 16.JUN.2015 14:21:42

26dB Bandwidth Plot on Channel 512 (1850.2 MHz)

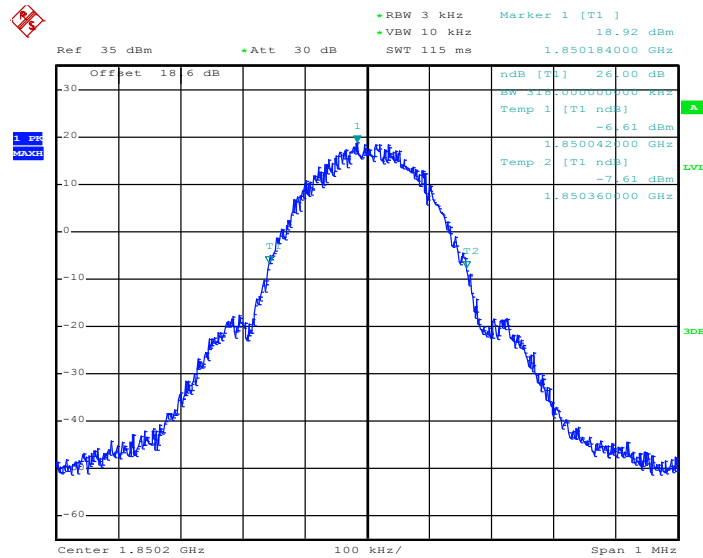

Date: 16.JUN.2015 14:19:49



### 99% Occupied Bandwidth Plot on Channel 661 (1880.0 MHz)

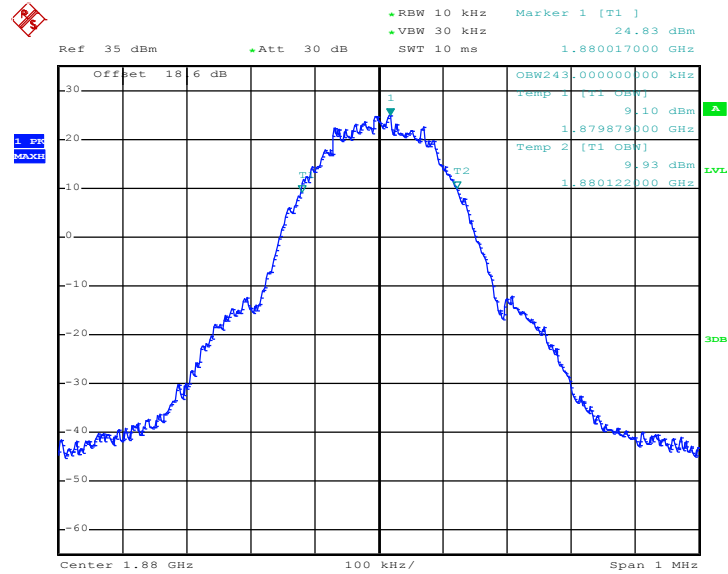

Date: 16.JUN.2015 14:22:10

### 26dB Bandwidth Plot on Channel 661 (1880.0 MHz)

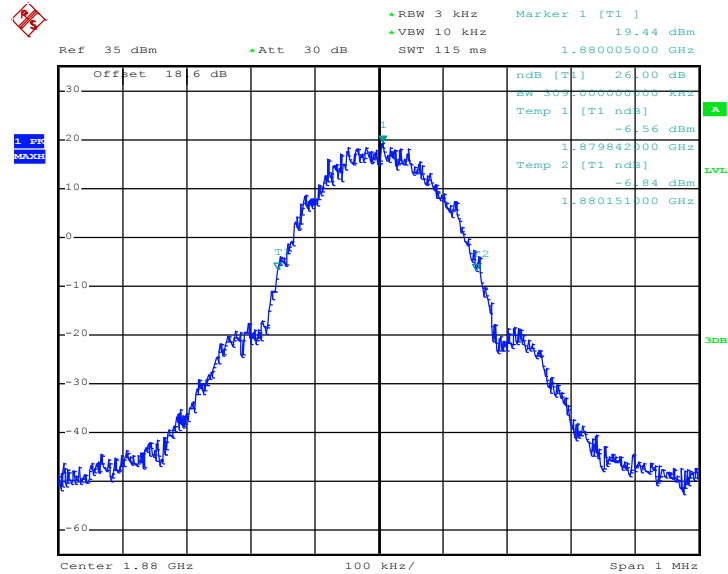

Date: 16.JUN.2015 14:20:18



99% Occupied Bandwidth Plot on Channel 810 (1909.8 MHz)

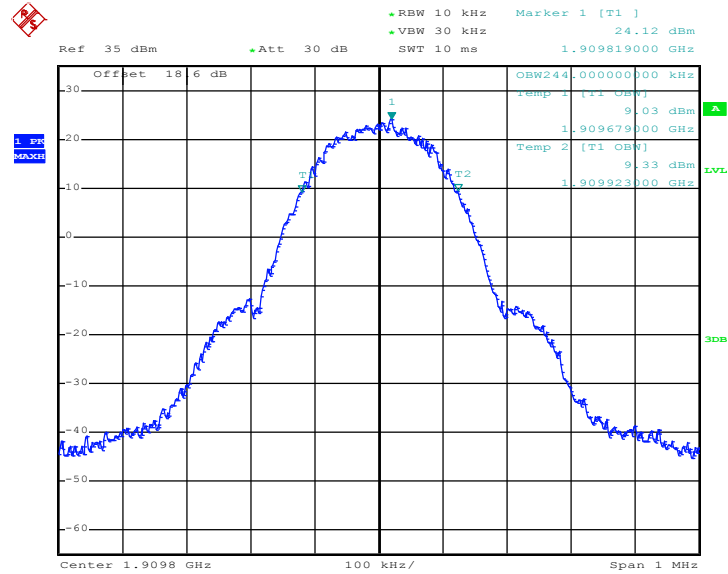

Date: 16.JUN.2015 14:22:38

26dB Bandwidth Plot on Channel 810 (1909.8 MHz)

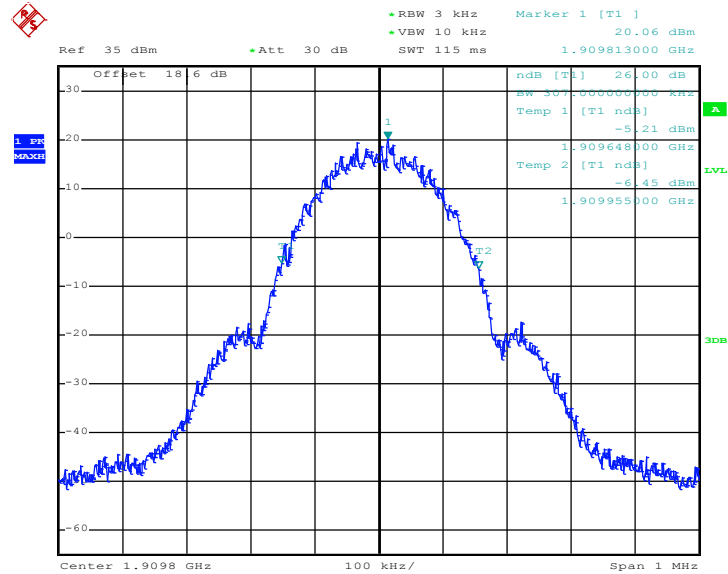

Date: 16.JUN.2015 14:20:46



<b>Band :</b>	GSM 1900	<b>Test Mode :</b>	EDGE class 8 Link (8PSK)
---------------	----------	--------------------	--------------------------

99% Occupied Bandwidth Plot on Channel 512 (1850.2 MHz)

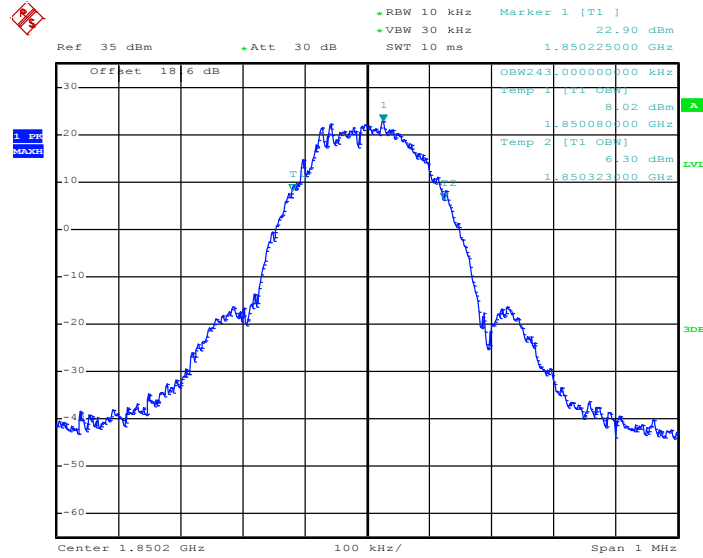

Date: 16.JUN.2015 14:31:32

26dB Bandwidth Plot on Channel 512 (1850.2 MHz)

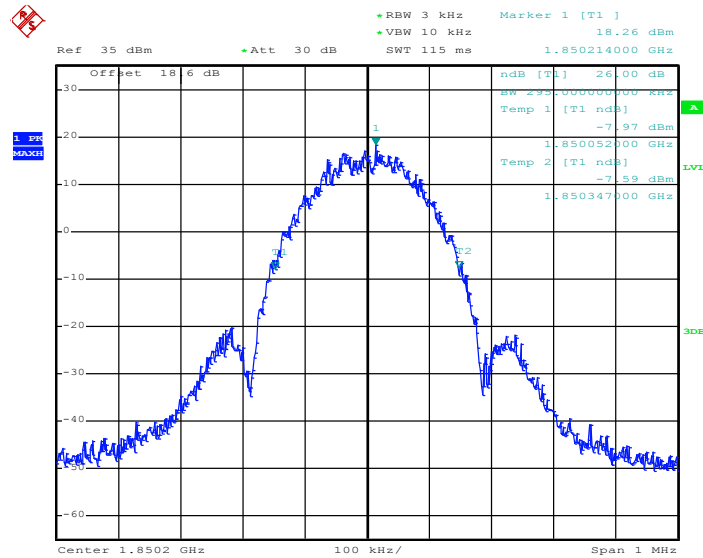

Date: 16.JUN.2015 14:30:02



99% Occupied Bandwidth Plot on Channel 661 (1880.0 MHz)

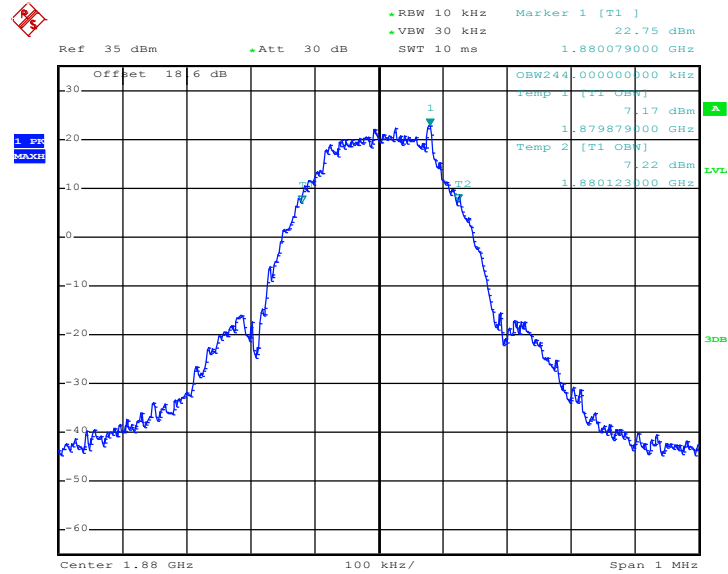

Date: 16.JUN.2015 14:32:01

26dB Bandwidth Plot on Channel 661 (1880.0 MHz)

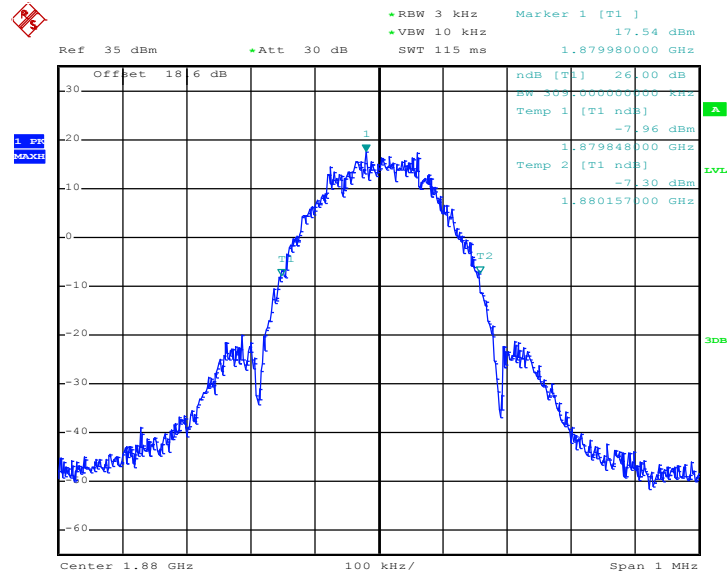

Date: 16.JUN.2015 14:30:30



### 99% Occupied Bandwidth Plot on Channel 810 (1909.8 MHz)

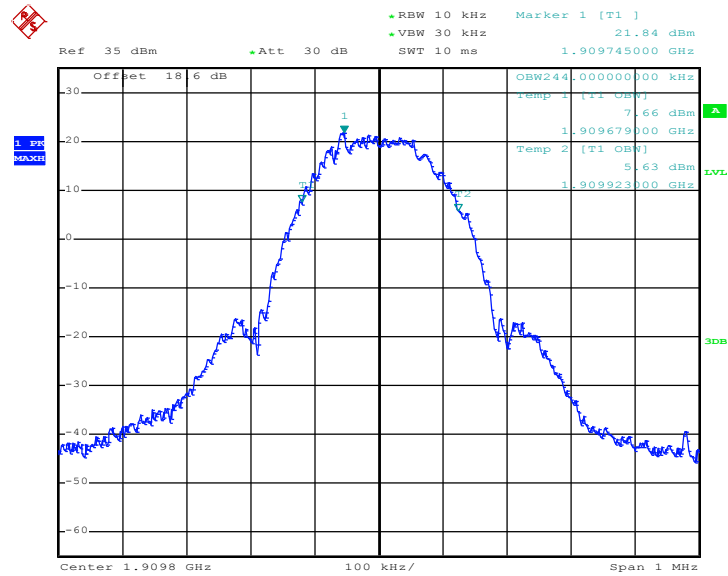

Date: 16.JUN.2015 14:32:29

### 26dB Bandwidth Plot on Channel 810 (1909.8 MHz)

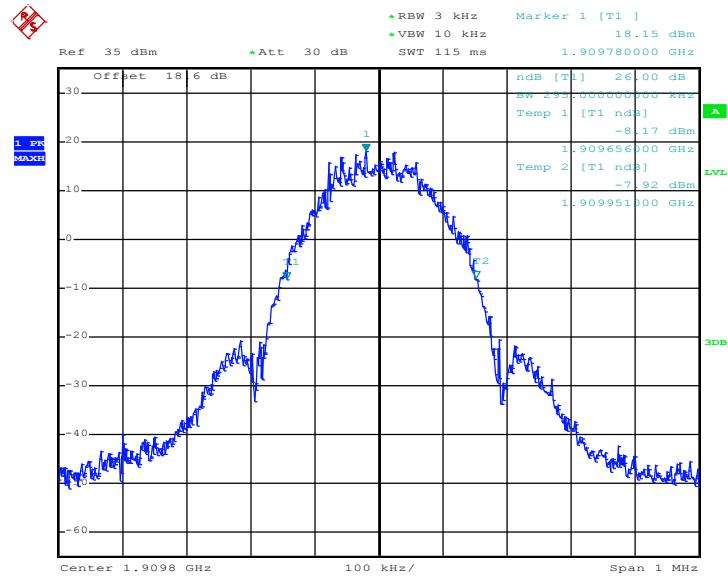

Date: 16.JUN.2015 14:30:59



<b>Band :</b>	WCDMA Band V	<b>Test Mode :</b>	RMC 12.2Kbps Link (QPSK)
---------------	--------------	--------------------	--------------------------

99% Occupied Bandwidth Plot on Channel 4132 (826.4 MHz)

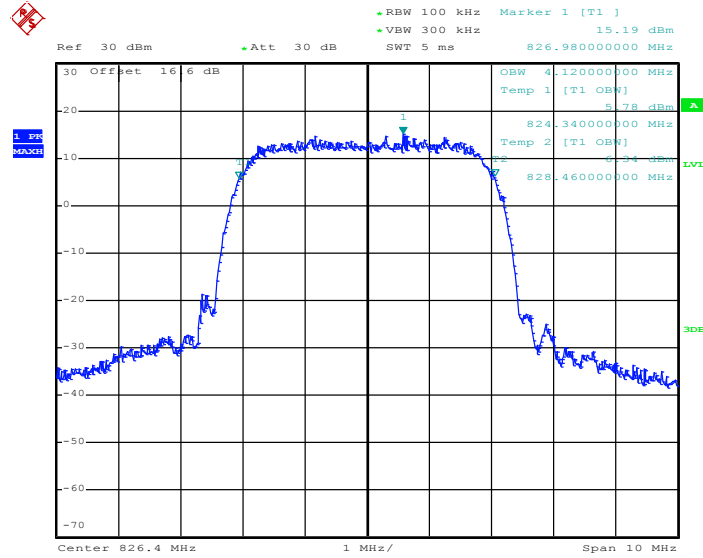

Date: 16.JUN.2015 14:10:26

26dB Bandwidth Plot on Channel 4132 (826.4 MHz)

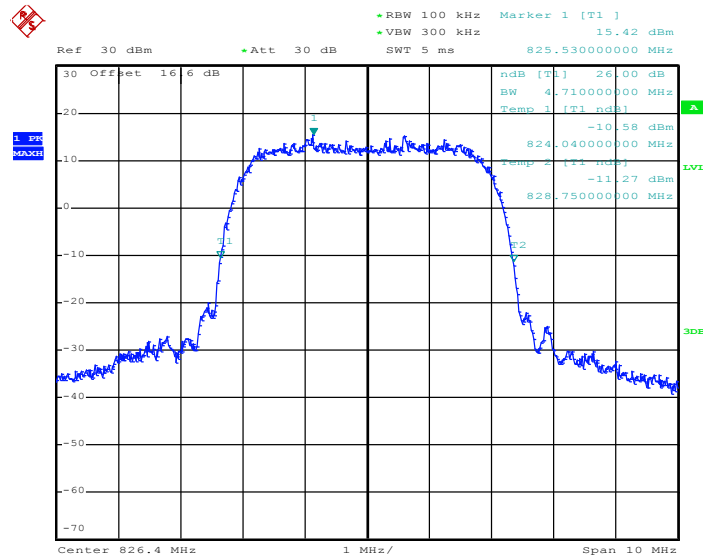

Date: 16.JUN.2015 14:08:39



99% Occupied Bandwidth Plot on Channel 4182 (836.4 MHz)

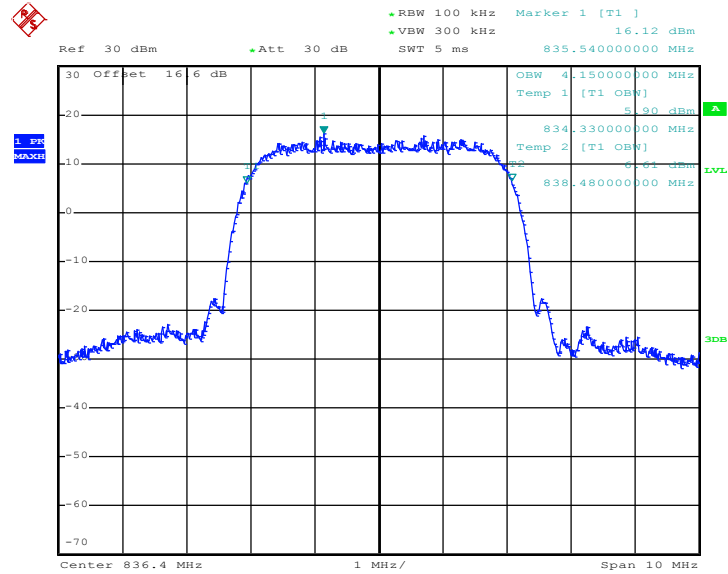

Date: 16.JUN.2015 14:10:54

26dB Bandwidth Plot on Channel 4182 (836.4 MHz)

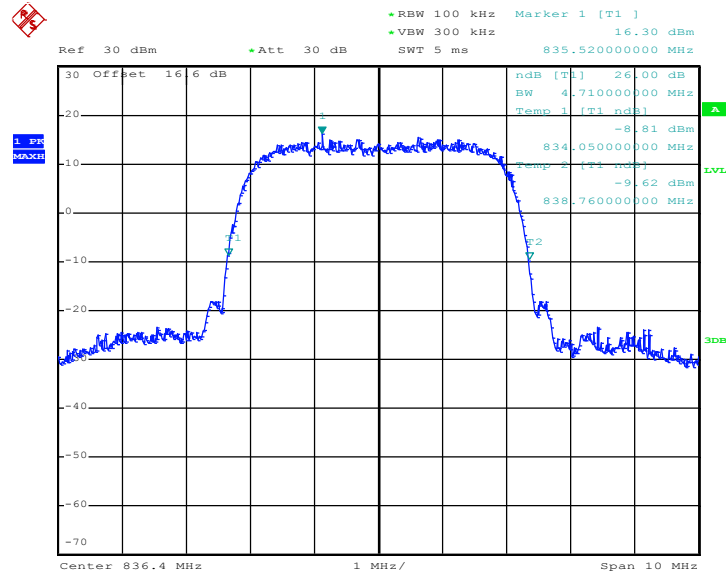

Date: 16.JUN.2015 14:09:07



99% Occupied Bandwidth Plot on Channel 4233 (846.6 MHz)

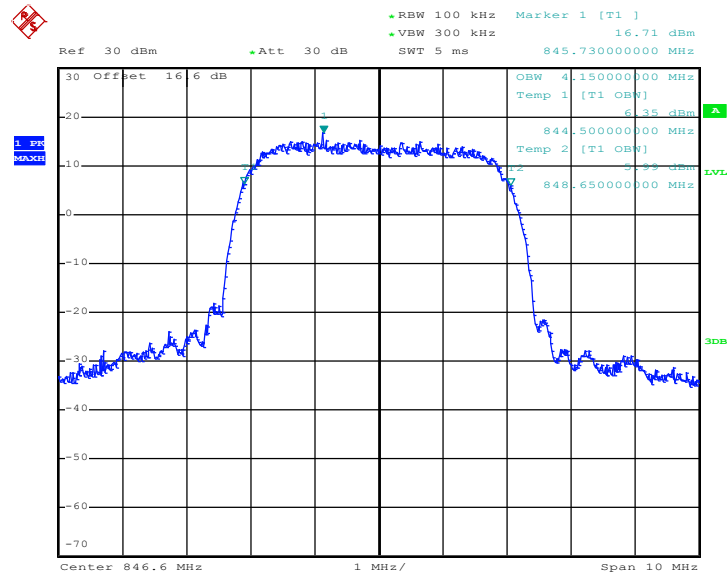

Date: 16.JUN.2015 14:11:22

26dB Bandwidth Plot on Channel 4233 (846.6 MHz)

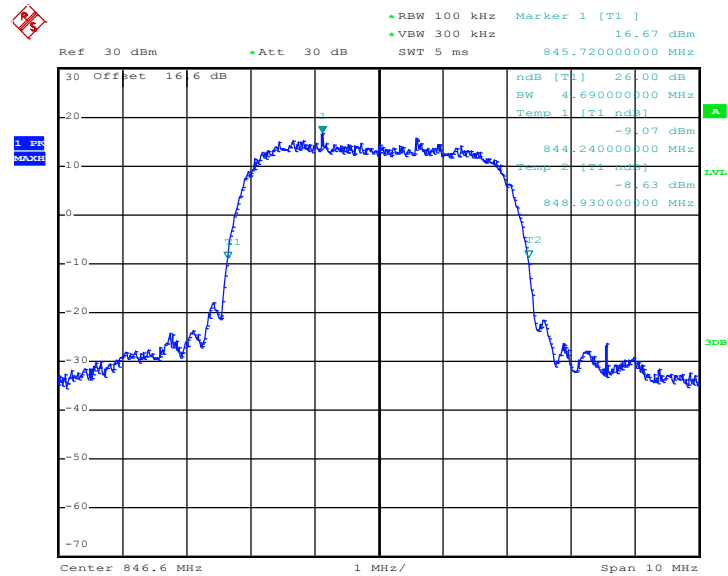

Date: 16.JUN.2015 14:09:35



<b>Band :</b>	WCDMA Band II	<b>Test Mode :</b>	RMC 12.2Kbps Link (QPSK)
---------------	---------------	--------------------	--------------------------

99% Occupied Bandwidth Plot on Channel 9262 (1852.4 MHz)

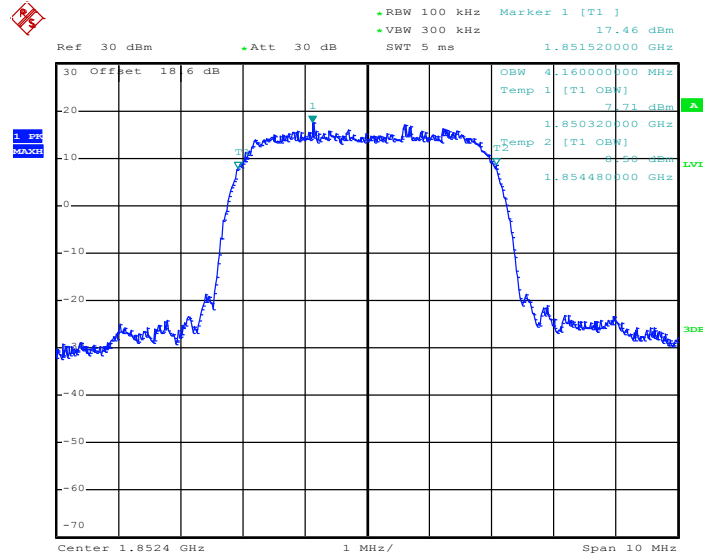

Date: 16.JUN.2015 14:43:05

26dB Bandwidth Plot on Channel 9262 (1852.4 MHz)

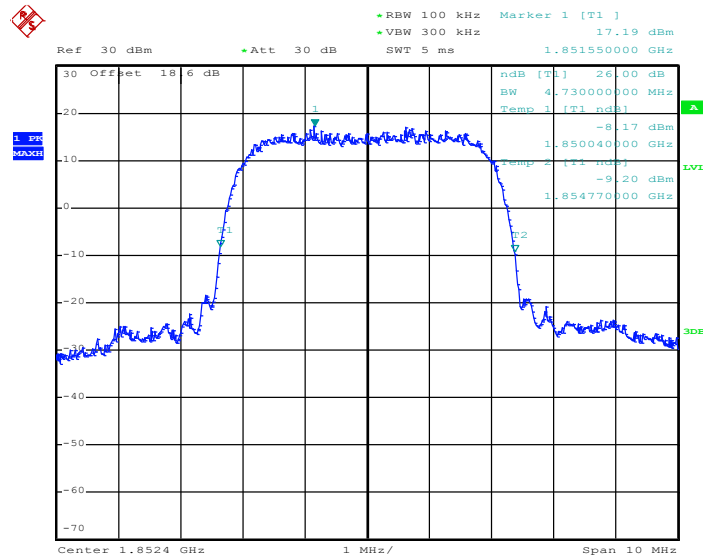

Date: 16.JUN.2015 14:41:34



99% Occupied Bandwidth Plot on Channel 9400 (1880.0 MHz)

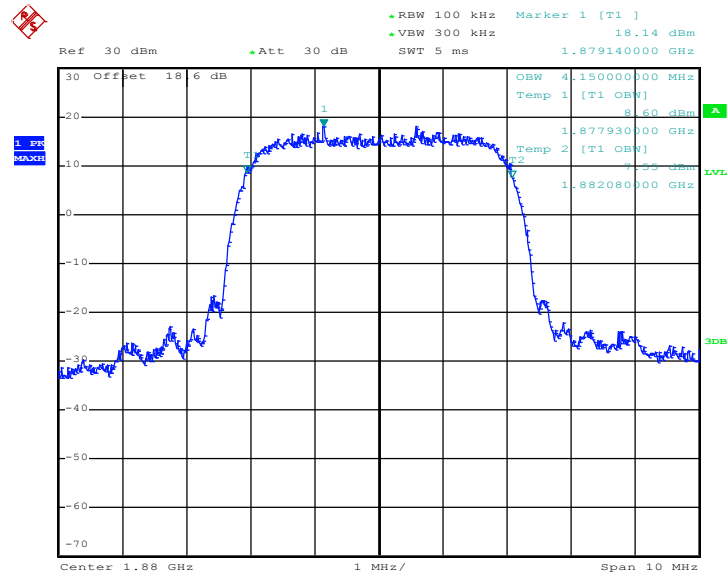

Date: 16.JUN.2015 14:43:34

26dB Bandwidth Plot on Channel 9400 (1880.0 MHz)

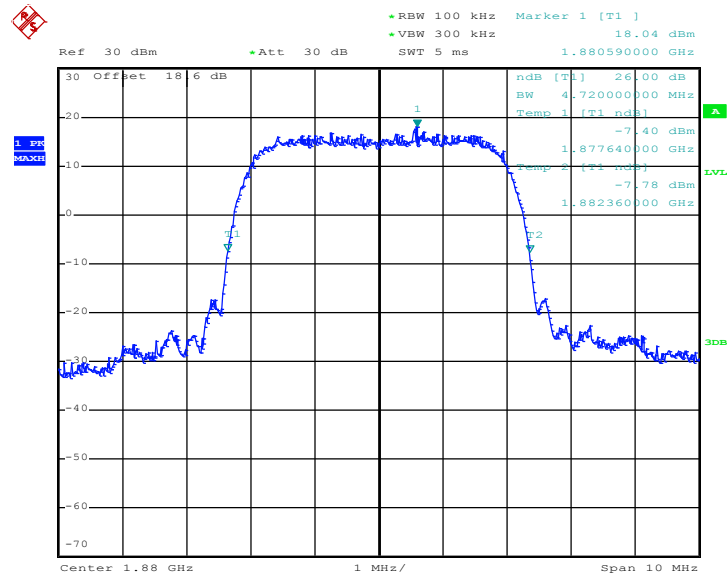

Date: 16.JUN.2015 14:42:02



### 99% Occupied Bandwidth Plot on Channel 9538 (1907.6 MHz)

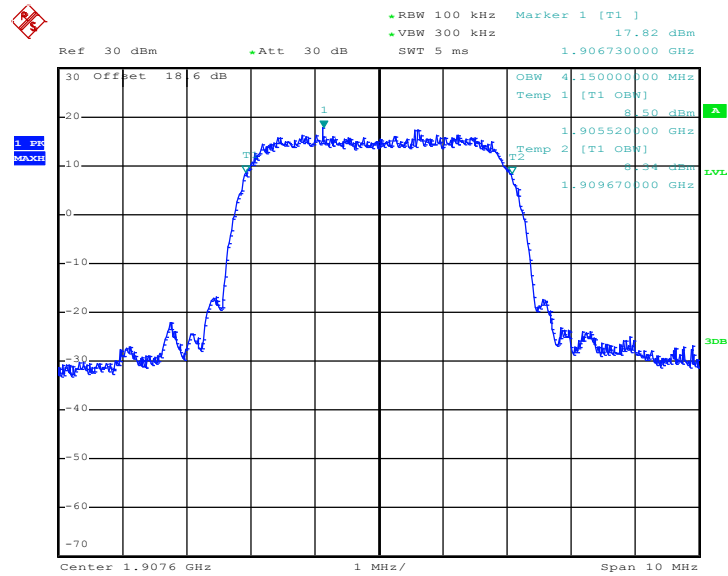

Date: 16.JUN.2015 14:44:02

### 26dB Bandwidth Plot on Channel 9538 (1907.6 MHz)

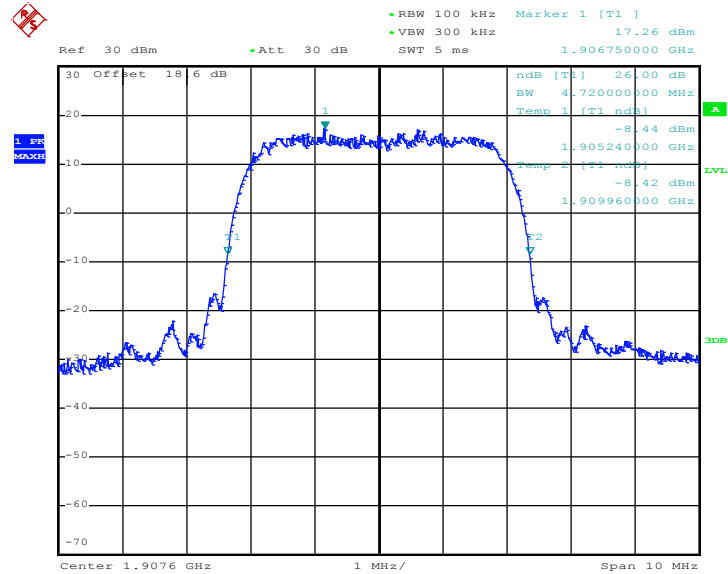

Date: 16.JUN.2015 14:42:30



<b>Band :</b>	CDMA2000 BC0	<b>Test Mode :</b>	1xRTT_RC1+SO55 (QPSK)
---------------	--------------	--------------------	-----------------------

99% Occupied Bandwidth Plot on Channel 1013 (824.7 MHz)

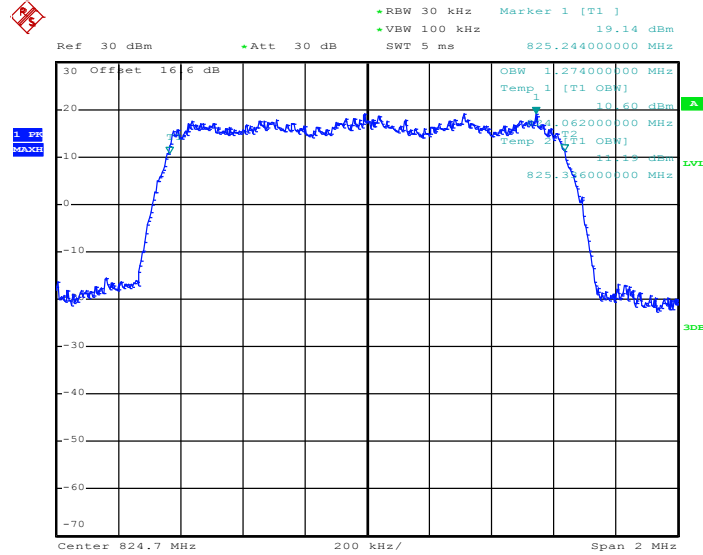

Date: 16.JUN.2015 17:54:20

26dB Bandwidth Plot on Channel 1013 (824.7 MHz)

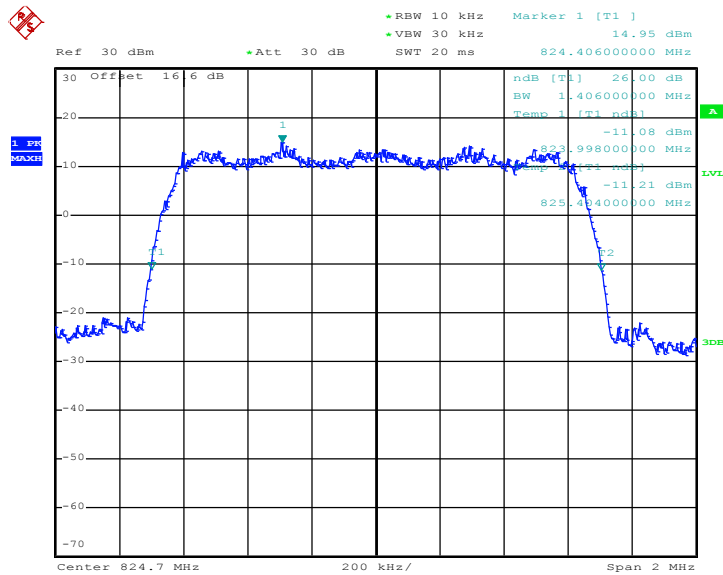

Date: 16.JUN.2015 17:52:07



99% Occupied Bandwidth Plot on Channel 384 (836.52 MHz)

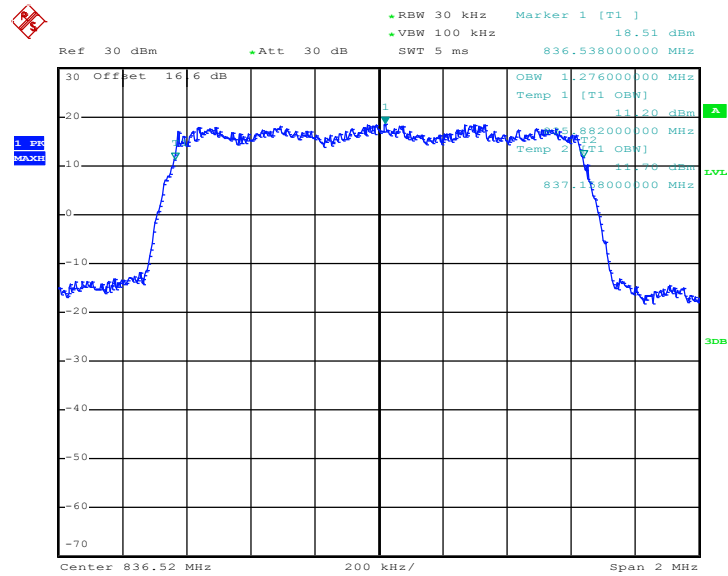

Date: 16.JUN.2015 17:54:56

26dB Bandwidth Plot on Channel 384 (836.52 MHz)

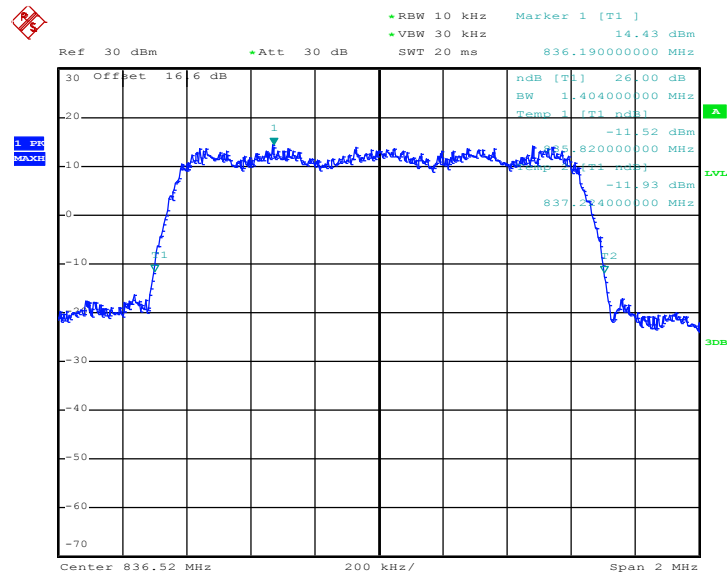

Date: 16.JUN.2015 17:52:39



99% Occupied Bandwidth Plot on Channel 777 (848.31 MHz)

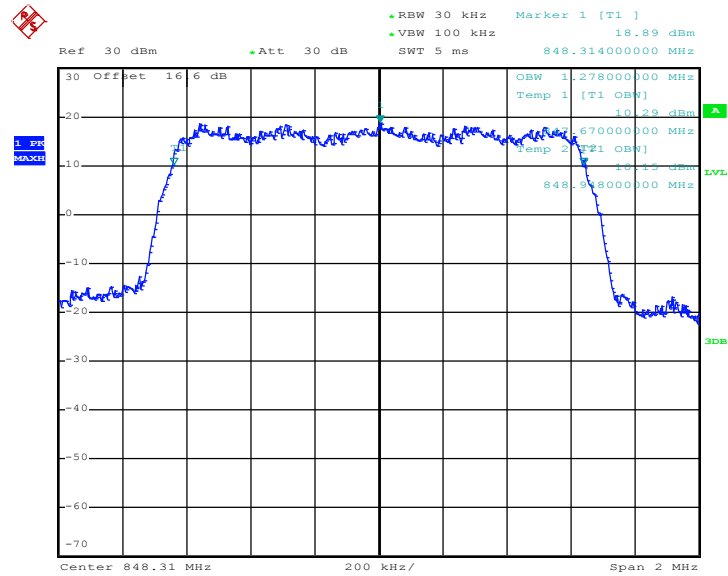

Date: 16.JUN.2015 17:55:25

26dB Bandwidth Plot on Channel 777 (848.31 MHz)

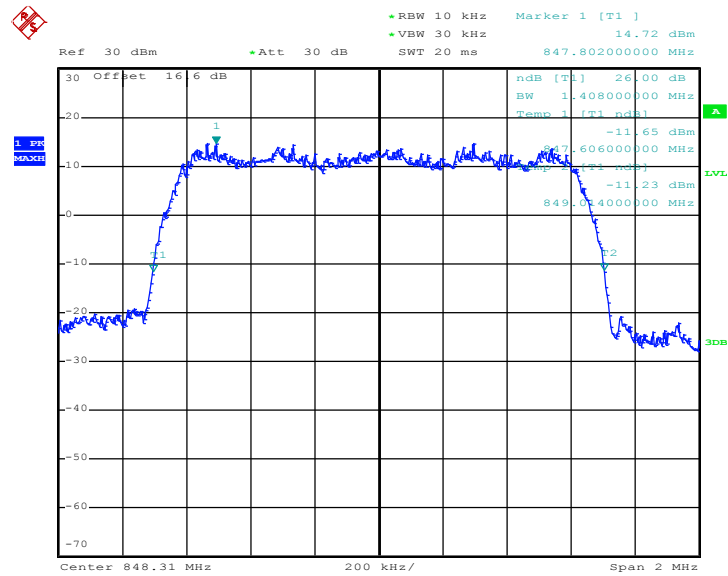

Date: 16.JUN.2015 17:53:10



Band :	CDMA2000 BC0	Test Mode :	1xEV-DO Rev. 0_RTAP 153.6K (QPSK)
--------	--------------	-------------	-----------------------------------

99% Occupied Bandwidth Plot on Channel 1013 (824.7 MHz)

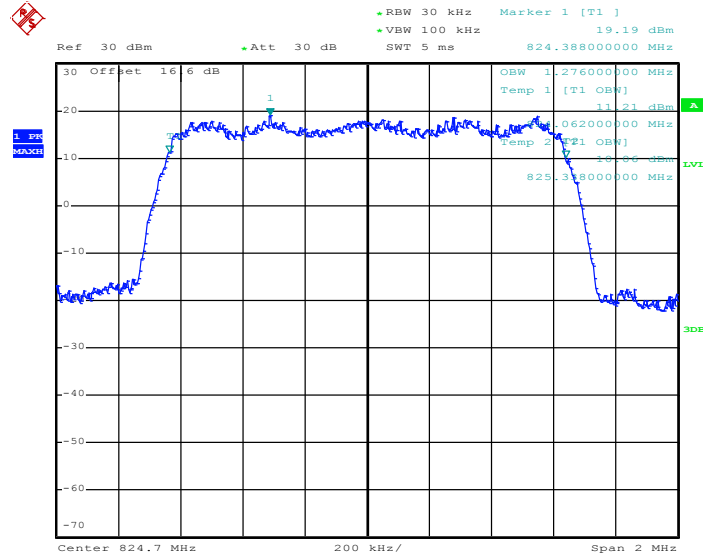

Date: 16.JUN.2015 18:27:24

26dB Bandwidth Plot on Channel 1013 (824.7 MHz)

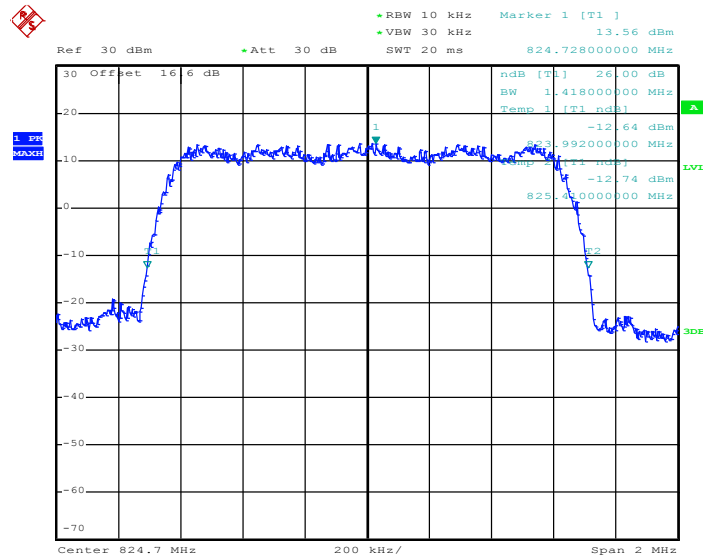

Date: 16.JUN.2015 18:25:29



99% Occupied Bandwidth Plot on Channel 384 (836.52 MHz)

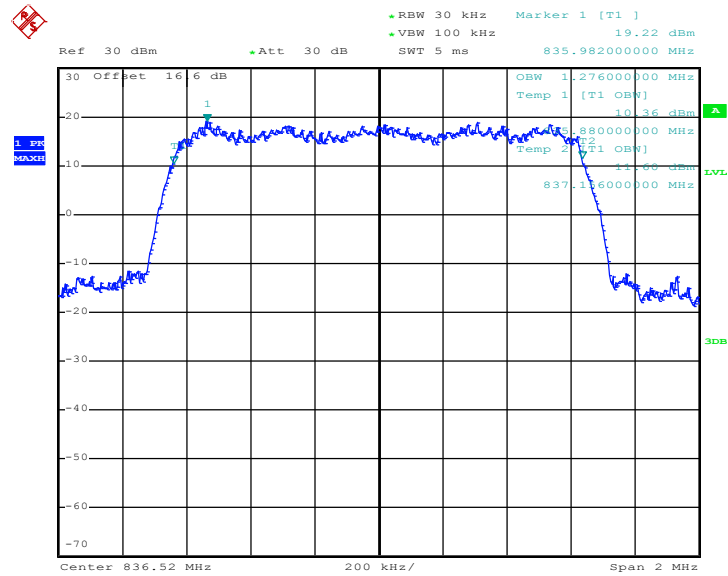

Date: 16.JUN.2015 18:27:52

26dB Bandwidth Plot on Channel 384 (836.52 MHz)

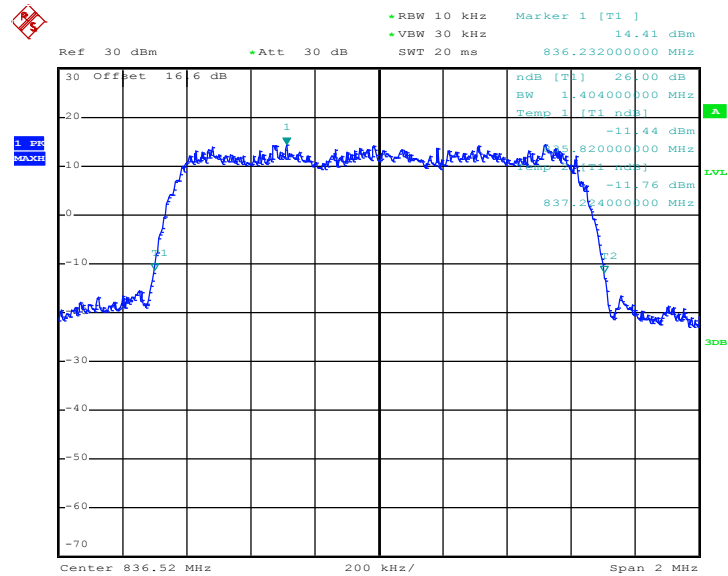

Date: 16.JUN.2015 18:26:01



99% Occupied Bandwidth Plot on Channel 777 (848.31 MHz)

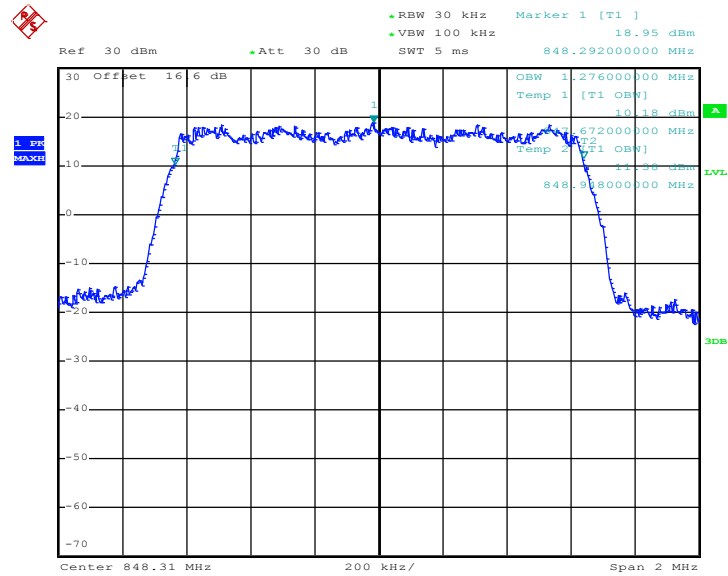

Date: 16.JUN.2015 18:28:23

26dB Bandwidth Plot on Channel 777 (848.31 MHz)

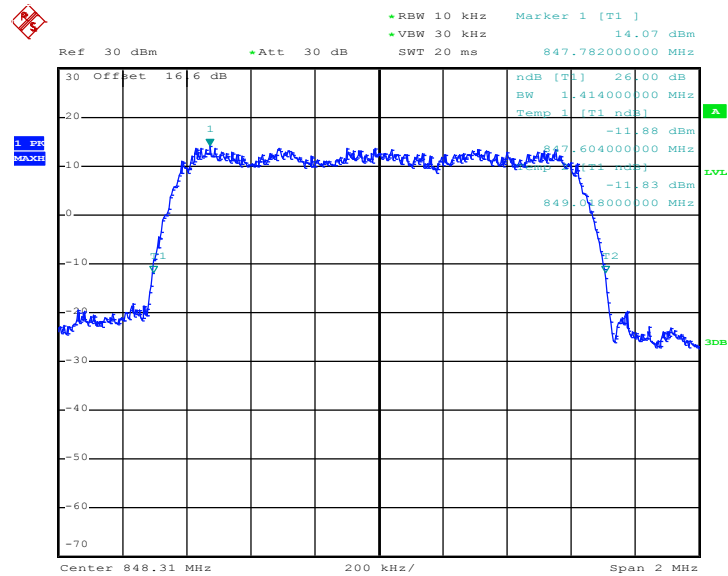

Date: 16.JUN.2015 18:26:34



<b>Band :</b>	CDMA2000 BC1	<b>Test Mode :</b>	1xRTT_RC1+S055 (QPSK)
---------------	--------------	--------------------	-----------------------

99% Occupied Bandwidth Plot on Channel 25 (1851.25 MHz)

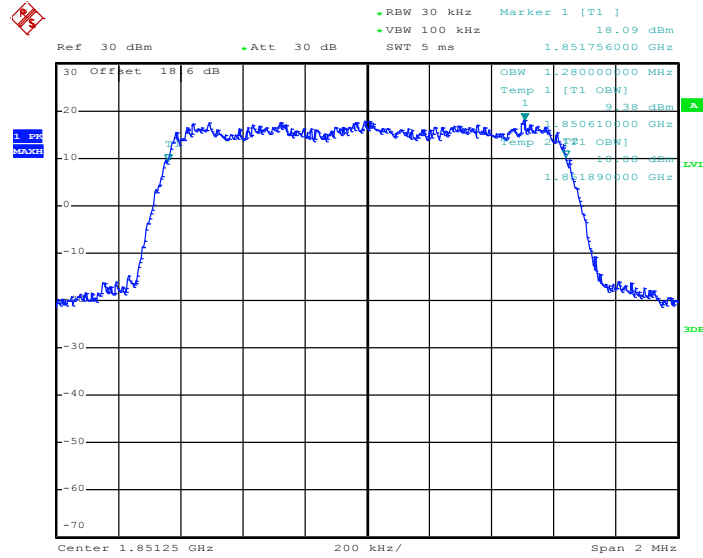

Date: 16.JUN.2015 18:43:15

26dB Bandwidth Plot on Channel 25 (1851.25 MHz)

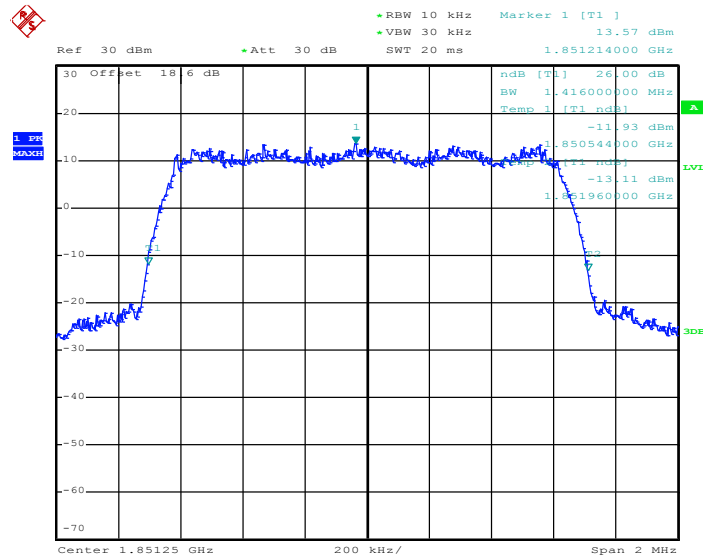

Date: 16.JUN.2015 18:41:37



99% Occupied Bandwidth Plot on Channel 600 (1880.0 MHz)

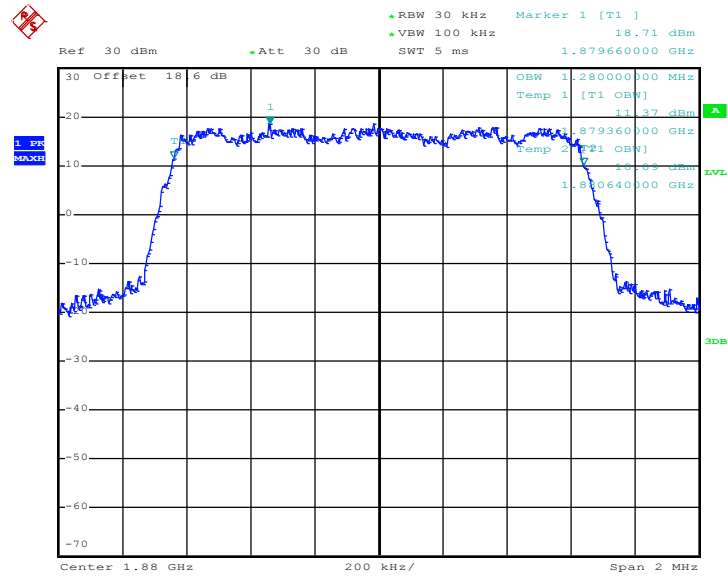

Date: 16.JUN.2015 18:43:44

26dB Bandwidth Plot on Channel 600 (1880.0 MHz)

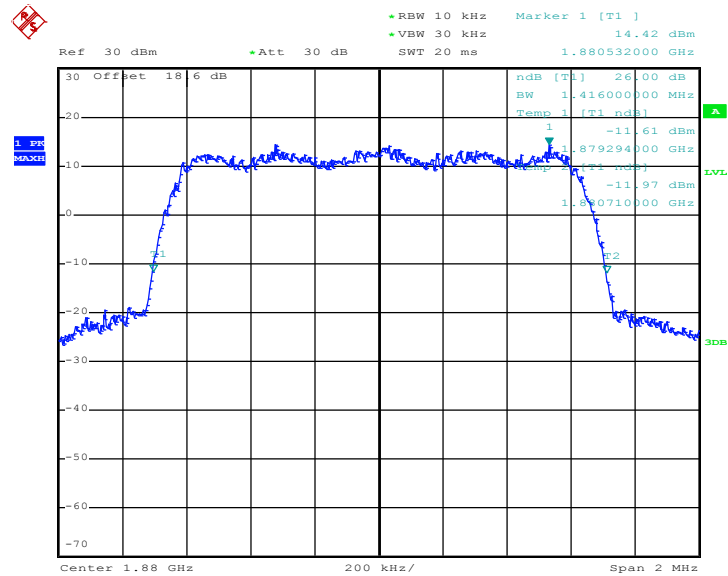

Date: 16.JUN.2015 18:42:09



99% Occupied Bandwidth Plot on Channel 1175 (1908.75 MHz)

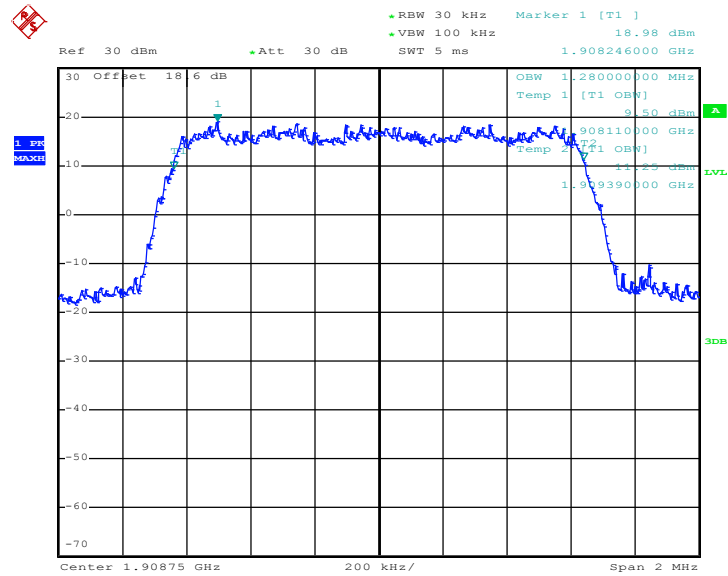

Date: 16.JUN.2015 18:44:13

26dB Bandwidth Plot on Channel 1175 (1908.75 MHz)

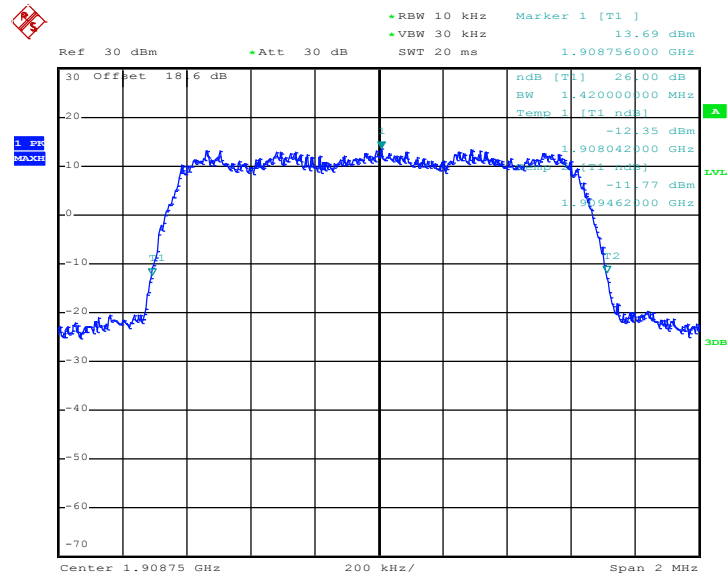

Date: 16.JUN.2015 18:42:38



<b>Band :</b>	CDMA2000 BC1	<b>Test Mode :</b>	1xEV-DO Rev. 0_RTAP 153.6K (QPSK)
---------------	--------------	--------------------	-----------------------------------

99% Occupied Bandwidth Plot on Channel 25 (1851.25 MHz)

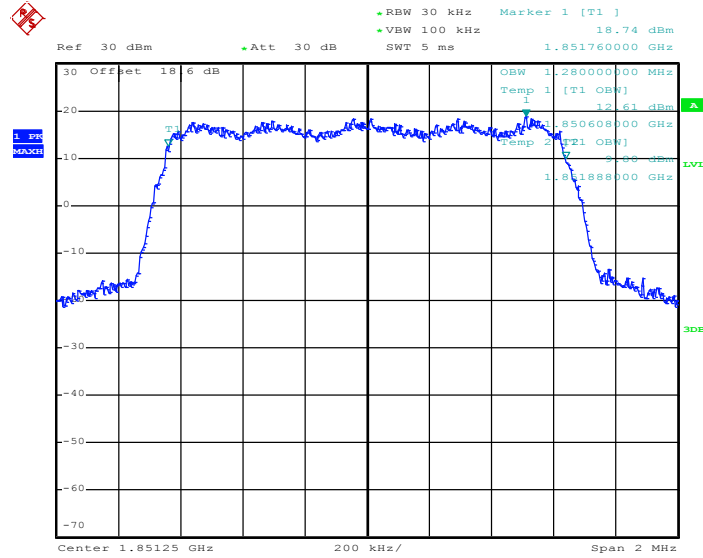

Date: 16.JUN.2015 19:01:07

26dB Bandwidth Plot on Channel 25 (1851.25 MHz)

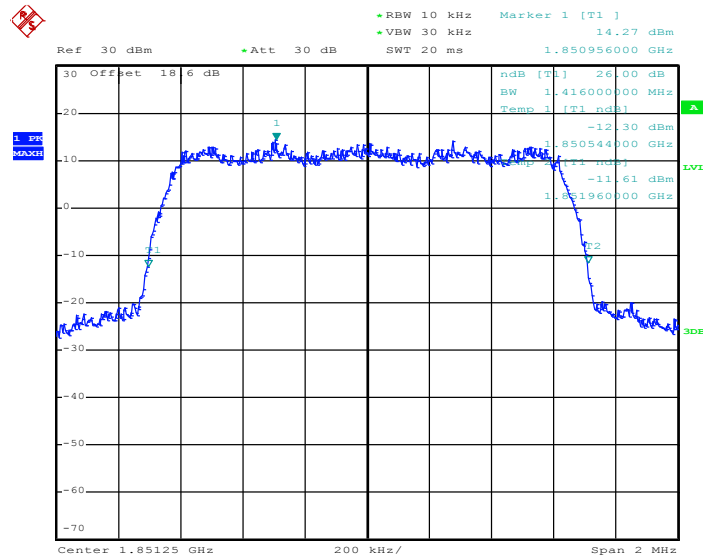

Date: 16.JUN.2015 18:59:29



### 99% Occupied Bandwidth Plot on Channel 600 (1880.0 MHz)

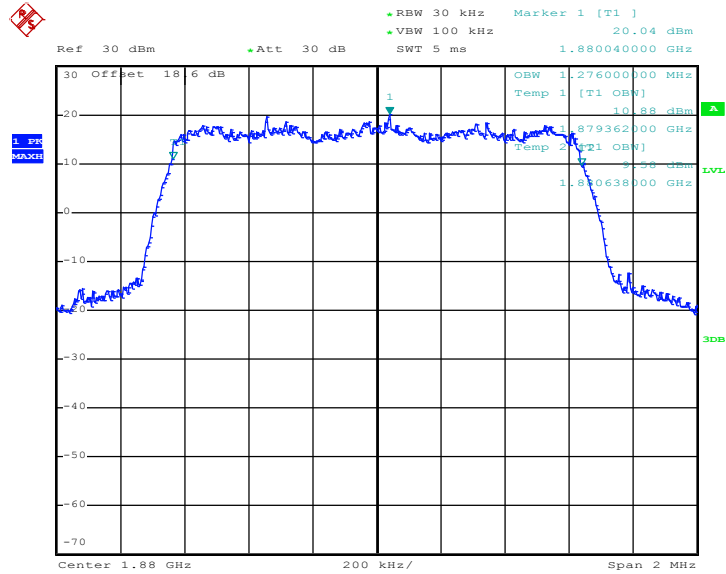

Date: 16.JUN.2015 19:01:38

### 26dB Bandwidth Plot on Channel 600 (1880.0 MHz)

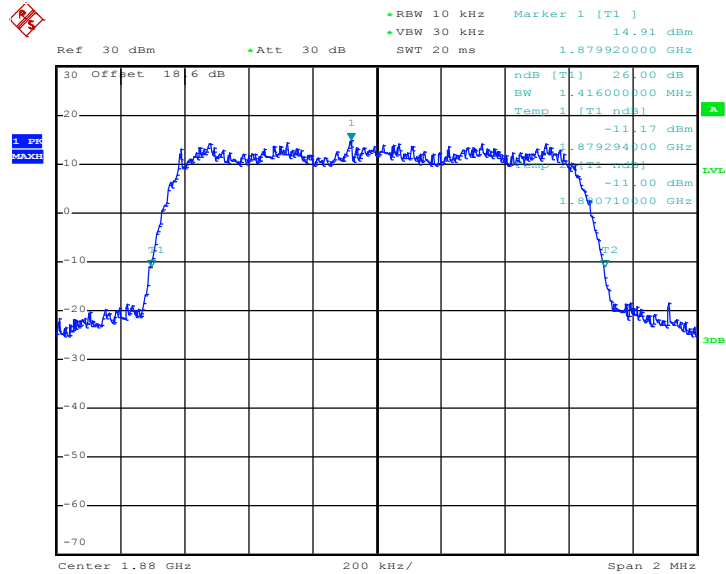

Date: 16.JUN.2015 19:00:00



### 99% Occupied Bandwidth Plot on Channel 1175 (1908.75 MHz)

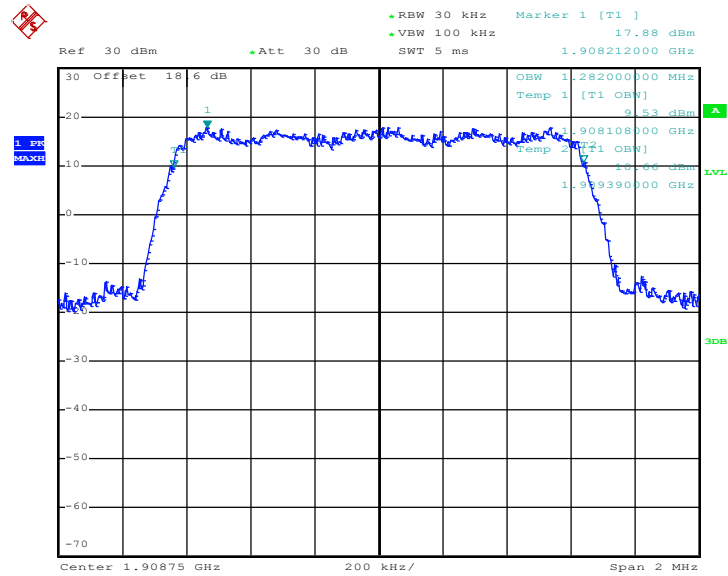

Date: 16.JUN.2015 19:02:09

### 26dB Bandwidth Plot on Channel 1175 (1908.75 MHz)

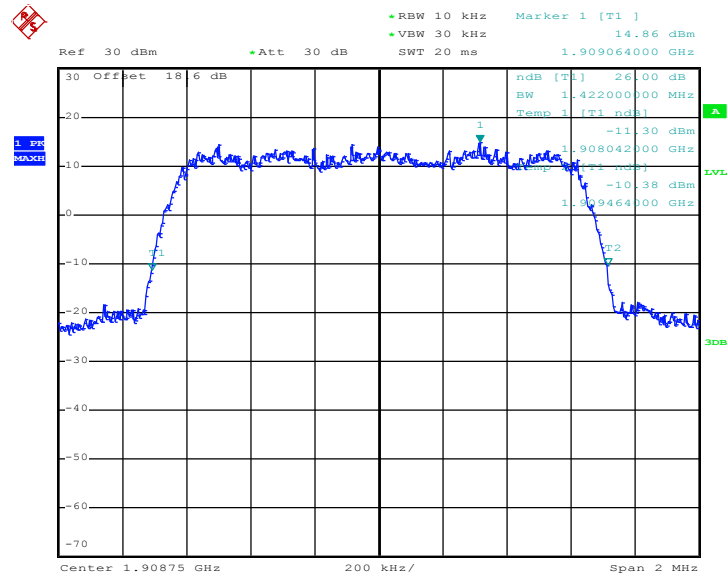

Date: 16.JUN.2015 19:00:32

## 3.5 Band Edge Measurement

### 3.5.1 Description of Band Edge Measurement

The power of any emission outside of the authorized operating frequency ranges must be lower than the transmitter power (P) by a factor of at least  $43 + 10 \log (P)$  dB.

### 3.5.2 Measuring Instruments

The measuring equipment is listed in the section 4 of this test report.

### 3.5.3 Test Procedures

1. The testing follows FCC KDB 971168 v02r02 Section 6.0.
2. The EUT was connected to the spectrum analyzer and system simulator via a power divider.
3. The RF output of EUT was connected to the spectrum analyzer by an RF cable and attenuator. The path loss was compensated to the results for each measurement.
4. The band edges of low and high channels for the highest RF powers were measured.
5. The RF fundamental frequency should be excluded against the limit line in the operating frequency band.
6. The limit line is derived from  $43 + 10\log(P)$  dB below the transmitter power P(Watts)  
 $= P(W) - [43 + 10\log(P)]$  (dB)  
 $= [30 + 10\log(P)]$  (dBm) -  $[43 + 10\log(P)]$  (dB)  
 $= -13\text{dBm}$ .

### 3.5.4 Test Setup

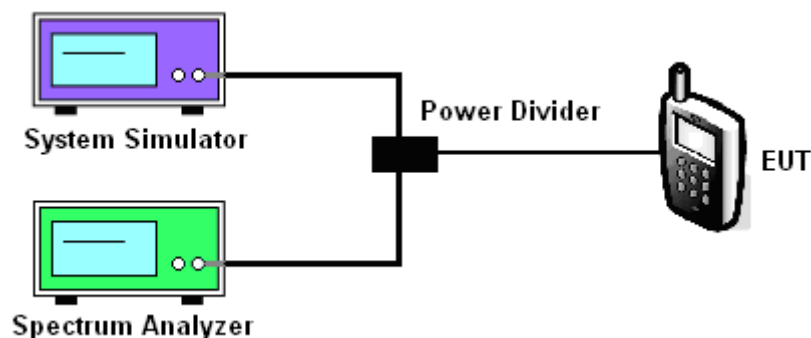



### 3.5.5 Test Result (Plots) of Conducted Band Edge

Band :	GSM850	Test Mode :	GPRS class 8 Link (GMSK)
--------	--------	-------------	--------------------------

#### Lower Band Edge Plot on Channel 128 (824.2 MHz)

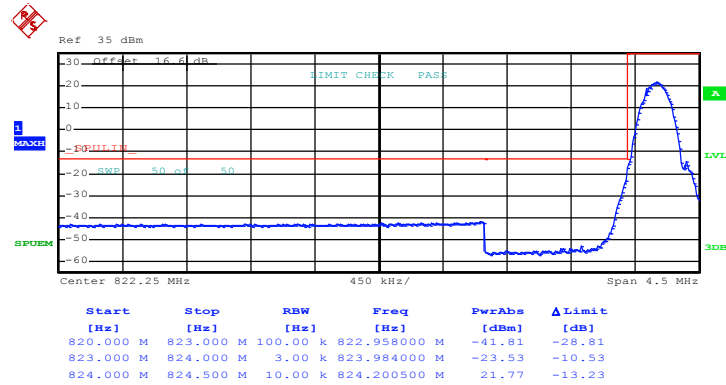

Date: 16.JUN.2015 13:46:35

#### Higher Band Edge Plot on Channel 251 (848.8 MHz)

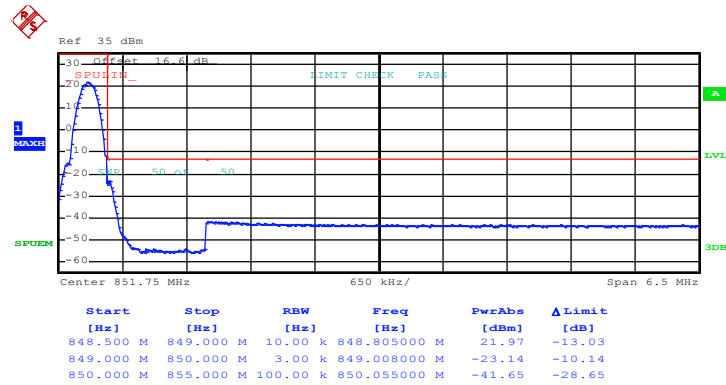

Date: 16.JUN.2015 13:47:57



Band :	GSM850	Test Mode :	EDGE class 8 Link (8PSK)
--------	--------	-------------	--------------------------

Lower Band Edge Plot on Channel 128 (824.2 MHz)

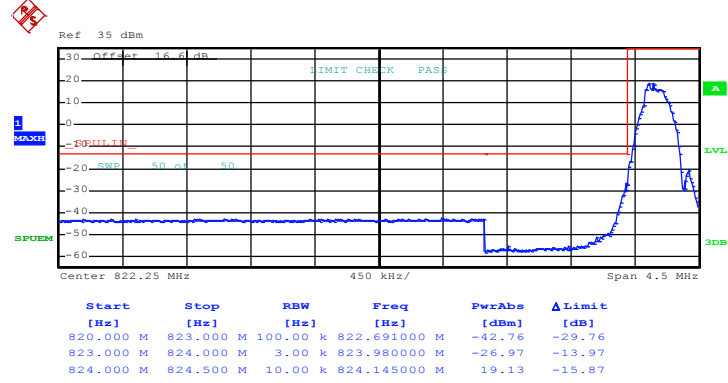

Date: 16.JUN.2015 14:02:11

Higher Band Edge Plot on Channel 251 (848.8 MHz)

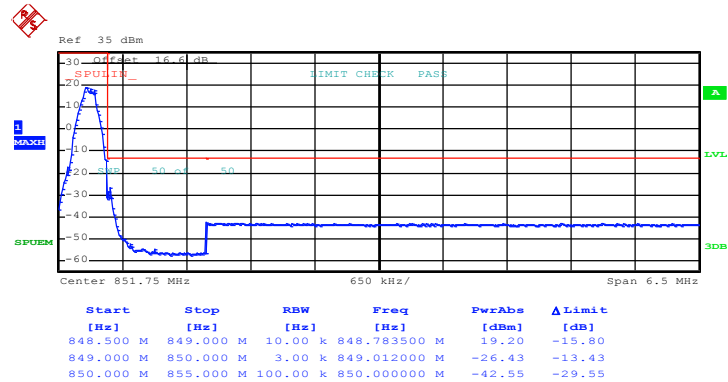

Date: 16.JUN.2015 14:03:34



Band :	GSM1900	Test Mode :	GPRS class 8 Link (GMSK)
--------	---------	-------------	--------------------------

Lower Band Edge Plot on Channel 512 (1850.2 MHz)

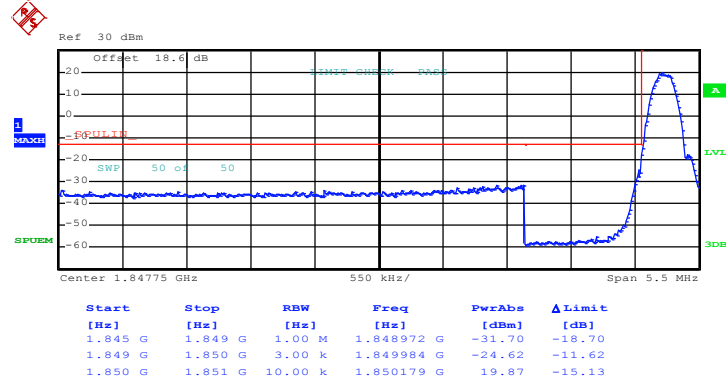

Date: 16.JUN.2015 14:24:28

Higher Band Edge Plot on Channel 810 (1909.8 MHz)

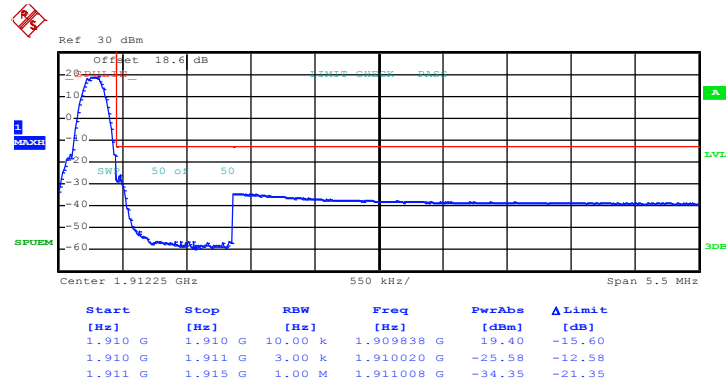

Date: 16.JUN.2015 14:25:51



Band :	GSM1900	Test Mode :	EDGE class 8 Link (8PSK)
--------	---------	-------------	--------------------------

Lower Band Edge Plot on Channel 512 (1850.2 MHz)

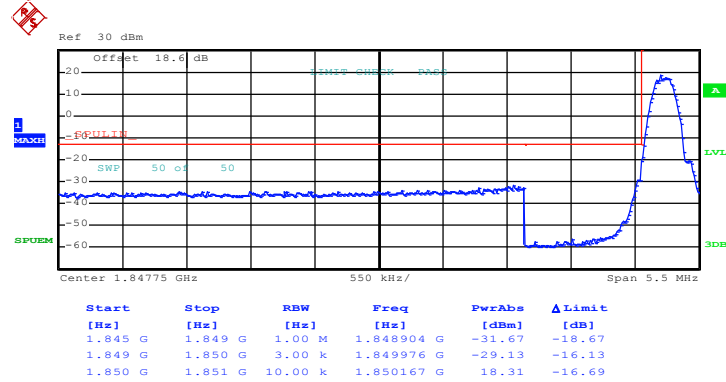

Date: 16.JUN.2015 14:33:56

Higher Band Edge Plot on Channel 810 (1909.8 MHz)

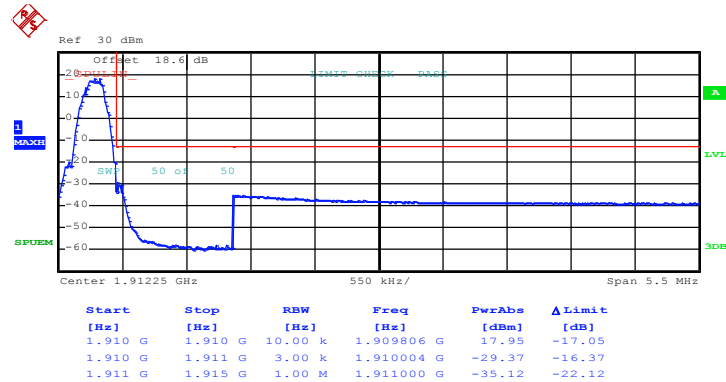

Date: 16.JUN.2015 14:35:18



Band :	WCDMA Band V	Test Mode :	RMC 12.2Kbps Link (QPSK)
--------	--------------	-------------	--------------------------

Lower Band Edge Plot on Channel 4132 (826.4 MHz)

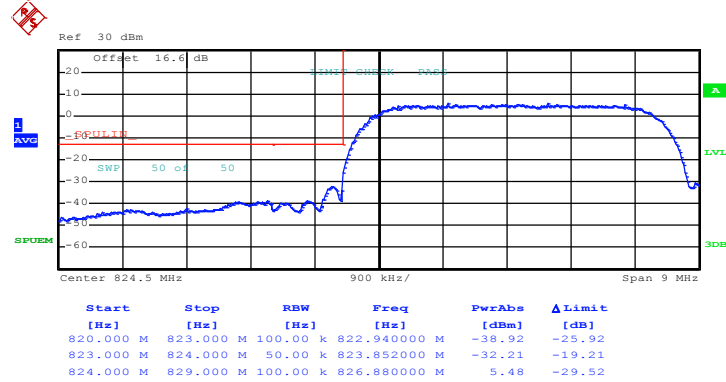

Date: 16.JUN.2015 14:12:52

Higher Band Edge Plot on Channel 4233 (846.6 MHz)

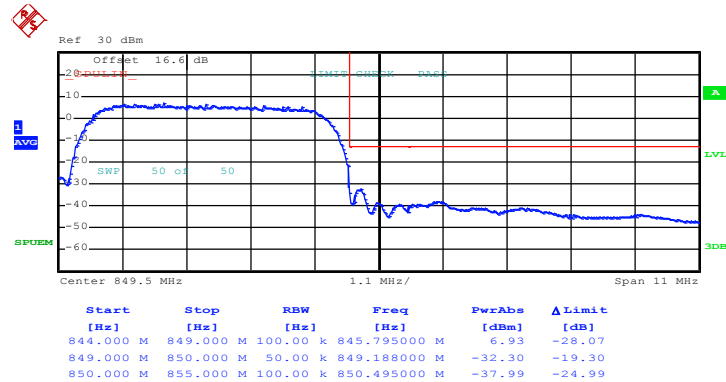

Date: 16.JUN.2015 14:14:14



Band :	WCDMA Band II	Test Mode :	RMC 12.2Kbps Link (QPSK)
--------	---------------	-------------	--------------------------

Lower Band Edge Plot on Channel 9262 (1852.4 MHz)

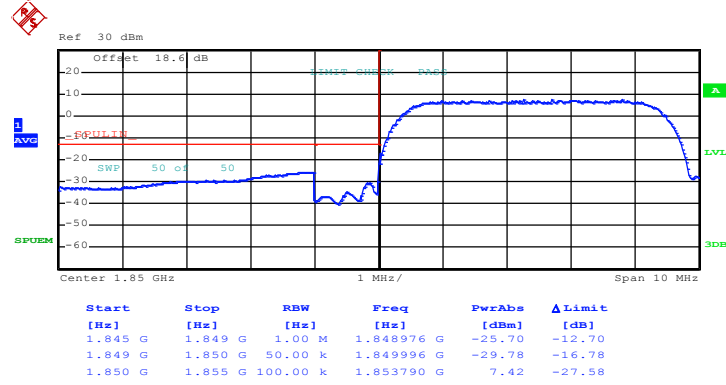

Date: 16.JUN.2015 14:45:30

Higher Band Edge Plot on Channel 9538 (1907.6 MHz)

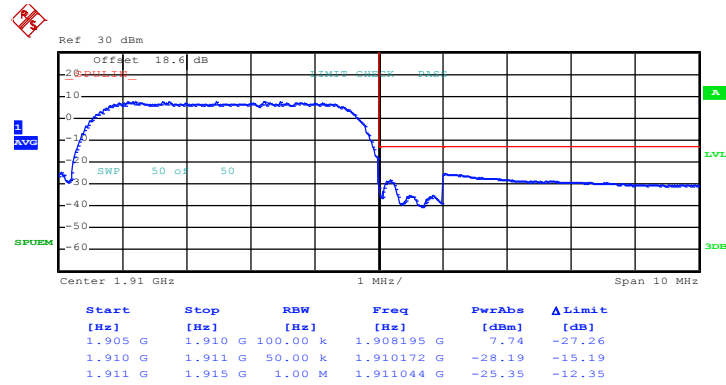

Date: 16.JUN.2015 14:46:51



Band :	CDMA2000 BC0	Test Mode :	1xRTT_RC1+SO55 (QPSK)
--------	--------------	-------------	-----------------------

Lower Band Edge Plot on Channel 1013 (824.7 MHz)

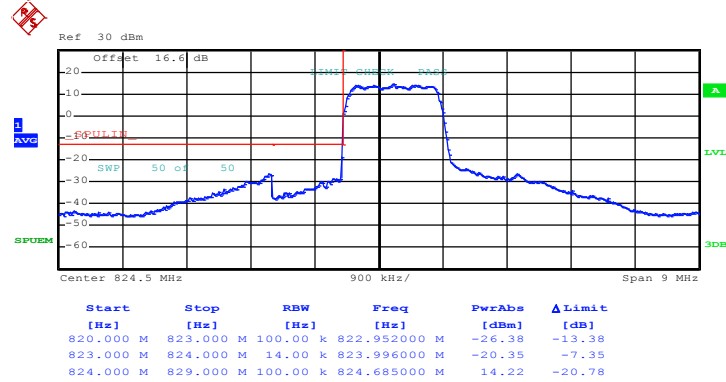

Date: 16.JUN.2015 19:52:27

Higher Band Edge Plot on Channel 777 (848.31 MHz)

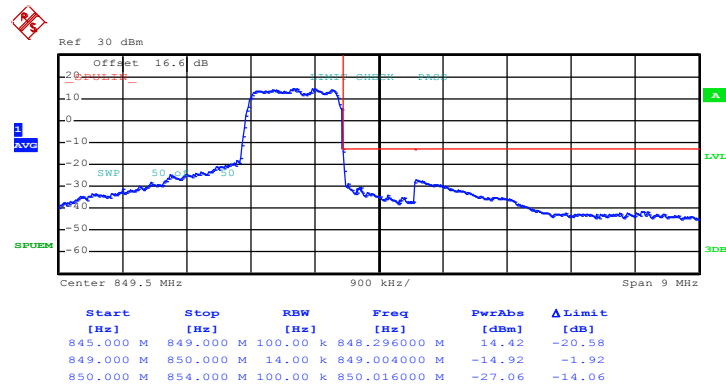

Date: 16.JUN.2015 20:00:26



Band :	CDMA2000 BC0	Test Mode :	1xEV-DO Rev. 0_RTAP 153.6K (QPSK)
--------	--------------	-------------	-----------------------------------

Lower Band Edge Plot on Channel 1013 (824.7 MHz)

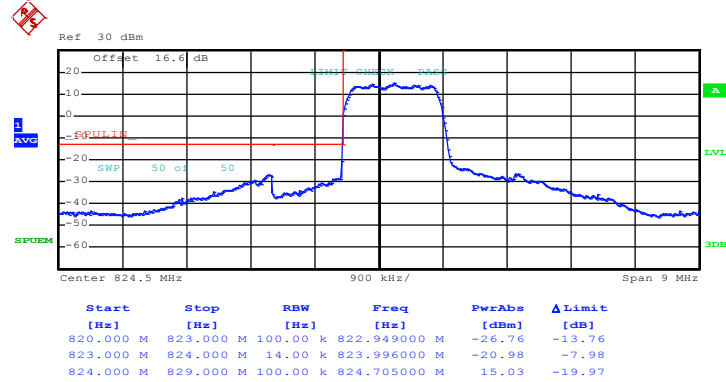

Date: 16.JUN.2015 19:57:08

Higher Band Edge Plot on Channel 777 (848.31 MHz)

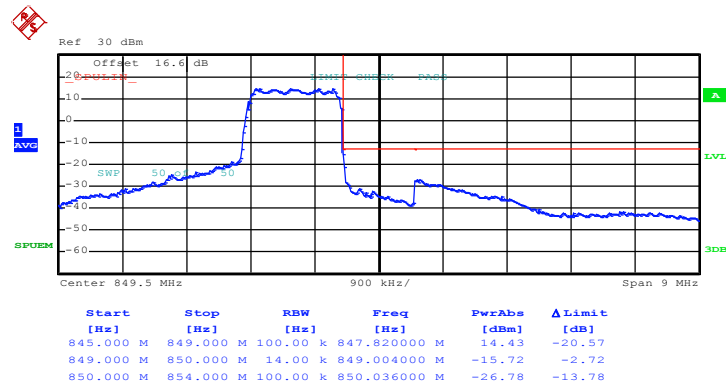

Date: 16.JUN.2015 20:05:01



Band :	CDMA2000 BC1	Test Mode :	1xRTT_RC1+SO55 (QPSK)
--------	--------------	-------------	-----------------------

Lower Band Edge Plot on Channel 25 (1851.25 MHz)

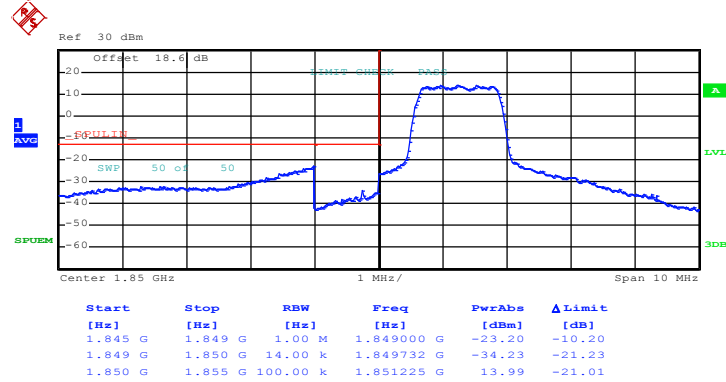

Date: 16.JUN.2015 19:17:05

Higher Band Edge Plot on Channel 1175 (1908.75 MHz)

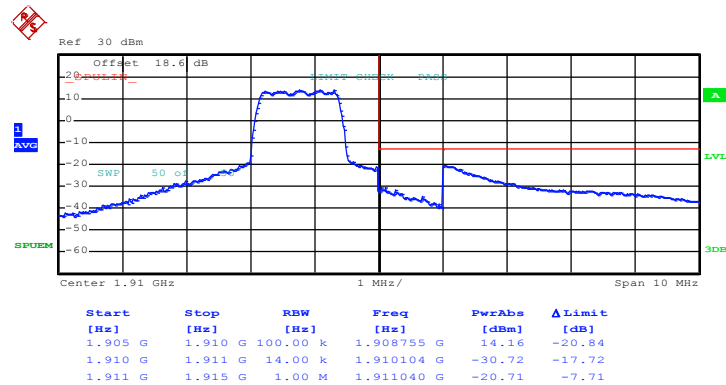

Date: 16.JUN.2015 19:25:38



Band :	CDMA2000 BC1	Test Mode :	1xEV-DO Rev. 0_RTAP 153.6K (QPSK)
--------	--------------	-------------	-----------------------------------

Lower Band Edge Plot on Channel 25 (1851.25 MHz)

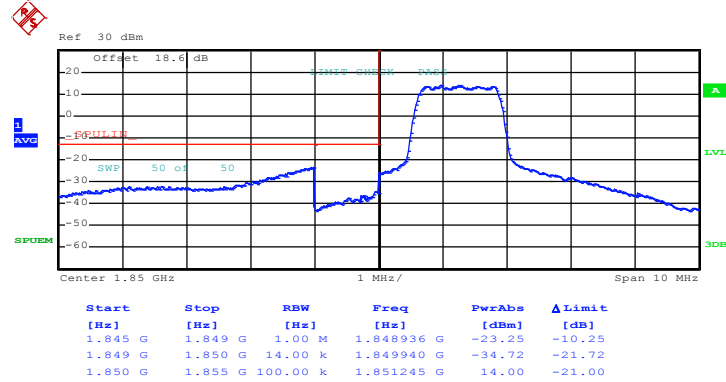

Date: 16.JUN.2015 19:22:22

Higher Band Edge Plot on Channel 1175 (1908.75 MHz)

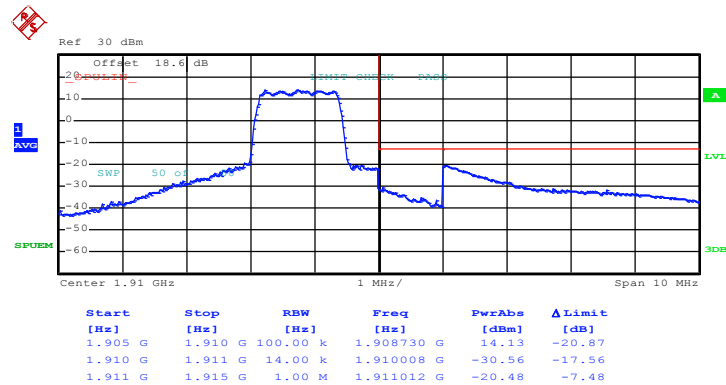

Date: 16.JUN.2015 19:33:03

## 3.6 Conducted Spurious Emission Measurement

### 3.6.1 Description of Conducted Spurious Emission Measurement

The power of any emission outside of the authorized operating frequency ranges must be lower than the transmitter power (P) by a factor of at least  $43 + 10 \log (P)$  dB.

It is measured by means of a calibrated spectrum analyzer and scanned from 30 MHz up to a frequency including its 10<sup>th</sup> harmonic.

### 3.6.2 Measuring Instruments

The measuring equipment is listed in the section 4 of this test report.

### 3.6.3 Test Procedures

1. The testing follows FCC KDB 971168 v02r02 Section 6.0.
2. The EUT was connected to the spectrum analyzer and system simulator via a power divider.
3. The RF output of EUT was connected to the spectrum analyzer by an RF cable and attenuator. The path loss was compensated to the results for each measurement.
4. The middle channel for the highest RF power within the transmitting frequency was measured.
5. The conducted spurious emission for the whole frequency range was taken.
6. The RF fundamental frequency should be excluded against the limit line in the operating frequency band.
7. The limit line is derived from  $43 + 10\log(P)$  dB below the transmitter power P(Watts)  
 $= P(W) - [43 + 10\log(P)]$  (dB)  
 $= [30 + 10\log(P)]$  (dBm) -  $[43 + 10\log(P)]$  (dB)  
 $= -13\text{dBm}$ .

### 3.6.4 Test Setup

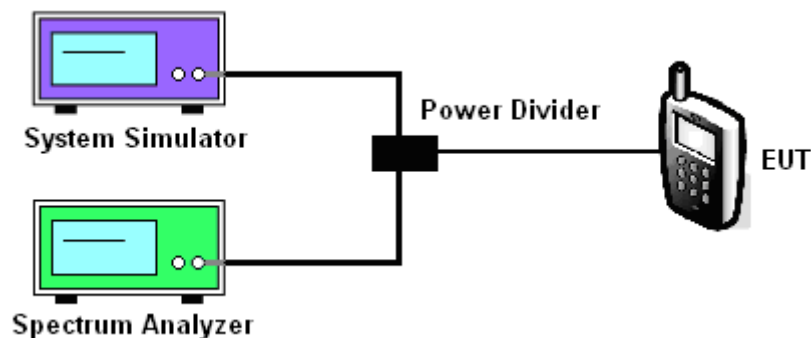



### 3.6.5 Test Result (Plots) of Conducted Spurious Emission

Band :	GSM850	Channel :	CH128
Test Mode :	GPRS class 8 Link (GMSK)	Frequency :	824.2 MHz

Conducted Spurious Emission Plot between 30MHz ~ 9GHz

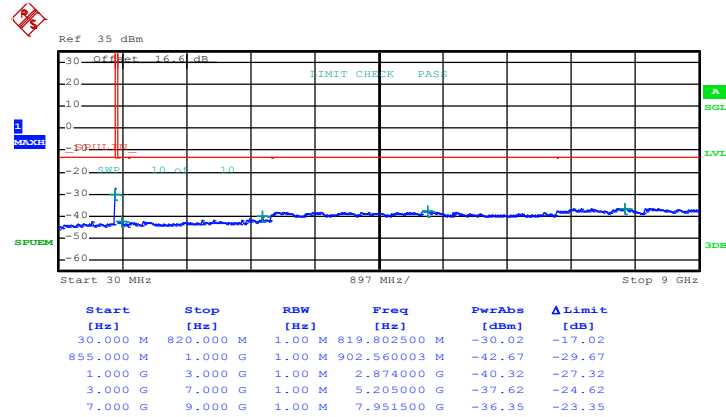

Date: 16.JUN.2015 13:48:36



<b>Band :</b>	GSM850	<b>Channel :</b>	CH189
<b>Test Mode :</b>	GPRS class 8 Link (GMSK)	<b>Frequency :</b>	836.4 MHz

Conducted Spurious Emission Plot between 30MHz ~ 9GHz

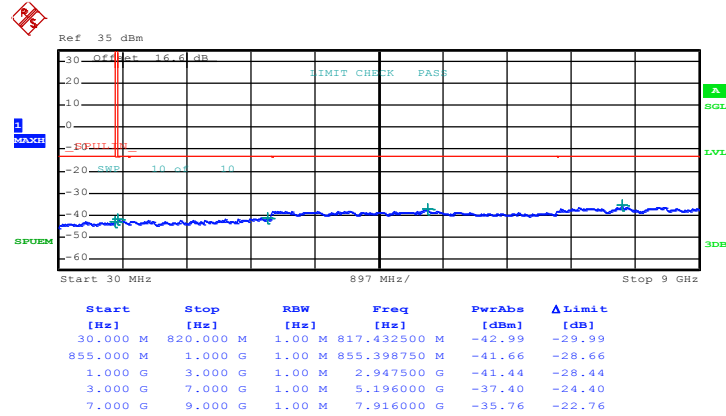

Date: 16.JUN.2015 13:49:01



<b>Band :</b>	GSM850	<b>Channel :</b>	CH251
<b>Test Mode :</b>	GPRS class 8 Link (GMSK)	<b>Frequency :</b>	848.8 MHz

Conducted Spurious Emission Plot between 30MHz ~ 9GHz

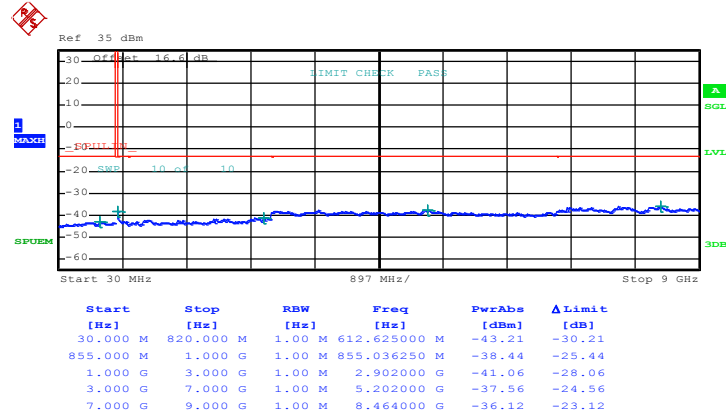

Date: 16.JUN.2015 13:49:26



<b>Band :</b>	GSM850	<b>Channel :</b>	CH128
<b>Test Mode :</b>	EDGE class 8 Link (8PSK)	<b>Frequency :</b>	824.2 MHz

Conducted Spurious Emission Plot between 30MHz ~ 9GHz

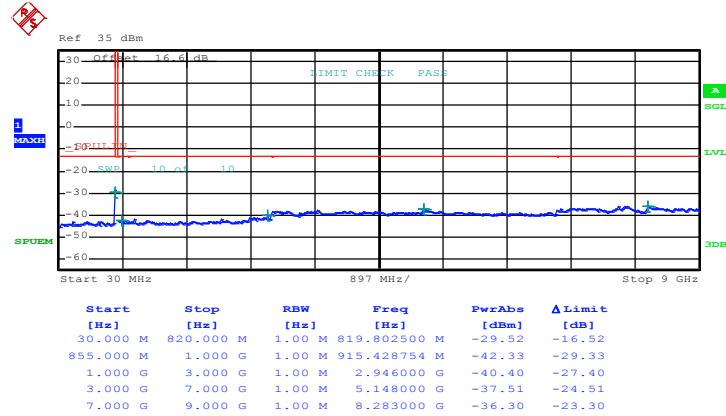

Date: 16.JUN.2015 14:04:08



<b>Band :</b>	GSM850	<b>Channel :</b>	CH189
<b>Test Mode :</b>	EDGE class 8 Link (8PSK)	<b>Frequency :</b>	836.4 MHz

Conducted Spurious Emission Plot between 30MHz ~ 9GHz

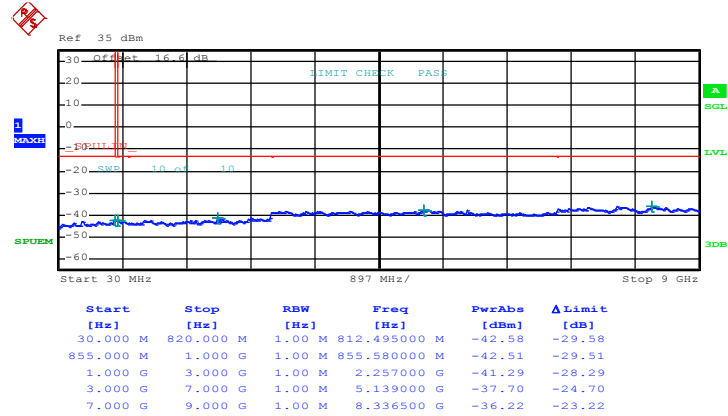

Date: 16.JUN.2015 14:04:33



<b>Band :</b>	GSM850	<b>Channel :</b>	CH251
<b>Test Mode :</b>	EDGE class 8 Link (8PSK)	<b>Frequency :</b>	848.8 MHz

Conducted Spurious Emission Plot between 30MHz ~ 9GHz

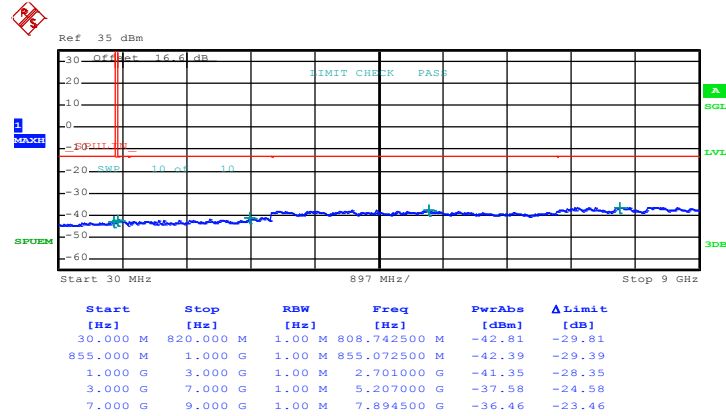

Date: 16.JUN.2015 14:04:58



<b>Band :</b>	GSM1900	<b>Channel :</b>	CH512
<b>Test Mode :</b>	GPRS class 8 Link (GMSK)	<b>Frequency :</b>	1850.2 MHz

Conducted Spurious Emission Plot between 30MHz ~ 19.1GHz

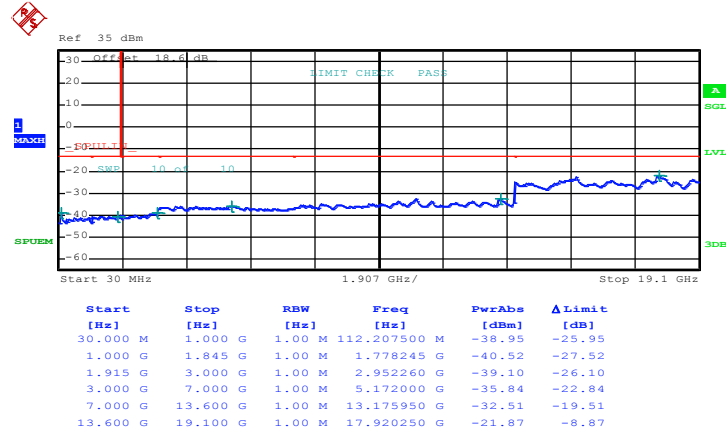

Date: 16.JUN.2015 14:26:43



<b>Band :</b>	GSM1900	<b>Channel :</b>	CH661
<b>Test Mode :</b>	GPRS class 8 Link (GMSK)	<b>Frequency :</b>	1880.0 MHz

**Conducted Spurious Emission Plot between 30MHz ~ 19.1GHz**

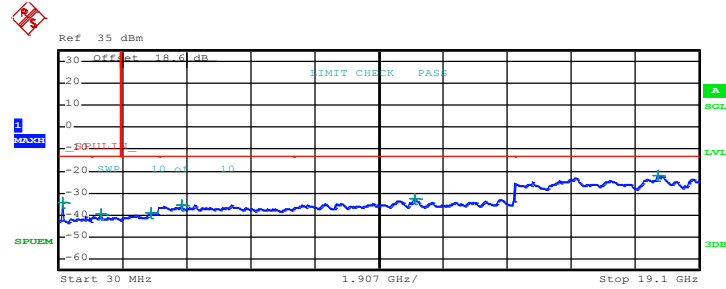

Start [Hz]	Stop [Hz]	RBW [Hz]	Freq [Hz]	PwrAbs [dBm]	Δ Limit [dB]
30.000 M	1.000 G	1.00 M	141.792500 M	-34.52	-21.52
1.000 G	1.845 G	1.00 M	1.276949 G	-39.64	-26.64
1.915 G	3.000 G	1.00 M	2.783542 G	-38.87	-25.87
3.000 G	7.000 G	1.00 M	3.688000 G	-35.41	-22.41
7.000 G	13.600 G	1.00 M	10.641550 G	-32.81	-19.81
13.600 G	19.100 G	1.00 M	17.865250 G	-22.00	-9.00

Date: 16.JUN.2015 14:27:09



<b>Band :</b>	GSM1900	<b>Channel :</b>	CH810
<b>Test Mode :</b>	GPRS class 8 Link (GMSK)	<b>Frequency :</b>	1909.8 MHz

Conducted Spurious Emission Plot between 30MHz ~ 19.1GHz

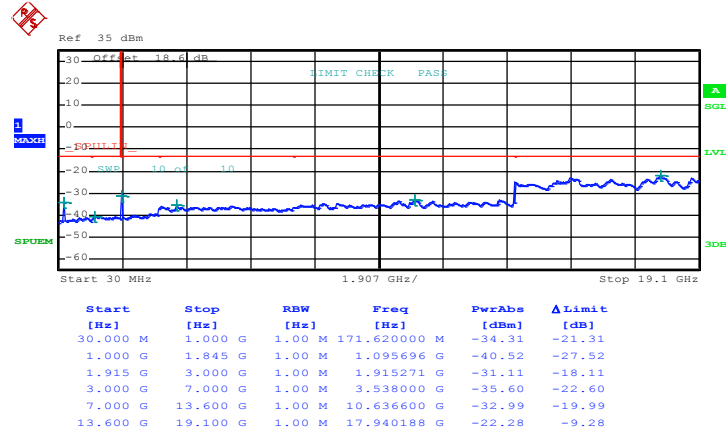

Date: 16.JUN.2015 14:27:34



<b>Band :</b>	GSM1900	<b>Channel :</b>	CH512
<b>Test Mode :</b>	EDGE class 8 Link (8PSK)	<b>Frequency :</b>	1850.2 MHz

Conducted Spurious Emission Plot between 30MHz ~ 19.1GHz

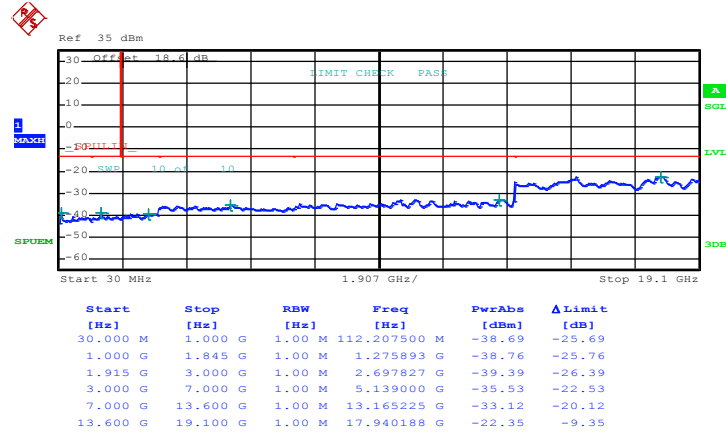

Date: 16.JUN.2015 14:36:12



<b>Band :</b>	GSM1900	<b>Channel :</b>	CH661
<b>Test Mode :</b>	EDGE class 8 Link (8PSK)	<b>Frequency :</b>	1880.0 MHz

Conducted Spurious Emission Plot between 30MHz ~ 19.1GHz

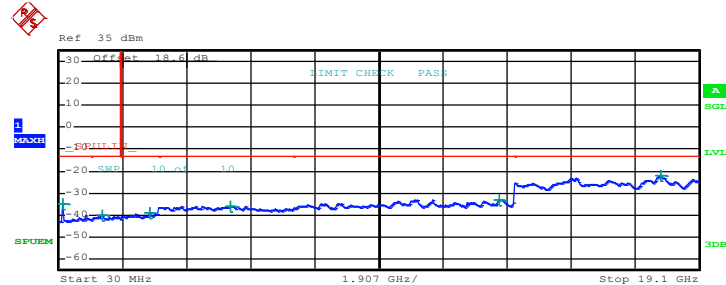

Start [Hz]	Stop [Hz]	RBW [Hz]	Freq [Hz]	PwrAbs [dBm]	Δ Limit [dB]
30.000 M	1.000 G	1.00 M	141.792500 M	-34.71	-21.71
1.000 G	1.845 G	1.00 M	1.314129 G	-40.09	-27.09
1.915 G	3.000 G	1.00 M	2.722240 G	-38.87	-25.87
3.000 G	7.000 G	1.00 M	5.137000 G	-35.76	-22.76
7.000 G	13.600 G	1.00 M	13.165225 G	-32.97	-19.97
13.600 G	19.100 G	1.00 M	17.943625 G	-22.22	-9.22

Date: 16.JUN.2015 14:36:38



<b>Band :</b>	GSM1900	<b>Channel :</b>	CH810
<b>Test Mode :</b>	EDGE class 8 Link (8PSK)	<b>Frequency :</b>	1909.8 MHz

Conducted Spurious Emission Plot between 30MHz ~ 19.1GHz

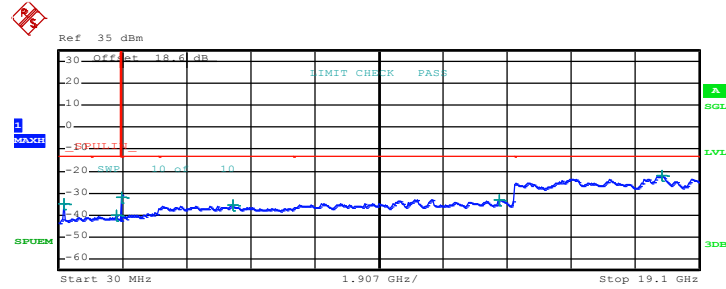

Start [Hz]	Stop [Hz]	RBW [Hz]	Freq [Hz]	PwrAbs [dBm]	Δ Limit [dB]
30.000 M	1.000 G	1.00 M	171.620000 M	-34.95	-21.95
1.000 G	1.845 G	1.00 M	1.730503 G	-40.43	-27.43
1.915 G	3.000 G	1.00 M	1.915271 G	-32.12	-19.12
3.000 G	7.000 G	1.00 M	5.202000 G	-35.20	-22.20
7.000 G	13.600 G	1.00 M	13.168525 G	-32.97	-19.97
13.600 G	19.100 G	1.00 M	18.006187 G	-22.04	-9.04

Date: 16.JUN.2015 14:37:04



<b>Band :</b>	WCDMA Band V	<b>Channel :</b>	CH4132
<b>Test Mode :</b>	RMC 12.2Kbps Link (QPSK)	<b>Frequency :</b>	826.4 MHz

**Conducted Spurious Emission Plot between 30MHz ~ 9GHz**

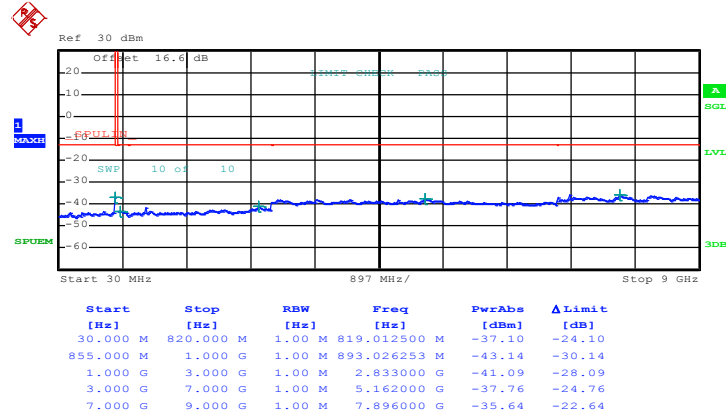

Date: 16.JUN.2015 14:15:11



<b>Band :</b>	WCDMA Band V	<b>Channel :</b>	CH4182
<b>Test Mode :</b>	RMC 12.2Kbps Link (QPSK)	<b>Frequency :</b>	836.4 MHz

Conducted Spurious Emission Plot between 30MHz ~ 9GHz

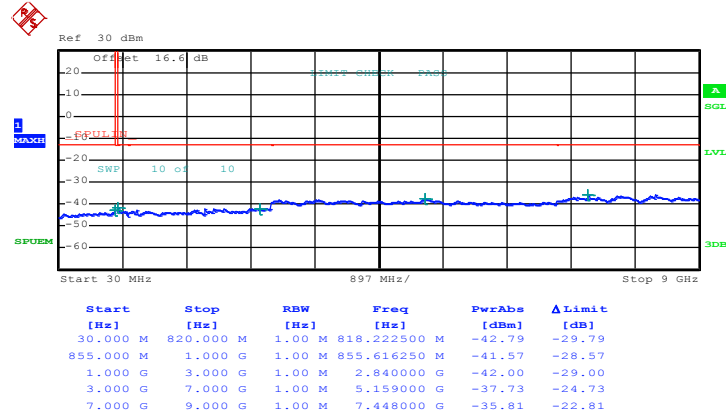

Date: 16.JUN.2015 14:15:36



<b>Band :</b>	WCDMA Band V	<b>Channel :</b>	CH4233
<b>Test Mode :</b>	RMC 12.2Kbps Link (QPSK)	<b>Frequency :</b>	846.6 MHz

**Conducted Spurious Emission Plot between 30MHz ~ 9GHz**

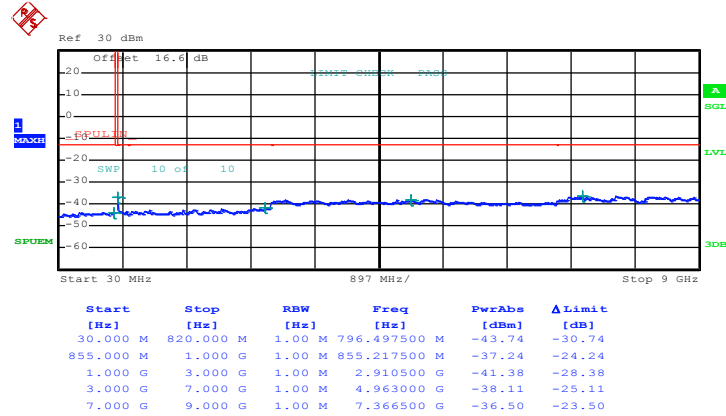

Date: 16.JUN.2015 14:16:01



<b>Band :</b>	WCDMA Band II	<b>Channel :</b>	CH9262
<b>Test Mode :</b>	RMC 12.2Kbps Link (QPSK)	<b>Frequency :</b>	1852.4 MHz

Conducted Spurious Emission Plot between 30MHz ~ 19.1GHz

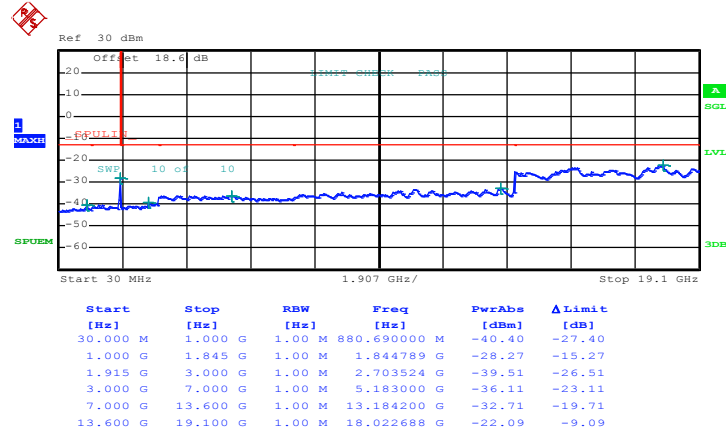

Date: 16.JUN.2015 14:47:44



<b>Band :</b>	WCDMA Band II	<b>Channel :</b>	CH9400
<b>Test Mode :</b>	RMC 12.2Kbps Link (QPSK)	<b>Frequency :</b>	1880.0 MHz

Conducted Spurious Emission Plot between 30MHz ~ 19.1GHz

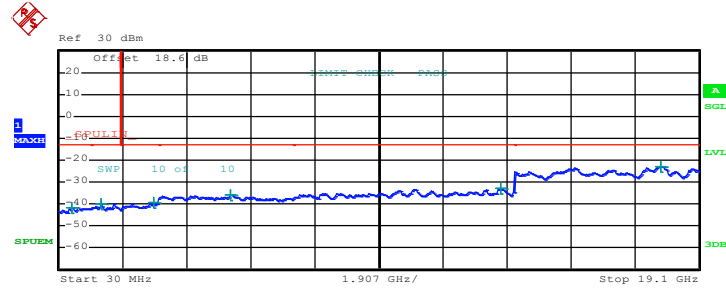

Start [Hz]	Stop [Hz]	RBW [Hz]	Freq [Hz]	PwrAbs [dBm]	Δ Limit [dB]
30.000 M	1.000 G	1.00 M	398.115000 M	-41.42	-28.42
1.000 G	1.845 G	1.00 M	1.269978 G	-39.69	-26.69
1.915 G	3.000 G	1.00 M	2.842404 G	-39.17	-26.17
3.000 G	7.000 G	1.00 M	5.158000 G	-36.02	-23.02
7.000 G	13.600 G	1.00 M	13.171000 G	-33.00	-20.00
13.600 G	19.100 G	1.00 M	17.955313 G	-22.68	-9.68

Date: 16.JUN.2015 14:48:10



<b>Band :</b>	WCDMA Band II	<b>Channel :</b>	CH9538
<b>Test Mode :</b>	RMC 12.2Kbps Link (QPSK)	<b>Frequency :</b>	1907.6 MHz

**Conducted Spurious Emission Plot between 30MHz ~ 19.1GHz**

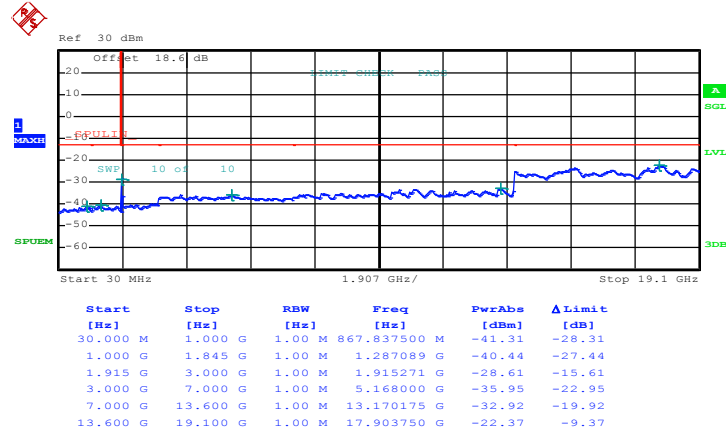

Date: 16.JUN.2015 14:48:35



<b>Band :</b>	CDMA2000 BC0	<b>Channel :</b>	CH1013
<b>Test Mode :</b>	1xRTT_RC1+SO55 (QPSK)	<b>Frequency :</b>	824.7 MHz

Conducted Spurious Emission Plot between 30MHz ~ 9GHz

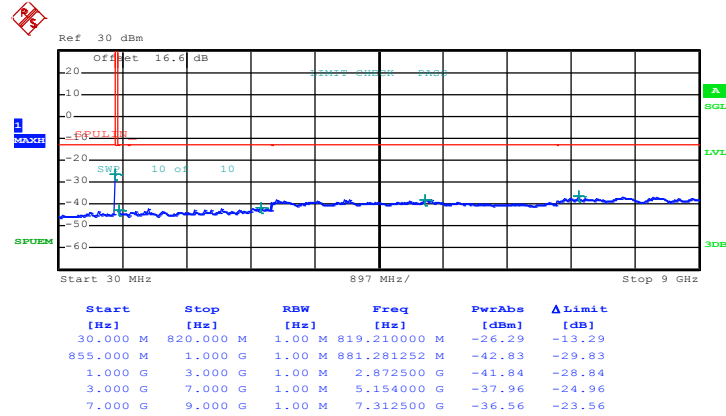

Date: 16.JUN.2015 17:59:10



<b>Band :</b>	CDMA2000 BC0	<b>Channel :</b>	CH384
<b>Test Mode :</b>	1xRTT_RC1+SO55 (QPSK)	<b>Frequency :</b>	836.52 MHz

Conducted Spurious Emission Plot between 30MHz ~ 9GHz

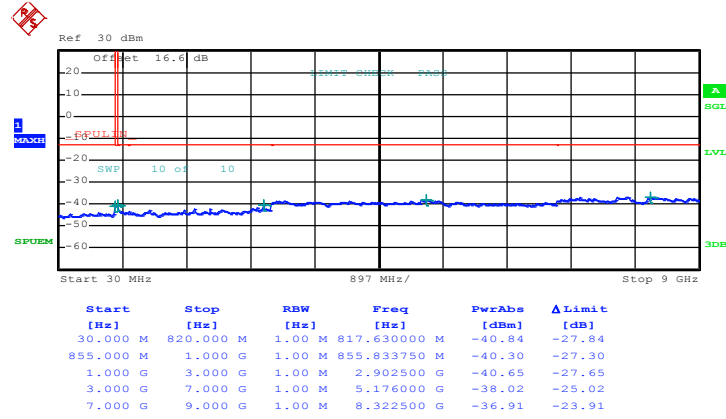

Date: 16.JUN.2015 17:59:37



<b>Band :</b>	CDMA2000 BC0	<b>Channel :</b>	CH777
<b>Test Mode :</b>	1xRTT_RC1+SO55 (QPSK)	<b>Frequency :</b>	848.31 MHz

Conducted Spurious Emission Plot between 30MHz ~ 9GHz

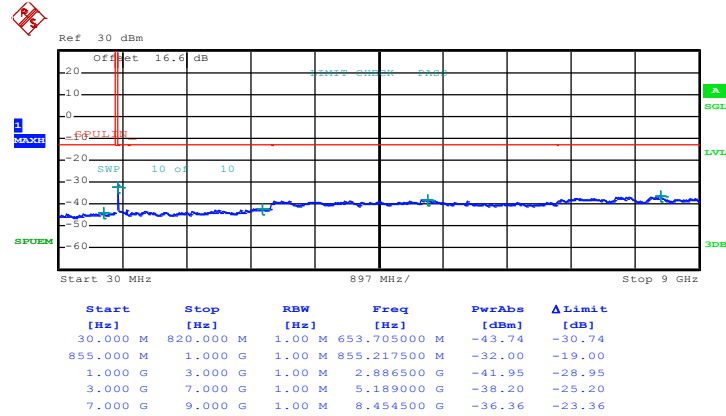

Date: 16.JUN.2015 18:00:05



<b>Band :</b>	CDMA2000 BC0	<b>Channel :</b>	CH1013
<b>Test Mode :</b>	1xEV-DO Rev. 0_RTAP 153.6K (QPSK)	<b>Frequency :</b>	824.7 MHz

Conducted Spurious Emission Plot between 30MHz ~ 9GHz

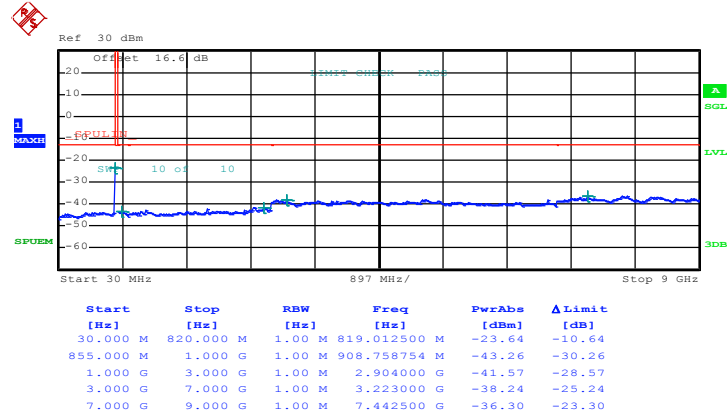

Date: 16.JUN.2015 18:28:57



<b>Band :</b>	CDMA2000 BC0	<b>Channel :</b>	CH384
<b>Test Mode :</b>	1xEV-DO Rev. 0_RTAP 153.6K (QPSK)	<b>Frequency :</b>	836.52 MHz

Conducted Spurious Emission Plot between 30MHz ~ 9GHz

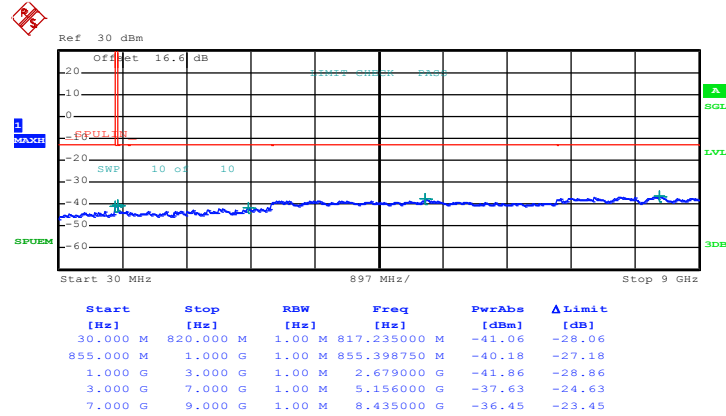

Date: 16.JUN.2015 18:29:22



<b>Band :</b>	CDMA2000 BC0	<b>Channel :</b>	CH777
<b>Test Mode :</b>	1xEV-DO Rev. 0_RTAP 153.6K (QPSK)	<b>Frequency :</b>	848.31 MHz

Conducted Spurious Emission Plot between 30MHz ~ 9GHz

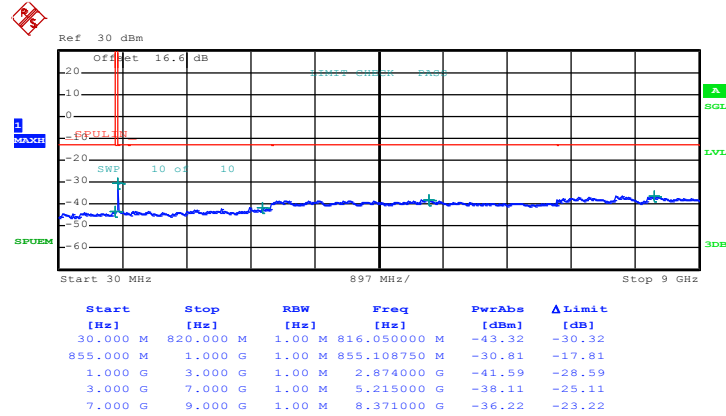

Date: 16.JUN.2015 18:29:47



<b>Band :</b>	CDMA2000 BC1	<b>Channel :</b>	CH25
<b>Test Mode :</b>	1xRTT_RC1+SO55 (QPSK)	<b>Frequency :</b>	1851.25 MHz

Conducted Spurious Emission Plot between 30MHz ~ 19.1GHz

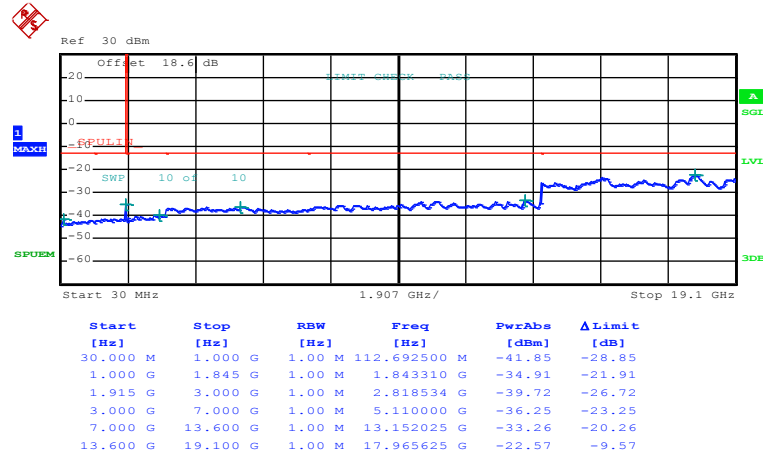

Date: 16.JUN.2015 18:44:54



<b>Band :</b>	CDMA2000 BC1	<b>Channel :</b>	CH600
<b>Test Mode :</b>	1xRTT_RC1+SO55 (QPSK)	<b>Frequency :</b>	1880.0 MHz

**Conducted Spurious Emission Plot between 30MHz ~ 19.1GHz**

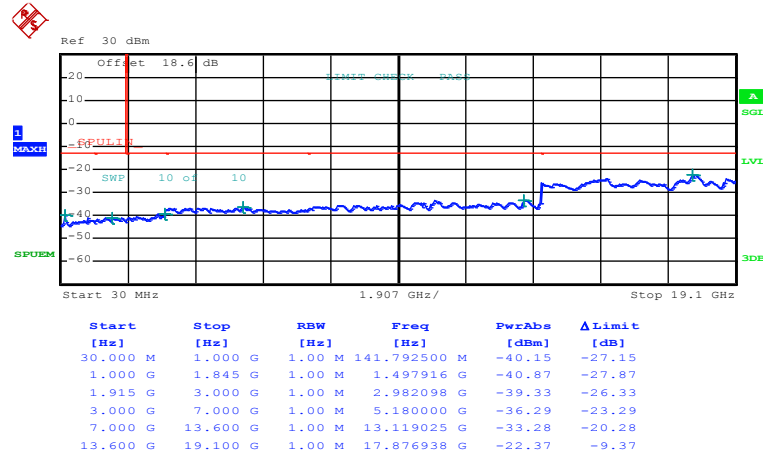

Date: 16.JUN.2015 18:45:22



<b>Band :</b>	CDMA2000 BC1	<b>Channel :</b>	CH1175
<b>Test Mode :</b>	1xRTT_RC1+SO55 (QPSK)	<b>Frequency :</b>	1908.75 MHz

**Conducted Spurious Emission Plot between 30MHz ~ 19.1GHz**

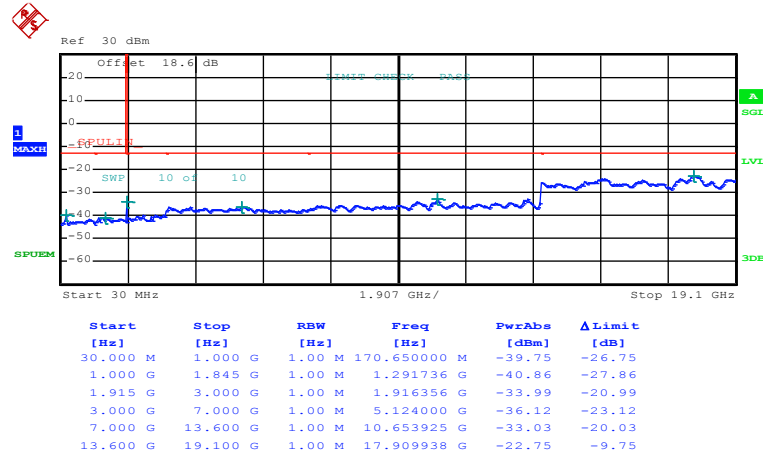

Date: 16.JUN.2015 18:45:53



<b>Band :</b>	CDMA2000 BC1	<b>Channel :</b>	CH25
<b>Test Mode :</b>	1xEV-DO Rev. 0_RTAP 153.6K (QPSK)	<b>Frequency :</b>	1851.25 MHz

**Conducted Spurious Emission Plot between 30MHz ~ 19.1GHz**

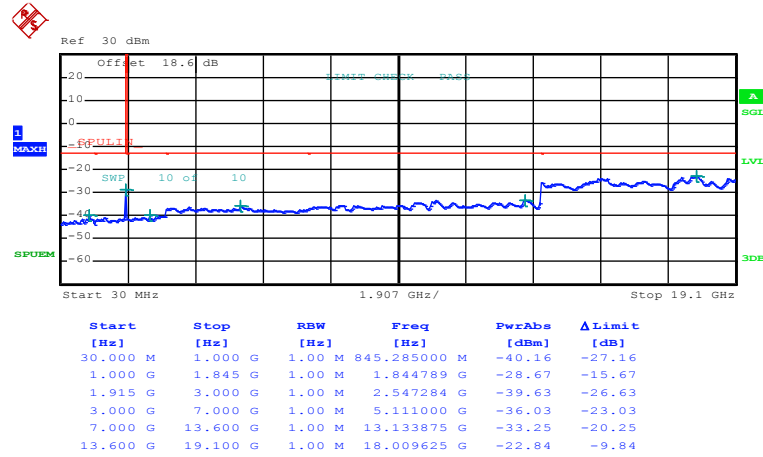

Date: 16.JUN.2015 19:02:44



<b>Band :</b>	CDMA2000 BC1	<b>Channel :</b>	CH600
<b>Test Mode :</b>	1xEV-DO Rev. 0_RTAP 153.6K (QPSK)	<b>Frequency :</b>	1880.0 MHz

Conducted Spurious Emission Plot between 30MHz ~ 19.1GHz

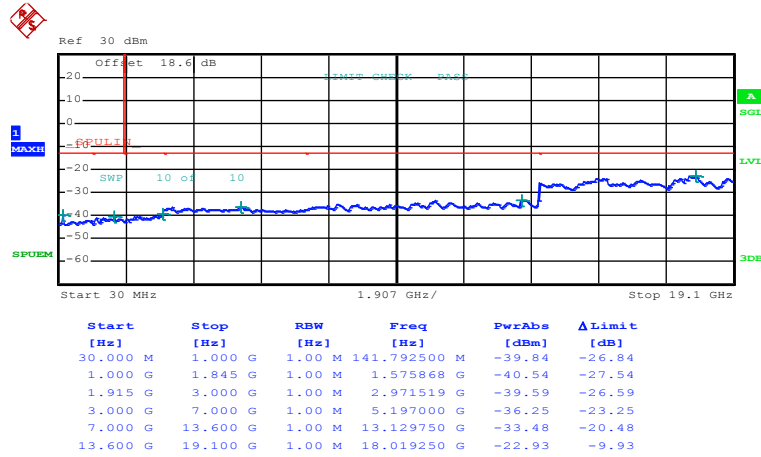

Date: 16.JUN.2015 19:03:11



<b>Band :</b>	CDMA2000 BC1	<b>Channel :</b>	CH1175
<b>Test Mode :</b>	1xEV-DO Rev. 0_RTAP 153.6K (QPSK)	<b>Frequency :</b>	1908.75 MHz

Conducted Spurious Emission Plot between 30MHz ~ 19.1GHz

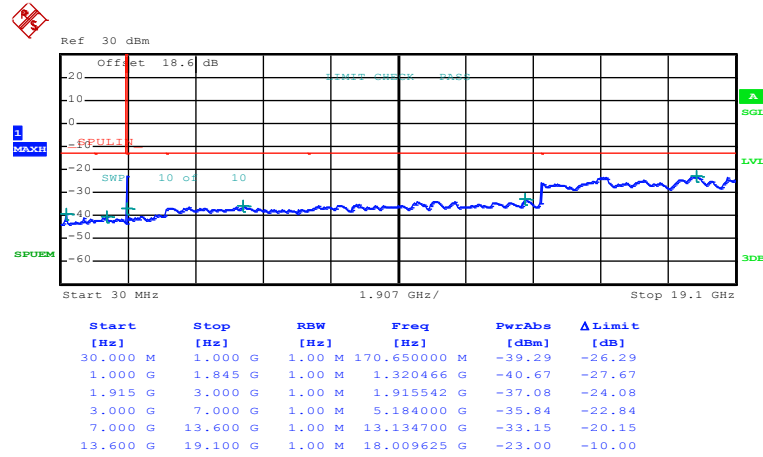

Date: 16.JUN.2015 19:03:43



### 3.7 Field Strength of Spurious Radiation Measurement

#### 3.7.1 Description of Field Strength of Spurious Radiated Measurement

The power of any emission outside of the authorized operating frequency ranges must be attenuated below the transmitter power (P) by a factor of at least  $43 + 10 \log (P)$  dB. The spectrum is scanned from 30 MHz up to a frequency including its 10th harmonic.

#### 3.7.2 Measuring Instruments

The measuring equipment is listed in the section 4 of this test report.

#### 3.7.3 Test Procedures

1. The testing follows FCC KDB 971168 v02r02 Section 5.8 and ANSI / TIA-603-C-2004 Section 2.2.12.
2. The EUT was placed on a rotatable wooden table 0.8 meters above the ground.
3. The EUT was set 3 meters from the receiving antenna, which was mounted on the antenna tower.
4. The table was rotated 360 degrees to determine the position of the highest spurious emission.
5. The height of the receiving antenna is varied between one meter and four meters to search for the maximum spurious emission for both horizontal and vertical polarizations.
6. Make the measurement with the spectrum analyzer's RBW = 1MHz, VBW = 3MHz, taking record of maximum spurious emission.
7. A horn antenna was substituted in place of the EUT and was driven by a signal generator.
8. Tune the output power of signal generator to the same emission level with EUT maximum spurious emission.
9. Taking the record of output power at antenna port.
10. Repeat step 7 to step 8 for another polarization.
11.  $EIRP \text{ (dBm)} = S.G. \text{ Power} - Tx \text{ Cable Loss} + Tx \text{ Antenna Gain}$
12.  $ERP \text{ (dBm)} = EIRP - 2.15$
13. The RF fundamental frequency should be excluded against the limit line in the operating frequency band.
14. The limit line is derived from  $43 + 10\log(P)$  dB below the transmitter power P(Watts)  
=  $P(W) - [43 + 10\log(P)] \text{ (dB)}$   
=  $[30 + 10\log(P)] \text{ (dBm)} - [43 + 10\log(P)] \text{ (dB)}$   
= -13dBm.

### 3.7.4 Test Setup

For radiated emissions from 30MHz to 1GHz

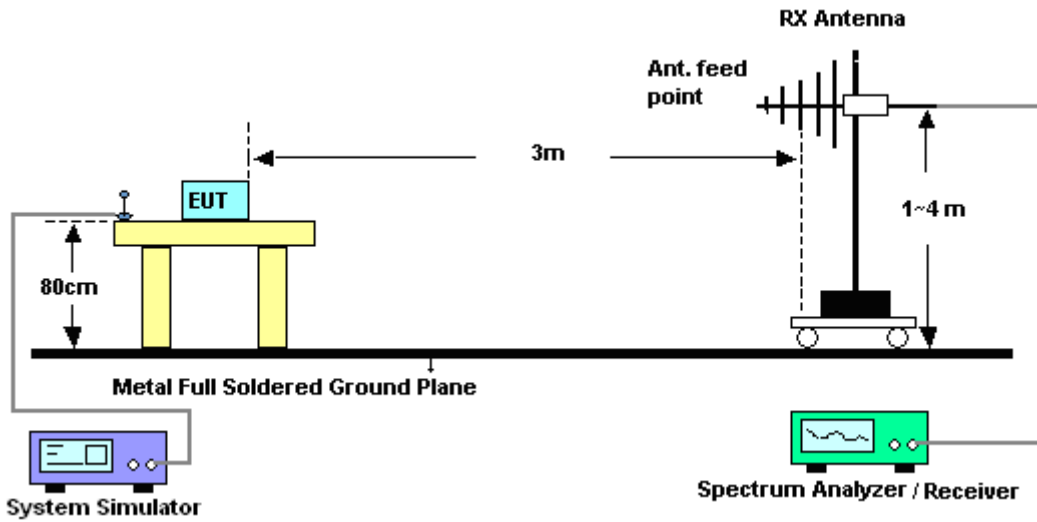

For radiated emissions above 1GHz

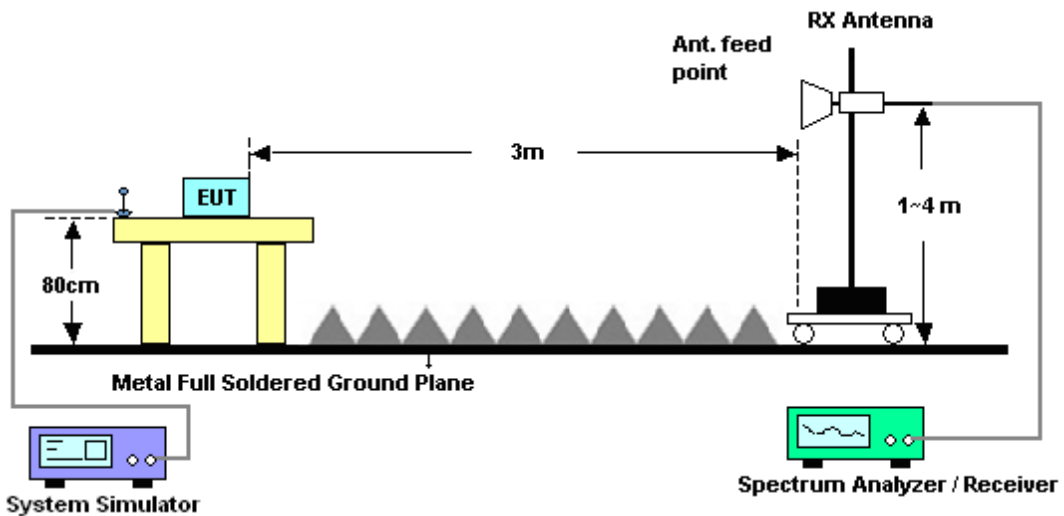



### 3.7.5 Test Result of Field Strength of Spurious Radiated

<EUT with WPC Charger>

<Low Channel>

<b>Band :</b>	GSM850					<b>Temperature :</b>	23~24°C		
<b>Test Mode :</b>	GPRS class 8 Link (GMSK)					<b>Relative Humidity :</b>	46~48%		
<b>Test Engineer :</b>	Jesse Wang and Derreck Chen					<b>Polarization :</b>	Horizontal		
<b>Remark :</b>	Spurious emissions within 30-1000MHz were found more than 20dB below limit line.								
Frequency ( MHz )	ERP ( dBm )	Limit ( dBm )	Over Limit ( dB )	SPA Reading ( dBm )	S.G. Power ( dBm )	TX Cable loss ( dB )	TX Antenna Gain ( dBi )	Polarization ( H/V )	Result
1648	-55.45	-13	-42.45	-59.77	-57.21	0.98	4.89	H	Pass
2472	-59.35	-13	-46.35	-68.07	-61.23	1.28	5.32	H	Pass
3296	-62.06	-13	-49.06	-74.09	-65.47	1.54	7.10	H	Pass

<b>Band :</b>	GSM850					<b>Temperature :</b>	23~24°C		
<b>Test Mode :</b>	GPRS class 8 Link (GMSK)					<b>Relative Humidity :</b>	46~48%		
<b>Test Engineer :</b>	Jesse Wang and Derreck Chen					<b>Polarization :</b>	Vertical		
<b>Remark :</b>	Spurious emissions within 30-1000MHz were found more than 20dB below limit line.								
Frequency ( MHz )	ERP ( dBm )	Limit ( dBm )	Over Limit ( dB )	SPA Reading ( dBm )	S.G. Power ( dBm )	TX Cable loss ( dB )	TX Antenna Gain ( dBi )	Polarization ( H/V )	Result
1648	-56.76	-13	-43.76	-59.96	-58.52	0.98	4.89	V	Pass
2472	-62.34	-13	-49.34	-72.11	-64.22	1.28	5.32	V	Pass
3296	-64.98	-13	-51.98	-76.01	-68.39	1.54	7.10	V	Pass



<Middle Channel>

<b>Band :</b>	GSM850				<b>Temperature :</b>	23~24°C			
<b>Test Mode :</b>	GPRS class 8 Link (GMSK)				<b>Relative Humidity :</b>	46~48%			
<b>Test Engineer :</b>	Jesse Wang and Derreck Chen				<b>Polarization :</b>	Horizontal			
<b>Remark :</b>	Spurious emissions within 30-1000MHz were found more than 20dB below limit line.								
Frequency ( MHz )	ERP ( dBm )	Limit ( dBm )	Over Limit ( dB )	SPA Reading ( dBm )	S.G. Power ( dBm )	TX Cable loss ( dB )	TX Antenna Gain ( dBi )	Polarization ( H/V )	Result
1672	-46.84	-13	-33.84	-51.11	-48.52	0.99	4.82	H	Pass
2512	-57.35	-13	-44.35	-65.98	-59.32	1.29	5.41	H	Pass
3344	-64.24	-13	-51.24	-78.89	-67.85	1.56	7.31	H	Pass

<b>Band :</b>	GSM850				<b>Temperature :</b>	23~24°C			
<b>Test Mode :</b>	GPRS class 8 Link (GMSK)				<b>Relative Humidity :</b>	46~48%			
<b>Test Engineer :</b>	Jesse Wang and Derreck Chen				<b>Polarization :</b>	Vertical			
<b>Remark :</b>	Spurious emissions within 30-1000MHz were found more than 20dB below limit line.								
Frequency ( MHz )	ERP ( dBm )	Limit ( dBm )	Over Limit ( dB )	SPA Reading ( dBm )	S.G. Power ( dBm )	TX Cable loss ( dB )	TX Antenna Gain ( dBi )	Polarization ( H/V )	Result
1672	-51.18	-13	-38.18	-53.55	-52.86	0.99	4.82	V	Pass
2512	-59.61	-13	-46.61	-69.72	-61.58	1.29	5.41	V	Pass
3344	-65.13	-13	-52.13	-76.07	-68.74	1.56	7.31	V	Pass



<High Channel>

<b>Band :</b>	GSM850		<b>Temperature :</b>	23~24°C					
<b>Test Mode :</b>	GPRS class 8 Link (GMSK)		<b>Relative Humidity :</b>	46~48%					
<b>Test Engineer :</b>	Jesse Wang and Derreck Chen		<b>Polarization :</b>	Horizontal					
<b>Remark :</b>	Spurious emissions within 30-1000MHz were found more than 20dB below limit line.								
Frequency ( MHz )	ERP ( dBm )	Limit ( dBm )	Over Limit ( dB )	SPA Reading ( dBm )	S.G. Power ( dBm )	TX Cable loss ( dB )	TX Antenna Gain ( dBi )	Polarization ( H/V )	Result
1696	-45.99	-13	-32.99	-49.94	-47.59	1.00	4.75	H	Pass
2546	-55.34	-13	-42.34	-64.81	-57.32	1.31	5.44	H	Pass
3395	-63.87	-13	-50.87	-75.88	-67.69	1.57	7.54	H	Pass

<b>Band :</b>	GSM850		<b>Temperature :</b>	23~24°C					
<b>Test Mode :</b>	GPRS class 8 Link (GMSK)		<b>Relative Humidity :</b>	46~48%					
<b>Test Engineer :</b>	Jesse Wang and Derreck Chen		<b>Polarization :</b>	Vertical					
<b>Remark :</b>	Spurious emissions within 30-1000MHz were found more than 20dB below limit line.								
Frequency ( MHz )	ERP ( dBm )	Limit ( dBm )	Over Limit ( dB )	SPA Reading ( dBm )	S.G. Power ( dBm )	TX Cable loss ( dB )	TX Antenna Gain ( dBi )	Polarization ( H/V )	Result
1696	-43.72	-13	-30.72	-46.92	-45.32	1.00	4.75	V	Pass
2546	-59.30	-13	-46.30	-68.84	-61.28	1.31	5.44	V	Pass
3395	-64.69	-13	-51.69	-75.73	-68.51	1.57	7.54	V	Pass



<Low Channel>

<b>Band :</b>	GSM850				<b>Temperature :</b>	23~24°C			
<b>Test Mode :</b>	EDGE class 8 Link (8PSK)				<b>Relative Humidity :</b>	46~48%			
<b>Test Engineer :</b>	Jesse Wang and Derreck Chen				<b>Polarization :</b>	Horizontal			
<b>Remark :</b>	Spurious emissions within 30-1000MHz were found more than 20dB below limit line.								
Frequency ( MHz )	ERP ( dBm )	Limit ( dBm )	Over Limit ( dB )	SPA Reading ( dBm )	S.G. Power ( dBm )	TX Cable loss ( dB )	TX Antenna Gain ( dBi )	Polarization ( H/V )	Result
1648	-66.56	-13	-53.56	-70.92	-68.32	0.98	4.89	H	Pass
2472	-66.00	-13	-53.00	-74.79	-67.88	1.28	5.32	H	Pass
3296	-64.51	-13	-51.51	-76.32	-67.92	1.54	7.10	H	Pass

<b>Band :</b>	GSM850				<b>Temperature :</b>	23~24°C			
<b>Test Mode :</b>	EDGE class 8 Link (8PSK)				<b>Relative Humidity :</b>	46~48%			
<b>Test Engineer :</b>	Jesse Wang and Derreck Chen				<b>Polarization :</b>	Vertical			
<b>Remark :</b>	Spurious emissions within 30-1000MHz were found more than 20dB below limit line.								
Frequency ( MHz )	ERP ( dBm )	Limit ( dBm )	Over Limit ( dB )	SPA Reading ( dBm )	S.G. Power ( dBm )	TX Cable loss ( dB )	TX Antenna Gain ( dBi )	Polarization ( H/V )	Result
1648	-67.93	-13	-54.93	-70.48	-69.69	0.98	4.89	V	Pass
2472	-65.26	-13	-52.26	-75.33	-67.14	1.28	5.32	V	Pass
3296	-65.17	-13	-52.17	-75.94	-68.58	1.54	7.10	V	Pass



<Middle Channel>

<b>Band :</b>	GSM850				<b>Temperature :</b>	23~24°C			
<b>Test Mode :</b>	EDGE class 8 Link (8PSK)				<b>Relative Humidity :</b>	46~48%			
<b>Test Engineer :</b>	Jesse Wang and Derreck Chen				<b>Polarization :</b>	Horizontal			
<b>Remark :</b>	Spurious emissions within 30-1000MHz were found more than 20dB below limit line.								
Frequency ( MHz )	ERP ( dBm )	Limit ( dBm )	Over Limit ( dB )	SPA Reading ( dBm )	S.G. Power ( dBm )	TX Cable loss ( dB )	TX Antenna Gain ( dBi )	Polarization ( H/V )	Result
1672	-63.17	-13	-50.17	-67.57	-64.85	0.99	4.82	H	Pass
2509	-66.07	-13	-53.07	-75.24	-68.03	1.29	5.41	H	Pass
3345	-63.97	-13	-50.97	-76.1	-67.58	1.56	7.32	H	Pass

<b>Band :</b>	GSM850				<b>Temperature :</b>	23~24°C			
<b>Test Mode :</b>	EDGE class 8 Link (8PSK)				<b>Relative Humidity :</b>	46~48%			
<b>Test Engineer :</b>	Jesse Wang and Derreck Chen				<b>Polarization :</b>	Vertical			
<b>Remark :</b>	Spurious emissions within 30-1000MHz were found more than 20dB below limit line.								
Frequency ( MHz )	ERP ( dBm )	Limit ( dBm )	Over Limit ( dB )	SPA Reading ( dBm )	S.G. Power ( dBm )	TX Cable loss ( dB )	TX Antenna Gain ( dBi )	Polarization ( H/V )	Result
1672	-65.64	-13	-52.64	-67.68	-67.32	0.99	4.82	V	Pass
2509	-65.28	-13	-52.28	-75.19	-67.24	1.29	5.41	V	Pass
3345	-64.75	-13	-51.75	-76.01	-68.36	1.56	7.32	V	Pass



<High Channel>

<b>Band :</b>	GSM850				<b>Temperature :</b>	23~24°C			
<b>Test Mode :</b>	EDGE class 8 Link (8PSK)				<b>Relative Humidity :</b>	46~48%			
<b>Test Engineer :</b>	Jesse Wang and Derreck Chen				<b>Polarization :</b>	Horizontal			
<b>Remark :</b>	Spurious emissions within 30-1000MHz were found more than 20dB below limit line.								
Frequency ( MHz )	ERP ( dBm )	Limit ( dBm )	Over Limit ( dB )	SPA Reading ( dBm )	S.G. Power ( dBm )	TX Cable loss ( dB )	TX Antenna Gain ( dBi )	Polarization ( H/V )	Result
1696	-59.82	-13	-46.82	-64.14	-61.42	1.00	4.75	H	Pass
2546	-66.05	-13	-53.05	-74.93	-68.03	1.31	5.44	H	Pass
3395	-64.21	-13	-51.21	-76.01	-68.03	1.57	7.54	H	Pass

<b>Band :</b>	GSM850				<b>Temperature :</b>	23~24°C			
<b>Test Mode :</b>	EDGE class 8 Link (8PSK)				<b>Relative Humidity :</b>	46~48%			
<b>Test Engineer :</b>	Jesse Wang and Derreck Chen				<b>Polarization :</b>	Vertical			
<b>Remark :</b>	Spurious emissions within 30-1000MHz were found more than 20dB below limit line.								
Frequency ( MHz )	ERP ( dBm )	Limit ( dBm )	Over Limit ( dB )	SPA Reading ( dBm )	S.G. Power ( dBm )	TX Cable loss ( dB )	TX Antenna Gain ( dBi )	Polarization ( H/V )	Result
1696	-61.98	-13	-48.98	-65.29	-63.58	1.00	4.75	V	Pass
2546	-65.79	-13	-52.79	-75.15	-69.92	1.31	5.44	V	Pass
3395	-65.31	-13	-52.31	-76.31	-71.28	1.57	7.54	V	Pass



<Low Channel>

<b>Band :</b>	GSM1900				<b>Temperature :</b>	23~24°C			
<b>Test Mode :</b>	GPRS class 8 Link (GMSK)				<b>Relative Humidity :</b>	46~48%			
<b>Test Engineer :</b>	Jesse Wang and Derreck Chen				<b>Polarization :</b>	Horizontal			
<b>Remark :</b>	Spurious emissions within 30-1000MHz were found more than 20dB below limit line.								
Frequency ( MHz )	EIRP ( dBm )	Limit ( dBm )	Over Limit ( dB )	SPA Reading ( dBm )	S.G. Power ( dBm )	TX Cable loss ( dB )	TX Antenna Gain ( dBi )	Polarization ( H/V )	Result
3700	-35.02	-13	-22.02	-49.46	-41.59	1.67	8.24	H	Pass
5548	-51.25	-13	-38.25	-70.69	-58.32	2.65	9.72	H	Pass
7403	-51.29	-13	-38.29	-75.83	-60.44	2.46	11.61	H	Pass

<b>Band :</b>	GSM1900				<b>Temperature :</b>	23~24°C			
<b>Test Mode :</b>	GPRS class 8 Link (GMSK)				<b>Relative Humidity :</b>	46~48%			
<b>Test Engineer :</b>	Jesse Wang and Derreck Chen				<b>Polarization :</b>	Vertical			
<b>Remark :</b>	Spurious emissions within 30-1000MHz were found more than 20dB below limit line.								
Frequency ( MHz )	EIRP ( dBm )	Limit ( dBm )	Over Limit ( dB )	SPA Reading ( dBm )	S.G. Power ( dBm )	TX Cable loss ( dB )	TX Antenna Gain ( dBi )	Polarization ( H/V )	Result
3700	-34.78	-13	-21.78	-49	-41.35	1.67	8.24	V	Pass
5548	-49.62	-13	-36.62	-67.17	-56.69	2.65	9.72	V	Pass
7403	-54.33	-13	-41.33	-77.75	-63.48	2.46	11.61	V	Pass



<Middle Channel>

<b>Band :</b>	GSM1900				<b>Temperature :</b>	23~24°C			
<b>Test Mode :</b>	GPRS class 8 Link (GMSK)				<b>Relative Humidity :</b>	46~48%			
<b>Test Engineer :</b>	Jesse Wang and Derreck Chen				<b>Polarization :</b>	Horizontal			
<b>Remark :</b>	Spurious emissions within 30-1000MHz were found more than 20dB below limit line.								
Frequency ( MHz )	EIRP ( dBm )	Limit ( dBm )	Over Limit ( dB )	SPA Reading ( dBm )	S.G. Power ( dBm )	TX Cable loss ( dB )	TX Antenna Gain ( dBi )	Polarization ( H/V )	Result
3763	-36.35	-13	-23.35	-50.69	-42.98	1.69	8.32	H	Pass
5639	-45.04	-13	-32.04	-64.3	-52.09	2.71	9.76	H	Pass
7522	-52.59	-13	-39.59	-76.96	-61.98	2.42	11.81	H	Pass

<b>Band :</b>	GSM1900				<b>Temperature :</b>	23~24°C			
<b>Test Mode :</b>	GPRS class 8 Link (GMSK)				<b>Relative Humidity :</b>	46~48%			
<b>Test Engineer :</b>	Jesse Wang and Derreck Chen				<b>Polarization :</b>	Vertical			
<b>Remark :</b>	Spurious emissions within 30-1000MHz were found more than 20dB below limit line.								
Frequency ( MHz )	EIRP ( dBm )	Limit ( dBm )	Over Limit ( dB )	SPA Reading ( dBm )	S.G. Power ( dBm )	TX Cable loss ( dB )	TX Antenna Gain ( dBi )	Polarization ( H/V )	Result
3763	-32.96	-13	-19.96	-47.07	-39.59	1.69	8.32	V	Pass
5639	-43.07	-13	-30.07	-61.29	-50.12	2.71	9.76	V	Pass
7522	-54.22	-13	-41.22	-77.74	-63.61	2.42	11.81	V	Pass



<High Channel>

<b>Band :</b>	GSM1900				<b>Temperature :</b>	23~24°C			
<b>Test Mode :</b>	GPRS class 8 Link (GMSK)				<b>Relative Humidity :</b>	46~48%			
<b>Test Engineer :</b>	Jesse Wang and Derreck Chen				<b>Polarization :</b>	Horizontal			
<b>Remark :</b>	Spurious emissions within 30-1000MHz were found more than 20dB below limit line.								
Frequency ( MHz )	EIRP ( dBm )	Limit ( dBm )	Over Limit ( dB )	SPA Reading ( dBm )	S.G. Power ( dBm )	TX Cable loss ( dB )	TX Antenna Gain ( dBi )	Polarization ( H/V )	Result
3819	-28.68	-13	-15.68	-43.14	-35.36	1.70	8.38	H	Pass
5730	-43.53	-13	-30.53	-63.06	-50.56	2.76	9.79	H	Pass
7639	-53.53	-13	-40.53	-77.72	-63.03	2.38	11.88	H	Pass

<b>Band :</b>	GSM1900				<b>Temperature :</b>	23~24°C			
<b>Test Mode :</b>	GPRS class 8 Link (GMSK)				<b>Relative Humidity :</b>	46~48%			
<b>Test Engineer :</b>	Jesse Wang and Derreck Chen				<b>Polarization :</b>	Vertical			
<b>Remark :</b>	Spurious emissions within 30-1000MHz were found more than 20dB below limit line.								
Frequency ( MHz )	EIRP ( dBm )	Limit ( dBm )	Over Limit ( dB )	SPA Reading ( dBm )	S.G. Power ( dBm )	TX Cable loss ( dB )	TX Antenna Gain ( dBi )	Polarization ( H/V )	Result
3819	-30.19	-13	-17.19	-44	-36.87	1.70	8.38	V	Pass
5730	-50.87	-13	-37.87	-69.88	-57.9	2.76	9.79	V	Pass
7639	-51.08	-13	-38.08	-74.5	-60.58	2.38	11.88	V	Pass



<Low Channel>

<b>Band :</b>	GSM1900				<b>Temperature :</b>	23~24°C			
<b>Test Mode :</b>	EDGE class 8 Link (8PSK)				<b>Relative Humidity :</b>	46~48%			
<b>Test Engineer :</b>	Jesse Wang and Derreck Chen				<b>Polarization :</b>	Horizontal			
<b>Remark :</b>	Spurious emissions within 30-1000MHz were found more than 20dB below limit line.								
Frequency ( MHz )	EIRP ( dBm )	Limit ( dBm )	Over Limit ( dB )	SPA Reading ( dBm )	S.G. Power ( dBm )	TX Cable loss ( dB )	TX Antenna Gain ( dBi )	Polarization ( H/V )	Result
3700	-44.52	-13	-31.52	-58.63	-51.09	1.67	8.24	H	Pass
5550	-57.89	-13	-44.89	-78.11	-64.96	2.65	9.72	H	Pass
7400	-53.18	-13	-40.18	-77.85	-62.32	2.46	11.60	H	Pass

<b>Band :</b>	GSM1900				<b>Temperature :</b>	23~24°C			
<b>Test Mode :</b>	EDGE class 8 Link (8PSK)				<b>Relative Humidity :</b>	46~48%			
<b>Test Engineer :</b>	Jesse Wang and Derreck Chen				<b>Polarization :</b>	Vertical			
<b>Remark :</b>	Spurious emissions within 30-1000MHz were found more than 20dB below limit line.								
Frequency ( MHz )	EIRP ( dBm )	Limit ( dBm )	Over Limit ( dB )	SPA Reading ( dBm )	S.G. Power ( dBm )	TX Cable loss ( dB )	TX Antenna Gain ( dBi )	Polarization ( H/V )	Result
3700	-41.75	-13	-28.75	-55.51	-48.32	1.67	8.24	V	Pass
5550	-53.40	-13	-40.40	-71.3	-60.47	2.65	9.72	V	Pass
7400	-53.44	-13	-40.44	-77.63	-62.58	2.46	11.60	V	Pass



<Middle Channel>

<b>Band :</b>	GSM1900	<b>Temperature :</b>	23~24°C						
<b>Test Mode :</b>	EDGE class 8 Link (8PSK)	<b>Relative Humidity :</b>	46~48%						
<b>Test Engineer :</b>	Jesse Wang and Derreck Chen	<b>Polarization :</b>	Horizontal						
<b>Remark :</b>	Spurious emissions within 30-1000MHz were found more than 20dB below limit line.								
Frequency ( MHz )	EIRP ( dBm )	Limit ( dBm )	Over Limit ( dB )	SPA Reading ( dBm )	S.G. Power ( dBm )	TX Cable loss ( dB )	TX Antenna Gain ( dBi )	Polarization ( H/V )	Result
3763	-43.30	-13	-30.30	-57.63	-49.93	1.69	8.32	H	Pass
5640	-58.31	-13	-45.31	-77.57	-65.36	2.71	9.76	H	Pass
7520	-53.19	-13	-40.19	-71.91	-62.58	2.42	11.81	H	Pass

<b>Band :</b>	GSM1900	<b>Temperature :</b>	23~24°C						
<b>Test Mode :</b>	EDGE class 8 Link (8PSK)	<b>Relative Humidity :</b>	46~48%						
<b>Test Engineer :</b>	Jesse Wang and Derreck Chen	<b>Polarization :</b>	Vertical						
<b>Remark :</b>	Spurious emissions within 30-1000MHz were found more than 20dB below limit line.								
Frequency ( MHz )	EIRP ( dBm )	Limit ( dBm )	Over Limit ( dB )	SPA Reading ( dBm )	S.G. Power ( dBm )	TX Cable loss ( dB )	TX Antenna Gain ( dBi )	Polarization ( H/V )	Result
3763	-39.89	-13	-26.89	-55.26	-46.52	1.69	8.32	V	Pass
5640	-54.44	-13	-41.44	-72.3	-61.49	2.71	9.76	V	Pass
7520	-54.19	-13	-41.19	-77.47	-63.58	2.42	11.81	V	Pass



<High Channel>

<b>Band :</b>	GSM1900	<b>Temperature :</b>	23~24°C						
<b>Test Mode :</b>	EDGE class 8 Link (8PSK)	<b>Relative Humidity :</b>	46~48%						
<b>Test Engineer :</b>	Jesse Wang and Derreck Chen	<b>Polarization :</b>	Horizontal						
<b>Remark :</b>	Spurious emissions within 30-1000MHz were found more than 20dB below limit line.								
Frequency ( MHz )	EIRP ( dBm )	Limit ( dBm )	Over Limit ( dB )	SPA Reading ( dBm )	S.G. Power ( dBm )	TX Cable loss ( dB )	TX Antenna Gain ( dBi )	Polarization ( H/V )	Result
3819	-39.17	-13	-26.17	-53.65	-45.85	1.70	8.38	H	Pass
5729	-53.29	-13	-40.29	-72.83	-60.32	2.76	9.79	H	Pass
7639	-54.07	-13	-41.07	-78.13	-63.57	2.38	11.88	H	Pass

<b>Band :</b>	GSM1900	<b>Temperature :</b>	23~24°C						
<b>Test Mode :</b>	EDGE class 8 Link (8PSK)	<b>Relative Humidity :</b>	46~48%						
<b>Test Engineer :</b>	Jesse Wang and Derreck Chen	<b>Polarization :</b>	Vertical						
<b>Remark :</b>	Spurious emissions within 30-1000MHz were found more than 20dB below limit line.								
Frequency ( MHz )	EIRP ( dBm )	Limit ( dBm )	Over Limit ( dB )	SPA Reading ( dBm )	S.G. Power ( dBm )	TX Cable loss ( dB )	TX Antenna Gain ( dBi )	Polarization ( H/V )	Result
3819	-36.27	-13	-23.27	-51.08	-42.95	1.70	8.38	V	Pass
5729	-51.93	-13	-38.93	-70.06	-58.96	2.76	9.79	V	Pass
7639	-54.53	-13	-41.53	-78.08	-64.03	2.38	11.88	V	Pass



<Low Channel>

<b>Band :</b>	WCDMA Band V	<b>Temperature :</b>	23~24°C						
<b>Test Mode :</b>	RMC 12.2Kbps Link (QPSK)	<b>Relative Humidity :</b>	46~48%						
<b>Test Engineer :</b>	Jesse Wang and Derreck Chen	<b>Polarization :</b>	Horizontal						
<b>Remark :</b>	Spurious emissions within 30-1000MHz were found more than 20dB below limit line.								
Frequency ( MHz )	ERP ( dBm )	Limit ( dBm )	Over Limit ( dB )	SPA Reading ( dBm )	S.G. Power ( dBm )	TX Cable loss ( dB )	TX Antenna Gain ( dBi )	Polarization ( H/V )	Result
1656	-68.39	-13	-55.39	-72.37	-70.12	0.98	4.86	H	Pass
2479	-66.42	-13	-53.42	-75.21	-68.32	1.28	5.34	H	Pass
3305	-63.84	-13	-50.84	-75.66	-67.29	1.54	7.14	H	Pass

<b>Band :</b>	WCDMA Band V	<b>Temperature :</b>	23~24°C						
<b>Test Mode :</b>	RMC 12.2Kbps Link (QPSK)	<b>Relative Humidity :</b>	46~48%						
<b>Test Engineer :</b>	Jesse Wang and Derreck Chen	<b>Polarization :</b>	Vertical						
<b>Remark :</b>	Spurious emissions within 30-1000MHz were found more than 20dB below limit line.								
Frequency ( MHz )	ERP ( dBm )	Limit ( dBm )	Over Limit ( dB )	SPA Reading ( dBm )	S.G. Power ( dBm )	TX Cable loss ( dB )	TX Antenna Gain ( dBi )	Polarization ( H/V )	Result
1656	-70.36	-13	-57.36	-73.42	-72.09	0.98	4.86	V	Pass
2479	-65.69	-13	-52.69	-75.46	-67.59	1.28	5.34	V	Pass
3305	-64.74	-13	-51.74	-75.8	-68.19	1.54	7.14	V	Pass



<Middle Channel>

<b>Band :</b>	WCDMA Band V	<b>Temperature :</b>	23~24°C						
<b>Test Mode :</b>	RMC 12.2Kbps Link (QPSK)	<b>Relative Humidity :</b>	46~48%						
<b>Test Engineer :</b>	Jesse Wang and Derreck Chen	<b>Polarization :</b>	Horizontal						
<b>Remark :</b>	Spurious emissions within 30-1000MHz were found more than 20dB below limit line.								
Frequency ( MHz )	ERP ( dBm )	Limit ( dBm )	Over Limit ( dB )	SPA Reading ( dBm )	S.G. Power ( dBm )	TX Cable loss ( dB )	TX Antenna Gain ( dBi )	Polarization ( H/V )	Result
1672	-66.44	-13	-53.44	-70.7	-68.12	0.99	4.82	H	Pass
2509	-65.63	-13	-52.63	-74.48	-67.59	1.29	5.41	H	Pass
3345	-63.83	-13	-50.83	-75.76	-67.44	1.56	7.32	H	Pass

<b>Band :</b>	WCDMA Band V	<b>Temperature :</b>	23~24°C						
<b>Test Mode :</b>	RMC 12.2Kbps Link (QPSK)	<b>Relative Humidity :</b>	46~48%						
<b>Test Engineer :</b>	Jesse Wang and Derreck Chen	<b>Polarization :</b>	Vertical						
<b>Remark :</b>	Spurious emissions within 30-1000MHz were found more than 20dB below limit line.								
Frequency ( MHz )	ERP ( dBm )	Limit ( dBm )	Over Limit ( dB )	SPA Reading ( dBm )	S.G. Power ( dBm )	TX Cable loss ( dB )	TX Antenna Gain ( dBi )	Polarization ( H/V )	Result
1672	-69.10	-13	-56.10	-71.75	-70.78	0.99	4.82	V	Pass
2509	-65.00	-13	-52.00	-74.9	-66.96	1.29	5.41	V	Pass
3345	-65.02	-13	-52.02	-76.08	-68.63	1.56	7.32	V	Pass



<High Channel>

<b>Band :</b>	WCDMA Band V	<b>Temperature :</b>	23~24°C						
<b>Test Mode :</b>	RMC 12.2Kbps Link (QPSK)	<b>Relative Humidity :</b>	46~48%						
<b>Test Engineer :</b>	Jesse Wang and Derreck Chen	<b>Polarization :</b>	Horizontal						
<b>Remark :</b>	Spurious emissions within 30-1000MHz were found more than 20dB below limit line.								
Frequency ( MHz )	ERP ( dBm )	Limit ( dBm )	Over Limit ( dB )	SPA Reading ( dBm )	S.G. Power ( dBm )	TX Cable loss ( dB )	TX Antenna Gain ( dBi )	Polarization ( H/V )	Result
1696	-64.72	-13	-51.72	-68.86	-66.32	1.00	4.75	H	Pass
2539	-66.00	-13	-53.00	-75.18	-67.98	1.30	5.43	H	Pass
3386	-64.04	-13	-51.04	-76.09	-67.82	1.57	7.50	H	Pass

<b>Band :</b>	WCDMA Band V	<b>Temperature :</b>	23~24°C						
<b>Test Mode :</b>	RMC 12.2Kbps Link (QPSK)	<b>Relative Humidity :</b>	46~48%						
<b>Test Engineer :</b>	Jesse Wang and Derreck Chen	<b>Polarization :</b>	Vertical						
<b>Remark :</b>	Spurious emissions within 30-1000MHz were found more than 20dB below limit line.								
Frequency ( MHz )	ERP ( dBm )	Limit ( dBm )	Over Limit ( dB )	SPA Reading ( dBm )	S.G. Power ( dBm )	TX Cable loss ( dB )	TX Antenna Gain ( dBi )	Polarization ( H/V )	Result
1696	-66.72	-13	-53.72	-70.07	-68.32	1.00	4.75	V	Pass
2539	-64.74	-13	-51.74	-74.95	-66.72	1.30	5.43	V	Pass
3386	-64.99	-13	-51.99	-76.06	-68.77	1.57	7.50	V	Pass



<Low Channel>

<b>Band :</b>	WCDMA Band II	<b>Temperature :</b>	23~24°C						
<b>Test Mode :</b>	RMC 12.2Kbps Link (QPSK)	<b>Relative Humidity :</b>	46~48%						
<b>Test Engineer :</b>	Jesse Wang and Derreck Chen	<b>Polarization :</b>	Horizontal						
<b>Remark :</b>	Spurious emissions within 30-1000MHz were found more than 20dB below limit line.								
Frequency ( MHz )	EIRP ( dBm )	Limit ( dBm )	Over Limit ( dB )	SPA Reading ( dBm )	S.G. Power ( dBm )	TX Cable loss ( dB )	TX Antenna Gain ( dBi )	Polarization ( H/V )	Result
3707	-49.05	-13	-36.05	-63.4	-55.63	1.67	8.25	H	Pass
5557	-58.42	-13	-45.42	-78.48	-65.48	2.66	9.72	H	Pass
7409	-53.31	-13	-40.31	-77.83	-62.47	2.46	11.62	H	Pass

<b>Band :</b>	WCDMA Band II	<b>Temperature :</b>	23~24°C						
<b>Test Mode :</b>	RMC 12.2Kbps Link (QPSK)	<b>Relative Humidity :</b>	46~48%						
<b>Test Engineer :</b>	Jesse Wang and Derreck Chen	<b>Polarization :</b>	Vertical						
<b>Remark :</b>	Spurious emissions within 30-1000MHz were found more than 20dB below limit line.								
Frequency ( MHz )	EIRP ( dBm )	Limit ( dBm )	Over Limit ( dB )	SPA Reading ( dBm )	S.G. Power ( dBm )	TX Cable loss ( dB )	TX Antenna Gain ( dBi )	Polarization ( H/V )	Result
3707	-51.11	-13	-38.11	-64.96	-57.69	1.67	8.25	V	Pass
5557	-60.97	-13	-47.97	-78.62	-68.03	2.66	9.72	V	Pass
7409	-54.31	-13	-41.31	-77.81	-63.47	2.46	11.62	V	Pass



<Middle Channel>

<b>Band :</b>	WCDMA Band II	<b>Temperature :</b>	23~24°C						
<b>Test Mode :</b>	RMC 12.2Kbps Link (QPSK)	<b>Relative Humidity :</b>	46~48%						
<b>Test Engineer :</b>	Jesse Wang and Derreck Chen	<b>Polarization :</b>	Horizontal						
<b>Remark :</b>	Spurious emissions within 30-1000MHz were found more than 20dB below limit line.								
Frequency ( MHz )	EIRP ( dBm )	Limit ( dBm )	Over Limit ( dB )	SPA Reading ( dBm )	S.G. Power ( dBm )	TX Cable loss ( dB )	TX Antenna Gain ( dBi )	Polarization ( H/V )	Result
3760	-44.65	-13	-31.65	-59.1	-51.28	1.69	8.31	H	Pass
5640	-58.31	-13	-45.31	-77.47	-65.36	2.71	9.76	H	Pass
7520	-53.19	-13	-40.19	-77.98	-62.58	2.42	11.81	H	Pass

<b>Band :</b>	WCDMA Band II	<b>Temperature :</b>	23~24°C						
<b>Test Mode :</b>	RMC 12.2Kbps Link (QPSK)	<b>Relative Humidity :</b>	46~48%						
<b>Test Engineer :</b>	Jesse Wang and Derreck Chen	<b>Polarization :</b>	Vertical						
<b>Remark :</b>	Spurious emissions within 30-1000MHz were found more than 20dB below limit line.								
Frequency ( MHz )	EIRP ( dBm )	Limit ( dBm )	Over Limit ( dB )	SPA Reading ( dBm )	S.G. Power ( dBm )	TX Cable loss ( dB )	TX Antenna Gain ( dBi )	Polarization ( H/V )	Result
3760	-47.69	-13	-34.69	-61.97	-54.32	1.69	8.31	V	Pass
5640	-60.24	-13	-47.24	-77.89	-67.29	2.71	9.76	V	Pass
7520	-54.08	-13	-41.08	-77.88	-63.47	2.42	11.81	V	Pass



<High Channel>

<b>Band :</b>	WCDMA Band II	<b>Temperature :</b>	23~24°C						
<b>Test Mode :</b>	RMC 12.2Kbps Link (QPSK)	<b>Relative Humidity :</b>	46~48%						
<b>Test Engineer :</b>	Jesse Wang and Derreck Chen	<b>Polarization :</b>	Horizontal						
<b>Remark :</b>	Spurious emissions within 30-1000MHz were found more than 20dB below limit line.								
Frequency ( MHz )	EIRP ( dBm )	Limit ( dBm )	Over Limit ( dB )	SPA Reading ( dBm )	S.G. Power ( dBm )	TX Cable loss ( dB )	TX Antenna Gain ( dBi )	Polarization ( H/V )	Result
3812	-46.96	-13	-33.96	-61.56	-53.63	1.70	8.37	H	Pass
5722	-58.28	-13	-45.28	-78.33	-65.32	2.75	9.79	H	Pass
7630	-53.98	-13	-40.98	-78.01	-63.47	2.39	11.88	H	Pass

<b>Band :</b>	WCDMA Band II	<b>Temperature :</b>	23~24°C						
<b>Test Mode :</b>	RMC 12.2Kbps Link (QPSK)	<b>Relative Humidity :</b>	46~48%						
<b>Test Engineer :</b>	Jesse Wang and Derreck Chen	<b>Polarization :</b>	Vertical						
<b>Remark :</b>	Spurious emissions within 30-1000MHz were found more than 20dB below limit line.								
Frequency ( MHz )	EIRP ( dBm )	Limit ( dBm )	Over Limit ( dB )	SPA Reading ( dBm )	S.G. Power ( dBm )	TX Cable loss ( dB )	TX Antenna Gain ( dBi )	Polarization ( H/V )	Result
3812	-46.65	-13	-33.65	-60.47	-53.32	1.70	8.37	V	Pass
5722	-60.05	-13	-47.05	-78.16	-67.09	2.75	9.79	V	Pass
7630	-54.86	-13	-41.86	-78.02	-64.35	2.39	11.88	V	Pass



<Low Channel>

<b>Band :</b>	CDMA2000 BC0	<b>Temperature :</b>	23~24°C						
<b>Test Mode :</b>	1xRTT_RC1+SO55 (QPSK)	<b>Relative Humidity :</b>	46~48%						
<b>Test Engineer :</b>	Jesse Wang and Derreck Chen	<b>Polarization :</b>	Horizontal						
<b>Remark :</b>	Spurious emissions within 30-1000MHz were found more than 20dB below limit line.								
Frequency ( MHz )	ERP ( dBm )	Limit ( dBm )	Over Limit ( dB )	SPA Reading ( dBm )	S.G. Power ( dBm )	TX Cable loss ( dB )	TX Antenna Gain ( dBi )	Polarization ( H/V )	Result
1648	-67.36	-13	-54.36	-72.09	-69.12	0.98	4.89	H	Pass
2474	-65.42	-13	-52.42	-74.81	-67.31	1.28	5.32	H	Pass
3298	-61.94	-13	-48.94	-74.45	-65.36	1.54	7.11	H	Pass

<b>Band :</b>	CDMA2000 BC0	<b>Temperature :</b>	23~24°C						
<b>Test Mode :</b>	1xRTT_RC1+SO55 (QPSK)	<b>Relative Humidity :</b>	46~48%						
<b>Test Engineer :</b>	Jesse Wang and Derreck Chen	<b>Polarization :</b>	Vertical						
<b>Remark :</b>	Spurious emissions within 30-1000MHz were found more than 20dB below limit line.								
Frequency ( MHz )	ERP ( dBm )	Limit ( dBm )	Over Limit ( dB )	SPA Reading ( dBm )	S.G. Power ( dBm )	TX Cable loss ( dB )	TX Antenna Gain ( dBi )	Polarization ( H/V )	Result
1648	-70.12	-13	-57.12	-73.39	-71.88	0.98	4.89	V	Pass
2474	-64.57	-13	-51.57	-74.94	-66.46	1.28	5.32	V	Pass
3298	-64.04	-13	-51.04	-75.56	-67.46	1.54	7.11	V	Pass



<Middle Channel>

<b>Band :</b>	CDMA2000 BC0	<b>Temperature :</b>	23~24°C						
<b>Test Mode :</b>	1xRTT_RC1+SO55 (QPSK)	<b>Relative Humidity :</b>	46~48%						
<b>Test Engineer :</b>	Jesse Wang and Derreck Chen	<b>Polarization :</b>	Horizontal						
<b>Remark :</b>	Spurious emissions within 30-1000MHz were found more than 20dB below limit line.								
Frequency ( MHz )	ERP ( dBm )	Limit ( dBm )	Over Limit ( dB )	SPA Reading ( dBm )	S.G. Power ( dBm )	TX Cable loss ( dB )	TX Antenna Gain ( dBi )	Polarization ( H/V )	Result
1672	-69.14	-13	-56.14	-73.73	-70.82	0.99	4.82	H	Pass
2509	-65.20	-13	-52.20	-74.76	-67.16	1.29	5.41	H	Pass
3346	-62.45	-13	-49.45	-74.62	-66.07	1.56	7.32	H	Pass

<b>Band :</b>	CDMA2000 BC0	<b>Temperature :</b>	23~24°C						
<b>Test Mode :</b>	1xRTT_RC1+SO55 (QPSK)	<b>Relative Humidity :</b>	46~48%						
<b>Test Engineer :</b>	Jesse Wang and Derreck Chen	<b>Polarization :</b>	Vertical						
<b>Remark :</b>	Spurious emissions within 30-1000MHz were found more than 20dB below limit line.								
Frequency ( MHz )	ERP ( dBm )	Limit ( dBm )	Over Limit ( dB )	SPA Reading ( dBm )	S.G. Power ( dBm )	TX Cable loss ( dB )	TX Antenna Gain ( dBi )	Polarization ( H/V )	Result
1672	-68.74	-13	-55.74	-71.76	-70.42	0.99	4.82	V	Pass
2509	-64.55	-13	-51.55	-74.78	-66.51	1.29	5.41	V	Pass
3346	-64.04	-13	-51.04	-75.43	-67.66	1.56	7.32	V	Pass



<High Channel>

<b>Band :</b>	CDMA2000 BC0	<b>Temperature :</b>	23~24°C						
<b>Test Mode :</b>	1xRTT_RC1+SO55 (QPSK)	<b>Relative Humidity :</b>	46~48%						
<b>Test Engineer :</b>	Jesse Wang and Derreck Chen	<b>Polarization :</b>	Horizontal						
<b>Remark :</b>	Spurious emissions within 30-1000MHz were found more than 20dB below limit line.								
Frequency ( MHz )	ERP ( dBm )	Limit ( dBm )	Over Limit ( dB )	SPA Reading ( dBm )	S.G. Power ( dBm )	TX Cable loss ( dB )	TX Antenna Gain ( dBi )	Polarization ( H/V )	Result
1696	-64.26	-13	-51.26	-68.97	-65.86	1.00	4.75	H	Pass
2544	-64.99	-13	-51.99	-74.58	-66.97	1.30	5.44	H	Pass
3392	-62.74	-13	-49.74	-75.01	-66.54	1.57	7.52	H	Pass

<b>Band :</b>	CDMA2000 BC0	<b>Temperature :</b>	23~24°C						
<b>Test Mode :</b>	1xRTT_RC1+SO55 (QPSK)	<b>Relative Humidity :</b>	46~48%						
<b>Test Engineer :</b>	Jesse Wang and Derreck Chen	<b>Polarization :</b>	Vertical						
<b>Remark :</b>	Spurious emissions within 30-1000MHz were found more than 20dB below limit line.								
Frequency ( MHz )	ERP ( dBm )	Limit ( dBm )	Over Limit ( dB )	SPA Reading ( dBm )	S.G. Power ( dBm )	TX Cable loss ( dB )	TX Antenna Gain ( dBi )	Polarization ( H/V )	Result
1696	-65.85	-13	-52.85	-69.62	-67.45	1.00	4.75	V	Pass
2544	-64.48	-13	-51.48	-74.71	-66.46	1.30	5.44	V	Pass
3392	-64.16	-13	-51.16	-75.96	-67.96	1.57	7.52	V	Pass



<Low Channel>

<b>Band :</b>	CDMA2000 BC0						<b>Temperature :</b>	23~24°C	
<b>Test Mode :</b>	1xEV-DO Rev. 0_RTAP 153.6K (QPSK)						<b>Relative Humidity :</b>	46~48%	
<b>Test Engineer :</b>	Jesse Wang and Derreck Chen						<b>Polarization :</b>	Horizontal	
<b>Remark :</b>	Spurious emissions within 30-1000MHz were found more than 20dB below limit line.								
Frequency ( MHz )	ERP ( dBm )	Limit ( dBm )	Over Limit ( dB )	SPA Reading ( dBm )	S.G. Power ( dBm )	TX Cable loss ( dB )	TX Antenna Gain ( dBi )	Polarization ( H/V )	Result
1648	-68.60	-13	-55.60	-73.33	-70.36	0.98	4.89	H	Pass
2474	-65.33	-13	-52.33	-74.72	-67.22	1.28	5.32	H	Pass
3298	-49.56	-13	-36.56	-75.07	-52.98	1.54	7.11	H	Pass

<b>Band :</b>	CDMA2000 BC0						<b>Temperature :</b>	23~24°C	
<b>Test Mode :</b>	1xEV-DO Rev. 0_RTAP 153.6K (QPSK)						<b>Relative Humidity :</b>	46~48%	
<b>Test Engineer :</b>	Jesse Wang and Derreck Chen						<b>Polarization :</b>	Vertical	
<b>Remark :</b>	Spurious emissions within 30-1000MHz were found more than 20dB below limit line.								
Frequency ( MHz )	ERP ( dBm )	Limit ( dBm )	Over Limit ( dB )	SPA Reading ( dBm )	S.G. Power ( dBm )	TX Cable loss ( dB )	TX Antenna Gain ( dBi )	Polarization ( H/V )	Result
1648	-70.66	-13	-57.66	-73.93	-72.42	0.98	4.89	V	Pass
2474	-64.67	-13	-51.67	-75.04	-66.56	1.28	5.32	V	Pass
3298	-64.05	-13	-51.05	-75.57	-67.47	1.54	7.11	V	Pass



<Middle Channel>

<b>Band :</b>	CDMA2000 BC0	<b>Temperature :</b>	23~24°C						
<b>Test Mode :</b>	1xEV-DO Rev. 0_RTAP 153.6K (QPSK)	<b>Relative Humidity :</b>	46~48%						
<b>Test Engineer :</b>	Jesse Wang and Derreck Chen	<b>Polarization :</b>	Horizontal						
<b>Remark :</b>	Spurious emissions within 30-1000MHz were found more than 20dB below limit line.								
Frequency ( MHz )	ERP ( dBm )	Limit ( dBm )	Over Limit ( dB )	SPA Reading ( dBm )	S.G. Power ( dBm )	TX Cable loss ( dB )	TX Antenna Gain ( dBi )	Polarization ( H/V )	Result
1672	-67.74	-13	-54.74	-72.33	-69.42	0.99	4.82	H	Pass
2509	-65.08	-13	-52.08	-74.64	-67.04	1.29	5.41	H	Pass
3346	-62.02	-13	-49.02	-74.2	-65.64	1.56	7.32	H	Pass

<b>Band :</b>	CDMA2000 BC0	<b>Temperature :</b>	23~24°C						
<b>Test Mode :</b>	1xEV-DO Rev. 0_RTAP 153.6K (QPSK)	<b>Relative Humidity :</b>	46~48%						
<b>Test Engineer :</b>	Jesse Wang and Derreck Chen	<b>Polarization :</b>	Vertical						
<b>Remark :</b>	Spurious emissions within 30-1000MHz were found more than 20dB below limit line.								
Frequency ( MHz )	ERP ( dBm )	Limit ( dBm )	Over Limit ( dB )	SPA Reading ( dBm )	S.G. Power ( dBm )	TX Cable loss ( dB )	TX Antenna Gain ( dBi )	Polarization ( H/V )	Result
1672	-69.22	-13	-56.22	-72.24	-70.9	0.99	4.82	V	Pass
2509	-64.47	-13	-51.47	-74.7	-66.43	1.29	5.41	V	Pass
3346	-64.20	-13	-51.20	-75.6	-67.82	1.56	7.32	V	Pass



<High Channel>

<b>Band :</b>	CDMA2000 BC0	<b>Temperature :</b>	23~24°C						
<b>Test Mode :</b>	1xEV-DO Rev. 0_RTAP 153.6K (QPSK)	<b>Relative Humidity :</b>	46~48%						
<b>Test Engineer :</b>	Jesse Wang and Derreck Chen	<b>Polarization :</b>	Horizontal						
<b>Remark :</b>	Spurious emissions within 30-1000MHz were found more than 20dB below limit line.								
Frequency ( MHz )	ERP ( dBm )	Limit ( dBm )	Over Limit ( dB )	SPA Reading ( dBm )	S.G. Power ( dBm )	TX Cable loss ( dB )	TX Antenna Gain ( dBi )	Polarization ( H/V )	Result
1696	-66.02	-13	-53.02	-70.73	-67.62	1.00	4.75	H	Pass
2544	-65.27	-13	-52.27	-74.86	-67.25	1.30	5.44	H	Pass
3392	-63.50	-13	-50.50	-75.77	-67.3	1.57	7.52	H	Pass

<b>Band :</b>	CDMA2000 BC0	<b>Temperature :</b>	23~24°C						
<b>Test Mode :</b>	1xEV-DO Rev. 0_RTAP 153.6K (QPSK)	<b>Relative Humidity :</b>	46~48%						
<b>Test Engineer :</b>	Jesse Wang and Derreck Chen	<b>Polarization :</b>	Vertical						
<b>Remark :</b>	Spurious emissions within 30-1000MHz were found more than 20dB below limit line.								
Frequency ( MHz )	ERP ( dBm )	Limit ( dBm )	Over Limit ( dB )	SPA Reading ( dBm )	S.G. Power ( dBm )	TX Cable loss ( dB )	TX Antenna Gain ( dBi )	Polarization ( H/V )	Result
1696	-67.21	-13	-54.21	-70.98	-68.81	1.00	4.75	V	Pass
2544	-64.48	-13	-51.48	-74.71	-66.46	1.30	5.44	V	Pass
3392	-64.16	-13	-51.16	-75.96	-67.96	1.57	7.52	V	Pass



<Low Channel>

<b>Band :</b>	CDMA2000 BC1	<b>Temperature :</b>	23~24°C						
<b>Test Mode :</b>	1xRTT_RC1+SO55 (QPSK)	<b>Relative Humidity :</b>	46~48%						
<b>Test Engineer :</b>	Jesse Wang and Derreck Chen	<b>Polarization :</b>	Horizontal						
<b>Remark :</b>	Spurious emissions within 30-1000MHz were found more than 20dB below limit line.								
Frequency ( MHz )	EIRP ( dBm )	Limit ( dBm )	Over Limit ( dB )	SPA Reading ( dBm )	S.G. Power ( dBm )	TX Cable loss ( dB )	TX Antenna Gain ( dBi )	Polarization ( H/V )	Result
3700	-47.70	-13	-34.70	-62.19	-54.27	1.67	8.24	H	Pass
5553	-58.32	-13	-45.32	-78.45	-65.39	2.66	9.72	H	Pass
7405	-52.51	-13	-39.51	-77.98	-61.66	2.46	11.61	H	Pass

<b>Band :</b>	CDMA2000 BC1	<b>Temperature :</b>	23~24°C						
<b>Test Mode :</b>	1xRTT_RC1+SO55 (QPSK)	<b>Relative Humidity :</b>	46~48%						
<b>Test Engineer :</b>	Jesse Wang and Derreck Chen	<b>Polarization :</b>	Vertical						
<b>Remark :</b>	Spurious emissions within 30-1000MHz were found more than 20dB below limit line.								
Frequency ( MHz )	EIRP ( dBm )	Limit ( dBm )	Over Limit ( dB )	SPA Reading ( dBm )	S.G. Power ( dBm )	TX Cable loss ( dB )	TX Antenna Gain ( dBi )	Polarization ( H/V )	Result
3700	-45.73	-13	-32.73	-60.13	-52.3	1.67	8.24	V	Pass
5553	-59.81	-13	-46.81	-78.4	-66.88	2.66	9.72	V	Pass
7405	-53.67	-13	-40.67	-77.93	-62.82	2.46	11.61	V	Pass



<Middle Channel>

<b>Band :</b>	CDMA2000 BC1	<b>Temperature :</b>	23~24°C						
<b>Test Mode :</b>	1xRTT_RC1+SO55 (QPSK)	<b>Relative Humidity :</b>	46~48%						
<b>Test Engineer :</b>	Jesse Wang and Derreck Chen	<b>Polarization :</b>	Horizontal						
<b>Remark :</b>	Spurious emissions within 30-1000MHz were found more than 20dB below limit line.								
Frequency ( MHz )	EIRP ( dBm )	Limit ( dBm )	Over Limit ( dB )	SPA Reading ( dBm )	S.G. Power ( dBm )	TX Cable loss ( dB )	TX Antenna Gain ( dBi )	Polarization ( H/V )	Result
3763	-44.88	-13	-31.88	-59.58	-51.51	1.69	8.32	H	Pass
5640	-44.38	-13	-31.38	-77.28	-51.43	2.71	9.76	H	Pass
7520	-40.10	-13	-27.10	-78.09	-49.49	2.42	11.81	H	Pass

<b>Band :</b>	CDMA2000 BC1	<b>Temperature :</b>	23~24°C						
<b>Test Mode :</b>	1xRTT_RC1+SO55 (QPSK)	<b>Relative Humidity :</b>	46~48%						
<b>Test Engineer :</b>	Jesse Wang and Derreck Chen	<b>Polarization :</b>	Vertical						
<b>Remark :</b>	Spurious emissions within 30-1000MHz were found more than 20dB below limit line.								
Frequency ( MHz )	EIRP ( dBm )	Limit ( dBm )	Over Limit ( dB )	SPA Reading ( dBm )	S.G. Power ( dBm )	TX Cable loss ( dB )	TX Antenna Gain ( dBi )	Polarization ( H/V )	Result
3763	-40.01	-13	-27.01	-54.28	-46.64	1.69	8.32	V	Pass
5640	-58.16	-13	-45.16	-76.56	-65.21	2.71	9.76	V	Pass
7520	-53.69	-13	-40.69	-77.78	-63.08	2.42	11.81	V	Pass



<High Channel>

<b>Band :</b>	CDMA2000 BC1	<b>Temperature :</b>	23~24°C						
<b>Test Mode :</b>	1xRTT_RC1+SO55 (QPSK)	<b>Relative Humidity :</b>	46~48%						
<b>Test Engineer :</b>	Jesse Wang and Derreck Chen	<b>Polarization :</b>	Horizontal						
<b>Remark :</b>	Spurious emissions within 30-1000MHz were found more than 20dB below limit line.								
Frequency ( MHz )	EIRP ( dBm )	Limit ( dBm )	Over Limit ( dB )	SPA Reading ( dBm )	S.G. Power ( dBm )	TX Cable loss ( dB )	TX Antenna Gain ( dBi )	Polarization ( H/V )	Result
3819	-43.62	-13	-30.62	-58.4	-50.3	1.70	8.38	H	Pass
5726	-57.49	-13	-44.49	-77.64	-64.53	2.76	9.79	H	Pass
7635	-53.38	-13	-40.38	-78.07	-62.88	2.39	11.88	H	Pass

<b>Band :</b>	CDMA2000 BC1	<b>Temperature :</b>	23~24°C						
<b>Test Mode :</b>	1xRTT_RC1+SO55 (QPSK)	<b>Relative Humidity :</b>	46~48%						
<b>Test Engineer :</b>	Jesse Wang and Derreck Chen	<b>Polarization :</b>	Vertical						
<b>Remark :</b>	Spurious emissions within 30-1000MHz were found more than 20dB below limit line.								
Frequency ( MHz )	EIRP ( dBm )	Limit ( dBm )	Over Limit ( dB )	SPA Reading ( dBm )	S.G. Power ( dBm )	TX Cable loss ( dB )	TX Antenna Gain ( dBi )	Polarization ( H/V )	Result
3819	-42.97	-13	-29.97	-57.1	-49.65	1.70	8.38	V	Pass
5726	-57.64	-13	-44.64	-76.62	-64.68	2.76	9.79	V	Pass
7635	-53.74	-13	-40.74	-77.71	-63.24	2.39	11.88	V	Pass



<Low Channel>

<b>Band :</b>	CDMA2000 BC1	<b>Temperature :</b>	23~24°C						
<b>Test Mode :</b>	1xEV-DO Rev. 0_RTAP 153.6K (QPSK)	<b>Relative Humidity :</b>	46~48%						
<b>Test Engineer :</b>	Jesse Wang and Derreck Chen	<b>Polarization :</b>	Horizontal						
<b>Remark :</b>	Spurious emissions within 30-1000MHz were found more than 20dB below limit line.								
Frequency ( MHz )	EIRP ( dBm )	Limit ( dBm )	Over Limit ( dB )	SPA Reading ( dBm )	S.G. Power ( dBm )	TX Cable loss ( dB )	TX Antenna Gain ( dBi )	Polarization ( H/V )	Result
3700	-48.11	-13	-35.11	-62.6	-54.68	1.67	8.24	H	Pass
5553	-57.94	-13	-44.94	-78.07	-65.01	2.66	9.72	H	Pass
7405	-52.40	-13	-39.40	-77.87	-61.55	2.46	11.61	H	Pass

<b>Band :</b>	CDMA2000 BC1	<b>Temperature :</b>	23~24°C						
<b>Test Mode :</b>	1xEV-DO Rev. 0_RTAP 153.6K (QPSK)	<b>Relative Humidity :</b>	46~48%						
<b>Test Engineer :</b>	Jesse Wang and Derreck Chen	<b>Polarization :</b>	Vertical						
<b>Remark :</b>	Spurious emissions within 30-1000MHz were found more than 20dB below limit line.								
Frequency ( MHz )	EIRP ( dBm )	Limit ( dBm )	Over Limit ( dB )	SPA Reading ( dBm )	S.G. Power ( dBm )	TX Cable loss ( dB )	TX Antenna Gain ( dBi )	Polarization ( H/V )	Result
3700	-45.62	-13	-32.62	-60.02	-52.19	1.67	8.24	V	Pass
5553	-59.95	-13	-46.95	-78.54	-67.02	2.66	9.72	V	Pass
7405	-53.62	-13	-40.62	-77.88	-62.77	2.46	11.61	V	Pass



<Middle Channel>

<b>Band :</b>	CDMA2000 BC1	<b>Temperature :</b>	23~24°C						
<b>Test Mode :</b>	1xEV-DO Rev. 0_RTAP 153.6K (QPSK)	<b>Relative Humidity :</b>	46~48%						
<b>Test Engineer :</b>	Jesse Wang and Derreck Chen	<b>Polarization :</b>	Horizontal						
<b>Remark :</b>	Spurious emissions within 30-1000MHz were found more than 20dB below limit line.								
Frequency ( MHz )	EIRP ( dBm )	Limit ( dBm )	Over Limit ( dB )	SPA Reading ( dBm )	S.G. Power ( dBm )	TX Cable loss ( dB )	TX Antenna Gain ( dBi )	Polarization ( H/V )	Result
3760	-44.38	-13	-31.38	-59.09	-51.01	1.69	8.31	H	Pass
5640	-57.91	-13	-44.91	-77.81	-64.96	2.71	9.76	H	Pass
7520	-53.11	-13	-40.11	-78.11	-62.5	2.42	11.81	H	Pass

<b>Band :</b>	CDMA2000 BC1	<b>Temperature :</b>	23~24°C						
<b>Test Mode :</b>	1xEV-DO Rev. 0_RTAP 153.6K (QPSK)	<b>Relative Humidity :</b>	46~48%						
<b>Test Engineer :</b>	Jesse Wang and Derreck Chen	<b>Polarization :</b>	Vertical						
<b>Remark :</b>	Spurious emissions within 30-1000MHz were found more than 20dB below limit line.								
Frequency ( MHz )	EIRP ( dBm )	Limit ( dBm )	Over Limit ( dB )	SPA Reading ( dBm )	S.G. Power ( dBm )	TX Cable loss ( dB )	TX Antenna Gain ( dBi )	Polarization ( H/V )	Result
3760	-42.93	-13	-29.93	-57.32	-49.56	1.69	8.31	V	Pass
5640	-59.37	-13	-46.37	-77.77	-66.42	2.71	9.76	V	Pass
7520	-54.02	-13	-41.02	-78.12	-63.41	2.42	11.81	V	Pass



<High Channel>

<b>Band :</b>	CDMA2000 BC1	<b>Temperature :</b>	23~24°C						
<b>Test Mode :</b>	1xEV-DO Rev. 0_RTAP 153.6K (QPSK)	<b>Relative Humidity :</b>	46~48%						
<b>Test Engineer :</b>	Jesse Wang and Derreck Chen	<b>Polarization :</b>	Horizontal						
<b>Remark :</b>	Spurious emissions within 30-1000MHz were found more than 20dB below limit line.								
<b>Frequency ( MHz )</b>	<b>EIRP ( dBm )</b>	<b>Limit ( dBm )</b>	<b>Over Limit ( dB )</b>	<b>SPA Reading ( dBm )</b>	<b>S.G. Power ( dBm )</b>	<b>TX Cable loss ( dB )</b>	<b>TX Antenna Gain ( dBi )</b>	<b>Polarization ( H/V )</b>	<b>Result</b>
3819	-43.36	-13	-30.36	-58.15	-50.04	1.70	8.38	H	Pass
5726	-57.14	-13	-44.14	-77.3	-64.18	2.76	9.79	H	Pass
7635	-53.02	-13	-40.02	-77.72	-62.52	2.39	11.88	H	Pass

<b>Band :</b>	CDMA2000 BC1	<b>Temperature :</b>	23~24°C						
<b>Test Mode :</b>	1xEV-DO Rev. 0_RTAP 153.6K (QPSK)	<b>Relative Humidity :</b>	46~48%						
<b>Test Engineer :</b>	Jesse Wang and Derreck Chen	<b>Polarization :</b>	Vertical						
<b>Remark :</b>	Spurious emissions within 30-1000MHz were found more than 20dB below limit line.								
<b>Frequency ( MHz )</b>	<b>EIRP ( dBm )</b>	<b>Limit ( dBm )</b>	<b>Over Limit ( dB )</b>	<b>SPA Reading ( dBm )</b>	<b>S.G. Power ( dBm )</b>	<b>TX Cable loss ( dB )</b>	<b>TX Antenna Gain ( dBi )</b>	<b>Polarization ( H/V )</b>	<b>Result</b>
3819	-43.42	-13	-30.42	-57.56	-50.1	1.70	8.38	V	Pass
5726	-58.00	-13	-45.00	-76.99	-65.04	2.76	9.79	V	Pass
7635	-53.76	-13	-40.76	-77.74	-63.26	2.39	11.88	V	Pass



<EUT with PMA>

<Low Channel>

<b>Band :</b>	GSM1900		<b>Temperature :</b>	23~24°C					
<b>Test Mode :</b>	GPRS class 8 Link (GMSK)		<b>Relative Humidity :</b>	46~48%					
<b>Test Engineer :</b>	Jesse Wang and Derreck Chen		<b>Polarization :</b>	Horizontal					
<b>Remark :</b>	Spurious emissions within 30-1000MHz were found more than 20dB below limit line.								
Frequency ( MHz )	EIRP ( dBm )	Limit ( dBm )	Over Limit ( dB )	SPA Reading ( dBm )	S.G. Power ( dBm )	TX Cable loss ( dB )	TX Antenna Gain ( dBi )	Polarization ( H/V )	Result
3700	-62.79	-13	-49.79	-76.47	-69.36	1.67	8.24	H	Pass
5556	-58.40	-13	-45.40	-77.98	-65.47	2.66	9.72	H	Pass
7400	-53.19	-13	-40.19	-77.84	-62.33	2.46	11.60	H	Pass

<b>Band :</b>	GSM1900		<b>Temperature :</b>	23~24°C					
<b>Test Mode :</b>	GPRS class 8 Link (GMSK)		<b>Relative Humidity :</b>	46~48%					
<b>Test Engineer :</b>	Jesse Wang and Derreck Chen		<b>Polarization :</b>	Vertical					
<b>Remark :</b>	Spurious emissions within 30-1000MHz were found more than 20dB below limit line.								
Frequency ( MHz )	EIRP ( dBm )	Limit ( dBm )	Over Limit ( dB )	SPA Reading ( dBm )	S.G. Power ( dBm )	TX Cable loss ( dB )	TX Antenna Gain ( dBi )	Polarization ( H/V )	Result
3700	-62.46	-13	-49.46	-76.51	-69.03	1.67	8.24	V	Pass
5556	-58.07	-13	-45.07	-75.86	-65.14	2.66	9.72	V	Pass
7400	-53.73	-13	-40.73	-77.6	-62.87	2.46	11.60	V	Pass



<Middle Channel>

<b>Band :</b>	GSM1900	<b>Temperature :</b>	23~24°C						
<b>Test Mode :</b>	GPRS class 8 Link (GMSK)	<b>Relative Humidity :</b>	46~48%						
<b>Test Engineer :</b>	Jesse Wang and Derreck Chen	<b>Polarization :</b>	Horizontal						
<b>Remark :</b>	Spurious emissions within 30-1000MHz were found more than 20dB below limit line.								
Frequency ( MHz )	EIRP ( dBm )	Limit ( dBm )	Over Limit ( dB )	SPA Reading ( dBm )	S.G. Power ( dBm )	TX Cable loss ( dB )	TX Antenna Gain ( dBi )	Polarization ( H/V )	Result
3756	-61.53	-13	-48.53	-76.13	-68.15	1.68	8.31	H	Pass
5640	-54.64	-13	-41.64	-74.17	-61.69	2.71	9.76	H	Pass
7520	-53.08	-13	-40.08	-77.52	-62.47	2.42	11.81	H	Pass

<b>Band :</b>	GSM1900	<b>Temperature :</b>	23~24°C						
<b>Test Mode :</b>	GPRS class 8 Link (GMSK)	<b>Relative Humidity :</b>	46~48%						
<b>Test Engineer :</b>	Jesse Wang and Derreck Chen	<b>Polarization :</b>	Vertical						
<b>Remark :</b>	Spurious emissions within 30-1000MHz were found more than 20dB below limit line.								
Frequency ( MHz )	EIRP ( dBm )	Limit ( dBm )	Over Limit ( dB )	SPA Reading ( dBm )	S.G. Power ( dBm )	TX Cable loss ( dB )	TX Antenna Gain ( dBi )	Polarization ( H/V )	Result
3756	-61.50	-13	-48.50	-75.59	-68.12	1.68	8.31	V	Pass
5640	-54.77	-13	-41.77	-72.22	-61.82	2.71	9.76	V	Pass
7520	-54.08	-13	-41.08	-77.77	-63.47	2.42	11.81	V	Pass



<High Channel>

<b>Band :</b>	GSM1900				<b>Temperature :</b>	23~24°C			
<b>Test Mode :</b>	GPRS class 8 Link (GMSK)				<b>Relative Humidity :</b>	46~48%			
<b>Test Engineer :</b>	Jesse Wang and Derreck Chen				<b>Polarization :</b>	Horizontal			
<b>Remark :</b>	Spurious emissions within 30-1000MHz were found more than 20dB below limit line.								
Frequency ( MHz )	EIRP ( dBm )	Limit ( dBm )	Over Limit ( dB )	SPA Reading ( dBm )	S.G. Power ( dBm )	TX Cable loss ( dB )	TX Antenna Gain ( dBi )	Polarization ( H/V )	Result
3819	-61.47	-13	-48.47	-76.13	-68.15	1.70	8.38	H	Pass
5729	-56.44	-13	-43.44	-75.83	-63.47	2.76	9.79	H	Pass
7644	-52.95	-13	-39.95	-77.61	-62.45	2.38	11.89	H	Pass

<b>Band :</b>	GSM1900				<b>Temperature :</b>	23~24°C			
<b>Test Mode :</b>	GPRS class 8 Link (GMSK)				<b>Relative Humidity :</b>	46~48%			
<b>Test Engineer :</b>	Jesse Wang and Derreck Chen				<b>Polarization :</b>	Vertical			
<b>Remark :</b>	Spurious emissions within 30-1000MHz were found more than 20dB below limit line.								
Frequency ( MHz )	EIRP ( dBm )	Limit ( dBm )	Over Limit ( dB )	SPA Reading ( dBm )	S.G. Power ( dBm )	TX Cable loss ( dB )	TX Antenna Gain ( dBi )	Polarization ( H/V )	Result
3819	-62.89	-13	-49.89	-76.85	-69.57	1.70	8.38	V	Pass
5729	-56.00	-13	-43.00	-74.1	-63.03	2.76	9.79	V	Pass
7644	-54.61	-13	-41.61	-78.02	-64.11	2.38	11.89	V	Pass



<EUT with AC Adapter>

<Low Channel>

<b>Band :</b>	GSM1900	<b>Temperature :</b>	23~24°C						
<b>Test Mode :</b>	GPRS class 8 Link (GMSK)	<b>Relative Humidity :</b>	46~48%						
<b>Test Engineer :</b>	Jesse Wang and Derreck Chen	<b>Polarization :</b>	Horizontal						
<b>Remark :</b>	Spurious emissions within 30-1000MHz were found more than 20dB below limit line.								
Frequency ( MHz )	EIRP ( dBm )	Limit ( dBm )	Over Limit ( dB )	SPA Reading ( dBm )	S.G. Power ( dBm )	TX Cable loss ( dB )	TX Antenna Gain ( dBi )	Polarization ( H/V )	Result
3696	-59.64	-13	-46.64	-73.89	-66.21	1.67	8.24	H	Pass
5556	-58.96	-13	-45.96	-78.23	-66.03	2.66	9.72	H	Pass
7404	-53.32	-13	-40.32	-77.97	-62.47	2.46	11.61	H	Pass

<b>Band :</b>	GSM1900	<b>Temperature :</b>	23~24°C						
<b>Test Mode :</b>	GPRS class 8 Link (GMSK)	<b>Relative Humidity :</b>	46~48%						
<b>Test Engineer :</b>	Jesse Wang and Derreck Chen	<b>Polarization :</b>	Vertical						
<b>Remark :</b>	Spurious emissions within 30-1000MHz were found more than 20dB below limit line.								
Frequency ( MHz )	EIRP ( dBm )	Limit ( dBm )	Over Limit ( dB )	SPA Reading ( dBm )	S.G. Power ( dBm )	TX Cable loss ( dB )	TX Antenna Gain ( dBi )	Polarization ( H/V )	Result
3696	-61.64	-13	-48.64	-75.3	-68.21	1.67	8.24	V	Pass
5556	-57.12	-13	-44.12	-75.22	-64.19	2.66	9.72	V	Pass
7404	-53.83	-13	-40.83	-78.01	-62.98	2.46	11.61	V	Pass



<Middle Channel>

<b>Band :</b>	GSM1900				<b>Temperature :</b>	23~24°C			
<b>Test Mode :</b>	GPRS class 8 Link (GMSK)				<b>Relative Humidity :</b>	46~48%			
<b>Test Engineer :</b>	Jesse Wang and Derreck Chen				<b>Polarization :</b>	Horizontal			
<b>Remark :</b>	Spurious emissions within 30-1000MHz were found more than 20dB below limit line.								
Frequency ( MHz )	EIRP ( dBm )	Limit ( dBm )	Over Limit ( dB )	SPA Reading ( dBm )	S.G. Power ( dBm )	TX Cable loss ( dB )	TX Antenna Gain ( dBi )	Polarization ( H/V )	Result
3760	-60.45	-13	-47.45	-74.8	-67.08	1.69	8.31	H	Pass
5640	-58.47	-13	-45.47	-77.7	-65.52	2.71	9.76	H	Pass
7520	-53.63	-13	-40.63	-78.3	-63.02	2.42	11.81	H	Pass

<b>Band :</b>	GSM1900				<b>Temperature :</b>	23~24°C			
<b>Test Mode :</b>	GPRS class 8 Link (GMSK)				<b>Relative Humidity :</b>	46~48%			
<b>Test Engineer :</b>	Jesse Wang and Derreck Chen				<b>Polarization :</b>	Vertical			
<b>Remark :</b>	Spurious emissions within 30-1000MHz were found more than 20dB below limit line.								
Frequency ( MHz )	EIRP ( dBm )	Limit ( dBm )	Over Limit ( dB )	SPA Reading ( dBm )	S.G. Power ( dBm )	TX Cable loss ( dB )	TX Antenna Gain ( dBi )	Polarization ( H/V )	Result
3760	-61.40	-13	-48.40	-75.49	-68.03	1.69	8.31	V	Pass
5640	-56.17	-13	-43.17	-73.59	-63.22	2.71	9.76	V	Pass
7520	-54.93	-13	-41.93	-78.19	-64.32	2.42	11.81	V	Pass



<High Channel>

<b>Band :</b>	GSM1900				<b>Temperature :</b>	23~24°C			
<b>Test Mode :</b>	GPRS class 8 Link (GMSK)				<b>Relative Humidity :</b>	46~48%			
<b>Test Engineer :</b>	Jesse Wang and Derreck Chen				<b>Polarization :</b>	Horizontal			
<b>Remark :</b>	Spurious emissions within 30-1000MHz were found more than 20dB below limit line.								
Frequency ( MHz )	EIRP ( dBm )	Limit ( dBm )	Over Limit ( dB )	SPA Reading ( dBm )	S.G. Power ( dBm )	TX Cable loss ( dB )	TX Antenna Gain ( dBi )	Polarization ( H/V )	Result
3819	-61.84	-13	-48.84	-76.47	-68.52	1.70	8.38	H	Pass
5736	-57.18	-13	-44.18	-76.51	-64.21	2.76	9.79	H	Pass
7639	-53.97	-13	-40.97	-78.03	-63.47	2.38	11.88	H	Pass

<b>Band :</b>	GSM1900				<b>Temperature :</b>	23~24°C			
<b>Test Mode :</b>	GPRS class 8 Link (GMSK)				<b>Relative Humidity :</b>	46~48%			
<b>Test Engineer :</b>	Jesse Wang and Derreck Chen				<b>Polarization :</b>	Vertical			
<b>Remark :</b>	Spurious emissions within 30-1000MHz were found more than 20dB below limit line.								
Frequency ( MHz )	EIRP ( dBm )	Limit ( dBm )	Over Limit ( dB )	SPA Reading ( dBm )	S.G. Power ( dBm )	TX Cable loss ( dB )	TX Antenna Gain ( dBi )	Polarization ( H/V )	Result
3819	-62.90	-13	-49.90	-77.1	-69.58	1.70	8.38	V	Pass
5736	-58.00	-13	-45.00	-76.25	-65.03	2.76	9.79	V	Pass
7639	-53.97	-13	-40.97	-77.69	-63.47	2.38	11.88	V	Pass



## 3.8 Frequency Stability Measurement

### 3.8.1 Description of Frequency Stability Measurement

The frequency stability shall be measured by variation of ambient temperature and variation of primary supply voltage to ensure that the fundamental emission stays within the authorized frequency block. The frequency stability of the transmitter shall be maintained within  $\pm 0.00025\%$  ( $\pm 2.5\text{ppm}$ ) of the center frequency.

### 3.8.2 Measuring Instruments

The measuring equipment is listed in the section 4 of this test report.

### 3.8.3 Test Procedures for Temperature Variation

1. The testing follows FCC KDB 971168 v02r02 Section 9.0.
2. The EUT was set up in the thermal chamber and connected with the system simulator.
3. With power OFF, the temperature was decreased to  $-30^{\circ}\text{C}$  and the EUT was stabilized before testing. Power was applied and the maximum change in frequency was recorded within one minute.
4. With power OFF, the temperature was raised in  $10^{\circ}\text{C}$  steps up to  $50^{\circ}\text{C}$ . The EUT was stabilized at each step for at least half an hour. Power was applied and the maximum frequency change was recorded within one minute.

### 3.8.4 Test Procedures for Voltage Variation

1. The testing follows FCC KDB 971168 v02r02 Section 9.0.
2. The EUT was placed in a temperature chamber at  $25\pm 5^{\circ}\text{C}$  and connected with the system simulator.
3. The power supply voltage to the EUT was varied from BEP to 115% of the nominal value measured at the input to the EUT.
4. The variation in frequency was measured for the worst case.

### 3.8.5 Test Setup

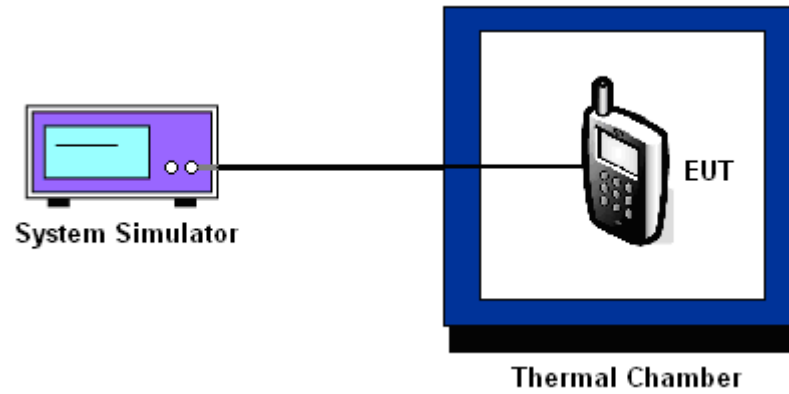



3.8.6 Test Result of Temperature Variation

<b>Band :</b>	GSM 850	<b>Channel :</b>	189
<b>Limit (ppm) :</b>	2.5	<b>Frequency :</b>	836.4 MHz

Temperature (°C)	GPRS class 8	EDGE class 8	Result
	Deviation (ppm)	Deviation (ppm)	
50	0.0108	0.0084	PASS
40	0.0024	0.0120	
30	0.0096	0.0096	
20(Ref.)	0.0000	0.0000	
10	0.0036	0.0036	
0	0.0072	0.0072	
-10	0.0024	0.0132	
-20	0.0120	0.0108	
-30	0.0060	0.0060	

<b>Band :</b>	GSM 1900	<b>Channel :</b>	661
<b>Limit (ppm) :</b>	within authorized band	<b>Frequency :</b>	1880.0 MHz

Temperature (°C)	GPRS class 8	EDGE class 8	Result
	Deviation (ppm)	Deviation (ppm)	
50	0.0064	0.0048	PASS
40	0.0011	0.0074	
30	0.0021	0.0011	
20(Ref.)	0.0000	0.0000	
10	0.0016	0.0032	
0	0.0090	0.0122	
-10	0.0106	0.0112	
-20	0.0085	0.0128	
-30	0.0128	0.0144	

Note: The frequency fundamental emissions stay within the authorized frequency block based on the frequency deviation measured is small.



<b>Band :</b>	WCDMA Band V	<b>Channel :</b>	4182
<b>Limit (ppm) :</b>	2.5	<b>Frequency :</b>	836.4 MHz

Temperature (°C)	RMC 12.2Kbps	Result
	Deviation (ppm)	
50	0.0024	PASS
40	0.0036	
30	0.0120	
20(Ref.)	0.0000	
10	0.0024	
0	0.0012	
-10	0.0024	
-20	0.0084	
-30	0.0012	

<b>Band :</b>	WCDMA Band II	<b>Channel :</b>	9400
<b>Limit (ppm) :</b>	within authorized band	<b>Frequency :</b>	1880.0 MHz

Temperature (°C)	RMC 12.2Kbps	Result
	Deviation (ppm)	
50	0.0021	PASS
40	0.0011	
30	0.0059	
20(Ref.)	0.0000	
10	0.0074	
0	0.0053	
-10	0.0048	
-20	0.0069	
-30	0.0064	

Note: The frequency fundamental emissions stay within the authorized frequency block based on the frequency deviation measured is small.



<b>Band :</b>	CDMA2000 BC0 1xRTT_RC1+SO55	<b>Channel :</b>	384
<b>Limit (ppm) :</b>	2.5	<b>Frequency :</b>	836.52 MHz

Temperature (°C)	Deviation (ppm)	Result
50	0.0203	PASS
40	0.0167	
30	0.0155	
20(Ref.)	0.0000	
10	0.0072	
0	0.0012	
-10	0.0024	
-20	0.0048	
-30	0.0024	

<b>Band :</b>	CDMA2000 BC0 1xEV-DO Rev. 0_RTAP 153.6K	<b>Channel :</b>	384
<b>Limit (ppm) :</b>	2.5	<b>Frequency :</b>	836.52 MHz

Temperature (°C)	Deviation (ppm)	Result
50	0.0072	PASS
40	0.0012	
30	0.0167	
20(Ref.)	0.0000	
10	0.0203	
0	0.0120	
-10	0.0191	
-20	0.0131	
-30	0.0179	



<b>Band :</b>	CDMA2000 BC1 1xRTT_RC1+SO55	<b>Channel :</b>	600
<b>Limit (ppm) :</b>	within authorized band	<b>Frequency :</b>	1880.0 MHz

Temperature (°C)	Deviation (ppm)	Result
50	0.0234	PASS
40	0.0239	
30	0.0043	
20(Ref.)	0.0000	
10	0.0021	
0	0.0027	
-10	0.0053	
-20	0.0037	
-30	0.0016	

<b>Band :</b>	CDMA2000 BC1 1xEV-DO Rev. 0_RTAP 153.6K	<b>Channel :</b>	600
<b>Limit (ppm) :</b>	within authorized band	<b>Frequency :</b>	1880.0 MHz

Temperature (°C)	Deviation (ppm)	Result
50	0.0282	PASS
40	0.0298	
30	0.0005	
20(Ref.)	0.0000	
10	0.0037	
0	0.0053	
-10	0.0005	
-20	0.0011	
-30	0.0032	

Note: The frequency fundamental emissions stay within the authorized frequency block based on the frequency deviation measured is small.



3.8.7 Test Result of Voltage Variation

Band & Channel	Mode	Voltage (Volt)	Deviation (ppm)	Limit (ppm)	Result
GSM 850 CH189	GPRS class 8	4.35	0.0012	2.5	PASS
		3.90	0.0084		
		BEP	0.0048		
	EDGE class 8	4.35	0.0143		
		3.90	0.0048		
		BEP	0.0096		
GSM 1900 CH661	GPRS class 8	4.35	0.0005	(Note 3.)	
		3.90	0.0011		
		BEP	0.0027		
	EDGE class 8	4.35	0.0090		
		3.90	0.0048		
		BEP	0.0064		
WCDMA Band V CH4182	RMC 12.2Kbps	4.35	0.0048	2.5	
		3.90	0.0036		
		BEP	0.0012		
WCDMA Band II CH9400	RMC 12.2Kbps	4.35	0.0000	(Note 3.)	
		3.90	0.0011		
		BEP	0.0005		
CDMA2000 BC0 CH384	1xRTT RC1+SO55	4.35	0.0012	2.5	
		3.90	0.0143		
		BEP	0.0131		
CDMA2000 BC0 CH600	1xEV-DO Rev. 0 RTAP 153.6K	4.35	0.0155	2.5	
		3.90	0.0012		
		BEP	0.0143		
CDMA2000 BC1 CH384	1xRTT RC1+SO55	4.35	0.0011	(Note 3.)	
		3.90	0.0032		
		BEP	0.0027		
CDMA2000 BC1 CH600	1xEV-DO Rev. 0 RTAP 153.6K	4.35	0.0016	(Note 3.)	
		3.90	0.0043		
		BEP	0.0048		

Note:

1. Normal Voltage = 3.90V.
2. Battery End Point (BEP) = 3.40 V.
3. The frequency fundamental emissions stay within the authorized frequency block based on the frequency deviation measured is small.



## 4 List of Measuring Equipment

Instrument	Manufacturer	Model No.	Serial No.	Characteristics	Calibration Date	Test Date	Due Date	Remark
Signal Generator	Rohde & Schwarz	SMU200A	102502	9kHz~6GHz	Jul. 07, 2014	Jun. 16, 2015 ~ Jun. 17, 2015	Jul. 06, 2015	Conducted (TH03-HY)
Base Station(Measu	Rohde & Schwarz	CMU200	117995	GSM / GPRS / WCDMA / CDMA	Jul. 29, 2014	Jun. 16, 2015 ~ Jun. 17, 2015	Jul. 28, 2015	Conducted (TH03-HY)
Programmable Power Supply	GW Instek	PSS-2005	EL883644	Voltage:0~20V;Current:0~5A	Dec. 01, 2014	Jun. 16, 2015 ~ Jun. 17, 2015	Nov. 30, 2015	Conducted (TH03-HY)
Temperature Chamber	ESPEC	SU-641	92013721	-30°C~70°C	Dec. 01, 2014	Jun. 16, 2015 ~ Jun. 17, 2015	Nov. 30, 2015	Conducted (TH03-HY)
EMI Test Receiver	Keysight	N9038A	MY54130085	20Hz ~ 8.4GHz	Nov. 05, 2014	Jun. 05, 2015 ~ Jun. 09, 2015	Nov. 04, 2015	Radiation (03CH11-HY)
Amplifier	SONOMA	310N	187312	9kHz~1GHz	Nov. 24, 2014	Jun. 05, 2015 ~ Jun. 09, 2015	Nov. 23, 2015	Radiation (03CH11-HY)
Bilog Antenna	TESEQ	CBL 6111D	35414	30MHz~1GHz	Oct. 24, 2014	Jun. 05, 2015 ~ Jun. 09, 2015	Oct. 23, 2015	Radiation (03CH11-HY)
Horn Antenna	SCHWARZBECK	BBHA 9120 D	9120D-1326	1GHz ~ 18GHz	Oct. 03, 2014	Jun. 05, 2015 ~ Jun. 09, 2015	Oct. 02, 2015	Radiation (03CH11-HY)
Horn Antenna	SCHWARZBECK	BBHA 9120 D	9120D-1325	1GHz ~ 18GHz	Oct. 03, 2014	Jun. 05, 2015 ~ Jun. 09, 2015	Oct. 02, 2015	Radiation (03CH11-HY)
SHF-EHF Horn Antenna	SCHWARZBECK	BBHA 9170	BBHA917025 1	18GHz- 40GHz	Oct. 02, 2014	Jun. 05, 2015 ~ Jun. 09, 2015	Oct. 01, 2015	Radiation (03CH11-HY)
Preamplifier	Keysight	83017A	MY53270080	1GHz~26.5GHz	Nov. 20, 2014	Jun. 05, 2015 ~ Jun. 09, 2015	Nov. 19, 2015	Radiation (03CH11-HY)
Spectrum Analyzer	Keysight	N9010A	MY54200486	10Hz ~ 44GHZ	Sep. 24, 2014	Jun. 05, 2015 ~ Jun. 09, 2015	Sep. 23, 2015	Radiation (03CH11-HY)
Antenna Mast	EMEC	AM-BS-4500-B	N/A	1~4m	NA	Jun. 05, 2015 ~ Jun. 09, 2015	NA	Radiation (03CH11-HY)
Turn Table	EMEC	TT 2000	N/A	0-360 degree	NA	Jun. 05, 2015 ~ Jun. 09, 2015	NA	Radiation (03CH11-HY)
Signal Generator	Rohde & Schwarz	SMF100A	101107	100kHz~40GHz	May 22, 2015	Jun. 05, 2015 ~ Jun. 09, 2015	May 21, 2016	Radiation (03CH11-HY)



## 5 Uncertainty of Evaluation

### Uncertainty of Radiated Emission Measurement (30 MHz ~ 1000 MHz)

Measuring Uncertainty for a Level of Confidence of 95% ( $U = 2Uc(y)$ )	4.9
---	-----