



# FCC RF Test Report

**APPLICANT** : Motorola Mobility LLC  
**EQUIPMENT** : Cellular Mobile Phone  
**BRAND NAME** : Motorola  
**MODEL NAME** : 4474  
**FCC ID** : IHDT56QE4  
**STANDARD** : FCC 47 CFR Part 2, 22(H), 24(E)  
**CLASSIFICATION** : PCS Licensed Transmitter Held to Ear (PCE)

The product was received on Oct. 21, 2014. We, SPORTON INTERNATIONAL INC., would like to declare that the tested sample has been evaluated in accordance with the test procedures given in ANSI / TIA / EIA-603-C-2004 and has been in compliance with the applicable technical standards.

The test results in this report apply exclusively to the tested model / sample. Without written approval of SPORTON INTERNATIONAL INC., the test report shall not be reproduced except in full.

Reviewed by: Joseph Lin / Supervisor

Approved by: Jones Tsai / Manager



## SPORTON INTERNATIONAL INC.

No. 52, Hwa Ya 1<sup>st</sup> Rd., Hwa Ya Technology Park, Kwei-Shan Hsiang, Tao Yuan Hsien, Taiwan, R.O.C.



# TABLE OF CONTENTS

REVISION HISTORY..... 3

1 GENERAL DESCRIPTION ..... 4

    1.1 Applicant..... 4

    1.2 Manufacturer ..... 4

    1.3 Product Feature of Equipment Under Test ..... 4

    1.4 Product Specification subjective to this standard ..... 5

    1.5 Modification of EUT ..... 5

APPENDIX A. ORIGINAL REPORT



### REVISION HISTORY

REPORT NO.	VERSION	DESCRIPTION	ISSUED DATE
FG4O1411-03A	Rev. 01	The WWAN circuit of this variant model (4474) is identical to that of the parent product (4486), based on the product equality declaration by the manufacturer.	Jan. 14, 2015
FG4O1411-03A	Rev. 02	Updating the original report in Appendix A	Aug. 04, 2015



# 1 General Description

## 1.1 Applicant

**Motorola Mobility LLC**

222 W. Merchandise Mart Plaza, Suite 1800, Chicago IL. 60654, United States

## 1.2 Manufacturer

**Motorola Mobility LLC**

222 W. Merchandise Mart Plaza, Suite 1800, Chicago IL. 60654, United States

## 1.3 Product Feature of Equipment Under Test

Product Feature	
Equipment	Cellular Mobile Phone
Brand Name	Motorola
Model Name	4474
FCC ID	IHDT56QE4
EUT supports Radios application	GSM/EGPRS/WCDMA/HSPA/LTE WLAN 11b/g/n HT20 Bluetooth v2.1 EDR Bluetooth v4.0 - LE
EUT Stage	Identical Prototype

**Remark:** The above EUT's information was declared by manufacturer. Please refer to the specifications or user's manual for more detailed description.



### 1.4 Product Specification subjective to this standard

Product Specification subjective to this standard	
<b>Tx Frequency</b>	GSM850: 824.2 MHz ~ 848.8 MHz GSM1900: 1850.2 MHz ~ 1909.8MHz WCDMA Band V: 826.4 MHz ~ 846.6 MHz WCDMA Band II: 1852.4 MHz ~ 1907.6 MHz
<b>Rx Frequency</b>	GSM850: 869.2 MHz ~ 893.8 MHz GSM1900: 1930.2 MHz ~ 1989.8 MHz WCDMA Band V: 871.4 MHz ~ 891.6 MHz WCDMA Band II: 1932.4 MHz ~ 1987.6 MHz
<b>Antenna Type</b>	Coupling type (LDS)
<b>Type of Modulation</b>	GSM: GMSK GPRS: GMSK EDGE: GMSK / 8PSK WCDMA: QPSK (Uplink) HSDPA: 64QAM (Downlink) HSUPA: QPSK (Uplink)

**Remark:** The GSM/EDGE 850, GSM/EDGE 1900, WCDMA Band V and WCDMA Band II test results refer to appendix A.

### 1.5 Modification of EUT

No modifications are made to the EUT during all test items.



## **Appendix A. Original Report**

Please refer to Sporton report number FG4O1411 as below.



# FCC RF Test Report

**APPLICANT** : Motorola Mobility LLC  
**EQUIPMENT** : Cellular Mobile Phone  
**BRAND NAME** : Motorola  
**MODEL NAME** : 4486  
**FCC ID** : IHDT56QE2  
**STANDARD** : FCC 47 CFR Part 2, 22(H), 24(E)  
**CLASSIFICATION** : PCS Licensed Transmitter Held to Ear (PCE)

The product was received on Oct. 14, 2014 and testing was completed on Oct. 18, 2014. We, SPORTON INTERNATIONAL INC., would like to declare that the tested sample has been evaluated in accordance with the test procedures given in ANSI / TIA / EIA-603-C-2004 and has been in compliance with the applicable technical standards.

The test results in this report apply exclusively to the tested model / sample. Without written approval of SPORTON INTERNATIONAL INC., the test report shall not be reproduced except in full.

Reviewed by: Joseph Lin / Supervisor

Approved by: Jones Tsai / Manager



## SPORTON INTERNATIONAL INC.

No. 52, Hwa Ya 1<sup>st</sup> Rd., Hwa Ya Technology Park, Kwei-Shan Hsiang, Tao Yuan Hsien, Taiwan, R.O.C.



# TABLE OF CONTENTS

**REVISION HISTORY.....3**

**SUMMARY OF TEST RESULT .....4**

**1 GENERAL DESCRIPTION.....5**

1.1 Applicant.....5

1.2 Manufacturer .....5

1.3 Product Feature of Equipment Under Test .....5

1.4 Product Specification subjective to this standard.....6

1.5 Modification of EUT .....6

1.6 Maximum ERP/EIRP Power, Frequency Tolerance, and Emission Designator .....6

1.7 Testing Location .....7

1.8 Applicable Standards .....7

**2 TEST CONFIGURATION OF EQUIPMENT UNDER TEST.....8**

2.1 Test Mode.....8

2.2 Connection Diagram of Test System ..... 10

2.3 Support Unit used in test configuration ..... 10

2.4 Measurement Results Explanation Example ..... 10

**3 TEST RESULT..... 11**

3.1 Conducted Output Power Measurement..... 11

3.2 Peak-to-Average Ratio ..... 13

3.3 Effective Radiated Power and Effective Isotropic Radiated Power Measurement .....27

3.4 99% Occupied Bandwidth and 26dB Bandwidth Measurement.....33

3.5 Band Edge Measurement.....53

3.6 Conducted Spurious Emission Measurement..... 60

3.7 Field Strength of Spurious Radiation Measurement ..... 106

3.8 Frequency Stability Measurement..... 126

**4 LIST OF MEASURING EQUIPMENT..... 131**

**5 UNCERTAINTY OF EVALUATION..... 132**



### REVISION HISTORY

REPORT NO.	VERSION	DESCRIPTION	ISSUED DATE
FG4O1411	Rev. 01	Initial issue of report	Nov. 17, 2014



## SUMMARY OF TEST RESULT

Report Section	FCC Rule	Description	Limit	Result	Remark
3.1	§2.1046	Conducted Output Power	N/A	PASS	-
3.2	§24.232(d)	Peak-to-Average Ratio	<13 dB	PASS	-
3.3	§22.913(a)(2)	Effective Radiated Power	< 7 Watts	PASS	-
	§24.232(c)	Equivalent Isotropic Radiated Power	< 2 Watts	PASS	-
3.4	§2.1049 §22.917(b) §24.238(b)	Occupied Bandwidth	N/A	PASS	-
3.5	§2.1051 §22.917(a) §24.238(a)	Band Edge Measurement	< 43+10log <sub>10</sub> (P[Watts])	PASS	-
3.6	§2.1051 §22.917(a) §24.238(a)	Conducted Spurious Emission	< 43+10log <sub>10</sub> (P[Watts])	PASS	-
3.7	§2.1053 §22.917(a) §24.238(a)	Field Strength of Spurious Radiation	< 43+10log <sub>10</sub> (P[Watts])	PASS	Under limit 14.70 dB at 7641.000 MHz
3.8	§2.1055 §22.355	Frequency Stability for Temperature & Voltage	< 2.5 ppm for Part 22 Within Authorized Band	PASS	-
	§2.1055 §24.235				



# 1 General Description

## 1.1 Applicant

Motorola Mobility LLC

222 W. Merchandise Mart Plaza, Suite 1800, Chicago IL. 60654, United States

## 1.2 Manufacturer

Motorola Mobility LLC

222 W. Merchandise Mart Plaza, Suite 1800, Chicago IL. 60654, United States

## 1.3 Product Feature of Equipment Under Test

Product Feature	
Equipment	Cellular Mobile Phone
Brand Name	Motorola
Model Name	4486
FCC ID	IHDT56QE2
IMEI Code	SIM 1: 355452060023938 SIM 2: 355452060023946
EUT supports Radios application	GSM/EGPRS/WCDMA/HSPA WLAN 11b/g/n HT20 Bluetooth v2.1 EDR Bluetooth v4.0 - LE
HW Version	P2A
SW Version	KXB21.161_942
EUT Stage	Identical Prototype

Remark: The above EUT's information was declared by manufacturer. Please refer to the specifications or user's manual for more detailed description.

Accessory List	
AC Adapter	Brand Name : MOTOROLA
	Model Name : SPN5810A
Battery	Brand Name : MOTOROLA
	Model Name : FT40
Earphone	Brand Name : MOTOROLA
	Model Name : SJYN1181B



### 1.4 Product Specification subjective to this standard

Product Specification subjective to this standard	
<b>Tx Frequency</b>	GSM850: 824.2 MHz ~ 848.8 MHz GSM1900: 1850.2 MHz ~ 1909.8MHz WCDMA Band V: 826.4 MHz ~ 846.6 MHz WCDMA Band II: 1852.4 MHz ~ 1907.6 MHz
<b>Rx Frequency</b>	GSM850: 869.2 MHz ~ 893.8 MHz GSM1900: 1930.2 MHz ~ 1989.8 MHz WCDMA Band V: 871.4 MHz ~ 891.6 MHz WCDMA Band II: 1932.4 MHz ~ 1987.6 MHz
<b>Maximum Output Power to Antenna</b>	GSM850 : 33.73 dBm GSM1900 : 31.00 dBm WCDMA Band V : 24.25 dBm WCDMA Band II : 23.55 dBm
<b>Antenna Type</b>	PIFA Antenna
<b>Type of Modulation</b>	GSM: GMSK GPRS: GMSK EDGE: GMSK / 8PSK WCDMA: QPSK (Uplink) HSDPA: 64QAM (Downlink) HSUPA: QPSK (Uplink)

### 1.5 Modification of EUT

No modifications are made to the EUT during all test items.

### 1.6 Maximum ERP/EIRP Power, Frequency Tolerance, and Emission Designator

FCC Rule	System	Type of Modulation	Maximum ERP/EIRP (W)	Frequency Tolerance (ppm)	Emission Designator
Part 22	GSM850 GPRS class 8	GMSK	1.01	0.0777 ppm	248KGXW
Part 22	GSM850 EDGE class 8	8PSK	0.20	0.0478 ppm	248KG7W
Part 22	WCDMA Band V RMC 12.2Kbps	QPSK	0.10	0.0108 ppm	4M18F9W
Part 24	GSM1900 GSM	GMSK	1.92	0.0064 ppm	248KGXW
Part 24	GSM1900 EDGE class 8	8PSK	0.51	0.0032 ppm	248KG7W
Part 24	WCDMA Band II RMC 12.2Kbps	QPSK	0.34	0.0080 ppm	4M18F9W



### 1.7 Testing Location

Sporton Lab is accredited to ISO 17025 by Taiwan Accreditation Foundation (TAF code : 1190) and the FCC designation No. TW1022 under the FCC 2.948(e) by Mutual Recognition Agreement (MRA) in FCC Test.

<b>Test Site</b>	SPORTON INTERNATIONAL INC.	
<b>Test Site Location</b>	No. 52, Hwa Ya 1 <sup>st</sup> Rd., Hwa Ya Technology Park, Kwei-Shan Hsiang, Tao Yuan Hsien, Taiwan, R.O.C. TEL: +886-3-327-3456 FAX: +886-3-328-4978	
<b>Test Site No.</b>	<b>Sporton Site No.</b>	
	TH02-HY	03CH07-HY

### 1.8 Applicable Standards

According to the specifications of the manufacturer, the EUT must comply with the requirements of the following standards:

- ♦ FCC 47 CFR Part 2, 22(H), 24(E)
- ♦ ANSI / TIA / EIA-603-C-2004
- ♦ FCC KDB 971168 D01 Power Meas. License Digital Systems v02r02

**Remark:**

1. All test items were verified and recorded according to the standards and without any deviation during the test.
2. This EUT has also been tested and complied with the requirements of FCC Part 15, Subpart B, recorded in a separate test report.



## 2 Test Configuration of Equipment Under Test

### 2.1 Test Mode

Antenna port conducted and radiated test items were performed according to KDB 971168 D01 Power Meas. License Digital Systems v02r02 with maximum output power.

Radiated measurements were performed with rotating EUT in different three orthogonal test planes to find the maximum emission.

Radiated emissions were investigated as following frequency range:

1. 30 MHz to 9000 MHz for GSM850 and WCDMA Band V.
2. 30 MHz to 19000 MHz for GSM1900 and WCDMA Band II.

All modes and data rates and positions were investigated.

Test modes are chosen to be reported as the worst case configuration below:

Test Modes		
Band	Radiated TCs	Conducted TCs
GSM 850	<ul style="list-style-type: none"> <li>■ GPRS class 8 Link</li> <li>■ EDGE class 8 Link</li> </ul>	<ul style="list-style-type: none"> <li>■ GPRS class 8 Link</li> <li>■ EDGE class 8 Link</li> </ul>
GSM 1900	<ul style="list-style-type: none"> <li>■ GSM Link</li> <li>■ EDGE class 8 Link</li> </ul>	<ul style="list-style-type: none"> <li>■ GSM Link</li> <li>■ EDGE class 8 Link</li> </ul>
WCDMA Band V	<ul style="list-style-type: none"> <li>■ RMC 12.2Kbps Link</li> </ul>	<ul style="list-style-type: none"> <li>■ RMC 12.2Kbps Link</li> </ul>
WCDMA Band II	<ul style="list-style-type: none"> <li>■ RMC 12.2Kbps Link</li> </ul>	<ul style="list-style-type: none"> <li>■ RMC 12.2Kbps Link</li> </ul>

**Note:** The maximum power levels are chosen to test as the worst case configuration as follows:

GPRS multi-slot class 8 mode for GMSK modulation for GSM850,

GSM mode for GMSK modulation for GSM1900,

EDGE multi-slot class 8 mode for 8PSK modulation,

RMC 12.2Kbps mode for WCDMA band V and WCDMA band II,

only these modes were used for all tests. In addition to above worst-case test, below investigating on all data rates, and all modes are compliance with each FCC test case which has specific test limits. For spurious emissions at antenna port, the EUT was investigated the band edges on low and high channels, and the unwanted spurious emissions on middle channel for all modes, the results are pass, then only the worst-results were reported in the test report. The Radiated Spurious emissions for GSM/GPRS/EGPRS/HSDPA modes were investigated on the middle channel and the passed results were not worst than those data tested from the highest power channels.



Conducted Power Measurement Results:

Conducted Power (*Unit: dBm)						
Band	GSM850			GSM1900		
Channel	128	189	251	512	661	810
Frequency	824.2	836.4	848.8	1850.2	1880.0	1909.8
GSM	33.68	33.71	33.65	30.92	31.00	30.97
GPRS class 8	33.73	33.72	33.69	30.93	30.99	30.96
GPRS class 10	33.24	33.20	33.15	29.00	29.08	29.05
GPRS class 11	29.02	29.00	28.91	26.95	27.05	27.01
GPRS class 12	27.50	27.45	27.42	24.73	24.91	24.80
EGPRS class 8	27.46	27.48	27.50	26.59	26.52	26.51
EGPRS class 10	25.47	25.50	25.52	24.58	24.55	24.51
EGPRS class 11	23.34	23.36	23.40	22.50	22.46	22.41
EGPRS class 12	21.78	21.80	21.85	20.74	20.70	20.67

Conducted Power (*Unit: dBm)						
Band	WCDMA Band V			WCDMA Band II		
Channel	4132	4182	4233	9262	9400	9538
Frequency	826.4	836.4	846.6	1852.4	1880.0	1907.6
RMC 12.2K	24.25	24.23	24.18	23.55	23.44	23.52
HSDPA Subtest-1	23.27	23.24	23.32	22.52	22.55	22.54
HSDPA Subtest-2	23.26	23.22	23.28	22.50	22.49	22.53
HSDPA Subtest-3	22.80	22.84	22.86	21.99	22.00	22.02
HSDPA Subtest-4	22.79	22.81	22.95	22.01	22.03	22.00
HSUPA Subtest-1	22.66	23.00	22.98	22.62	22.37	22.57
HSUPA Subtest-2	21.53	21.65	21.70	21.00	20.79	20.99
HSUPA Subtest-3	22.05	22.27	22.24	21.28	20.98	21.13
HSUPA Subtest-4	21.95	22.15	22.14	21.86	21.55	21.69
HSUPA Subtest-5	23.28	23.24	23.25	22.47	22.53	22.48

## 2.2 Connection Diagram of Test System

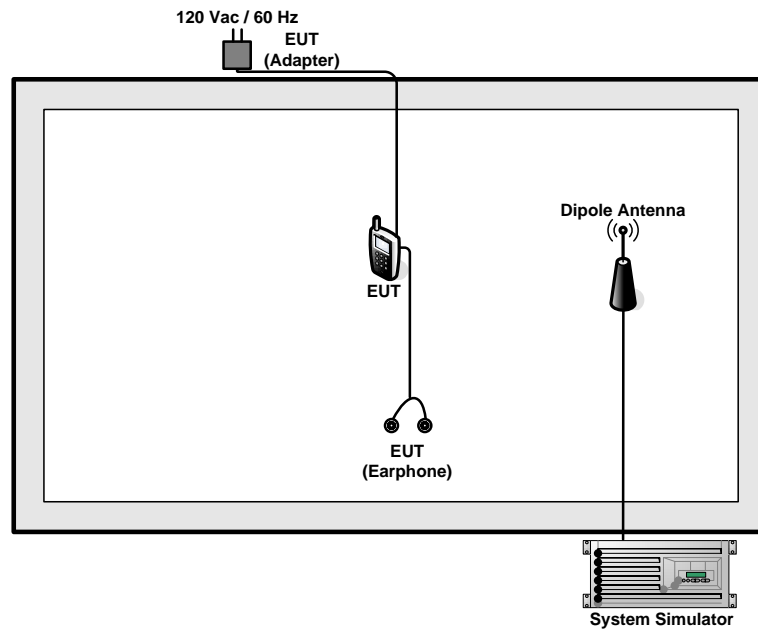

## 2.3 Support Unit used in test configuration

Item	Equipment	Trade Name	Model No.	FCC ID	Data Cable	Power Cord
1.	System Simulator	R&S	CMU 200	N/A	N/A	Unshielded, 1.8 m

## 2.4 Measurement Results Explanation Example

For all conducted test items:

The offset level is set in the spectrum analyzer to compensate the RF cable loss and attenuator factor between RF conducted output port and spectrum analyzer. With the offset compensation, the spectrum analyzer reading level will be exactly the RF output level.

The spectrum analyzer offset is derived from RF cable loss and attenuator factor.

*Offset = RF cable loss + attenuator factor.*

The following shows an offset computation example with RF cable loss 4.2 dB and a 10dB attenuator.

Example :

*Offset(dB) = RF cable loss(dB) + attenuator factor(dB).*

$$= 4.2 + 10 = 14.2 \text{ (dB)}$$

### **3 Test Result**

#### **3.1 Conducted Output Power Measurement**

##### **3.1.1 Description of the Conducted Output Power Measurement**

A system simulator was used to establish communication with the EUT. Its parameters were set to enforce EUT transmitting at the maximum power. The measured power in the radio frequency on the transmitter output terminals shall be reported.

##### **3.1.2 Measuring Instruments**

The measuring equipment is listed in the section 4 of this test report.

##### **3.1.3 Test Procedures**

1. The transmitter output port was connected to the system simulator.
2. Set EUT at maximum power through system simulator.
3. Select lowest, middle, and highest channels for each band and different modulation.
4. Measure the maximum burst average power for GSM and maximum average power for other modulation signal.

##### **3.1.4 Test Setup**

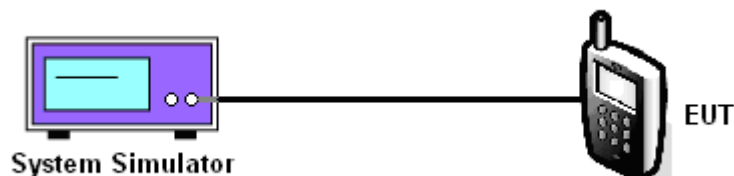



3.1.5 Test Result of Conducted Output Power

Cellular Band									
Modes	GSM850 (GPRS class 8)			GSM850 (EDGE class 8)			WCDMA Band V (RMC 12.2Kbps)		
Channel	128 (Low)	189 (Mid)	251 (High)	128 (Low)	189 (Mid)	251 (High)	4132 (Low)	4182 (Mid)	4233 (High)
Frequency (MHz)	824.2	836.4	848.8	824.2	836.4	848.8	826.4	836.4	846.6
Conducted Power (dBm)	33.73	33.72	33.69	27.46	27.48	27.50	24.25	24.23	24.18

PCS Band									
Modes	GSM1900 (GSM)			GSM1900 (EDGE class 8)			WCDMA Band II (RMC 12.2Kbps)		
Channel	512 (Low)	661 (Mid)	810 (High)	512 (Low)	661 (Mid)	810 (High)	9262 (Low)	9400 (Mid)	9538 (High)
Frequency (MHz)	1850.2	1880	1909.8	1850.2	1880	1909.8	1852.4	1880	1907.6
Conducted Power (dBm)	30.92	31.00	30.97	26.59	26.52	26.51	23.55	23.44	23.52

**Note:** maximum burst average power for GSM, and maximum average power for WCDMA.

## 3.2 Peak-to-Average Ratio

### 3.2.1 Description of the PAR Measurement

The peak-to-average ratio (PAR) of the transmission may not exceed 13 dB.

### 3.2.2 Measuring Instruments

The measuring equipment is listed in the section 4 of this test report.

### 3.2.3 Test Procedures

1. The testing follows FCC KDB 971168 v02r01 Section 5.7.1.
2. The EUT was connected to spectrum analyzer and system simulator via a power divider.
3. Set EUT to transmit at maximum output power.
4. For GSM/EGPRS operating modes, signal gating is implemented on the spectrum analyzer by triggering from the system simulator.
5. Set the CCDF (Complementary Cumulative Distribution Function) option of the spectrum analyzer.  
Record the maximum PAPR level associated with a probability of 0.1%.

### 3.2.4 Test Setup

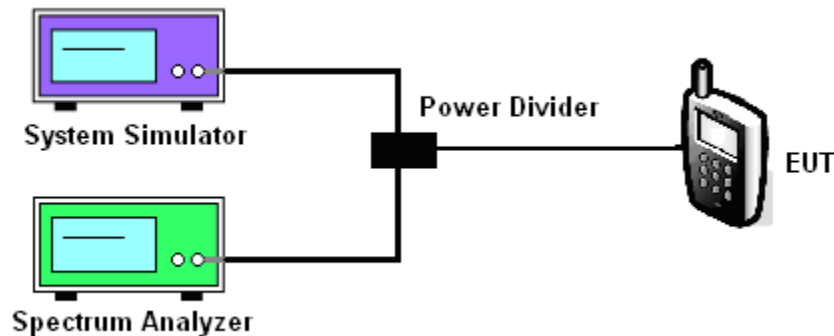



3.2.5 Test Result of Peak-to-Average Ratio

Cellular Band									
Modes	GSM850 (GPRS class 8)			GSM850 (EDGE class 8)			WCDMA Band V (RMC 12.2Kbps)		
Channel	128 (Low)	189 (Mid)	251 (High)	128 (Low)	189 (Mid)	251 (High)	4132 (Low)	4182 (Mid)	4233 (High)
Frequency (MHz)	824.2	836.4	848.8	824.2	836.4	848.8	826.4	836.4	846.6
Peak-to-Average Ratio (dB)	0.24	0.28	0.24	3.36	3.16	2.92	3.04	2.92	3.28

PCS Band									
Modes	GSM1900 (GSM)			GSM1900 (EDGE class 8)			WCDMA Band II (RMC 12.2Kbps)		
Channel	512 (Low)	661 (Mid)	810 (High)	512 (Low)	661 (Mid)	810 (High)	9262 (Low)	9400 (Mid)	9538 (High)
Frequency (MHz)	1850.2	1880	1909.8	1850.2	1880	1909.8	1852.4	1880	1907.6
Peak-to-Average Ratio (dB)	0.24	0.28	0.24	3.24	2.96	3.52	3.12	3.32	3.04



### 3.2.6 Test Result (Plots) of Peak-to-Average Ratio

Band :	GSM 850	Test Mode :	GPRS class 8 Link (GMSK)
--------	---------	-------------	--------------------------

#### Peak-to-Average Ratio on Channel 128 (824.2 MHz)

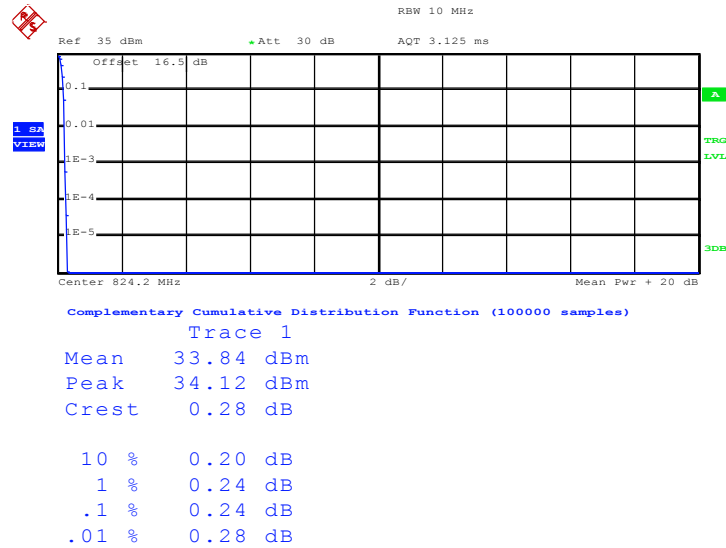

Date: 17.OCT.2014 19:38:55

#### Peak-to-Average Ratio on Channel 189 (836.4 MHz)

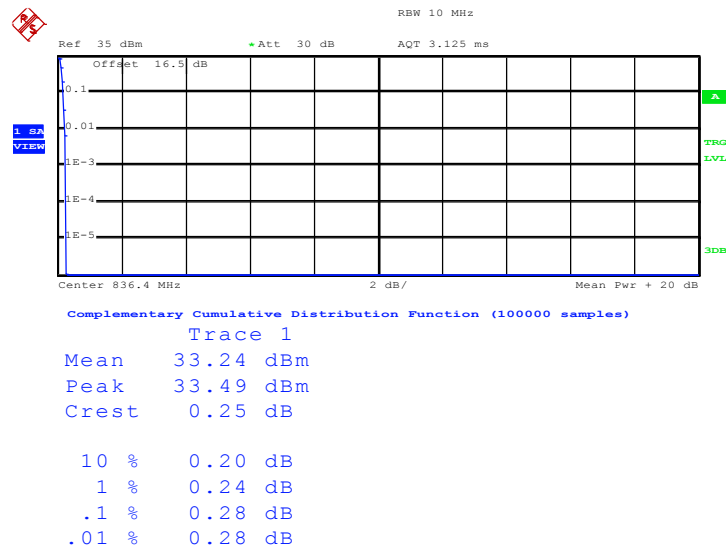

Date: 17.OCT.2014 19:39:59



Peak-to-Average Ratio on Channel 251 (848.8 MHz)

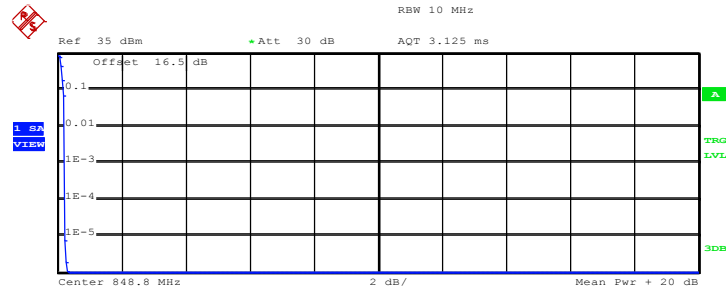

Complementary Cumulative Distribution Function (100000 samples)

Trace 1

Mean    33.48 dBm  
 Peak    33.77 dBm  
 Crest    0.29 dB

10 %    0.20 dB  
 1 %    0.24 dB  
 .1 %    0.24 dB  
 .01 %    0.24 dB

Date: 17.OCT.2014 19:41:24



<b>Band :</b>	GSM 850	<b>Test Mode :</b>	EDGE class 8 Link (8PSK)
---------------	---------	--------------------	--------------------------

**Peak-to-Average Ratio on Channel 128 (824.2 MHz)**

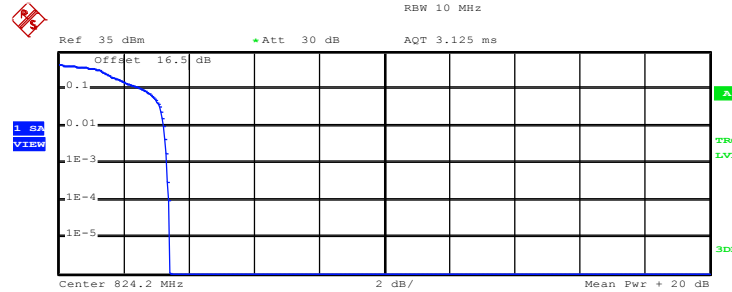

Complementary Cumulative Distribution Function (100000 samples)

Trace 1

Mean	27.10 dBm
Peak	30.53 dBm
Crest	3.43 dB
10 %	2.64 dB
1 %	3.24 dB
.1 %	3.36 dB
.01 %	3.40 dB

Date: 17.OCT.2014 20:09:39

**Peak-to-Average Ratio on Channel 189 (836.4 MHz)**

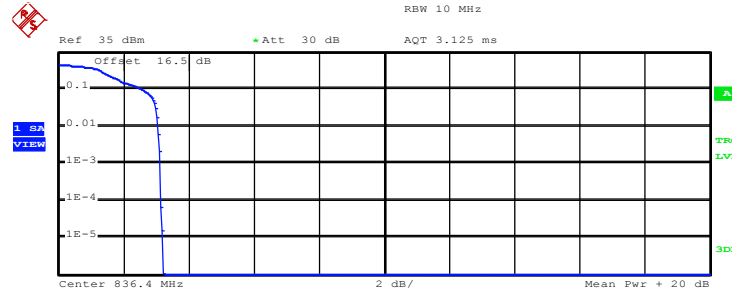

Complementary Cumulative Distribution Function (100000 samples)

Trace 1

Mean	27.46 dBm
Peak	30.67 dBm
Crest	3.21 dB
10 %	2.60 dB
1 %	3.08 dB
.1 %	3.16 dB
.01 %	3.16 dB

Date: 17.OCT.2014 20:10:44



Peak-to-Average Ratio on Channel 251 (848.8 MHz)

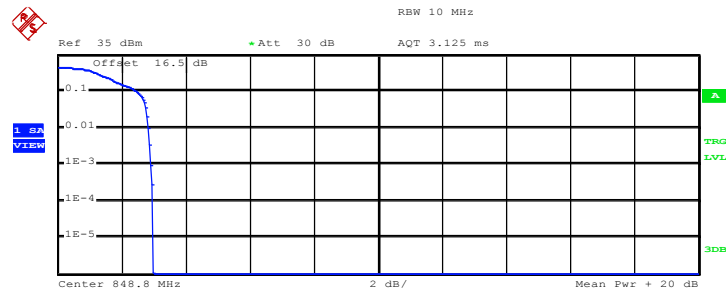

Complementary Cumulative Distribution Function (100000 samples)

Trace 1

Mean 27.46 dBm  
 Peak 30.46 dBm  
 Crest 2.99 dB

10 % 2.48 dB  
 1 % 2.84 dB  
 .1 % 2.92 dB  
 .01 % 3.00 dB

Date: 17.OCT.2014 20:12:04



<b>Band :</b>	GSM 1900	<b>Test Mode :</b>	GSM Link (GMSK)
---------------	----------	--------------------	-----------------

Peak-to-Average Ratio on Channel 512 (1850.2 MHz)

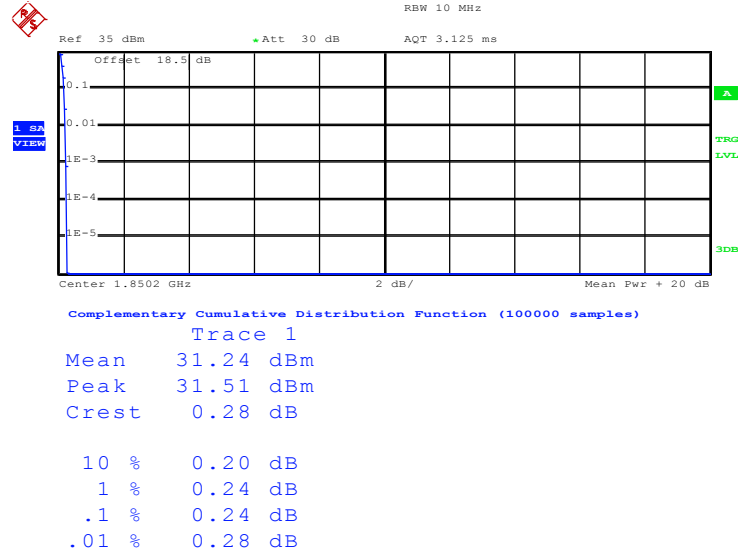

Date: 17.OCT.2014 21:14:28

Peak-to-Average Ratio on Channel 661 (1880.0 MHz)

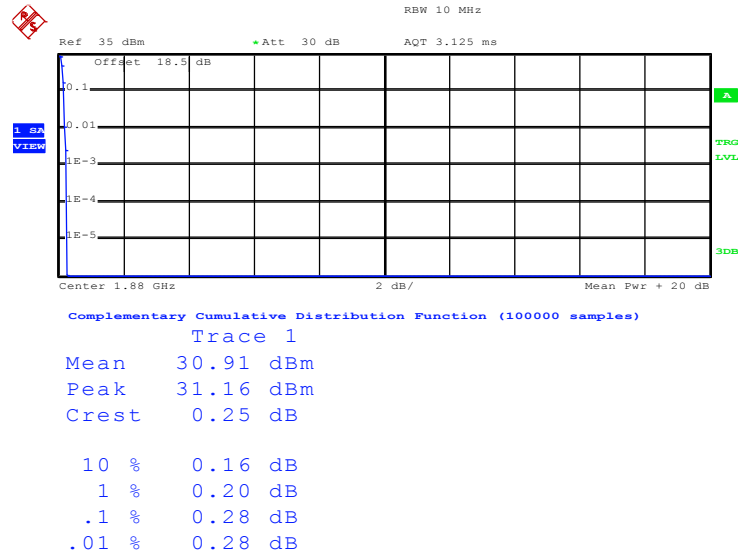

Date: 17.OCT.2014 21:20:27



Peak-to-Average Ratio on Channel 810 (1909.8 MHz)

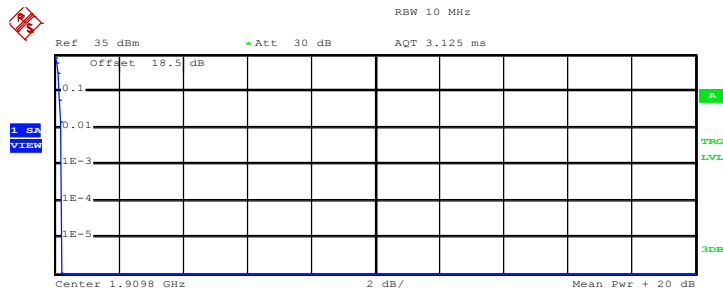

Complementary Cumulative Distribution Function (100000 samples)

Trace 1

Mean 31.84 dBm  
 Peak 32.08 dBm  
 Crest 0.23 dB

10 % 0.16 dB  
 1 % 0.20 dB  
 .1 % 0.24 dB  
 .01 % 0.24 dB

Date: 17.OCT.2014 21:18:33



<b>Band :</b>	GSM 1900	<b>Test Mode :</b>	EDGE class 8 Link (8PSK)
---------------	----------	--------------------	--------------------------

**Peak-to-Average Ratio on Channel 512 (1850.2 MHz)**

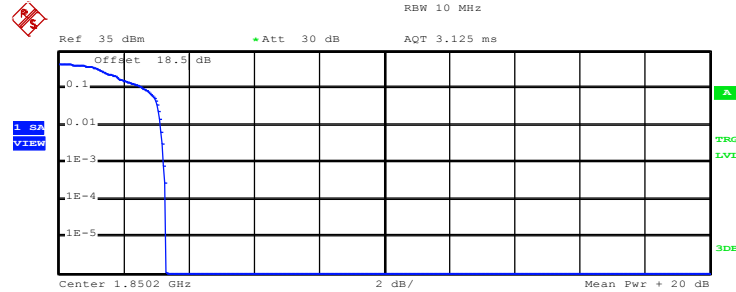

Complementary Cumulative Distribution Function (100000 samples)

Trace 1  
 Mean 26.38 dBm  
 Peak 29.68 dBm  
 Crest 3.30 dB

10 % 2.64 dB  
 1 % 3.16 dB  
 .1 % 3.24 dB  
 .01 % 3.32 dB

Date: 17.OCT.2014 21:59:30

**Peak-to-Average Ratio on Channel 661 (1880.0 MHz)**

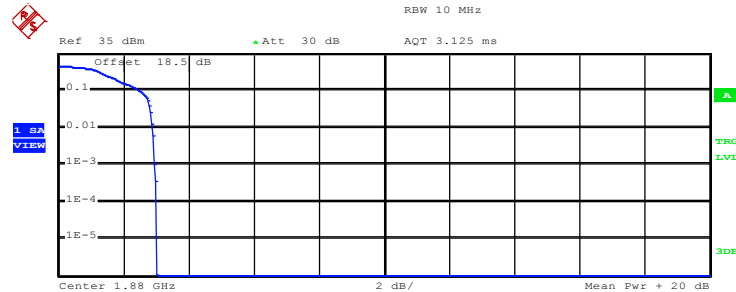

Complementary Cumulative Distribution Function (100000 samples)

Trace 1  
 Mean 26.73 dBm  
 Peak 29.75 dBm  
 Crest 3.02 dB

10 % 2.52 dB  
 1 % 2.88 dB  
 .1 % 2.96 dB  
 .01 % 3.04 dB

Date: 17.OCT.2014 22:01:37



Peak-to-Average Ratio on Channel 810 (1909.8 MHz)

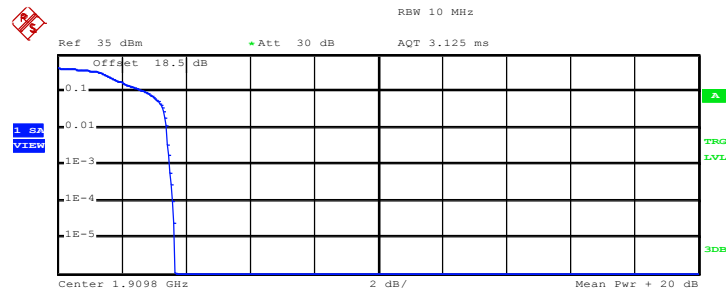

Complementary Cumulative Distribution Function (100000 samples)

Trace 1

Mean 26.24 dBm  
 Peak 29.89 dBm  
 Crest 3.65 dB

10 % 2.76 dB  
 1 % 3.40 dB  
 .1 % 3.52 dB  
 .01 % 3.60 dB

Date: 17.OCT.2014 22:02:45



<b>Band :</b>	WCDMA Band V	<b>Test Mode :</b>	RMC 12.2Kbps Link (QPSK)
---------------	--------------	--------------------	--------------------------

**Peak-to-Average Ratio on Channel 4132 (826.4 MHz)**

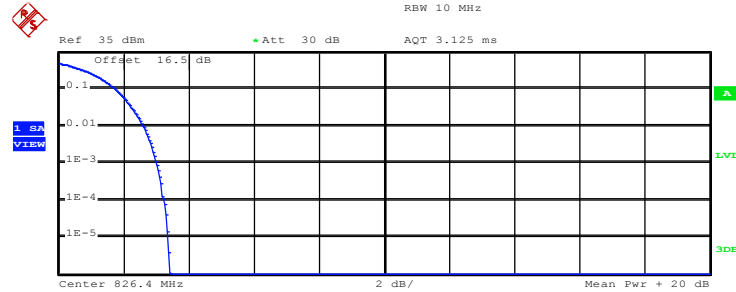

Complementary Cumulative Distribution Function (100000 samples)

Trace 1  
Mean 23.94 dBm  
Peak 27.35 dBm  
Crest 3.41 dB

10 %	1.76 dB
1 %	2.64 dB
.1 %	3.04 dB
.01 %	3.24 dB

Date: 17.OCT.2014 20:41:37

**Peak-to-Average Ratio on Channel 4182 (836.4 MHz)**

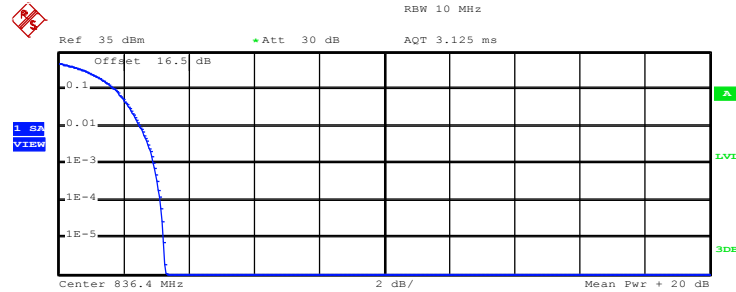

Complementary Cumulative Distribution Function (100000 samples)

Trace 1  
Mean 23.71 dBm  
Peak 27.00 dBm  
Crest 3.29 dB

10 %	1.76 dB
1 %	2.52 dB
.1 %	2.92 dB
.01 %	3.12 dB

Date: 17.OCT.2014 20:42:24



Peak-to-Average Ratio on Channel 4233 (846.6 MHz)

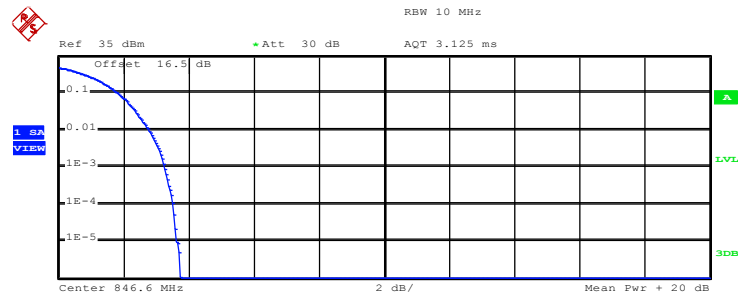

Complementary Cumulative Distribution Function (100000 samples)

Trace 1  
 Mean 23.74 dBm  
 Peak 27.49 dBm  
 Crest 3.75 dB

10 %	1.84 dB
1 %	2.80 dB
.1 %	3.28 dB
.01 %	3.52 dB

Date: 17.OCT.2014 20:43:08



<b>Band :</b>	WCDMA Band II	<b>Test Mode :</b>	RMC 12.2Kbps Link (QPSK)
---------------	---------------	--------------------	--------------------------

**Peak-to-Average Ratio on Channel 9262 (1852.4 MHz)**

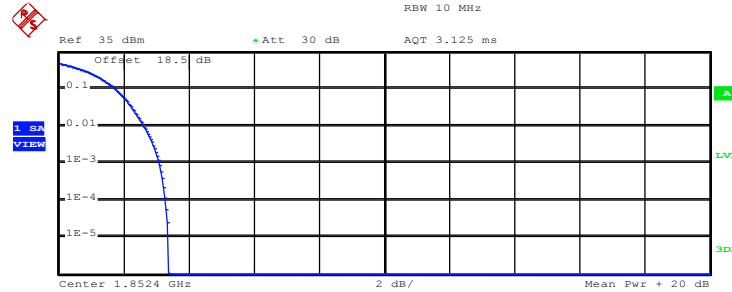

Complementary Cumulative Distribution Function (100000 samples)

Trace 1  
Mean    23.54 dBm  
Peak    26.93 dBm  
Crest    3.39 dB

10 %    1.76 dB  
1 %    2.64 dB  
.1 %    3.12 dB  
.01 %    3.28 dB

Date: 17.OCT.2014 22:25:14

**Peak-to-Average Ratio on Channel 9400 (1880.0 MHz)**

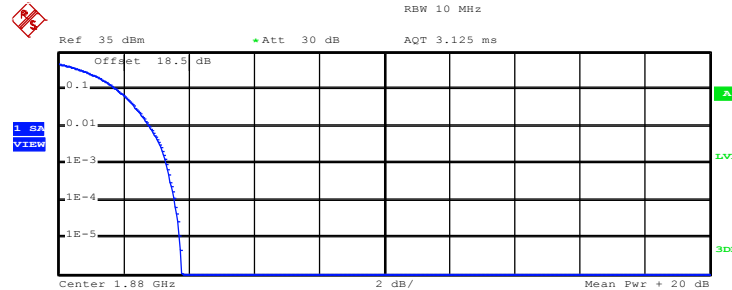

Complementary Cumulative Distribution Function (100000 samples)

Trace 1  
Mean    23.78 dBm  
Peak    27.56 dBm  
Crest    3.79 dB

10 %    1.80 dB  
1 %    2.80 dB  
.1 %    3.32 dB  
.01 %    3.56 dB

Date: 17.OCT.2014 22:26:05



Peak-to-Average Ratio on Channel 9538 (1907.6 MHz)

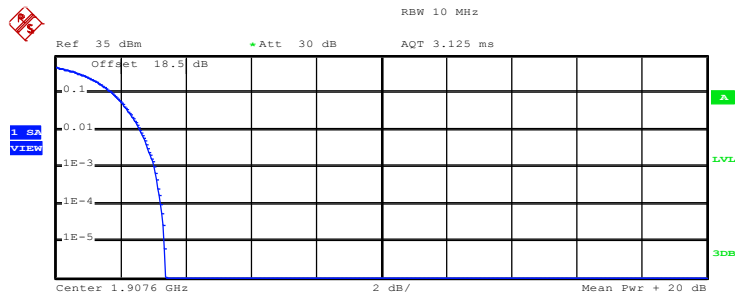

Complementary Cumulative Distribution Function (100000 samples)

Trace 1  
 Mean 23.63 dBm  
 Peak 27.00 dBm  
 Crest 3.37 dB

10 % 1.76 dB  
 1 % 2.60 dB  
 .1 % 3.04 dB  
 .01 % 3.24 dB

Date: 17.OCT.2014 22:27:10



### 3.3 Effective Radiated Power and Effective Isotropic Radiated Power Measurement

#### 3.3.1 Description of the ERP/EIRP Measurement

The substitution method, in ANSI / TIA / EIA-603-C-2004, was used for ERP/EIRP measurement, and the spectrum analyzer configuration follows KDB 971168 D01 Power Meas. License Digital Systems v02r02. The ERP of mobile transmitters must not exceed 7 Watts and the EIRP of mobile transmitters are limited to 2 Watts.

#### 3.3.2 Measuring Instruments

The measuring equipment is listed in the section 4 of this test report.

#### 3.3.3 Test Procedures

1. The testing follows FCC KDB 971168 v02r02 Section 5.2.1. (for CDMA/WCDMA), Section 5.2.2.2 (for GSM/GPRS/EDGE) and ANSI / TIA-603-C-2004 Section 2.2.17.
2. The EUT was placed on a non-conductive rotating platform 0.8 meters high in a semi-anechoic chamber. The radiated emission at the fundamental frequency was measured at 3 m with a test antenna and a spectrum analyzer with RMS detector per section 5. of KDB 971168 D01.
3. During the measurement, the system simulator parameters were set to force the EUT transmitting at maximum output power. The maximum emission was recorded from analyzer power level (LVL) from the 360 degrees rotation of the turntable and the test antenna raised and lowered over a range from 1 to 4 meters in both horizontally and vertically polarized orientations.
4. Effective Isotropic Radiated Power (EIRP) was measured by substitution method according to TIA/EIA-603-C. The EUT was replaced by dipole antenna (substitution antenna) at the same location, and then a known power from S.G. was applied into the dipole antenna through a Tx cable, and then recorded the maximum Analyzer reading through raised and lowered the test antenna. The correction factor (in dB) = S.G. - Tx Cable loss + Substitution antenna gain - Analyzer reading. Then the EUT's EIRP was calculated with the correction factor,  $EIRP = LVL + \text{Correction factor}$  and  $ERP = EIRP - 2.15$ .

### 3.3.4 Test Setup

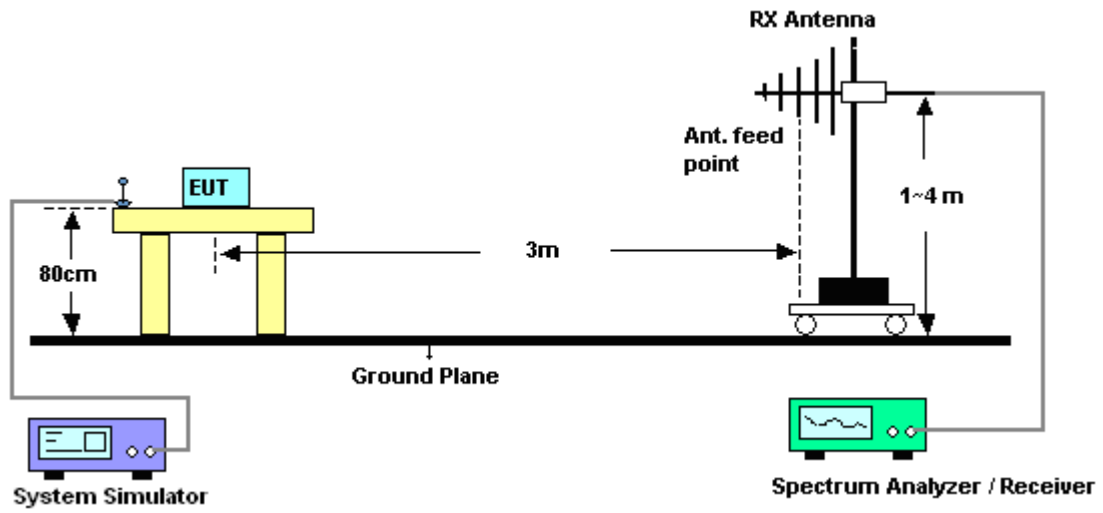



3.3.5 Test Result of ERP

GSM850 (GPRS class 8) Radiated Power ERP				
Horizontal Polarization				
Frequency (MHz)	LVL (dBm)	Correction Factor (dB)	ERP (dBm)	ERP (W)
824.2	-0.87	31.54	28.52	0.71
836.4	-0.16	32.04	29.73	0.94
848.8	-0.39	32.59	30.05	1.01
Vertical Polarization				
Frequency (MHz)	LVL (dBm)	Correction Factor (dB)	ERP (dBm)	ERP (W)
824.2	-8.56	32.93	22.22	0.17
836.4	-8.38	32.82	22.29	0.17
848.8	-8.91	33.62	22.56	0.18

\* ERP = LVL (dBm) + Correction Factor (dB) – 2.15

GSM850 (EDGE class 8) Radiated Power ERP				
Horizontal Polarization				
Frequency (MHz)	LVL (dBm)	Correction Factor (dB)	ERP (dBm)	ERP (W)
824.2	-7.76	31.54	21.63	0.15
836.4	-7.77	32.04	22.12	0.16
848.8	-7.50	32.59	22.94	0.20
Vertical Polarization				
Frequency (MHz)	LVL (dBm)	Correction Factor (dB)	ERP (dBm)	ERP (W)
824.2	-16.43	32.93	14.35	0.03
836.4	-15.78	32.82	14.89	0.03
848.8	-15.81	33.62	15.66	0.04

\* ERP = LVL (dBm) + Correction Factor (dB) – 2.15



WCDMA Band V (RMC 12.2Kbps) Radiated Power ERP				
Horizontal Polarization				
Frequency (MHz)	LVL (dBm)	Correction Factor (dB)	ERP (dBm)	ERP (W)
826.40	-10.74	31.44	18.55	0.07
836.40	-10.59	32.04	19.30	0.09
846.60	-10.61	32.63	19.87	0.10
Vertical Polarization				
Frequency (MHz)	LVL (dBm)	Correction Factor (dB)	ERP (dBm)	ERP (W)
826.40	-18.98	32.78	11.65	0.01
836.40	-18.45	32.82	12.22	0.02
846.60	-18.61	33.40	12.64	0.02

\* ERP = LVL (dBm) + Correction Factor (dB) – 2.15



3.3.6 Test Result of EIRP

GSM1900 (GSM) Radiated Power EIRP				
Horizontal Polarization				
Frequency (MHz)	LVL (dBm)	Correction Factor (dB)	EIRP (dBm)	EIRP (W)
1850.2	-12.68	45.34	32.66	1.85
1880.0	-13.18	46.01	32.83	1.92
1909.8	-13.21	45.81	32.60	1.82
Vertical Polarization				
Frequency (MHz)	LVL (dBm)	Correction Factor (dB)	EIRP (dBm)	EIRP (W)
1850.2	-18.38	49.22	30.84	1.21
1880.0	-18.80	50.42	31.62	1.45
1909.8	-19.44	49.00	29.56	0.90

\* EIRP = LVL (dBm) + Correction Factor (dB)

GSM1900 (EDGE class 8) Radiated Power EIRP				
Horizontal Polarization				
Frequency (MHz)	LVL (dBm)	Correction Factor (dB)	EIRP (dBm)	EIRP (W)
1850.2	-19.26	45.34	26.08	0.41
1880.0	-19.37	46.01	26.64	0.46
1909.8	-18.77	45.81	27.04	0.51
Vertical Polarization				
Frequency (MHz)	LVL (dBm)	Correction Factor (dB)	EIRP (dBm)	EIRP (W)
1850.2	-26.40	49.22	22.82	0.19
1880.0	-27.30	50.42	23.12	0.21
1909.8	-25.12	49.00	23.88	0.24

\* EIRP = LVL (dBm) + Correction Factor (dB)



WCDMA Band II (RMC 12.2Kbps) Radiated Power EIRP				
Horizontal Polarization				
Frequency (MHz)	LVL (dBm)	Correction Factor (dB)	EIRP (dBm)	EIRP (W)
1852.40	-20.34	45.37	25.03	0.32
1880.00	-20.72	46.01	25.29	0.34
1907.60	-20.55	45.87	25.32	0.34
Vertical Polarization				
Frequency (MHz)	LVL (dBm)	Correction Factor (dB)	EIRP (dBm)	EIRP (W)
1852.40	-25.25	49.23	23.98	0.25
1880.00	-26.08	50.42	24.34	0.27
1907.60	-24.88	49.04	24.16	0.26

\* EIRP = LVL (dBm) + Correction Factor (dB)

### 3.4 99% Occupied Bandwidth and 26dB Bandwidth Measurement

#### 3.4.1 Description of 99% Occupied Bandwidth and 26dB Bandwidth Measurement

The 99% occupied bandwidth is the width of a frequency band such that, below the lower and above the upper frequency limits, the mean powers emitted are each equal to a specified percentage 0.5% of the total mean transmitted power.

The emission bandwidth is defined as the width of the signal between two points, located at the 2 sides of the carrier frequency, outside of which all emissions are attenuated at least 26 dB below the transmitter power.

#### 3.4.2 Measuring Instruments

The measuring equipment is listed in the section 4 of this test report.

#### 3.4.3 Test Procedures

1. The testing follows FCC KDB 971168 v02r02 Section 4.2.
2. The EUT was connected to the spectrum analyzer and system simulator via a power divider.
3. The RF output of the EUT was connected to the spectrum analyzer by RF cable and attenuator. The path loss was compensated to the results for each measurement.
4. The 99% occupied bandwidth were measured, set RBW= 1% of span, VBW= 3\*RBW, sample detector, trace maximum hold.
5. The 26dB bandwidth were measured, set RBW= 1% of EBW, VBW= 3\*RBW, peak detector, trace maximum hold.

#### 3.4.4 Test Setup

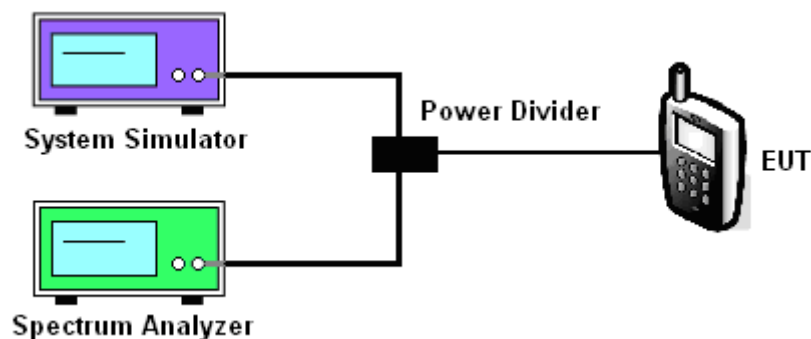



3.4.5 Test Result of Occupied Bandwidth and 26dB Bandwidth

Cellular Band						
Modes	GSM850 (GPRS class 8)			GSM850 (EDGE class 8)		
Channel	128 (Low)	189 (Mid)	251 (High)	128 (Low)	189 (Mid)	251 (High)
Frequency (MHz)	824.2	836.4	848.8	824.2	836.4	848.8
99% OBW (kHz)	244.00	248.00	244.00	244.00	248.00	242.00
26dB BW (kHz)	314.00	316.00	310.00	306.00	306.00	310.00

PCS Band						
Modes	GSM1900 (GSM)			GSM1900 (EDGE class 8)		
Channel	512 (Low)	661 (Mid)	810 (High)	512 (Low)	661 (Mid)	810 (High)
Frequency (MHz)	1850.2	1880	1909.8	1850.2	1880	1909.8
99% OBW (kHz)	246.00	244.00	248.00	246.00	248.00	248.00
26dB BW (kHz)	314.00	314.00	312.00	306.00	306.00	296.00

Cellular Band			
Modes	WCDMA Band V (RMC 12.2Kbps)		
Channel	4132 (Low)	4182 (Mid)	4233 (High)
Frequency (MHz)	826.4	836.4	846.6
99% OBW (MHz)	4.14	4.18	4.18
26dB BW (MHz)	4.68	4.68	4.68

PCS Band			
Modes	WCDMA Band II (RMC 12.2Kbps)		
Channel	9262 (Low)	9400 (Mid)	9538 (High)
Frequency (MHz)	1852.4	1880	1907.6
99% OBW (MHz)	4.18	4.16	4.16
26dB BW (MHz)	4.68	4.66	4.66



### 3.4.6 Test Result (Plots) of Occupied Bandwidth and 26dB Bandwidth

<b>Band :</b>	GSM 850	<b>Test Mode :</b>	GPRS class 8 Link (GMSK)
---------------	---------	--------------------	--------------------------

#### 99% Occupied Bandwidth Plot on Channel 128 (824.2 MHz)

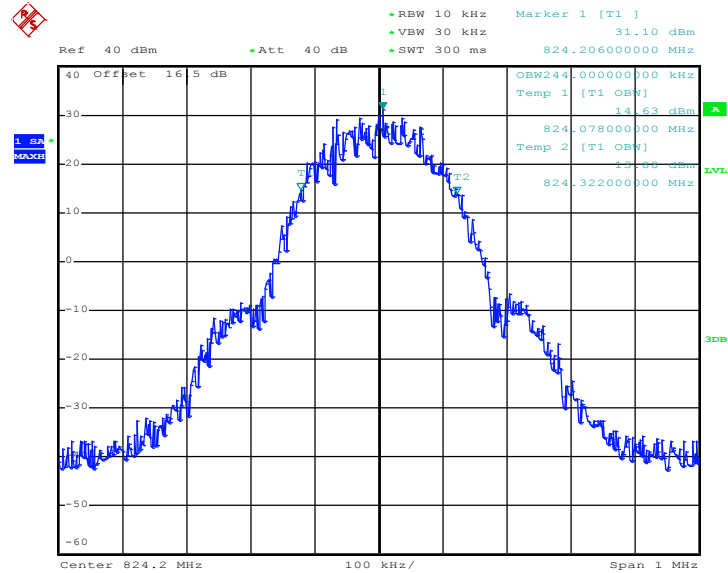

Date: 17.OCT.2014 19:09:31

#### 26dB Bandwidth Plot on Channel 128 (824.2 MHz)

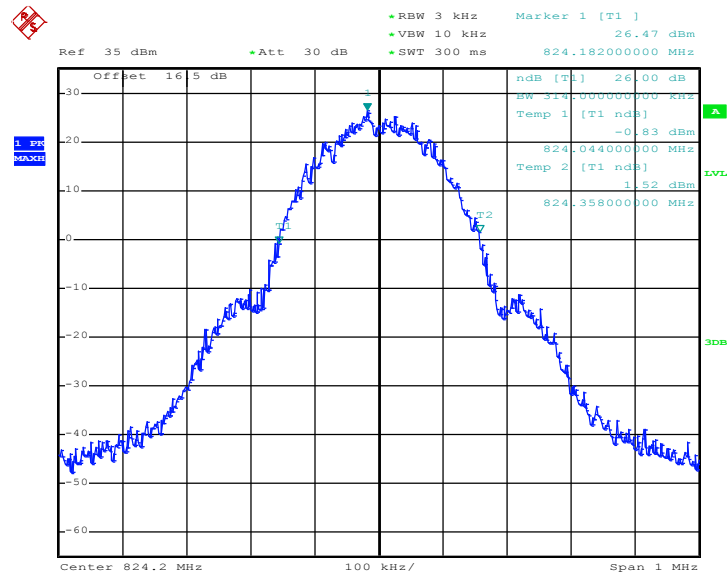

Date: 17.OCT.2014 18:55:04



99% Occupied Bandwidth Plot on Channel 189 (836.4 MHz)

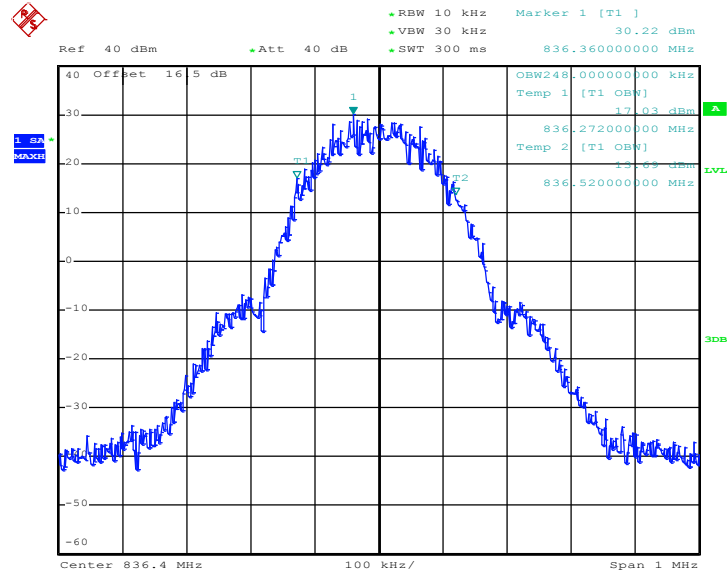

Date: 17.OCT.2014 19:10:07

26dB Bandwidth Plot on Channel 189 (836.4 MHz)

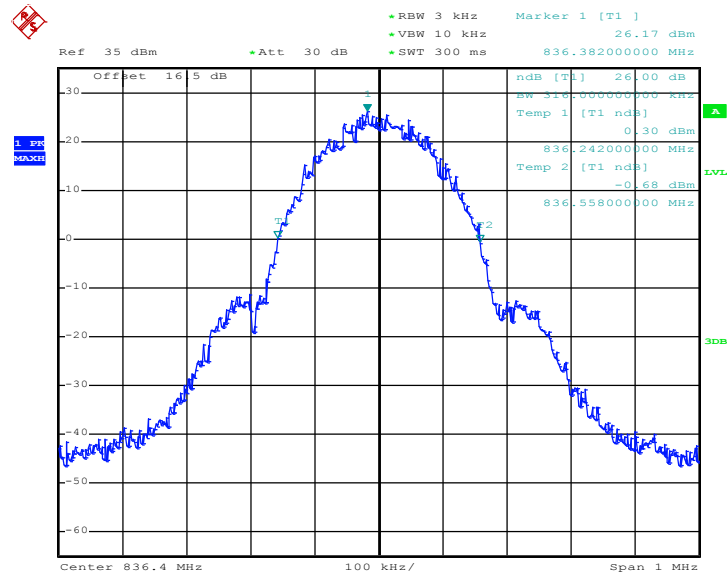

Date: 17.OCT.2014 18:55:41



99% Occupied Bandwidth Plot on Channel 251 (848.8 MHz)

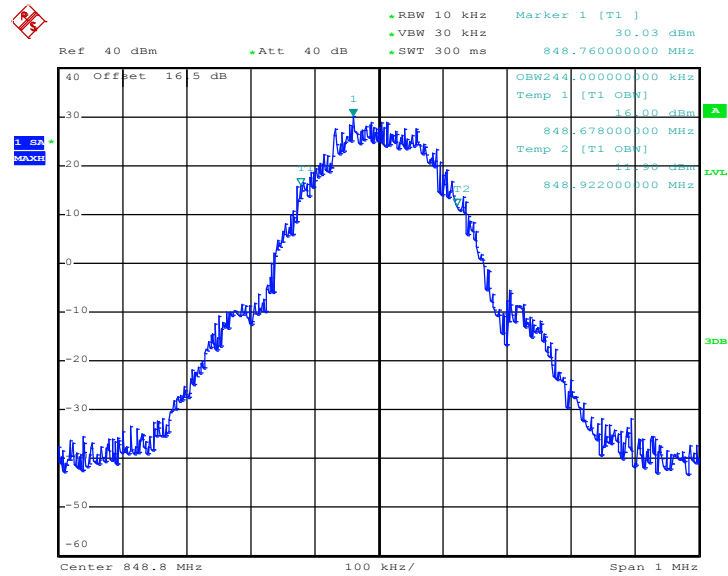

Date: 17.OCT.2014 19:10:43

26dB Bandwidth Plot on Channel 251 (848.8 MHz)

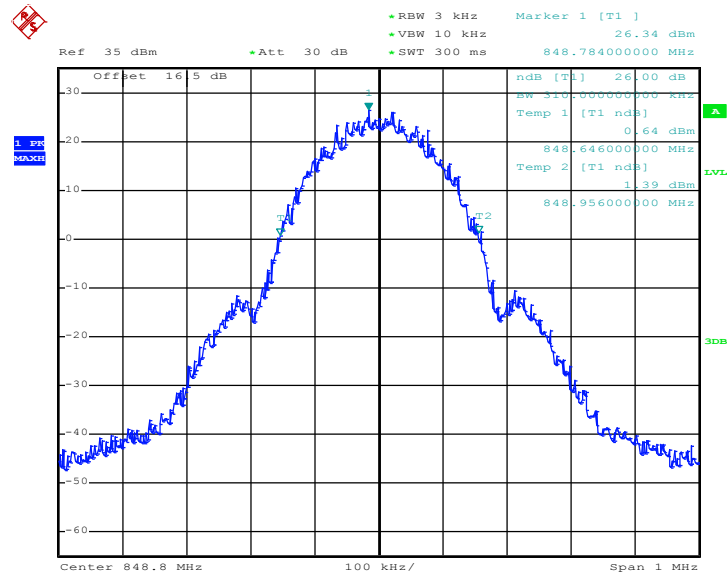

Date: 17.OCT.2014 18:56:18



<b>Band :</b>	GSM 850	<b>Test Mode :</b>	EDGE class 8 Link (8PSK)
---------------	---------	--------------------	--------------------------

99% Occupied Bandwidth Plot on Channel 128 (824.2 MHz)

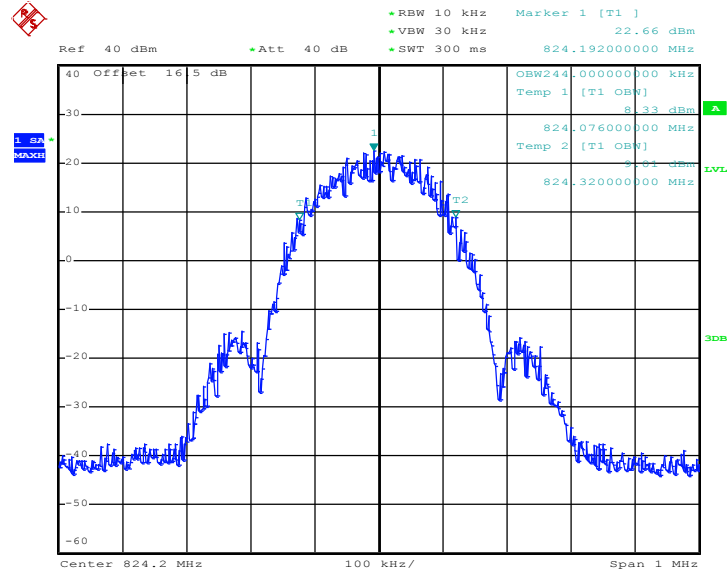

Date: 17.OCT.2014 19:49:17

26dB Bandwidth Plot on Channel 128 (824.2 MHz)

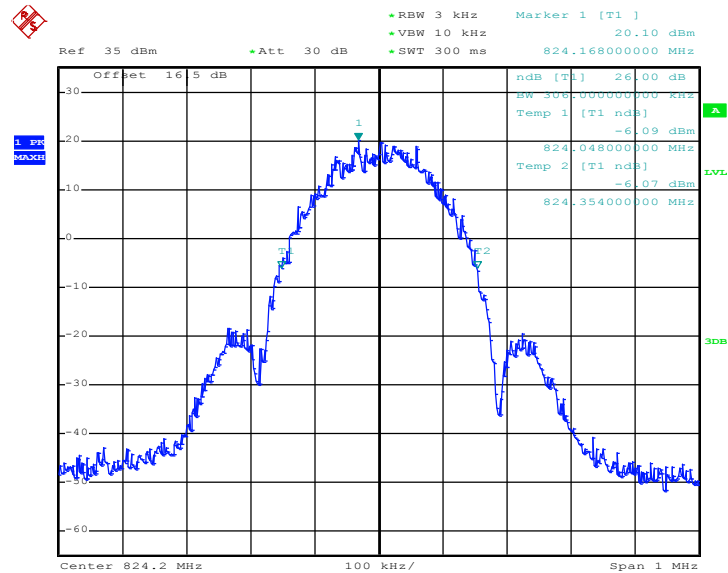

Date: 17.OCT.2014 19:44:55



### 99% Occupied Bandwidth Plot on Channel 189 (836.4 MHz)

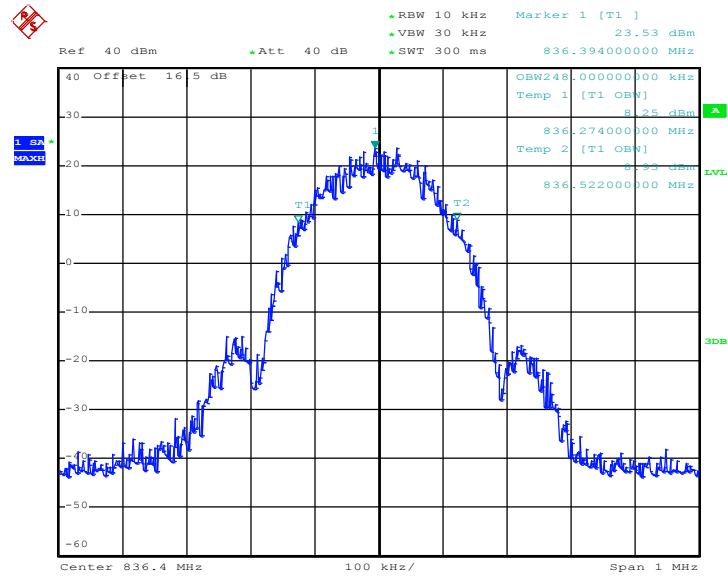

Date: 17.OCT.2014 19:49:55

### 26dB Bandwidth Plot on Channel 189 (836.4 MHz)

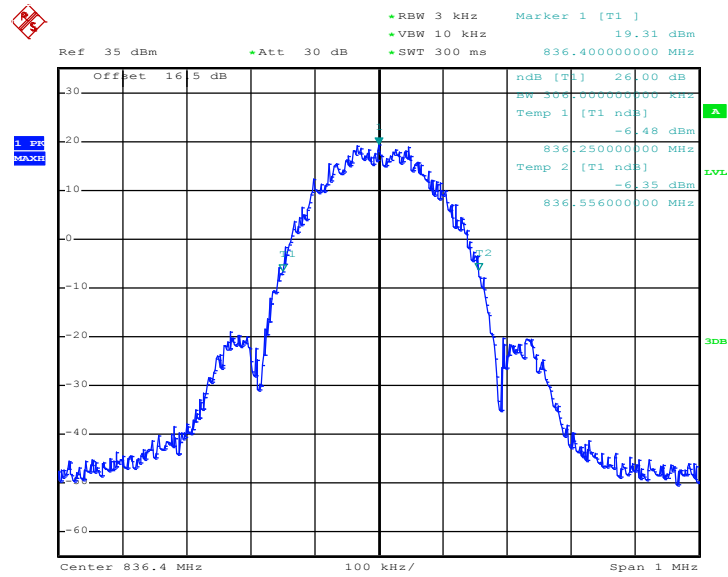

Date: 17.OCT.2014 19:45:30



### 99% Occupied Bandwidth Plot on Channel 251 (848.8 MHz)

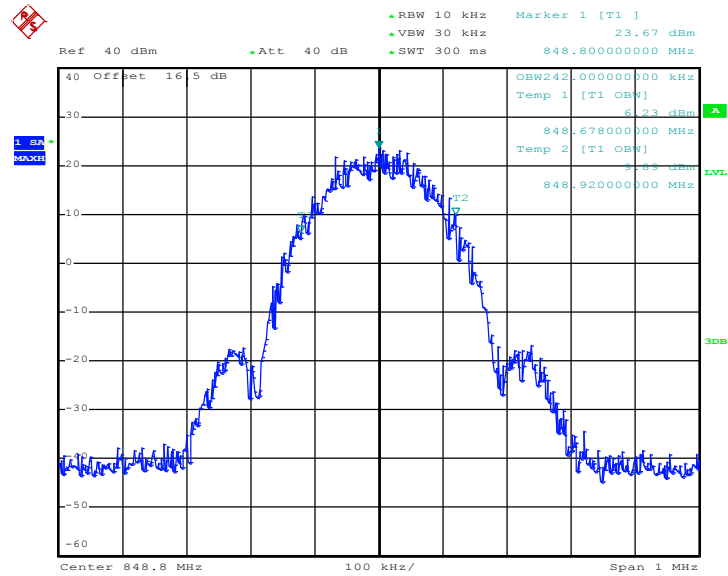

Date: 17.OCT.2014 19:50:30

### 26dB Bandwidth Plot on Channel 251 (848.8 MHz)

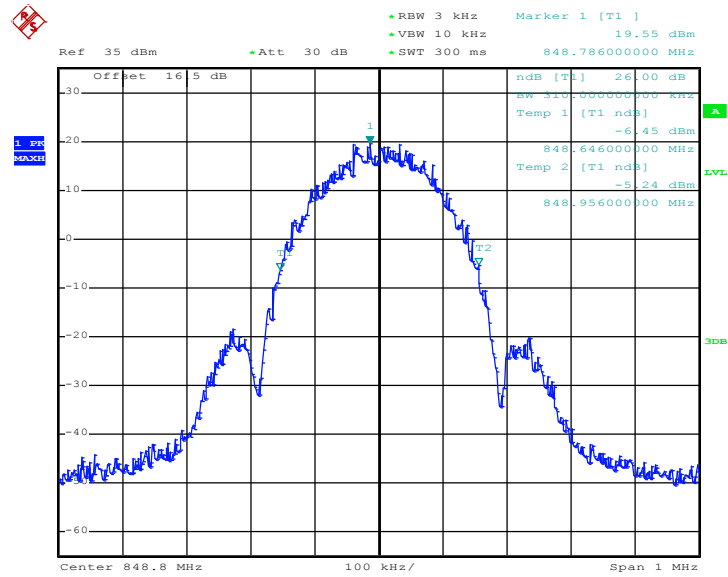

Date: 17.OCT.2014 19:46:06



Band :	GSM 1900	Test Mode :	GSM Link (GMSK)
--------	----------	-------------	-----------------

99% Occupied Bandwidth Plot on Channel 512 (1850.2 MHz)

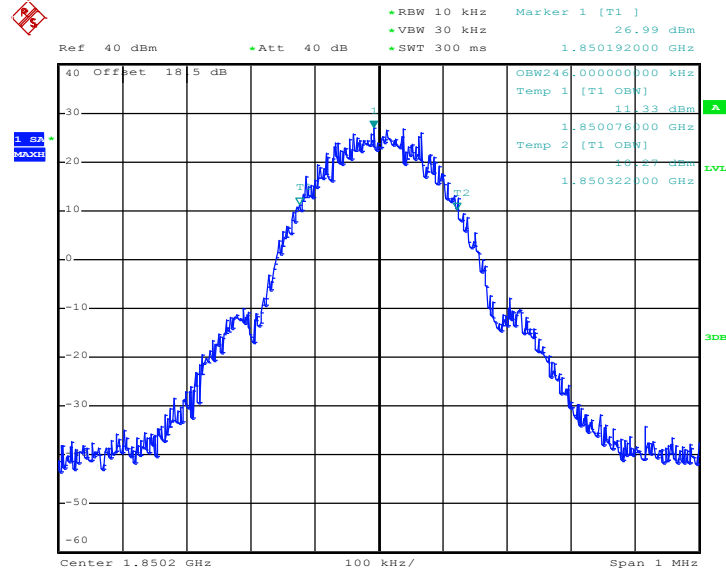

Date: 17.OCT.2014 20:51:46

26dB Bandwidth Plot on Channel 512 (1850.2 MHz)

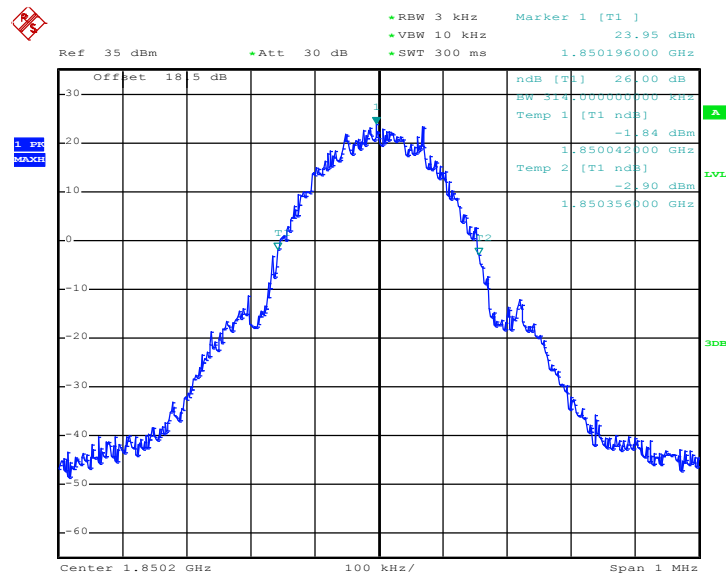

Date: 17.OCT.2014 20:49:46



### 99% Occupied Bandwidth Plot on Channel 661 (1880.0 MHz)

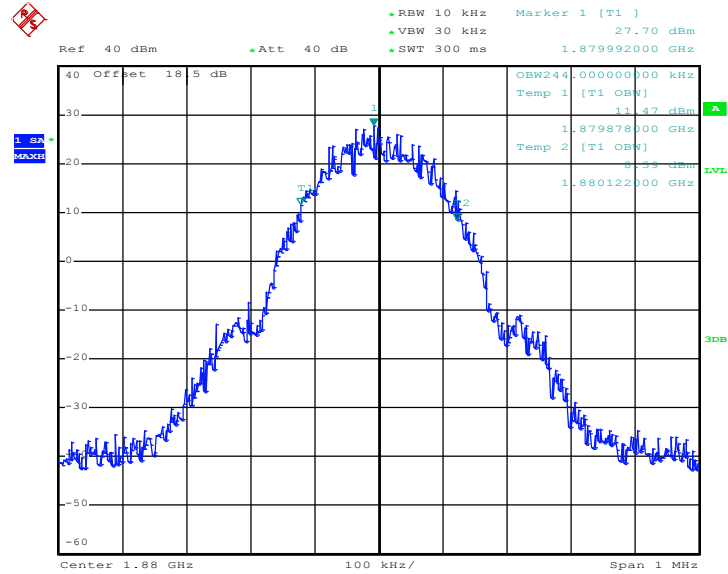

Date: 17.OCT.2014 20:52:21

### 26dB Bandwidth Plot on Channel 661 (1880.0 MHz)

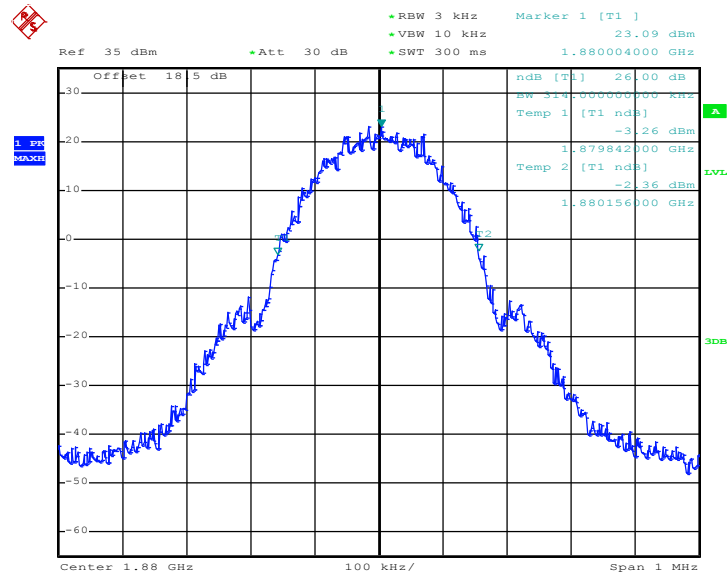

Date: 17.OCT.2014 20:50:23



99% Occupied Bandwidth Plot on Channel 810 (1909.8 MHz)

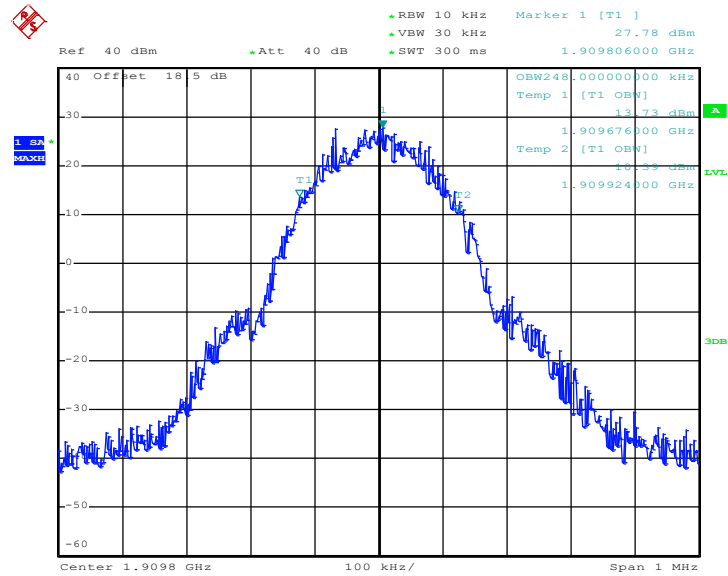

Date: 17.OCT.2014 20:52:59

26dB Bandwidth Plot on Channel 810 (1909.8 MHz)

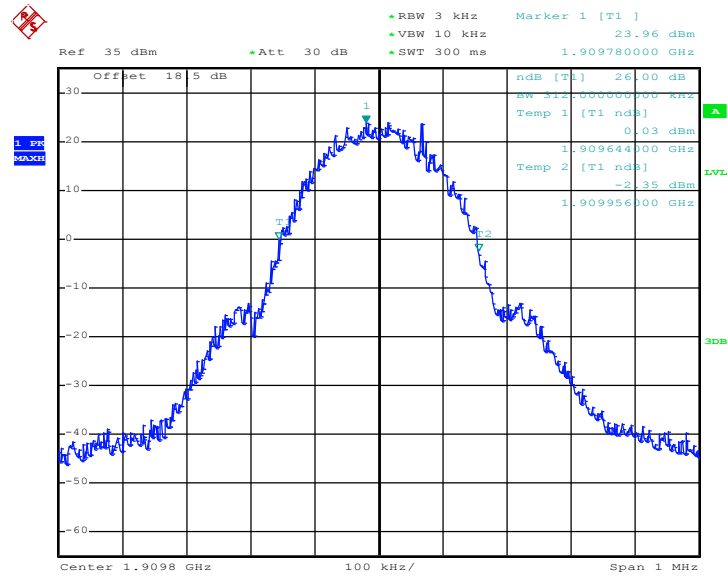

Date: 17.OCT.2014 20:50:57



<b>Band :</b>	GSM 1900	<b>Test Mode :</b>	EDGE class 8 Link (8PSK)
---------------	----------	--------------------	--------------------------

99% Occupied Bandwidth Plot on Channel 512 (1850.2 MHz)

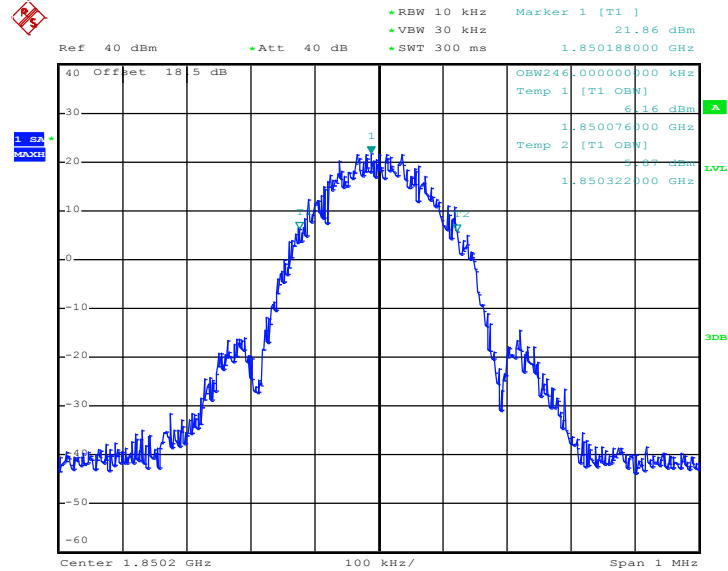

Date: 17.OCT.2014 21:31:18

26dB Bandwidth Plot on Channel 512 (1850.2 MHz)

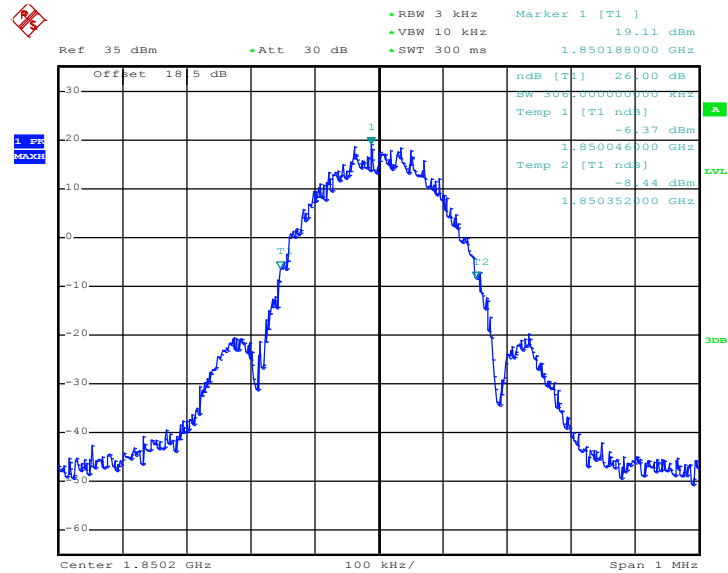

Date: 17.OCT.2014 21:28:58



### 99% Occupied Bandwidth Plot on Channel 661 (1880.0 MHz)

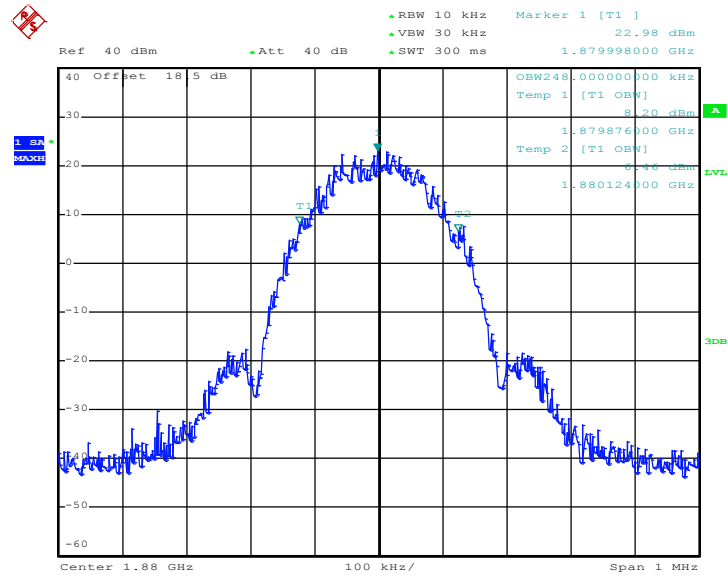

Date: 17.OCT.2014 21:32:02

### 26dB Bandwidth Plot on Channel 661 (1880.0 MHz)

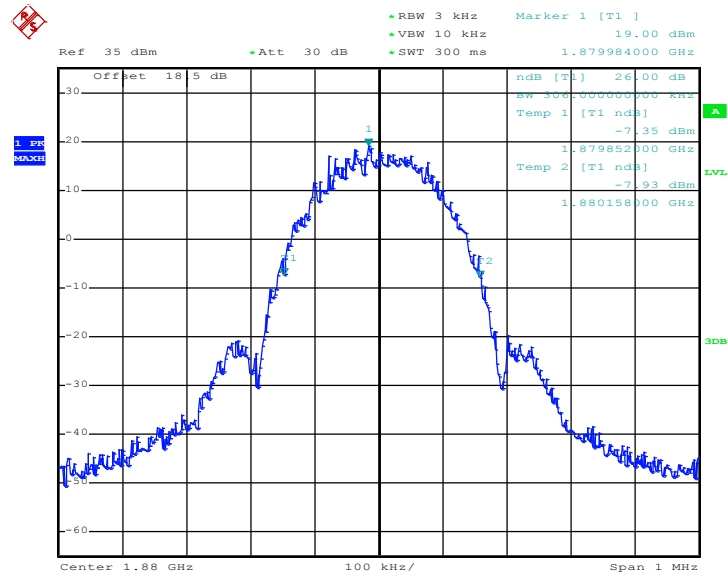

Date: 17.OCT.2014 21:29:34



### 99% Occupied Bandwidth Plot on Channel 810 (1909.8 MHz)

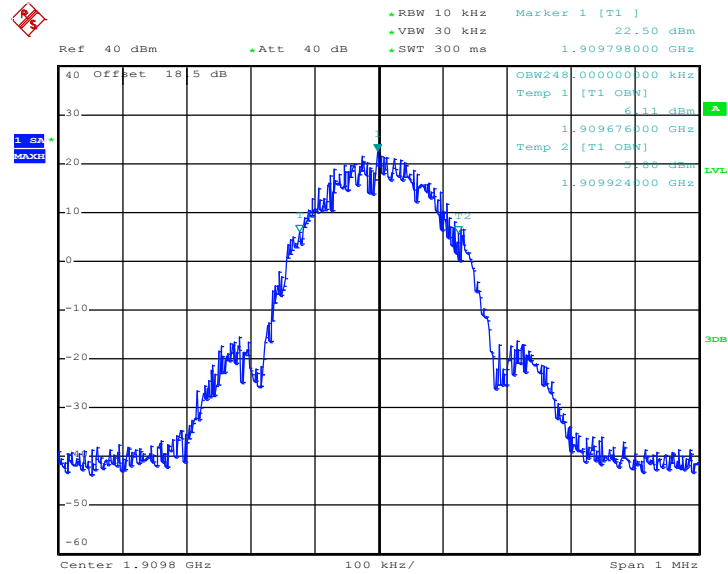

Date: 17.OCT.2014 21:32:37

### 26dB Bandwidth Plot on Channel 810 (1909.8 MHz)

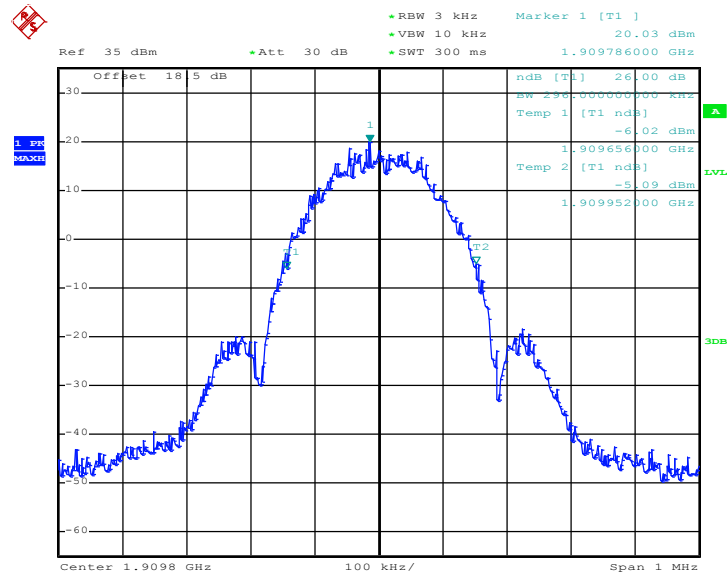

Date: 17.OCT.2014 21:30:12



Band :	WCDMA Band V	Test Mode :	RMC 12.2Kbps Link (QPSK)
--------	--------------	-------------	--------------------------

99% Occupied Bandwidth Plot on Channel 4132 (826.4 MHz)

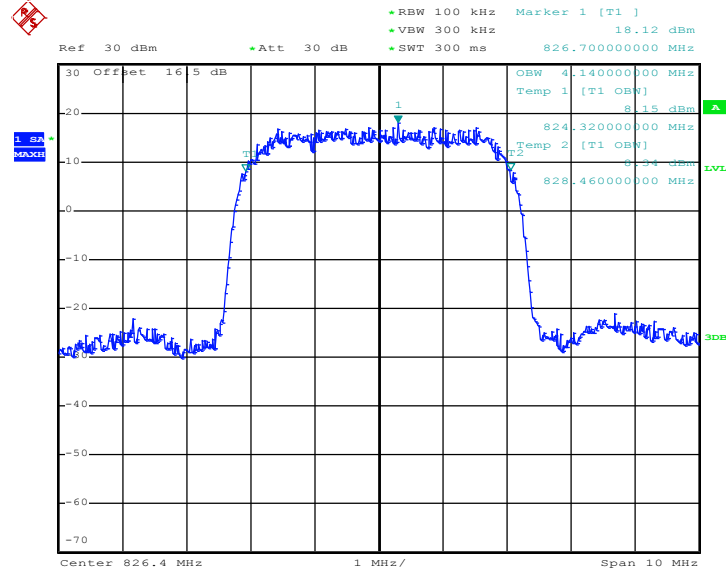

Date: 17.OCT.2014 20:22:59

26dB Bandwidth Plot on Channel 4132 (826.4 MHz)

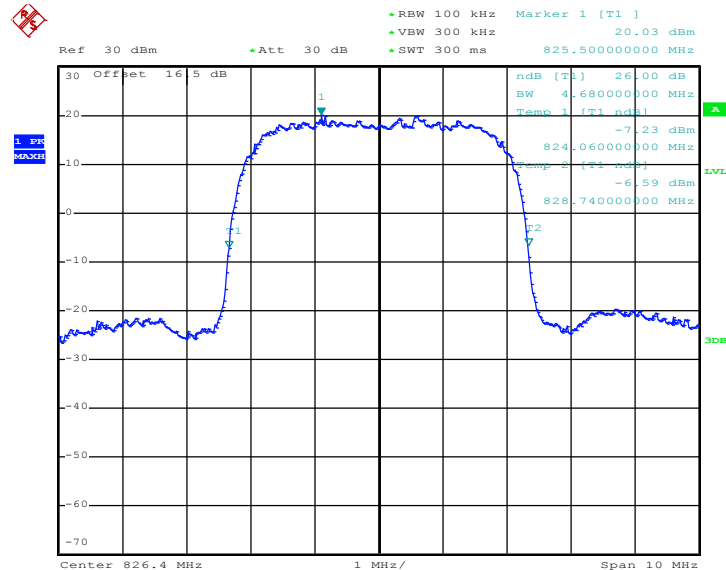

Date: 17.OCT.2014 20:20:51



### 99% Occupied Bandwidth Plot on Channel 4182 (836.4 MHz)

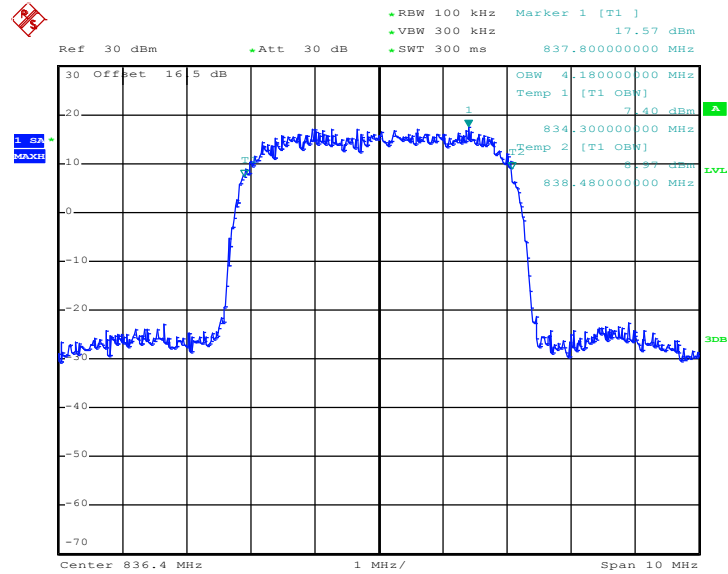

Date: 17.OCT.2014 20:23:44

### 26dB Bandwidth Plot on Channel 4182 (836.4 MHz)

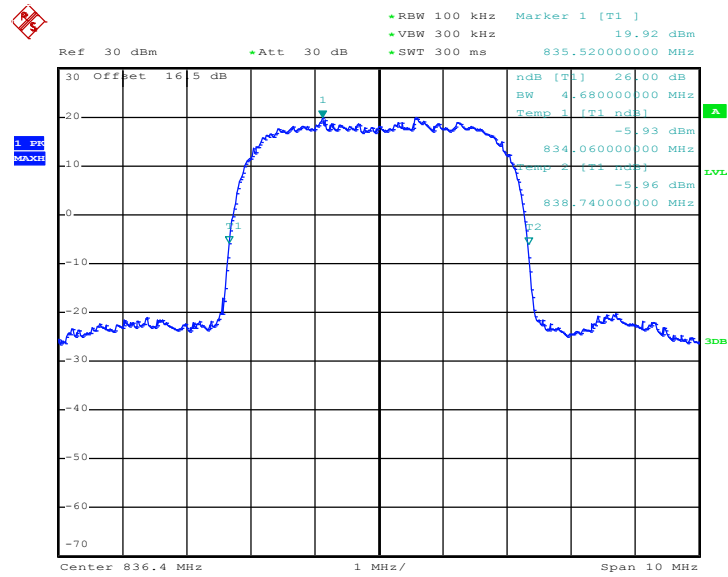

Date: 17.OCT.2014 20:21:26



### 99% Occupied Bandwidth Plot on Channel 4233 (846.6 MHz)

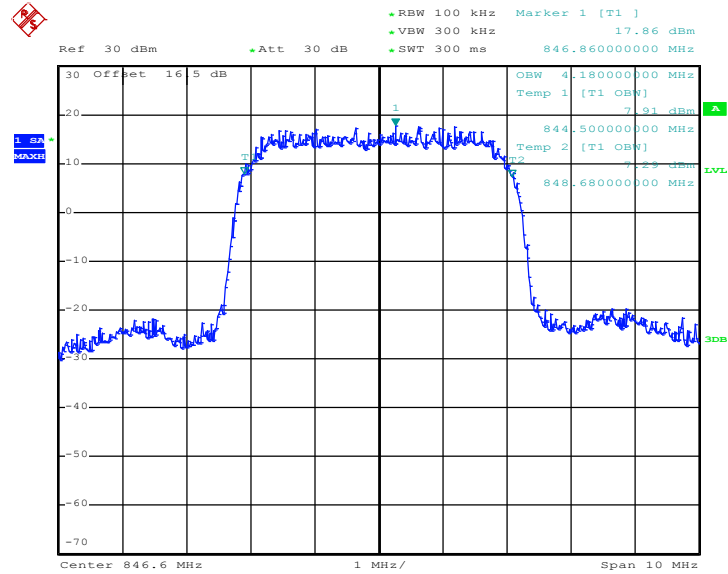

Date: 17.OCT.2014 20:24:19

### 26dB Bandwidth Plot on Channel 4233 (846.6 MHz)

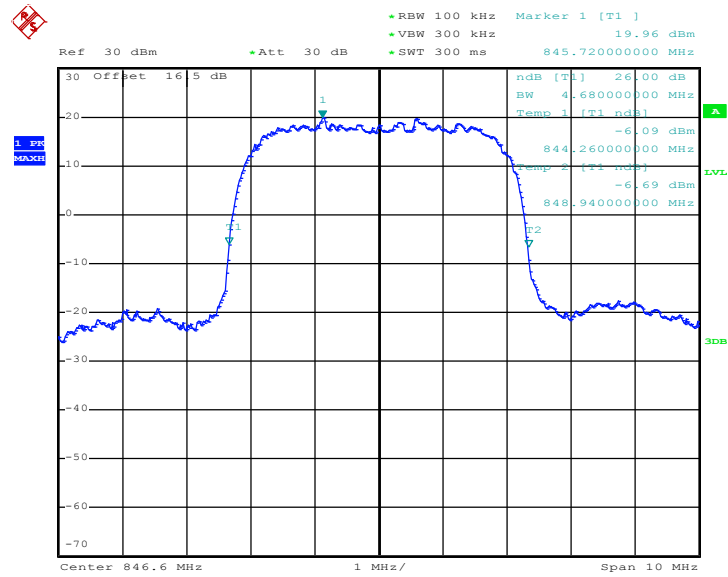

Date: 17.OCT.2014 20:22:04



Band :	WCDMA Band II	Test Mode :	RMC 12.2Kbps Link (QPSK)
--------	---------------	-------------	--------------------------

99% Occupied Bandwidth Plot on Channel 9262 (1852.4 MHz)

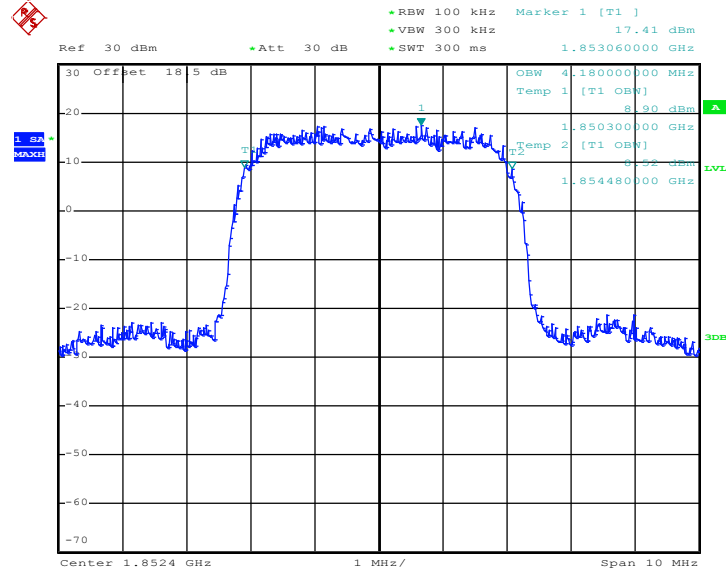

Date: 17.OCT.2014 22:10:12

26dB Bandwidth Plot on Channel 9262 (1852.4 MHz)

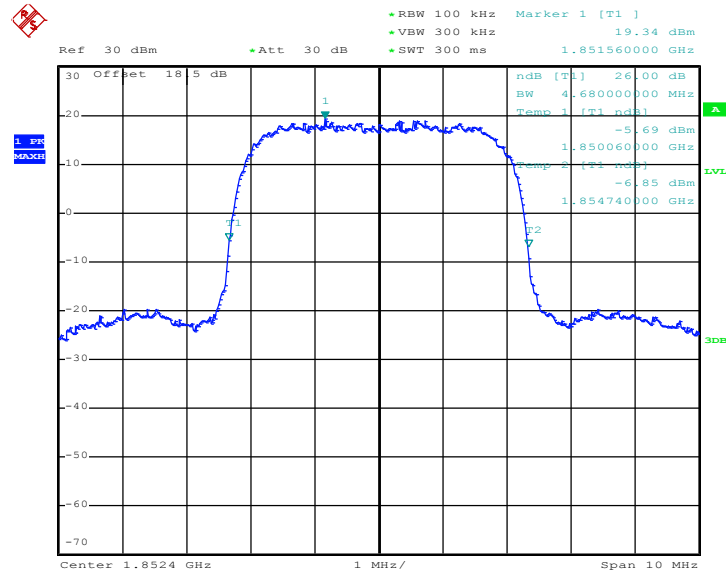

Date: 17.OCT.2014 22:07:58



### 99% Occupied Bandwidth Plot on Channel 9400 (1880.0 MHz)

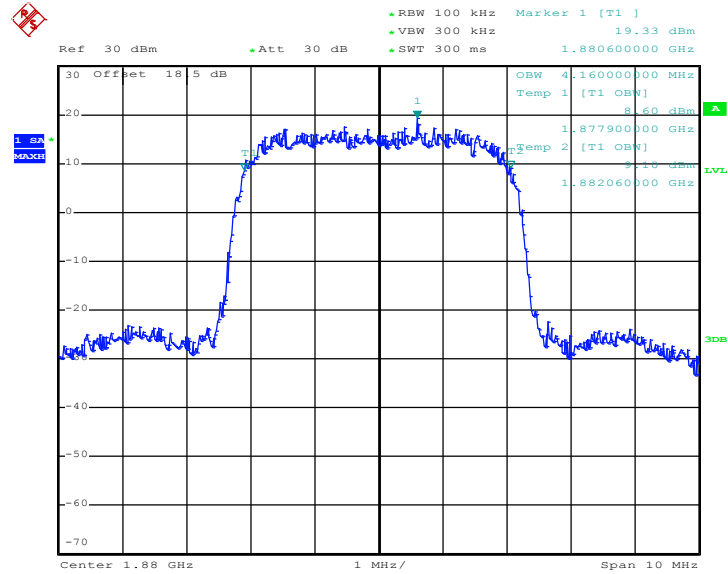

Date: 17.OCT.2014 22:10:48

### 26dB Bandwidth Plot on Channel 9400 (1880.0 MHz)

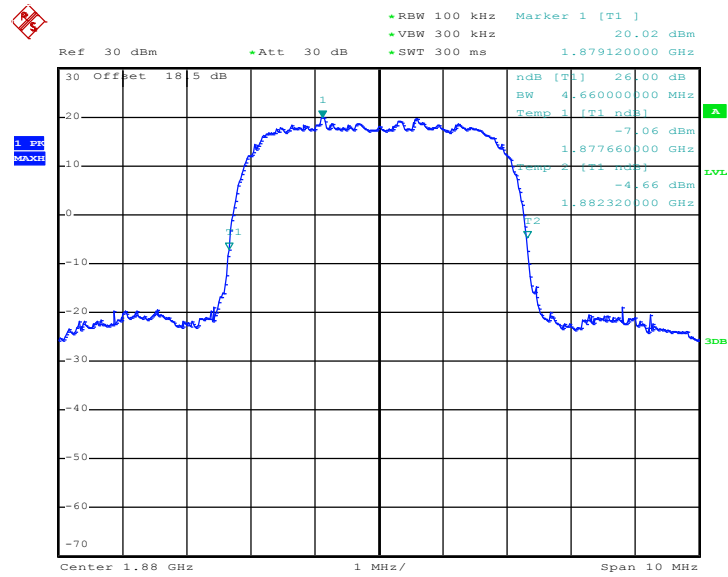

Date: 17.OCT.2014 22:08:41



99% Occupied Bandwidth Plot on Channel 9538 (1907.6 MHz)

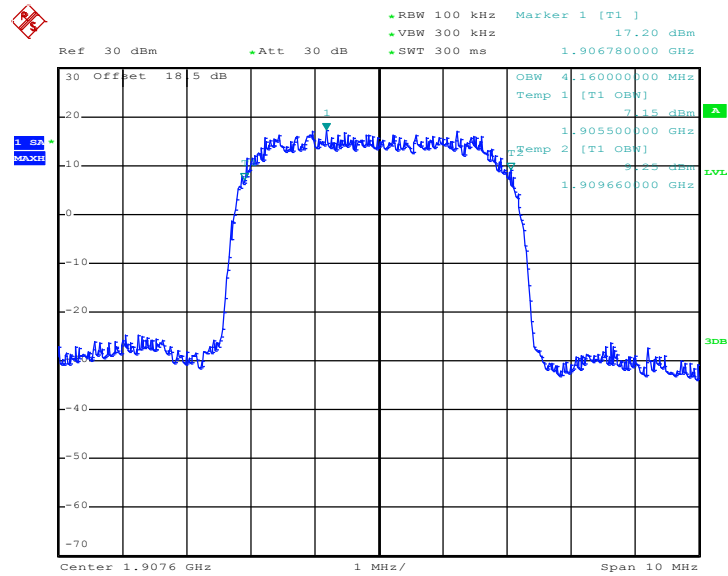

Date: 17.OCT.2014 22:11:28

26dB Bandwidth Plot on Channel 9538 (1907.6 MHz)

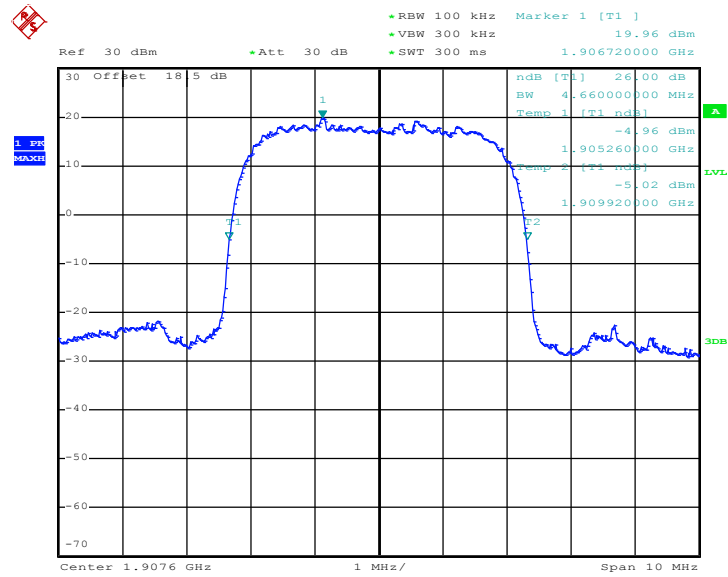

Date: 17.OCT.2014 22:09:23

## 3.5 Band Edge Measurement

### 3.5.1 Description of Band Edge Measurement

The power of any emission outside of the authorized operating frequency ranges must be lower than the transmitter power (P) by a factor of at least  $43 + 10 \log (P)$  dB.

### 3.5.2 Measuring Instruments

The measuring equipment is listed in the section 4 of this test report.

### 3.5.3 Test Procedures

1. The testing follows FCC KDB 971168 v02r02 Section 6.0.
2. The EUT was connected to the spectrum analyzer and system simulator via a power divider.
3. The RF output of EUT was connected to the spectrum analyzer by an RF cable and attenuator. The path loss was compensated to the results for each measurement.
4. The band edges of low and high channels for the highest RF powers were measured.
5. The RF fundamental frequency should be excluded against the limit line in the operating frequency band.
6. The limit line is derived from  $43 + 10\log(P)$  dB below the transmitter power P(Watts)  
 $= P(W) - [43 + 10\log(P)] \text{ (dB)}$   
 $= [30 + 10\log(P)] \text{ (dBm)} - [43 + 10\log(P)] \text{ (dB)}$   
 $= -13\text{dBm}.$

### 3.5.4 Test Setup

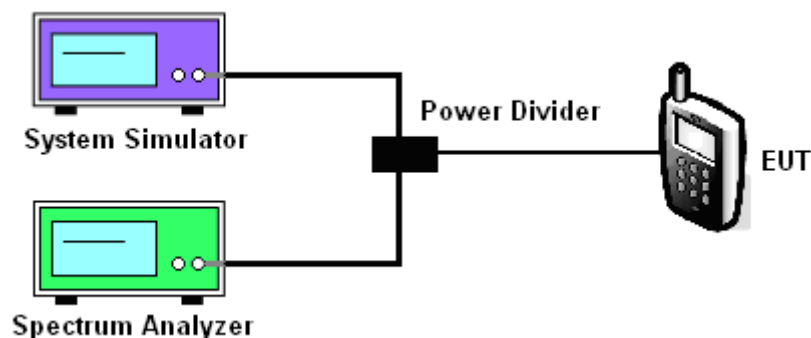



### 3.5.5 Test Result (Plots) of Conducted Band Edge

Band :	GSM850	Test Mode :	GPRS class 8 Link (GMSK)
--------	--------	-------------	--------------------------

#### Lower Band Edge Plot on Channel 128 (824.2 MHz)

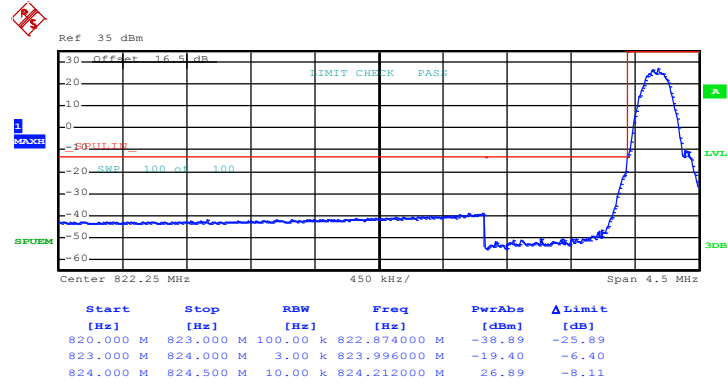

Date: 17.OCT.2014 19:36:29

#### Higher Band Edge Plot on Channel 251 (848.8 MHz)

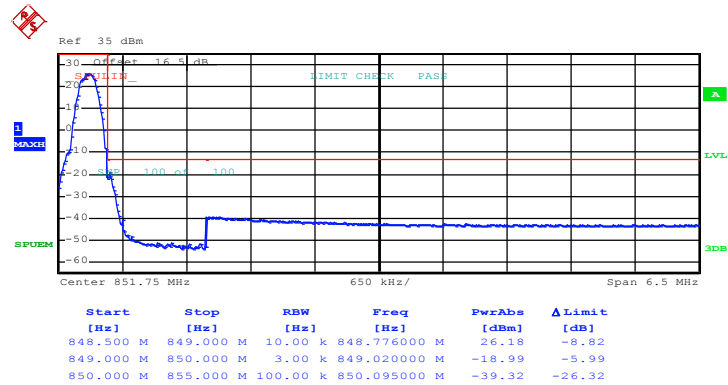

Date: 17.OCT.2014 19:32:47



Band :	GSM850	Test Mode :	EDGE class 8 Link (8PSK)
--------	--------	-------------	--------------------------

Lower Band Edge Plot on Channel 128 (824.2 MHz)

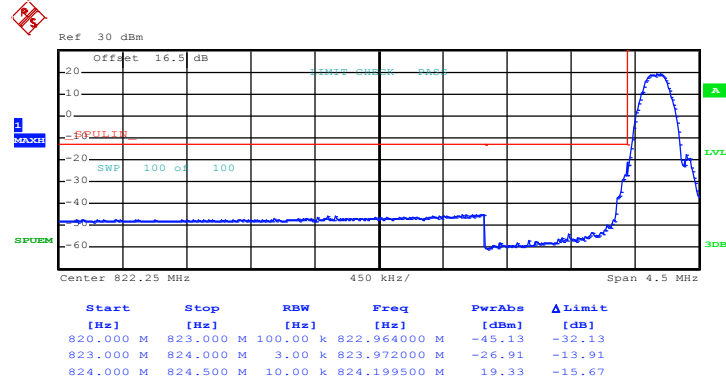

Date: 17.OCT.2014 20:08:22

Higher Band Edge Plot on Channel 251 (848.8 MHz)

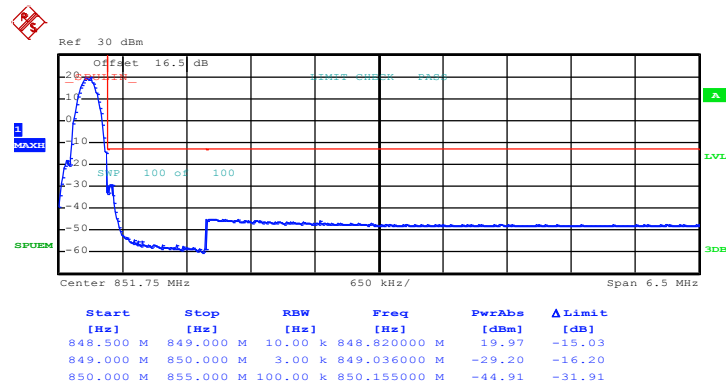

Date: 17.OCT.2014 20:04:27



Band :	GSM1900	Test Mode :	GSM Link (GMSK)
--------	---------	-------------	-----------------

Lower Band Edge Plot on Channel 512 (1850.2 MHz)

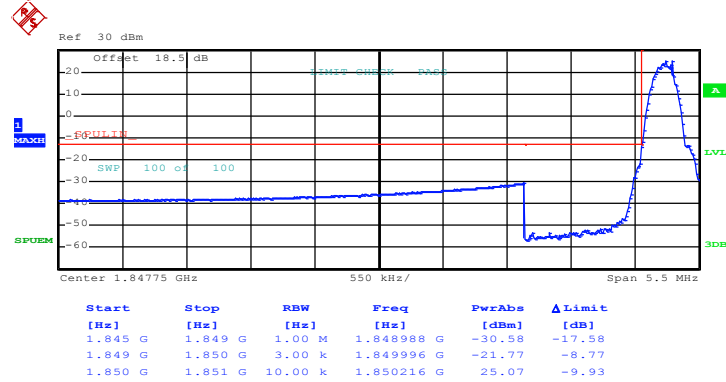

Date: 17.OCT.2014 21:05:59

Higher Band Edge Plot on Channel 810 (1909.8 MHz)

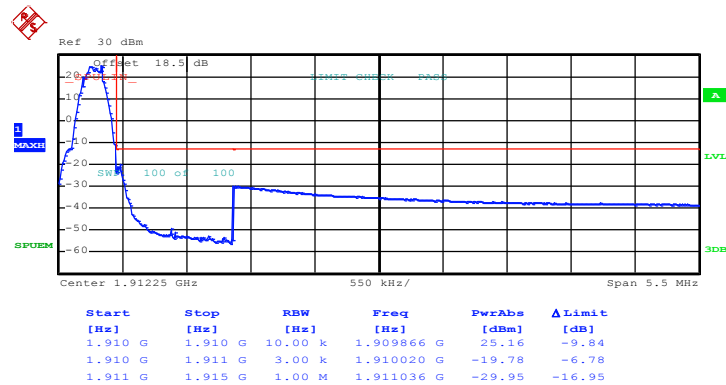

Date: 17.OCT.2014 21:02:18



Band :	GSM1900	Test Mode :	EDGE class 8 Link (8PSK)
--------	---------	-------------	--------------------------

Lower Band Edge Plot on Channel 512 (1850.2 MHz)

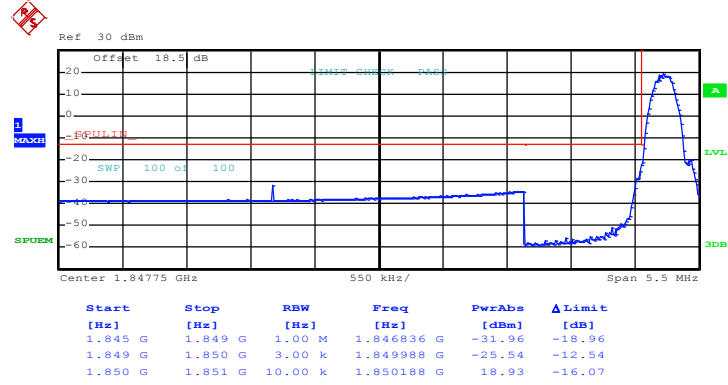

Date: 17.OCT.2014 21:56:25

Higher Band Edge Plot on Channel 810 (1909.8 MHz)

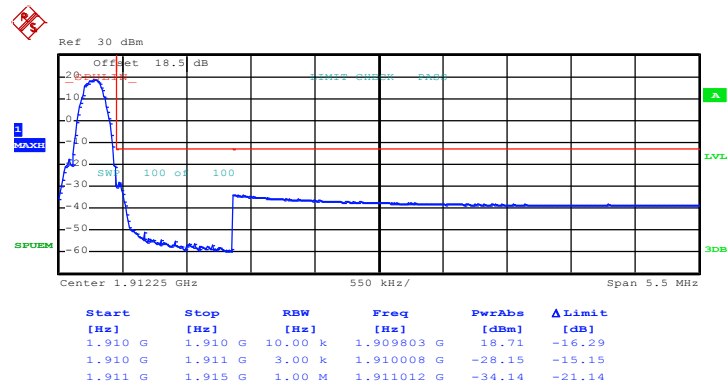

Date: 17.OCT.2014 21:49:58



Band :	WCDMA Band V	Test Mode :	RMC 12.2Kbps Link (QPSK)
--------	--------------	-------------	--------------------------

Lower Band Edge Plot on Channel 4132 (826.4 MHz)

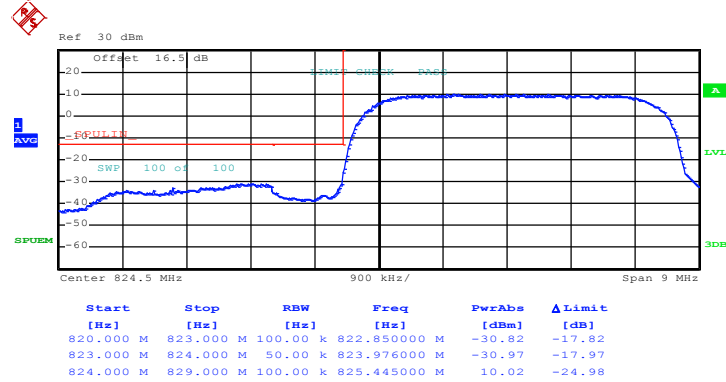

Date: 17.OCT.2014 20:40:28

Higher Band Edge Plot on Channel 4233 (846.6 MHz)

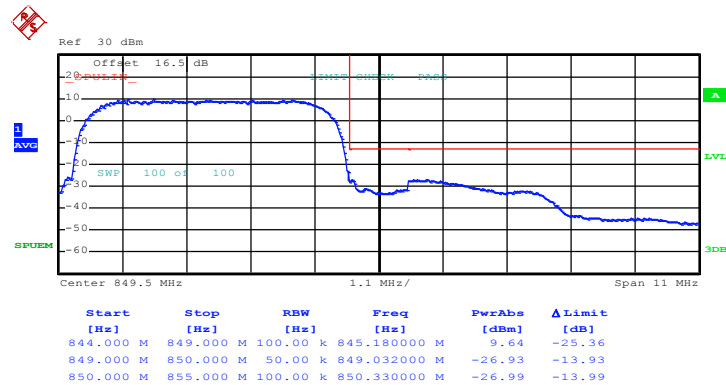

Date: 17.OCT.2014 20:36:37



Band :	WCDMA Band II	Test Mode :	RMC 12.2Kbps Link (QPSK)
--------	---------------	-------------	--------------------------

Lower Band Edge Plot on Channel 9262 (1852.4 MHz)

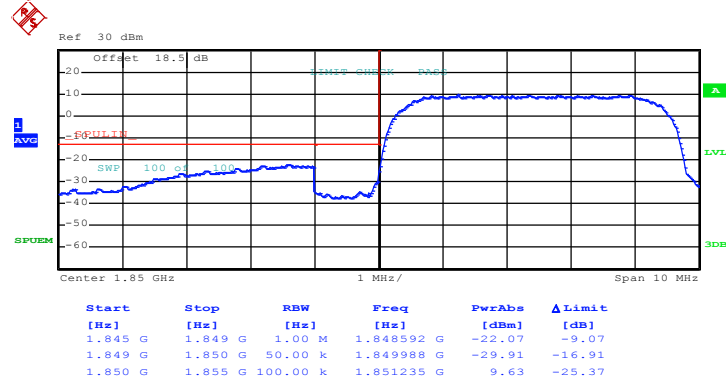

Date: 17.OCT.2014 22:24:24

Higher Band Edge Plot on Channel 9538 (1907.6 MHz)

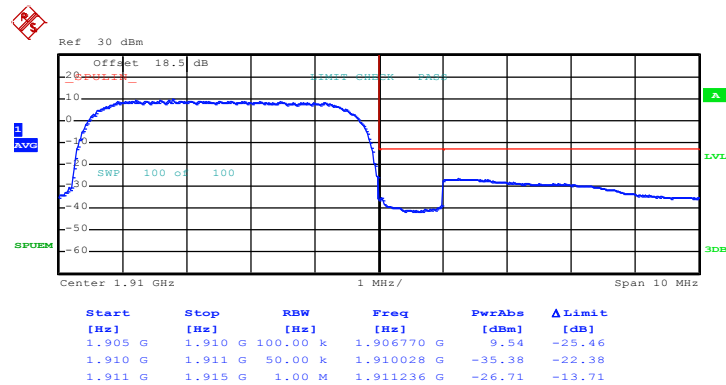

Date: 17.OCT.2014 22:20:47

## 3.6 Conducted Spurious Emission Measurement

### 3.6.1 Description of Conducted Spurious Emission Measurement

The power of any emission outside of the authorized operating frequency ranges must be lower than the transmitter power (P) by a factor of at least  $43 + 10 \log (P)$  dB.

It is measured by means of a calibrated spectrum analyzer and scanned from 30 MHz up to a frequency including its 10<sup>th</sup> harmonic.

### 3.6.2 Measuring Instruments

The measuring equipment is listed in the section 4 of this test report.

### 3.6.3 Test Procedures

1. The testing follows FCC KDB 971168 v02r02 Section 6.0.
2. The EUT was connected to the spectrum analyzer and system simulator via a power divider.
3. The RF output of EUT was connected to the spectrum analyzer by an RF cable and attenuator. The path loss was compensated to the results for each measurement.
4. The middle channel for the highest RF power within the transmitting frequency was measured.
5. The conducted spurious emission for the whole frequency range was taken.
6. The RF fundamental frequency should be excluded against the limit line in the operating frequency band.
7. The limit line is derived from  $43 + 10\log(P)$  dB below the transmitter power P(Watts)  
 $= P(W) - [43 + 10\log(P)]$  (dB)  
 $= [30 + 10\log(P)]$  (dBm) -  $[43 + 10\log(P)]$  (dB)  
 $= -13\text{dBm}$ .

### 3.6.4 Test Setup

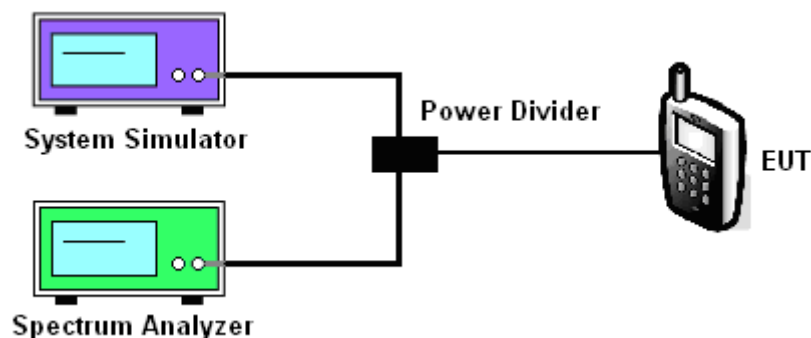

### 3.6.5 Test Result (Plots) of Conducted Spurious Emission

Band :	GSM850	Channel :	CH128
Test Mode :	GPRS class 8 Link (GMSK)	Frequency :	824.2 MHz

Conducted Spurious Emission Plot between 30MHz ~ 1GHz

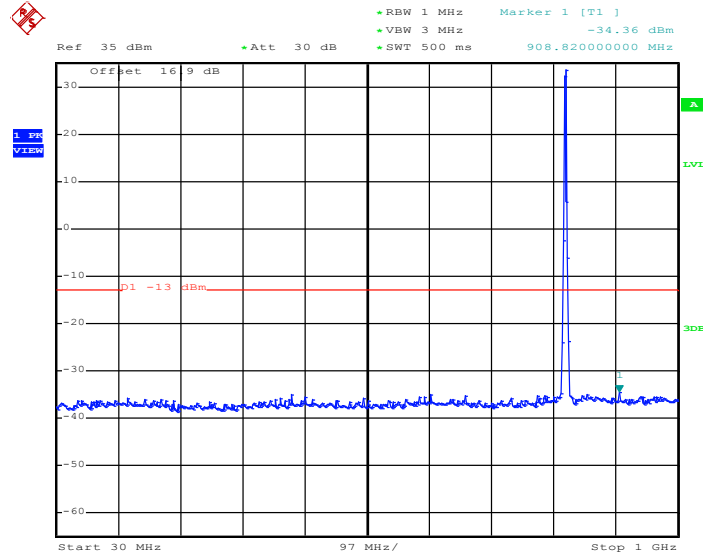

Date: 17.OCT.2014 19:22:57

Conducted Spurious Emission Plot between 1GHz ~ 3GHz

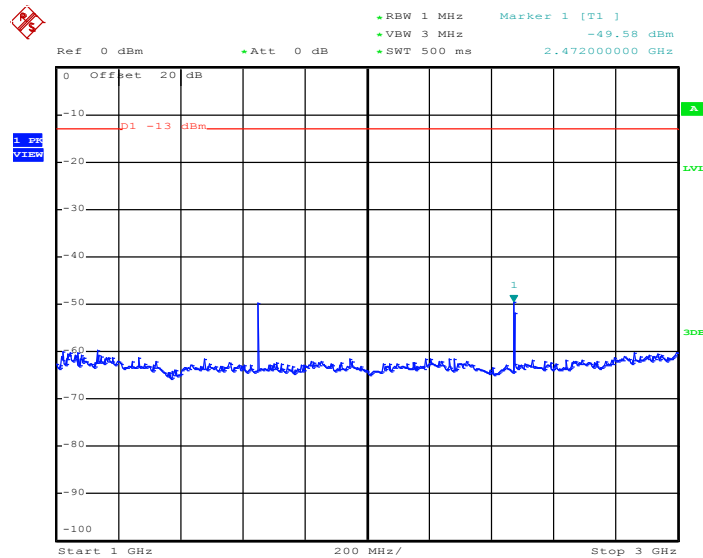

Date: 17.OCT.2014 19:23:13



### Conducted Spurious Emission Plot between 3GHz ~ 7GHz

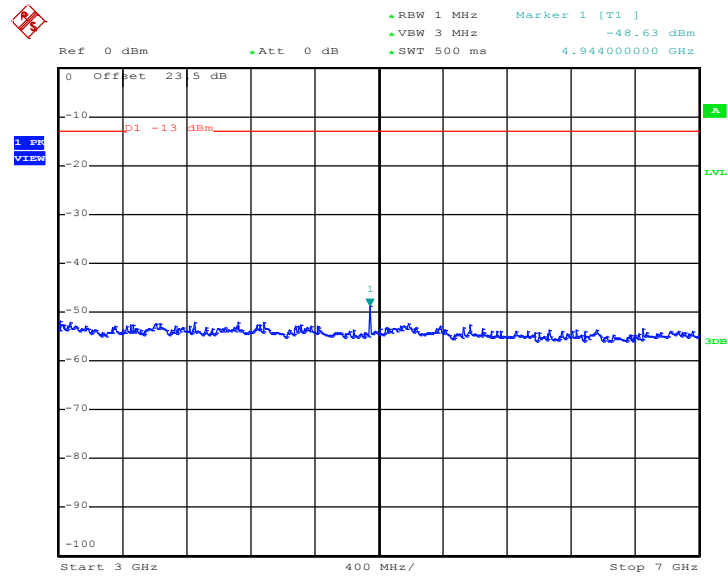

Date: 17.OCT.2014 19:23:22

### Conducted Spurious Emission Plot between 7GHz ~ 9GHz

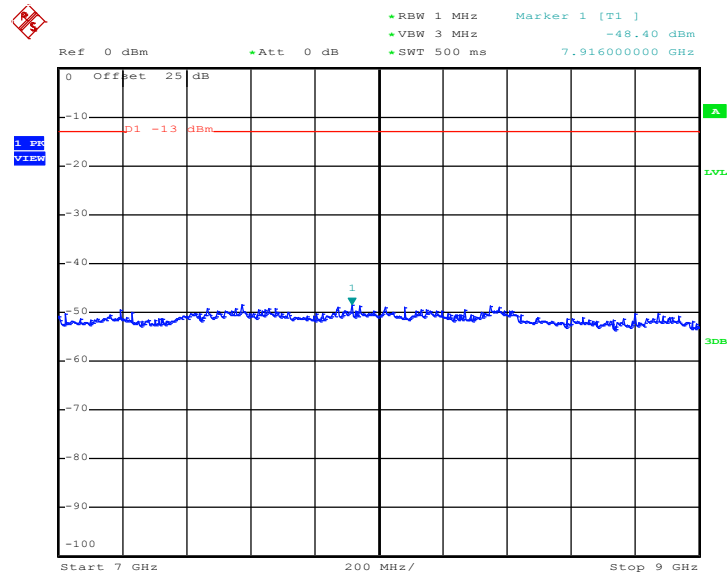

Date: 17.OCT.2014 19:23:30



<b>Band :</b>	GSM850	<b>Channel :</b>	CH189
<b>Test Mode :</b>	GPRS class 8 Link (GMSK)	<b>Frequency :</b>	836.4 MHz

Conducted Spurious Emission Plot between 30MHz ~ 1GHz

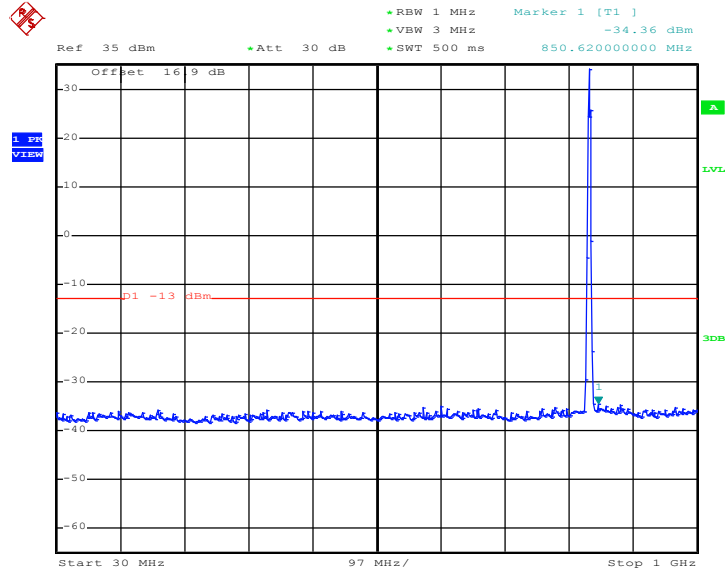

Date: 17.OCT.2014 19:24:24

Conducted Spurious Emission Plot between 1GHz ~ 3GHz

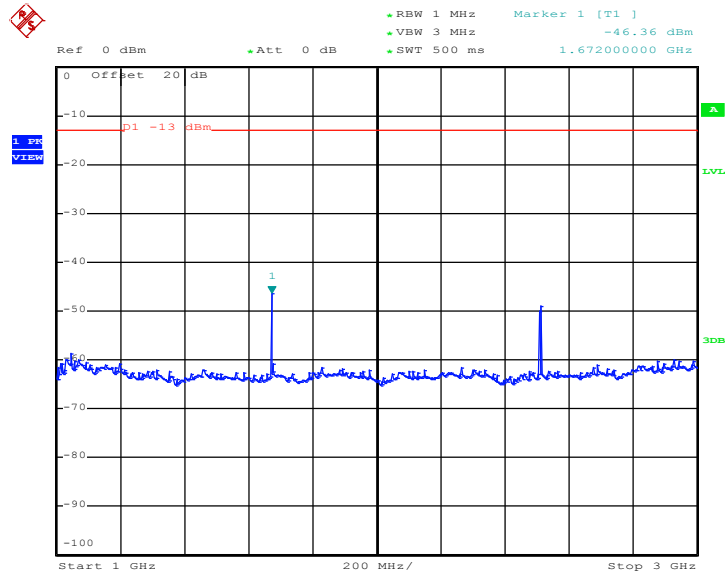

Date: 17.OCT.2014 19:24:45



### Conducted Spurious Emission Plot between 3GHz ~ 7GHz

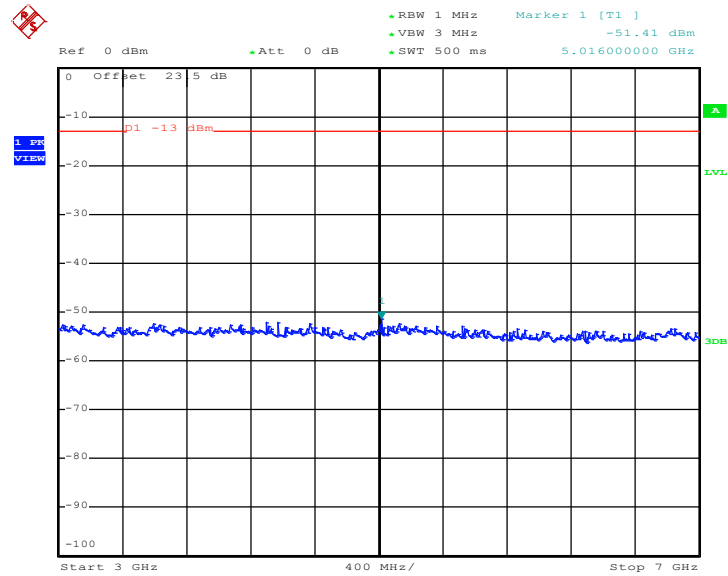

Date: 17.OCT.2014 19:24:53

### Conducted Spurious Emission Plot between 7GHz ~ 9GHz

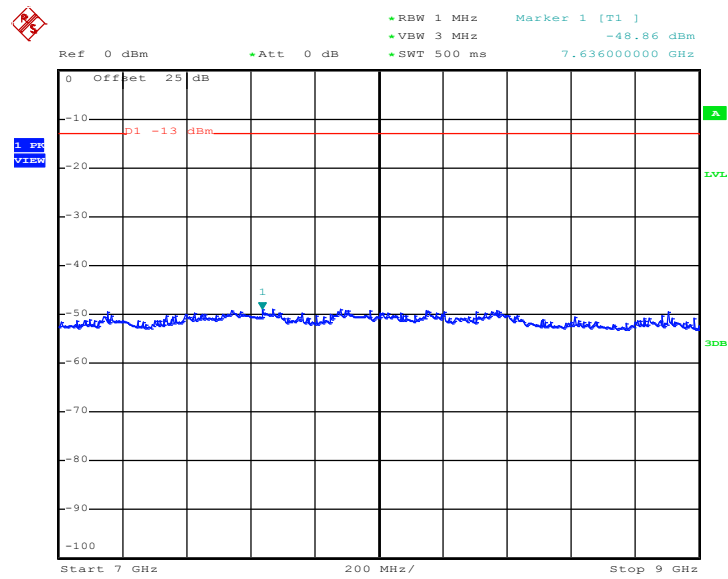

Date: 17.OCT.2014 19:25:02



<b>Band :</b>	GSM850	<b>Channel :</b>	CH251
<b>Test Mode :</b>	GPRS class 8 Link (GMSK)	<b>Frequency :</b>	848.8 MHz

Conducted Spurious Emission Plot between 30MHz ~ 1GHz

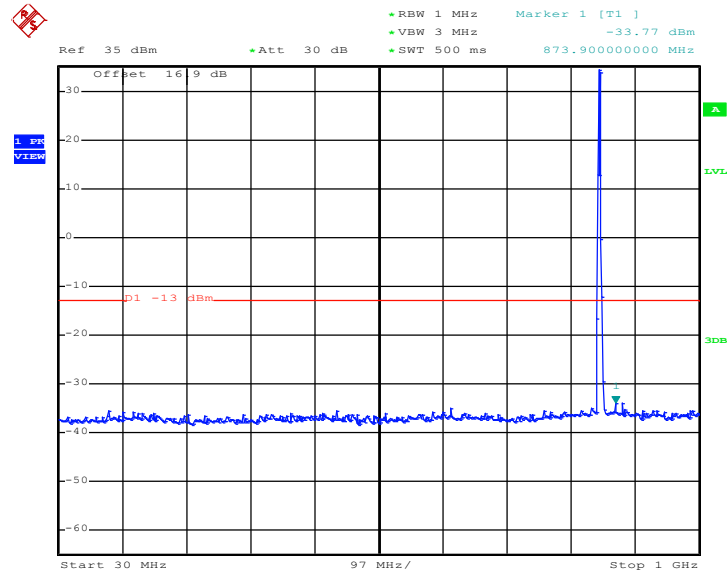

Date: 17.OCT.2014 19:19:56

Conducted Spurious Emission Plot between 1GHz ~ 3GHz

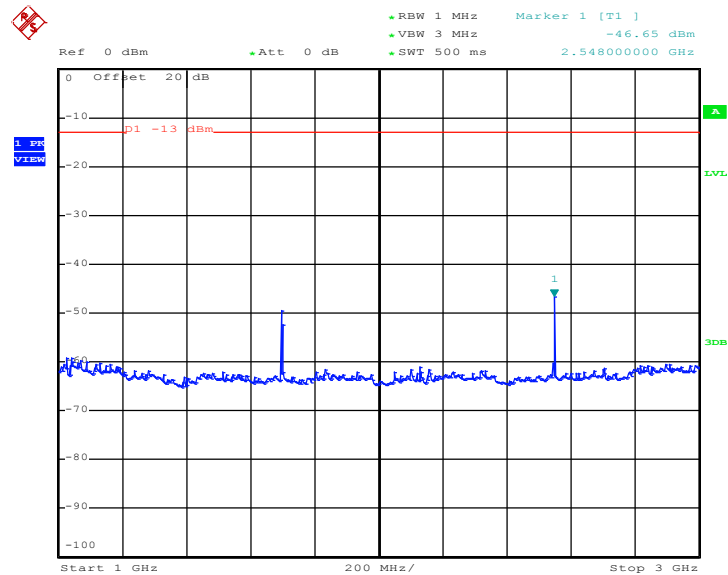

Date: 17.OCT.2014 19:20:10



### Conducted Spurious Emission Plot between 3GHz ~ 7GHz

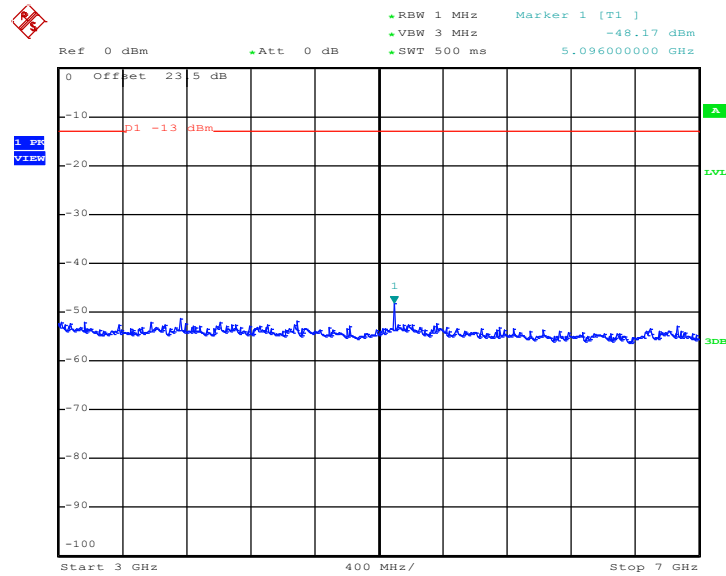

Date: 17.OCT.2014 19:20:19

### Conducted Spurious Emission Plot between 7GHz ~ 9GHz

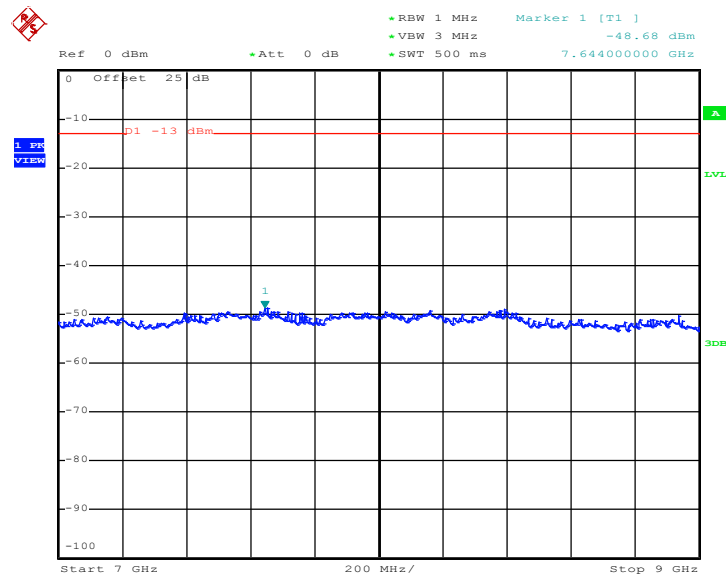

Date: 17.OCT.2014 19:20:27



Band :	GSM850	Channel :	CH128
Test Mode :	EDGE class 8 Link (8PSK)	Frequency :	824.2 MHz

Conducted Spurious Emission Plot between 30MHz ~ 1GHz

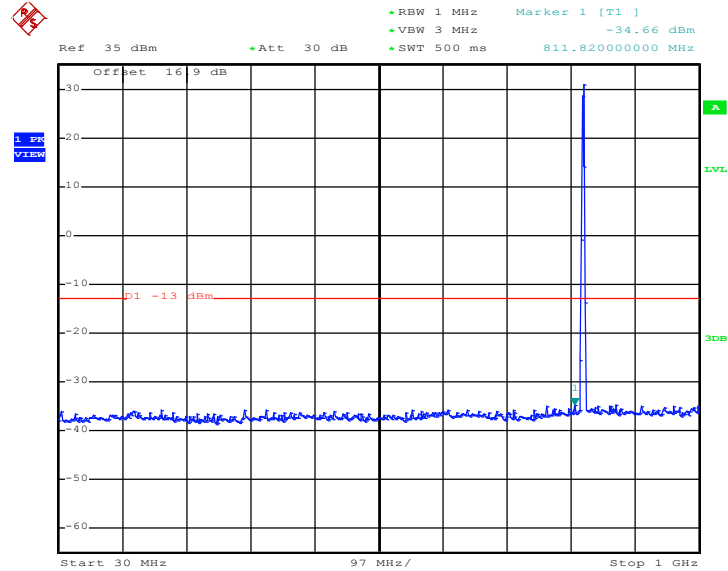

Date: 17.OCT.2014 19:53:31

Conducted Spurious Emission Plot between 1GHz ~ 3GHz

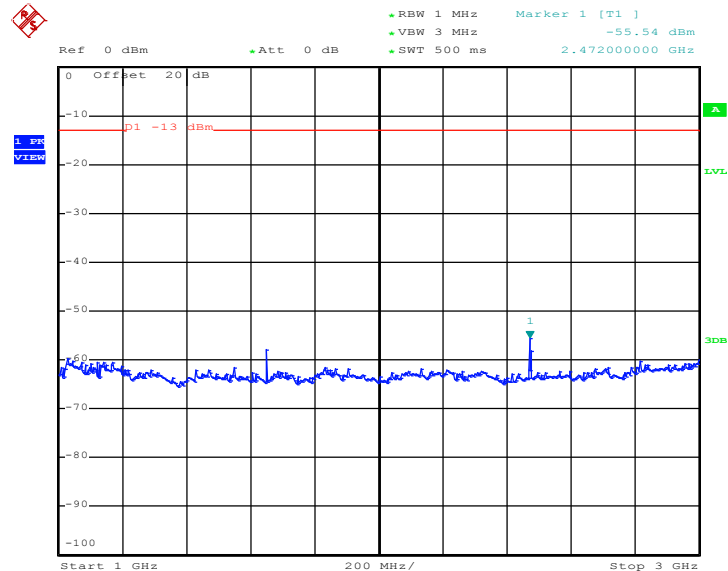

Date: 17.OCT.2014 19:53:45



### Conducted Spurious Emission Plot between 3GHz ~ 7GHz

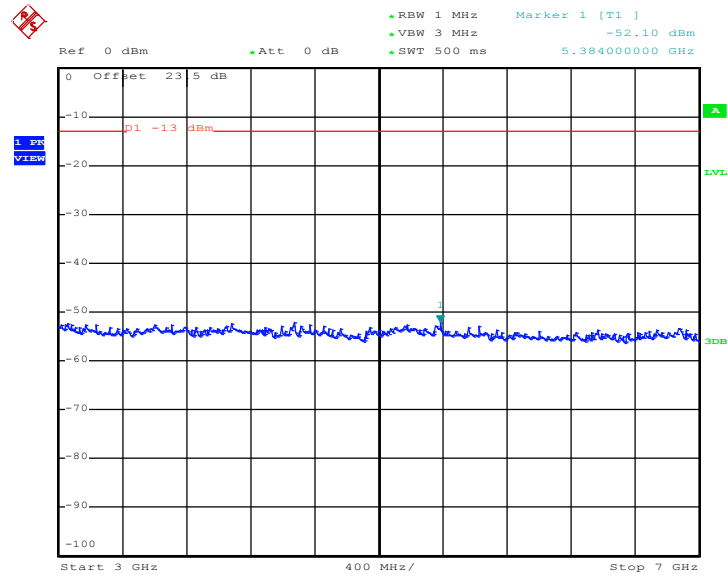

Date: 17.OCT.2014 19:53:53

### Conducted Spurious Emission Plot between 7GHz ~ 9GHz

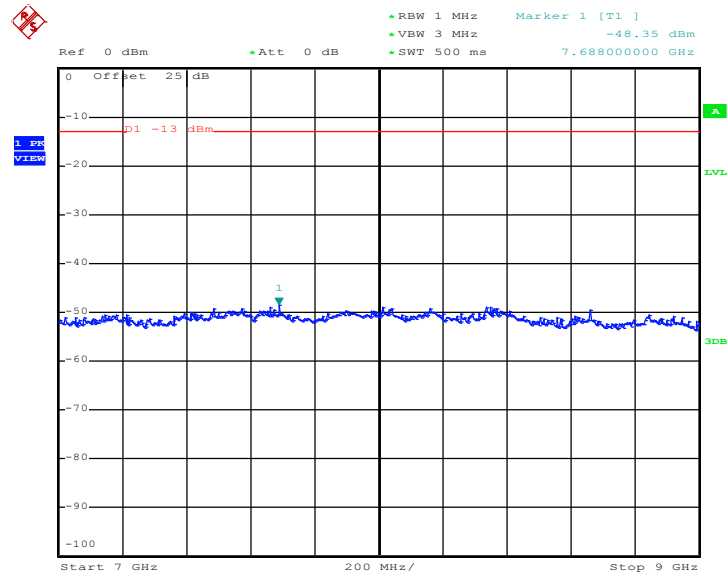

Date: 17.OCT.2014 19:54:01



<b>Band :</b>	GSM850	<b>Channel :</b>	CH189
<b>Test Mode :</b>	EDGE class 8 Link (8PSK)	<b>Frequency :</b>	836.4 MHz

Conducted Spurious Emission Plot between 30MHz ~ 1GHz

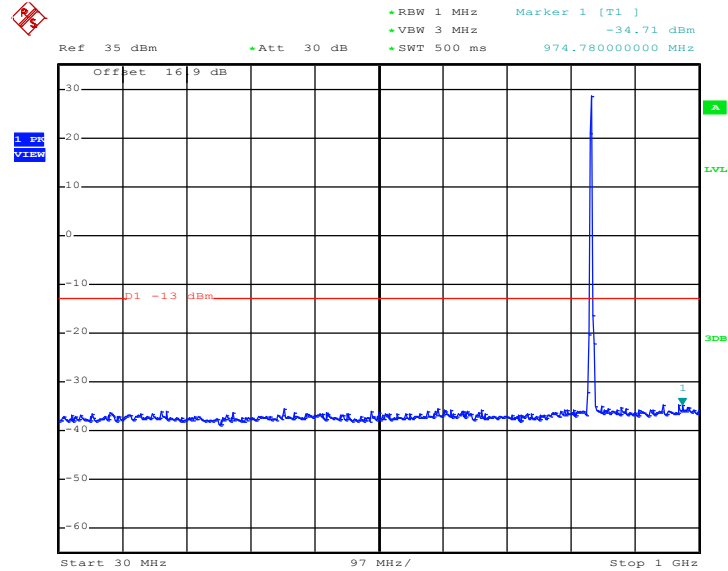

Date: 17.OCT.2014 19:57:18

Conducted Spurious Emission Plot between 1GHz ~ 3GHz

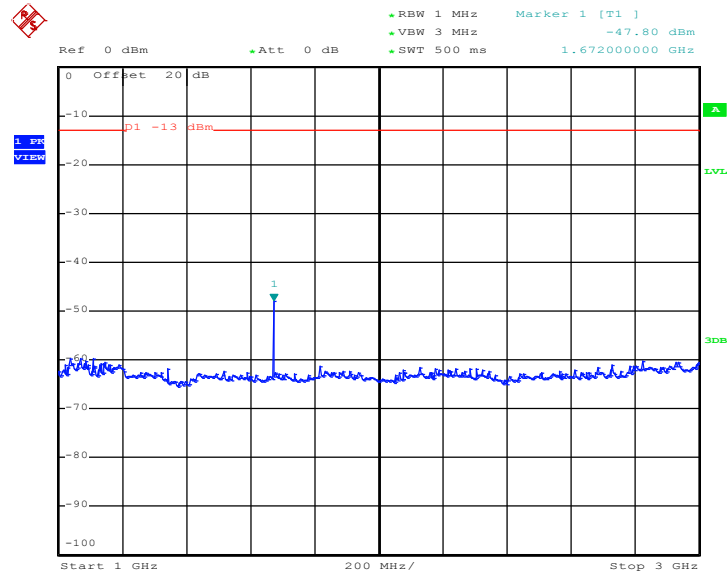

Date: 17.OCT.2014 19:57:33



### Conducted Spurious Emission Plot between 3GHz ~ 7GHz

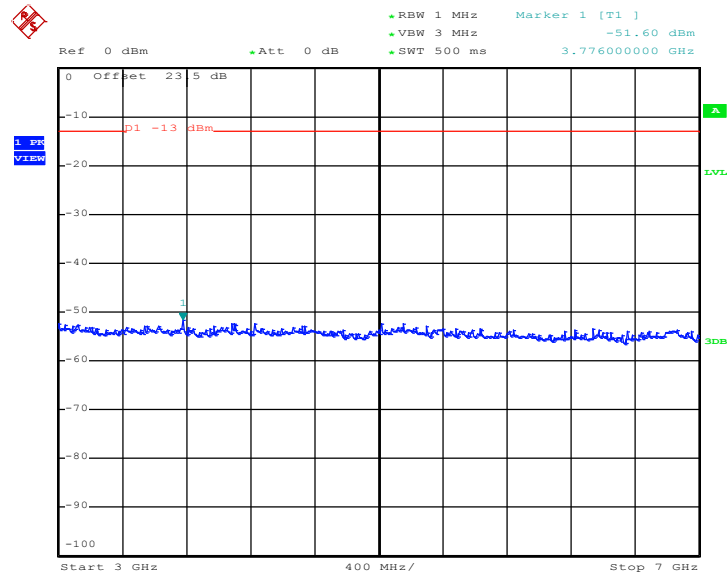

Date: 17.OCT.2014 19:57:41

### Conducted Spurious Emission Plot between 7GHz ~ 9GHz

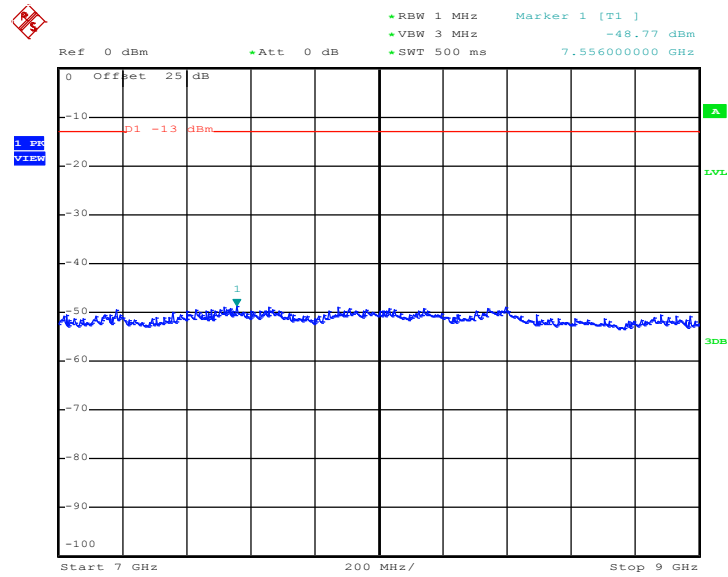

Date: 17.OCT.2014 19:57:49



<b>Band :</b>	GSM850	<b>Channel :</b>	CH251
<b>Test Mode :</b>	EDGE class 8 Link (8PSK)	<b>Frequency :</b>	848.8 MHz

Conducted Spurious Emission Plot between 30MHz ~ 1GHz

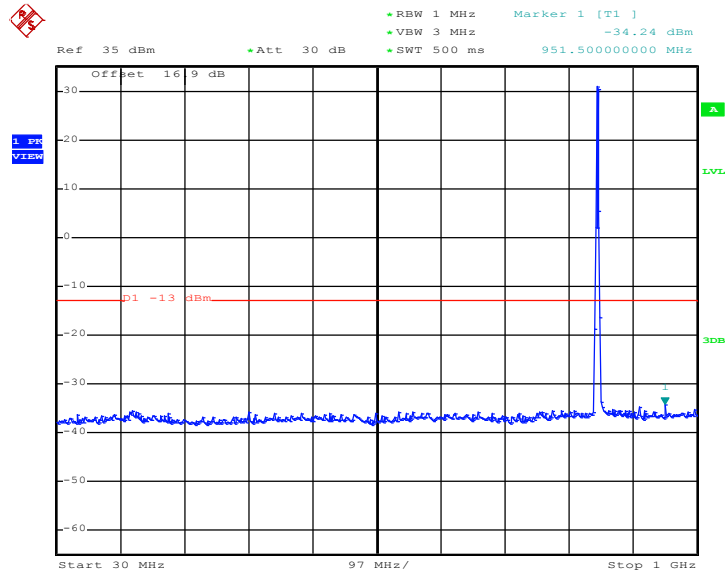

Date: 17.OCT.2014 19:52:23

Conducted Spurious Emission Plot between 1GHz ~ 3GHz

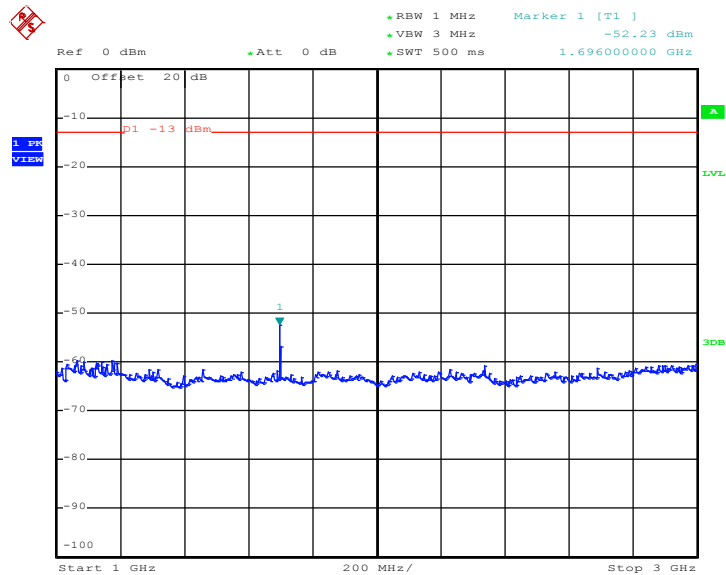

Date: 17.OCT.2014 19:52:35



### Conducted Spurious Emission Plot between 3GHz ~ 7GHz

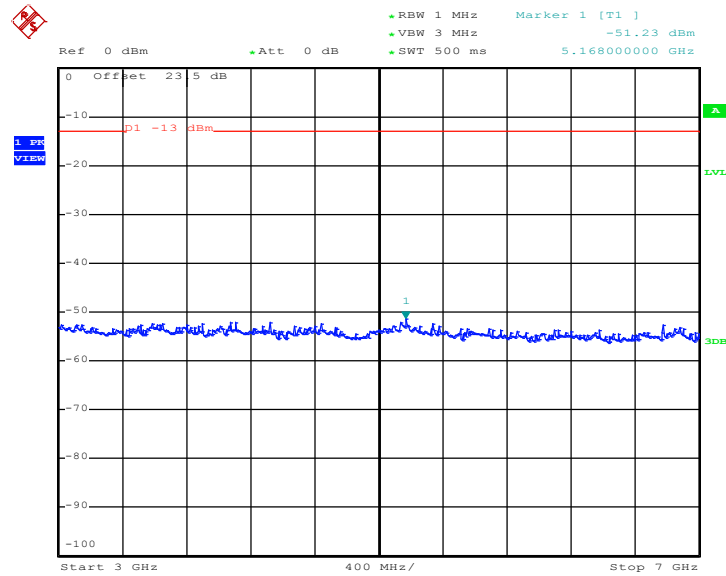

Date: 17.OCT.2014 19:52:43

### Conducted Spurious Emission Plot between 7GHz ~ 9GHz

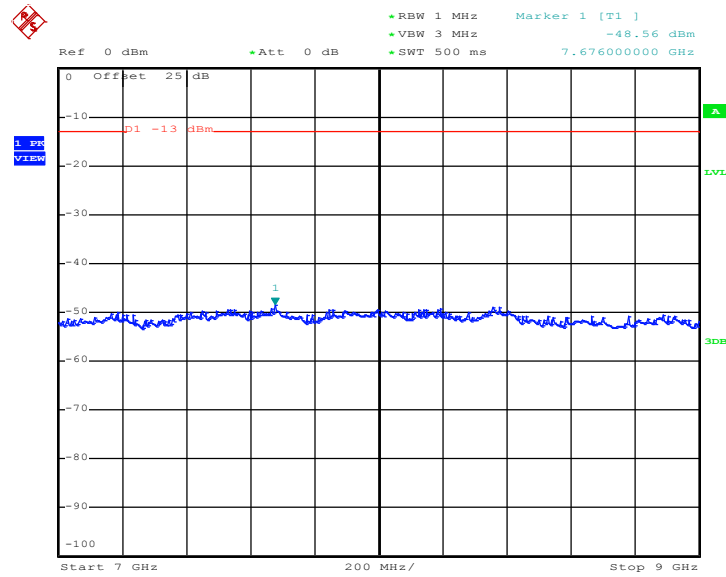

Date: 17.OCT.2014 19:52:51



Band :	GSM1900	Channel :	CH512
Test Mode :	GSM Link (GMSK)	Frequency :	1850.2 MHz

Conducted Spurious Emission Plot between 30MHz ~ 1GHz

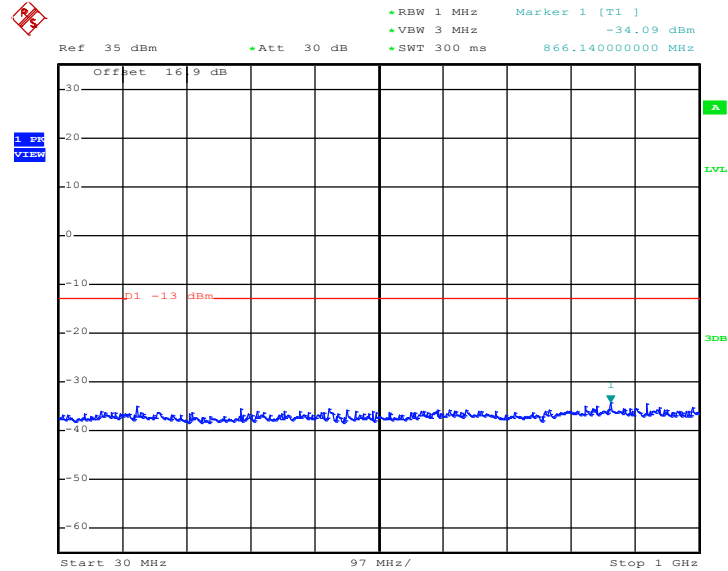

Date: 17.OCT.2014 20:54:52

Conducted Spurious Emission Plot between 1GHz ~ 3GHz

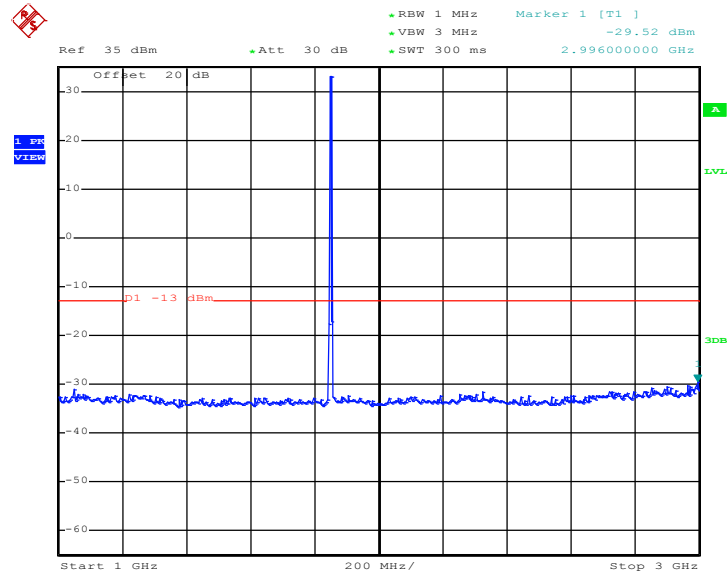

Date: 17.OCT.2014 20:55:00



### Conducted Spurious Emission Plot between 3GHz ~ 7GHz

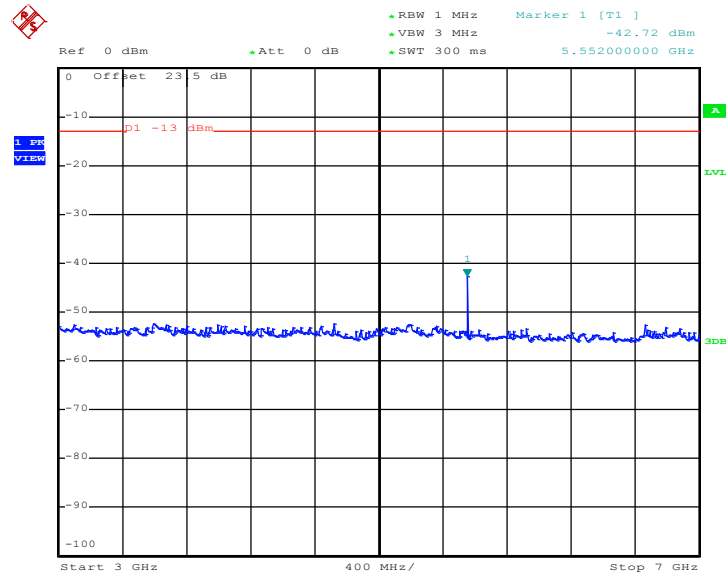

Date: 17.OCT.2014 20:55:13

### Conducted Spurious Emission Plot between 7GHz ~ 13.6GHz

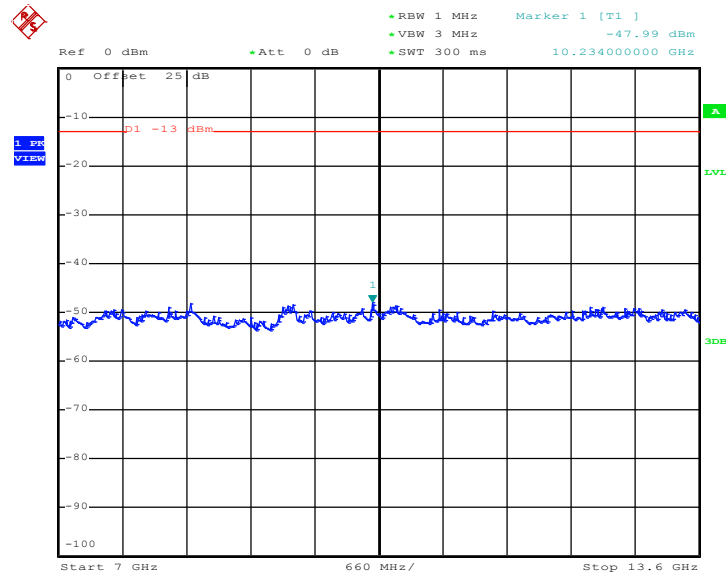

Date: 17.OCT.2014 20:55:22



Conducted Spurious Emission Plot between 13.6GHz ~ 19.1GHz

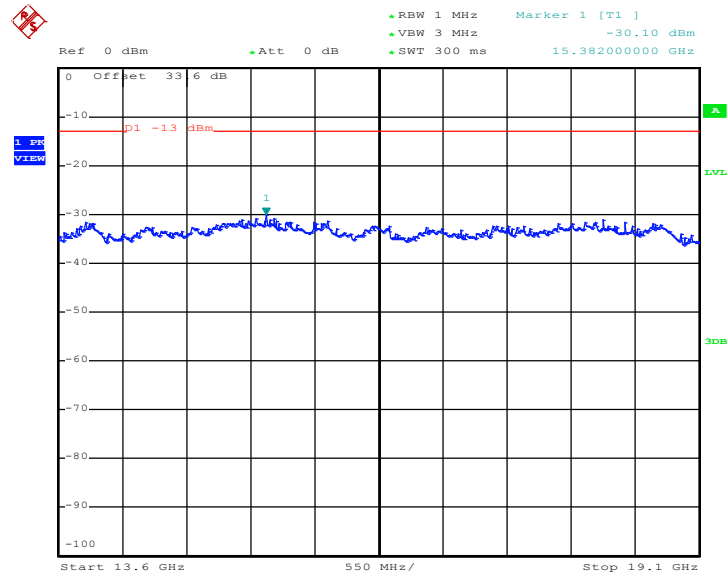

Date: 17.OCT.2014 20:55:30



Band :	GSM1900	Channel :	CH661
Test Mode :	GSM Link (GMSK)	Frequency :	1880.0 MHz

Conducted Spurious Emission Plot between 30MHz ~ 1GHz

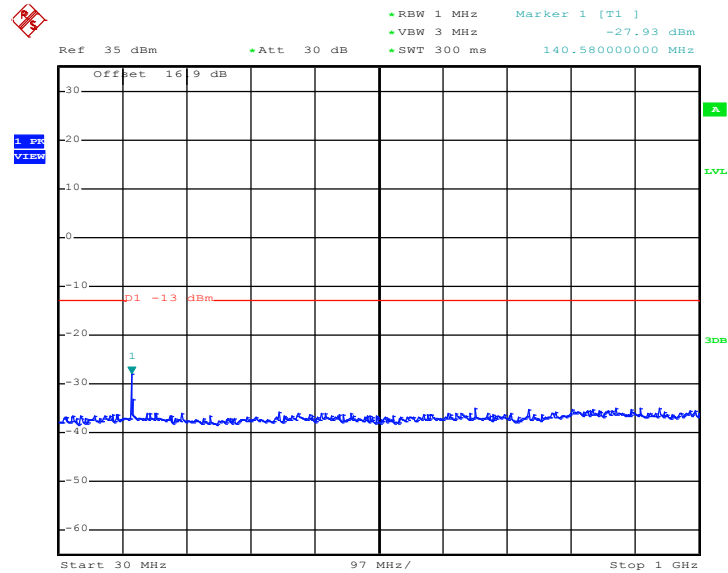

Date: 17.OCT.2014 20:57:14

Conducted Spurious Emission Plot between 1GHz ~ 3GHz

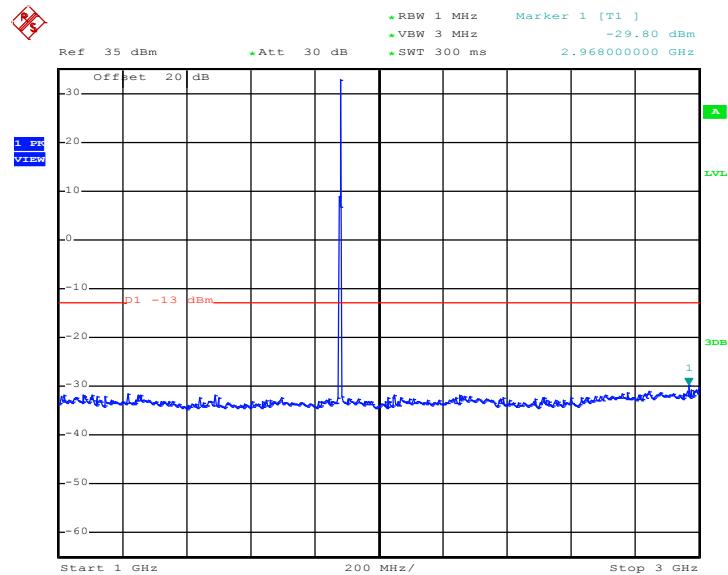

Date: 17.OCT.2014 20:57:22



### Conducted Spurious Emission Plot between 3GHz ~ 7GHz

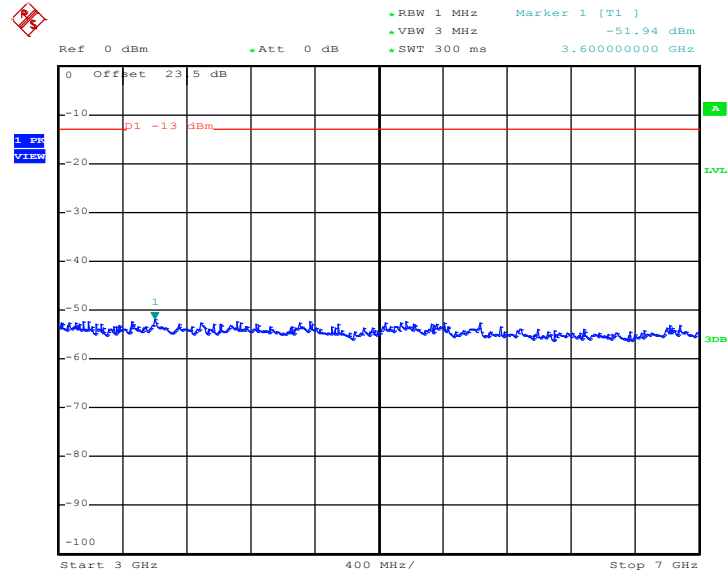

Date: 17.OCT.2014 20:57:35

### Conducted Spurious Emission Plot between 7GHz ~ 13.6GHz

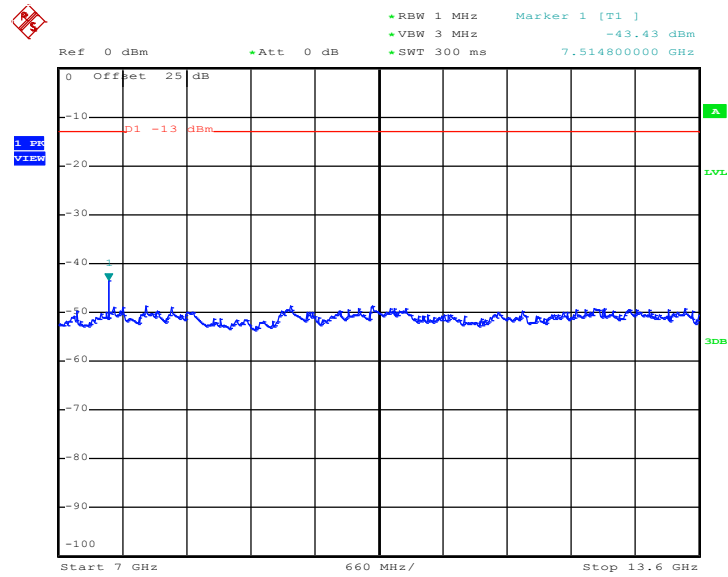

Date: 17.OCT.2014 20:57:44



Conducted Spurious Emission Plot between 13.6GHz ~ 19.1GHz

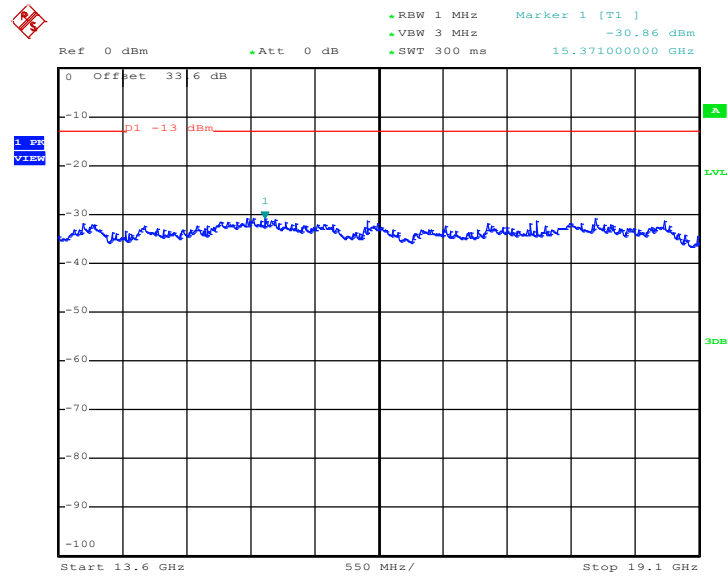

Date: 17.OCT.2014 20:57:52



<b>Band :</b>	GSM1900	<b>Channel :</b>	CH810
<b>Test Mode :</b>	GSM Link (GMSK)	<b>Frequency :</b>	1909.8 MHz

Conducted Spurious Emission Plot between 30MHz ~ 1GHz

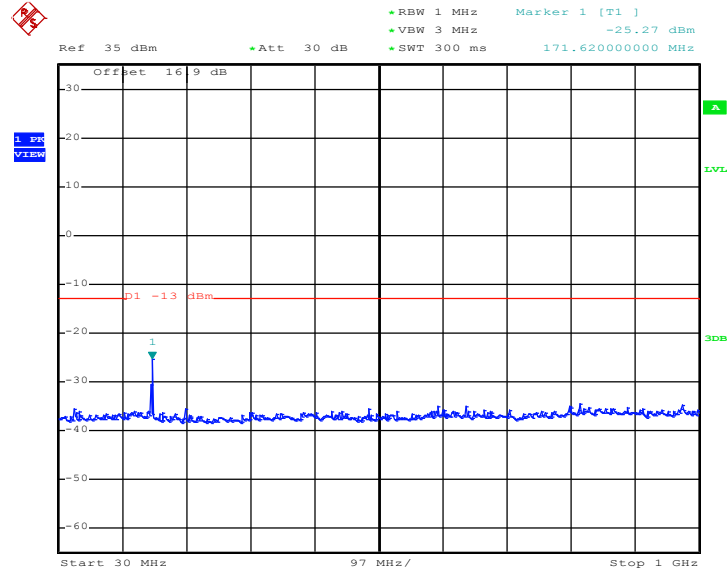

Date: 17.OCT.2014 20:53:35

Conducted Spurious Emission Plot between 1GHz ~ 3GHz

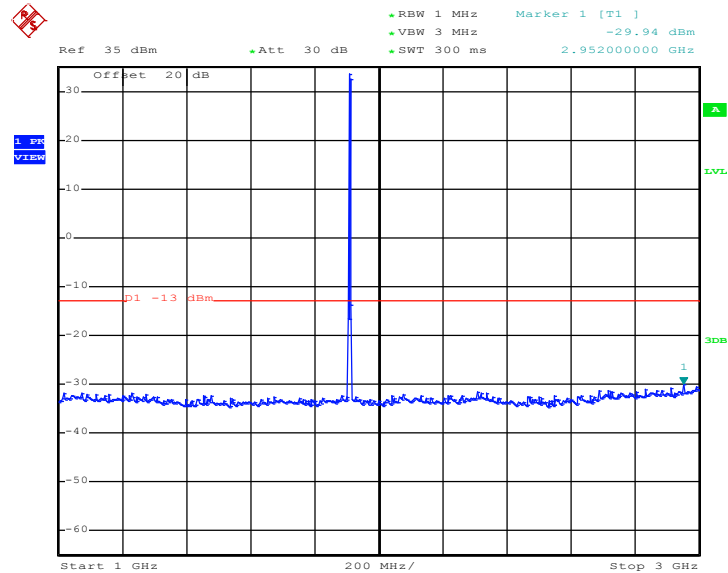

Date: 17.OCT.2014 20:53:44



### Conducted Spurious Emission Plot between 3GHz ~ 7GHz

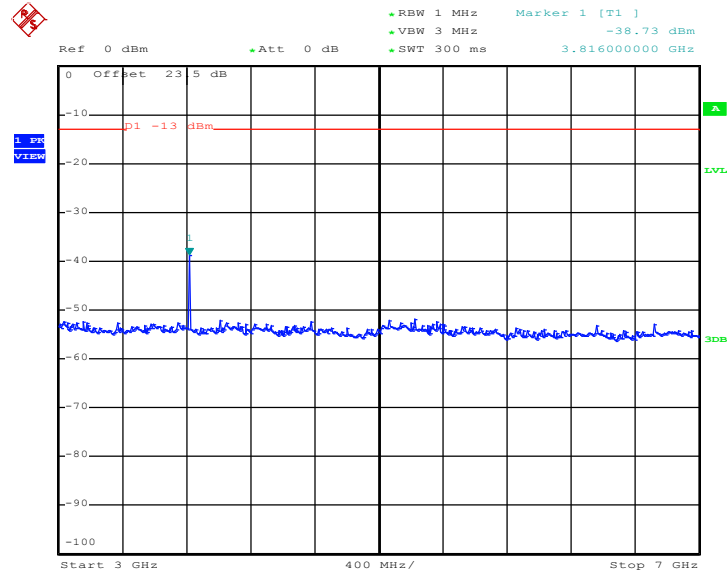

Date: 17.OCT.2014 20:53:56

### Conducted Spurious Emission Plot between 7GHz ~ 13.6GHz

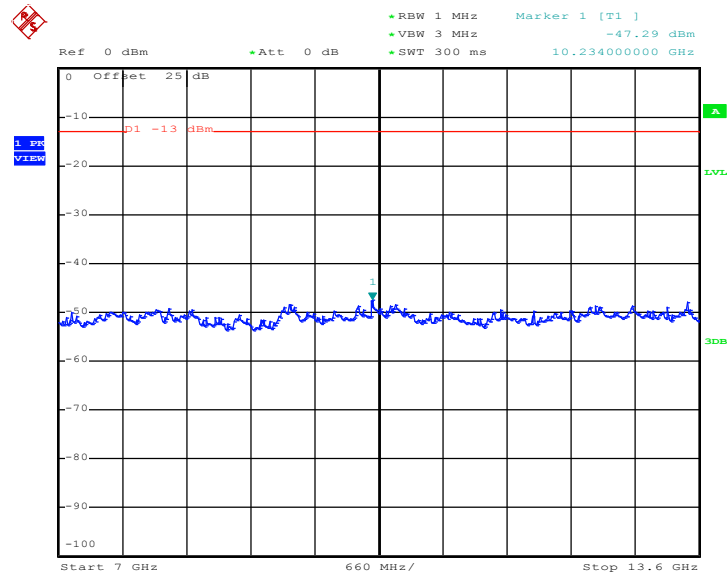

Date: 17.OCT.2014 20:54:04



Conducted Spurious Emission Plot between 13.6GHz ~ 19.1GHz

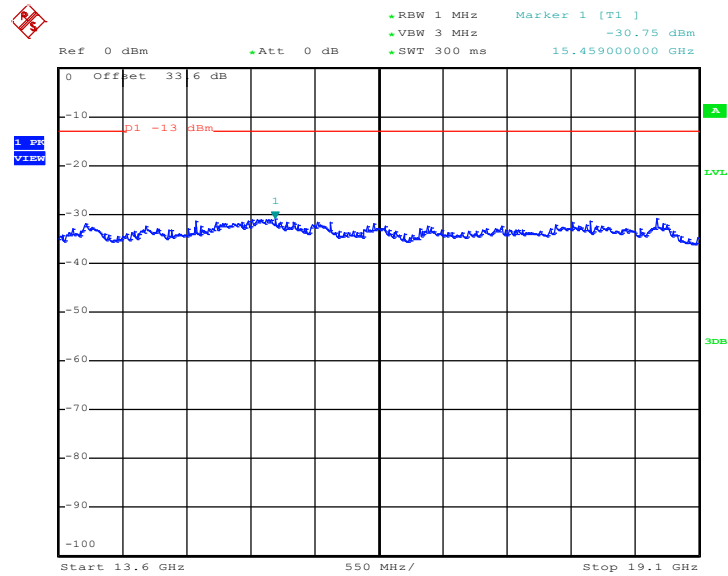

Date: 17.OCT.2014 20:54:13



<b>Band :</b>	GSM1900	<b>Channel :</b>	CH512
<b>Test Mode :</b>	EDGE class 8 Link (8PSK)	<b>Frequency :</b>	1850.2 MHz

Conducted Spurious Emission Plot between 30MHz ~ 1GHz

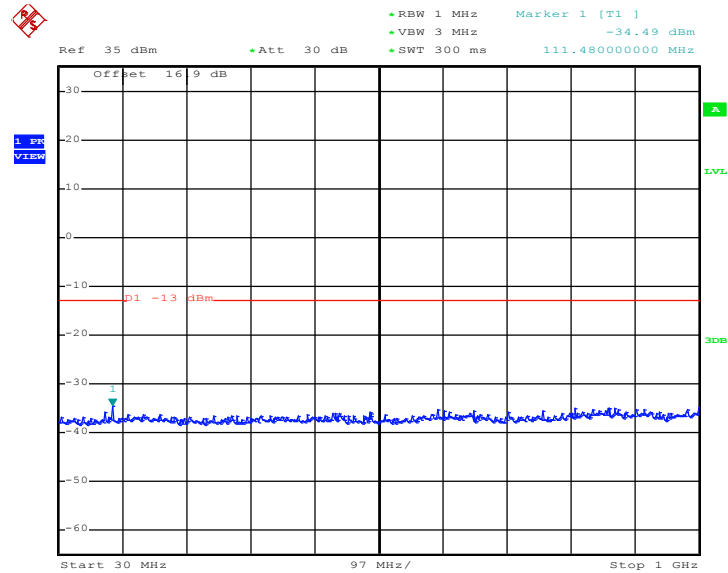

Date: 17.OCT.2014 21:38:11

Conducted Spurious Emission Plot between 1GHz ~ 3GHz

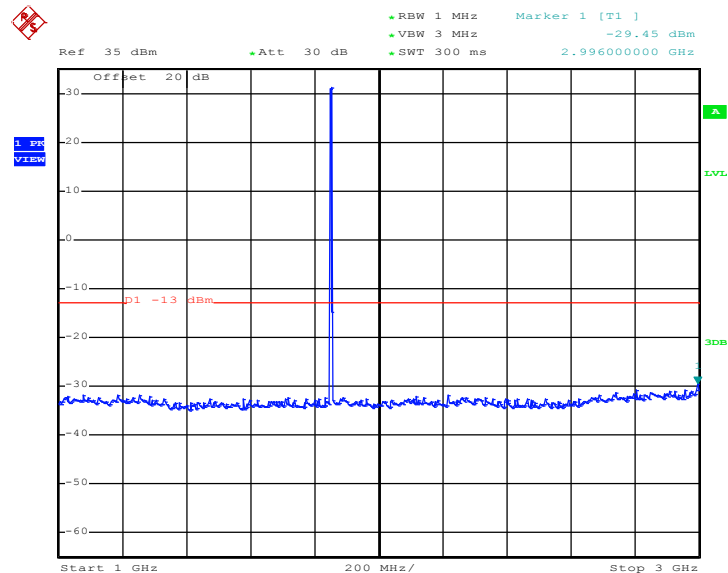

Date: 17.OCT.2014 21:38:19



### Conducted Spurious Emission Plot between 3GHz ~ 7GHz

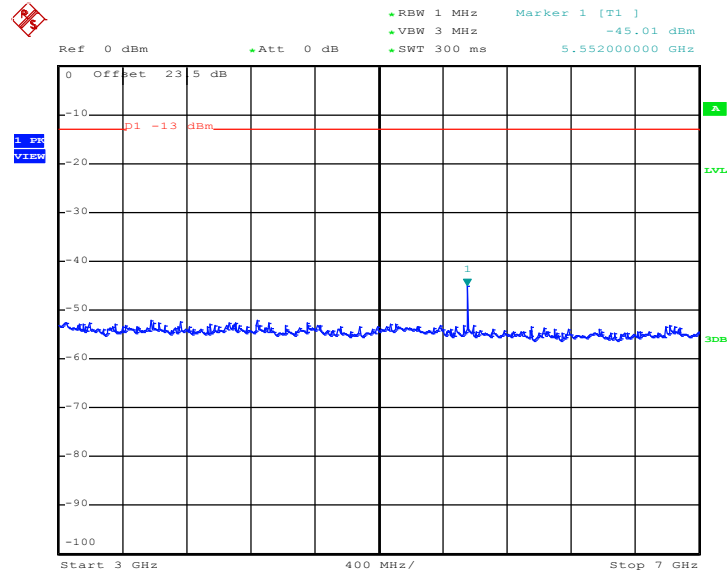

Date: 17.OCT.2014 21:39:00

### Conducted Spurious Emission Plot between 7GHz ~ 13.6GHz

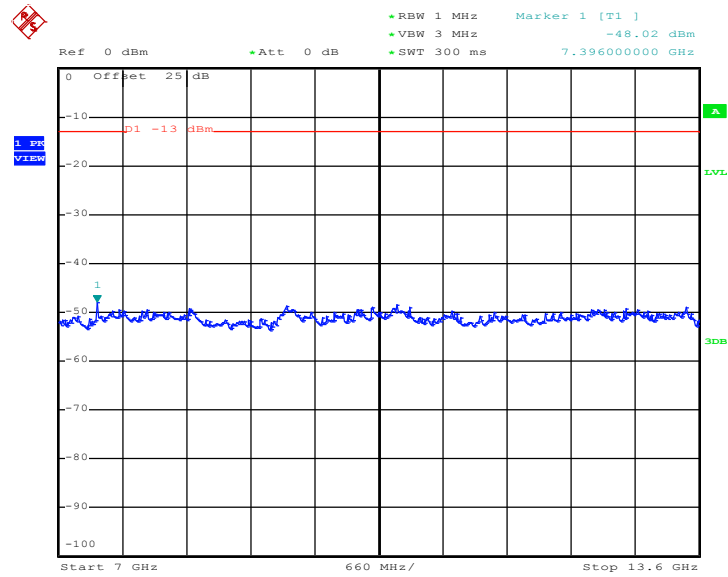

Date: 17.OCT.2014 21:39:08



Conducted Spurious Emission Plot between 13.6GHz ~ 19.1GHz

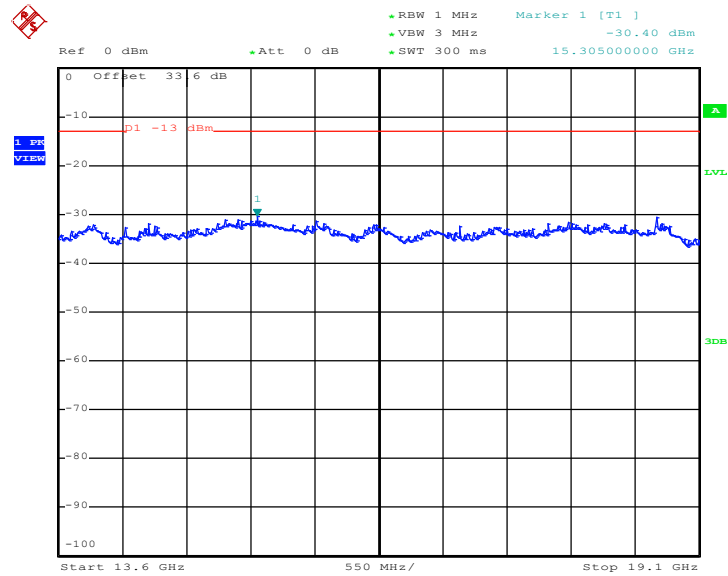

Date: 17.OCT.2014 21:39:17



<b>Band :</b>	GSM1900	<b>Channel :</b>	CH661
<b>Test Mode :</b>	EDGE class 8 Link (8PSK)	<b>Frequency :</b>	1880.0 MHz

Conducted Spurious Emission Plot between 30MHz ~ 1GHz

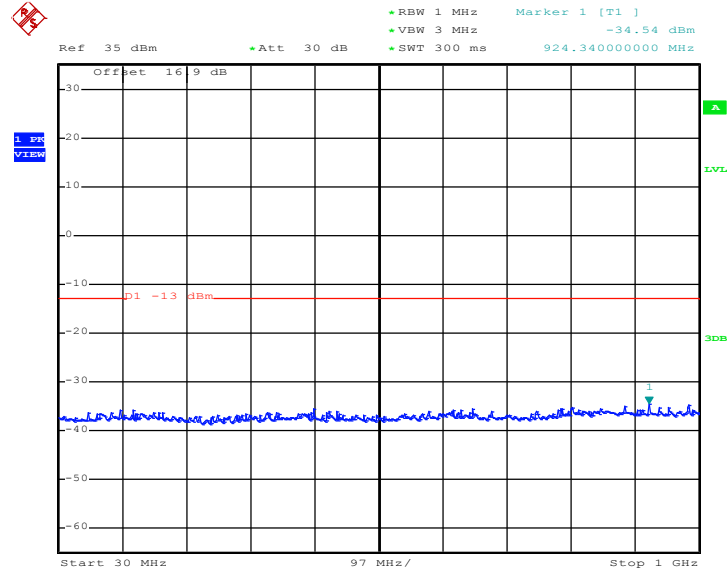

Date: 17.OCT.2014 21:43:30

Conducted Spurious Emission Plot between 1GHz ~ 3GHz

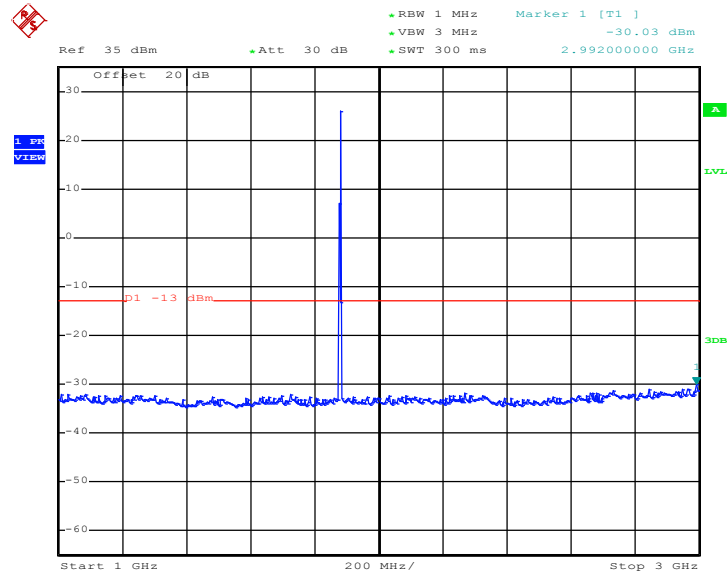

Date: 17.OCT.2014 21:43:38



### Conducted Spurious Emission Plot between 3GHz ~ 7GHz

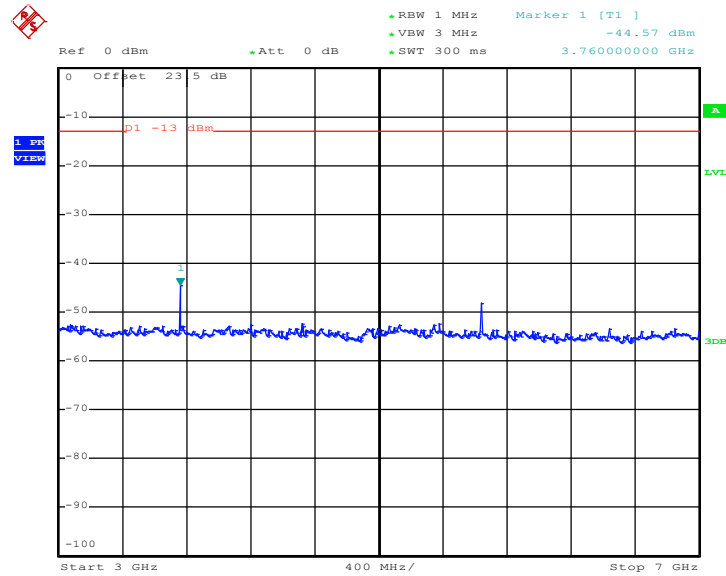

Date: 17.OCT.2014 21:43:55

### Conducted Spurious Emission Plot between 7GHz ~ 13.6GHz

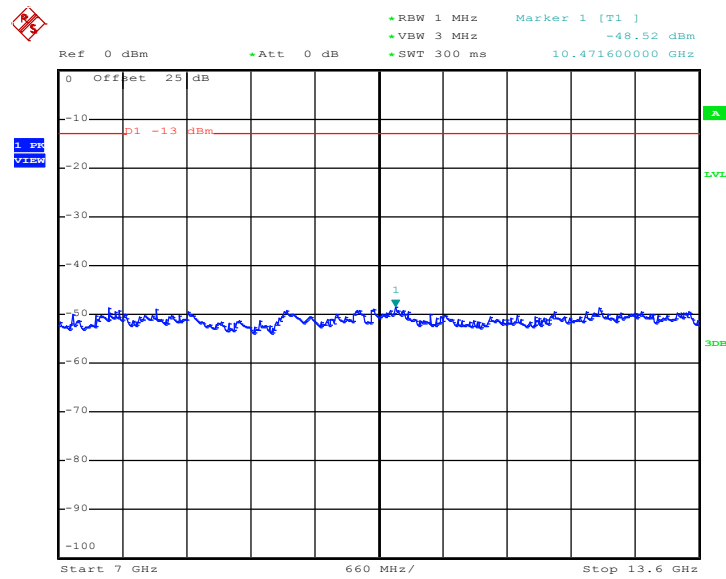

Date: 17.OCT.2014 21:44:03



Conducted Spurious Emission Plot between 13.6GHz ~ 19.1GHz

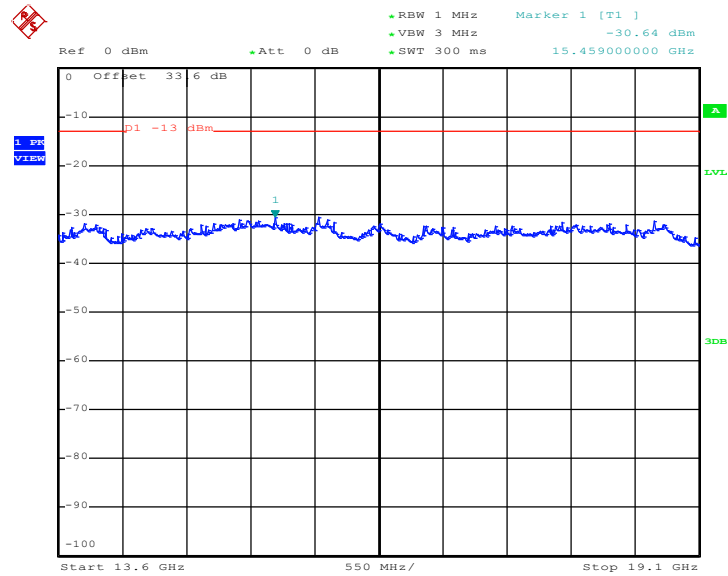

Date: 17.OCT.2014 21:44:12



Band :	GSM1900	Channel :	CH810
Test Mode :	EDGE class 8 Link (8PSK)	Frequency :	1909.8 MHz

Conducted Spurious Emission Plot between 30MHz ~ 1GHz

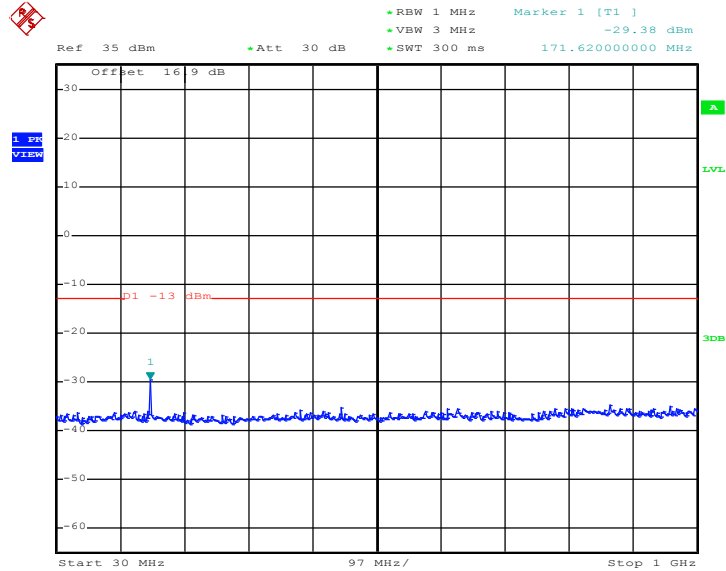

Date: 17.OCT.2014 21:33:45

Conducted Spurious Emission Plot between 1GHz ~ 3GHz

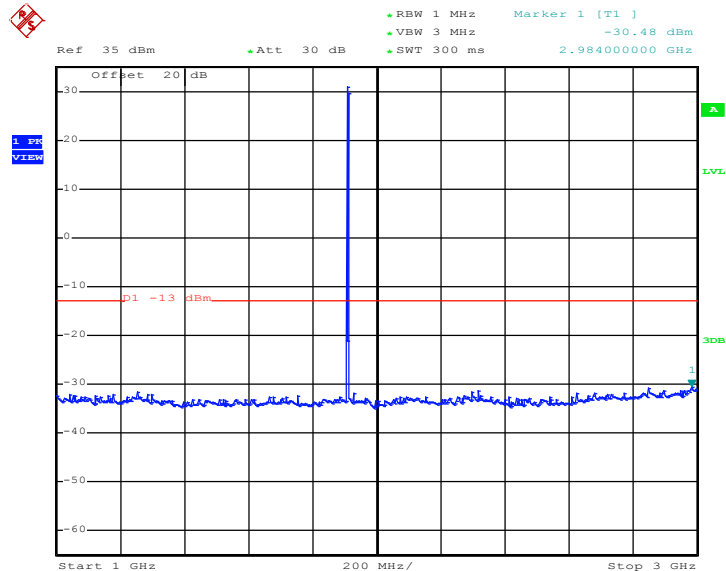

Date: 17.OCT.2014 21:33:54



### Conducted Spurious Emission Plot between 3GHz ~ 7GHz

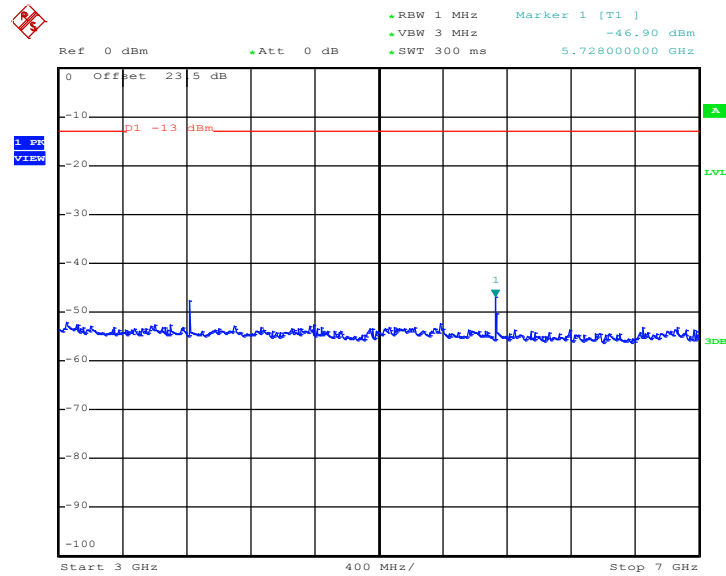

Date: 17.OCT.2014 21:34:15

### Conducted Spurious Emission Plot between 7GHz ~ 13.6GHz

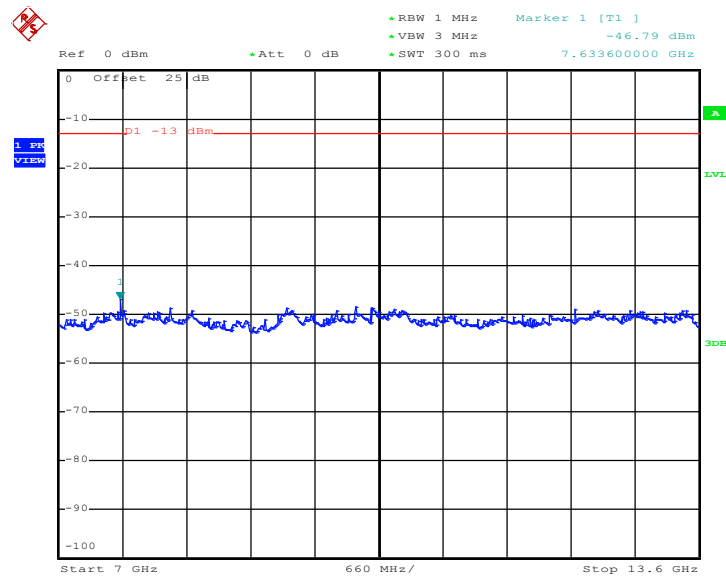

Date: 17.OCT.2014 21:34:24



Conducted Spurious Emission Plot between 13.6GHz ~ 19.1GHz

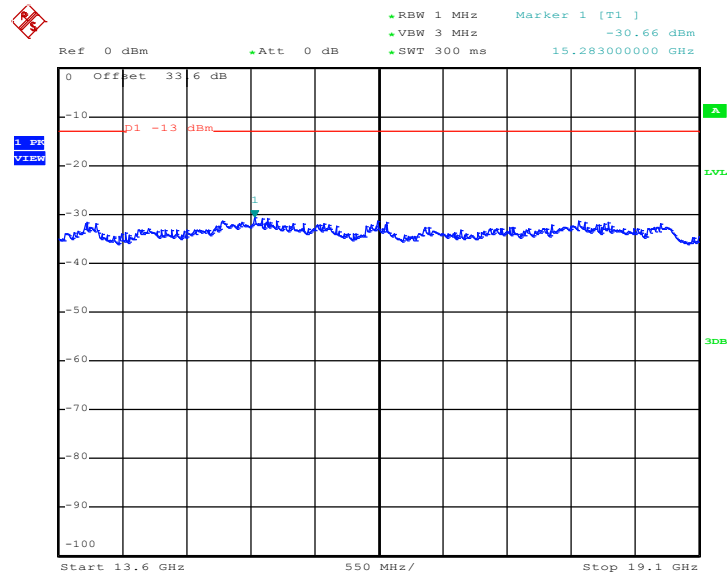

Date: 17.OCT.2014 21:34:32



<b>Band :</b>	WCDMA Band V	<b>Channel :</b>	CH4132
<b>Test Mode :</b>	RMC 12.2Kbps Link (QPSK)	<b>Frequency :</b>	826.4 MHz

Conducted Spurious Emission Plot between 30MHz ~ 1GHz

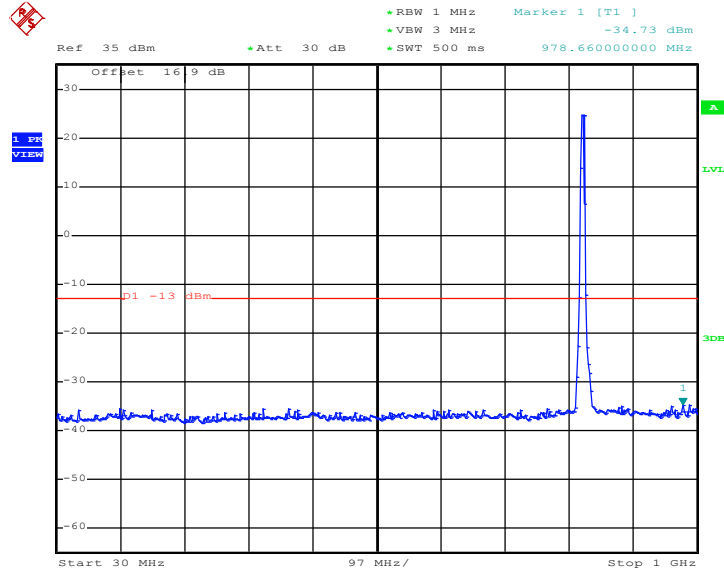

Date: 17.OCT.2014 20:27:56

Conducted Spurious Emission Plot between 1GHz ~ 3GHz

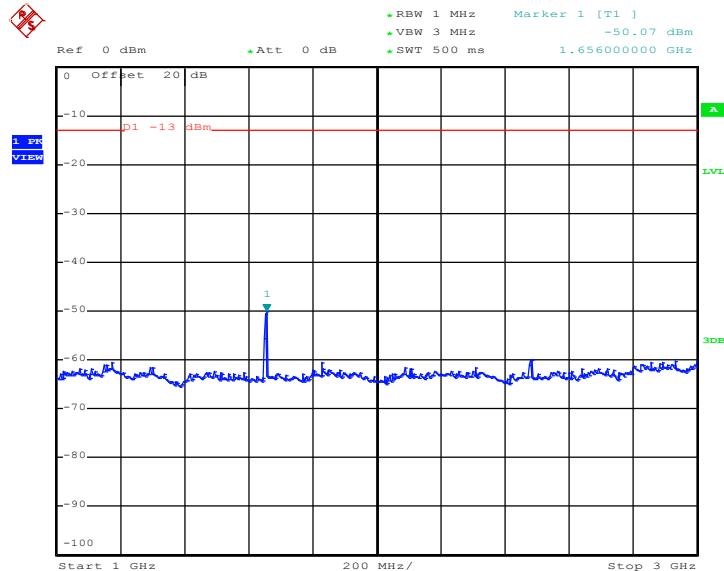

Date: 17.OCT.2014 20:28:09



Conducted Spurious Emission Plot between 3GHz ~ 7GHz

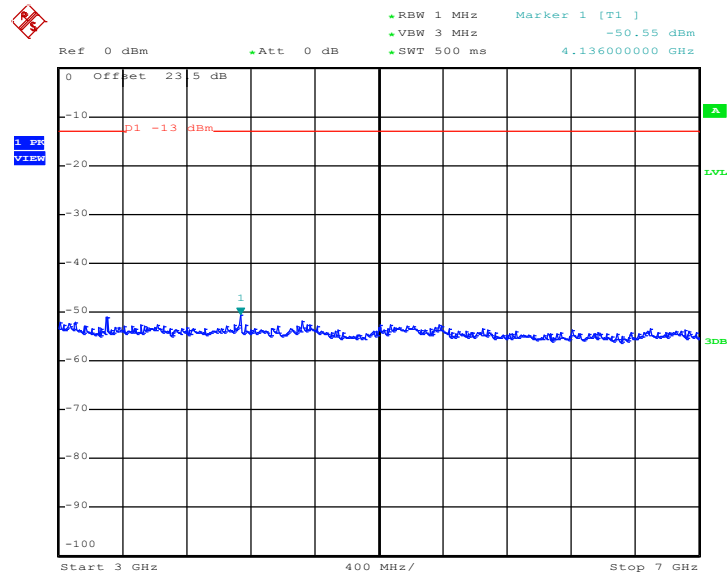

Date: 17.OCT.2014 20:28:18

Conducted Spurious Emission Plot between 7GHz ~ 9GHz

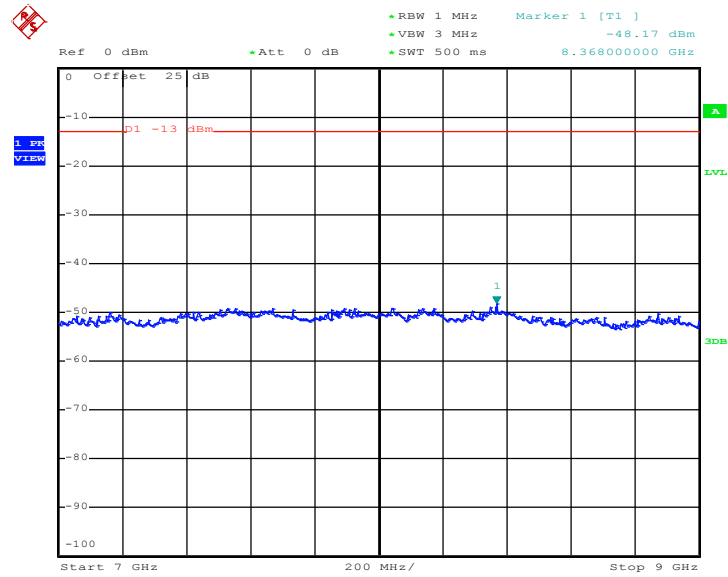

Date: 17.OCT.2014 20:28:26



<b>Band :</b>	WCDMA Band V	<b>Channel :</b>	CH4182
<b>Test Mode :</b>	RMC 12.2Kbps Link (QPSK)	<b>Frequency :</b>	836.4 MHz

Conducted Spurious Emission Plot between 30MHz ~ 1GHz

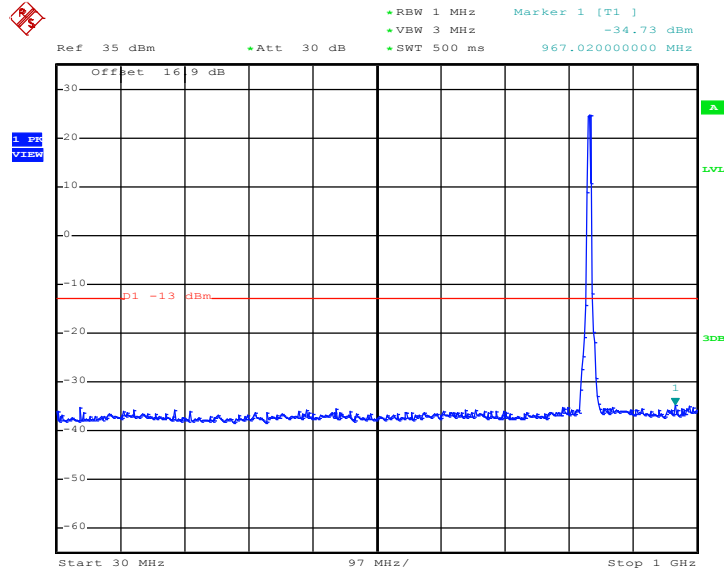

Date: 17.OCT.2014 20:29:13

Conducted Spurious Emission Plot between 1GHz ~ 3GHz

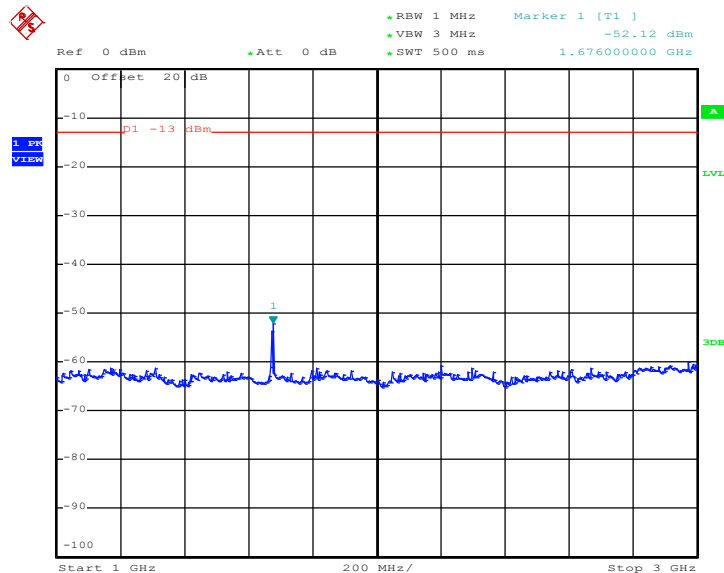

Date: 17.OCT.2014 20:29:42



### Conducted Spurious Emission Plot between 3GHz ~ 7GHz

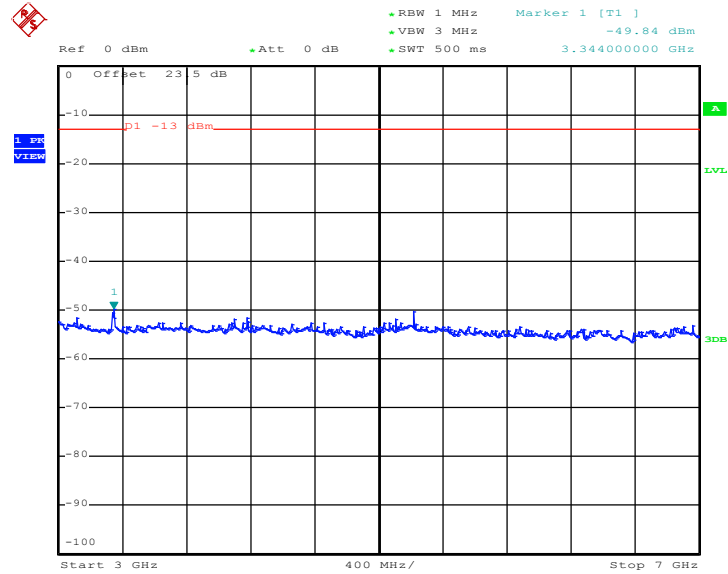

Date: 17.OCT.2014 20:29:50

### Conducted Spurious Emission Plot between 7GHz ~ 9GHz

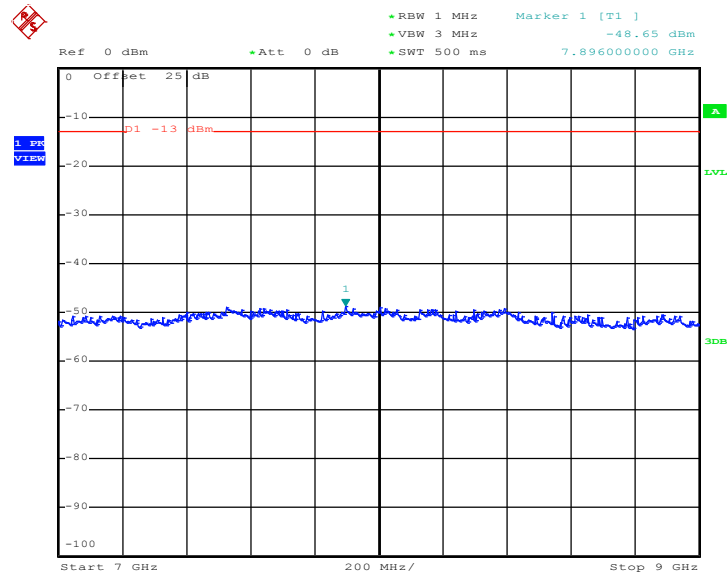

Date: 17.OCT.2014 20:29:58



Band :	WCDMA Band V	Channel :	CH4233
Test Mode :	RMC 12.2Kbps Link (QPSK)	Frequency :	846.6 MHz

Conducted Spurious Emission Plot between 30MHz ~ 1GHz

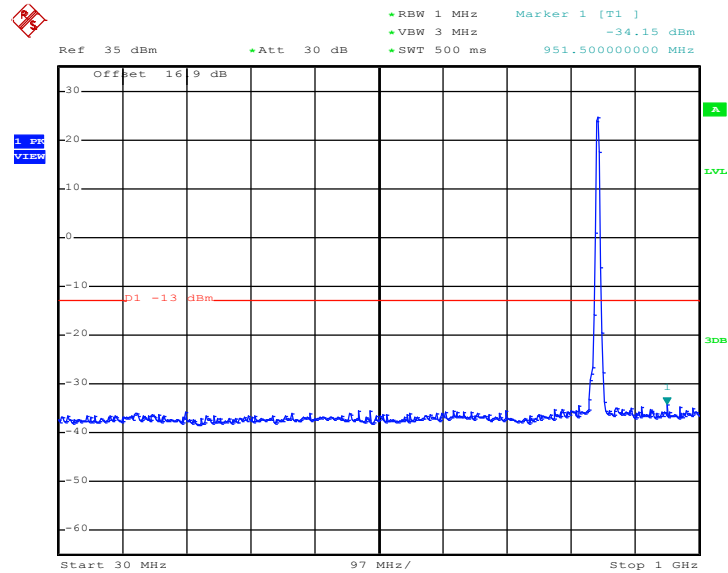

Date: 17.OCT.2014 20:25:31

Conducted Spurious Emission Plot between 1GHz ~ 3GHz

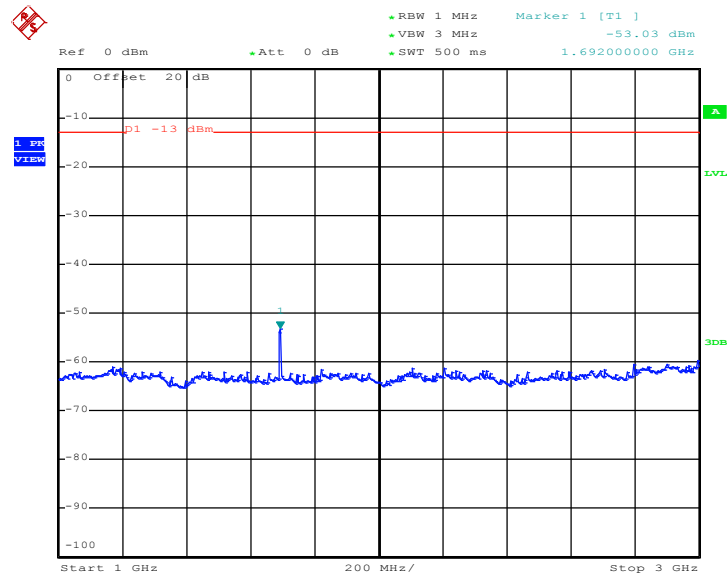

Date: 17.OCT.2014 20:25:44



### Conducted Spurious Emission Plot between 3GHz ~ 7GHz

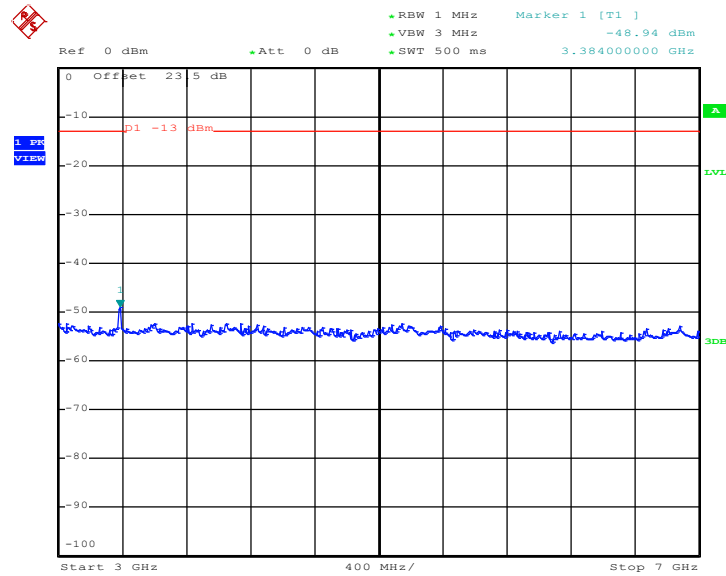

Date: 17.OCT.2014 20:25:53

### Conducted Spurious Emission Plot between 7GHz ~ 9GHz

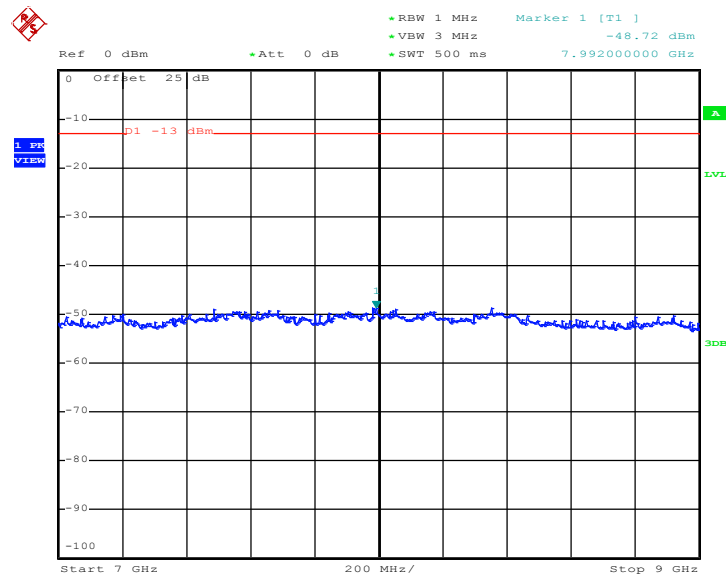

Date: 17.OCT.2014 20:26:01



<b>Band :</b>	WCDMA Band II	<b>Channel :</b>	CH9262
<b>Test Mode :</b>	RMC 12.2Kbps Link (QPSK)	<b>Frequency :</b>	1852.4 MHz

Conducted Spurious Emission Plot between 30MHz ~ 1GHz

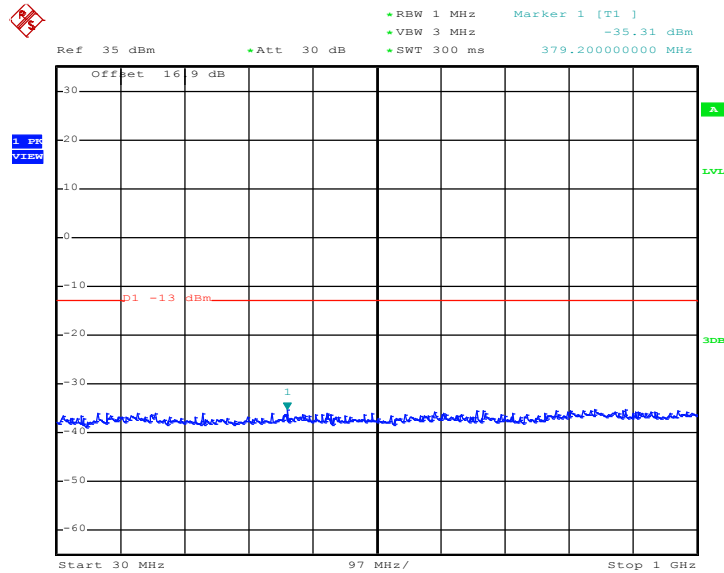

Date: 17.OCT.2014 22:13:44

Conducted Spurious Emission Plot between 1GHz ~ 3GHz

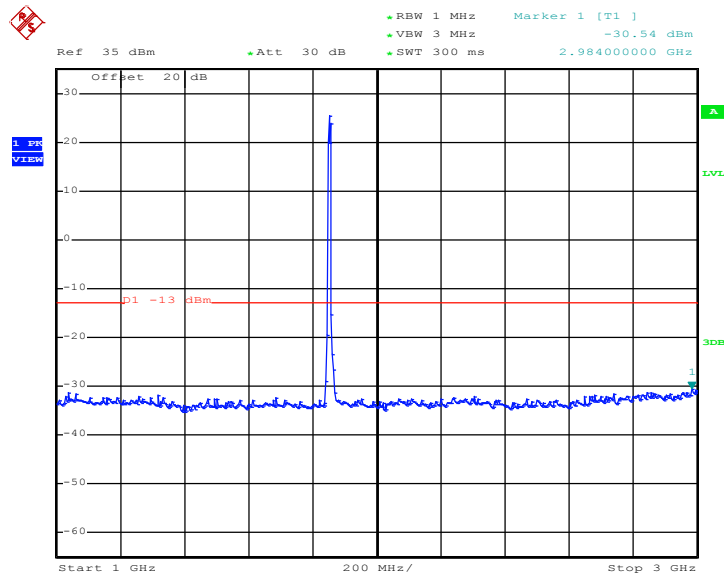

Date: 17.OCT.2014 22:13:52



### Conducted Spurious Emission Plot between 3GHz ~ 7GHz

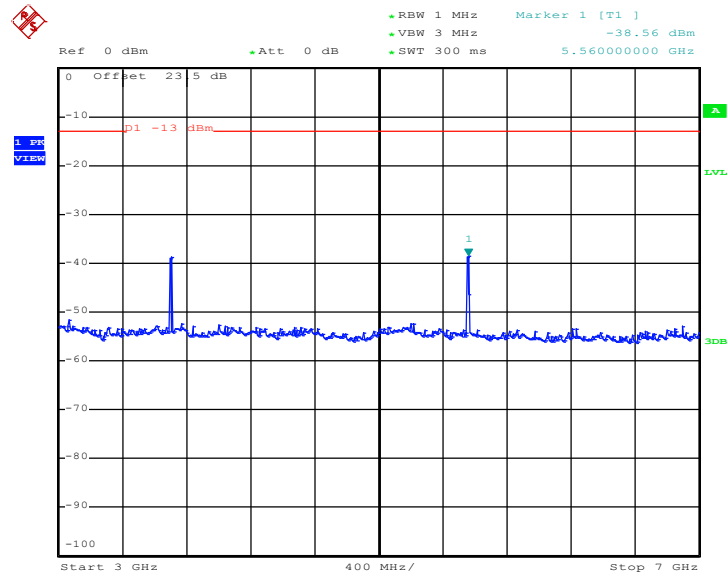

Date: 17.OCT.2014 22:14:04

### Conducted Spurious Emission Plot between 7GHz ~ 13.6GHz

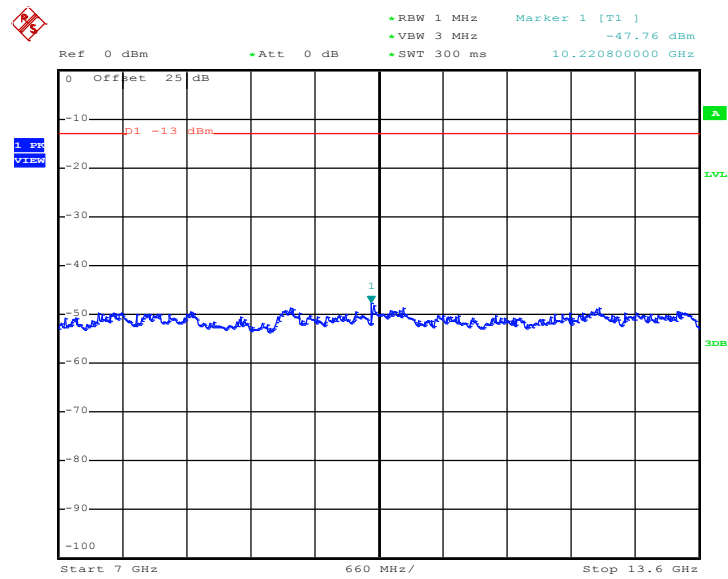

Date: 17.OCT.2014 22:14:13



Conducted Spurious Emission Plot between 13.6GHz ~ 19.1GHz

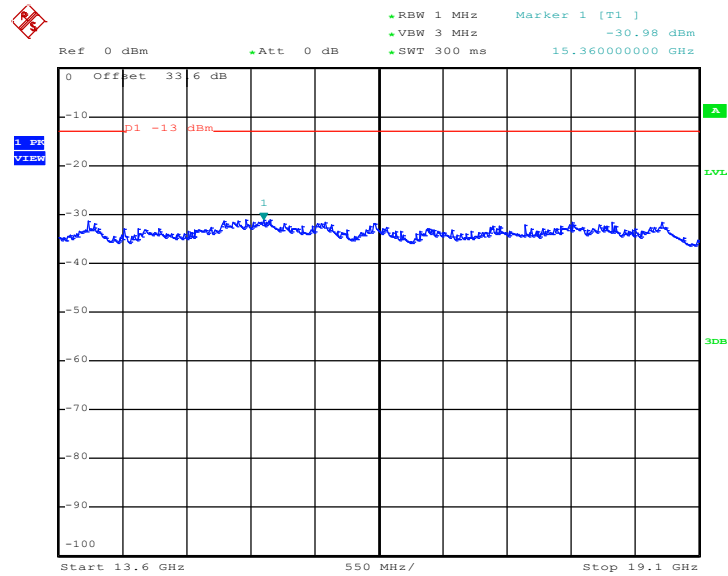

Date: 17.OCT.2014 22:14:21



<b>Band :</b>	WCDMA Band II	<b>Channel :</b>	CH9400
<b>Test Mode :</b>	RMC 12.2Kbps Link (QPSK)	<b>Frequency :</b>	1880.0 MHz

Conducted Spurious Emission Plot between 30MHz ~ 1GHz

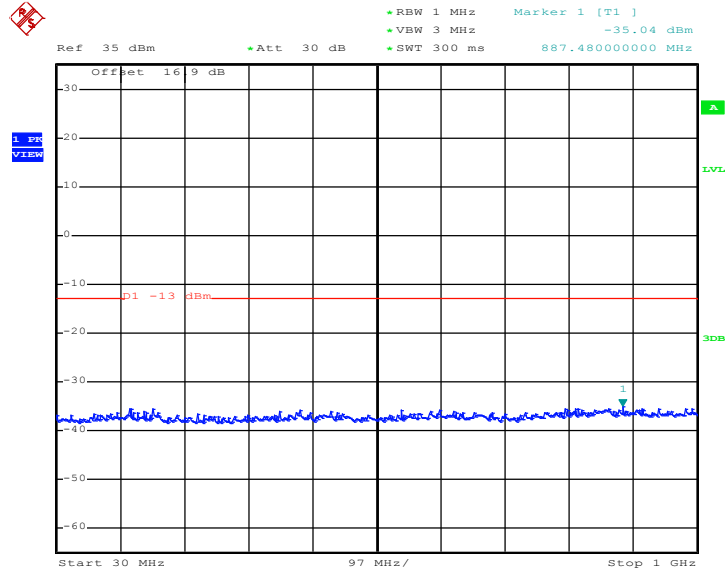

Date: 17.OCT.2014 22:15:47

Conducted Spurious Emission Plot between 1GHz ~ 3GHz

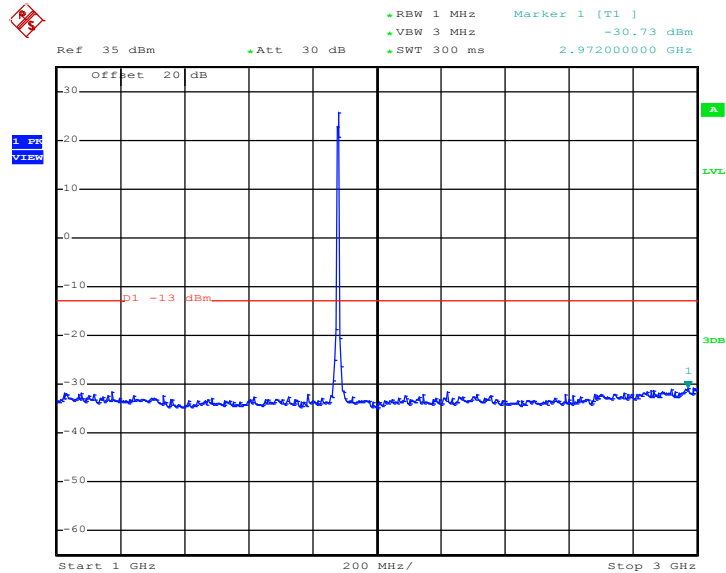

Date: 17.OCT.2014 22:15:55



### Conducted Spurious Emission Plot between 3GHz ~ 7GHz

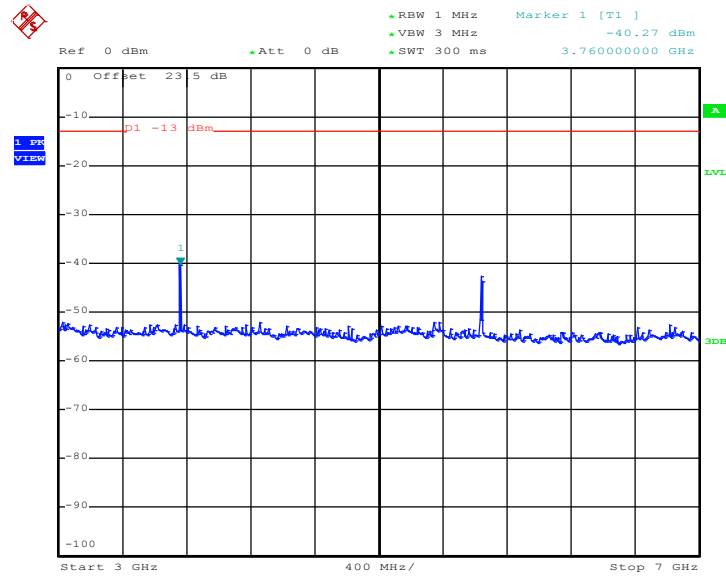

Date: 17.OCT.2014 22:16:08

### Conducted Spurious Emission Plot between 7GHz ~ 13.6GHz

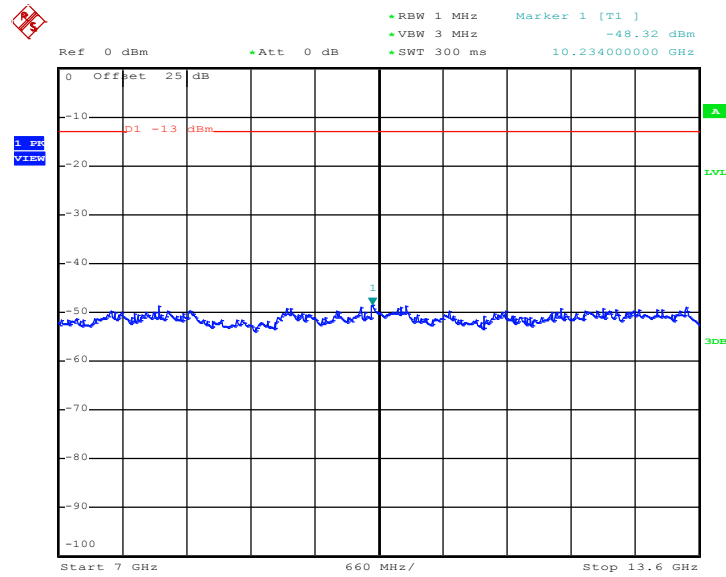

Date: 17.OCT.2014 22:16:17



Conducted Spurious Emission Plot between 13.6GHz ~ 19.1GHz

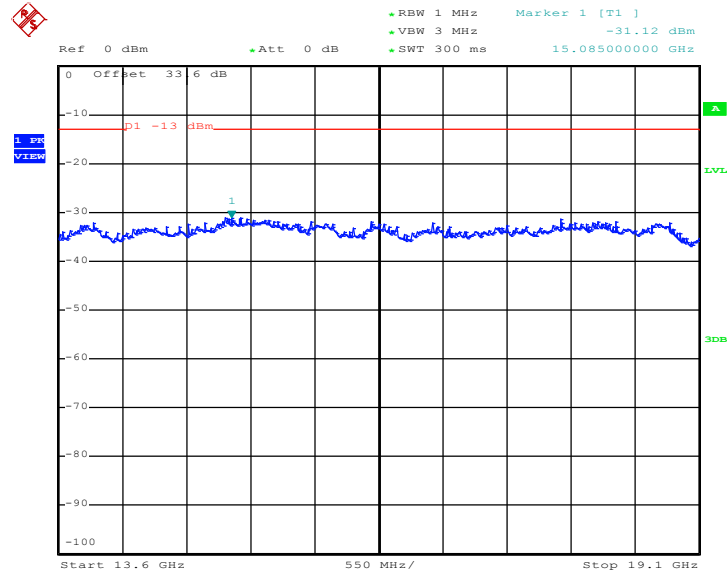

Date: 17.OCT.2014 22:16:25



<b>Band :</b>	WCDMA Band II	<b>Channel :</b>	CH9538
<b>Test Mode :</b>	RMC 12.2Kbps Link (QPSK)	<b>Frequency :</b>	1907.6 MHz

Conducted Spurious Emission Plot between 30MHz ~ 1GHz

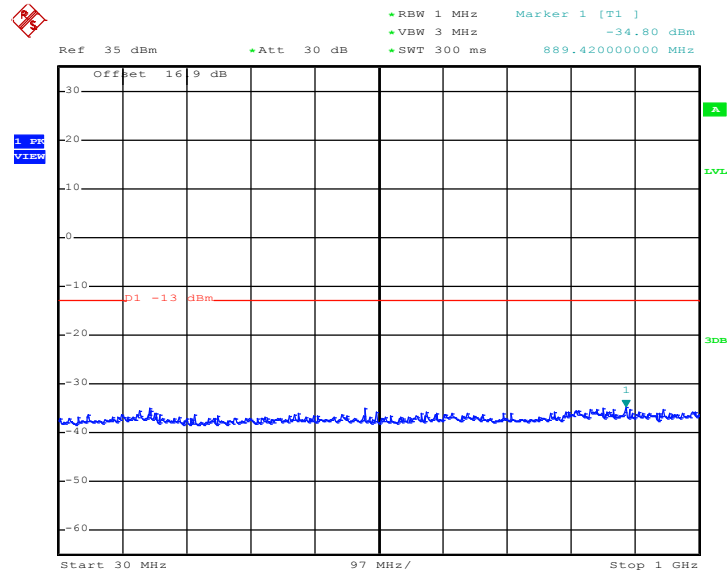

Date: 17.OCT.2014 22:12:01

Conducted Spurious Emission Plot between 1GHz ~ 3GHz

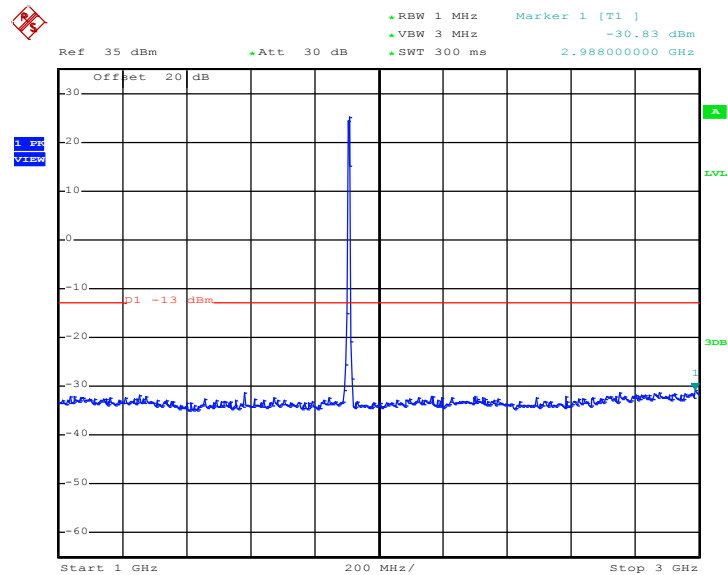

Date: 17.OCT.2014 22:12:10





Conducted Spurious Emission Plot between 13.6GHz ~ 19.1GHz

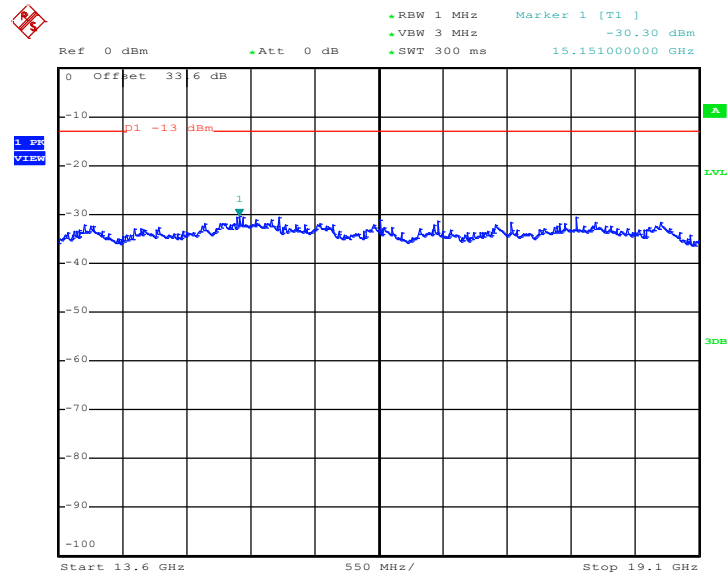

Date: 17.OCT.2014 22:12:41



### 3.7 Field Strength of Spurious Radiation Measurement

#### 3.7.1 Description of Field Strength of Spurious Radiated Measurement

The power of any emission outside of the authorized operating frequency ranges must be attenuated below the transmitter power (P) by a factor of at least  $43 + 10 \log (P)$  dB. The spectrum is scanned from 30 MHz up to a frequency including its 10th harmonic.

#### 3.7.2 Measuring Instruments

The measuring equipment is listed in the section 4 of this test report.

#### 3.7.3 Test Procedures

1. The testing follows FCC KDB 971168 v02r02 Section 5.8 and ANSI / TIA-603-C-2004 Section 2.2.12.
2. The EUT was placed on a rotatable wooden table 0.8 meters above the ground.
3. The EUT was set 3 meters from the receiving antenna, which was mounted on the antenna tower.
4. The table was rotated 360 degrees to determine the position of the highest spurious emission.
5. The height of the receiving antenna is varied between one meter and four meters to search for the maximum spurious emission for both horizontal and vertical polarizations.
6. Make the measurement with the spectrum analyzer's RBW = 1MHz, VBW = 3MHz, taking record of maximum spurious emission.
7. A horn antenna was substituted in place of the EUT and was driven by a signal generator.
8. Tune the output power of signal generator to the same emission level with EUT maximum spurious emission.
9. Taking the record of output power at antenna port.
10. Repeat step 7 to step 8 for another polarization.
11.  $EIRP \text{ (dBm)} = S.G. \text{ Power} - Tx \text{ Cable Loss} + Tx \text{ Antenna Gain}$
12.  $ERP \text{ (dBm)} = EIRP - 2.15$
13. The RF fundamental frequency should be excluded against the limit line in the operating frequency band.
14. The limit line is derived from  $43 + 10\log(P)$  dB below the transmitter power P(Watts)  
=  $P(W) - [43 + 10\log(P)] \text{ (dB)}$   
=  $[30 + 10\log(P)] \text{ (dBm)} - [43 + 10\log(P)] \text{ (dB)}$   
= -13dBm.

### 3.7.4 Test Setup

For radiated emissions from 30MHz to 1GHz

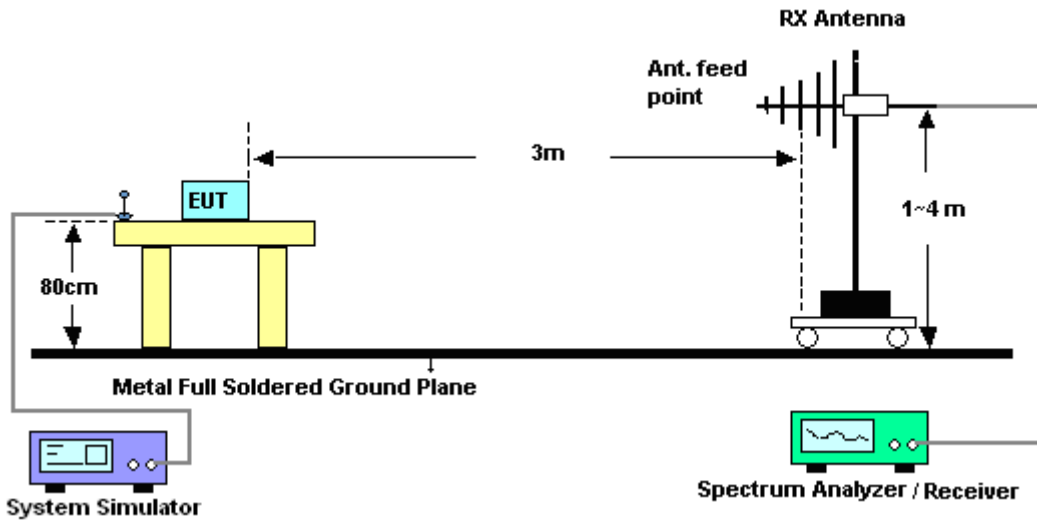

For radiated emissions above 1GHz

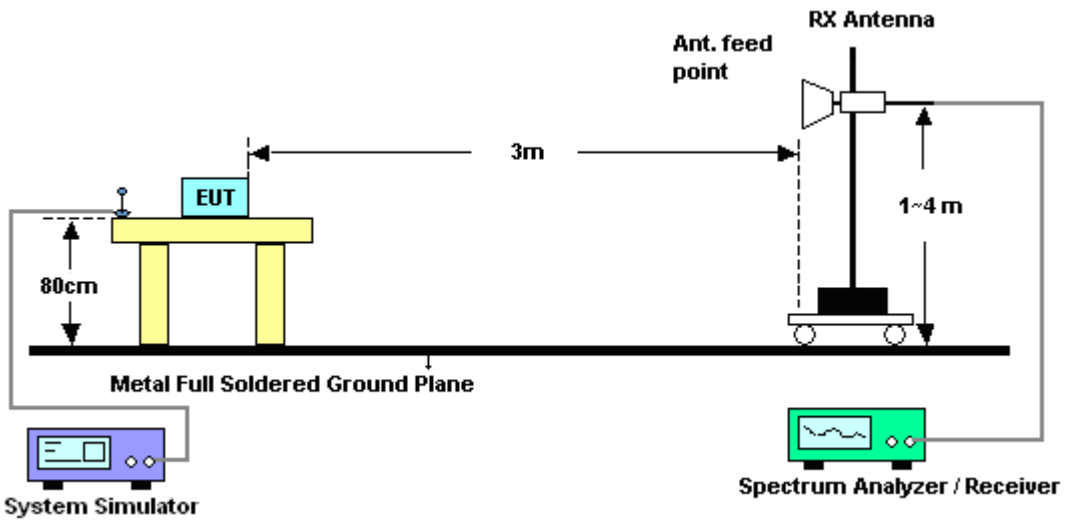



3.7.5 Test Result of Field Strength of Spurious Radiated

<Low Channel>

<b>Band :</b>	GSM850				<b>Temperature :</b>	23~24°C			
<b>Test Mode :</b>	GPRS class 8 Link (GMSK)				<b>Relative Humidity :</b>	46~48%			
<b>Test Engineer :</b>	Derreck Chen and Nick Yu				<b>Polarization :</b>	Horizontal			
<b>Remark :</b>	Spurious emissions within 30-1000MHz were found more than 20dB below limit line.								
Frequency ( MHz )	ERP ( dBm )	Limit ( dBm )	Over Limit ( dB )	SPA Reading ( dBm )	S.G. Power ( dBm )	TX Cable loss ( dB )	TX Antenna Gain ( dBi )	Polarization ( H/V )	Result
1648	-47.54	-13	-34.54	-58.98	-49.3	0.98	4.89	H	Pass
2472	-39.62	-13	-26.62	-55.41	-41.5	1.28	5.32	H	Pass
3297	-49.68	-13	-36.68	-66.4	-53.1	1.54	7.11	H	Pass

<b>Band :</b>	GSM850				<b>Temperature :</b>	23~24°C			
<b>Test Mode :</b>	GPRS class 8 Link (GMSK)				<b>Relative Humidity :</b>	46~48%			
<b>Test Engineer :</b>	Derreck Chen and Nick Yu				<b>Polarization :</b>	Vertical			
<b>Remark :</b>	Spurious emissions within 30-1000MHz were found more than 20dB below limit line.								
Frequency ( MHz )	ERP ( dBm )	Limit ( dBm )	Over Limit ( dB )	SPA Reading ( dBm )	S.G. Power ( dBm )	TX Cable loss ( dB )	TX Antenna Gain ( dBi )	Polarization ( H/V )	Result
1648	-40.34	-13	-27.34	-54.04	-42.1	0.98	4.89	V	Pass
2472	-39.62	-13	-26.62	-55.98	-41.5	1.28	5.32	V	Pass
3297	-47.78	-13	-34.78	-66.29	-51.2	1.54	7.11	V	Pass



<Middle Channel>

<b>Band :</b>	GSM850		<b>Temperature :</b>	23~24°C					
<b>Test Mode :</b>	GPRS class 8 Link (GMSK)		<b>Relative Humidity :</b>	46~48%					
<b>Test Engineer :</b>	Derreck Chen and Nick Yu		<b>Polarization :</b>	Horizontal					
<b>Remark :</b>	Spurious emissions within 30-1000MHz were found more than 20dB below limit line.								
Frequency ( MHz )	ERP ( dBm )	Limit ( dBm )	Over Limit ( dB )	SPA Reading ( dBm )	S.G. Power ( dBm )	TX Cable loss ( dB )	TX Antenna Gain ( dBi )	Polarization ( H/V )	Result
1672	-45.22	-13	-32.22	-56.97	-46.9	0.99	4.82	H	Pass
2512	-36.93	-13	-23.93	-53.21	-38.9	1.29	5.41	H	Pass
3345	-50.59	-13	-37.59	-66.94	-54.2	1.56	7.32	H	Pass

<b>Band :</b>	GSM850		<b>Temperature :</b>	23~24°C					
<b>Test Mode :</b>	GPRS class 8 Link (GMSK)		<b>Relative Humidity :</b>	46~48%					
<b>Test Engineer :</b>	Derreck Chen and Nick Yu		<b>Polarization :</b>	Vertical					
<b>Remark :</b>	Spurious emissions within 30-1000MHz were found more than 20dB below limit line.								
Frequency ( MHz )	ERP ( dBm )	Limit ( dBm )	Over Limit ( dB )	SPA Reading ( dBm )	S.G. Power ( dBm )	TX Cable loss ( dB )	TX Antenna Gain ( dBi )	Polarization ( H/V )	Result
1672	-39.82	-13	-26.82	-53.53	-41.5	0.99	4.82	V	Pass
2509	-37.14	-13	-24.14	-53.47	-39.1	1.29	5.41	V	Pass
3345	-48.49	-13	-35.49	-66.92	-52.1	1.56	7.32	V	Pass



<High Channel>

<b>Band :</b>	GSM850		<b>Temperature :</b>	23~24°C					
<b>Test Mode :</b>	GPRS class 8 Link (GMSK)		<b>Relative Humidity :</b>	46~48%					
<b>Test Engineer :</b>	Derreck Chen and Nick Yu		<b>Polarization :</b>	Horizontal					
<b>Remark :</b>	Spurious emissions within 30-1000MHz were found more than 20dB below limit line.								
Frequency ( MHz )	ERP ( dBm )	Limit ( dBm )	Over Limit ( dB )	SPA Reading ( dBm )	S.G. Power ( dBm )	TX Cable loss ( dB )	TX Antenna Gain ( dBi )	Polarization ( H/V )	Result
1696	-46.40	-13	-33.40	-58.18	-48	1.00	4.75	H	Pass
2544	-36.12	-13	-23.12	-52.19	-38.1	1.30	5.44	H	Pass
3395	-49.78	-13	-36.78	-66.88	-53.6	1.57	7.54	H	Pass

<b>Band :</b>	GSM850		<b>Temperature :</b>	23~24°C					
<b>Test Mode :</b>	GPRS class 8 Link (GMSK)		<b>Relative Humidity :</b>	46~48%					
<b>Test Engineer :</b>	Derreck Chen and Nick Yu		<b>Polarization :</b>	Vertical					
<b>Remark :</b>	Spurious emissions within 30-1000MHz were found more than 20dB below limit line.								
Frequency ( MHz )	ERP ( dBm )	Limit ( dBm )	Over Limit ( dB )	SPA Reading ( dBm )	S.G. Power ( dBm )	TX Cable loss ( dB )	TX Antenna Gain ( dBi )	Polarization ( H/V )	Result
1696	-43.50	-13	-30.50	-57.51	-45.1	1.00	4.75	V	Pass
2544	-36.62	-13	-23.62	-53.24	-38.6	1.30	5.44	V	Pass
3395	-48.28	-13	-35.28	-66.33	-52.1	1.57	7.54	V	Pass



<Low Channel>

<b>Band :</b>	GSM850		<b>Temperature :</b>	23~24°C					
<b>Test Mode :</b>	EDGE class 8 Link (8PSK)		<b>Relative Humidity :</b>	46~48%					
<b>Test Engineer :</b>	Derreck Chen and Nick Yu		<b>Polarization :</b>	Horizontal					
<b>Remark :</b>	Spurious emissions within 30-1000MHz were found more than 20dB below limit line.								
Frequency ( MHz )	ERP ( dBm )	Limit ( dBm )	Over Limit ( dB )	SPA Reading ( dBm )	S.G. Power ( dBm )	TX Cable loss ( dB )	TX Antenna Gain ( dBi )	Polarization ( H/V )	Result
1648	-52.04	-13	-39.04	-63.25	-53.8	0.98	4.89	H	Pass
2472	-47.42	-13	-34.42	-63.24	-49.3	1.28	5.32	H	Pass
3298	-49.68	-13	-36.68	-66.28	-53.1	1.54	7.11	H	Pass

<b>Band :</b>	GSM850		<b>Temperature :</b>	23~24°C					
<b>Test Mode :</b>	EDGE class 8 Link (8PSK)		<b>Relative Humidity :</b>	46~48%					
<b>Test Engineer :</b>	Derreck Chen and Nick Yu		<b>Polarization :</b>	Vertical					
<b>Remark :</b>	Spurious emissions within 30-1000MHz were found more than 20dB below limit line.								
Frequency ( MHz )	ERP ( dBm )	Limit ( dBm )	Over Limit ( dB )	SPA Reading ( dBm )	S.G. Power ( dBm )	TX Cable loss ( dB )	TX Antenna Gain ( dBi )	Polarization ( H/V )	Result
1648	-45.34	-13	-32.34	-58.72	-47.1	0.98	4.89	V	Pass
2472	-46.72	-13	-33.72	-62.88	-48.6	1.28	5.32	V	Pass
3298	-47.48	-13	-34.48	-66.05	-50.9	1.54	7.11	V	Pass



<Middle Channel>

<b>Band :</b>	GSM850		<b>Temperature :</b>	23~24°C					
<b>Test Mode :</b>	EDGE class 8 Link (8PSK)		<b>Relative Humidity :</b>	46~48%					
<b>Test Engineer :</b>	Derreck Chen and Nick Yu		<b>Polarization :</b>	Horizontal					
<b>Remark :</b>	Spurious emissions within 30-1000MHz were found more than 20dB below limit line.								
Frequency ( MHz )	ERP ( dBm )	Limit ( dBm )	Over Limit ( dB )	SPA Reading ( dBm )	S.G. Power ( dBm )	TX Cable loss ( dB )	TX Antenna Gain ( dBi )	Polarization ( H/V )	Result
1672	-53.82	-13	-40.82	-65.01	-55.5	0.99	4.82	H	Pass
2512	-46.33	-13	-33.33	-62.15	-48.3	1.29	5.41	H	Pass
3345	-49.29	-13	-36.29	-66.58	-52.9	1.56	7.32	H	Pass

<b>Band :</b>	GSM850		<b>Temperature :</b>	23~24°C					
<b>Test Mode :</b>	EDGE class 8 Link (8PSK)		<b>Relative Humidity :</b>	46~48%					
<b>Test Engineer :</b>	Derreck Chen and Nick Yu		<b>Polarization :</b>	Vertical					
<b>Remark :</b>	Spurious emissions within 30-1000MHz were found more than 20dB below limit line.								
Frequency ( MHz )	ERP ( dBm )	Limit ( dBm )	Over Limit ( dB )	SPA Reading ( dBm )	S.G. Power ( dBm )	TX Cable loss ( dB )	TX Antenna Gain ( dBi )	Polarization ( H/V )	Result
1672	-51.12	-13	-38.12	-65.38	-52.8	0.99	4.82	V	Pass
2512	-44.23	-13	-31.23	-61.05	-46.2	1.29	5.41	V	Pass
3345	-48.59	-13	-35.59	-66.67	-52.2	1.56	7.32	V	Pass



<High Channel>

<b>Band :</b>	GSM850		<b>Temperature :</b>	23~24°C					
<b>Test Mode :</b>	EDGE class 8 Link (8PSK)		<b>Relative Humidity :</b>	46~48%					
<b>Test Engineer :</b>	Derreck Chen and Nick Yu		<b>Polarization :</b>	Horizontal					
<b>Remark :</b>	Spurious emissions within 30-1000MHz were found more than 20dB below limit line.								
Frequency ( MHz )	ERP ( dBm )	Limit ( dBm )	Over Limit ( dB )	SPA Reading ( dBm )	S.G. Power ( dBm )	TX Cable loss ( dB )	TX Antenna Gain ( dBi )	Polarization ( H/V )	Result
1696	-53.50	-13	-40.50	-65.07	-55.1	1.00	4.75	H	Pass
2544	-41.62	-13	-28.62	-57.61	-43.6	1.30	5.44	H	Pass
3392	-49.10	-13	-36.10	-66.43	-52.9	1.57	7.52	H	Pass

<b>Band :</b>	GSM850		<b>Temperature :</b>	23~24°C					
<b>Test Mode :</b>	EDGE class 8 Link (8PSK)		<b>Relative Humidity :</b>	46~48%					
<b>Test Engineer :</b>	Derreck Chen and Nick Yu		<b>Polarization :</b>	Vertical					
<b>Remark :</b>	Spurious emissions within 30-1000MHz were found more than 20dB below limit line.								
Frequency ( MHz )	ERP ( dBm )	Limit ( dBm )	Over Limit ( dB )	SPA Reading ( dBm )	S.G. Power ( dBm )	TX Cable loss ( dB )	TX Antenna Gain ( dBi )	Polarization ( H/V )	Result
1696	-51.20	-13	-38.20	-64.87	-52.8	1.00	4.75	V	Pass
2544	-41.77	-13	-28.77	-58.11	-45.9	1.30	5.44	V	Pass
3392	-48.15	-13	-35.15	-66.41	-54.1	1.57	7.52	V	Pass



<Low Channel>

<b>Band :</b>	GSM1900		<b>Temperature :</b>	23~24°C					
<b>Test Mode :</b>	GSM Link (GMSK)		<b>Relative Humidity :</b>	46~48%					
<b>Test Engineer :</b>	Derreck Chen and Nick Yu		<b>Polarization :</b>	Horizontal					
<b>Remark :</b>	Spurious emissions within 30-1000MHz were found more than 20dB below limit line.								
Frequency ( MHz )	EIRP ( dBm )	Limit ( dBm )	Over Limit ( dB )	SPA Reading ( dBm )	S.G. Power ( dBm )	TX Cable loss ( dB )	TX Antenna Gain ( dBi )	Polarization ( H/V )	Result
3700	-45.83	-13	-32.83	-63.53	-52.4	1.67	8.24	H	Pass
5548	-34.53	-13	-21.53	-57.25	-41.6	2.65	9.72	H	Pass
7403	-29.95	-13	-16.95	-60.24	-39.1	2.46	11.61	H	Pass

<b>Band :</b>	GSM1900		<b>Temperature :</b>	23~24°C					
<b>Test Mode :</b>	GSM Link (GMSK)		<b>Relative Humidity :</b>	46~48%					
<b>Test Engineer :</b>	Derreck Chen and Nick Yu		<b>Polarization :</b>	Vertical					
<b>Remark :</b>	Spurious emissions within 30-1000MHz were found more than 20dB below limit line.								
Frequency ( MHz )	EIRP ( dBm )	Limit ( dBm )	Over Limit ( dB )	SPA Reading ( dBm )	S.G. Power ( dBm )	TX Cable loss ( dB )	TX Antenna Gain ( dBi )	Polarization ( H/V )	Result
3700	-46.13	-13	-33.13	-64.87	-52.7	1.67	8.24	V	Pass
5548	-34.53	-13	-21.53	-57.53	-41.6	2.65	9.72	V	Pass
7403	-35.45	-13	-22.45	-64.87	-44.6	2.46	11.61	V	Pass



<Middle Channel>

<b>Band :</b>	GSM1900				<b>Temperature :</b>	23~24°C				
<b>Test Mode :</b>	GSM Link (GMSK)				<b>Relative Humidity :</b>	46~48%				
<b>Test Engineer :</b>	Derreck Chen and Nick Yu				<b>Polarization :</b>	Horizontal				
<b>Remark :</b>	Spurious emissions within 30-1000MHz were found more than 20dB below limit line.									
Frequency ( MHz )	EIRP ( dBm )	Limit ( dBm )	Over Limit ( dB )	SPA Reading ( dBm )	S.G. Power ( dBm )	TX Cable loss ( dB )	TX Antenna Gain ( dBi )	Polarization ( H/V )	Result	
3756	-44.58	-13	-31.58	-62.58	-51.2	1.68	8.31	H	Pass	
5639	-35.05	-13	-22.05	-58.74	-42.1	2.71	9.76	H	Pass	
7522	-28.11	-13	-15.11	-57.8	-37.5	2.42	11.81	H	Pass	
9398	-33.23	-13	-20.23	-62.58	-43.2	2.57	12.54	H	Pass	
11282.5	-30.50	-13	-17.50	-62.57	-40.2	2.68	12.39	H	Pass	

<b>Band :</b>	GSM1900				<b>Temperature :</b>	23~24°C				
<b>Test Mode :</b>	GSM Link (GMSK)				<b>Relative Humidity :</b>	46~48%				
<b>Test Engineer :</b>	Derreck Chen and Nick Yu				<b>Polarization :</b>	Vertical				
<b>Remark :</b>	Spurious emissions within 30-1000MHz were found more than 20dB below limit line.									
Frequency ( MHz )	EIRP ( dBm )	Limit ( dBm )	Over Limit ( dB )	SPA Reading ( dBm )	S.G. Power ( dBm )	TX Cable loss ( dB )	TX Antenna Gain ( dBi )	Polarization ( H/V )	Result	
3756	-45.48	-13	-32.48	-64.5	-52.1	1.68	8.31	V	Pass	
5639	-36.05	-13	-23.05	-59.14	-43.1	2.71	9.76	V	Pass	
7522	-32.01	-13	-19.01	-61.7	-41.4	2.42	11.81	V	Pass	
9398	-33.33	-13	-20.33	-62.35	-43.3	2.57	12.54	V	Pass	
11282.5	-34.40	-13	-21.40	-65.47	-44.1	2.68	12.39	V	Pass	



<High Channel>

<b>Band :</b>	GSM1900				<b>Temperature :</b>	23~24°C			
<b>Test Mode :</b>	GSM Link (GMSK)				<b>Relative Humidity :</b>	46~48%			
<b>Test Engineer :</b>	Derreck Chen and Nick Yu				<b>Polarization :</b>	Horizontal			
<b>Remark :</b>	Spurious emissions within 30-1000MHz were found more than 20dB below limit line.								
Frequency ( MHz )	EIRP ( dBm )	Limit ( dBm )	Over Limit ( dB )	SPA Reading ( dBm )	S.G. Power ( dBm )	TX Cable loss ( dB )	TX Antenna Gain ( dBi )	Polarization ( H/V )	Result
3819	-44.12	-13	-31.12	-63	-50.8	1.70	8.38	H	Pass
5730	-35.17	-13	-22.17	-58.86	-42.2	2.76	9.79	H	Pass
7641	-27.70	-13	-14.70	-56.57	-37.2	2.38	11.88	H	Pass
9552	-32.63	-13	-19.63	-61.78	-42.5	2.60	12.47	H	Pass

<b>Band :</b>	GSM1900				<b>Temperature :</b>	23~24°C			
<b>Test Mode :</b>	GSM Link (GMSK)				<b>Relative Humidity :</b>	46~48%			
<b>Test Engineer :</b>	Derreck Chen and Nick Yu				<b>Polarization :</b>	Vertical			
<b>Remark :</b>	Spurious emissions within 30-1000MHz were found more than 20dB below limit line.								
Frequency ( MHz )	EIRP ( dBm )	Limit ( dBm )	Over Limit ( dB )	SPA Reading ( dBm )	S.G. Power ( dBm )	TX Cable loss ( dB )	TX Antenna Gain ( dBi )	Polarization ( H/V )	Result
3819	-45.42	-13	-32.42	-64.4	-52.1	1.70	8.38	V	Pass
5730	-35.17	-13	-22.17	-58.47	-42.2	2.76	9.79	V	Pass
7641	-31.20	-13	-18.20	-60.01	-40.7	2.38	11.88	V	Pass
9552	-33.93	-13	-20.93	-63.29	-43.8	2.60	12.47	V	Pass



<Low Channel>

<b>Band :</b>	GSM1900		<b>Temperature :</b>	23~24°C					
<b>Test Mode :</b>	EDGE class 8 Link (8PSK)		<b>Relative Humidity :</b>	46~48%					
<b>Test Engineer :</b>	Derreck Chen and Nick Yu		<b>Polarization :</b>	Horizontal					
<b>Remark :</b>	Spurious emissions within 30-1000MHz were found more than 20dB below limit line.								
Frequency ( MHz )	EIRP ( dBm )	Limit ( dBm )	Over Limit ( dB )	SPA Reading ( dBm )	S.G. Power ( dBm )	TX Cable loss ( dB )	TX Antenna Gain ( dBi )	Polarization ( H/V )	Result
3705	-49.02	-13	-36.02	-67	-55.6	1.67	8.25	H	Pass
5548	-39.43	-13	-26.43	-62.78	-46.5	2.65	9.72	H	Pass
7403	-34.75	-13	-21.75	-64.7	-43.9	2.46	11.61	H	Pass

<b>Band :</b>	GSM1900		<b>Temperature :</b>	23~24°C					
<b>Test Mode :</b>	EDGE class 8 Link (8PSK)		<b>Relative Humidity :</b>	46~48%					
<b>Test Engineer :</b>	Derreck Chen and Nick Yu		<b>Polarization :</b>	Vertical					
<b>Remark :</b>	Spurious emissions within 30-1000MHz were found more than 20dB below limit line.								
Frequency ( MHz )	EIRP ( dBm )	Limit ( dBm )	Over Limit ( dB )	SPA Reading ( dBm )	S.G. Power ( dBm )	TX Cable loss ( dB )	TX Antenna Gain ( dBi )	Polarization ( H/V )	Result
3707	-47.32	-13	-34.32	-66.07	-53.9	1.67	8.25	V	Pass
5548	-44.23	-13	-31.23	-67.09	-51.3	2.65	9.72	V	Pass
7403	-38.45	-13	-25.45	-68.01	-47.6	2.46	11.61	V	Pass



<Middle Channel>

<b>Band :</b>	GSM1900		<b>Temperature :</b>	23~24°C					
<b>Test Mode :</b>	EDGE class 8 Link (8PSK)		<b>Relative Humidity :</b>	46~48%					
<b>Test Engineer :</b>	Derreck Chen and Nick Yu		<b>Polarization :</b>	Horizontal					
<b>Remark :</b>	Spurious emissions within 30-1000MHz were found more than 20dB below limit line.								
Frequency ( MHz )	EIRP ( dBm )	Limit ( dBm )	Over Limit ( dB )	SPA Reading ( dBm )	S.G. Power ( dBm )	TX Cable loss ( dB )	TX Antenna Gain ( dBi )	Polarization ( H/V )	Result
3760	-49.27	-13	-36.27	-67.34	-55.9	1.69	8.31	H	Pass
5639	-40.35	-13	-27.35	-63.67	-47.4	2.71	9.76	H	Pass
7522	-34.31	-13	-21.31	-64.32	-43.7	2.42	11.81	H	Pass

<b>Band :</b>	GSM1900		<b>Temperature :</b>	23~24°C					
<b>Test Mode :</b>	EDGE class 8 Link (8PSK)		<b>Relative Humidity :</b>	46~48%					
<b>Test Engineer :</b>	Derreck Chen and Nick Yu		<b>Polarization :</b>	Vertical					
<b>Remark :</b>	Spurious emissions within 30-1000MHz were found more than 20dB below limit line.								
Frequency ( MHz )	EIRP ( dBm )	Limit ( dBm )	Over Limit ( dB )	SPA Reading ( dBm )	S.G. Power ( dBm )	TX Cable loss ( dB )	TX Antenna Gain ( dBi )	Polarization ( H/V )	Result
3760	-48.17	-13	-35.17	-67.11	-54.8	1.69	8.31	V	Pass
5639	-40.55	-13	-27.55	-63.65	-47.6	2.71	9.76	V	Pass
7520	-38.21	-13	-25.21	-67.72	-47.6	2.42	11.81	V	Pass



<High Channel>

<b>Band :</b>	GSM1900		<b>Temperature :</b>	23~24°C					
<b>Test Mode :</b>	EDGE class 8 Link (8PSK)		<b>Relative Humidity :</b>	46~48%					
<b>Test Engineer :</b>	Derreck Chen and Nick Yu		<b>Polarization :</b>	Horizontal					
<b>Remark :</b>	Spurious emissions within 30-1000MHz were found more than 20dB below limit line.								
Frequency ( MHz )	EIRP ( dBm )	Limit ( dBm )	Over Limit ( dB )	SPA Reading ( dBm )	S.G. Power ( dBm )	TX Cable loss ( dB )	TX Antenna Gain ( dBi )	Polarization ( H/V )	Result
3819	-48.62	-13	-35.62	-67.02	-55.3	1.70	8.38	H	Pass
5730	-38.77	-13	-25.77	-62.24	-45.8	2.76	9.79	H	Pass
7641	-35.20	-13	-22.20	-64.11	-44.7	2.38	11.88	H	Pass

<b>Band :</b>	GSM1900		<b>Temperature :</b>	23~24°C					
<b>Test Mode :</b>	EDGE class 8 Link (8PSK)		<b>Relative Humidity :</b>	46~48%					
<b>Test Engineer :</b>	Derreck Chen and Nick Yu		<b>Polarization :</b>	Vertical					
<b>Remark :</b>	Spurious emissions within 30-1000MHz were found more than 20dB below limit line.								
Frequency ( MHz )	EIRP ( dBm )	Limit ( dBm )	Over Limit ( dB )	SPA Reading ( dBm )	S.G. Power ( dBm )	TX Cable loss ( dB )	TX Antenna Gain ( dBi )	Polarization ( H/V )	Result
3820	-47.42	-13	-34.42	-66.48	-54.1	1.70	8.38	V	Pass
5730	-39.77	-13	-26.77	-63.32	-46.8	2.76	9.79	V	Pass
7640	-38.30	-13	-25.30	-67.13	-47.8	2.38	11.88	V	Pass



<Low Channel>

<b>Band :</b>	WCDMA Band V		<b>Temperature :</b>	23~24°C					
<b>Test Mode :</b>	RMC 12.2Kbps Link (QPSK)		<b>Relative Humidity :</b>	46~48%					
<b>Test Engineer :</b>	Derreck Chen and Nick Yu		<b>Polarization :</b>	Horizontal					
<b>Remark :</b>	Spurious emissions within 30-1000MHz were found more than 20dB below limit line.								
Frequency ( MHz )	ERP ( dBm )	Limit ( dBm )	Over Limit ( dB )	SPA Reading ( dBm )	S.G. Power ( dBm )	TX Cable loss ( dB )	TX Antenna Gain ( dBi )	Polarization ( H/V )	Result
1653	-52.86	-13	-39.86	-64.12	-54.6	0.98	4.87	H	Pass
2472	-43.92	-13	-30.92	-59.65	-45.8	1.28	5.32	H	Pass
3305	-47.85	-13	-34.85	-64.41	-51.3	1.54	7.14	H	Pass

<b>Band :</b>	WCDMA Band V		<b>Temperature :</b>	23~24°C					
<b>Test Mode :</b>	RMC 12.2Kbps Link (QPSK)		<b>Relative Humidity :</b>	46~48%					
<b>Test Engineer :</b>	Derreck Chen and Nick Yu		<b>Polarization :</b>	Vertical					
<b>Remark :</b>	Spurious emissions within 30-1000MHz were found more than 20dB below limit line.								
Frequency ( MHz )	ERP ( dBm )	Limit ( dBm )	Over Limit ( dB )	SPA Reading ( dBm )	S.G. Power ( dBm )	TX Cable loss ( dB )	TX Antenna Gain ( dBi )	Polarization ( H/V )	Result
1653	-50.86	-13	-37.86	-64.46	-52.6	0.98	4.87	V	Pass
2480	-44.69	-13	-31.69	-61.03	-46.6	1.28	5.34	V	Pass
3312	-41.62	-13	-28.62	-59.8	-45.1	1.55	7.17	V	Pass



<Middle Channel>

<b>Band :</b>	WCDMA Band V	<b>Temperature :</b>	23~24°C						
<b>Test Mode :</b>	RMC 12.2Kbps Link (QPSK)	<b>Relative Humidity :</b>	46~48%						
<b>Test Engineer :</b>	Derreck Chen and Nick Yu	<b>Polarization :</b>	Horizontal						
<b>Remark :</b>	Spurious emissions within 30-1000MHz were found more than 20dB below limit line.								
Frequency ( MHz )	ERP ( dBm )	Limit ( dBm )	Over Limit ( dB )	SPA Reading ( dBm )	S.G. Power ( dBm )	TX Cable loss ( dB )	TX Antenna Gain ( dBi )	Polarization ( H/V )	Result
1672	-53.42	-13	-40.42	-65.05	-55.1	0.99	4.82	H	Pass
2504	-39.94	-13	-26.94	-55.96	-41.9	1.29	5.40	H	Pass
3345	-50.09	-13	-37.09	-66.58	-53.7	1.56	7.32	H	Pass

<b>Band :</b>	WCDMA Band V	<b>Temperature :</b>	23~24°C						
<b>Test Mode :</b>	RMC 12.2Kbps Link (QPSK)	<b>Relative Humidity :</b>	46~48%						
<b>Test Engineer :</b>	Derreck Chen and Nick Yu	<b>Polarization :</b>	Vertical						
<b>Remark :</b>	Spurious emissions within 30-1000MHz were found more than 20dB below limit line.								
Frequency ( MHz )	ERP ( dBm )	Limit ( dBm )	Over Limit ( dB )	SPA Reading ( dBm )	S.G. Power ( dBm )	TX Cable loss ( dB )	TX Antenna Gain ( dBi )	Polarization ( H/V )	Result
1672	-50.42	-13	-37.42	-63.55	-52.1	0.99	4.82	V	Pass
2512	-45.93	-13	-32.93	-62.11	-47.9	1.29	5.41	V	Pass
3345	-47.49	-13	-34.49	-65.52	-51.1	1.56	7.32	V	Pass



<High Channel>

<b>Band :</b>	WCDMA Band V		<b>Temperature :</b>	23~24°C					
<b>Test Mode :</b>	RMC 12.2Kbps Link (QPSK)		<b>Relative Humidity :</b>	46~48%					
<b>Test Engineer :</b>	Derreck Chen and Nick Yu		<b>Polarization :</b>	Horizontal					
<b>Remark :</b>	Spurious emissions within 30-1000MHz were found more than 20dB below limit line.								
Frequency ( MHz )	ERP ( dBm )	Limit ( dBm )	Over Limit ( dB )	SPA Reading ( dBm )	S.G. Power ( dBm )	TX Cable loss ( dB )	TX Antenna Gain ( dBi )	Polarization ( H/V )	Result
1696	-52.30	-13	-39.30	-63.66	-53.9	1.00	4.75	H	Pass
2536	-42.82	-13	-29.82	-59.34	-44.8	1.30	5.43	H	Pass
3392	-45.80	-13	-32.80	-62.37	-49.6	1.57	7.52	H	Pass

<b>Band :</b>	WCDMA Band V		<b>Temperature :</b>	23~24°C					
<b>Test Mode :</b>	RMC 12.2Kbps Link (QPSK)		<b>Relative Humidity :</b>	46~48%					
<b>Test Engineer :</b>	Derreck Chen and Nick Yu		<b>Polarization :</b>	Vertical					
<b>Remark :</b>	Spurious emissions within 30-1000MHz were found more than 20dB below limit line.								
Frequency ( MHz )	ERP ( dBm )	Limit ( dBm )	Over Limit ( dB )	SPA Reading ( dBm )	S.G. Power ( dBm )	TX Cable loss ( dB )	TX Antenna Gain ( dBi )	Polarization ( H/V )	Result
1688	-48.97	-13	-35.97	-62.54	-50.6	1.00	4.77	V	Pass
2536	-44.92	-13	-31.92	-61.49	-46.9	1.30	5.43	V	Pass
3384	-38.63	-13	-25.63	-56.66	-42.4	1.57	7.49	V	Pass



<Low Channel>

<b>Band :</b>	WCDMA Band II	<b>Temperature :</b>	23~24°C						
<b>Test Mode :</b>	RMC 12.2Kbps Link (QPSK)	<b>Relative Humidity :</b>	46~48%						
<b>Test Engineer :</b>	Derreck Chen and Nick Yu	<b>Polarization :</b>	Horizontal						
<b>Remark :</b>	Spurious emissions within 30-1000MHz were found more than 20dB below limit line.								
Frequency ( MHz )	EIRP ( dBm )	Limit ( dBm )	Over Limit ( dB )	SPA Reading ( dBm )	S.G. Power ( dBm )	TX Cable loss ( dB )	TX Antenna Gain ( dBi )	Polarization ( H/V )	Result
3700	-44.13	-13	-31.13	-61.96	-50.7	1.67	8.24	H	Pass
5555	-39.53	-13	-26.53	-62.71	-46.6	2.66	9.72	H	Pass
7403	-32.25	-13	-19.25	-62.13	-41.4	2.46	11.61	H	Pass

<b>Band :</b>	WCDMA Band II	<b>Temperature :</b>	23~24°C						
<b>Test Mode :</b>	RMC 12.2Kbps Link (QPSK)	<b>Relative Humidity :</b>	46~48%						
<b>Test Engineer :</b>	Derreck Chen and Nick Yu	<b>Polarization :</b>	Vertical						
<b>Remark :</b>	Spurious emissions within 30-1000MHz were found more than 20dB below limit line.								
Frequency ( MHz )	EIRP ( dBm )	Limit ( dBm )	Over Limit ( dB )	SPA Reading ( dBm )	S.G. Power ( dBm )	TX Cable loss ( dB )	TX Antenna Gain ( dBi )	Polarization ( H/V )	Result
3707	-46.32	-13	-33.32	-65.06	-52.9	1.67	8.25	V	Pass
5555	-43.53	-13	-30.53	-66.56	-50.6	2.66	9.72	V	Pass
7403	-35.55	-13	-22.55	-64.98	-44.7	2.46	11.61	V	Pass



<Middle Channel>

<b>Band :</b>	WCDMA Band II		<b>Temperature :</b>	23~24°C					
<b>Test Mode :</b>	RMC 12.2Kbps Link (QPSK)		<b>Relative Humidity :</b>	46~48%					
<b>Test Engineer :</b>	Derreck Chen and Nick Yu		<b>Polarization :</b>	Horizontal					
<b>Remark :</b>	Spurious emissions within 30-1000MHz were found more than 20dB below limit line.								
Frequency ( MHz )	EIRP ( dBm )	Limit ( dBm )	Over Limit ( dB )	SPA Reading ( dBm )	S.G. Power ( dBm )	TX Cable loss ( dB )	TX Antenna Gain ( dBi )	Polarization ( H/V )	Result
3763	-30.57	-13	-17.57	-48.55	-37.2	1.69	8.32	H	Pass
5639	-42.35	-13	-29.35	-65.56	-49.4	2.71	9.76	H	Pass
7515	-28.72	-13	-15.72	-58.56	-38.1	2.42	11.81	H	Pass

<b>Band :</b>	WCDMA Band II		<b>Temperature :</b>	23~24°C					
<b>Test Mode :</b>	RMC 12.2Kbps Link (QPSK)		<b>Relative Humidity :</b>	46~48%					
<b>Test Engineer :</b>	Derreck Chen and Nick Yu		<b>Polarization :</b>	Vertical					
<b>Remark :</b>	Spurious emissions within 30-1000MHz were found more than 20dB below limit line.								
Frequency ( MHz )	EIRP ( dBm )	Limit ( dBm )	Over Limit ( dB )	SPA Reading ( dBm )	S.G. Power ( dBm )	TX Cable loss ( dB )	TX Antenna Gain ( dBi )	Polarization ( H/V )	Result
3756	-35.08	-13	-22.08	-54.08	-41.7	1.68	8.31	V	Pass
5639	-42.05	-13	-29.05	-65.19	-49.1	2.71	9.76	V	Pass
7515	-34.32	-13	-21.32	-64.11	-43.7	2.42	11.81	V	Pass



<High Channel>

<b>Band :</b>	WCDMA Band II		<b>Temperature :</b>	23~24°C					
<b>Test Mode :</b>	RMC 12.2Kbps Link (QPSK)		<b>Relative Humidity :</b>	46~48%					
<b>Test Engineer :</b>	Derreck Chen and Nick Yu		<b>Polarization :</b>	Horizontal					
<b>Remark :</b>	Spurious emissions within 30-1000MHz were found more than 20dB below limit line.								
Frequency ( MHz )	EIRP ( dBm )	Limit ( dBm )	Over Limit ( dB )	SPA Reading ( dBm )	S.G. Power ( dBm )	TX Cable loss ( dB )	TX Antenna Gain ( dBi )	Polarization ( H/V )	Result
3812	-30.43	-13	-17.43	-48.64	-37.1	1.70	8.37	H	Pass
5723	-42.06	-13	-29.06	-65.93	-49.1	2.75	9.79	H	Pass
7627	-33.81	-13	-20.81	-62.84	-43.3	2.39	11.88	H	Pass

<b>Band :</b>	WCDMA Band II		<b>Temperature :</b>	23~24°C					
<b>Test Mode :</b>	RMC 12.2Kbps Link (QPSK)		<b>Relative Humidity :</b>	46~48%					
<b>Test Engineer :</b>	Derreck Chen and Nick Yu		<b>Polarization :</b>	Vertical					
<b>Remark :</b>	Spurious emissions within 30-1000MHz were found more than 20dB below limit line.								
Frequency ( MHz )	EIRP ( dBm )	Limit ( dBm )	Over Limit ( dB )	SPA Reading ( dBm )	S.G. Power ( dBm )	TX Cable loss ( dB )	TX Antenna Gain ( dBi )	Polarization ( H/V )	Result
3812	-36.93	-13	-23.93	-56.12	-43.6	1.70	8.37	V	Pass
5723	-41.76	-13	-28.76	-65.26	-48.8	2.75	9.79	V	Pass
7627	-35.71	-13	-22.71	-64.56	-45.2	2.39	11.88	V	Pass

## 3.8 Frequency Stability Measurement

### 3.8.1 Description of Frequency Stability Measurement

The frequency stability shall be measured by variation of ambient temperature and variation of primary supply voltage to ensure that the fundamental emission stays within the authorized frequency block. The frequency stability of the transmitter shall be maintained within  $\pm 0.00025\%$  ( $\pm 2.5\text{ppm}$ ) of the center frequency.

### 3.8.2 Measuring Instruments

The measuring equipment is listed in the section 4 of this test report.

### 3.8.3 Test Procedures for Temperature Variation

1. The testing follows FCC KDB 971168 v02r02 Section 9.0.
2. The EUT was set up in the thermal chamber and connected with the system simulator.
3. With power OFF, the temperature was decreased to  $-30^{\circ}\text{C}$  and the EUT was stabilized before testing. Power was applied and the maximum change in frequency was recorded within one minute.
4. With power OFF, the temperature was raised in  $10^{\circ}\text{C}$  steps up to  $50^{\circ}\text{C}$ . The EUT was stabilized at each step for at least half an hour. Power was applied and the maximum frequency change was recorded within one minute.

### 3.8.4 Test Procedures for Voltage Variation

1. The testing follows FCC KDB 971168 v02r02 Section 9.0.
2. The EUT was placed in a temperature chamber at  $25\pm 5^{\circ}\text{C}$  and connected with the system simulator.
3. The power supply voltage to the EUT was varied from BEP to 115% of the nominal value measured at the input to the EUT.
4. The variation in frequency was measured for the worst case.

### 3.8.5 Test Setup

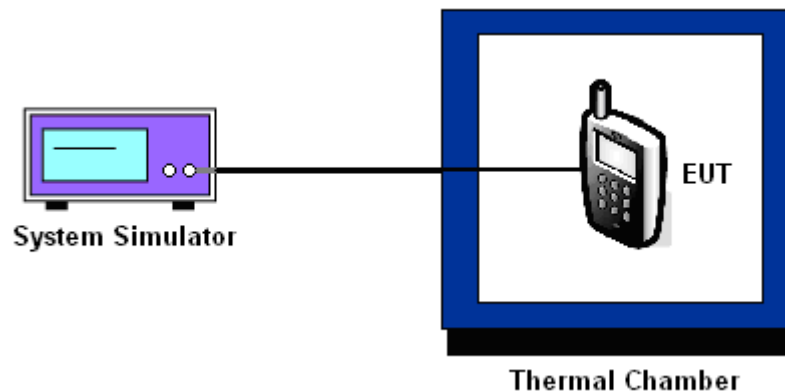



3.8.6 Test Result of Temperature Variation

Band :	GSM 850	Channel :	189
Limit (ppm) :	2.5	Frequency :	836.4 MHz

Temperature (°C)	GPRS class 8	EDGE class 8	Result
	Deviation (ppm)	Deviation (ppm)	
50	0.0717	0.0036	PASS
40	0.0036	0.0478	
30	0.0705	0.0442	
20(Ref.)	0.0000	0.0000	
10	0.0670	0.0024	
0	0.0765	0.0048	
-10	0.0012	0.0466	
-20	0.0693	0.0418	
-30	0.0729	0.0012	



<b>Band :</b>	GSM 1900	<b>Channel :</b>	661
<b>Limit (ppm) :</b>	within authorized band	<b>Frequency :</b>	1880.0 MHz

Temperature (°C)	GSM	EDGE class 8	Result
	Deviation (ppm)	Deviation (ppm)	
50	0.0027	0.0021	PASS
40	0.0037	0.0032	
30	0.0032	0.0011	
20(Ref.)	0.0000	0.0000	
10	0.0021	0.0027	
0	0.0016	0.0005	
-10	0.0048	0.0000	
-20	0.0037	0.0021	
-30	0.0064	0.0011	

**Note:** The frequency fundamental emissions stay within the authorized frequency block based on the frequency deviation measured is small.

<b>Band :</b>	WCDMA Band V	<b>Channel :</b>	4182
<b>Limit (ppm) :</b>	2.5	<b>Frequency :</b>	836.4 MHz

Temperature (°C)	RMC 12.2Kbps	Result
	Deviation (ppm)	
50	0.0012	PASS
40	0.0036	
30	0.0108	
20(Ref.)	0.0000	
10	0.0084	
0	0.0084	
-10	0.0096	
-20	0.0012	
-30	0.0072	



Band :	WCDMA Band II	Channel :	9400
Limit (ppm) :	within authorized band	Frequency :	1880.0 MHz

Temperature (°C)	RMC 12.2Kbps	Result
	Deviation (ppm)	
50	0.0080	PASS
40	0.0069	
30	0.0005	
20(Ref.)	0.0000	
10	0.0069	
0	0.0011	
-10	0.0059	
-20	0.0080	
-30	0.0016	

**Note:** The frequency fundamental emissions stay within the authorized frequency block based on the frequency deviation measured is small.



3.8.7 Test Result of Voltage Variation

Band & Channel	Mode	Voltage (Volt)	Deviation (ppm)	Limit (ppm)	Result
GSM 850 CH189	GPRS class 8	4.2	0.0777	2.5	PASS
		3.8	0.0729		
		BEP	0.0753		
	EDGE class 8	4.2	0.0048		
		3.8	0.0036		
		BEP	0.0000		
GSM 1900 CH661	GSM	4.2	0.0032	(Note 3.)	
		3.8	0.0021		
		BEP	0.0037		
	EDGE class 8	4.2	0.0005		
		3.8	0.0005		
		BEP	0.0011		
WCDMA Band V CH4182	RMC 12.2Kbps	4.2	0.0000	2.5	
		3.8	0.0012		
		BEP	0.0108		
WCDMA Band II CH9400	RMC 12.2Kbps	4.2	0.0016	(Note 3.)	
		3.8	0.0005		
		BEP	0.0005		

Note:

1. Normal Voltage = 3.8V.
2. Battery End Point (BEP) = 3.4 V.
3. The frequency fundamental emissions stay within the authorized frequency block based on the frequency deviation measured is small.



## 4 List of Measuring Equipment

Instrument	Manufacturer	Model No.	Serial No.	Characteristics	Calibration Date	Test Date	Due Date	Remark
System Simulator	Rohde & Schwarz	CMU200	117995	N/A	Jul. 29, 2014	Oct. 17, 2014	Jul. 28, 2015	Conducted (TH02-HY)
Spectrum Analyzer	Rohde & Schwarz	FSP40	100055	9kHz~40GHz	Jun. 09, 2014	Oct. 17, 2014	Jun. 08, 2015	Conducted (TH02-HY)
Thermal Chamber	Ten Billion	TTH-D3SP	TBN-930701	N/A	Jul. 17, 2014	Oct. 17, 2014	Jul. 16, 2015	Conducted (TH02-HY)
Spectrum Analyzer	Rohde & Schwarz	FSV30	101749	10Hz ~ 30GHz	Feb. 10, 2014	Oct. 17, 2014 ~ Oct. 18, 2014	Feb. 09, 2015	Radiation (03CH07-HY)
Bilog Antenna	Schaffner	CBL6111C	2726	30MHz ~ 1GHz	Sep. 27, 2014	Oct. 17, 2014 ~ Oct. 18, 2014	Sep. 26, 2015	Radiation (03CH07-HY)
Double Ridge Horn Antenna	ESCO	3117	75962	1GHz~18GHz	Aug. 19, 2014	Oct. 17, 2014 ~ Oct. 18, 2014	Aug. 18, 2015	Radiation (03CH07-HY)
Preamplifier	COM-POWER	PA-103A	161241	10 MHz ~ 1000MHz	Mar. 17, 2014	Oct. 17, 2014 ~ Oct. 18, 2014	Mar. 16, 2015	Radiation (03CH07-HY)
Preamplifier	Agilent	8449B	3008A02362	1 GHz~26.5 GHz	Nov. 29, 2013	Oct. 17, 2014 ~ Oct. 18, 2014	Nov. 28, 2014	Radiation (03CH07-HY)
Turn Table	ChainTek	ChainTek 3000	N/A	0 ~ 360 degree	N/A	Oct. 17, 2014 ~ Oct. 18, 2014	N/A	Radiation (03CH07-HY)
Antenna Mast	ChainTek	M-400-0	114/8000604/	N/A	N/A	Oct. 17, 2014 ~ Oct. 18, 2014	N/A	Radiation (03CH07-HY)
Signal Generator	Rohde & Schwarz	SMF100A	101107	100kHz~40GHz	May 23, 2014	Oct. 17, 2014 ~ Oct. 18, 2014	May 22, 2015	Radiation (03CH07-HY)
Double Ridge Horn Antenna	ESCO	3117	00066583	1GHz~18GHz	Jul. 24, 2014	Oct. 17, 2014 ~ Oct. 18, 2014	Jul. 23, 2015	Radiation (03CH07-HY)



## 5 Uncertainty of Evaluation

### Uncertainty of Radiated Emission Measurement (30 MHz ~ 1000 MHz)

Measuring Uncertainty for a Level of Confidence of 95% ( $U = 2Uc(y)$ )	4.50
---	------