



# FCC RF Test Report

**APPLICANT** : Motorola Mobility, LLC  
**EQUIPMENT** : Mobile Cellular Phone  
**BRAND NAME** : Motorola  
**MODEL NAME** : 4054  
**FCC ID** : IHDT56QD1  
**STANDARD** : FCC 47 CFR Part 2, and 90(S)  
**CLASSIFICATION** : PCS Licensed Transmitter Held to Ear (PCE)

The product was received on Aug. 06, 2014 and testing was completed on Sep. 03, 2014. We, SPORTON INTERNATIONAL INC., would like to declare that the tested sample has been evaluated in accordance with the procedures given in ANSI / TIA / EIA-603-C-2004 and shown compliance with the applicable technical standards.

The test results in this report apply exclusively to the tested model / sample. Without written approval of SPORTON INTERNATIONAL INC., the test report shall not be reproduced except in full.

Reviewed by: Joseph Lin / Supervisor

Approved by: Jones Tsai / Manager



## **SPORTON INTERNATIONAL INC.**

**No. 52, Hwa Ya 1<sup>st</sup> Rd., Hwa Ya Technology Park, Kwei-Shan Hsiang, Tao Yuan Hsien, Taiwan, R.O.C.**

**SPORTON INTERNATIOINAL INC.**

TEL : 886-3-327-3456

FAX : 886-3-328-4978

FCC ID : IHDT56QD1

Page Number : 1 of 46

Report Issued Date : Sep. 30, 2014

Report Version : Rev. 01

Report Template No.: BU5-FWCDMA Version 1.0



# TABLE OF CONTENTS

**REVISION HISTORY..... 3**

**SUMMARY OF TEST RESULT ..... 4**

**1 GENERAL DESCRIPTION ..... 5**

    1.1 Applicant..... 5

    1.2 Manufacturer ..... 5

    1.3 Feature of Equipment Under Test..... 5

    1.4 Product Specification of Equipment Under Test ..... 6

    1.5 Modification of EUT ..... 6

    1.6 Maximum Conducted Power, Frequency Tolerance, and Emission Designator..... 6

    1.7 Testing Site..... 7

    1.8 Applied Standards ..... 7

**2 TEST CONFIGURATION OF EQUIPMENT UNDER TEST ..... 8**

    2.1 Test Mode..... 8

    2.2 Connection Diagram of Test System ..... 9

    2.3 Support Unit used in test configuration ..... 10

    2.4 Measurement Results Explanation Example ..... 10

**3 TEST RESULT ..... 11**

    3.1 Conducted Output Power Measurement..... 11

    3.2 Bandwidth Limitations Measurement ..... 13

    3.3 Emissions Mask Measurement ..... 21

    3.4 Emissions Mask – Out Of Band Emissions Measurement..... 26

    3.5 Field Strength of Spurious Radiation Measurement ..... 31

    3.6 Frequency Stability Measurement..... 42

**4 LIST OF MEASURING EQUIPMENT ..... 45**

**5 UNCERTAINTY OF EVALUATION ..... 46**



### REVISION HISTORY

REPORT NO.	VERSION	DESCRIPTION	ISSUED DATE
FW480670A	Rev. 01	Initial issue of report	Sep. 30, 2014



### SUMMARY OF TEST RESULT

Report Section	FCC Rule	Description	Limit	Result	Remark
3.1	§2.1046 §90.635	Conducted Output Power	< 100 Watts	PASS	-
3.2	§2.1049 §90.209	Bandwidth limitations	N/A (Reporting only)	PASS	-
3.3	§2.1051 §90.691	Emission masks – In-band emissions	< 50+10log <sub>10</sub> (P[Watts])	PASS	-
3.4	§2.1051 §90.691	Emission masks – Out of band emissions	< 43+10log <sub>10</sub> (P[Watts])	PASS	-
3.5	§2.1053 §90.691	Field Strength of Spurious Radiation	< 43+10log <sub>10</sub> (P[Watts])	PASS	Under limit 36.51 dB at 3292.000 MHz
3.6	§2.1055 §90.213	Frequency Stability for Temperature & Voltage	< 2.5 ppm	PASS	-



# 1 General Description

## 1.1 Applicant

Motorola Mobility, LLC

222 W Merchandise Mart Plaza, Suite 1800, Chicago, IL 60654, United States

## 1.2 Manufacturer

Motorola Mobility, LLC

222 W Merchandise Mart Plaza, Suite 1800, Chicago, IL 60654, United States

## 1.3 Feature of Equipment Under Test

Product Feature & Specification	
Equipment	Mobile Cellular Phone
Brand Name	Motorola
Model Name	4054
FCC ID	IHDT56QD1
IMEI Code	990005300005858
EUT supports Radios application	CDMA/EV-DO/GSM/EGPRS/WCDMA/HSPA/LTE/NFC 2.4GHz WLAN 11b/g/n HT20 WLAN 11ac VHT20 5GHz WLAN 11a/n HT20/HT40 WLAN 11ac VHT20/VHT40/VHT80 Bluetooth v3.0 EDR Bluetooth v4.0 - LE
HW Version	P2
EUT Stage	Identical Prototype

Remark: The above EUT's information was declared by manufacturer. Please refer to the specifications or user's manual for more detailed description.

Accessory List	
AC Adapter	Brand Name : Motorola
	Model Name : SPN5864A
Earphone	Brand Name : Motorola
	Model Name : SJYN1305A
USB Cable	Brand Name : Motorola
	Model Name : SKN6448A
Battery	Brand Name : LG
	Model Name : EZ30



### 1.4 Product Specification of Equipment Under Test

Product Specification subjective to this standard	
Tx Frequency	817.9 MHz ~ 823.1 MHz
Rx Frequency	862.9 MHz ~ 868.1 MHz
Maximum Output Power to Antenna	23.84 dBm
Antenna Type	Fixed Internal Antenna
Type of Modulation	CDMA2000 : QPSK CDMA2000 1xEV-DO : QPSK/8PSK

**Remark:** This test report recorded only product characteristics and test results of PCS Licensed Transmitter Held to Ear (PCE).

### 1.5 Modification of EUT

No modifications are made to the EUT during all test items.

### 1.6 Maximum Conducted Power, Frequency Tolerance, and Emission Designator

FCC Rule	System	Type of Modulation	Maximum Conducted Power (W)	Frequency Tolerance (ppm)	Emission Designator
Part 90(S)	CDMA2000 BC10 1xEV-DO Rev. 0	QPSK	0.2421	0.0390 ppm	1M28F9W
Part 90(S)	CDMA2000 BC10 1xRTT	QPSK	0.2404	0.0475 ppm	1M28F9W



### 1.7 Testing Site

Sporton Lab is accredited to ISO 17025 by Taiwan Accreditation Foundation (TAF code : 1190) and the FCC designation No. TW1022 under the FCC 2.948(e) by Mutual Recognition Agreement (MRA) in FCC Test.

<b>Test Site</b>	SPORTON INTERNATIONAL INC.	
<b>Test Site Location</b>	No. 52, Hwa Ya 1 <sup>st</sup> Rd., Hwa Ya Technology Park, Kwei-Shan Hsiang, Tao Yuan Hsien, Taiwan, R.O.C. TEL: +886-3-327-3456 FAX: +886-3-328-4978	
<b>Test Site No.</b>	<b>Sporton Site No.</b>	
	TH02-HY	03CH07-HY

### 1.8 Applied Standards

According to the specifications of the manufacturer, the EUT must comply with the requirements of the following standards:

- ♦ FCC 47 CFR Part 2, 90
- ♦ ANSI / TIA / EIA-603-C-2004
- ♦ FCC KDB 971168 D01 Power Meas. License Digital Systems v02r01
- ♦ KDB 648474 D03 Handset Wireless Chargers Battery Covers v01r02

**Remark:**

1. All test items were verified and recorded according to the standards and without any deviation during the test.
2. This EUT has also been tested and complied with the requirements of FCC Part 15, Subpart B, recorded in a separate test report.



## 2 Test Configuration of Equipment Under Test

### 2.1 Test Mode

Antenna port conducted and radiated test items were performed according to KDB 971168 D01 Power Meas. License Digital Systems v02r01 with maximum output power.

Radiated measurements were performed with rotating EUT in different three orthogonal test planes to find the maximum emission.

Frequency range investigated for radiated emission is 30 MHz to 9000 MHz for CDMA2000 BC10.

All modes and data rates and positions were investigated, and the wireless charger configuration was evaluated.

Test Modes		
Band	Radiated TCs	Conducted TCs
CDMA2000 BC10	<ul style="list-style-type: none"> <li>■ 1xRTT Link</li> <li>■ 1xEV-DO Rev. 0 Link</li> <li>■ 1xRTT Link with WPC Charging</li> </ul>	<ul style="list-style-type: none"> <li>■ 1xRTT Link</li> <li>■ 1xEV-DO Rev. 0 Link</li> </ul>

The conducted power table is as follows:

Conducted Power (*Unit: dBm)			
Band	CDMA2000 BC10		
Channel	476	580	676
Frequency	817.90	820.50	822.90
1xRTT RC1 SO55	23.81	23.80	23.74
1xRTT RC3 SO55	23.79	23.78	23.73
1xRTT RC3 SO32 (+ F-SCH)	23.78	23.80	23.72
1xRTT RC3 SO32 (+SCH)	23.77	23.79	23.73
1xEV-DO RTAP 153.6kbps	23.84	23.82	23.75
1xEV-DO RETAP 4096Bits	23.83	23.80	23.76

## 2.2 Connection Diagram of Test System

### <EUT with Adapter Mode>

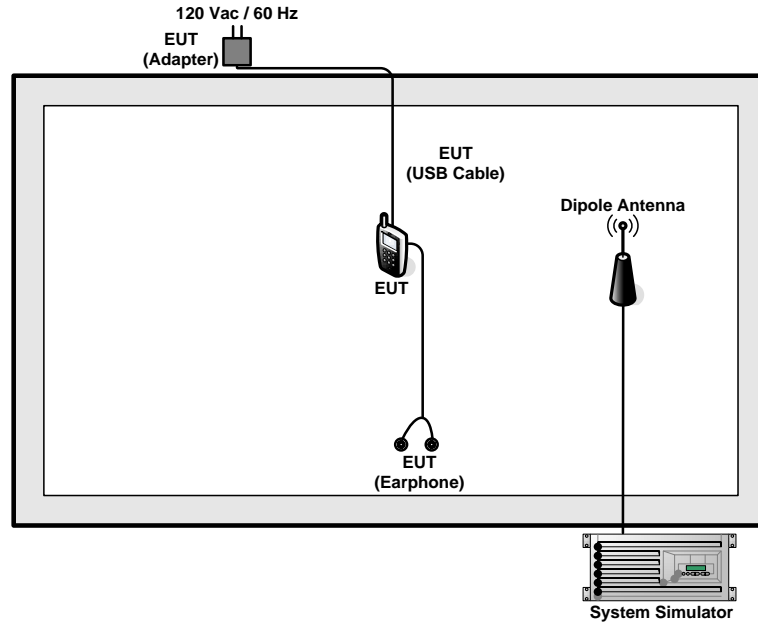

### <EUT with CHARGER PAD Mode>

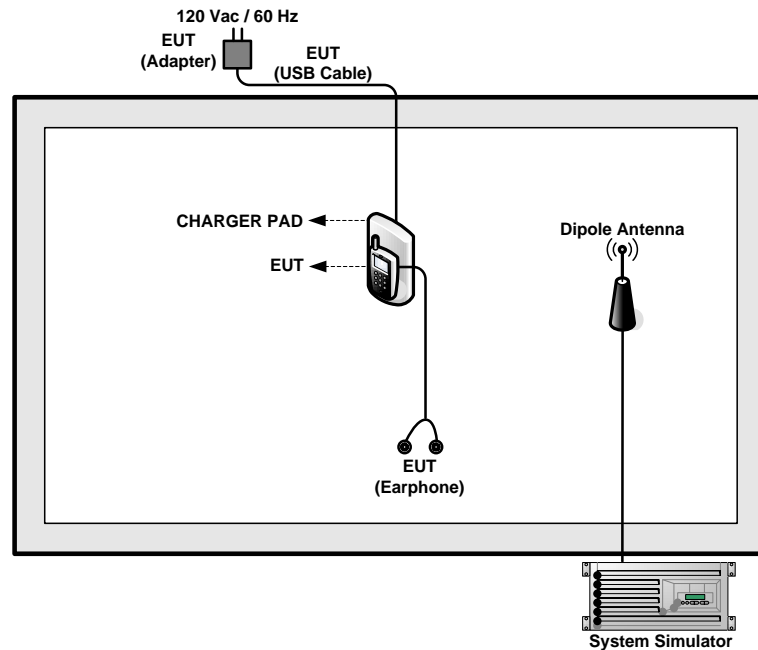



### 2.3 Support Unit used in test configuration

Item	Equipment	Trade Name	Model No.	FCC ID	Data Cable	Power Cord
1.	System Simulator	R&S	CMU 200	N/A	N/A	Unshielded, 1.8 m
2.	CHARGER PAD	SAMSUNG	E9-91001EWE	A3LEPP100IJWU	N/A	N/A

### 2.4 Measurement Results Explanation Example

For all conducted test items:

The offset level is set in the spectrum analyzer to compensate the RF cable loss and attenuator factor between RF conducted output port and spectrum analyzer. With the offset compensation, the spectrum analyzer reading level will be exactly the RF output level.

The spectrum analyzer offset is derived from RF cable loss and attenuator factor.

*Offset = RF cable loss + attenuator factor.*

The following shows an offset computation example with RF cable loss 4.2 dB and a 10dB attenuator.

Example :

$$\begin{aligned} \text{Offset(dB)} &= \text{RF cable loss(dB)} + \text{attenuator factor(dB)}. \\ &= 4.2 + 10 = 14.2 \text{ (dB)} \end{aligned}$$

### **3 Test Result**

#### **3.1 Conducted Output Power Measurement**

##### **3.1.1 Description of the Conducted Output Power Measurement**

A system simulator was used to establish communication with the EUT. Its parameters were set to enforce EUT transmitting at the maximum power. The measured power in the radio frequency on the transmitter output terminals shall be reported.

##### **3.1.2 Measuring Instruments**

The measuring equipment is listed in the section 4 of this test report.

##### **3.1.3 Test Procedures**

1. The transmitter output port was connected to the system simulator.
2. Set EUT at maximum power through system simulator.
3. Select lowest, middle, and highest channels for each band and different modulation.
4. Measure the maximum burst average power for GSM and maximum average power for other modulation signal.

##### **3.1.4 Test Setup**

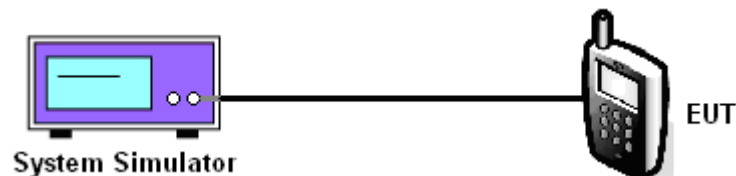



3.1.5 Test Result of Conducted Output Power

CDMA 2000 BC10			
Modes	CDMA 2000 1xRTT		
Test Status	RC1+SO55		
Channel	476 (Low)	580 (Mid)	676 (High)
Frequency (MHz)	817.9	820.5	822.9
Conducted Power (dBm)	23.81	23.80	23.74

CDMA 2000 BC10			
Modes	CDMA 2000 1xEV-DO Rev. 0		
Test Status	RTAP 153.6K		
Channel	476 (Low)	580 (Mid)	676 (High)
Frequency (MHz)	817.9	820.5	822.9
Conducted Power (dBm)	23.84	23.82	23.75

Note: maximum average power for CDMA2000.

## 3.2 Bandwidth Limitations Measurement

### 3.2.1 Description of (Occupied) Bandwidth Limitations Measurement

The 99% occupied bandwidth is the width of a frequency band such that, below the lower and above the upper frequency limits, the mean powers emitted are each equal to a specified percentage 0.5% of the total mean transmitted power.

The emission bandwidth is defined as the width of the signal between two points, located at the 2 sides of the carrier frequency, outside of which all emissions are attenuated at least 26 dB below the transmitter power.

### 3.2.2 Measuring Instruments

The measuring equipment is listed in the section 4 of this test report.

### 3.2.3 Test Procedures

1. The EUT was connected to the spectrum analyzer and system simulator via a power divider.
2. The RF output of the EUT was connected to the spectrum analyzer by RF cable and attenuator. The path loss was compensated to the results for each measurement.
3. The 99% occupied bandwidth were measured, set RBW= 1% of span, VBW $\geq$  3\*RBW, sample detector, trace maximum hold.
4. The 26dB bandwidth were measured, set RBW= 1% of EBW, VBW $\geq$  3\*RBW, peak detector, trace maximum hold.

### 3.2.4 Test Setup

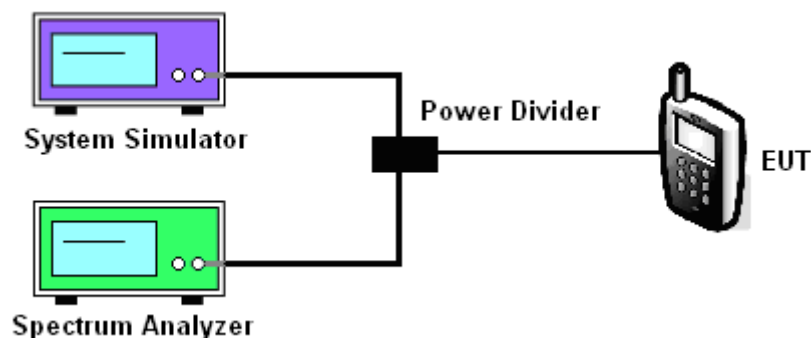



3.2.5 Test Result of Occupied Bandwidth and 26dB Bandwidth

CDMA2000 BC10			
Test Mode	CDMA 2000 1xRTT		
Test Status	RC1+SO55		
Channel	476 (Low)	580 (Mid)	676 (High)
Frequency (MHz)	817.9	820.5	822.9
99% OBW (MHz)	1.28	1.28	1.28
26dB BW (MHz)	1.43	1.43	1.43

CDMA2000 BC10			
Test Mode	CDMA 2000 1xEV-DO Rev. 0		
Test Status	RTAP 153.6K		
Channel	476 (Low)	580 (Mid)	676 (High)
Frequency (MHz)	817.9	820.5	822.9
99% OBW (MHz)	1.28	1.28	1.28
26dB BW (MHz)	1.43	1.43	1.43



### 3.2.6 Test Result (Plots) of Occupied Bandwidth and 26dB Bandwidth

Band :	CDMA2000 BC 10	Test Mode :	1xRTT RC1 SO55
--------	----------------	-------------	----------------

#### 99% Occupied Bandwidth Plot on Channel 476 (817.9 MHz)

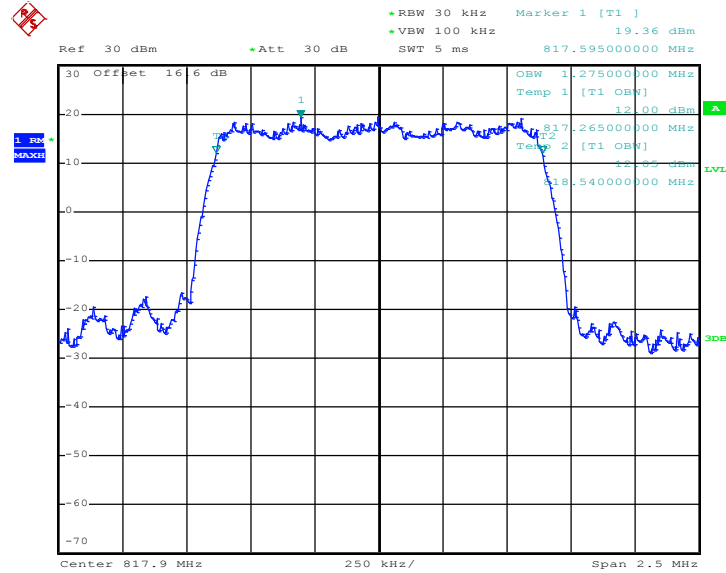

Date: 3.SEP.2014 10:46:45

#### 26dB Bandwidth Plot on Channel 476 (817.9 MHz)

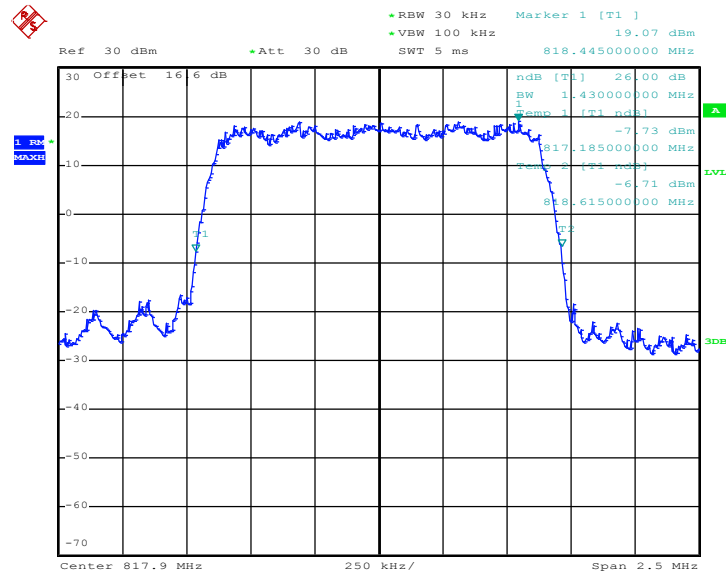

Date: 3.SEP.2014 10:42:36



99% Occupied Bandwidth Plot on Channel 580 (820.5 MHz)

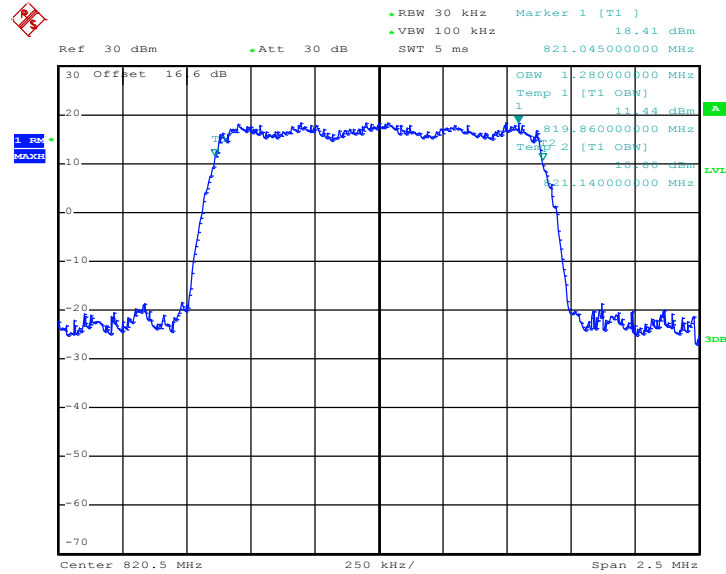

Date: 3.SEP.2014 10:46:03

26dB Bandwidth Plot on Channel 580 (820.5 MHz)

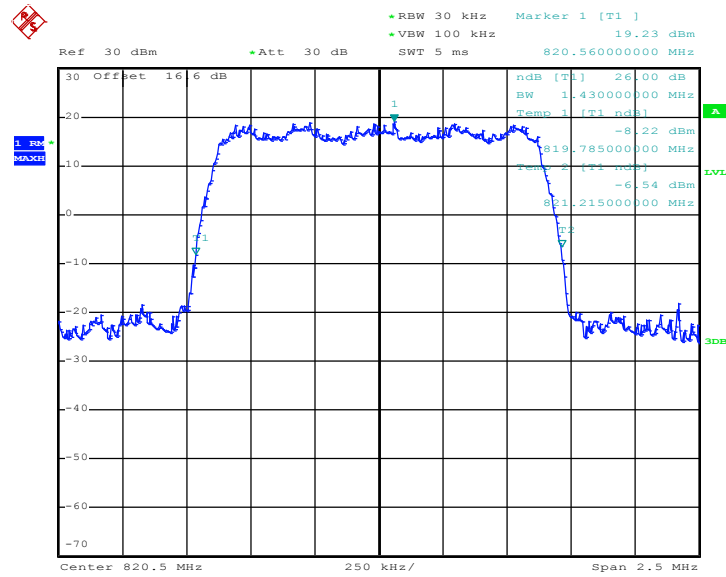

Date: 3.SEP.2014 10:43:27



99% Occupied Bandwidth Plot on Channel 676 (822.9 MHz)

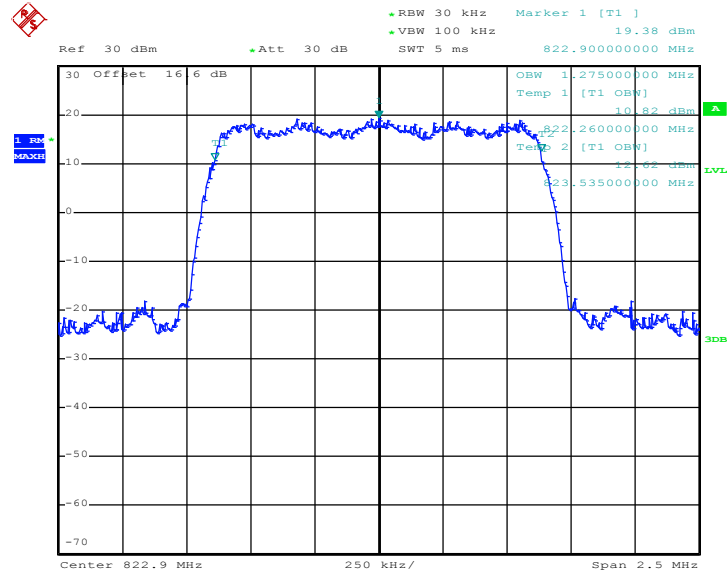

Date: 3.SEP.2014 10:45:02

26dB Bandwidth Plot on Channel 676 (822.9 MHz)

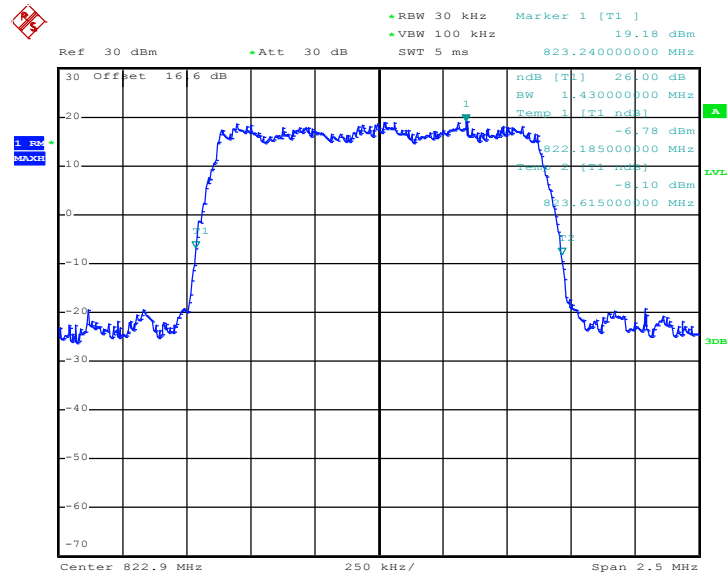

Date: 3.SEP.2014 10:44:12



Band :	CDMA2000 BC 10	Test Mode :	1xEV-DO Rev. 0
--------	----------------	-------------	----------------

99% Occupied Bandwidth Plot on Channel 476 (817.9 MHz)

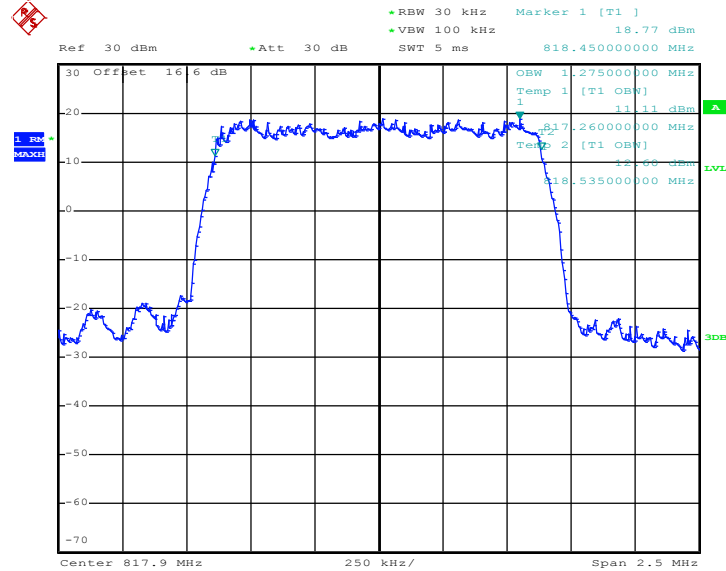

Date: 3.SEP.2014 10:07:01

26dB Bandwidth Plot on Channel 476 (817.9 MHz)

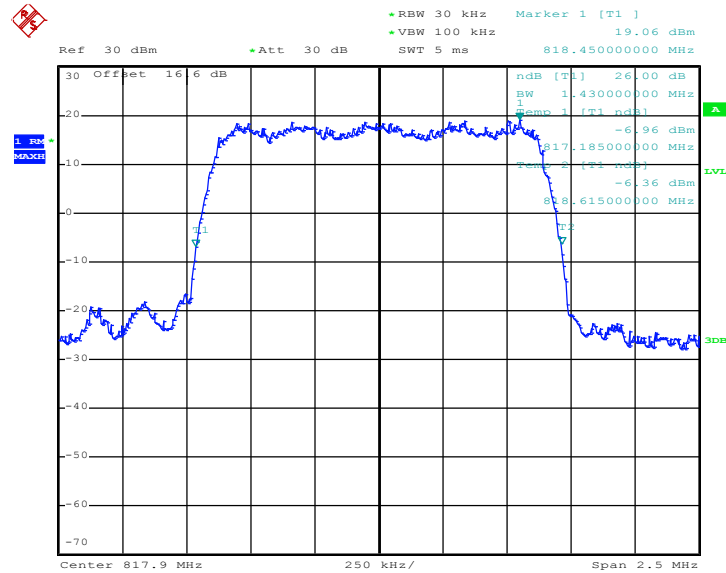

Date: 3.SEP.2014 10:01:23



### 99% Occupied Bandwidth Plot on Channel 580 (820.5 MHz)

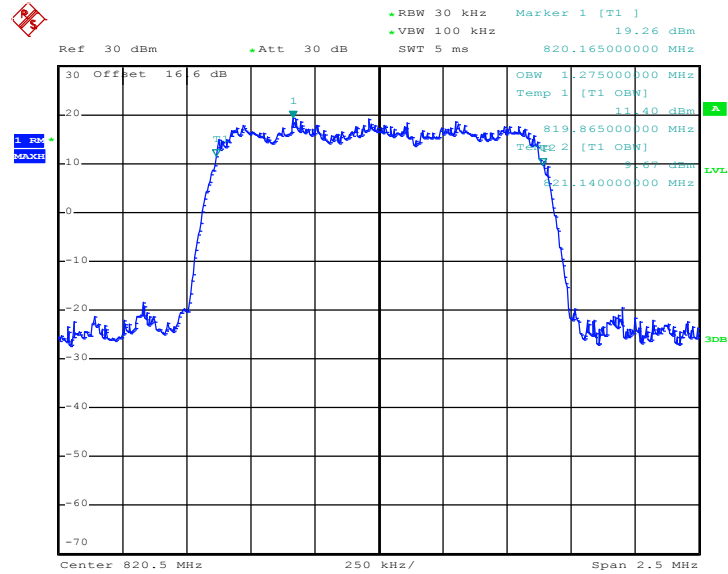

Date: 3.SEP.2014 10:06:20

### 26dB Bandwidth Plot on Channel 580 (820.5 MHz)

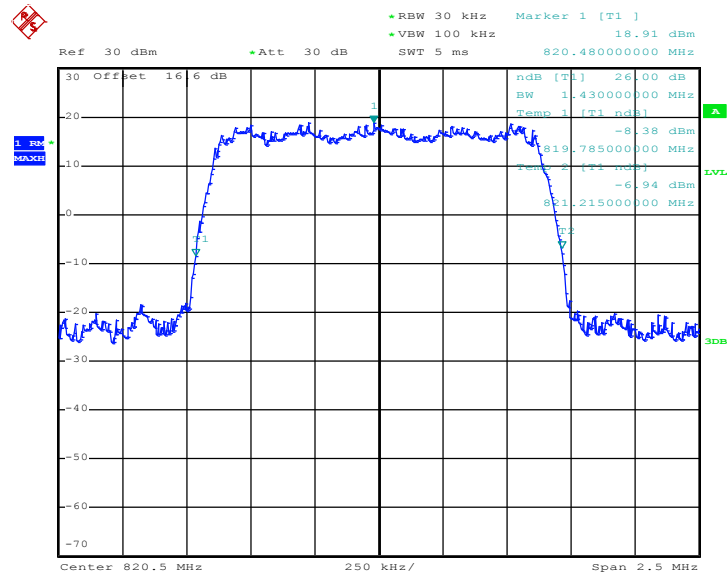

Date: 3.SEP.2014 10:02:09



### 99% Occupied Bandwidth Plot on Channel 676 (822.9 MHz)

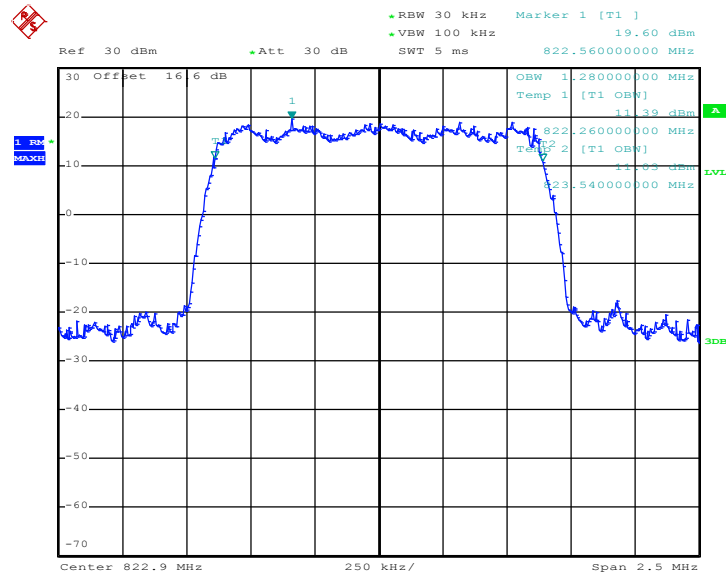

Date: 3.SEP.2014 10:05:32

### 26dB Bandwidth Plot on Channel 676 (822.9 MHz)

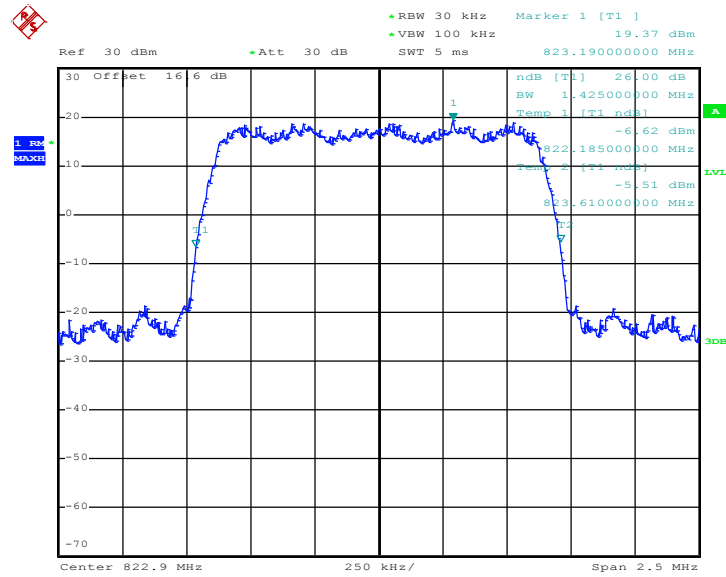

Date: 3.SEP.2014 10:02:51

### 3.3 Emissions Mask Measurement

#### 3.3.1 Description of Emissions Mask Measurement

Equipment used in this licensed to EA or non-EA systems shall comply with the emission mask provisions of FCC Part 90.691.(a)(1)

(a). Out-of-band emission requirement shall apply only to the “outer” channels included in an EA license and to spectrum adjacent to interior channels used by incumbent licensees. The emission limits are as follows:

- (1) For any frequency removed from the EA licensee's frequency block by up to and including 37.5 kHz, the power of any emission shall be attenuated below the transmitter power (P) in watts by at least  $116 \text{ Log}_{10}(f/6.1)$  decibels or  $50 + 10 \text{ Log}_{10}(P)$  decibels or 80 decibels, whichever is the lesser attenuation, where f is the frequency removed from the center of the outer channel in the block in kilohertz and where f is greater than 12.5 kHz.

#### 3.3.2 Measuring Instruments

The measuring equipment is listed in the section 4 of this test report.

#### 3.3.3 Test Procedures

1. The EUT was connected to spectrum analyzer and system simulator via power divider.
2. The emissions mask of low and high channels for the highest RF powers were measured.
3. The measured RBW and the VBW set 3 times of RBW are then set in spectrum analyzer, and the RBW correction factor  $10 \log (1\% \text{ of OBW}/\text{measured RBW})(\text{dB})$  was compensated, if required.
4. The test results were shown below plots with a correction offset factor including cable loss, insertion loss of power divider.

#### 3.3.4 Test Setup

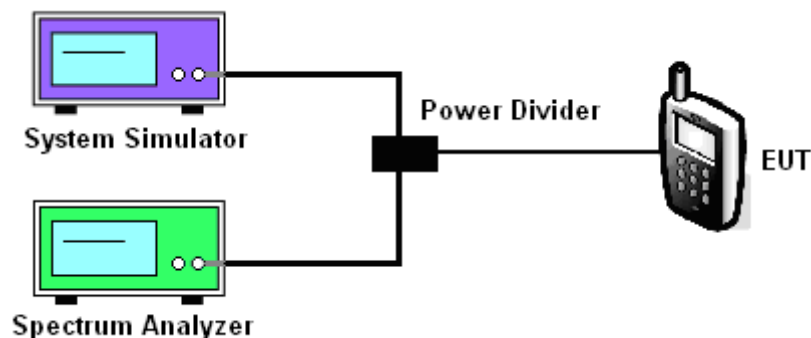



### 3.3.5 Test Result (Plots) of Conducted Emissions Mask

Band :	CDMA2000 BC 10	Test Mode :	1xRTT RC1 SO55
--------	----------------	-------------	----------------

Lower Band Edge Plot on Channel 476 (817.9 MHz)

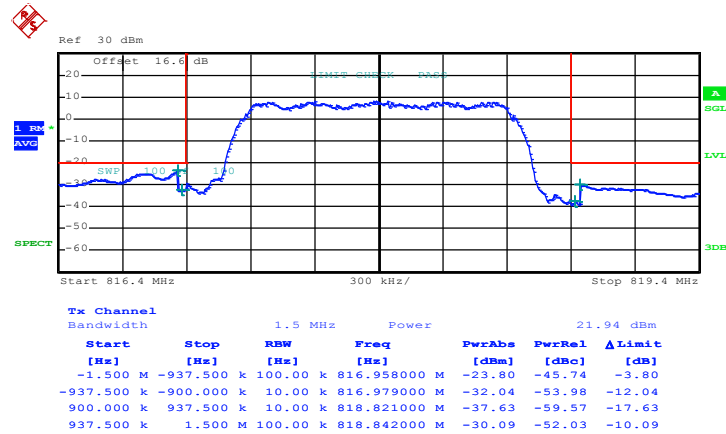

Date: 2.SEP.2014 18:23:20

Remark:

$$\begin{aligned} \text{Test Result(dBm)} &= \text{PwrAbs(dBm)} + (1\% \text{ of OBW/measured RBW}) \text{ (dB)} \\ &= \text{PwrAbs(dBm)} + 10 \cdot \text{LOG}(13\text{kHz}/10\text{KHz}) \text{ (dB)} \\ &= \text{PwrAbs(dBm)} + 1.14 \text{ (dB)} \end{aligned}$$

<1> Test result of 816.979MHz: - 32.04(dBm) + 1.14(dB)= -30.90 (dBm)

<2> Test result of 818.821MHz: - 37.63(dBm) + 1.14(dB)= -36.49 (dBm)



Higher Band Edge Plot on Channel 676 (822.9 MHz)

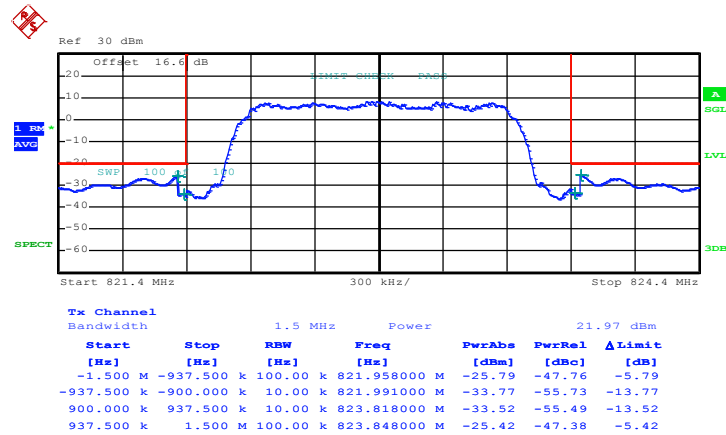

Date: 2.SEP.2014 18:33:50

Remark:

$$\begin{aligned} \text{Test Result(dBm)} &= \text{PwrAbs(dBm)} + (1\% \text{ of OBW/measured RBW}) \text{ (dB)} \\ &= \text{PwrAbs(dBm)} + 10 \cdot \text{LOG}(13\text{kHz}/10\text{kHz}) \text{ (dB)} \\ &= \text{PwrAbs(dBm)} + 1.14 \text{ (dB)} \end{aligned}$$

<1> Test result of 821.991MHz: - 33.77(dBm) + 1.14(dB)= -32.63 (dBm)

<2> Test result of 823.818MHz: - 33.52(dBm) + 1.14(dB)= -32.38 (dBm)



Band :	CDMA2000 BC 10	Test Mode :	1xEV-DO Rev. 0
--------	----------------	-------------	----------------

Lower Band Edge Plot on Channel 476 (817.9 MHz)

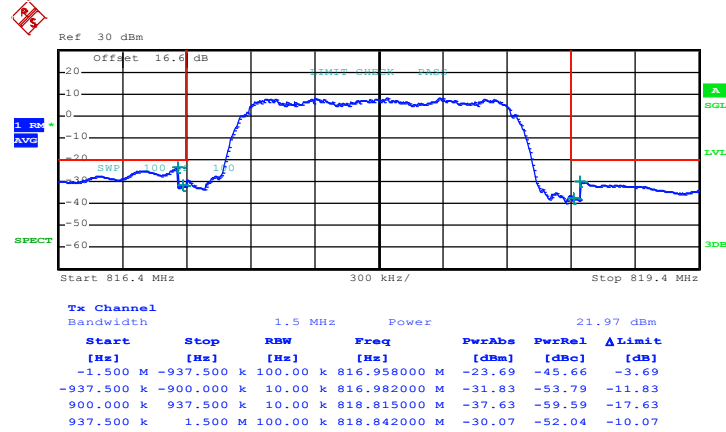

Date: 2.SEP.2014 18:18:19

Remark:

$$\begin{aligned} \text{Test Result(dBm)} &= \text{PwrAbs(dBm)} + (1\% \text{ of OBW/measured RBW}) \text{ (dB)} \\ &= \text{PwrAbs(dBm)} + 10 * \text{LOG}(13\text{kHz}/10\text{KHz}) \text{ (dB)} \\ &= \text{PwrAbs(dBm)} + 1.14 \text{ (dB)} \end{aligned}$$

<1> Test result of 816.982MHz: - 31.83(dBm) + 1.14(dB)= -30.69 (dBm)

<2> Test result of 818.815MHz: - 37.63(dBm) + 1.14(dB)= -36.49 (dBm)



Higher Band Edge Plot on Channel 676 (822.9 MHz)

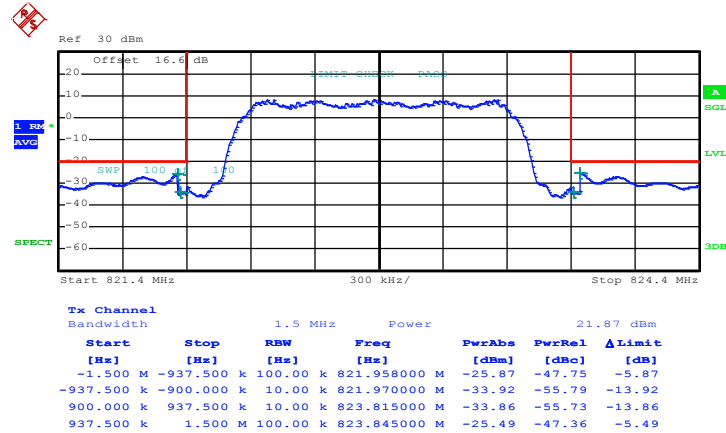

Date: 2.SEP.2014 18:34:12

Remark:

$$\begin{aligned} \text{Test Result(dBm)} &= \text{PwrAbs(dBm)} + (1\% \text{ of OBW/measured RBW}) \text{ (dB)} \\ &= \text{PwrAbs(dBm)} + 10 \cdot \text{LOG}(13\text{kHz}/10\text{kHz}) \text{ (dB)} \\ &= \text{PwrAbs(dBm)} + 1.14 \text{ (dB)} \end{aligned}$$

<1> Test result of 821.970MHz: - 33.92(dBm) + 1.14(dB)= -32.78 (dBm)

<2> Test result of 823.815MHz: - 33.86(dBm) + 1.14(dB)= -32.72 (dBm)

### 3.4 Emissions Mask – Out Of Band Emissions Measurement

#### 3.4.1 Description of Conducted Spurious Emissions Out of band emissions measurement

The power of any emission FCC Part 90.691 (a)(2) on any frequency removed from the assigned frequency by more than 250 percent of the authorized bandwidth at least  $43 + 10 \log (P)$  dB.

It is measured by means of a calibrated spectrum analyzer and scanned from 30 MHz up to a frequency including its 10th harmonic.

#### 3.4.2 Measuring Instruments

The measuring equipment is listed in the section 4 of this test report.

#### 3.4.3 Test Procedures

1. The EUT was connected to the spectrum analyzer and system simulator via a power divider.
2. The RF output of EUT was connected to the spectrum analyzer by an RF cable and attenuator. The path loss was compensated to the results for each measurement.
3. The middle channel for the highest RF power within the transmitting frequency was measured.
4. The conducted spurious emission for the whole frequency range was taken.
5. The RF fundamental frequency should be excluded against the limit line in the operating frequency band.
6. The limit line is derived from  $43 + 10\log(P)$  dB below the transmitter power P(Watts)
  - =  $P(W) - [43 + 10\log(P)]$  (dB)
  - =  $[30 + 10\log(P)]$  (dBm) -  $[43 + 10\log(P)]$  (dB)
  - = -13dBm.

#### 3.4.4 Test Setup

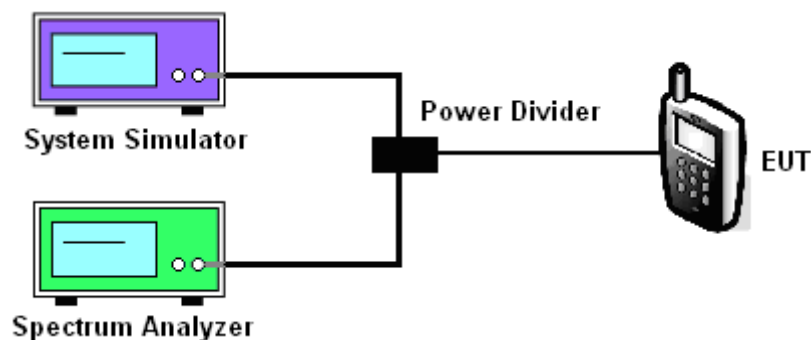



### 3.4.5 Test Result (Plots) of Conducted Spurious Emission

Band :	CDMA2000 BC 10	Test Mode :	1xRTT RC1 SO55
--------	----------------	-------------	----------------

#### Conducted Spurious Emission Plot on Channel 476 (817.9 MHz)

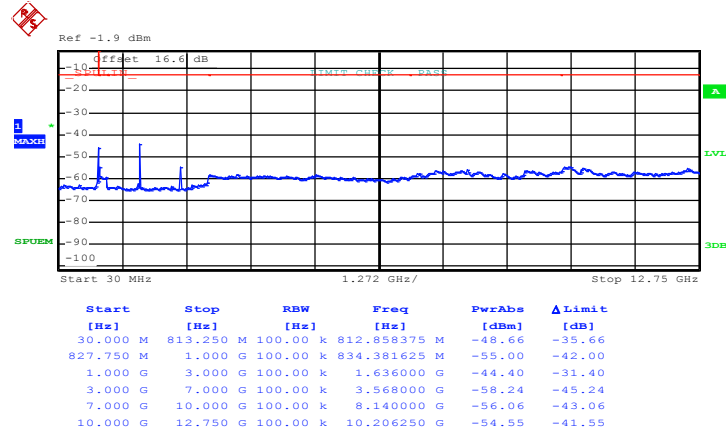

Date: 3.SEP.2014 09:45:34

#### Conducted Spurious Emission Plot on Channel 580 (820.5 MHz)

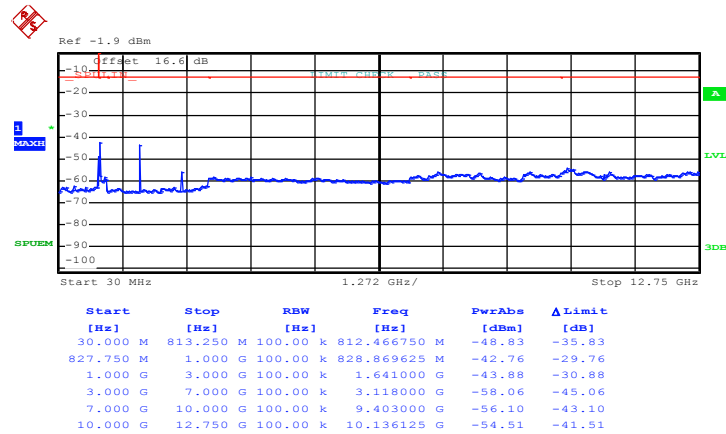

Date: 3.SEP.2014 09:45:57



Conducted Spurious Emission Plot on Channel 676 (822.9 MHz)

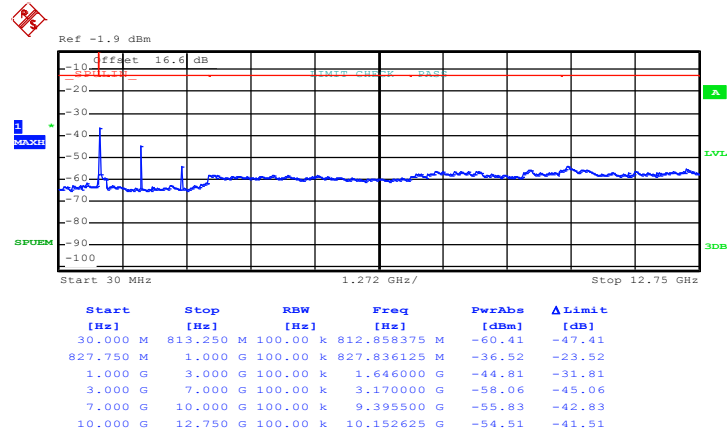

Date: 3.SEP.2014 09:46:32



Band :	CDMA2000 BC 10	Test Mode :	1xEV-DO Rev. 0
--------	----------------	-------------	----------------

Conducted Spurious Emission Plot on Channel 476 (817.9 MHz)

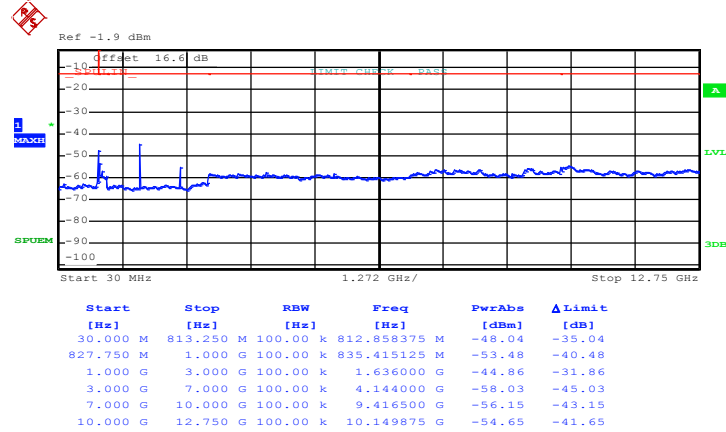

Date: 2.SEP.2014 18:39:20

Conducted Spurious Emission Plot on Channel 580 (820.5 MHz)

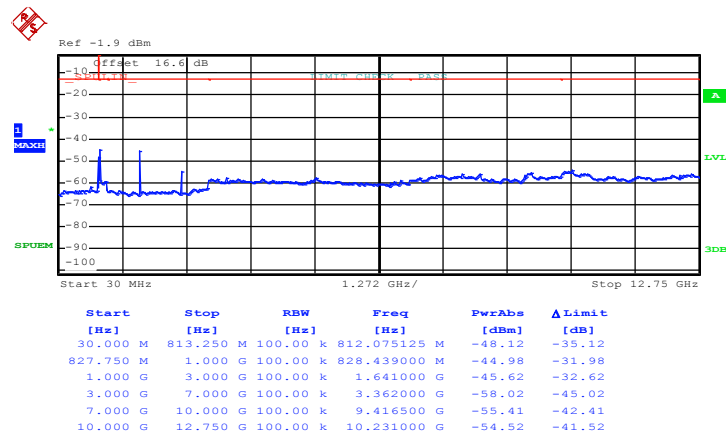

Date: 2.SEP.2014 18:38:54



Conducted Spurious Emission Plot on Channel 676 (822.9 MHz)

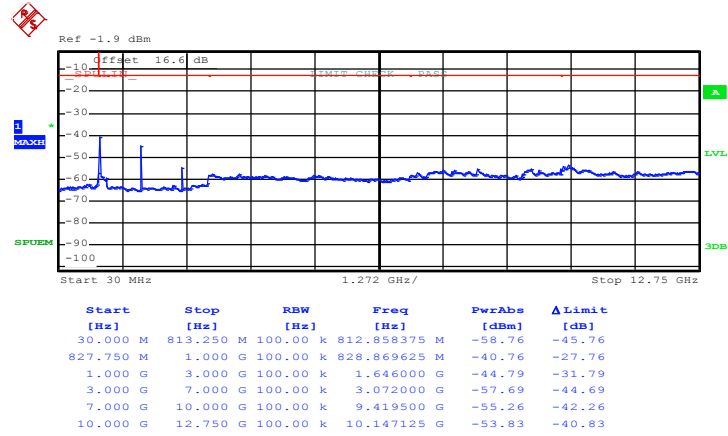

Date: 2.SEP.2014 18:38:29



## 3.5 Field Strength of Spurious Radiation Measurement

### 3.5.1 Description of Field Strength of Spurious Radiated Measurement

The radiated spurious emission was measured by substitution method according to ANSI / TIA / EIA-603-C-2004. The power of any emission FCC Part 90.691 on any frequency removed from the assigned frequency by more than 250 percent of the authorized bandwidth at least  $43 + 10 \log (P)$  dB. The spectrum is scanned from 30 MHz up to a frequency including its 10th harmonic.

The power of any emission outside of the authorized operating frequency ranges must be attenuated below the transmitter power (P) by a factor of at least  $43 + 10 \log_{10}(P[\text{Watts}])$  dB. The spectrum is scanned from 30 MHz up to a frequency including its 10th harmonic.

**Note:** Wireless charger configuration was evaluated.

### 3.5.2 Measuring Instruments

The measuring equipment is listed in the section 4 of this test report.

### 3.5.3 Test Procedures

1. The EUT was placed on a rotatable wooden table with 0.8 meter about ground.
2. The EUT was set 3 meters from the receiving antenna, which was mounted on the antenna tower.
3. The table was rotated 360 degrees to determine the position of the highest spurious emission.
4. The height of the receiving antenna is varied between one meter and four meters to search the maximum spurious emission for both horizontal and vertical polarizations.
5. Make the measurement with the spectrum analyzer's RBW = 1MHz, VBW = 3MHz, Sweep = 500ms, Taking the record of maximum spurious emission.
6. A horn antenna was substituted in place of the EUT and was driven by a signal generator.
7. Tune the output power of signal generator to the same emission level with EUT maximum spurious emission.
8. Taking the record of output power at antenna port.
9. Repeat step 7 to step 8 for another polarization.
10.  $\text{EIRP (dBm)} = \text{S.G. Power} - \text{Tx Cable Loss} + \text{Tx Antenna Gain}$
11.  $\text{ERP (dBm)} = \text{EIRP} - 2.15$
12. The RF fundamental frequency should be excluded against the limit line in the operating frequency band.
13. The limit line is derived from  $43 + 10 \log(P)$  dB below the transmitter power P(Watts)  
 $= P(W) - [43 + 10 \log(P)]$  (dB)  
 $= [30 + 10 \log(P)]$  (dBm) -  $[43 + 10 \log(P)]$  (dB)  
 $= -13 \text{dBm}$ .

### 3.5.4 Test Setup

For radiated emissions from 30MHz to 1GHz

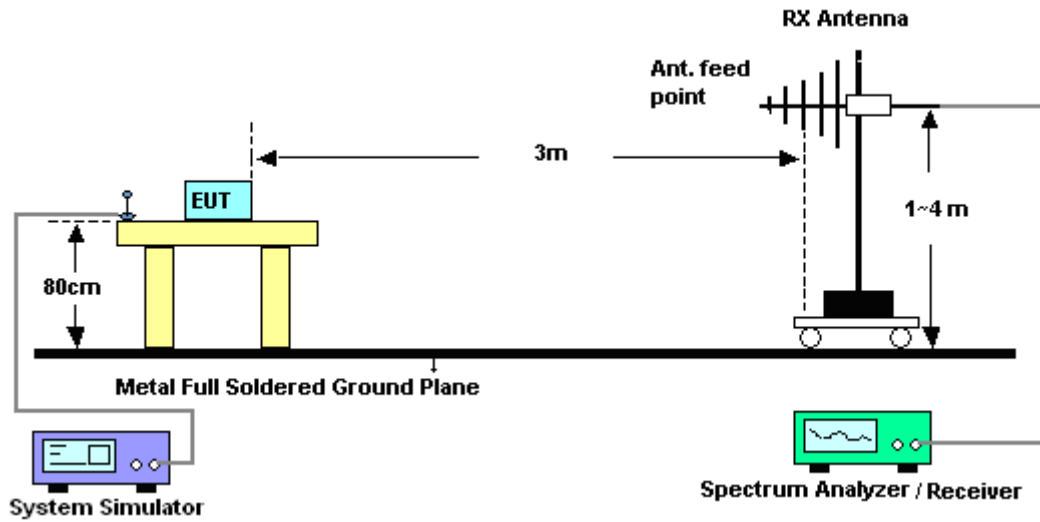

For radiated emissions above 1GHz

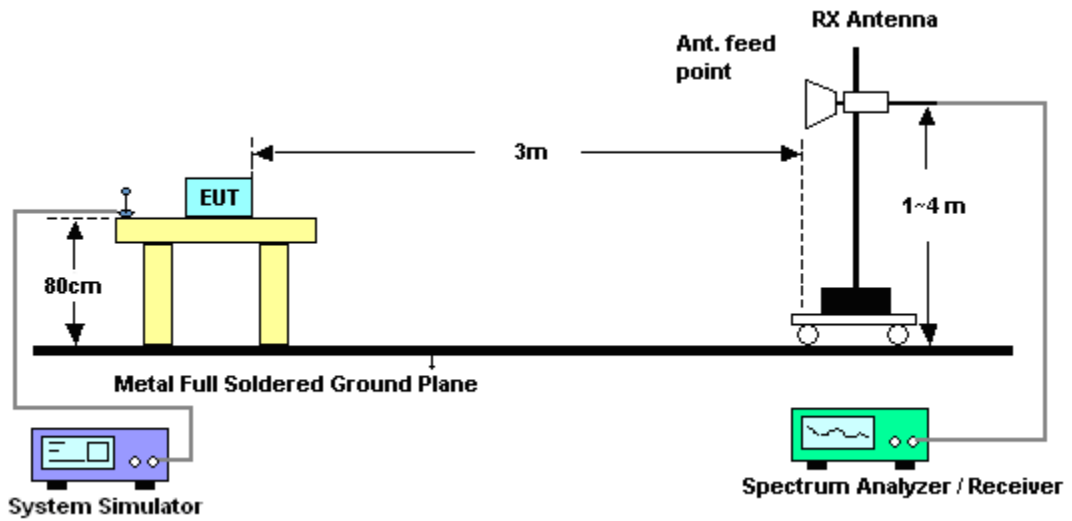



### 3.5.5 Test Result of Field Strength of Spurious Radiated

<Low Channel>

<b>Band :</b>	CDMA2000 BC10						<b>Temperature :</b>	23~24°C	
<b>Test Mode :</b>	1xRTT RC1 SO55						<b>Relative Humidity :</b>	46~48%	
<b>Test Engineer :</b>	Eric Shih						<b>Polarization :</b>	Horizontal	
<b>Remark :</b>	Spurious emissions within 30-1000MHz were found more than 20dB below limit line.								
Frequency ( MHz )	ERP ( dBm )	Limit ( dBm )	Over Limit ( dB )	SPA Reading ( dBm )	S.G. Power ( dBm )	TX Cable loss ( dB )	TX Antenna Gain ( dBi )	Polarization ( H/V )	Result
1632	-54.21	-13	-41.21	-62.56	-56.02	0.97	4.93	H	Pass
2453	-51.98	-13	-38.98	-64.53	-53.81	1.28	5.26	H	Pass
3271	-51.03	-13	-38.03	-64.83	-54.34	1.53	6.99	H	Pass

<b>Band :</b>	CDMA2000 BC10						<b>Temperature :</b>	23~24°C	
<b>Test Mode :</b>	1xRTT RC1 SO55						<b>Relative Humidity :</b>	46~48%	
<b>Test Engineer :</b>	Eric Shih						<b>Polarization :</b>	Vertical	
<b>Remark :</b>	Spurious emissions within 30-1000MHz were found more than 20dB below limit line.								
Frequency ( MHz )	ERP ( dBm )	Limit ( dBm )	Over Limit ( dB )	SPA Reading ( dBm )	S.G. Power ( dBm )	TX Cable loss ( dB )	TX Antenna Gain ( dBi )	Polarization ( H/V )	Result
1632	-52.52	-13	-39.52	-62.81	-54.33	0.97	4.93	V	Pass
2453	-49.87	-13	-36.87	-64.79	-51.7	1.28	5.26	V	Pass
3271	-49.96	-13	-36.96	-64.91	-53.27	1.53	6.99	V	Pass



<Middle Channel>

<b>Band :</b>	CDMA2000 BC10	<b>Temperature :</b>	23~24°C						
<b>Test Mode :</b>	1xRTT RC1 SO55	<b>Relative Humidity :</b>	46~48%						
<b>Test Engineer :</b>	Eric Shih	<b>Polarization :</b>	Horizontal						
<b>Remark :</b>	Spurious emissions within 30-1000MHz were found more than 20dB below limit line.								
Frequency ( MHz )	ERP ( dBm )	Limit ( dBm )	Over Limit ( dB )	SPA Reading ( dBm )	S.G. Power ( dBm )	TX Cable loss ( dB )	TX Antenna Gain ( dBi )	Polarization ( H/V )	Result
1641	-55.34	-13	-42.34	-63.46	-57.12	0.97	4.91	H	Pass
2461.5	-51.43	-13	-38.43	-64.24	-53.28	1.28	5.28	H	Pass
3282	-51.92	-13	-38.92	-65.14	-55.27	1.54	7.04	H	Pass

<b>Band :</b>	CDMA2000 BC10	<b>Temperature :</b>	23~24°C						
<b>Test Mode :</b>	1xRTT RC1 SO55	<b>Relative Humidity :</b>	46~48%						
<b>Test Engineer :</b>	Eric Shih	<b>Polarization :</b>	Vertical						
<b>Remark :</b>	Spurious emissions within 30-1000MHz were found more than 20dB below limit line.								
Frequency ( MHz )	ERP ( dBm )	Limit ( dBm )	Over Limit ( dB )	SPA Reading ( dBm )	S.G. Power ( dBm )	TX Cable loss ( dB )	TX Antenna Gain ( dBi )	Polarization ( H/V )	Result
1641	-53.24	-13	-40.24	-63.58	-55.02	0.97	4.91	V	Pass
2461.5	-51.33	-13	-38.33	-64.44	-53.18	1.28	5.28	V	Pass
3282	-50.84	-13	-37.84	-66	-54.19	1.54	7.04	V	Pass



<High Channel>

<b>Band :</b>	CDMA2000 BC10						<b>Temperature :</b>	23~24°C	
<b>Test Mode :</b>	1xRTT RC1 SO55						<b>Relative Humidity :</b>	46~48%	
<b>Test Engineer :</b>	Eric Shih						<b>Polarization :</b>	Horizontal	
<b>Remark :</b>	Spurious emissions within 30-1000MHz were found more than 20dB below limit line.								
Frequency ( MHz )	ERP ( dBm )	Limit ( dBm )	Over Limit ( dB )	SPA Reading ( dBm )	S.G. Power ( dBm )	TX Cable loss ( dB )	TX Antenna Gain ( dBi )	Polarization ( H/V )	Result
1648	-53.46	-13	-40.46	-61.93	-55.22	0.98	4.89	H	Pass
2469	-52.35	-13	-39.35	-64.97	-54.23	1.28	5.31	H	Pass
3292	-51.37	-13	-38.37	-64.64	-54.77	1.54	7.08	H	Pass

<b>Band :</b>	CDMA2000 BC10						<b>Temperature :</b>	23~24°C	
<b>Test Mode :</b>	1xRTT RC1 SO55						<b>Relative Humidity :</b>	46~48%	
<b>Test Engineer :</b>	Eric Shih						<b>Polarization :</b>	Vertical	
<b>Remark :</b>	Spurious emissions within 30-1000MHz were found more than 20dB below limit line.								
Frequency ( MHz )	ERP ( dBm )	Limit ( dBm )	Over Limit ( dB )	SPA Reading ( dBm )	S.G. Power ( dBm )	TX Cable loss ( dB )	TX Antenna Gain ( dBi )	Polarization ( H/V )	Result
1648	-52.45	-13	-39.45	-63.27	-54.21	0.98	4.89	V	Pass
2469	-51.79	-13	-38.79	-64.85	-53.67	1.28	5.31	V	Pass
3292	-49.51	-13	-36.51	-64.61	-52.91	1.54	7.08	V	Pass



<Low Channel>

<b>Band :</b>	CDMA2000 BC10						<b>Temperature :</b>	23~24°C	
<b>Test Mode :</b>	1xEV-DO Rev. 0						<b>Relative Humidity :</b>	46~48%	
<b>Test Engineer :</b>	Eric Shih						<b>Polarization :</b>	Horizontal	
<b>Remark :</b>	Spurious emissions within 30-1000MHz were found more than 20dB below limit line.								
Frequency ( MHz )	ERP ( dBm )	Limit ( dBm )	Over Limit ( dB )	SPA Reading ( dBm )	S.G. Power ( dBm )	TX Cable loss ( dB )	TX Antenna Gain ( dBi )	Polarization ( H/V )	Result
1632	-54.50	-13	-41.50	-62.56	-56.31	0.97	4.93	H	Pass
2453	-52.35	-13	-39.35	-64.53	-54.18	1.28	5.26	H	Pass
3271	-51.00	-13	-38.00	-64.83	-54.31	1.53	6.99	H	Pass

<b>Band :</b>	CDMA2000 BC10						<b>Temperature :</b>	23~24°C	
<b>Test Mode :</b>	1xEV-DO Rev. 0						<b>Relative Humidity :</b>	46~48%	
<b>Test Engineer :</b>	Eric Shih						<b>Polarization :</b>	Vertical	
<b>Remark :</b>	Spurious emissions within 30-1000MHz were found more than 20dB below limit line.								
Frequency ( MHz )	ERP ( dBm )	Limit ( dBm )	Over Limit ( dB )	SPA Reading ( dBm )	S.G. Power ( dBm )	TX Cable loss ( dB )	TX Antenna Gain ( dBi )	Polarization ( H/V )	Result
1632	-52.70	-13	-39.70	-62.81	-54.51	0.97	4.93	V	Pass
2453	-51.61	-13	-38.61	-64.79	-53.44	1.28	5.26	V	Pass
3271	-49.86	-13	-36.86	-64.91	-53.17	1.53	6.99	V	Pass



<Middle Channel>

<b>Band :</b>	CDMA2000 BC10	<b>Temperature :</b>	23~24°C						
<b>Test Mode :</b>	1xEV-DO Rev. 0	<b>Relative Humidity :</b>	46~48%						
<b>Test Engineer :</b>	Eric Shih	<b>Polarization :</b>	Horizontal						
<b>Remark :</b>	Spurious emissions within 30-1000MHz were found more than 20dB below limit line.								
Frequency ( MHz )	ERP ( dBm )	Limit ( dBm )	Over Limit ( dB )	SPA Reading ( dBm )	S.G. Power ( dBm )	TX Cable loss ( dB )	TX Antenna Gain ( dBi )	Polarization ( H/V )	Result
1642	-55.25	-13	-42.25	-63.46	-57.03	0.98	4.90	H	Pass
2461	-51.44	-13	-38.44	-64.24	-53.29	1.28	5.28	H	Pass
3282	-51.68	-13	-38.68	-65.14	-55.03	1.54	7.04	H	Pass

<b>Band :</b>	CDMA2000 BC10	<b>Temperature :</b>	23~24°C						
<b>Test Mode :</b>	1xEV-DO Rev. 0	<b>Relative Humidity :</b>	46~48%						
<b>Test Engineer :</b>	Eric Shih	<b>Polarization :</b>	Vertical						
<b>Remark :</b>	Spurious emissions within 30-1000MHz were found more than 20dB below limit line.								
Frequency ( MHz )	ERP ( dBm )	Limit ( dBm )	Over Limit ( dB )	SPA Reading ( dBm )	S.G. Power ( dBm )	TX Cable loss ( dB )	TX Antenna Gain ( dBi )	Polarization ( H/V )	Result
1641	-53.26	-13	-40.26	-63.58	-55.04	0.97	4.91	V	Pass
2461.5	-51.46	-13	-38.46	-64.44	-53.31	1.28	5.28	V	Pass
3282	-50.73	-13	-37.73	-66	-54.08	1.54	7.04	V	Pass



<High Channel>

<b>Band :</b>	CDMA2000 BC10	<b>Temperature :</b>	23~24°C						
<b>Test Mode :</b>	1xEV-DO Rev. 0	<b>Relative Humidity :</b>	46~48%						
<b>Test Engineer :</b>	Eric Shih	<b>Polarization :</b>	Horizontal						
<b>Remark :</b>	Spurious emissions within 30-1000MHz were found more than 20dB below limit line.								
Frequency ( MHz )	ERP ( dBm )	Limit ( dBm )	Over Limit ( dB )	SPA Reading ( dBm )	S.G. Power ( dBm )	TX Cable loss ( dB )	TX Antenna Gain ( dBi )	Polarization ( H/V )	Result
1768	-55.47	-13	-42.47	-63.73	-56.84	1.03	4.55	H	Pass
2652	-52.34	-13	-39.34	-64.99	-54.37	1.34	5.52	H	Pass
3536	-52.00	-13	-39.00	-65.76	-56.28	1.62	8.04	H	Pass

<b>Band :</b>	CDMA2000 BC10	<b>Temperature :</b>	23~24°C						
<b>Test Mode :</b>	1xEV-DO Rev. 0	<b>Relative Humidity :</b>	46~48%						
<b>Test Engineer :</b>	Eric Shih	<b>Polarization :</b>	Vertical						
<b>Remark :</b>	Spurious emissions within 30-1000MHz were found more than 20dB below limit line.								
Frequency ( MHz )	ERP ( dBm )	Limit ( dBm )	Over Limit ( dB )	SPA Reading ( dBm )	S.G. Power ( dBm )	TX Cable loss ( dB )	TX Antenna Gain ( dBi )	Polarization ( H/V )	Result
1768	-53.91	-13	-40.91	-64.76	-55.28	1.03	4.55	V	Pass
2652	-51.28	-13	-38.28	-64.86	-53.31	1.34	5.52	V	Pass
3536	-50.11	-13	-37.11	-65.24	-54.39	1.62	8.04	V	Pass



<WPC Charging Mode>

<Low Channel>

Band :	CDMA2000 BC10						Temperature :	23~24°C		
Test Mode :	1xRTT RC1 SO55						Relative Humidity :	46~48%		
Test Engineer :	Eric Shih						Polarization :	Horizontal		
Remark :	Spurious emissions within 30-1000MHz were found more than 20dB below limit line.									
Frequency ( MHz )	ERP ( dBm )	Limit ( dBm )	Over Limit ( dB )	SPA Reading ( dBm )	S.G. Power ( dBm )	TX Cable loss ( dB )	TX Antenna Gain ( dBi )	Polarization ( H/V )	Result	
1632	-57.21	-13	-44.21	-65.41	-59.02	0.97	4.93	H	Pass	
2453	-53.48	-13	-40.48	-65.76	-55.31	1.28	5.26	H	Pass	
3271	-53.52	-13	-40.52	-66.93	-56.83	1.53	6.99	H	Pass	

Band :	CDMA2000 BC10						Temperature :	23~24°C		
Test Mode :	1xRTT RC1 SO55						Relative Humidity :	46~48%		
Test Engineer :	Eric Shih						Polarization :	Vertical		
Remark :	Spurious emissions within 30-1000MHz were found more than 20dB below limit line.									
Frequency ( MHz )	ERP ( dBm )	Limit ( dBm )	Over Limit ( dB )	SPA Reading ( dBm )	S.G. Power ( dBm )	TX Cable loss ( dB )	TX Antenna Gain ( dBi )	Polarization ( H/V )	Result	
1632	-56.31	-13	-43.31	-66.66	-58.12	0.97	4.93	V	Pass	
2453	-51.48	-13	-38.48	-64.86	-53.31	1.28	5.26	V	Pass	
3271	-51.52	-13	-38.52	-66.71	-54.83	1.53	6.99	V	Pass	



<Middle Channel>

<b>Band :</b>	CDMA2000 BC10	<b>Temperature :</b>	23~24°C						
<b>Test Mode :</b>	1xRTT RC1 SO55	<b>Relative Humidity :</b>	46~48%						
<b>Test Engineer :</b>	Eric Shih	<b>Polarization :</b>	Horizontal						
<b>Remark :</b>	Spurious emissions within 30-1000MHz were found more than 20dB below limit line.								
Frequency ( MHz )	ERP ( dBm )	Limit ( dBm )	Over Limit ( dB )	SPA Reading ( dBm )	S.G. Power ( dBm )	TX Cable loss ( dB )	TX Antenna Gain ( dBi )	Polarization ( H/V )	Result
1641	-55.56	-13	-42.56	-65.09	-57.34	0.97	4.91	H	Pass
2461.5	-52.56	-13	-39.56	-66.5	-54.41	1.28	5.28	H	Pass
3282	-50.63	-13	-37.63	-66.96	-53.98	1.54	7.04	H	Pass

<b>Band :</b>	CDMA2000 BC10	<b>Temperature :</b>	23~24°C						
<b>Test Mode :</b>	1xRTT RC1 SO55	<b>Relative Humidity :</b>	46~48%						
<b>Test Engineer :</b>	Eric Shih	<b>Polarization :</b>	Vertical						
<b>Remark :</b>	Spurious emissions within 30-1000MHz were found more than 20dB below limit line.								
Frequency ( MHz )	ERP ( dBm )	Limit ( dBm )	Over Limit ( dB )	SPA Reading ( dBm )	S.G. Power ( dBm )	TX Cable loss ( dB )	TX Antenna Gain ( dBi )	Polarization ( H/V )	Result
1641	-54.25	-13	-41.25	-64.62	-56.03	0.97	4.91	V	Pass
2461.5	-53.42	-13	-40.42	-66.79	-55.27	1.28	5.28	V	Pass
3282	-51.46	-13	-38.46	-66.88	-54.81	1.54	7.04	V	Pass



<High Channel>

<b>Band :</b>	CDMA2000 BC10						<b>Temperature :</b>	23~24°C	
<b>Test Mode :</b>	1xRTT RC1 SO55						<b>Relative Humidity :</b>	46~48%	
<b>Test Engineer :</b>	Eric Shih						<b>Polarization :</b>	Horizontal	
<b>Remark :</b>	Spurious emissions within 30-1000MHz were found more than 20dB below limit line.								
Frequency ( MHz )	ERP ( dBm )	Limit ( dBm )	Over Limit ( dB )	SPA Reading ( dBm )	S.G. Power ( dBm )	TX Cable loss ( dB )	TX Antenna Gain ( dBi )	Polarization ( H/V )	Result
1646	-56.96	-13	-43.96	-65.64	-58.72	0.98	4.89	H	Pass
2469	-54.15	-13	-41.15	-66.66	-56.03	1.28	5.31	H	Pass
3292	-52.81	-13	-39.81	-66.13	-56.21	1.54	7.08	H	Pass

<b>Band :</b>	CDMA2000 BC10						<b>Temperature :</b>	23~24°C	
<b>Test Mode :</b>	1xRTT						<b>Relative Humidity :</b>	46~48%	
<b>Test Engineer :</b>	Eric Shih						<b>Polarization :</b>	Vertical	
<b>Remark :</b>	Spurious emissions within 30-1000MHz were found more than 20dB below limit line.								
Frequency ( MHz )	ERP ( dBm )	Limit ( dBm )	Over Limit ( dB )	SPA Reading ( dBm )	S.G. Power ( dBm )	TX Cable loss ( dB )	TX Antenna Gain ( dBi )	Polarization ( H/V )	Result
1646	-55.05	-13	-42.05	-65.35	-56.81	0.98	4.89	V	Pass
2469	-53.87	-13	-40.87	-66.7	-55.75	1.28	5.31	V	Pass
3292	-51.61	-13	-38.61	-66.82	-55.01	1.54	7.08	V	Pass

## 3.6 Frequency Stability Measurement

### 3.6.1 Description of Frequency Stability Measurement

The frequency stability shall be measured by variation of ambient temperature and variation of primary supply voltage to ensure that the fundamental emission stays within the authorized frequency block. The frequency stability of the transmitter shall be maintained within  $\pm 0.00025\%$  ( $\pm 2.5\text{ppm}$ ) of the center frequency according to FCC Part 90.213.

### 3.6.2 Measuring Instruments

The measuring equipment is listed in the section 4 of this test report.

### 3.6.3 Test Procedures for Temperature Variation

1. The EUT was set up in the thermal chamber and connected with the base station.
2. With power OFF, the temperature was decreased to  $-30^{\circ}\text{C}$  and the EUT was stabilized for three hours. Power was applied and the maximum change in frequency was recorded within one minute.
3. With power OFF, the temperature was raised in  $10^{\circ}\text{C}$  step up to  $50^{\circ}\text{C}$ . The EUT was stabilized at each step for at least half an hour. Power was applied and the maximum frequency change was recorded within one minute.

### 3.6.4 Test Procedures for Voltage Variation

1. The EUT was placed in a temperature chamber at  $25\pm 5^{\circ}\text{C}$  and connected with the base station.
2. The power supply voltage to the EUT was varied from BEP to 115% of the nominal value measured at the input to the EUT.
3. The variation in frequency was measured for the worst case.

### 3.6.5 Test Setup

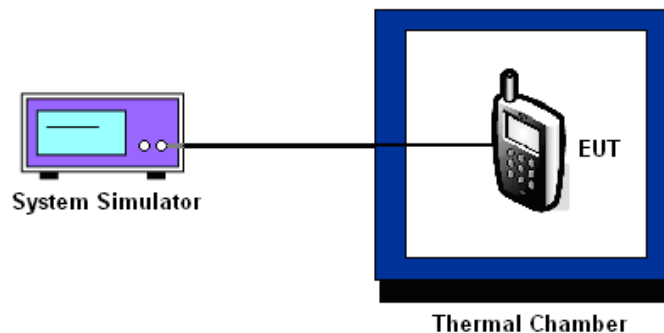



3.6.6 Test Result of Temperature Variation

<b>Band :</b>	CDMA2000 BC10 1xRTT RC1 SO55	<b>Channel :</b>	580
<b>Limit (ppm) :</b>	2.5	<b>Frequency :</b>	820.5

Temperature (°C)	Deviation (ppm)	Result
50	0.0475	PASS
40	0.0427	
30	0.0366	
20 (Ref.)	0.0000	
10	0.0024	
0	0.0012	
-10	0.0000	
-20	0.0012	
-30	0.0037	

<b>Band :</b>	CDMA2000 BC10 1xEV-DO Rev. 0	<b>Channel :</b>	580
<b>Limit (ppm) :</b>	2.5	<b>Frequency :</b>	820.5

Temperature (°C)	Deviation (ppm)	Result
50	0.0098	PASS
40	0.0037	
30	0.0012	
20 (Ref.)	0.0000	
10	0.0353	
0	0.0341	
-10	0.0366	
-20	0.0353	
-30	0.0390	



3.6.7 Test Result of Voltage Variation

Band & Channel	Mode	Voltage (Volt)	Deviation (ppm)	Limit (ppm)	Result
CDMA2000 BC10 CH580	1xRTT RC1 SO55	4.35	0.0341	2.5	PASS
		3.80	0.0012		
		BEP	0.0000		
	1xEV-DO Rev. 0	4.35	0.0024		
		3.80	0.0366		
		BEP	0.0353		

Note:

- 1. Normal Voltage = 3.80V.
- 2. Battery End Point (BEP) = 3.40 V.



## 4 List of Measuring Equipment

Instrument	Manufacturer	Model No.	Serial No.	Characteristics	Calibration Date	Test Date	Due Date	Remark
System Simulator	Rohde & Schwarz	CMU200	117995	N/A	Jul. 29, 2014	Sep. 02, 2014 ~ Sep. 03, 2014	Jul. 28, 2015	Conducted (TH02-HY)
Spectrum Analyzer	Rohde & Schwarz	FSP40	100055	9kHz~40GHz	Jun. 09, 2014	Sep. 02, 2014 ~ Sep. 03, 2014	Jun. 08, 2015	Conducted (TH02-HY)
Thermal Chamber	Ten Billion	TTH-D3SP	TBN-930701	N/A	Jul. 17, 2014	Sep. 02, 2014 ~ Sep. 03, 2014	Jul. 16, 2015	Conducted (TH02-HY)
Spectrum Analyzer	Rohde & Schwarz	FSV30	101749	10Hz ~ 30GHz	Feb. 10, 2014	Sep. 03, 2014~ Sep. 16, 2014	Feb. 09, 2015	Radiation (03CH07-HY)
Bilog Antenna	Schaffner	CBL6111C	2726	30MHz ~ 1GHz	Oct. 10, 2013	Sep. 03, 2014~ Sep. 16, 2014	Oct. 09, 2014	Radiation (03CH07-HY)
Double Ridge Horn Antenna	ESCO	3117	75962	1GHz~18GHz	Aug. 19, 2014	Sep. 03, 2014~ Sep. 16, 2014	Aug. 18, 2015	Radiation (03CH07-HY)
Signal Generator	Rohde & Schwarz	SMF100A	101107	100kHz~40GHz	May 23, 2014	Sep. 03, 2014~ Sep. 16, 2014	May 22, 2015	Radiation (03CH07-HY)
Double Ridge Horn Antenna	ESCO	3117	00066583	1GHz~18GHz	Jul. 24, 2014	Sep. 03, 2014~ Sep. 16, 2014	Jul. 23, 2015	Radiation (03CH07-HY)
Preamplifier	COM-POWER	PA-103A	161241	10 MHz ~ 1000MHz	Mar. 17, 2014	Sep. 03, 2014~ Sep. 16, 2014	Mar. 16, 2015	Radiation (03CH07-HY)
Preamplifier	Agilent	8449B	3008A02362	1 GHz~26.5 GHz	Nov. 29, 2013	Sep. 03, 2014~ Sep. 16, 2014	Nov. 28, 2014	Radiation (03CH07-HY)
Turn Table	ChainTek	ChainTek 3000	N/A	0 ~ 360 degree	N/A	Sep. 03, 2014~ Sep. 16, 2014	N/A	Radiation (03CH07-HY)
Antenna Mast	ChainTek	ChainTek 3000	N/A	N/A	N/A	Sep. 03, 2014~ Sep. 16, 2014	N/A	Radiation (03CH07-HY)



## 5 Uncertainty of Evaluation

### Uncertainty of Radiated Emission Measurement (30 MHz ~ 1000 MHz)

Measuring Uncertainty for a Level of Confidence of 95% ( $U = 2Uc(y)$ )	4.50
---	------