



FCC RF Test Report

APPLICANT : Motorola Mobility, LLC
EQUIPMENT : Mobile Cellular Phone
BRAND NAME : Motorola
MODEL NAME : 4054
FCC ID : IHDT56QD1
STANDARD : FCC Part 15 Subpart C §15.247
CLASSIFICATION : (DSS) Spread Spectrum Transmitter

The product was received on Aug. 06, 2014 and testing was completed on Sep. 15, 2014. We, SPORTON INTERNATIONAL INC., would like to declare that the tested sample has been evaluated in accordance with the test procedures and has been in compliance with the applicable technical standards.

The test results in this report apply exclusively to the tested model / sample. Without written approval of SPORTON INTERNATIONAL INC., the test report shall not be reproduced except in full.

Reviewed by: Joseph Lin / Supervisor

Approved by: Jones Tsai / Manager



SPORTON INTERNATIONAL INC.

No. 52, Hwa Ya 1st Rd., Hwa Ya Technology Park, Kwei-Shan Hsiang, Tao Yuan Hsien, Taiwan, R.O.C.

SPORTON INTERNATIONAL INC.

TEL : 886-3-327-3456

FAX : 886-3-328-4978

FCC ID : IHDT56QD1

Page Number : 1 of 75

Report Issued Date : Sep. 30, 2014

Report Version : Rev. 01

Report Template No.: BU5-FR15CBT Version 1.1



TABLE OF CONTENTS

REVISION HISTORY..... 3

SUMMARY OF TEST RESULT 4

1 GENERAL DESCRIPTION..... 5

 1.1 Applicant 5

 1.2 Manufacturer..... 5

 1.3 Product Feature of Equipment Under Test..... 5

 1.4 Product Specification subjective to this standard 6

 1.5 Modification of EUT 6

 1.6 Testing Location 6

 1.7 Applicable Standards..... 7

2 TEST CONFIGURATION OF EQUIPMENT UNDER TEST..... 8

 2.1 Descriptions of Test Mode 8

 2.2 Test Mode..... 9

 2.3 Connection Diagram of Test System..... 10

 2.4 Support Unit used in test configuration and system 12

 2.5 EUT Operation Test Setup 12

 2.6 Measurement Results Explanation Example..... 12

3 TEST RESULT 13

 3.1 Number of Channel Measurement 13

 3.2 Hopping Channel Separation Measurement 15

 3.3 Dwell Time Measurement..... 22

 3.4 20dB and 99% Bandwidth Measurement 25

 3.5 Peak Output Power Measurement 38

 3.6 Conducted Band Edges Measurement..... 40

 3.7 Conducted Spurious Emission Measurement 47

 3.8 Radiated Band Edges and Spurious Emission Measurement 57

 3.9 AC Conducted Emission Measurement..... 63

 3.10 Antenna Requirements..... 73

4 LIST OF MEASURING EQUIPMENT..... 74

5 UNCERTAINTY OF EVALUATION..... 75

APPENDIX A. TEST RESULT OF RADIATED EMISSION



SUMMARY OF TEST RESULT

Report Section	FCC Rule	Description	Limit	Result	Remark
3.1	15.247(a)(1)	Number of Channels	≥ 15Chs	Pass	-
3.2	15.247(a)(1)	Hopping Channel Separation	≥ 2/3 of 20dB BW	Pass	-
3.3	15.247(a)(1)	Dwell Time of Each Channel	≤ 0.4sec in 31.6sec period	Pass	-
3.4	15.247(a)(1)	20dB Bandwidth	NA	Pass	-
3.4	-	99% Bandwidth	-	Pass	-
3.5	15.247(b)(1)	Peak Output Power	≤ 125 mW	Pass	-
3.6	15.247(d)	Conducted Band Edges	≤ 20dBc	Pass	-
3.7	15.247(d)	Conducted Spurious Emission	≤ 20dBc	Pass	-
3.8	15.247(d)	Radiated Band Edges and Radiated Spurious Emission	15.209(a) & 15.247(d)	Pass	Under limit 12.84 dB at 169.050 MHz
3.9	15.207	AC Conducted Emission	15.207(a)	Pass	Under limit 14.00 dB at 1.198 MHz
3.10	15.203 & 15.247(b)	Antenna Requirement	N/A	Pass	-



1 General Description

1.1 Applicant

Motorola Mobility, LLC

222 W Merchandise Mart Plaza, Suite 1800, Chicago, IL 60654, United States

1.2 Manufacturer

Motorola Mobility, LLC

222 W Merchandise Mart Plaza, Suite 1800, Chicago, IL 60654, United States

1.3 Product Feature of Equipment Under Test

Product Feature	
Equipment	Mobile Cellular Phone
Brand Name	Motorola
Model Name	4054
FCC ID	IHDT56QD1
IMEI	990005300017812 990005300016731
EUT supports Radios application	CDMA/EV-DO/GSM/EGPRS/WCDMA/HSPA/LTE/NFC 2.4GHz WLAN 11b/g/n HT20 WLAN 11ac VHT20 5GHz WLAN 11a/n HT20/HT40 WLAN 11ac VHT20/VHT40/VHT80 Bluetooth v3.0 EDR Bluetooth v4.0 - LE
HW Version	P2
EUT Stage	Identical Prototype

Remark: The above EUT's information was declared by manufacturer. Please refer to the specifications or user's manual for more detailed description.

Accessory List	
AC Adapter	Brand Name : Motorola
	Model Name : SPN5864A
Earphone	Brand Name : Motorola
	Model Name : SJYN1305A
USB Cable	Brand Name : Motorola
	Model Name : SKN6448A
Battery	Brand Name : LG
	Model Name : EZ30



1.4 Product Specification subjective to this standard

Product Specification subjective to this standard	
Tx/Rx Frequency Range	2402 MHz ~ 2480 MHz
Number of Channels	79
Carrier Frequency of Each Channel	2402+n*1 MHz; n=0~78
Maximum Output Power to Antenna	Bluetooth BR(1Mbps) : 9.85 dBm (0.0097 W) Bluetooth EDR (2Mbps) : 8.91 dBm (0.0078 W) Bluetooth EDR (3Mbps) : 9.23 dBm (0.0084 W)
99% Occupied Bandwidth	Bluetooth BR(1Mbps) : 0.896MHz Bluetooth EDR (2Mbps) : 1.208MHz Bluetooth EDR (3Mbps) : 1.184MHz
Antenna Type	Monopole(IFA) Antenna with gain -3.00 dBi
Type of Modulation	Bluetooth BR (1Mbps) : GFSK Bluetooth EDR (2Mbps) : $\pi/4$ -DQPSK Bluetooth EDR (3Mbps) : 8-DPSK

1.5 Modification of EUT

No modifications are made to the EUT during all test items.

1.6 Testing Location

Sporton Lab is accredited to ISO 17025 by Taiwan Accreditation Foundation (TAF code : 1190) and the FCC designation No. TW1022 under the FCC 2.948(e) by Mutual Recognition Agreement (MRA) in FCC Test.

Test Site	SPORTON INTERNATIONAL INC.		
Test Site Location	No. 52, Hwa Ya 1 st Rd., Hwa Ya Technology Park, Kwei-Shan Hsiang, Tao Yuan Hsien, Taiwan, R.O.C. TEL: +886-3-327-3456 FAX: +886-3-328-4978		
Test Site No.	Sporton Site No.		
	TH02-HY	CO05-HY	03CH06-HY



1.7 Applicable Standards

According to the specifications of the manufacturer, the EUT must comply with the requirements of the following standards:

- ♦ FCC Part 15 Subpart C §15.247
- ♦ FCC Public Notice DA 00-705
- ♦ KDB 648474 D03 Handset Wireless Chargers Battery Covers v01r02
- ♦ ANSI C63.4-2003

Remark:

1. All test items were verified and recorded according to the standards and without any deviation during the test.
2. This EUT has also been tested and complied with the requirements of FCC Part 15, Subpart B, recorded in a separate test report.



2 Test Configuration of Equipment Under Test

2.1 Descriptions of Test Mode

Preliminary tests were performed in different data rates and recorded the RF output power in the following table:

Channel	Frequency	Bluetooth RF Output Power		
		Data Rate / Modulation		
		GFSK	$\pi/4$ -DQPSK	8-DPSK
		1Mbps	2Mbps	3Mbps
Ch00	2402MHz	7.49 dBm	6.77 dBm	7.10 dBm
Ch39	2441MHz	9.85 dBm	8.91 dBm	9.23 dBm
Ch78	2480MHz	8.39 dBm	7.44 dBm	7.76 dBm

Channel	Frequency	Bluetooth Average Power		
		Data Rate / Modulation		
		GFSK	$\pi/4$ -DQPSK	8-DPSK
		1Mbps	2Mbps	3Mbps
Ch00	2402MHz	7.17 dBm	4.16 dBm	4.13 dBm
Ch39	2441MHz	9.63 dBm	6.29 dBm	6.30 dBm
Ch78	2480MHz	8.15 dBm	4.84 dBm	4.85 dBm

Remark:

1. All the test data for each data rate were verified, but only the worst case was reported.
 2. The data rate was set in 1Mbps for all the test items due to the highest RF output power.
- a. The EUT has been associated with peripherals and configuration operated in a manner tended to maximize its emission characteristics in a typical application. Frequency range investigated: conduction (150 kHz to 30 MHz), radiation (9 kHz to the 10th harmonic of the highest fundamental frequency or to 40 GHz, whichever is lower). Pre-scanned tests, X, Y, Z in three orthogonal panels, and different data rates were conducted to determine the final configuration (X plane as worst plane) from all possible combinations, and the worst mode of radiated spurious emissions is Bluetooth 1Mbps mode, and recorded in this report.
- b. AC power line Conducted Emission was tested under maximum output power.



2.2 Test Mode

The following summary table is showing all test modes to demonstrate in compliance with the standard.

Summary table of Test Cases			
Test Item	Data Rate / Modulation		
	Bluetooth BR 1Mbps GFSK	Bluetooth EDR 2Mbps $\pi/4$ -DQPSK	Bluetooth EDR 3Mbps 8-DPSK
Conducted Test Cases	Mode 1: CH00_2402 MHz Mode 2: CH39_2441 MHz Mode 3: CH78_2480 MHz	Mode 4: CH00_2402 MHz Mode 5: CH39_2441 MHz Mode 6: CH78_2480 MHz	Mode 7: CH00_2402 MHz Mode 8: CH39_2441 MHz Mode 9: CH78_2480 MHz
Radiated Test Cases	Bluetooth BR 1Mbps GFSK		
	Mode 1: CH00_2402 MHz Mode 2: CH39_2441 MHz Mode 3: CH78_2480 MHz Mode 4: CH39_2441 MHz with WPC Charging		
AC Conducted Emission	Mode 1 :GSM850 Idle + Bluetooth Link + WLAN(2.4GHz) Link + MP3 + Earphone + USB Cable (Charging from Adapter)		
Remark: <ol style="list-style-type: none"> For radiated test cases, the worst mode data rate 1Mbps was reported only, because this data rate has the highest RF output power at preliminary tests, and the conducted spurious emissions and conducted band edge measurement for each data rate are no worse than 1Mbps, and no other significantly frequencies found in conducted spurious emission. All modes and data rates and positions were investigated, and the wireless charger configuration was evaluated. 			

2.3 Connection Diagram of Test System

<Bluetooth Tx Mode>

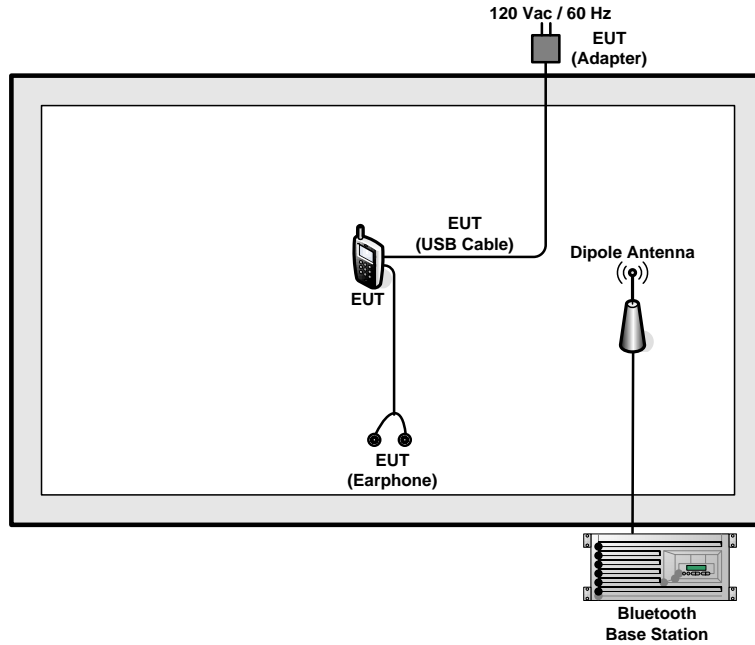

<Bluetooth Tx with CHARGER PAD Mode>

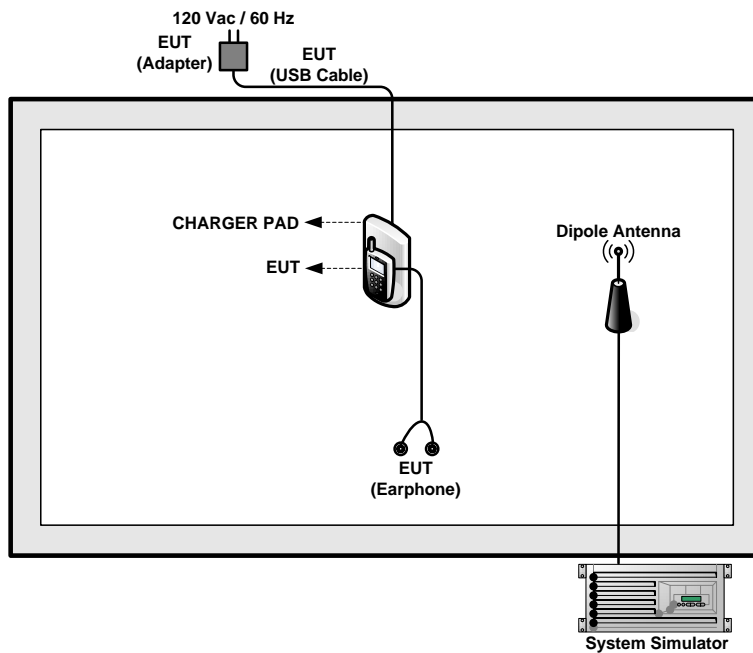

<AC Conducted Emission Mode>

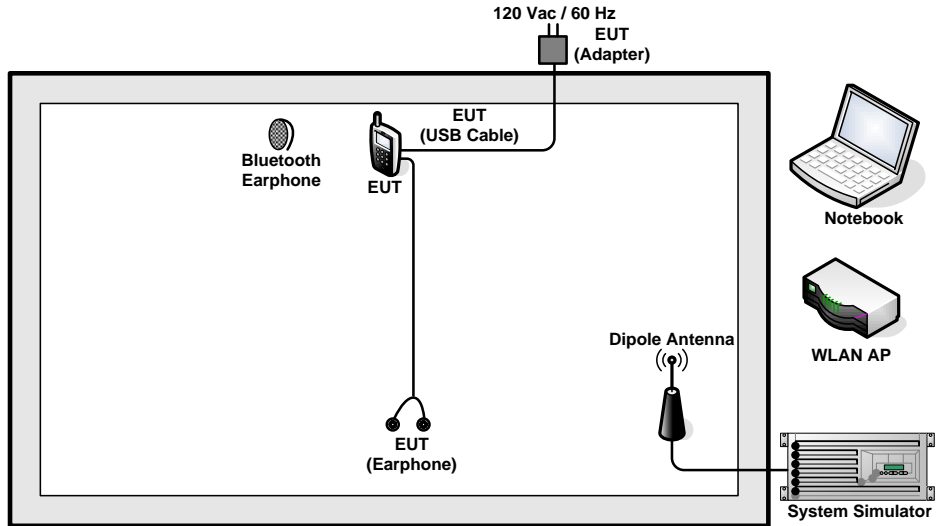



2.4 Support Unit used in test configuration and system

Item	Equipment	Trade Name	Model Name	FCC ID	Data Cable	Power Cord
1.	System Simulator	R&S	CMU 200	N/A	N/A	Unshielded, 1.8 m
2.	Bluetooth Base Station	R&S	CBT32	N/A	N/A	Unshielded, 1.8 m
3.	Bluetooth Earphone	Sony Ericsson	MW600	PY7DDA-2029	N/A	N/A
4.	WLAN AP	D-Link	DIR-628	KA2DIR628A2	N/A	Unshielded, 1.8 m
5.	CHARGER PAD	SAMSUNG	EP-P100IEWE	A3LEPP100IJWU	N/A	shielded, 1.5 m
6.	Notebook	DELL	Latitude E6320	FCC DoC/ Contains FCC ID: QDS-BRCM1054	N/A	AC I/P: Unshielded, 1.2 m DC O/P: Shielded, 1.8 m

2.5 EUT Operation Test Setup

For Bluetooth function, the RF utility, “CMD” was installed in Notebook which was programmed in order to make the EUT get into the engineering modes to contact with Bluetooth base station for continuous transmitting and receiving signals.

2.6 Measurement Results Explanation Example

For all conducted test items:

The offset level is set in the spectrum analyzer to compensate the RF cable loss and attenuator factor between EUT conducted output port and spectrum analyzer. With the offset compensation, the spectrum analyzer reading level is exactly the EUT RF output level.

Example:

The spectrum analyzer offset is derived from RF cable loss and attenuator factor.

Offset = RF cable loss + attenuator factor.

Following shows an offset computation example with cable loss 4.2 dB and 10dB attenuator.

$$\begin{aligned} \text{Offset(dB)} &= \text{RF cable loss(dB)} + \text{attenuator factor(dB)}. \\ &= 4.2 + 10 = 14.2 \text{ (dB)} \end{aligned}$$

3 Test Result

3.1 Number of Channel Measurement

3.1.1 Limits of Number of Hopping Frequency

Frequency hopping systems in the 2400-2483.5 MHz band shall use at least 15 channels.

3.1.2 Measuring Instruments

The measuring equipment is listed in the section 4 of this test report.

3.1.3 Test Procedure

1. The testing follows FCC Public Notice DA 00-705 Measurement Guidelines.
2. The RF output of EUT was connected to the spectrum analyzer by RF cable and attenuator. The path loss was compensated to the results for each measurement.
3. Set to the maximum power setting and enable the EUT transmit continuously.
4. Enable the EUT hopping function.
5. Use the following spectrum analyzer settings: Span = the frequency band of operation; RBW \geq 1% of the span; VBW \geq RBW; Sweep = auto; Detector function = peak; Trace = max hold.
6. The number of hopping frequency used is defined as the number of total channel.
7. Record the measurement data derived from spectrum analyzer.

3.1.4 Test Setup

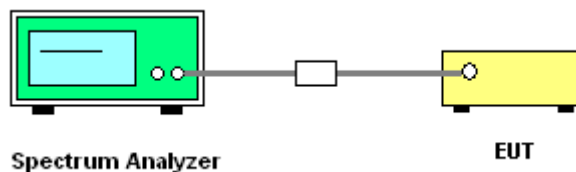

3.1.5 Test Result of Number of Hopping Frequency

Test Mode :	1Mbps	Temperature :	24~26°C
Test Engineer :	Alen Tsui	Relative Humidity :	50~53%
Number of Hopping (Channel)	Adaptive Frequency Hopping (Channel)	Limits (Channel)	Pass/Fail
79	20	> 15	Pass



Number of Hopping Channel Plot on Channel 00 - 78

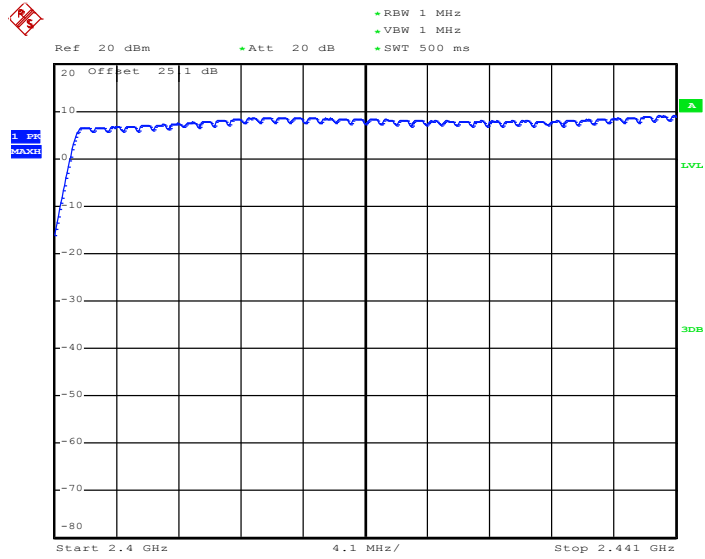

Date: 11.SEP.2014 08:44:35

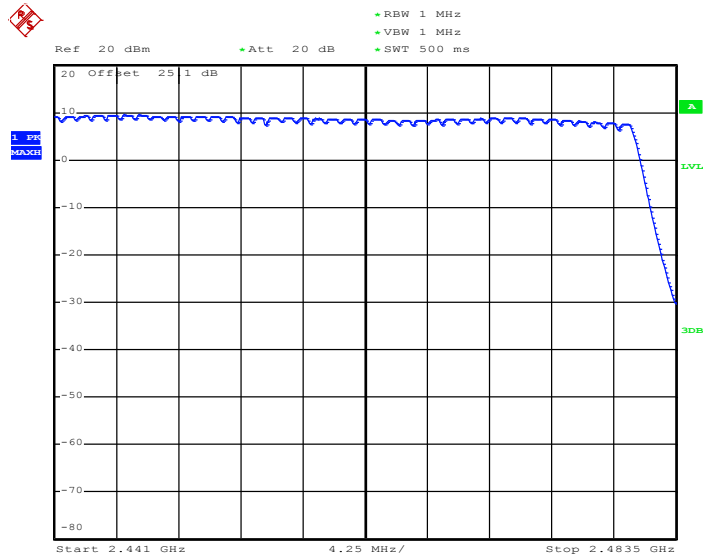

Date: 11.SEP.2014 08:48:21

3.2 Hopping Channel Separation Measurement

3.2.1 Limit of Hopping Channel Separation

Frequency hopping systems operating in the 2400-2483.5 MHz band may have hopping channel carrier frequencies that are separated by 25 kHz or two-thirds of the 20 dB bandwidth of the hopping channel, whichever is greater.

3.2.2 Measuring Instruments

The measuring equipment is listed in the section 4 of this test report.

3.2.3 Test Procedures

1. The testing follows FCC Public Notice DA 00-705 Measurement Guidelines.
2. The RF output of EUT was connected to the spectrum analyzer by RF cable and attenuator. The path loss was compensated to the results for each measurement.
3. Set to the maximum power setting and enable the EUT transmit continuously.
4. Enable the EUT hopping function.
5. Use the following spectrum analyzer settings:
Span = wide enough to capture the peaks of two adjacent channels; RBW \geq 1% of the span;
VBW \geq RBW; Sweep = auto; Detector function = peak; Trace = max hold.
6. Measure and record the results in the test report.

3.2.4 Test Setup

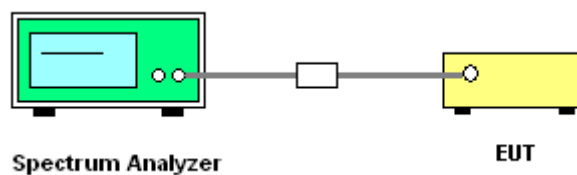



3.2.5 Test Result of Hopping Channel Separation

Test Mode :	1Mbps	Temperature :	24~26°C
Test Engineer :	Alen Tsui	Relative Humidity :	50~53%

Channel	Frequency (MHz)	Frequency Separation (MHz)	(2/3 of 20dB BW) Limits (MHz)	Pass/Fail
00	2402	1.002	0.6507	Pass
39	2441	1.002	0.6507	Pass
78	2480	1.002	0.6720	Pass

Channel Separation Plot on Channel 00 - 01

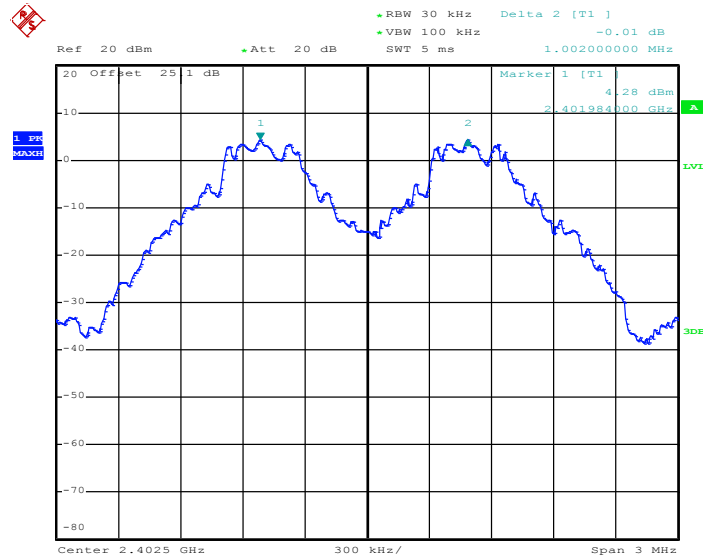

Date: 10.SEP.2014 16:24:12



Channel Separation Plot on Channel 39 - 40

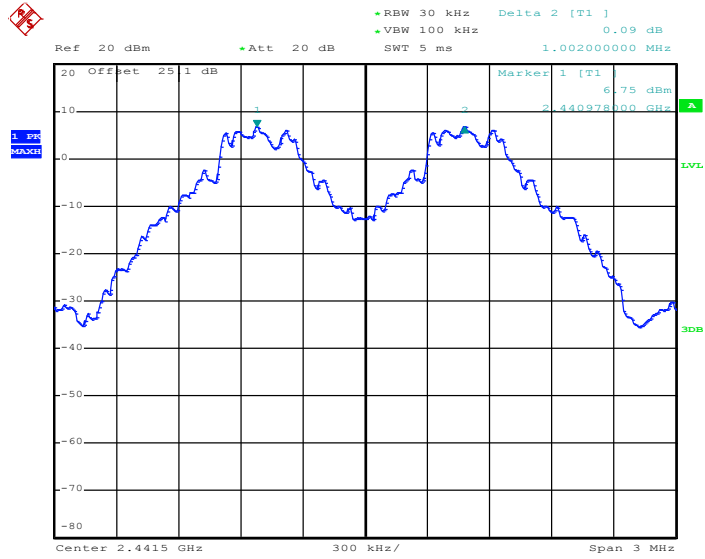

Date: 10.SEP.2014 16:25:35

Channel Separation Plot on Channel 77 - 78

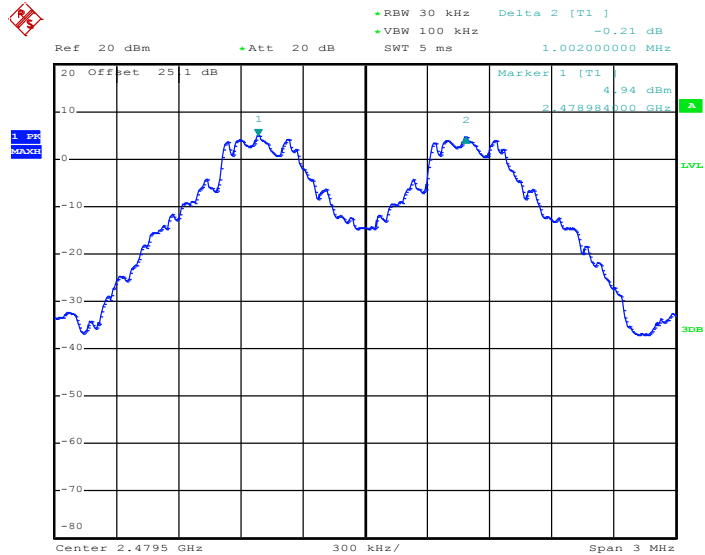

Date: 11.SEP.2014 08:37:38



Test Mode :	2Mbps	Temperature :	24~26°C
Test Engineer :	Alen Tsui	Relative Humidity :	50~53%

Channel	Frequency (MHz)	Frequency Separation (MHz)	(2/3 of 20dB BW) Limits (MHz)	Pass/Fail
00	2402	1.002	0.9040	Pass
39	2441	1.002	0.9040	Pass
78	2480	1.002	0.9040	Pass

Channel Separation Plot on Channel 00 - 01

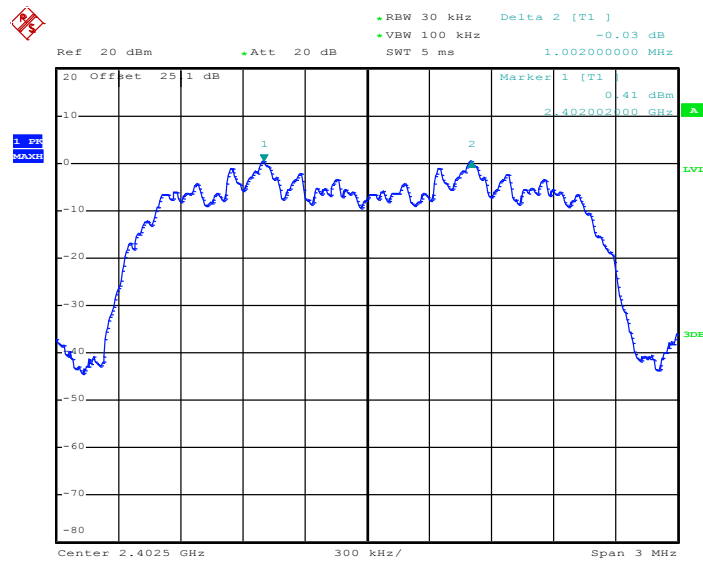

Date: 15.SEP.2014 21:19:37



Channel Separation Plot on Channel 39 - 40

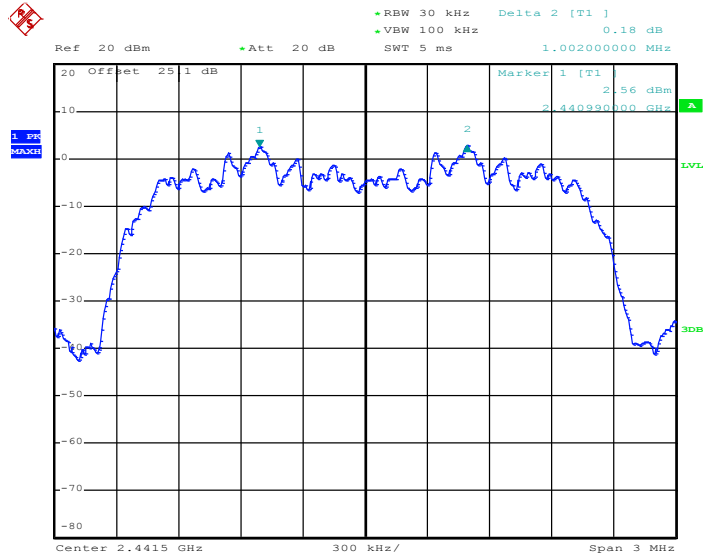

Date: 15.SEP.2014 20:46:04

Channel Separation Plot on Channel 77 - 78

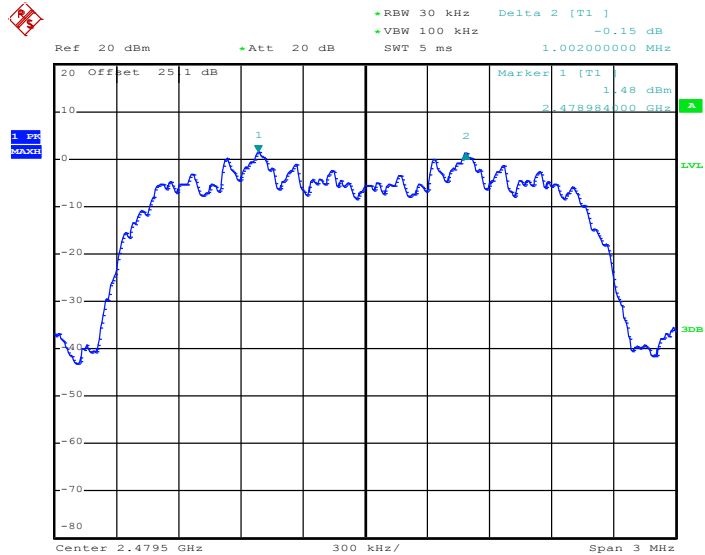

Date: 15.SEP.2014 20:49:06



Test Mode :	3Mbps	Temperature :	24~26°C
Test Engineer :	Alen Tsui	Relative Humidity :	50~53%

Channel	Frequency (MHz)	Frequency Separation (MHz)	(2/3 of 20dB BW) Limits (MHz)	Pass/Fail
00	2402	1.002	0.8800	Pass
39	2441	1.002	0.8800	Pass
78	2480	1.002	0.8800	Pass

Channel Separation Plot on Channel 00 - 01

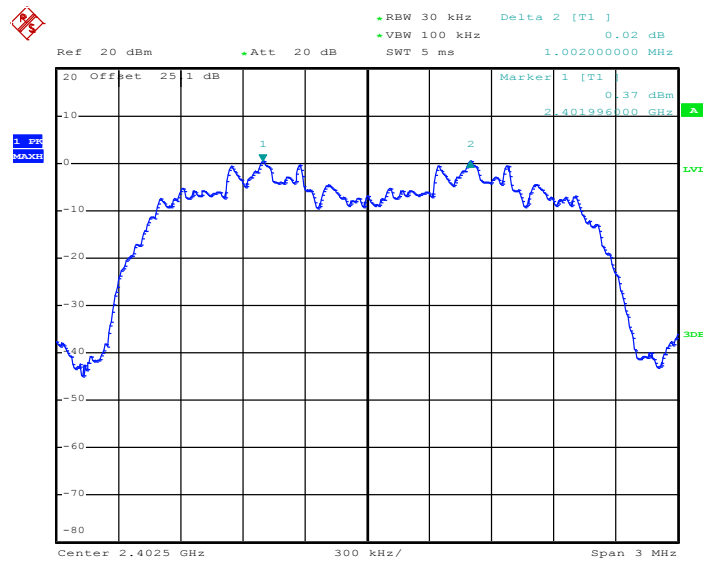

Date: 15.SEP.2014 21:12:41



Channel Separation Plot on Channel 39 - 40

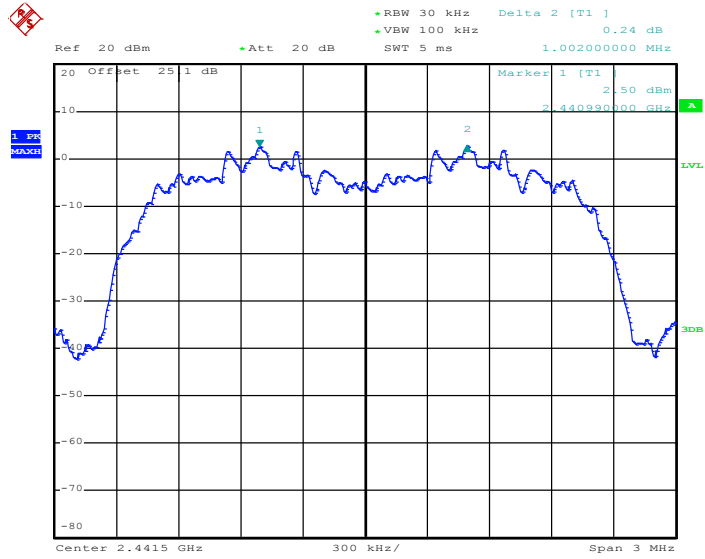

Date: 15.SEP.2014 20:51:30

Channel Separation Plot on Channel 77 - 78

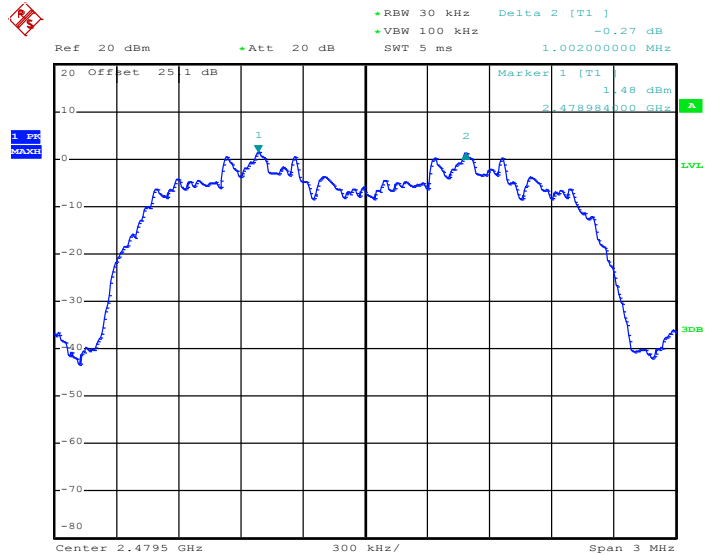

Date: 15.SEP.2014 21:15:06

3.3 Dwell Time Measurement

3.3.1 Limit of Dwell Time

The average time of occupancy on any channel shall not be greater than 0.4 seconds within a period of 0.4 seconds multiplied by the number of hopping channels employed.

3.3.2 Measuring Instruments

The measuring equipment is listed in the section 4 of this test report.

3.3.3 Test Procedures

1. The testing follows FCC Public Notice DA 00-705 Measurement Guidelines.
2. The RF output of EUT was connected to the spectrum analyzer by RF cable and attenuator. The path loss was compensated to the results for each measurement.
3. Set to the maximum power setting and enable the EUT transmit continuously.
4. Enable the EUT hopping function.
5. Use the following spectrum analyzer settings: Span = zero span, centered on a hopping channel; RBW = 1 MHz; VBW \geq RBW; Sweep = as necessary to capture the entire dwell time per hopping channel; Detector function = peak; Trace = max hold.
6. Measure and record the results in the test report.

3.3.4 Test Setup

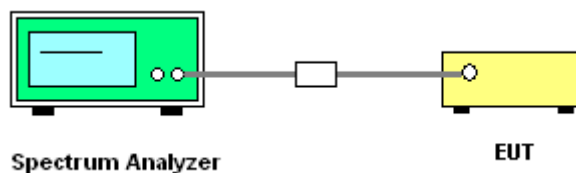



3.3.5 Test Result of Dwell Time

Test Mode :	DH5	Temperature :	24~26°C
Test Engineer :	Alen Tsui	Relative Humidity :	50~53%

Mode	Hopping Channel Number	Hops Over Occupancy Time(hops)	Package Transfer Time (msec)	Dwell Time (sec)	Limits (sec)	Pass/Fail
Normal	79	106.67	2.90	0.31	0.4	Pass
AFH	20	53.33	2.90	0.16	0.4	Pass

Remark:

- In normal mode, hopping rate is 1600 hops/s with 6 slots in 79 hopping channels.
 With channel hopping rate (1600 / 6 / 79) in Occupancy Time Limit (0.4 x 79) (s),
 Hops Over Occupancy Time comes to (1600 / 6 / 79) x (0.4 x 79) = 106.67 hops.
- In AFH mode, hopping rate is 800 hops/s with 6 slots in 20 hopping channels.
 With channel hopping rate (800 / 6 / 20) in Occupancy Time Limit (0.4 x 20) (s),
 Hops Over Occupancy Time comes to (800 / 6 / 20) x (0.4 x 20) = 53.33 hops.
- Dwell Time(s) = Hops Over Occupancy Time (hops) x Package Transfer Time



Package Transfer Time Plot

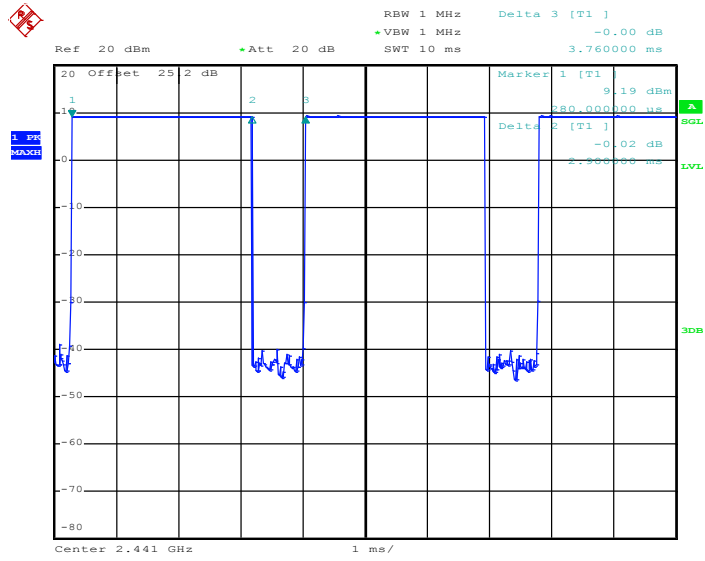

Date: 23.AUG.2014 01:22:52

3.4 20dB and 99% Bandwidth Measurement

3.4.1 Limit of 20dB and 99% Bandwidth

Reporting only

3.4.2 Measuring Instruments

The measuring equipment is listed in the section 4 of this test report.

3.4.3 Test Procedures

1. The testing follows FCC Public Notice DA 00-705 Measurement Guidelines.
2. The RF output of EUT was connected to the spectrum analyzer by RF cable and attenuator. The path loss was compensated to the results for each measurement.
3. Set to the maximum power setting and enable the EUT transmit continuously.
4. Use the following spectrum analyzer settings for 20dB Bandwidth measurement.
Span = approximately 2 to 3 times the 20 dB bandwidth, centered on a hopping channel;
RBW \geq 1% of the 20 dB bandwidth; VBW \geq RBW; Sweep = auto; Detector function = peak;
Trace = max hold.
5. Use the following spectrum analyzer settings for 99 % Bandwidth measurement.
For 99% Bandwidth measurement, the RBW=30kHz, and VBW = 100kHz. Sweep = auto ;
Detector function = sample. Trace = max hold.
6. Measure and record the results in the test report.

3.4.4 Test Setup

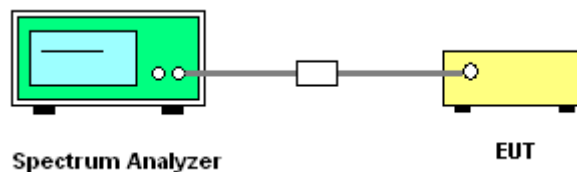



3.4.5 Test Result of 20dB Bandwidth

Test Mode :	1Mbps	Temperature :	24~26°C
Test Engineer :	Alen Tsui	Relative Humidity :	50~53%

Channel	Frequency (MHz)	20dB Bandwidth (MHz)
00	2402	0.976
39	2441	0.976
78	2480	1.008

20 dB Bandwidth Plot on Channel 00

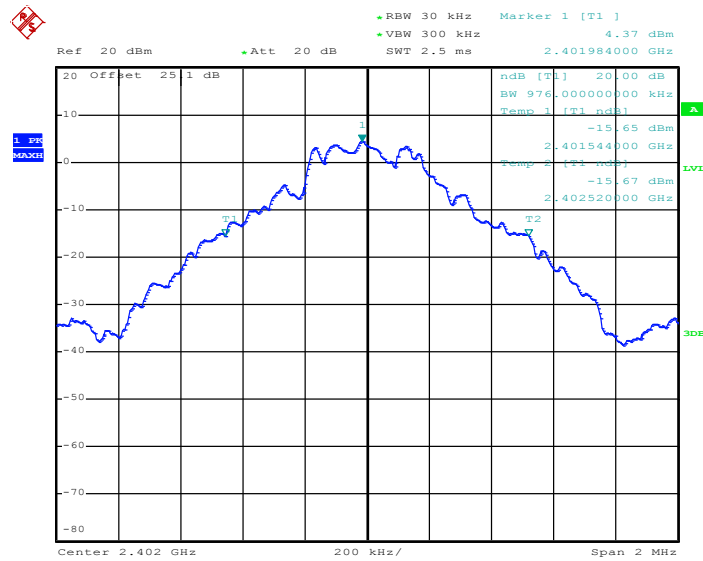

Date: 10.SEP.2014 16:48:54



20 dB Bandwidth Plot on Channel 39

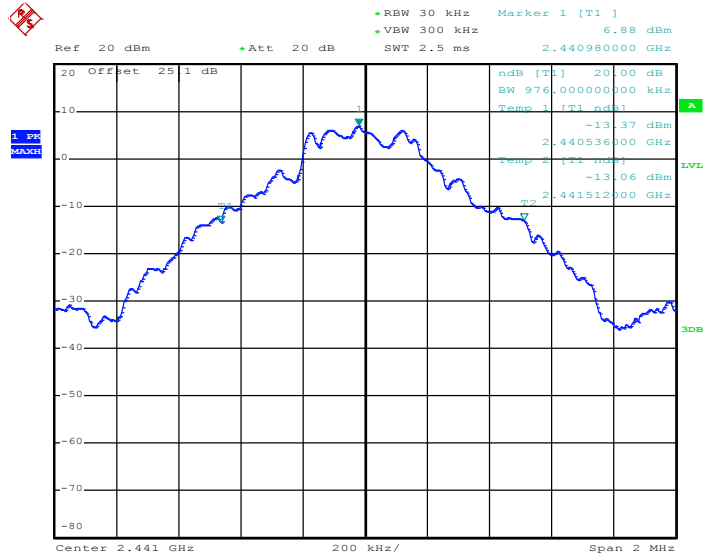

Date: 10.SEP.2014 16:49:37

20 dB Bandwidth Plot on Channel 78

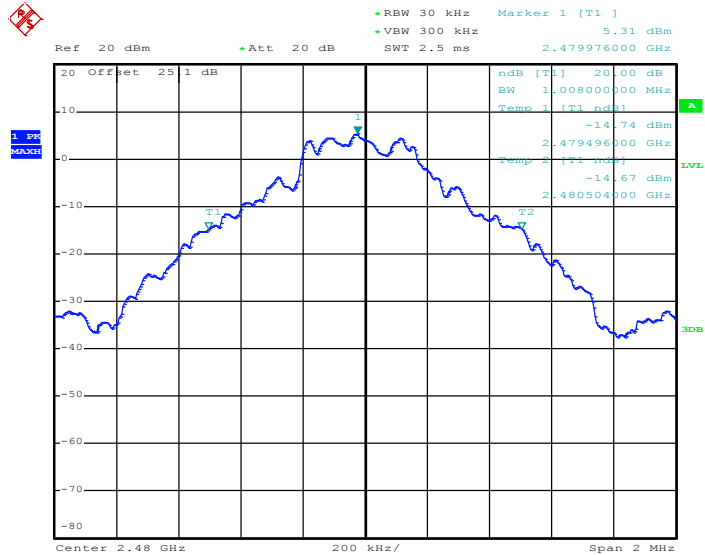

Date: 10.SEP.2014 16:50:07



Test Mode :	2Mbps	Temperature :	24~26°C
Test Engineer :	Alen Tsui	Relative Humidity :	50~53%

Channel	Frequency (MHz)	20dB Bandwidth (MHz)
00	2402	1.356
39	2441	1.356
78	2480	1.356

20 dB Bandwidth Plot on Channel 00

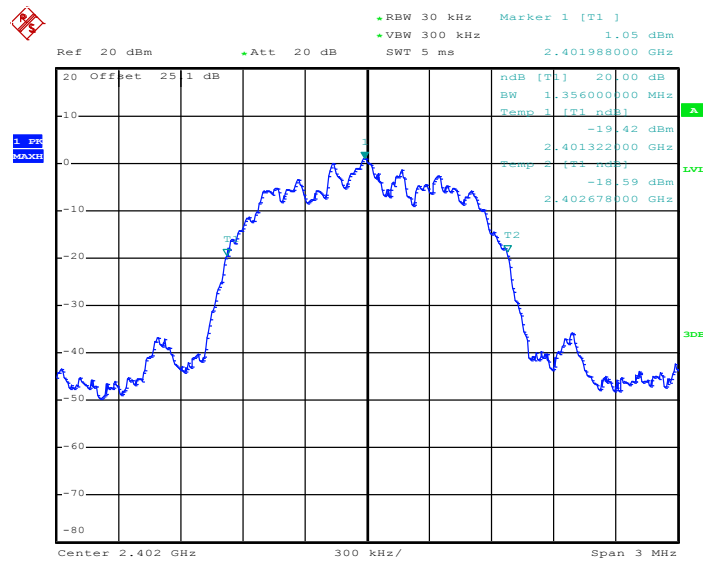

Date: 10.SEP.2014 16:52:35



20 dB Bandwidth Plot on Channel 39

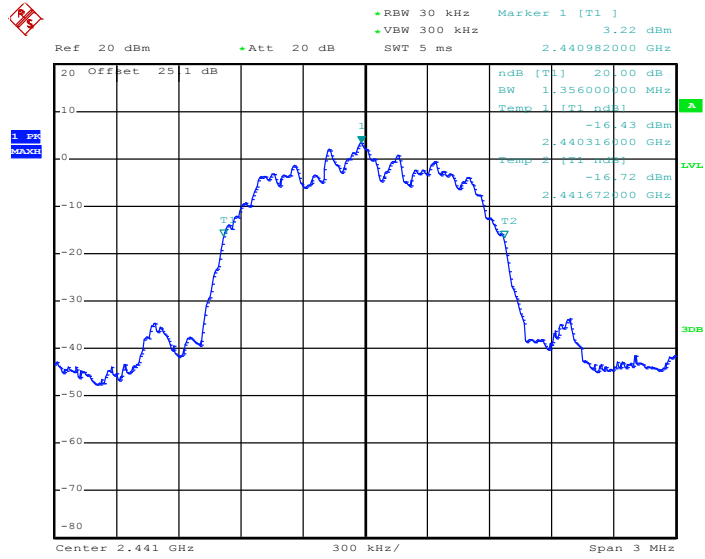

Date: 10.SEP.2014 16:53:06

20 dB Bandwidth Plot on Channel 78

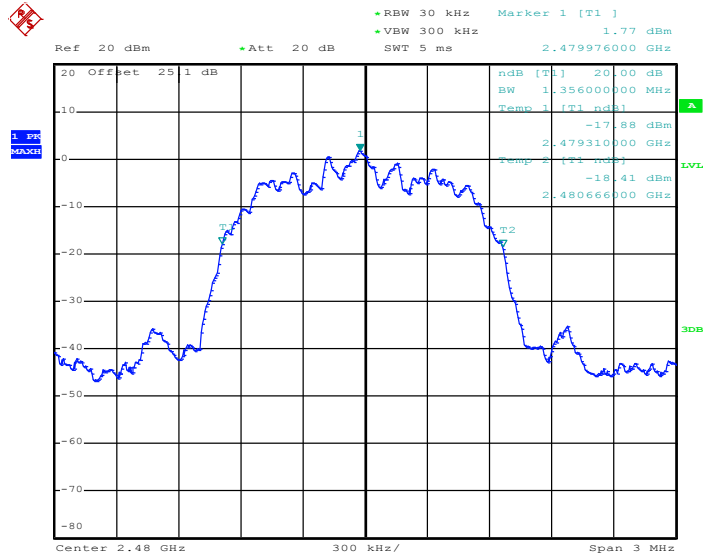

Date: 10.SEP.2014 16:53:56



Test Mode :	3Mbps	Temperature :	24~26°C
Test Engineer :	Alen Tsui	Relative Humidity :	50~53%

Channel	Frequency (MHz)	20dB Bandwidth (MHz)
00	2402	1.320
39	2441	1.320
78	2480	1.320

20 dB Bandwidth Plot on Channel 00

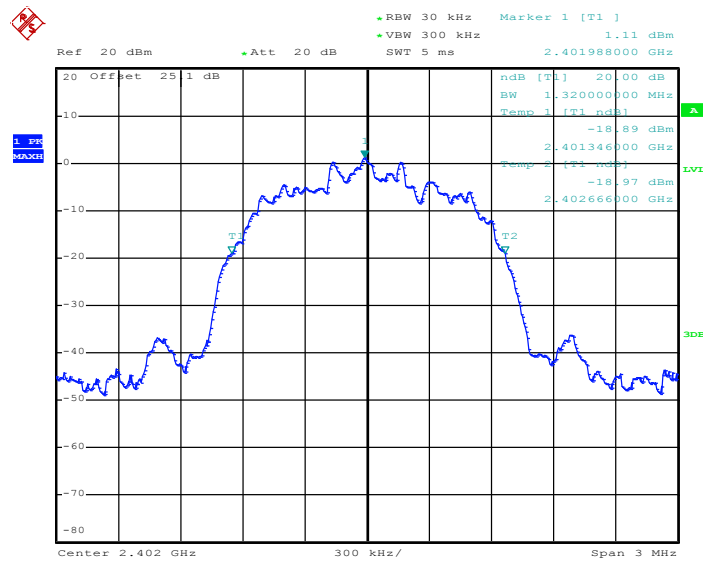

Date: 10.SEP.2014 16:55:05



20 dB Bandwidth Plot on Channel 39

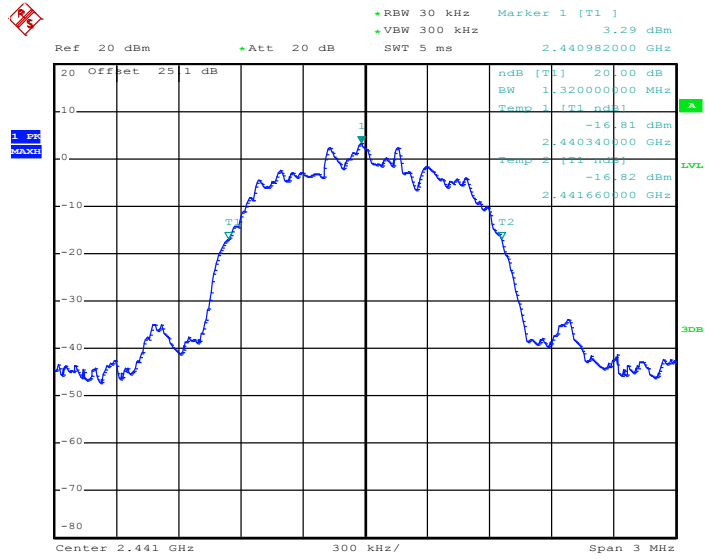

Date: 10.SEP.2014 16:55:45

20 dB Bandwidth Plot on Channel 78

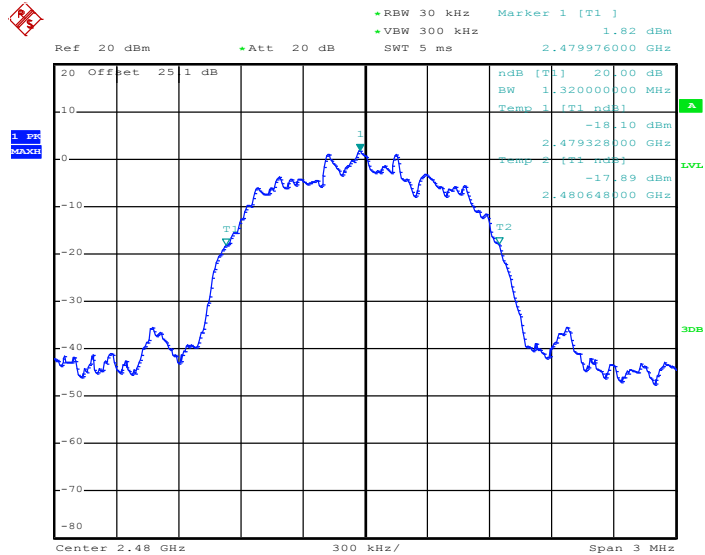

Date: 10.SEP.2014 16:56:59



3.4.6 Test Result of 99% Occupied Bandwidth

Test Mode :	1Mbps	Temperature :	24~26°C
Test Engineer :	Alen Tsui	Relative Humidity :	50~53%

Channel	Frequency (MHz)	99% Occupied Bandwidth (MHz)
00	2402	0.896
39	2441	0.896
78	2480	0.896

99% Occupied Bandwidth Plot on Channel 00

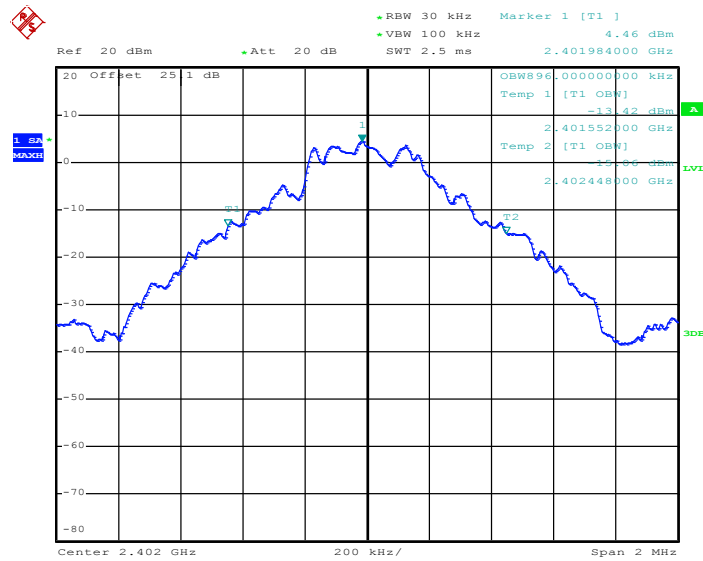

Date: 10.SEP.2014 16:28:51



99% Occupied Bandwidth Plot on Channel 39

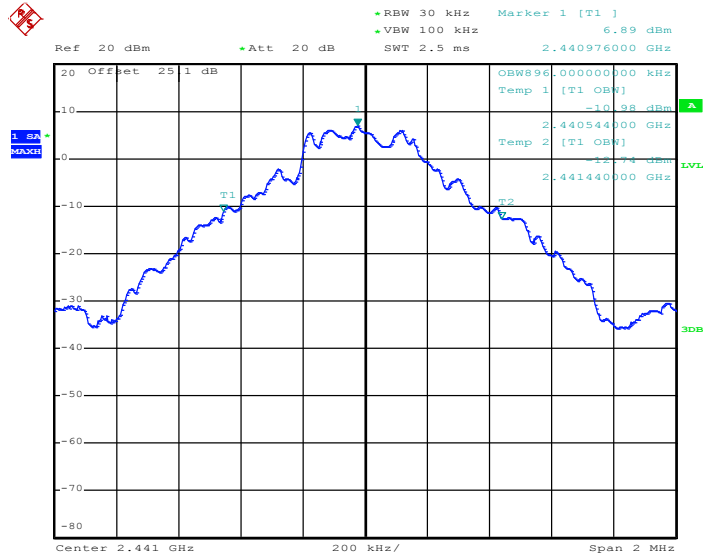

Date: 10.SEP.2014 16:29:22

99% Occupied Bandwidth Plot on Channel 78

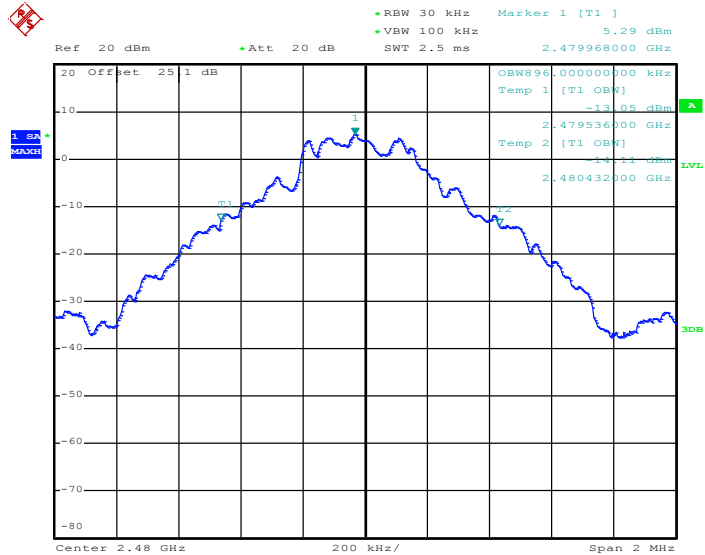

Date: 10.SEP.2014 16:29:54



Test Mode :	2Mbps	Temperature :	24~26°C
Test Engineer :	Alen Tsui	Relative Humidity :	50~53%

Channel	Frequency (MHz)	99% Occupied Bandwidth (MHz)
00	2402	1.192
39	2441	1.204
78	2480	1.208

99% Occupied Bandwidth Plot on Channel 00

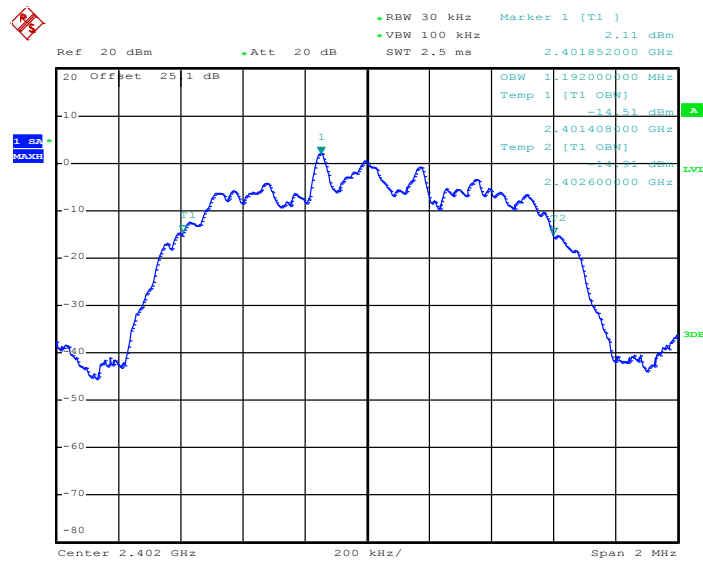

Date: 15.SEP.2014 20:53:47



99% Occupied Bandwidth Plot on Channel 39

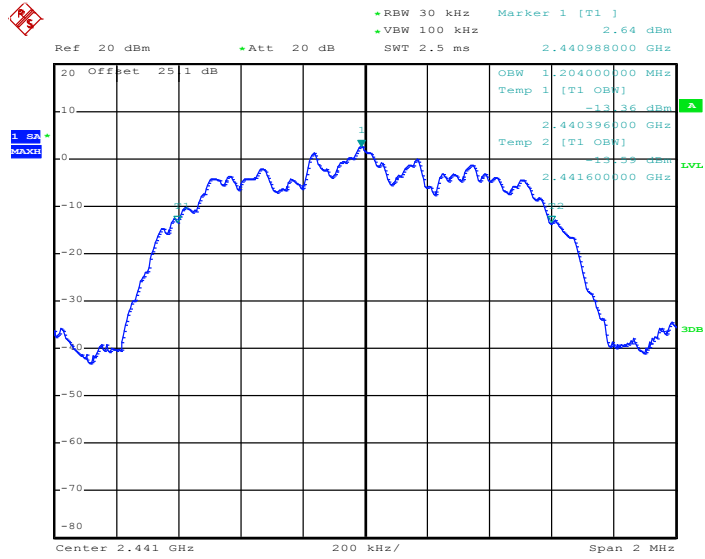

Date: 15.SEP.2014 20:54:37

99% Occupied Bandwidth Plot on Channel 78

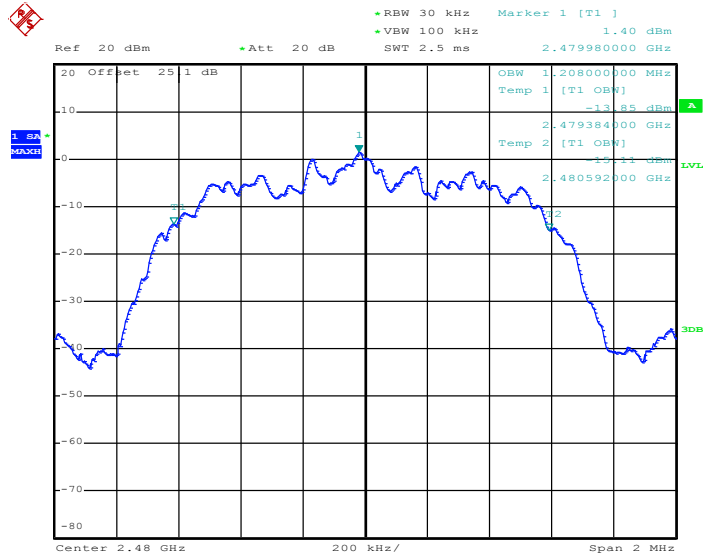

Date: 15.SEP.2014 20:55:18



Test Mode :	3Mbps	Temperature :	24~26°C
Test Engineer :	Alen Tsui	Relative Humidity :	50~53%

Channel	Frequency (MHz)	99% Occupied Bandwidth (MHz)
00	2402	1.180
39	2441	1.180
78	2480	1.184

99% Occupied Bandwidth Plot on Channel 00

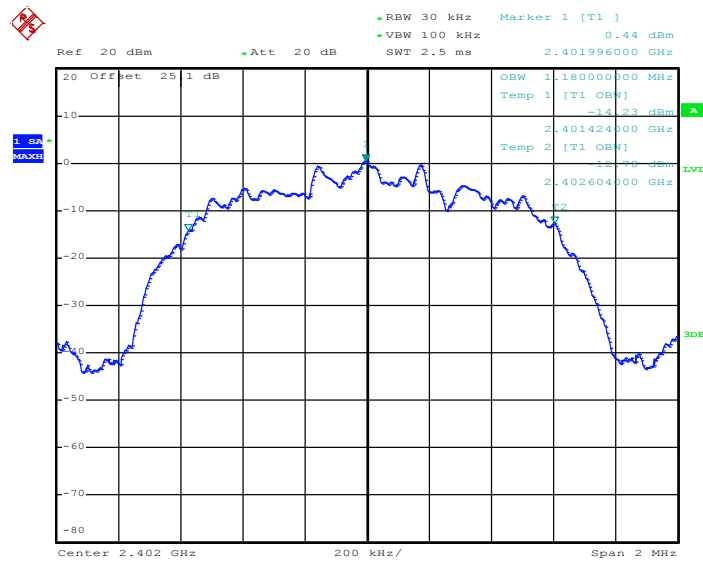

Date: 15.SEP.2014 20:56:24



99% Occupied Bandwidth Plot on Channel 39

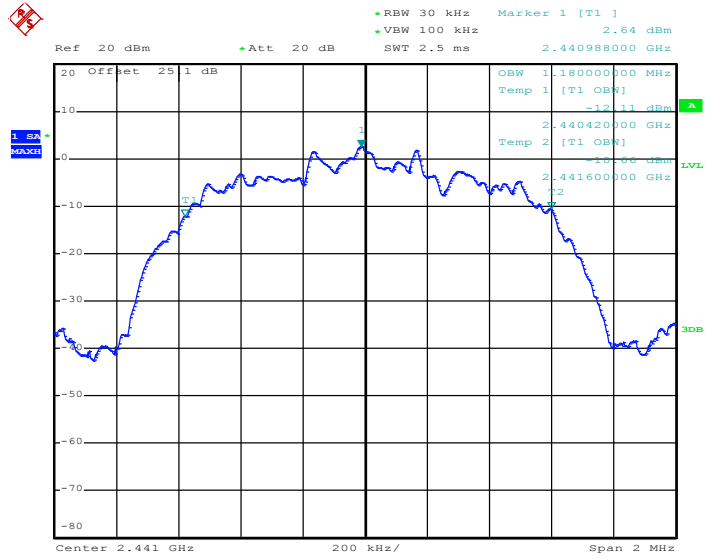

Date: 15.SEP.2014 20:57:10

99% Occupied Bandwidth Plot on Channel 78

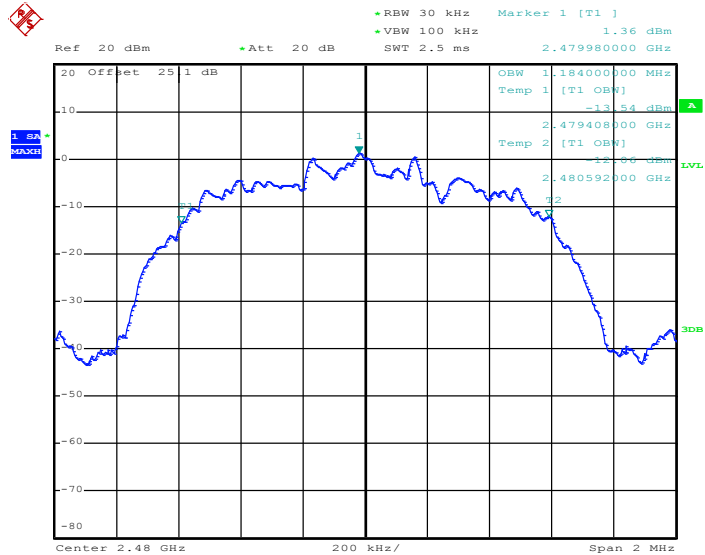

Date: 15.SEP.2014 20:57:49

Note : The occupied channel bandwidth is maintained within the band of operation for all of the modulations.

3.5 Peak Output Power Measurement

3.5.1 Limit of Peak Output Power

Section 15.247 (b) The maximum peak conducted output power of the intentional radiator shall not exceed the following: (1) For frequency hopping systems operating in the 2400-2483.5 MHz band employing at least 75 non-overlapping hopping channels, and all frequency hopping systems in the 5725-5850 MHz band: 1 watt. For all other frequency hopping systems in the 2400-2483.5 MHz band 0.125 watts. The power limit for 1Mbps is 1watt, and for 2Mbps, 3Mbps and AFH are 0.125 watts.

3.5.2 Measuring Instruments

The measuring equipment is listed in the section 4 of this test report.

3.5.3 Test Procedures

1. The testing follows FCC Public Notice DA 00-705 Measurement Guidelines.
2. The RF output of EUT was connected to the power meter by RF cable and attenuator. The path loss was compensated to the results for each measurement.
3. Set to the maximum power setting and enable the EUT transmit continuously.
4. Measure the conducted output power with cable loss and record the results in the test report.
5. Measure and record the results in the test report.

3.5.4 Test Setup

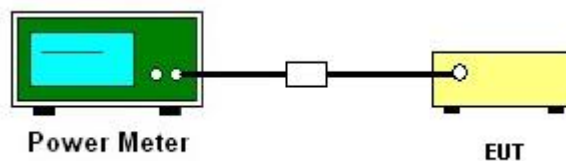



3.5.5 Test Result of Peak Output Power

Test Mode :	1Mbps	Temperature :	24~26°C
Test Engineer :	Alen Tsui	Relative Humidity :	50~53%

Channel	Frequency (MHz)	RF Power (dBm)		
		GFSK	Max. Limits (dBm)	Pass/Fail
		1 Mbps		
00	2402	7.49	20.97	Pass
39	2441	9.85	20.97	Pass
78	2480	8.39	20.97	Pass

Note: For AFH mode using 20 hopping channels, the maximum output power limit is 20.97dBm.

Test Mode :	2Mbps	Temperature :	24~26°C
Test Engineer :	Alen Tsui	Relative Humidity :	50~53%

Channel	Frequency (MHz)	RF Power (dBm)		
		$\pi/4$ -DQPSK	Max. Limits (dBm)	Pass/Fail
		2 Mbps		
00	2402	6.77	20.97	Pass
39	2441	8.91	20.97	Pass
78	2480	7.44	20.97	Pass

Test Mode :	3Mbps	Temperature :	24~26°C
Test Engineer :	Alen Tsui	Relative Humidity :	50~53%

Channel	Frequency (MHz)	RF Power (dBm)		
		8-DPSK	Max. Limits (dBm)	Pass/Fail
		3 Mbps		
00	2402	7.10	20.97	Pass
39	2441	9.23	20.97	Pass
78	2480	7.76	20.97	Pass

3.6 Conducted Band Edges Measurement

3.6.1 Limit of Band Edges

In any 100 kHz bandwidth outside the intentional radiation frequency band, the radio frequency power shall be at least 20 dB below the highest level of the radiated power. In addition, radiated emissions which fall in the restricted bands must also comply with the radiated emission limits.

3.6.2 Measuring Instruments

The measuring equipment is listed in the section 4 of this test report.

3.6.3 Test Procedures

1. The testing follows the guidelines in Band-edge Compliance of RF Conducted Emissions of FCC Public Notice DA 00-705 Measurement Guidelines.
2. Set to the maximum power setting and enable the EUT transmit continuously.
3. Set RBW = 100kHz ($\geq 1\%$ span=10MHz), VBW = 300kHz (\geq RBW). Band edge emissions must be at least 20 dB down from the highest emission level within the authorized band as measured with a 100kHz RBW. The attenuation shall be 30 dB instead of 20 dB when RMS conducted output power procedure is used.
4. Enable hopping function of the EUT and then repeat step 2. and 3.
5. Measure and record the results in the test report.

3.6.4 Test Setup

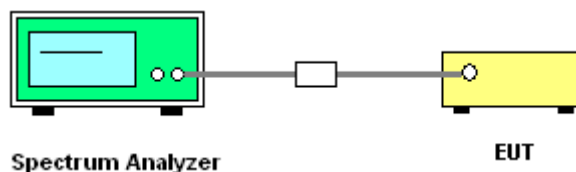



3.6.5 Test Result of Conducted Band Edges

Test Mode :	1Mbps	Temperature :	24~26°C
Test Channel :	00 and 78	Relative Humidity :	50~53%
		Test Engineer :	Alen Tsui

Low Band Edge Plot on Channel 00

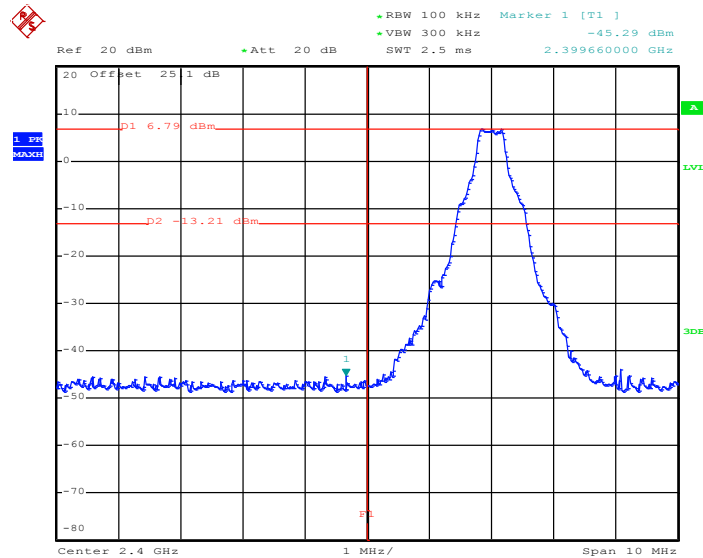

Date: 10.SEP.2014 16:27:26

High Band Edge Plot on Channel 78

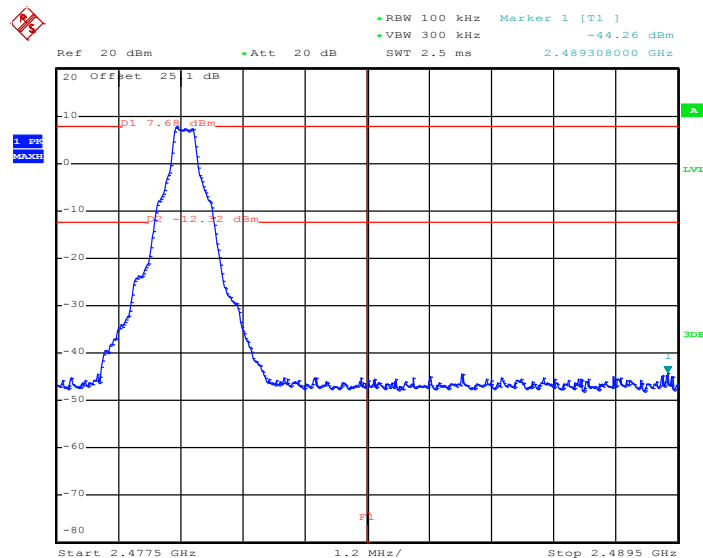

Date: 10.SEP.2014 16:28:18



Test Mode :	2Mbps	Temperature :	24~26°C
Test Channel :	00 and 78	Relative Humidity :	50~53%
		Test Engineer :	Alen Tsui

Low Band Edge Plot on Channel 00

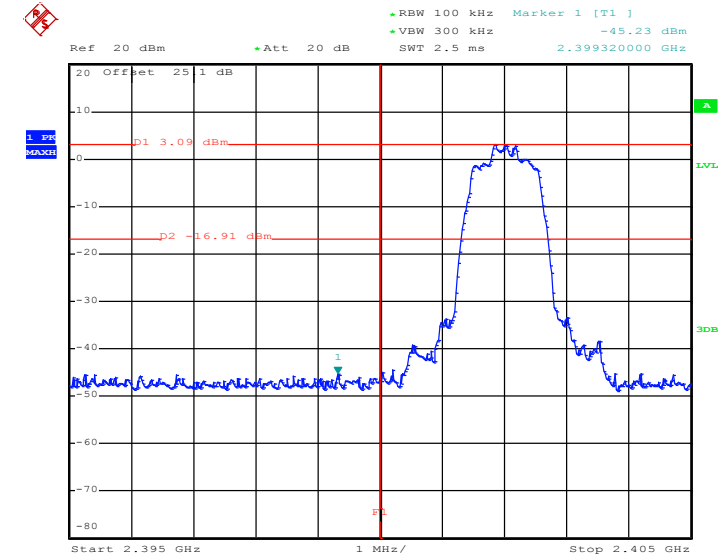

Date: 15.SEP.2014 20:38:00

High Band Edge Plot on Channel 78

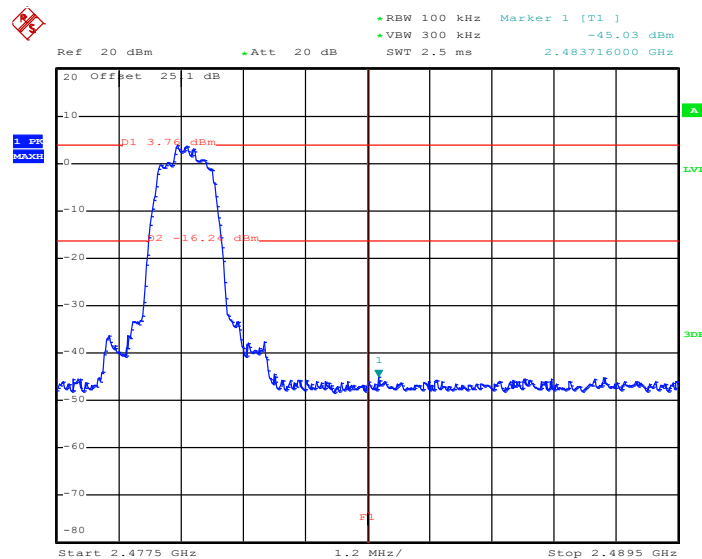

Date: 15.SEP.2014 20:38:24



Test Mode :	3Mbps	Temperature :	24~26°C
Test Channel :	00 and 78	Relative Humidity :	50~53%
		Test Engineer :	Alen Tsui

Low Band Edge Plot on Channel 00

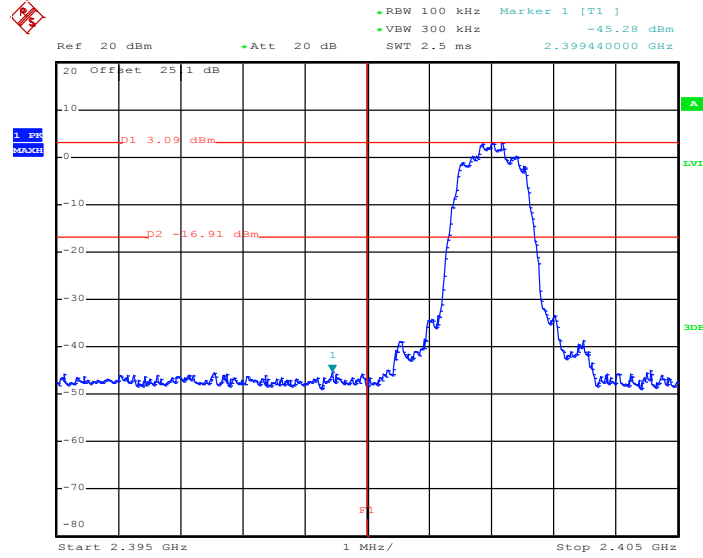

Date: 15.SEP.2014 20:38:55

High Band Edge Plot on Channel 78

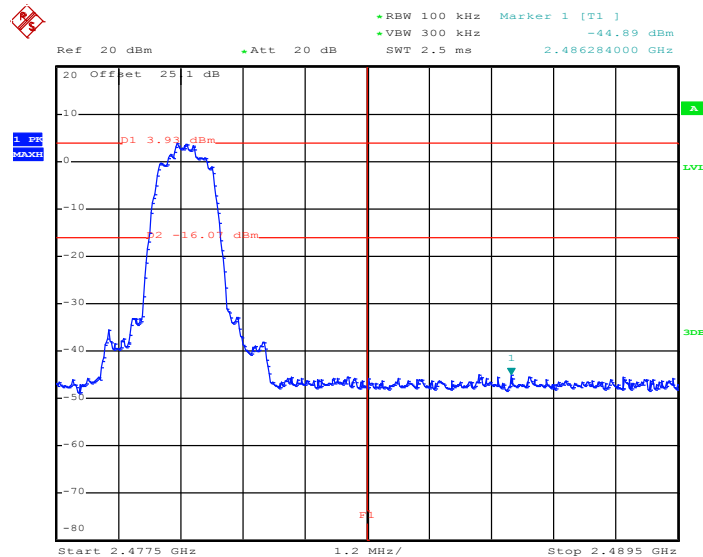

Date: 15.SEP.2014 20:39:20



3.6.6 Test Result of Conducted Hopping Mode Band Edges

Test Mode :	1Mbps	Temperature :	24~26°C
Test Engineer :	Alen Tsui	Relative Humidity :	50~53%

1Mbps Hopping Mode Low Band Edge Plot

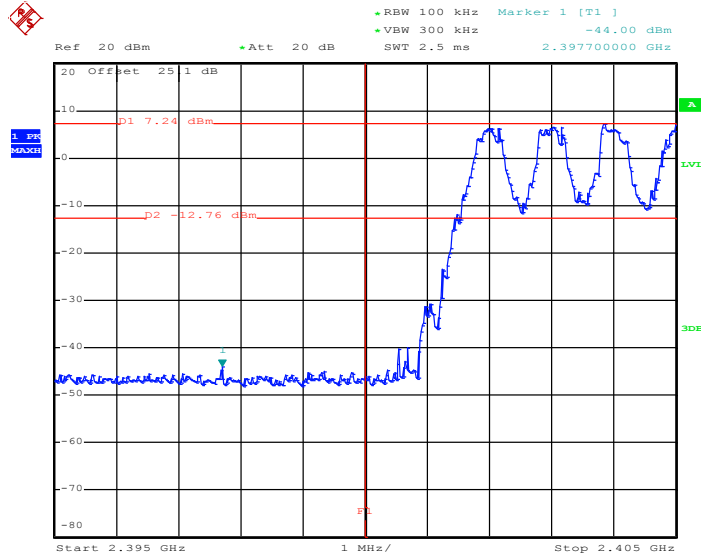

Date: 10.SEP.2014 18:16:22

1Mbps Hopping Mode High Band Edge Plot

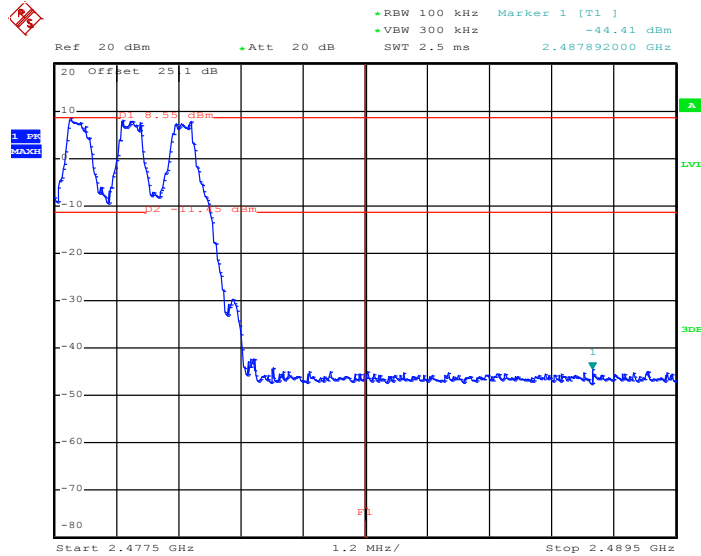

Date: 10.SEP.2014 18:14:51



Test Mode :	2Mbps	Temperature :	24~26°C
Test Engineer :	Alen Tsui	Relative Humidity :	50~53%

2Mbps Hopping Mode Low Band Edge Plot

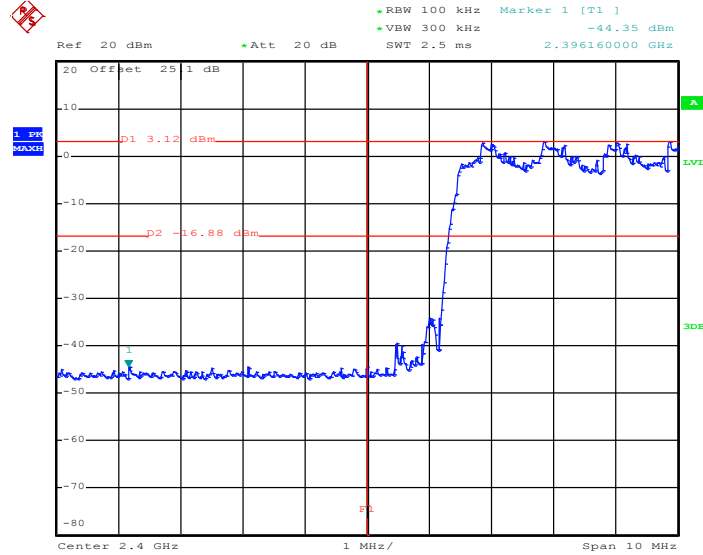

Date: 15.SEP.2014 20:15:30

2Mbps Hopping Mode High Band Edge Plot

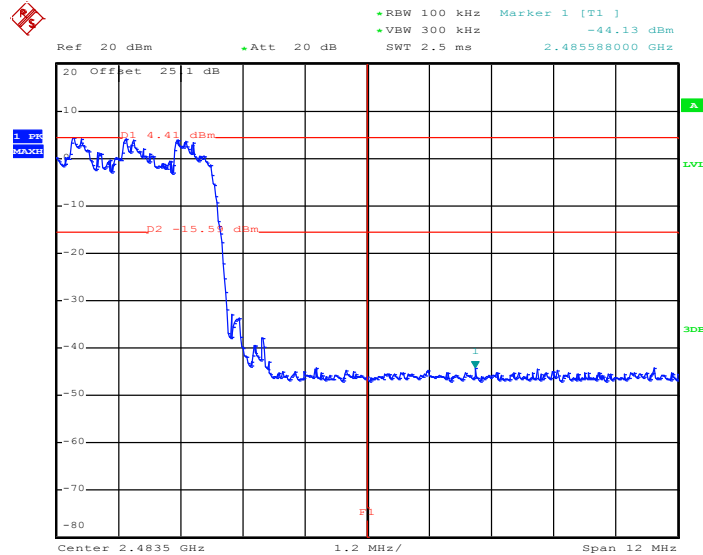

Date: 15.SEP.2014 20:17:52



Test Mode :	3Mbps	Temperature :	24~26°C
Test Engineer :	Alen Tsui	Relative Humidity :	50~53%

3Mbps Hopping Mode Low Band Edge Plot

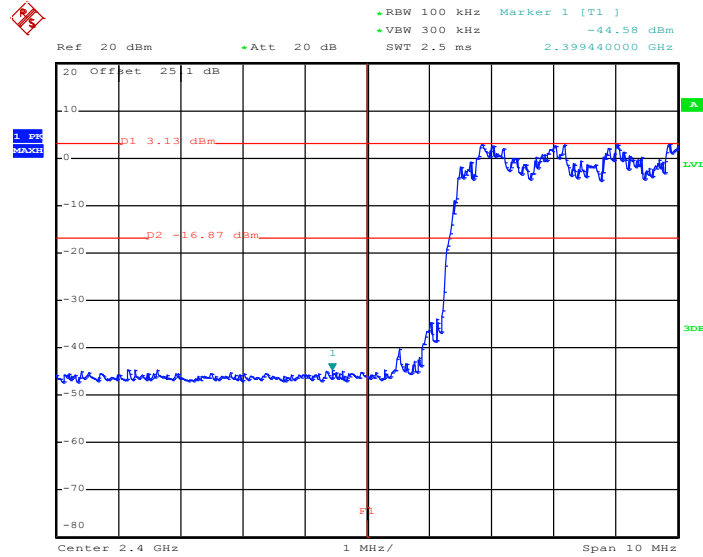

Date: 15.SEP.2014 20:20:56

3Mbps Hopping Mode High Band Edge Plot

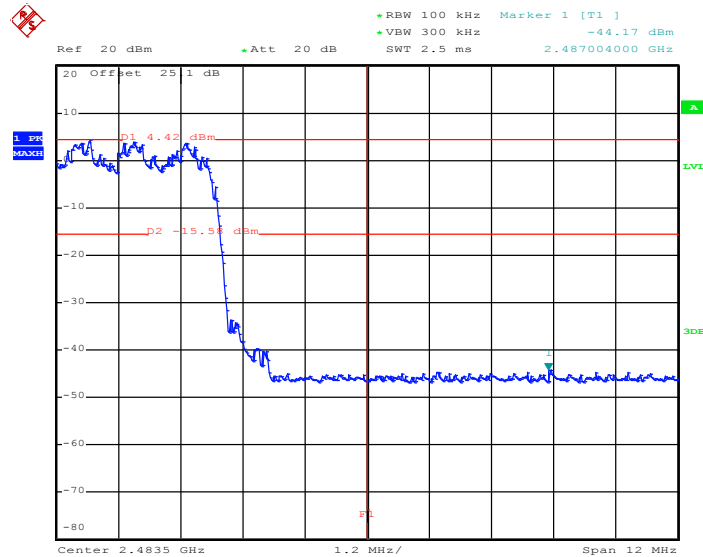

Date: 15.SEP.2014 20:23:25

3.7 Conducted Spurious Emission Measurement

3.7.1 Limit of Spurious Emission Measurement

In any 100 kHz bandwidth outside the intentional radiation frequency band, the radio frequency power shall be at least 20 dB below the highest level of the radiated power. In addition, radiated emissions which fall in the restricted bands must also comply with the radiated emission limits.

3.7.2 Measuring Instruments

The measuring equipment is listed in the section 4 of this test report.

3.7.3 Test Procedure

1. The testing follows the guidelines in Spurious RF Conducted Emissions of FCC Public Notice DA 00-705 Measurement Guidelines
2. The RF output of EUT was connected to the spectrum analyzer by RF cable and attenuator. The path loss was compensated to the results for each measurement.
3. Set to the maximum power setting and enable the EUT transmit continuously.
4. Set RBW = 100 kHz, VBW = 300kHz, scan up through 10th harmonic. All harmonics / spurs must be at least 20 dB down from the highest emission level within the authorized band as measured with a 100 kHz RBW.
5. Measure and record the results in the test report.
6. The RF fundamental frequency should be excluded against the limit line in the operating frequency band.

3.7.4 Test Setup

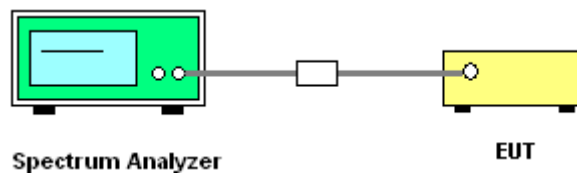



3.7.5 Test Result of Conducted Spurious Emission

Test Mode :	1Mbps	Temperature :	24~26°C
Test Channel :	00	Relative Humidity :	50~53%
		Test Engineer :	Alen Tsui

1Mbps CSE Plot on Ch 00 between 30MHz ~ 3 GHz

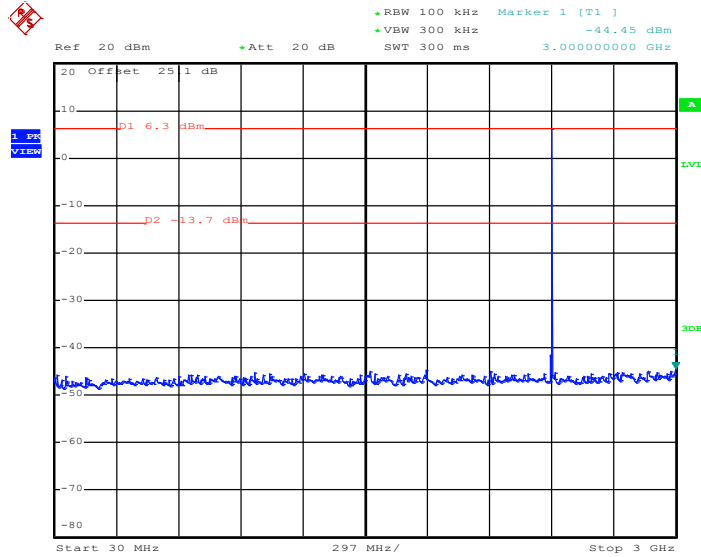

Date: 10.SEP.2014 16:42:22

1Mbps CSE Plot on Ch 00 between 2 GHz ~ 25 GHz

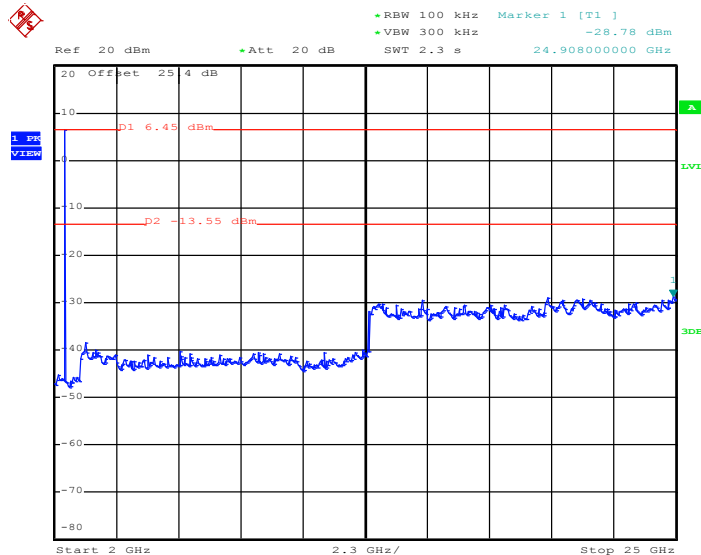

Date: 10.SEP.2014 16:42:43



Test Mode :	1Mbps	Temperature :	24~26°C
Test Channel :	39	Relative Humidity :	50~53%
		Test Engineer :	Alen Tsui

1Mbps CSE Plot on Ch 39 between 30MHz ~ 3 GHz

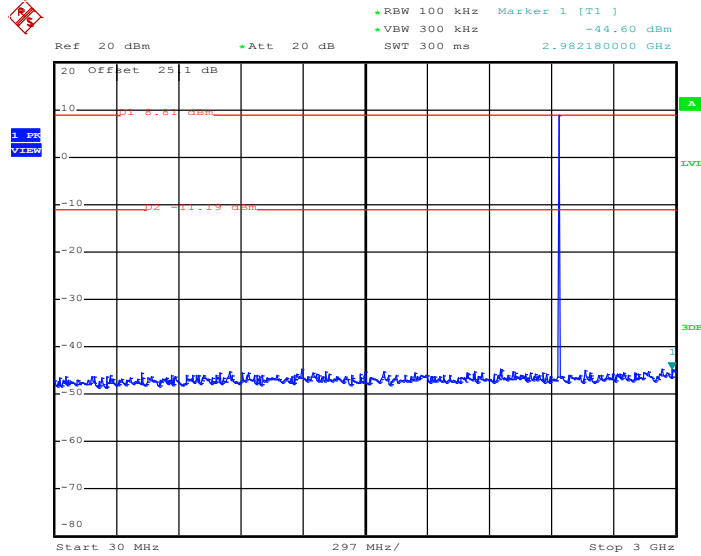

Date: 10.SEP.2014 16:43:25

1Mbps CSE Plot on Ch 39 between 2 GHz ~ 25 GHz

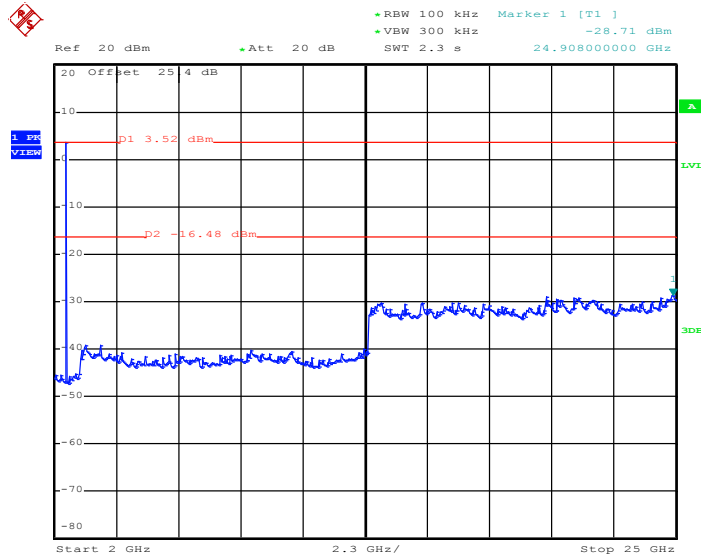

Date: 10.SEP.2014 16:43:47



Test Mode :	1Mbps	Temperature :	24~26°C
Test Channel :	78	Relative Humidity :	50~53%
		Test Engineer :	Alen Tsui

1Mbps CSE Plot on Ch 78 between 30MHz ~ 3 GHz

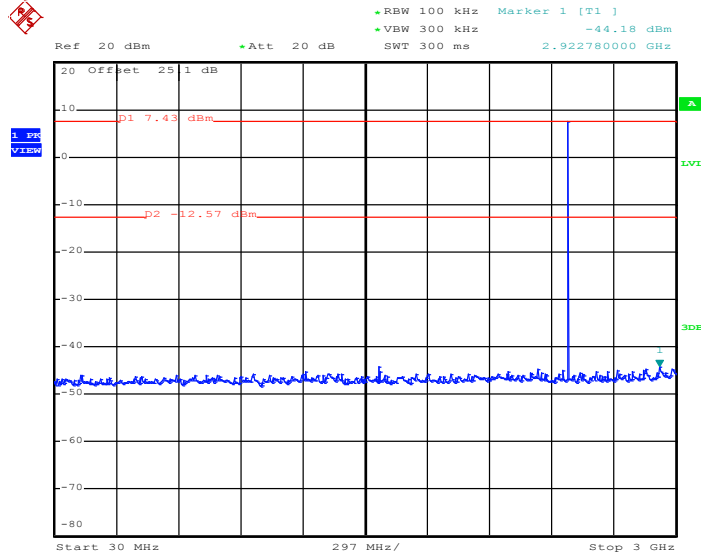

Date: 10.SEP.2014 16:44:30

1Mbps CSE Plot on Ch 78 between 2 GHz ~ 25 GHz

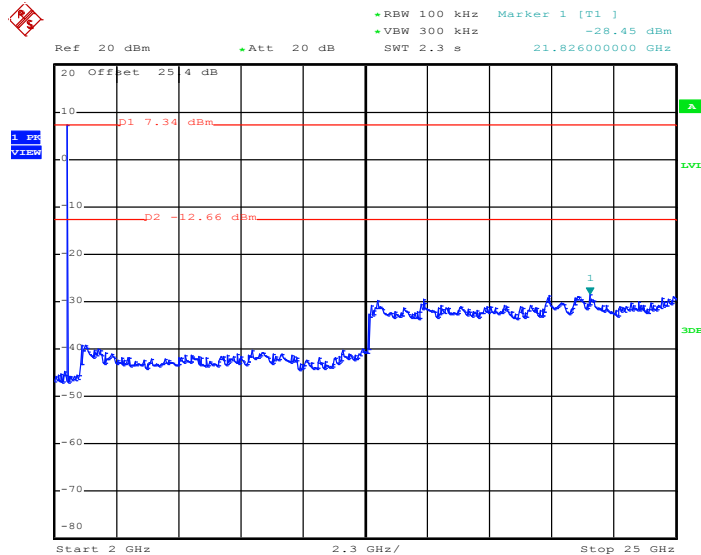

Date: 10.SEP.2014 16:44:52



Test Mode :	2Mbps	Temperature :	24~26°C
Test Channel :	00	Relative Humidity :	50~53%
		Test Engineer :	Alen Tsui

2Mbps CSE Plot on Ch 00 between 30MHz ~ 3 GHz

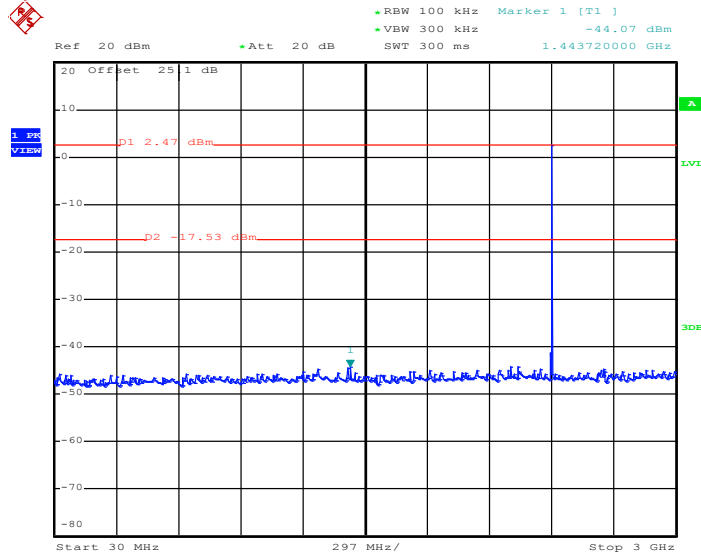

Date: 15.SEP.2014 20:58:46

2Mbps CSE Plot on Ch 00 between 2 GHz ~ 25 GHz

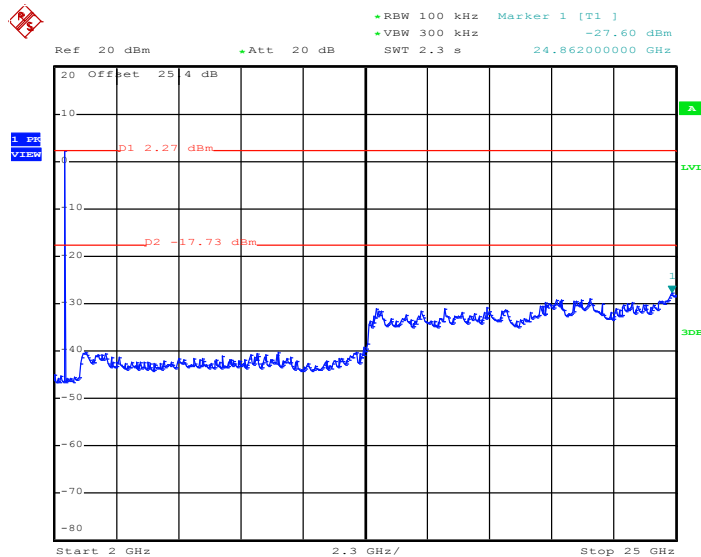

Date: 15.SEP.2014 20:59:08



Test Mode :	2Mbps	Temperature :	24~26°C
Test Channel :	39	Relative Humidity :	50~53%
		Test Engineer :	Alen Tsui

2Mbps CSE Plot on Ch 39 between 30MHz ~ 3 GHz

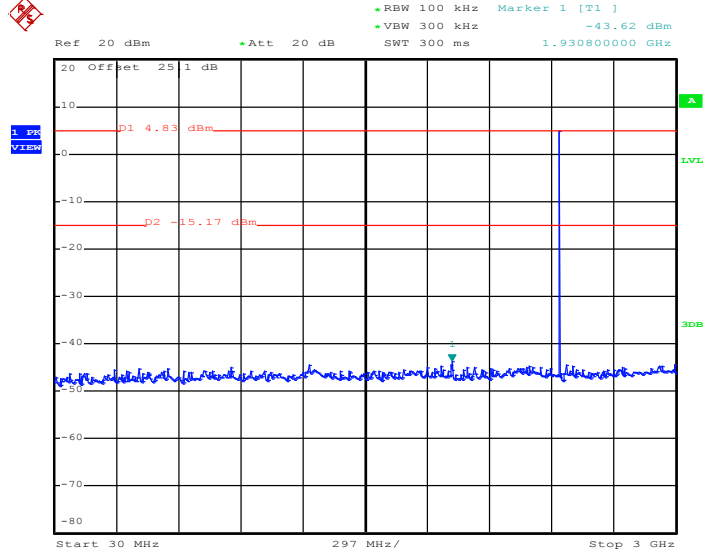

Date: 15.SEP.2014 20:59:49

2Mbps CSE Plot on Ch 39 between 2 GHz ~ 25 GHz

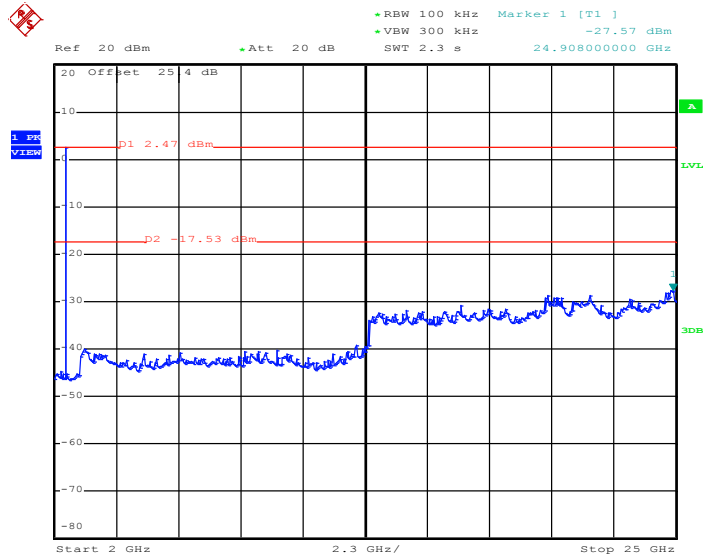

Date: 15.SEP.2014 21:00:10



Test Mode :	2Mbps	Temperature :	24~26°C
Test Channel :	78	Relative Humidity :	50~53%
		Test Engineer :	Alen Tsui

2Mbps CSE Plot on Ch 78 between 30MHz ~ 3 GHz

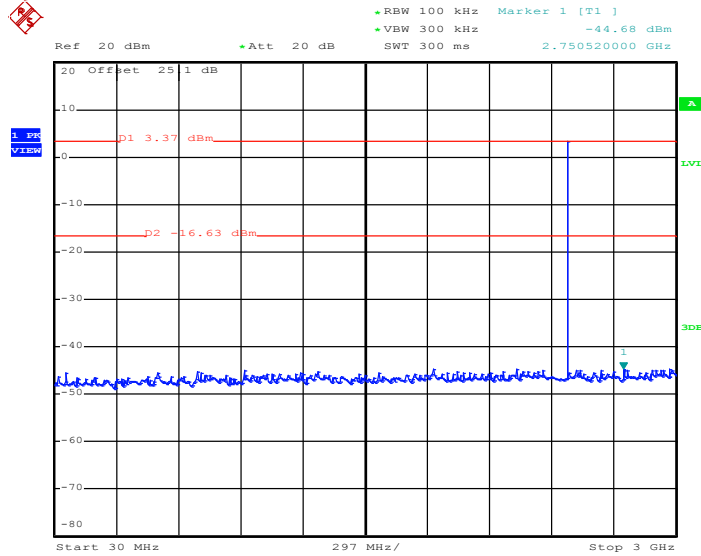

Date: 15.SEP.2014 21:00:57

2Mbps CSE Plot on Ch 78 between 2 GHz ~ 25 GHz

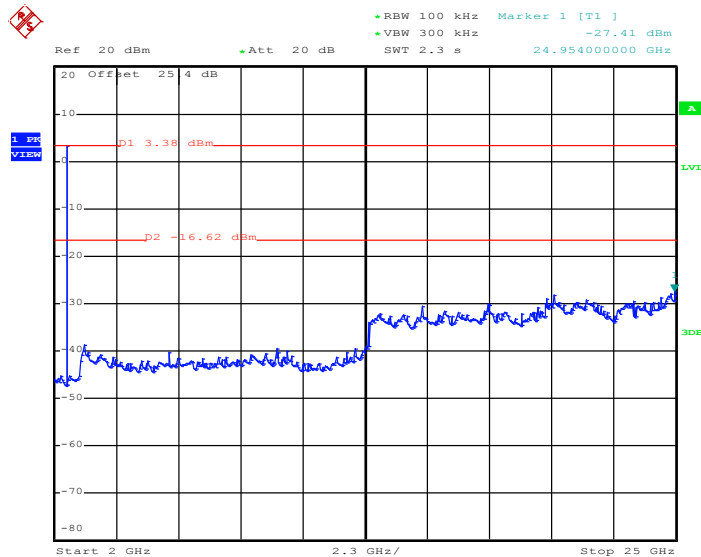

Date: 15.SEP.2014 21:01:19



Test Mode :	3Mbps	Temperature :	24~26°C
Test Channel :	00	Relative Humidity :	50~53%
		Test Engineer :	Alen Tsui

3Mbps CSE Plot on Ch 00 between 30MHz ~ 3 GHz

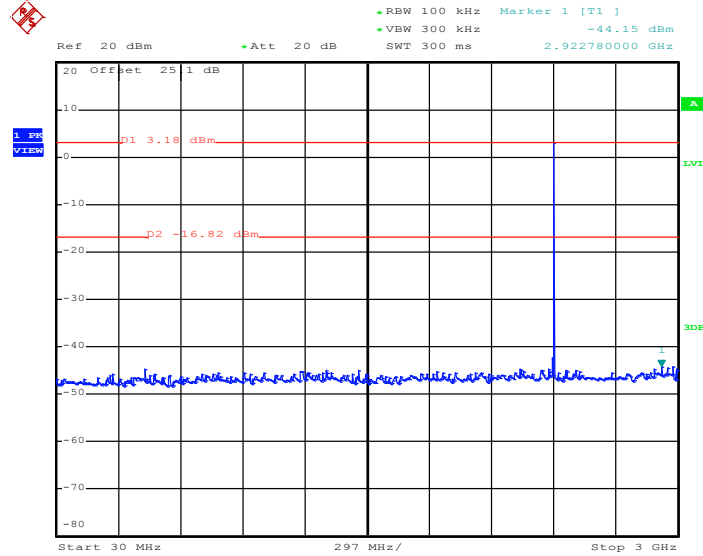

Date: 15.SEP.2014 21:03:40

3Mbps CSE Plot on Ch 00 between 2 GHz ~ 25 GHz

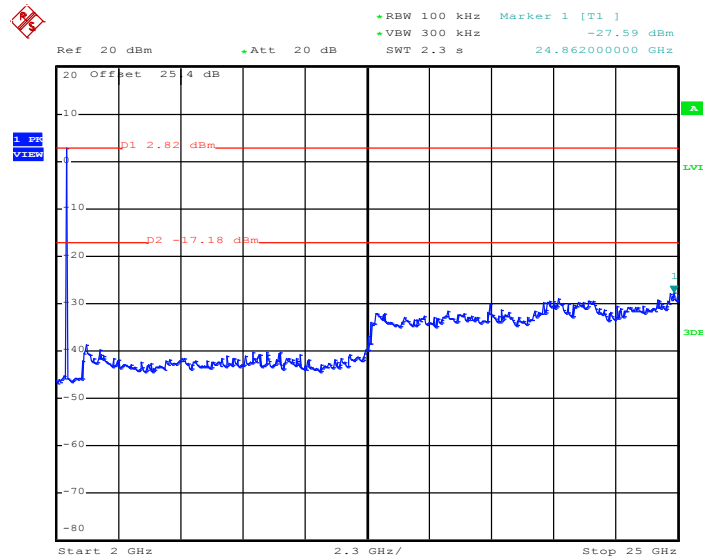

Date: 15.SEP.2014 21:04:01



Test Mode :	3Mbps	Temperature :	24~26°C
Test Channel :	39	Relative Humidity :	50~53%
		Test Engineer :	Alen Tsui

3Mbps CSE Plot on Ch 39 between 30MHz ~ 3 GHz

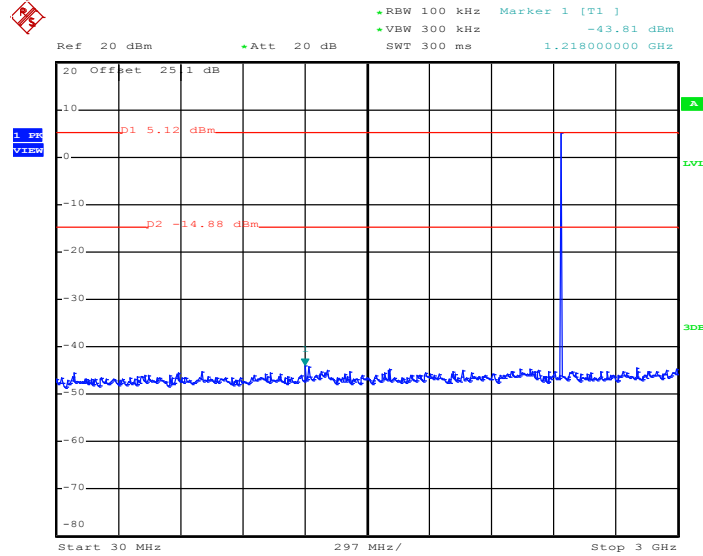

Date: 15.SEP.2014 21:05:47

3Mbps CSE Plot on Ch 39 between 2 GHz ~ 25 GHz

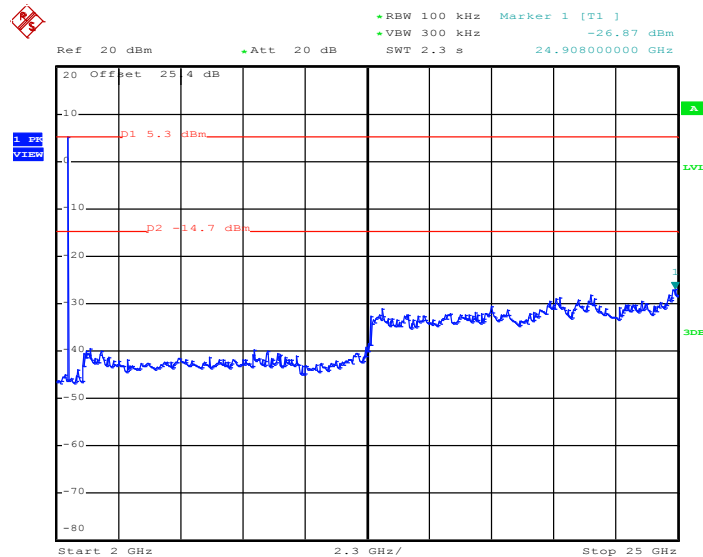

Date: 15.SEP.2014 21:06:08



Test Mode :	3Mbps	Temperature :	24~26°C
Test Channel :	78	Relative Humidity :	50~53%
		Test Engineer :	Alen Tsui

3Mbps CSE Plot on Ch 78 between 30MHz ~ 3 GHz

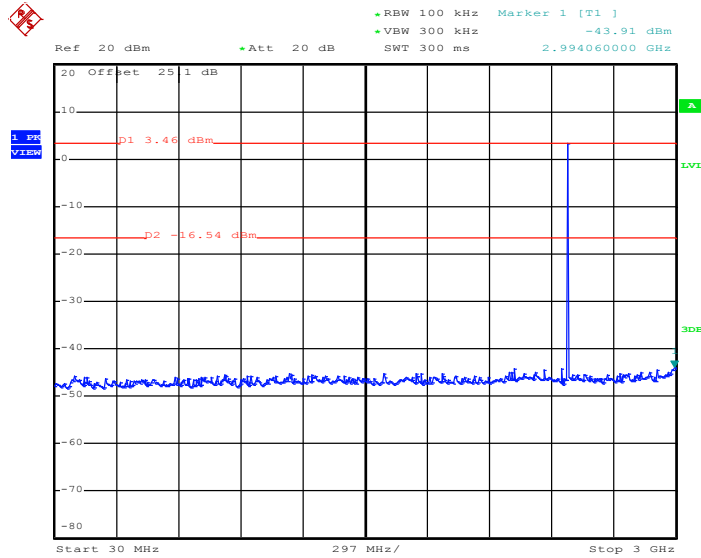

Date: 15.SEP.2014 21:06:48

3Mbps CSE Plot on Ch 78 between 2 GHz ~ 25 GHz

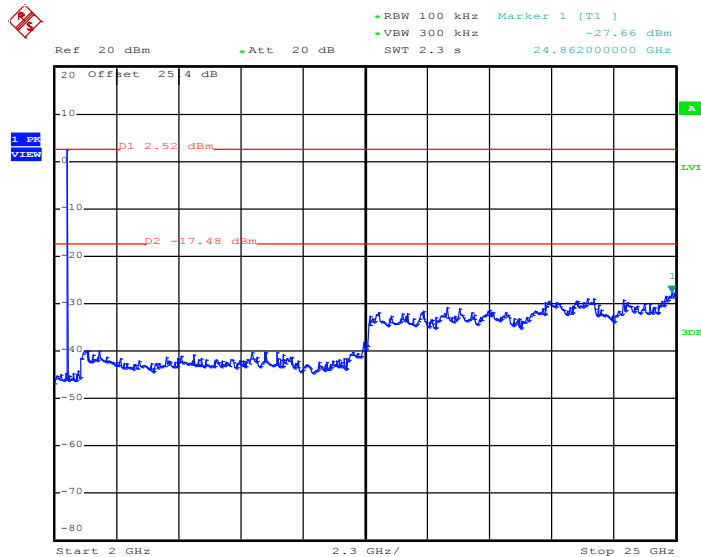

Date: 15.SEP.2014 21:07:10



3.8 Radiated Band Edges and Spurious Emission Measurement

3.8.1 Limit of Radiated Band Edges and Spurious Emission

In any 100 kHz bandwidth outside the intentional radiator frequency band, all harmonics/spurious must be at least 20 dB below the highest emission level within the authorized band. In addition, radiated emissions which fall in the restricted bands must also comply with the FCC section 15.209 limits as below.

Note: Wireless charger configuration was evaluated.

Frequency (MHz)	Field Strength (microvolts/meter)	Measurement Distance (meters)
0.009 – 0.490	2400/F(kHz)	300
0.490 – 1.705	24000/F(kHz)	30
1.705 – 30.0	30	30
30 – 88	100	3
88 – 216	150	3
216 - 960	200	3
Above 960	500	3

3.8.2 Measuring Instruments

The measuring equipment is listed in the section 4 of this test report.



3.8.3 Test Procedures

1. The testing follows the guidelines in Spurious Radiated Emissions of FCC Public Notice DA 00-705 Measurement Guidelines.
2. The EUT was placed on a turntable with 0.8 meter above ground.
3. The EUT was set 3 meters from the interference receiving antenna, which was mounted on the top of a variable height antenna tower.
4. For each suspected emission, the EUT was arranged to its worst case and then tune the Antenna tower (from 1 m to 4 m) and turntable (from 0 degree to 360 degrees) to find the maximum reading. A pre-amp and a high pass filter are used for the test in order to get better signal level to comply with the guidelines.
5. Set to the maximum power setting and enable the EUT transmit continuously.
6. Use the following spectrum analyzer settings:
 - (1) Span shall wide enough to fully capture the emission being measured;
 - (2) Set RBW=100 kHz for $f < 1$ GHz, RBW=1MHz for $f > 1$ GHz ; VBW \geq RBW; Sweep = auto; Detector function = peak; Trace = max hold for peak
 - (3) For average measurement: use duty cycle correction factor method per 15.35(c).
Duty cycle = On time/100 milliseconds
On time = $N_1 * L_1 + N_2 * L_2 + \dots + N_{n-1} * L_{n-1} + N_n * L_n$
Where N_1 is number of type 1 pulses, L_1 is length of type 1 pulses, etc.
Average Emission Level = Peak Emission Level + $20 * \log(\text{Duty cycle})$
7. Corrected Reading: Antenna Factor + Cable Loss + Read Level - Preamp Factor = Level

Note: The average levels were calculated from the peak level corrected with duty cycle correction factor (-24.73dB) derived from $20 \log(\text{dwell time}/100\text{ms})$. This correction is only for signals that hop with the fundamental signal, such as band-edge and harmonic. Other spurious signals that are independent of the hopping signal would not use this correction.

3.8.4 Test Setup

For radiated emissions below 30MHz

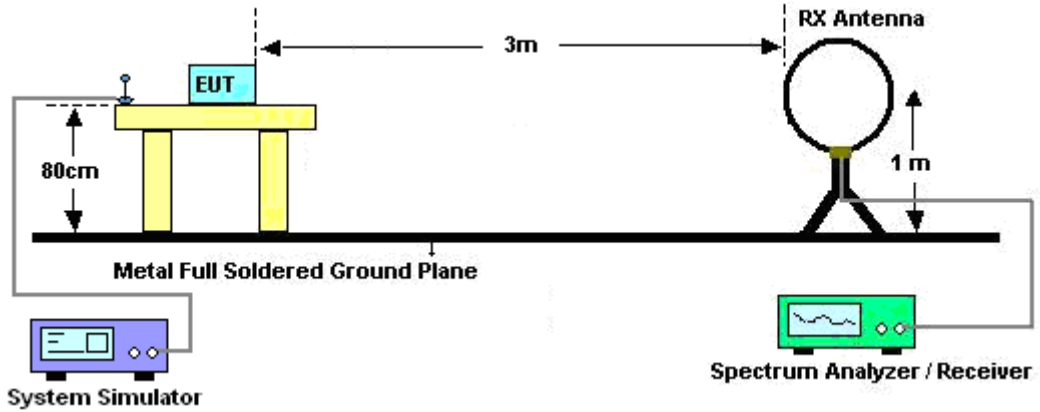

For radiated emissions from 30MHz to 1GHz

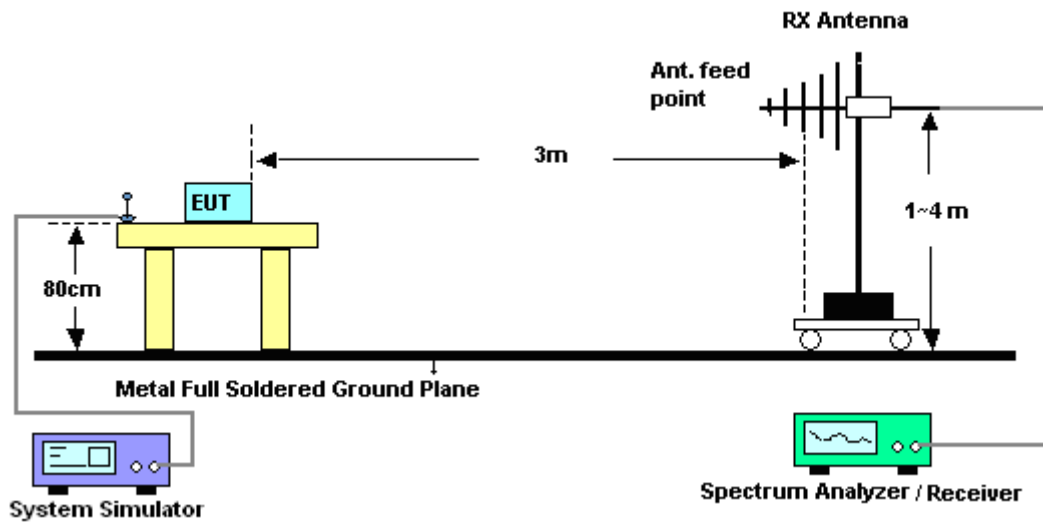

For radiated emissions above 1GHz

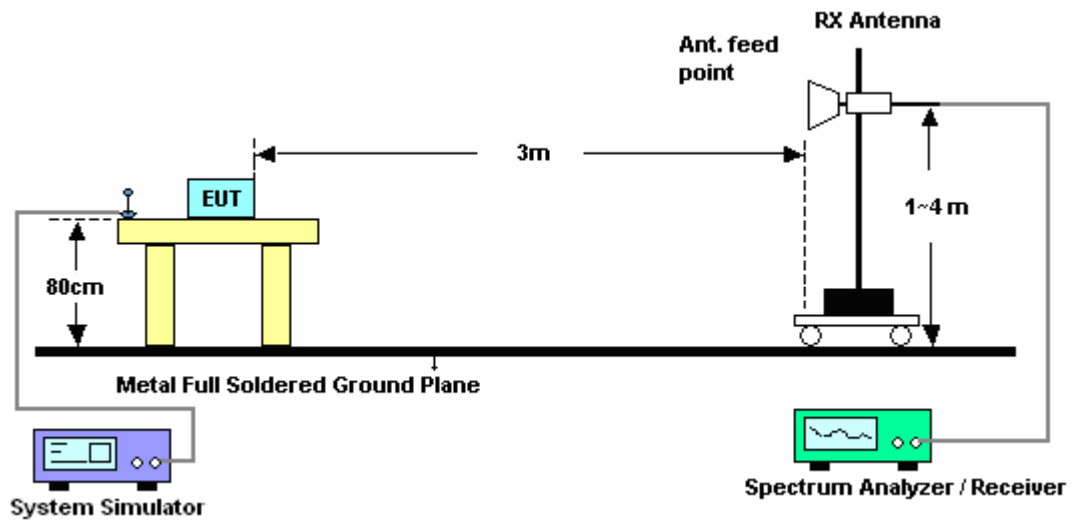



3.8.5 Duty cycle correction factor for average measurement

DH5 on time (One Pulse) Plot on Channel 39

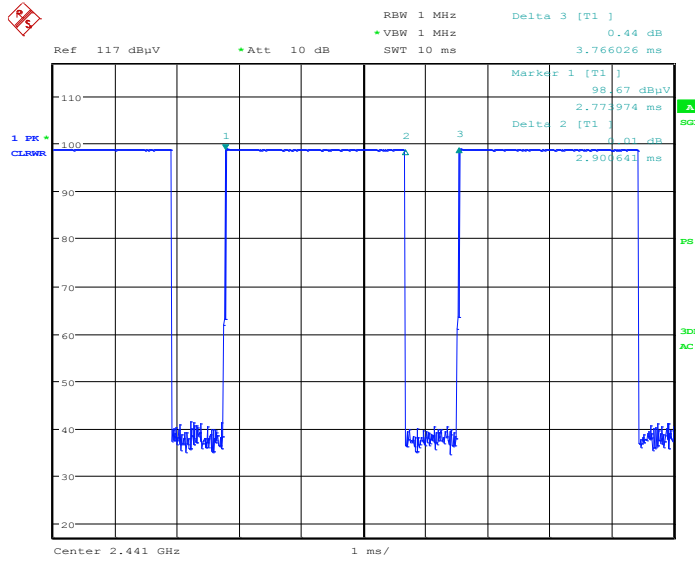

Date: 23.AUG.2014 13:10:55

DH5 on time (Count Pulses) Plot on Channel 39

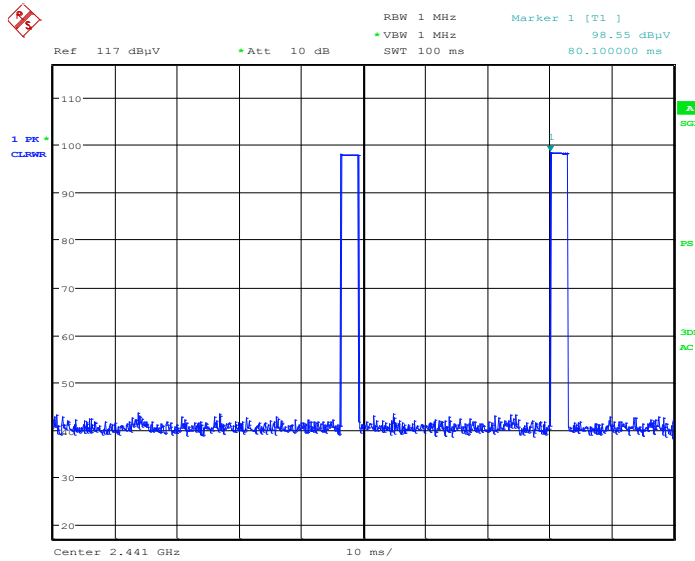

Date: 23.AUG.2014 13:13:13

Note:

1. Worst case Duty cycle = on time/100 milliseconds = $2 * 2.90 / 100 = 5.80 \%$
2. Worst case Duty cycle correction factor = $20 * \log(\text{Duty cycle}) = -24.73 \text{ dB}$
3. DH5 has the highest duty cycle worst case and is reported.



Duty Cycle Correction Factor Consideration for AFH mode:

Bluetooth normal hopping rate is 1600Hz and reduced to 800Hz in AFH mode; due to the reduced number of hopping frequencies, with the same packet configuration the dwell time in each channel frequency within 100msec period is longer in AFH mode than normal mode.

In AFH mode, the minimum hopping frequencies are 20, to get the longest dwell time DH5 packet is observed; the period to have DH5 packet completing one hopping sequence is

$$2.90 \text{ ms} \times 20 \text{ channels} = 58.0 \text{ ms}$$

There cannot be 2 complete hopping sequences within 100ms period, considering the random hopping behavior, maximum 2 hops can be possibly observed within the period. $[100\text{ms} / 57.6\text{ms}] = 2 \text{ hops}$

Thus, the maximum possible ON time:

$$2.90 \text{ ms} \times 2 = 5.80 \text{ ms}$$

Worst case Duty Cycle Correction factor, which is derived from the maximum possible ON time,

$$20 \times \log(5.80 \text{ ms}/100\text{ms}) = -24.73 \text{ dB}$$

3.8.6 Test Result

Please refer to appendix A as below.



3.9 AC Conducted Emission Measurement

3.9.1 Limit of AC Conducted Emission

For equipment that is designed to be connected to the public utility (AC) power line, the radio frequency voltage that is conducted back onto the AC power line on any frequency or frequencies within the band 150 kHz to 30 MHz shall not exceed the limits in the following table.

Frequency of emission (MHz)	Conducted limit (dBµV)	
	Quasi-peak	Average
0.15-0.5	66 to 56*	56 to 46*
0.5-5	56	46
5-30	60	50

*Decreases with the logarithm of the frequency.

3.9.2 Measuring Instruments

The measuring equipment is listed in the section 4 of this test report.

3.9.3 Test Procedures

1. The EUT was placed 0.4 meter from the conducting wall of the shielding room was kept at least 80 centimeters from any other grounded conducting surface.
2. Connect EUT to the power mains through a line impedance stabilization network (LISN).
3. All the support units are connecting to the other LISN.
4. The LISN provides 50 ohm coupling impedance for the measuring instrument.
5. The FCC states that a 50 ohm, 50 microhenry LISN should be used.
6. Both sides of AC line were checked for maximum conducted interference.
7. The frequency range from 150 kHz to 30 MHz was searched.
8. Set the test-receiver system to Peak Detect Function and specified bandwidth (IF Bandwidth = 9kHz) with Maximum Hold Mode. Then measurement is also conducted by Average Detector and Quasi-Peak Detector Function respectively.

3.9.4 Test Setup

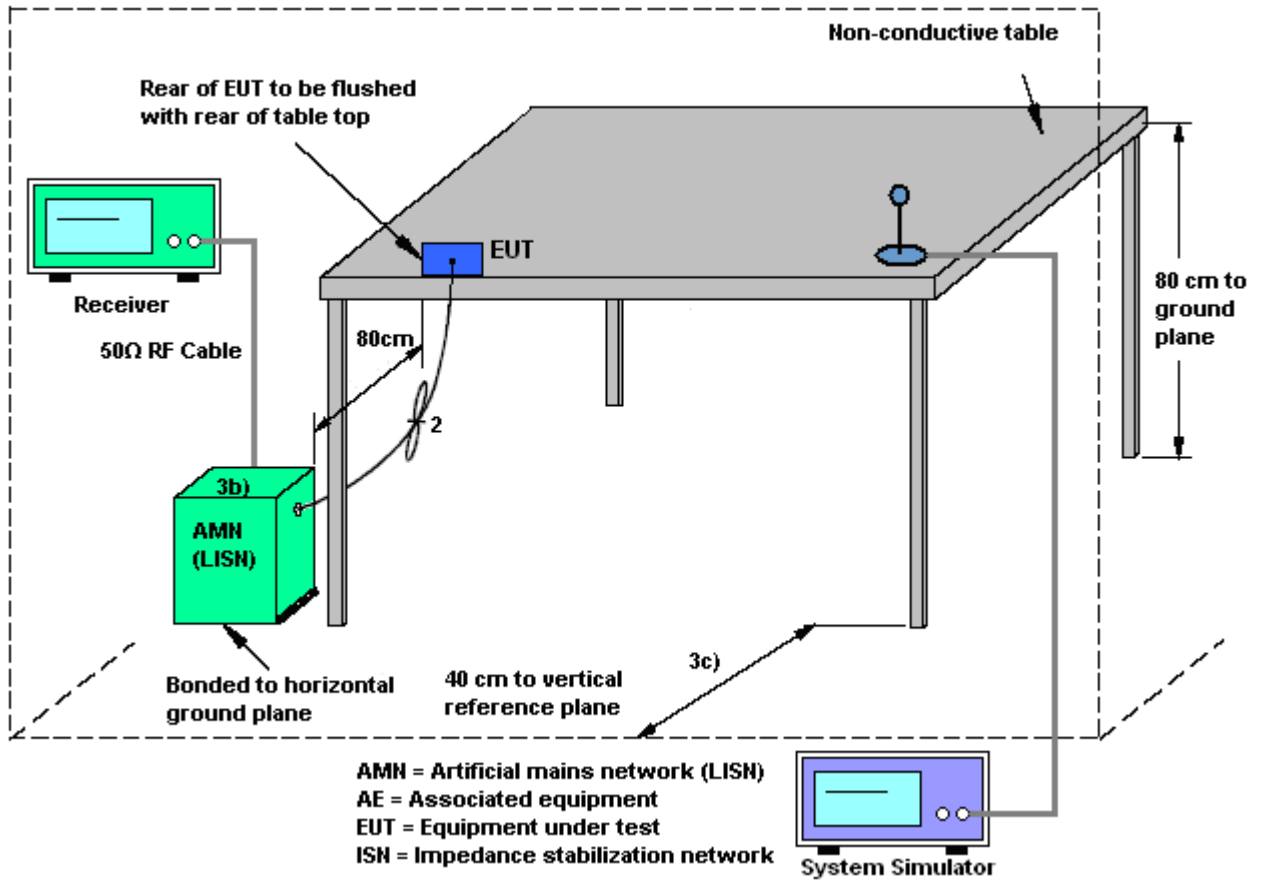



3.9.5 Test Result of AC Conducted Emission

Test Mode :	Mode 1	Temperature :	20~22°C
Test Engineer :	Cosmo Xu	Relative Humidity :	45~47%
Test Voltage :	120Vac / 60Hz	Phase :	Line
Function Type :	GSM850 Idle + Bluetooth Link + WLAN(2.4GHz) Link + MP3 + Earphone + USB Cable (Charging from Adapter)		

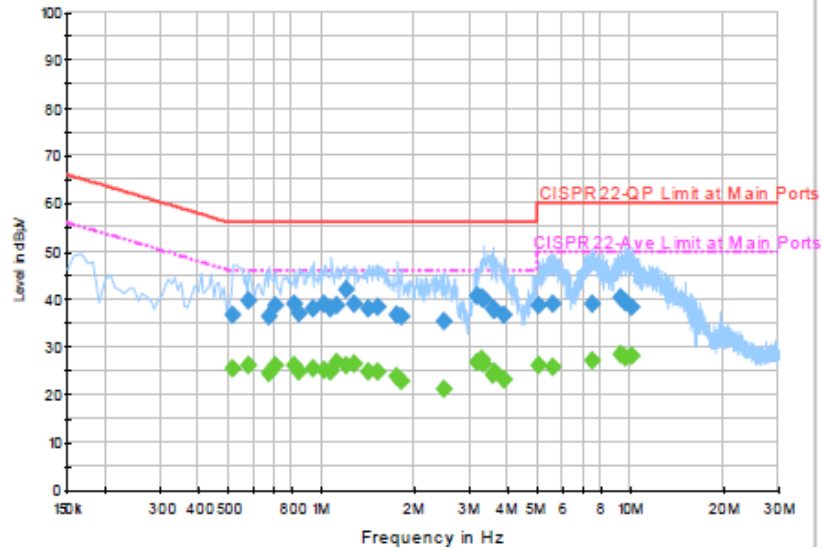

Final Result : Quasi-Peak

Frequency (MHz)	Quasi-Peak (dBµV)	Filter	Line	Corr. (dB)	Margin (dB)	Limit (dBµV)
0.518000	36.7	Off	L1	19.4	19.3	56.0
0.582000	39.6	Off	L1	19.4	16.4	56.0
0.678000	36.4	Off	L1	19.5	19.6	56.0
0.710000	38.5	Off	L1	19.5	17.5	56.0
0.814000	38.9	Off	L1	19.5	17.1	56.0
0.846000	36.9	Off	L1	19.6	19.1	56.0
0.942000	37.8	Off	L1	19.5	18.2	56.0
1.022000	38.9	Off	L1	19.4	17.1	56.0
1.070000	37.9	Off	L1	19.5	18.1	56.0
1.118000	38.6	Off	L1	19.5	17.4	56.0
1.198000	42.0	Off	L1	19.5	14.0	56.0
1.270000	39.0	Off	L1	19.5	17.0	56.0
1.414000	37.9	Off	L1	19.4	18.1	56.0
1.526000	38.3	Off	L1	19.4	17.7	56.0



Test Mode :	Mode 1	Temperature :	20~22°C
Test Engineer :	Cosmo Xu	Relative Humidity :	45~47%
Test Voltage :	120Vac / 60Hz	Phase :	Line
Function Type :	GSM850 Idle + Bluetooth Link + WLAN(2.4GHz) Link + MP3 + Earphone + USB Cable (Charging from Adapter)		

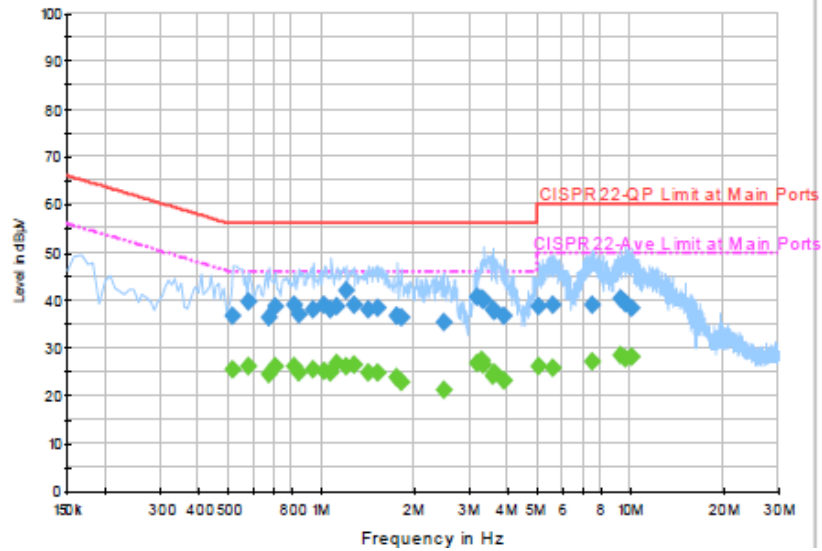

Final Result : Quasi-Peak

Frequency (MHz)	Quasi-Peak (dBµV)	Filter	Line	Corr. (dB)	Margin (dB)	Limit (dBµV)
1.750000	36.6	Off	L1	19.6	19.4	56.0
1.806000	36.4	Off	L1	19.6	19.6	56.0
2.478000	35.3	Off	L1	19.5	20.7	56.0
3.166000	40.5	Off	L1	19.6	15.5	56.0
3.278000	40.1	Off	L1	19.6	15.9	56.0
3.334000	40.0	Off	L1	19.6	16.0	56.0
3.566000	37.8	Off	L1	19.5	18.2	56.0
3.622000	37.6	Off	L1	19.5	18.4	56.0
3.902000	36.6	Off	L1	19.5	19.4	56.0
5.030000	38.7	Off	L1	19.6	21.3	60.0
5.622000	38.9	Off	L1	19.6	21.1	60.0
7.542000	39.1	Off	L1	19.6	20.9	60.0
9.294000	40.2	Off	L1	19.6	19.8	60.0
9.606000	39.3	Off	L1	19.7	20.7	60.0
10.022000	38.3	Off	L1	19.6	21.7	60.0



Test Mode :	Mode 1	Temperature :	20~22°C
Test Engineer :	Cosmo Xu	Relative Humidity :	45~47%
Test Voltage :	120Vac / 60Hz	Phase :	Line
Function Type :	GSM850 Idle + Bluetooth Link + WLAN(2.4GHz) Link + MP3 + Earphone + USB Cable (Charging from Adapter)		

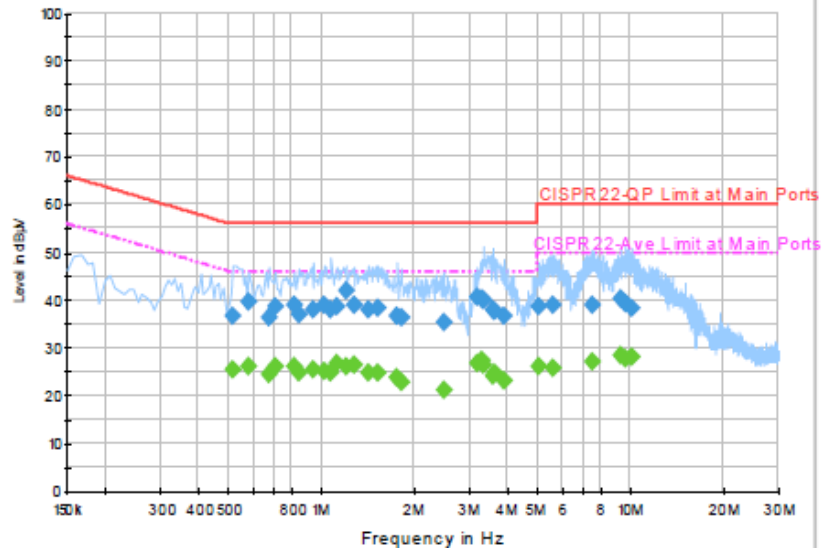

Final Result : Average

Frequency (MHz)	Average (dBµV)	Filter	Line	Corr. (dB)	Margin (dB)	Limit (dBµV)
0.518000	25.4	Off	L1	19.4	20.6	46.0
0.582000	26.2	Off	L1	19.4	19.8	46.0
0.678000	24.5	Off	L1	19.5	21.5	46.0
0.710000	25.9	Off	L1	19.5	20.1	46.0
0.814000	25.9	Off	L1	19.5	20.1	46.0
0.846000	24.7	Off	L1	19.6	21.3	46.0
0.942000	25.5	Off	L1	19.5	20.5	46.0
1.022000	25.2	Off	L1	19.4	20.8	46.0
1.070000	24.7	Off	L1	19.5	21.3	46.0
1.118000	26.7	Off	L1	19.5	19.3	46.0
1.198000	26.2	Off	L1	19.5	19.8	46.0
1.270000	26.2	Off	L1	19.5	19.8	46.0
1.414000	24.8	Off	L1	19.4	21.2	46.0
1.526000	24.9	Off	L1	19.4	21.1	46.0



Test Mode :	Mode 1	Temperature :	20~22°C
Test Engineer :	Cosmo Xu	Relative Humidity :	45~47%
Test Voltage :	120Vac / 60Hz	Phase :	Line
Function Type :	GSM850 Idle + Bluetooth Link + WLAN(2.4GHz) Link + MP3 + Earphone + USB Cable (Charging from Adapter)		

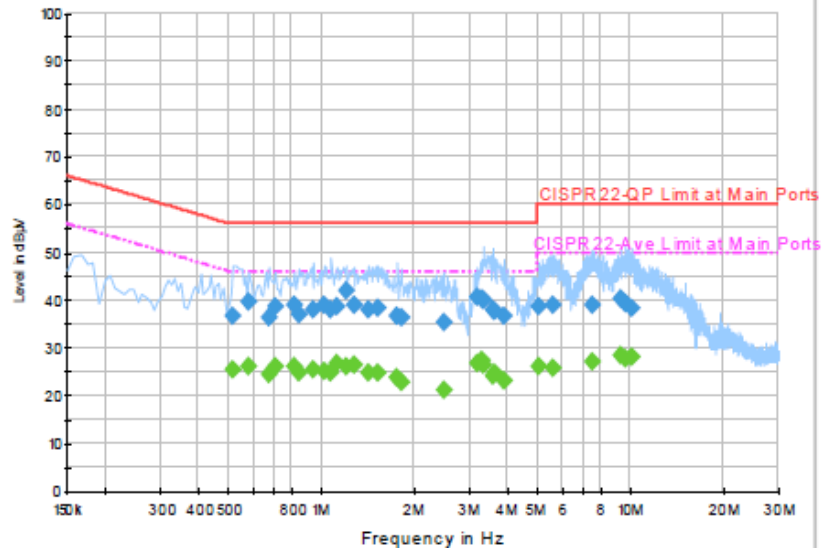

Final Result : Average

Frequency (MHz)	Average (dBµV)	Filter	Line	Corr. (dB)	Margin (dB)	Limit (dBµV)
1.750000	23.7	Off	L1	19.6	22.3	46.0
1.806000	22.9	Off	L1	19.6	23.1	46.0
2.478000	21.2	Off	L1	19.5	24.8	46.0
3.166000	26.8	Off	L1	19.6	19.2	46.0
3.278000	27.5	Off	L1	19.6	18.5	46.0
3.334000	26.5	Off	L1	19.6	19.5	46.0
3.566000	24.1	Off	L1	19.5	21.9	46.0
3.622000	24.6	Off	L1	19.5	21.4	46.0
3.902000	23.1	Off	L1	19.5	22.9	46.0
5.030000	26.0	Off	L1	19.6	24.0	50.0
5.622000	25.8	Off	L1	19.6	24.2	50.0
7.542000	27.0	Off	L1	19.6	23.0	50.0
9.294000	28.5	Off	L1	19.6	21.5	50.0
9.606000	27.6	Off	L1	19.7	22.4	50.0
10.022000	28.0	Off	L1	19.6	22.0	50.0



Test Mode :	Mode 1	Temperature :	20~22°C
Test Engineer :	Cosmo Xu	Relative Humidity :	45~47%
Test Voltage :	120Vac / 60Hz	Phase :	Neutral
Function Type :	GSM850 Idle + Bluetooth Link + WLAN(2.4GHz) Link + MP3 + Earphone + USB Cable (Charging from Adapter)		

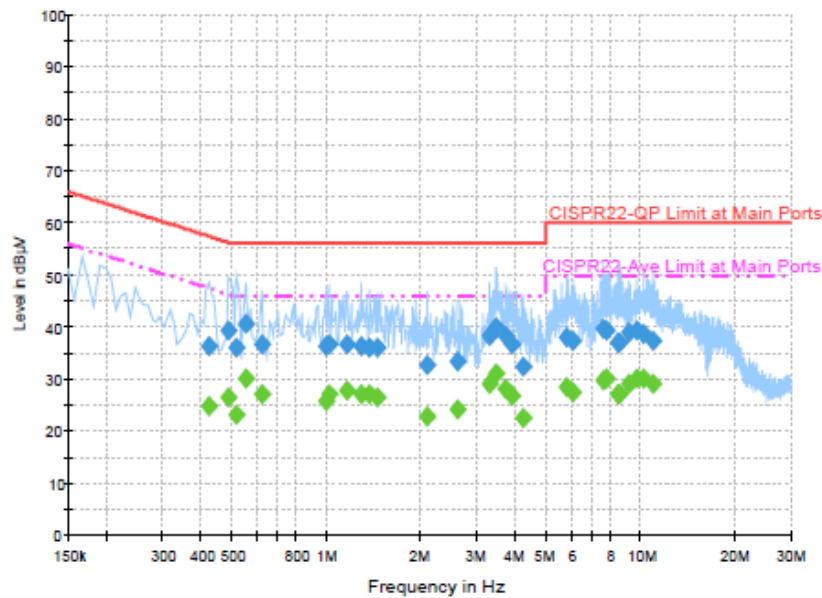

Final Result : Quasi-Peak

Frequency (MHz)	Quasi-Peak (dBµV)	Filter	Line	Corr. (dB)	Margin (dB)	Limit (dBµV)
0.422000	36.2	Off	N	19.4	21.2	57.4
0.486000	39.2	Off	N	19.4	17.0	56.2
0.518000	36.0	Off	N	19.4	20.0	56.0
0.550000	40.6	Off	N	19.4	15.4	56.0
0.622000	36.6	Off	N	19.4	19.4	56.0
0.990000	36.3	Off	N	19.5	19.7	56.0
1.014000	36.7	Off	N	19.5	19.3	56.0
1.158000	36.6	Off	N	19.5	19.4	56.0
1.286000	36.2	Off	N	19.5	19.8	56.0
1.366000	36.0	Off	N	19.5	20.0	56.0
1.446000	36.0	Off	N	19.6	20.0	56.0
2.086000	32.6	Off	N	19.5	23.4	56.0
2.606000	33.3	Off	N	19.5	22.7	56.0
3.302000	38.4	Off	N	19.6	17.6	56.0



Test Mode :	Mode 1	Temperature :	20~22°C
Test Engineer :	Cosmo Xu	Relative Humidity :	45~47%
Test Voltage :	120Vac / 60Hz	Phase :	Neutral
Function Type :	GSM850 Idle + Bluetooth Link + WLAN(2.4GHz) Link + MP3 + Earphone + USB Cable (Charging from Adapter)		

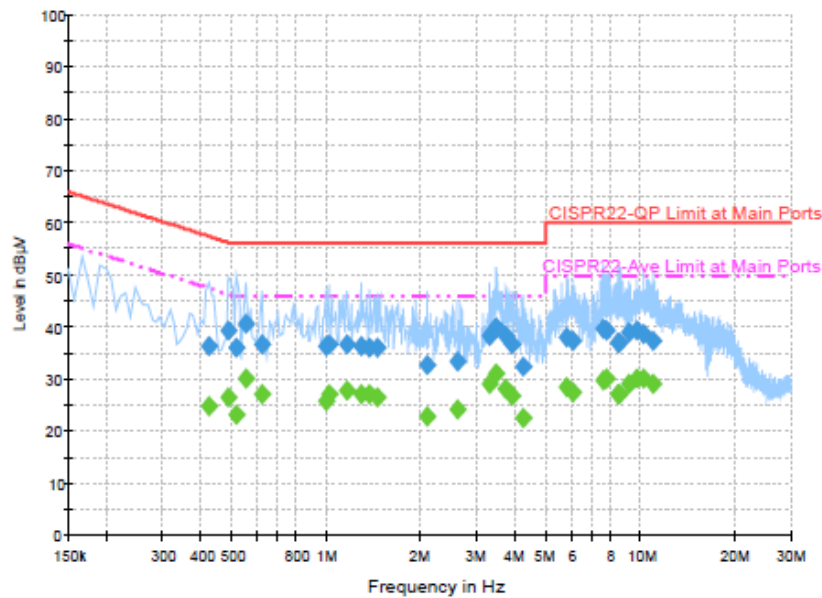

Final Result : Quasi-Peak

Frequency (MHz)	Quasi-Peak (dBµV)	Filter	Line	Corr. (dB)	Margin (dB)	Limit (dBµV)
3.470000	39.8	Off	N	19.6	16.2	56.0
3.726000	38.1	Off	N	19.6	17.9	56.0
3.902000	36.6	Off	N	19.6	19.4	56.0
4.222000	32.3	Off	N	19.6	23.7	56.0
5.806000	37.9	Off	N	19.6	22.1	60.0
6.054000	37.2	Off	N	19.6	22.8	60.0
7.598000	39.5	Off	N	19.6	20.5	60.0
7.774000	39.2	Off	N	19.5	20.8	60.0
8.454000	37.0	Off	N	19.6	23.0	60.0
8.502000	36.9	Off	N	19.7	23.1	60.0
9.158000	39.0	Off	N	19.7	21.0	60.0
9.750000	39.1	Off	N	19.7	20.9	60.0
10.214000	38.6	Off	N	19.7	21.4	60.0
10.918000	37.2	Off	N	19.7	22.8	60.0



Test Mode :	Mode 1	Temperature :	20~22°C
Test Engineer :	Cosmo Xu	Relative Humidity :	45~47%
Test Voltage :	120Vac / 60Hz	Phase :	Neutral
Function Type :	GSM850 Idle + Bluetooth Link + WLAN(2.4GHz) Link + MP3 + Earphone + USB Cable (Charging from Adapter)		

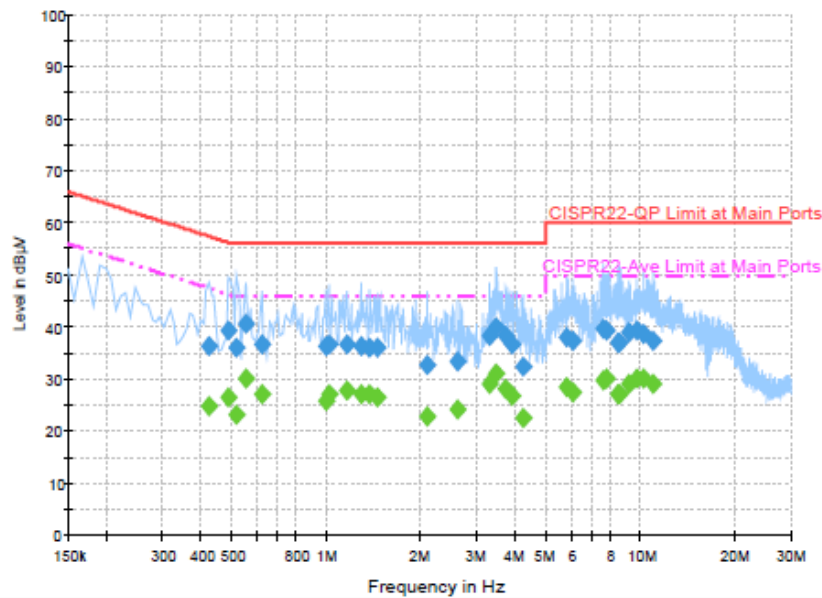

Final Result : Average

Frequency (MHz)	Average (dBµV)	Filter	Line	Corr. (dB)	Margin (dB)	Limit (dBµV)
0.422000	24.9	Off	N	19.4	22.5	47.4
0.486000	26.5	Off	N	19.4	19.7	46.2
0.518000	23.2	Off	N	19.4	22.8	46.0
0.550000	30.0	Off	N	19.4	16.0	46.0
0.622000	27.1	Off	N	19.4	18.9	46.0
0.990000	25.7	Off	N	19.5	20.3	46.0
1.014000	27.0	Off	N	19.5	19.0	46.0
1.158000	27.8	Off	N	19.5	18.2	46.0
1.286000	27.1	Off	N	19.5	18.9	46.0
1.366000	27.0	Off	N	19.5	19.0	46.0
1.446000	26.5	Off	N	19.6	19.5	46.0
2.086000	22.8	Off	N	19.5	23.2	46.0
2.606000	24.2	Off	N	19.5	21.8	46.0
3.302000	29.2	Off	N	19.6	16.8	46.0



Test Mode :	Mode 1	Temperature :	20~22°C
Test Engineer :	Cosmo Xu	Relative Humidity :	45~47%
Test Voltage :	120Vac / 60Hz	Phase :	Neutral
Function Type :	GSM850 Idle + Bluetooth Link + WLAN(2.4GHz) Link + MP3 + Earphone + USB Cable (Charging from Adapter)		

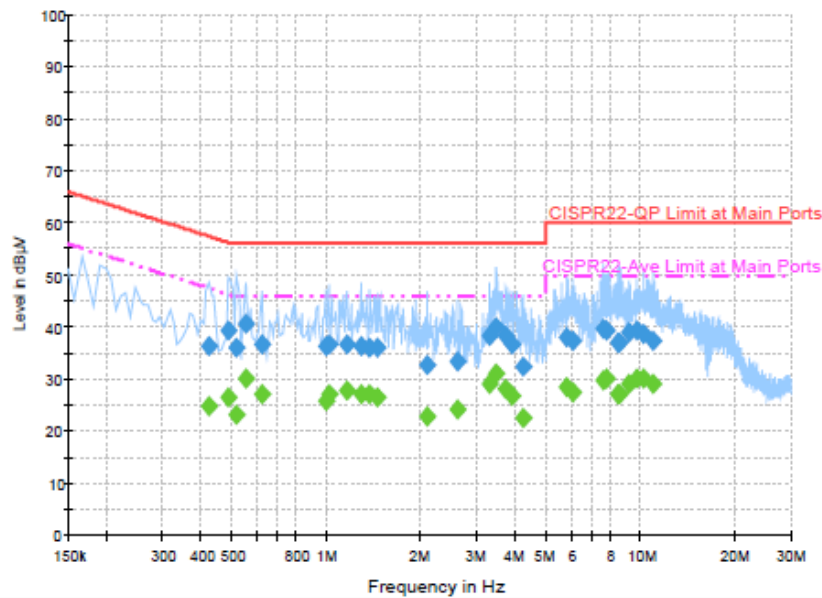

Final Result : Average

Frequency (MHz)	Average (dBµV)	Filter	Line	Corr. (dB)	Margin (dB)	Limit (dBµV)
3.470000	30.9	Off	N	19.6	15.1	46.0
3.726000	28.0	Off	N	19.6	18.0	46.0
3.902000	26.8	Off	N	19.6	19.2	46.0
4.222000	22.4	Off	N	19.6	23.6	46.0
5.806000	28.4	Off	N	19.6	21.6	50.0
6.054000	27.3	Off	N	19.6	22.7	50.0
7.598000	29.8	Off	N	19.6	20.2	50.0
7.774000	29.9	Off	N	19.5	20.1	50.0
8.454000	26.9	Off	N	19.6	23.1	50.0
8.502000	27.0	Off	N	19.7	23.0	50.0
9.158000	29.1	Off	N	19.7	20.9	50.0
9.750000	30.2	Off	N	19.7	19.8	50.0
10.214000	30.1	Off	N	19.7	19.9	50.0
10.918000	29.0	Off	N	19.7	21.0	50.0



3.10 Antenna Requirements

3.10.1 Standard Applicable

If directional gain of transmitting antennas is greater than 6dBi, the power shall be reduced by the same level in dB comparing to gain minus 6dBi. The use of a permanently attached antenna or of an antenna that uses a unique coupling to the intentional radiator shall be considered sufficient to comply with the FCC rule.

3.10.2 Antenna Anti-Replacement Construction

An embedded-in antenna design is used.

3.10.3 Antenna Gain

The antenna peak gain of EUT is less than 6 dBi. Therefore, it is not necessary to reduce maximum peak output power limit.



4 List of Measuring Equipment

Instrument	Manufacturer	Model No.	Serial No.	Characteristics	Calibration Date	Test Date	Due Date	Remark
Spectrum Analyzer	Rohde & Schwarz	FSP40	100055	9kHz~40GHz	Jun. 09, 2014	Aug. 23, 2014~ Sep. 15, 2014	Jun. 08, 2015	Conducted (TH02-HY)
Power Meter	Agilent	E4416A	GB41292344	300MHz~40GHz	Jan. 28, 2014	Aug. 23, 2014~ Sep. 15, 2014	Jan. 27, 2015	Conducted (TH02-HY)
Power Sensor	Agilent	E9327A	US40441548	300MHz~40GHz	Jan. 28, 2014	Aug. 23, 2014~ Sep. 15, 2014	Jan. 27, 2015	Conducted (TH02-HY)
Spectrum Analyzer	R&S	FSP30	101067	9kHz ~ 30GHz	Nov. 20, 2013	Aug. 23, 2014~ Sep. 12, 2014	Nov. 19, 2014	Radiation (03CH06-HY)
Spectrum Analyzer	Agilent	E4408B	MY44211030	9kHz ~ 26.5GHz	Dec. 02, 2013	Aug. 23, 2014~ Sep. 12, 2014	Dec. 01, 2014	Radiation (03CH06-HY)
EMI Test Receiver	R&S	ESVS10	834468/0003	20MHz ~ 1000MHz	May 06, 2014	Aug. 23, 2014~ Sep. 12, 2014	May 05, 2015	Radiation (03CH06-HY)
Loop Antenna	Rohde & Schwarz	HFH2-Z2	100330	9kHz ~ 30MHz	Jul. 28, 2014	Aug. 23, 2014~ Sep. 12, 2014	Jul. 27, 2015	Radiation (03CH06-HY)
Bilog Antenna	Schaffner	CBL6112B	2885	30MHz ~ 2GHz	Oct. 10, 2013	Aug. 23, 2014~ Sep. 12, 2014	Oct. 09, 2014	Radiation (03CH06-HY)
Double Ridge Horn Antenna	EMCO	3117	00066583	1GHz ~ 18GHz	Jul. 24, 2014	Aug. 23, 2014~ Sep. 12, 2014	Jul. 23, 2015	Radiation (03CH06-HY)
Amplifier	SONOMA	310N	186713	9kHz ~ 1GHz	Apr. 16, 2014	Aug. 23, 2014~ Sep. 12, 2014	Apr. 15, 2015	Radiation (03CH06-HY)
Preamplifier	EMCI	EMC051845	SN980048	1GHz ~ 18GHz	Jul. 17, 2014	Aug. 23, 2014~ Sep. 12, 2014	Jul. 16, 2015	Radiation (03CH06-HY)
SHF-EHF Horn Antenna	SCHWARZBECK	BBHA 9170	BBHA9170251	15GHz ~ 40GHz	Oct. 03, 2013	Aug. 23, 2014~ Sep. 12, 2014	Oct. 02, 2014	Radiation (03CH06-HY)
Preamplifier	Agilent	8449B	3008A01917	1GHz ~ 26.5GHz	Apr. 10, 2014	Aug. 23, 2014~ Sep. 12, 2014	Apr. 09, 2015	Radiation (03CH06-HY)
Turn Table	INN-CO	DS2000	420/650/00	0 ~ 360 degree	N/A	Aug. 23, 2014~ Sep. 12, 2014	N/A	Radiation (03CH06-HY)
Antenna Mast	MF	MF-7802	MF780208212	1 m ~ 4 m	N/A	Aug. 23, 2014~ Sep. 12, 2014	N/A	Radiation (03CH06-HY)
EMI Test Receiver	Rohde & Schwarz	ESCS 30	100356	9kHz ~ 2.75GHz	Nov. 15, 2013	Aug. 19, 2014	Nov. 14, 2014	Conduction (CO05-HY)
LISN (for auxiliary equipment)	Rohde & Schwarz	ENV216	100081	9kHz ~ 30MHz	Dec. 12, 2013	Aug. 19, 2014	Dec. 11, 2014	Conduction (CO05-HY)
LISN	Rohde & Schwarz	ENV216	100080	9kHz ~ 30MHz	Dec. 04, 2013	Aug. 19, 2014	Dec. 03, 2014	Conduction (CO05-HY)
AC Power Source	ChainTek	APC-1000W	N/A	N/A	N/A	Aug. 19, 2014	N/A	Conduction (CO05-HY)



5 Uncertainty of Evaluation

Uncertainty of Conducted Emission Measurement (150 kHz ~ 30 MHz)

Measuring Uncertainty for a Level of Confidence of 95% ($U = 2Uc(y)$)	2.26
---	------

Uncertainty of Radiated Emission Measurement (30 MHz ~ 1000 MHz)

Measuring Uncertainty for a Level of Confidence of 95% ($U = 2Uc(y)$)	4.50
---	------



Appendix A. Radiated Spurious Emission

Test Engineer :	Luke Chang		
Temperature :	22~23°C	Relative Humidity :	42~43%

15C 2.4GHz 2400~2483.5MHz

BT (Band Edge @ 3m)

BT	Note	Frequency	Level	Over	Limit	Read	Antenna	Cable	Preamp	Ant	Table	Peak	Pol.
		(MHz)	(dBμV/m)	(dB)	(dBμV/m)	(dBμV)	(dB/m)	(dB)	(dB)	(cm)	(deg)	(P/A)	(H/V)
BT CH00 2402MHz		2354.59	48	-26	74	44.59	31.92	6.14	34.65	126	39	P	H
		2354.59	23.27	-30.73	54							A	H
	*	2402	99.58	-	-	96.07	31.94	6.21	34.64	126	39	P	H
	*	2402	74.85	-	-							A	H
		2368.63	47.08	-26.92	74	43.63	31.93	6.17	34.65	177	72	P	V
		2368.63	22.35	-31.65	54							A	V
	*	2402	94.97	-	-	91.46	31.94	6.21	34.64	177	72	P	V
	*	2402	70.24	-	-							A	V
BT CH 39 2441MHz		2312.47	47.46	-26.54	74	44.15	31.89	6.07	34.65	100	29	P	H
		2312.47	22.73	-31.27	54							A	H
	*	2441.1	102.61	-	-	99.01	31.97	6.27	34.64	100	29	P	H
	*	2441.1	77.88	-	-							A	H
		2491.26	47.35	-26.65	74	43.68	32	6.3	34.63	100	29	P	H
		2491.26	22.62	-31.38	54							A	H
		2335.65	48.01	-25.99	74	44.65	31.91	6.1	34.65	200	71	P	V
		2335.65	23.28	-30.72	54							A	V
	*	2441	98.49	-	-	94.89	31.97	6.27	34.64	200	71	P	V
	*	2441	73.76	-	-							A	V
		2497.53	47.81	-26.19	74	44.1	32	6.34	34.63	200	71	P	V
		2497.53	23.08	-30.92	54							A	V



BT CH 78 2480MHz	*	2480	101.83	-	-	98.17	31.99	6.3	34.63	100	32	P	H
	*	2480	77.1	-	-							A	H
		2483.5	59.06	-14.94	74	55.4	31.99	6.3	34.63	100	32	P	H
		2483.5	34.33	-19.67	54							A	H
	*	2480	97.96	-	-	94.3	31.99	6.3	34.63	200	70	P	V
	*	2480	73.23	-	-							A	V
		2483.5	55.25	-18.75	74	51.59	31.99	6.3	34.63	200	70	P	V
		2483.5	30.52	-23.48	54							A	V

Remark	<ol style="list-style-type: none"> No other spurious found. All results are PASS against Peak and Average limit line.
--------	---



15C 2.4GHz 2400~2483.5MHz

BT (Harmonic @ 3m)

BT	Note	Frequency	Level	Over	Limit	Read	Antenna	Cable	Preamp	Ant	Table	Peak	Pol.
				Limit	Line	Level	Factor	Loss	Factor	Pos	Pos	Avg.	
		(MHz)	(dBμV/m)	(dB)	(dBμV/m)	(dBμV)	(dB/m)	(dB)	(dB)	(cm)	(deg)	(P/A)	(H/V)
BT CH 00 2402MHz		4804	40.38	-33.62	74	58.37	34.35	8.52	60.86	100	0	P	H
		4804	15.65	-38.35	54							A	H
		4804	38.81	-35.19	74	56.8	34.35	8.52	60.86	100	0	P	V
		4804	14.08	-39.92	54							A	V
BT CH 39 2441MHz		4882	40.05	-33.95	74	57.57	34.4	8.77	60.69	100	0	P	H
		4882	15.32	-38.68	54							A	H
		7323	43.11	-30.89	74	55.96	35.73	11.95	60.53	100	0	P	H
		7323	18.38	-35.62	54							A	H
		4882	40.53	-33.47	74	58.05	34.4	8.77	60.69	100	0	P	V
		4882	15.8	-38.2	54							A	V
		7323	42.5	-31.5	74	55.35	35.73	11.95	60.53	100	0	P	V
		7323	17.77	-36.23	54							A	V
BT CH 78 2480MHz		4960	40.17	-33.83	74	57.16	34.47	9.02	60.48	100	0	P	H
		4960	15.44	-38.56	54							A	H
		7440	41.27	-32.73	74	54.13	35.71	12.01	60.58	100	0	P	H
		7440	16.54	-37.46	54							A	H
		4960	39.71	-34.29	74	56.7	34.47	9.02	60.48	100	0	P	V
		4960	14.98	-39.02	54							A	V
		7440	42.28	-31.72	74	55.14	35.71	12.01	60.58	100	0	P	V
		7440	17.55	-36.45	54							A	V
Remark	1. No other spurious found. 2. All results are PASS against Peak and Average limit line.												



**15C Emission below 1GHz
2.4GHz BT
(LF @ 3m)**

BT	Note	Frequency	Level	Over	Limit	Read	Antenna	Cable	Preamp	Ant	Table	Peak	Pol.	
				Limit	Line	Level	Factor	Loss	Factor	Pos	Pos	Avg.		
		(MHz)	(dBμV/m)	(dB)	(dBμV/m)	(dBμV)	(dB/m)	(dB)	(dB)	(cm)	(deg)	(P/A)	(H/V)	
2.4GHz BT LF		0.02231	33.72	-86.91	120.63	13.35	20.08	0.29				A	H	
		0.07662	25.89	-84.03	109.92	5.59	20.01	0.29				A	H	
		0.09672	21.99	-85.9	107.89	1.74	19.96	0.29				QP	H	
		0.12704	57.25	-48.28	105.53	37.02	19.94	0.29				A	H	
		0.13496	20.15	-84.85	105	-0.08	19.94	0.29				A	H	
		0.38154	46.61	-49.36	95.97	26.44	19.88	0.29				A	H	
		1.692	48.04	-15	63.04	27.79	19.92	0.33			100	28	QP	H
		14.408	36.04	-33.96	70	15.58	20.06	0.4					QP	H
		21.121	37.89	-32.11	70	16.92	20.54	0.43					QP	H
		28.385	36.08	-33.92	70	14.95	20.63	0.5					QP	H
		62.4	16.75	-23.25	40	41.23	6.4	0.89	31.77				P	H
		105.06	19.24	-24.26	43.5	38.27	11.6	1.12	31.75				P	H
		169.05	30.66	-12.84	43.5	50.98	9.82	1.61	31.75	151	220		P	H
		413.4	19.71	-26.29	46	32.87	16.45	2.22	31.83				P	H
		861.4	24.01	-21.99	46	31.63	20.81	3.26	31.69				P	H
		907.6	24.3	-21.7	46	31.37	21.02	3.37	31.46				P	H
		0.01461	34.87	-89.44	124.31	14.32	20.26	0.29					A	V
		0.07659	30.18	-79.74	109.92	9.86	20.03	0.29					A	V
		0.09668	24.63	-83.27	107.9	4.35	19.99	0.29					QP	V
		0.12716	51.05	-54.47	105.52	30.8	19.96	0.29					A	V
		0.14368	19.06	-85.4	104.46	-1.18	19.95	0.29					A	V
		0.45226	50.13	-44.37	94.5	29.94	19.9	0.29					A	V
		1.203	38.91	-27.09	66	18.68	19.92	0.31			100	309	QP	V
		11.944	36.84	-33.16	70	16.65	19.79	0.4					QP	V
		24.19	37.42	-32.58	70	16.91	20.06	0.45					QP	V
		27.115	36.96	-33.04	70	16.39	20.09	0.48					QP	V
		35.4	24.48	-15.52	40	40.59	14.98	0.7	31.79	148	301		P	V
		99.66	24.97	-18.53	43.5	44.82	10.8	1.1	31.75				P	V



		186.06	24.19	-19.31	43.5	45.45	9.02	1.47	31.75			P	V
		462.4	18.8	-27.2	46	31.11	17.25	2.33	31.89			P	V
		571.6	22.32	-23.68	46	32.39	19.31	2.64	32.02			P	V
		874	24.2	-21.8	46	31.64	20.9	3.3	31.64			P	V
Remark	1. No other spurious found. 2. All results are PASS against limit line.												



Note symbol

*	Fundamental Frequency which can be ignored. However, the level of any unwanted emissions shall not exceed the level of the fundamental frequency per 15.209(c).
!	Test result is over limit line.
P/A	Peak or Average
H/V	Horizontal or Vertical



A calculation example for radiated spurious emission is shown as below:

WIFI	Note	Frequency	Level	Over	Limit	Read	Antenna	Cable	Preamp	Ant	Table	Peak	Pol.
Ant.				Limit	Line	Level	Factor	Loss	Factor	Pos	Pos	Avg.	
1+2		(MHz)	(dBμV/m)	(dB)	(dBμV/m)	(dBμV)	(dB/m)	(dB)	(dB)	(cm)	(deg)	(P/A)	(H/V)
802.11b		2390	55.45	-18.55	74	54.51	32.22	4.58	35.86	103	308	P	H
CH 01													
2412MHz		2390	43.54	-10.46	54	42.6	32.22	4.58	35.86	103	308	A	H

- Level(dBμV/m) =
Antenna Factor(dB/m) + Cable Loss(dB) + Read Level(dBμV) - Preamp Factor(dB)
- Over Limit(dB) = Level(dBμV/m) – Limit Line(dBμV/m)

For Peak Limit @ 2390MHz:

- Level(dBμV/m)
= Antenna Factor(dB/m) + Cable Loss(dB) + Read Level(dBμV) - Preamp Factor(dB)
= 32.22(dB/m) + 4.58(dB) + 54.51(dBμV) – 35.86 (dB)
= 55.45 (dBμV/m)
- Over Limit(dB)
= Level(dBμV/m) – Limit Line(dBμV/m)
= 55.45(dBμV/m) – 74(dBμV/m)
= -18.55(dB)

For Average Limit @ 2390MHz:

- Level(dBμV/m)
= Antenna Factor(dB/m) + Cable Loss(dB) + Read Level(dBμV) - Preamp Factor(dB)
= 32.22(dB/m) + 4.58(dB) + 42.6(dBμV) – 35.86 (dB)
= 43.54 (dBμV/m)
- Over Limit(dB)
= Level(dBμV/m) – Limit Line(dBμV/m)
= 43.54(dBμV/m) – 54(dBμV/m)
= -10.46(dB)

Both peak and average measured complies with the limit line, so test result is “PASS”.