



FCC Test Report

APPLICANT : Motorola Mobility, LLC
EQUIPMENT : Mobile Cellular Phone
BRAND NAME : Motorola
MODEL NAME : 4027
FCC ID : IHDT56QB2
STANDARD : FCC 47 CFR FCC Part 15 Subpart B
CLASSIFICATION : Certification

The product was received on May 16, 2014 and testing was completed on Jun. 11, 2014. We, SPORTON INTERNATIONAL INC., would like to declare that the tested sample has been evaluated in accordance with the test procedures given in ANSI C63.4-2009 and has been in compliance with the applicable technical standards.

The test results in this report apply exclusively to the tested model / sample. Without written approval of SPORTON INTERNATIONAL INC., the test report shall not be reproduced except in full.

Reviewed by: Louis Wu / Manager

Approved by: Jones Tsai / Manager



SPORTON INTERNATIONAL INC.

No. 52, Hwa Ya 1st Rd., Hwa Ya Technology Park, Kwei-Shan Hsiang, Tao Yuan Hsien, Taiwan, R.O.C.



TABLE OF CONTENTS

REVISION HISTORY..... 3

SUMMARY OF TEST RESULT 4

1. GENERAL DESCRIPTION 5

 1.1. Applicant..... 5

 1.2. Manufacturer 5

 1.3. Product Feature of Equipment Under Test 5

 1.4. Product Specification subjective to this standard 6

 1.5. Modification of EUT 6

 1.6. Test Location 7

 1.7. Applicable Standards 7

2. TEST CONFIGURATION OF EQUIPMENT UNDER TEST 8

 2.1. Test Mode 8

 2.2. Connection Diagram of Test System 9

 2.3. Support Unit used in test configuration and system 9

 2.4. EUT Operation Test Setup 10

3. TEST RESULT 11

 3.1. Test of AC Conducted Emission Measurement 11

 3.2. Test of Radiated Emission Measurement 15

4. LIST OF MEASURING EQUIPMENT 20

5. UNCERTAINTY OF EVALUATION 21

APPENDIX A. ORIGINAL REPORT



SUMMARY OF TEST RESULT

Report Section	FCC Rule	IC Rule	Description	Limit	Result	Remark
3.1	15.107	ICES003 Section 6.1	AC Conducted Emission	< 15.107 limits < ICES003 6.1 limits	PASS	Under limit 8.40 dB at 0.150 MHz
3.2	15.109	ICES003 Section 6.2	Radiated Emission	< 15.109 limits < ICES003 6.2 limits	PASS	Under limit 5.30 dB at 240.060 MHz for Quasi-Peak



1. General Description

1.1. Applicant

Motorola Mobility, LLC
222 W Merchandise Mart Plaza, Suite 1800, Chicago, IL 60654, United States

1.2. Manufacturer

Motorola Mobility, LLC
222 W Merchandise Mart Plaza, Suite 1800, Chicago, IL 60654, United States

1.3. Product Feature of Equipment Under Test

Product Feature	
Equipment	Mobile Cellular Phone
Brand Name	Motorola
Model Name	4027
FCC ID	IHDT56QB2
IMEI Code	3592806050087487
EUT supports Radios application	GSM/EGPRS/WCDMA/HSPA WLAN 11b/g/n HT20 Bluetooth v2.1EDR Bluetooth v4.0-LE
HW Version	P2
SW Version	KXB21.45.38
EUT Stage	Identical Prototype

Remark: The above EUT's information was declared by manufacturer. Please refer to the specifications or user's manual for more detailed description.

Accessory List	
USB Cable	Brand Name : Foxlink
	Model Name : 6691-10FL-0387
Earphone	Brand Name : MOTOROLA
	Model Name : SJYN1181B
Battery	Brand Name : MOTOROLA
	Model Name : ED30



1.4. Product Specification subjective to this standard

Product Specification subjective to this standard	
Tx Frequency	GSM850 : 824.2 MHz ~ 848.8 MHz GSM1900 : 1850.2 MHz ~ 1909.8MHz WCDMA Band V : 826.4 MHz ~ 846.6 MHz WCDMA Band IV : 1712.4 MHz ~ 1752.6 MHz WCDMA Band II : 1852.4 MHz ~ 1907.6 MHz 802.11b/g/n: 2412 MHz ~ 2462 MHz Bluetooth: 2402 MHz ~ 2480 MHz
Rx Frequency	GSM850 : 869.2 MHz ~ 893.8 MHz GSM1900 : 1930.2 MHz ~ 1989.8 MHz WCDMA Band V : 871.4 MHz ~ 891.6 MHz WCDMA Band IV : 2112.4 MHz ~ 2152.6 MHz WCDMA Band II : 1932.4 MHz ~ 1987.6 MHz 802.11b/g/n: 2412 MHz ~ 2462 MHz Bluetooth: 2402 MHz ~ 2480 MHz GPS : 1.57542 GHz
Antenna Type	WWAN : PIFA Antenna WLAN : PIFA Antenna Bluetooth : PIFA Antenna GPS : PIFA Antenna
Type of Modulation	GSM: GMSK GPRS: GMSK EDGE(MCS 0-4): GMSK / (MCS 5-9): 8PSK WCDMA: QPSK (Uplink) HSDPA: 16QAM (Downlink) HSUPA: QPSK (Uplink) 802.11b : DSSS (DBPSK / DQPSK / CCK) 802.11g/n : OFDM (BPSK / QPSK / 16QAM / 64QAM) Bluetooth LE : GFSK Bluetooth (1Mbps) : GFSK Bluetooth (2Mbps) : $\pi/4$ -DQPSK Bluetooth (3Mbps) : 8-DPSK GPS : BPSK

1.5. Modification of EUT

No modifications are made to the EUT during all test items.



1.6. Test Location

Sporton Lab is accredited to ISO 17025 by Taiwan Accreditation Foundation (TAF code : 1190) and the FCC designation TW1022 under the FCC 2.948(e) by Mutual Recognition Agreement (MRA) in FCC Test.

Test Site	SPORTON INTERNATIONAL INC.	
Test Site Location	No. 52, Hwa Ya 1 st Rd., Hwa Ya Technology Park, Kwei-Shan Hsiang, Tao Yuan Hsien, Taiwan, R.O.C. TEL: +886-3-327-3456 FAX: +886-3-328-4978	
Test Site No.	Sporton Site No.	
	CO05-HY	03CH06-HY

1.7. Applicable Standards

According to the specifications of the manufacturer, the EUT must comply with the requirements of the following standards:

- ♦ FCC 47 CFR FCC Part 15 Subpart B
- ♦ ANSI C63.4-2009

Remark:

1. All test items were verified and recorded according to the standards and without any deviation during the test.
2. For FCC 15 Subpart B - Unintentional Radiators, device supports FM Radio (Receiver) shall be authorized as "FM broadcast receiver" per the Section 15.101 (a) Equipment authorization of unintentional radiators.
3. For other Unintentional Radiators features of this EUT, test reports are issued separately.
Per the Note of the Section 15.101, when device supports features (USB, FM Radio, digital devices...etc.) more than one category of authorization, type of authorization shall be appropriately chosen for FCC 15B compliance rule, and the Section 15.101 (b), only those receivers that operate (tune) within the frequency range of 30-960 MHz, CB receivers and radar detectors are subject to the authorizations shown in paragraph (a) of the Section 15.101. However, receivers indicated as being subject to Declaration of Conformity that are contained within a transceiver, the transmitter portion of which is subject to certification, shall be authorized under the verification procedure



2. Test Configuration of Equipment Under Test

2.1. Test Mode

The EUT has been associated with peripherals pursuant to ANSI C63.4-2009 and configuration operated in a manner tended to maximize its emission characteristics in a typical application.

Frequency range investigated: conduction (150 kHz to 30 MHz), radiation (30MHz to the 5th harmonic of the highest fundamental frequency or to 40 GHz, whichever is lower).

The EUT uses a USB interface and microprocessor operating 800MHz which is the maximum frequency used.

The following tables are showing the test modes as the worst cases and recorded in this report.

Item	EUT Configuration	Test Condition		
		EMI AC	EMI RE<1G	EMI RE≥1G
1.	Data application transferred mode (EUT with notebook)	☒	☒	☒

Abbreviations:

- EMI AC: AC conducted emissions
- EMI RE ≥ 1G: EUT radiated emissions ≥ 1GHz
- EMI RE < 1G: EUT radiated emissions < 1GHz

Test Items	EUT Configure Mode	Function Type
AC Conducted Emission	1	Mode 1: GSM850 Idle + Bluetooth Idle + WLAN Idle + Earphone + GPS Rx + Battery + USB Cable (Data Link with Notebook) Mode 2: WCDMA Band II Idle + Bluetooth Idle + WLAN Idle + Earphone + GPS Rx + Battery + USB Cable (Data Link with Notebook)
Radiated Emissions < 1GHz	1	Mode 1: GSM850 Idle + Bluetooth Idle + WLAN Idle + Earphone + GPS Rx + Battery + USB Cable (Data Link with Notebook) Mode 2: WCDMA Band II Idle + Bluetooth Idle + WLAN Idle + Earphone + GPS Rx + Battery + USB Cable (Data Link with Notebook)
Radiated Emissions ≥ 1GHz	1	Mode 1: GSM850 Idle + Bluetooth Idle + WLAN Idle + Earphone + GPS Rx + Battery + USB Cable (Data Link with Notebook)
Remark: Data Link with Notebook means data application transferred mode between EUT and Notebook.		

2.2. Connection Diagram of Test System

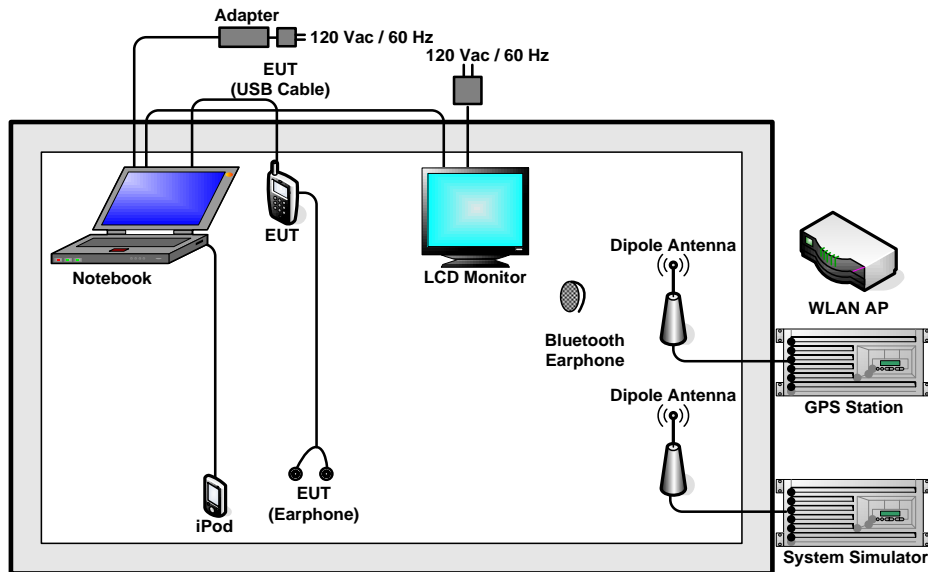

2.3. Support Unit used in test configuration and system

Item	Equipment	Trade Name	Model Name	FCC ID	Data Cable	Power Cord
1.	System Simulator	R&S	CMU 200	N/A	N/A	Unshielded, 1.8 m
2.	GPS Station	Pendulum	GSG-54	N/A	N/A	Unshielded, 1.8 m
3.	WLAN AP	D-Link	DIR-628	KA2DIR628A2	N/A	Unshielded, 1.8 m
4.	Bluetooth Earphone	Sony Ericsson	MW600	PY7DDA-2029	N/A	N/A
5.	Notebook	DELL	Latitude E6320	FCC DoC	N/A	AC I/P: Unshielded, 1.2 m DC O/P: Shielded, 1.8 m
6.	iPod	Apple	A1285	FCC DoC	Shielded, 1.0 m	N/A
7.	LCD MONITOR	Dell	U2410	FCC DoC	Shielded, 1.6m	Unshielded, 1.8m
8.	SD Card	SanDisk	MicroSD HC	FCC DoC	N/A	N/A



2.4. EUT Operation Test Setup

The EUT was in GSM idle mode during the testing. The EUT was synchronized to the BCCH, and was in continuous receiving mode by setting system simulator's paging reorganization.

At the same time, the EUT was attached to the Bluetooth earphone and WLAN AP, and the following programs installed in the EUT were programmed during the test.

1. Data application is transferred between Laptop and EUT via USB cable.
2. Execute "GPS Test" to make the EUT receive continuously signals from GPS station.



3. Test Result

3.1. Test of AC Conducted Emission Measurement

3.1.1 Limits of AC Conducted Emission

For equipment that is designed to be connected to the public utility (AC) power line, the radio frequency voltage that is conducted back onto the AC power line on any frequency or frequencies within the band 150 kHz to 30 MHz shall not exceed the limits in the following table.

Frequency of emission (MHz)	Conducted limit (dBuV)	
	Quasi-peak	Average
0.15-0.5	66 to 56*	56 to 46*
0.5-5	56	46
5-30	60	50

*Decreases with the logarithm of the frequency.

3.1.2 Measuring Instruments

The measuring equipment is listed in the section 4 of this test report.

3.1.3 Test Procedure

1. The EUT was placed 0.4 meter from the conducting wall of the shielding room was kept at least 80 centimeters from any other grounded conducting surface.
2. Connect EUT to the power mains through a line impedance stabilization network (LISN).
3. All the support units are connecting to the other LISN.
4. The LISN provides 50 ohm coupling impedance for the measuring instrument.
5. The FCC states that a 50 ohm, 50 microhenry LISN should be used.
6. Both sides of AC line were checked for maximum conducted interference.
7. The frequency range from 150 kHz to 30 MHz was searched.
8. Set the test-receiver system to Peak Detect Function and specified bandwidth with Maximum Hold Mode.

3.1.4 Test Setup

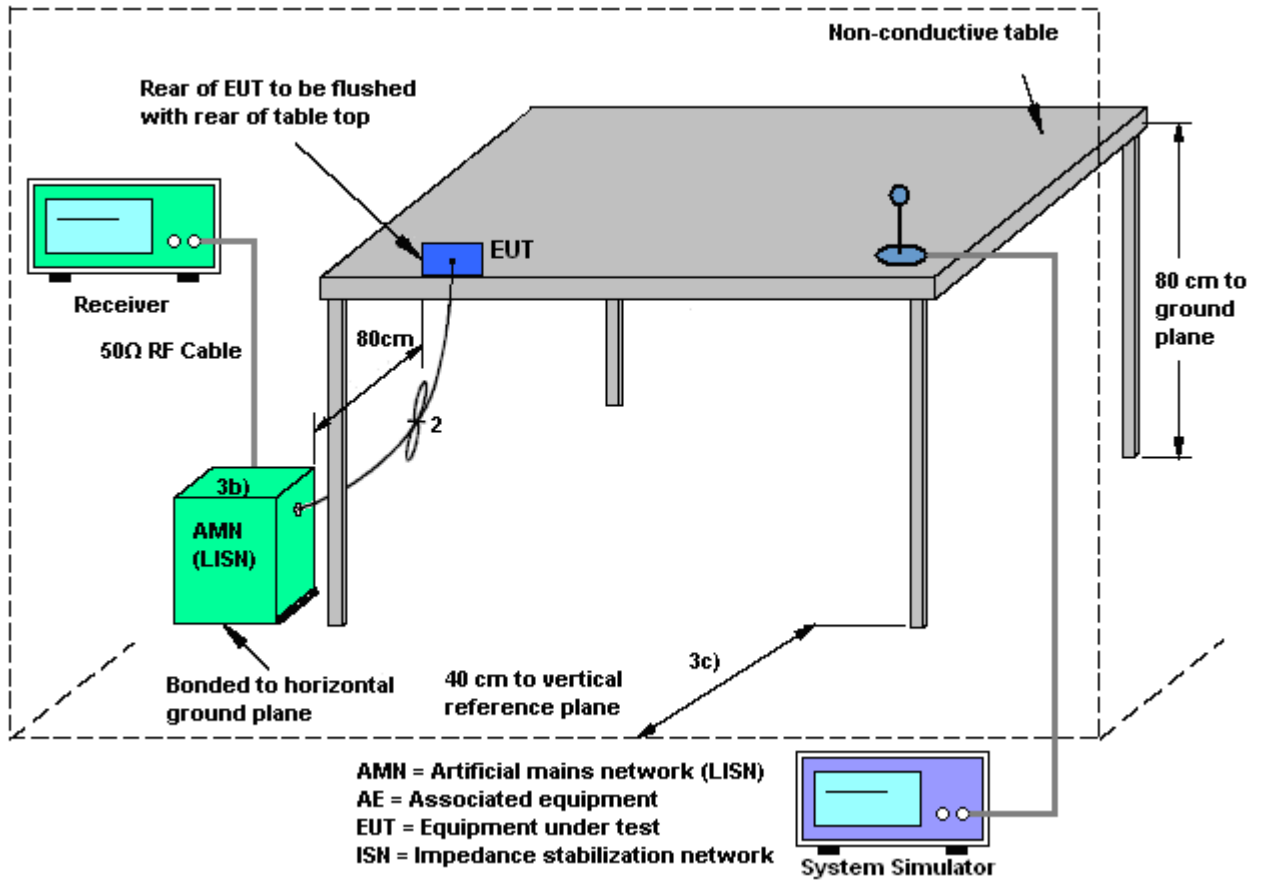



3.1.5 Test Result of AC Conducted Emission

Test Mode :	Mode 1	Temperature :	20~22°C
Test Engineer :	Cosmo Xu	Relative Humidity :	46~48%
Test Voltage :	120Vac / 60Hz	Phase :	Line
Function Type :	GSM850 Idle + Bluetooth Idle + WLAN Idle + Earphone + GPS Rx + Battery + USB Cable (Data Link with Notebook)		

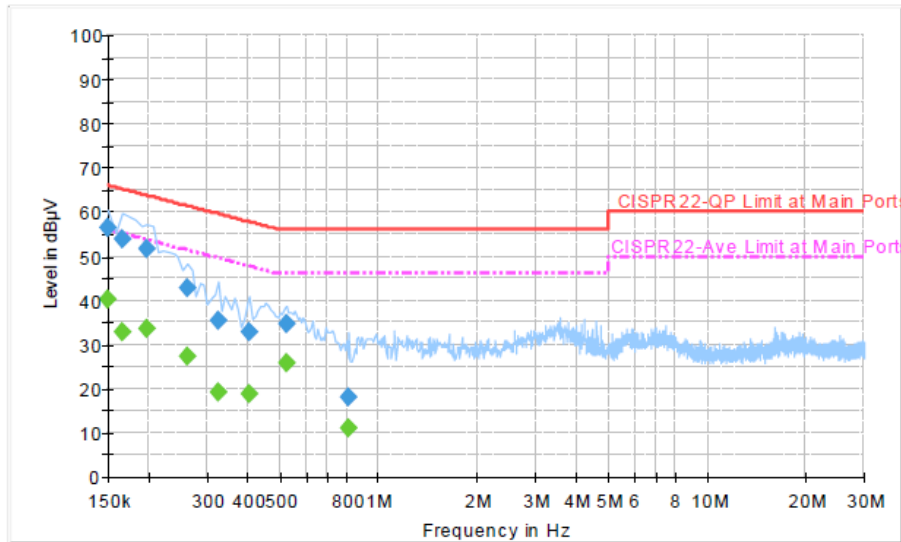

Final Result : Quasi-Peak

Frequency (MHz)	Quasi-Peak (dBµV)	Filter	Line	Corr. (dB)	Margin (dB)	Limit (dBµV)
0.150000	56.3	Off	L1	19.3	9.7	66.0
0.166000	53.7	Off	L1	19.3	11.5	65.2
0.198000	51.7	Off	L1	19.3	12.0	63.7
0.262000	42.8	Off	L1	19.4	18.6	61.4
0.326000	35.6	Off	L1	19.4	24.0	59.6
0.406000	33.0	Off	L1	19.4	24.7	57.7
0.526000	34.7	Off	L1	19.4	21.3	56.0
0.814000	18.1	Off	L1	19.5	37.9	56.0

Final Result : Average

Frequency (MHz)	Average (dBµV)	Filter	Line	Corr. (dB)	Margin (dB)	Limit (dBµV)
0.150000	40.1	Off	L1	19.3	15.9	56.0
0.166000	32.9	Off	L1	19.3	22.3	55.2
0.198000	33.6	Off	L1	19.3	20.1	53.7
0.262000	27.5	Off	L1	19.4	23.9	51.4
0.326000	19.2	Off	L1	19.4	30.4	49.6
0.406000	19.0	Off	L1	19.4	28.7	47.7
0.526000	25.9	Off	L1	19.4	20.1	46.0
0.814000	11.1	Off	L1	19.5	34.9	46.0



Test Mode :	Mode 1	Temperature :	20~22°C
Test Engineer :	Cosmo Xu	Relative Humidity :	46~48%
Test Voltage :	120Vac / 60Hz	Phase :	Neutral
Function Type :	GSM850 Idle + Bluetooth Idle + WLAN Idle + Earphone + GPS Rx + Battery + USB Cable (Data Link with Notebook)		

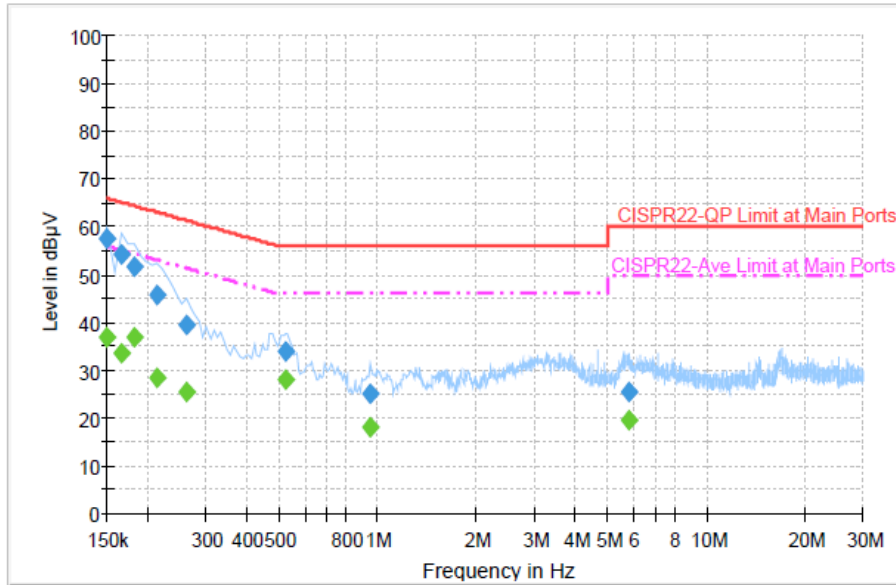

Final Result : Quasi-Peak

Frequency (MHz)	Quasi-Peak (dBµV)	Filter	Line	Corr. (dB)	Margin (dB)	Limit (dBµV)
0.150000	57.6	Off	N	19.4	8.4	66.0
0.166000	54.1	Off	N	19.3	11.1	65.2
0.182000	51.8	Off	N	19.4	12.6	64.4
0.214000	45.7	Off	N	19.4	17.3	63.0
0.262000	39.5	Off	N	19.4	21.9	61.4
0.526000	33.9	Off	N	19.4	22.1	56.0
0.950000	25.0	Off	N	19.5	31.0	56.0
5.846000	25.4	Off	N	19.6	34.6	60.0

Final Result : Average

Frequency (MHz)	Average (dBµV)	Filter	Line	Corr. (dB)	Margin (dB)	Limit (dBµV)
0.150000	37.0	Off	N	19.4	19.0	56.0
0.166000	33.6	Off	N	19.3	21.6	55.2
0.182000	36.9	Off	N	19.4	17.5	54.4
0.214000	28.6	Off	N	19.4	24.4	53.0
0.262000	25.3	Off	N	19.4	26.1	51.4
0.526000	27.9	Off	N	19.4	18.1	46.0
0.950000	18.1	Off	N	19.5	27.9	46.0
5.846000	19.5	Off	N	19.6	30.5	50.0



3.2. Test of Radiated Emission Measurement

3.2.1. Limit of Radiated Emission

The emissions from an unintentional radiator shall not exceed the field strength levels specified in the following table:

Frequency (MHz)	Field Strength (microvolts/meter)	Measurement Distance (meters)
30 – 88	100	3
88 – 216	150	3
216 - 960	200	3
Above 960	500	3



3.2.2. Measuring Instruments

The measuring equipment is listed in the section 4 of this test report.

3.2.3. Test Procedures

1. The EUT was placed on a turntable with 0.8 meter above ground.
2. The EUT was set 3 meters from the interference receiving antenna, which was mounted on the top of a variable height antenna tower.
3. The table was rotated 360 degrees to determine the position of the highest radiation.
4. The antenna is a Bi-Log antenna and its height is adjusted between one to four meters above ground to find the maximum value of the field strength for both horizontal polarization and vertical polarization of the antenna.
5. For each suspected emission, the EUT was arranged to its worst case and then tune the antenna tower (from 1 m to 4 m) and turntable (from 0 degree to 360 degrees) to find the maximum reading.
6. Set the test-receiver system to Peak Detect Function and specified bandwidth with Maximum Hold Mode.
7. If the emission level of the EUT in peak mode was 3 dB lower than the limit specified, peak values of EUT will be reported. Otherwise, the emission will be repeated by using the quasi-peak method and reported.
8. Emission level (dB μ V/m) = 20 log Emission level (μ V/m)
9. Corrected Reading: Antenna Factor + Cable Loss + Read Level - Preamp Factor = Level

3.2.4. Test Setup of Radiated Emission

For radiated emissions from 30MHz to 1GHz

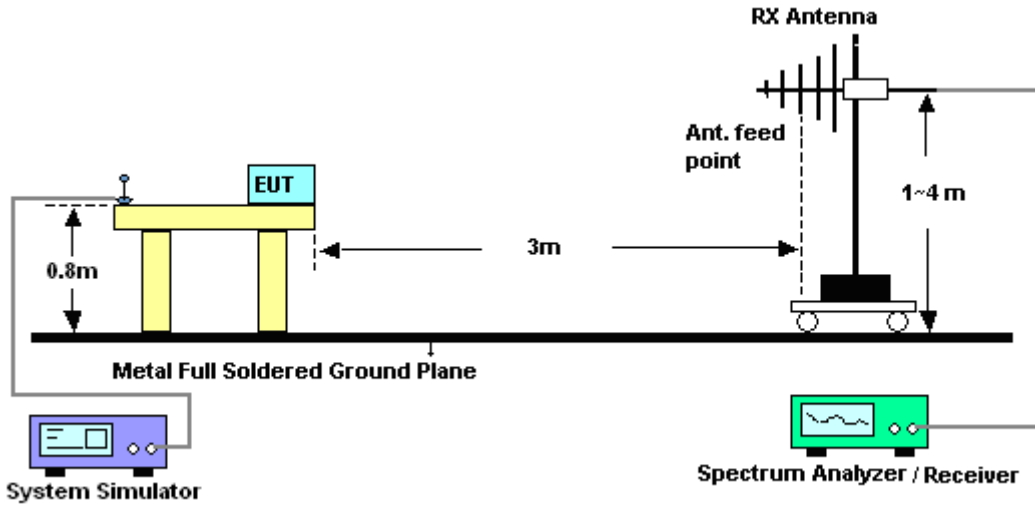

For radiated emissions above 1GHz

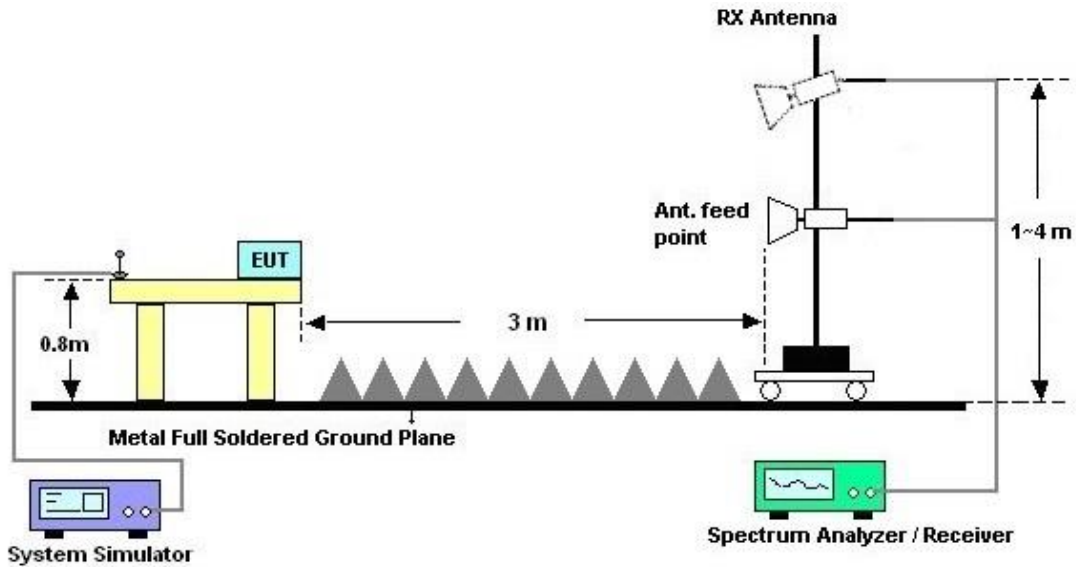



3.2.5. Test Result of Radiated Emission

Test Mode :	Mode 1	Temperature :	22~24°C
Test Engineer :	Abi Lin	Relative Humidity :	47~49%
Test Distance :	3m	Polarization :	Horizontal
Function Type :	GSM850 Idle + Bluetooth Idle + WLAN Idle + Earphone + GPS Rx + Battery + USB Cable (Data Link with Notebook)		
Remark :	#8 is system simulator signal which can be ignored.		

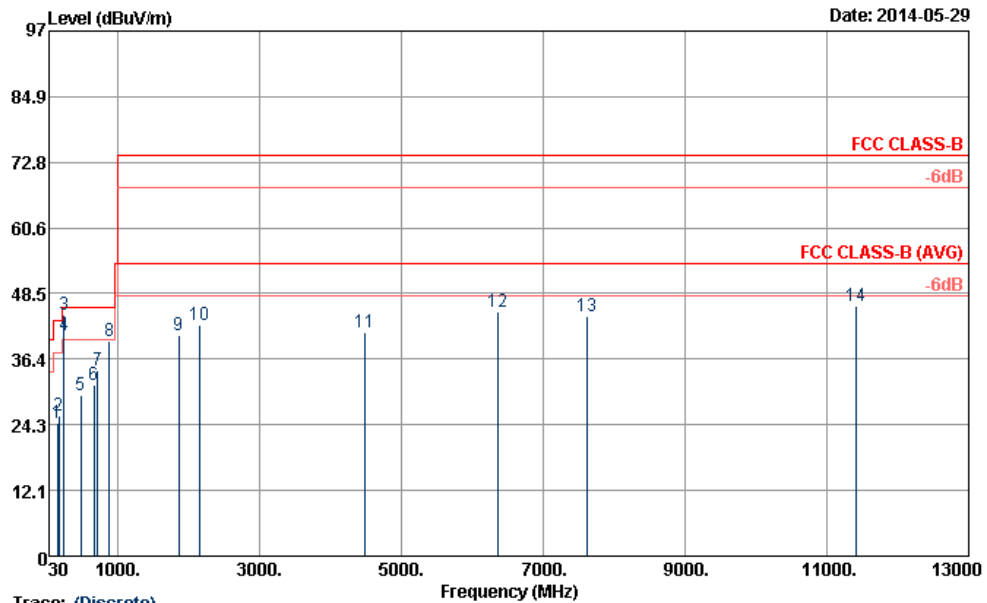

Trace: (Discrete)

Site : 03CH06-HY
 Condition : FCC CLASS-B 3m HF-ANT_583_130802 HORIZONTAL
 Project : 451609
 Power : From System
 Mode : Mode 1

	Freq	Level	Over	Limit	ReadAntenna	Cable	Preamp	A/Pos	T/Pos	Remark
	MHz	dBuV/m	dB	dBuV/m	dBuV	dB	dB	cm	deg	
1	144.75	24.56	-18.94	43.50	44.31	10.68	1.32	31.75	---	Peak
2	169.86	26.01	-17.49	43.50	46.33	9.80	1.63	31.75	---	Peak
3	240.06	44.70	-1.30	46.00	63.26	11.49	1.69	31.74	100	298 Peak
4	240.06	40.70	-5.30	46.00	59.26	11.49	1.69	31.74	100	298 QP
5	479.90	29.69	-16.31	46.00	41.70	17.60	2.30	31.91	---	Peak
6	667.50	31.57	-14.43	46.00	41.30	19.47	2.83	32.03	---	Peak
7	720.00	34.43	-11.57	46.00	43.69	19.80	2.95	32.01	---	Peak
8	881.40	39.66			47.05	20.90	3.32	31.61	---	Peak
9	1856.00	40.73	-33.27	74.00	65.17	30.46	5.57	60.47	---	Peak
10	2144.00	42.63	-31.37	74.00	65.31	31.71	6.11	60.50	---	Peak
11	4494.00	41.26	-32.74	74.00	58.20	34.60	10.06	61.60	---	Peak
12	6368.00	45.16	-28.84	74.00	58.26	35.59	11.73	60.42	---	Peak
13	7626.00	44.38	-29.62	74.00	58.30	35.53	10.91	60.36	---	Peak
14	11404.00	46.26	-27.74	74.00	56.12	37.76	11.00	58.62	100	0 Peak



Test Mode :	Mode 1	Temperature :	22~24°C
Test Engineer :	Abi Lin	Relative Humidity :	47~49%
Test Distance :	3m	Polarization :	Vertical
Function Type :	GSM850 Idle + Bluetooth Idle + WLAN Idle + Earphone + GPS Rx + Battery + USB Cable (Data Link with Notebook)		
Remark :	#7 is system simulator signal which can be ignored.		

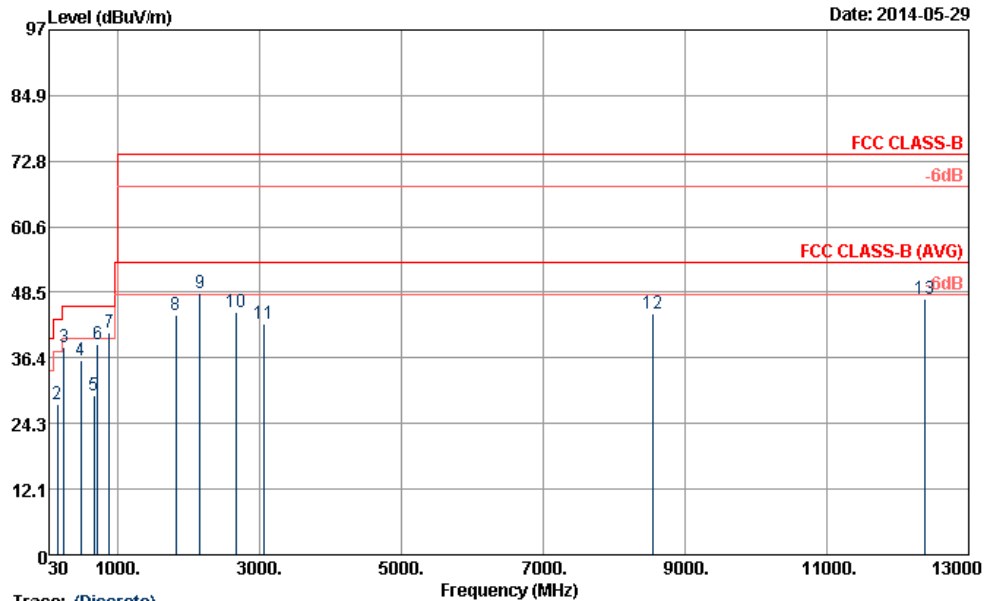

Trace: (Discrete)

Site : 03CH06-HY
 Condition : FCC CLASS-B 3m HF-ANT_583_130802 VERTICAL
 Project : 451609
 Power : From System
 Mode : Mode 1

	Freq	Level	Over Limit	Limit Line	ReadAntenna Level	Cable Preamp Loss	A/Pos	T/Pos	Remark
	MHz	dBUV/m	dB	dBUV/m	dBuV	dB/m	dB	cm	deg
1	30.00	28.90	-11.10	40.00	41.56	18.50	0.64	31.80	---
2	145.56	27.85	-15.65	43.50	47.67	10.60	1.33	31.75	---
3	240.06	38.25	-7.75	46.00	56.81	11.49	1.69	31.74	---
4	479.90	35.85	-10.15	46.00	47.86	17.60	2.30	31.91	---
5	667.50	29.50	-16.50	46.00	39.23	19.47	2.83	32.03	---
6	720.00	38.99	-7.01	46.00	48.25	19.80	2.95	32.01	100 198
7 !	881.40	41.06			48.45	20.90	3.32	31.61	---
8	1822.00	44.35	-29.65	74.00	69.15	30.21	5.45	60.46	---
9	2158.00	48.33	-25.67	74.00	71.00	31.72	6.11	60.50	100 0
10	2666.00	44.77	-29.23	74.00	66.29	32.23	6.92	60.67	---
11	3064.00	42.61	-31.39	74.00	63.29	32.71	7.65	61.04	---
12	8554.00	44.54	-29.46	74.00	57.82	35.64	10.67	59.59	---
13	12380.00	47.40	-26.60	74.00	56.52	39.08	11.36	59.56	---



4. List of Measuring Equipment

Instrument	Manufacturer	Model No.	Serial No.	Characteristics	Calibration Date	Test Date	Due Date	Remark
EMI Test Receiver	Rohde & Schwarz	ESCS 30	100356	9kHz ~ 2.75GHz	Nov. 15, 2013	Jun. 11, 2014	Nov. 14, 2014	Conduction (CO05-HY)
LISN (for auxiliary equipment)	Rohde & Schwarz	ENV216	100081	9kHz ~ 30MHz	Dec. 12, 2013	Jun. 11, 2014	Dec. 11, 2014	Conduction (CO05-HY)
LISN	Rohde & Schwarz	ENV216	100080	9kHz ~ 30MHz	Dec. 04, 2013	Jun. 11, 2014	Dec. 03, 2014	Conduction (CO05-HY)
AC Power Source	ChainTek	APC-1000W	N/A	N/A	N/A	Jun. 11, 2014	N/A	Conduction (CO05-HY)
Spectrum Analyzer	R&S	FSP30	101067	9kHz ~ 30GHz	Nov. 20, 2013	May 29, 2014	Nov. 19, 2014	Radiation (03CH06-HY)
Spectrum Analyzer	Agilent	E4408B	MY44211030	9kHz ~ 26.5GHz	Dec. 02, 2013	May 29, 2014	Dec. 01, 2014	Radiation (03CH06-HY)
EMI Test Receiver	R&S	ESVS10	834468/0003	20MHz ~ 1000MHz	May 06, 2014	May 29, 2014	May 05, 2015	Radiation (03CH06-HY)
Bilog Antenna	Schaffner	CBL6112B	2885	30MHz ~ 2GHz	Oct. 10, 2013	May 29, 2014	Oct. 09, 2014	Radiation (03CH06-HY)
Double Ridge Horn Antenna	EMCO	3117	00066583	1GHz ~ 18GHz	Aug. 02, 2013	May 29, 2014	Aug. 01, 2014	Radiation (03CH06-HY)
Amplifier	SONOMA	310N	186713	9kHz ~ 1GHz	Apr. 16, 2014	May 29, 2014	Apr. 15, 2015	Radiation (03CH06-HY)
Pre Amplifier	EMCI	EMC051845	SN980048	1GHz ~ 18GHz	Jul. 18, 2013	May 29, 2014	Jul. 17, 2014	Radiation (03CH06-HY)
Turn Table	INN-CO	DS2000	420/650/00	0 ~ 360 degree	N/A	May 29, 2014	N/A	Radiation (03CH06-HY)
Antenna Mast	MF	MF-7802	MF78020821 2	1 m ~ 4 m	N/A	May 29, 2014	N/A	Radiation (03CH06-HY)
Loop Antenna	R&S	HFH2-Z2	860004/0001	9kHz ~ 30MHz	Jul. 03, 2012	May 29, 2014	Jul. 02, 2014	Radiation (03CH06-HY)



5. Uncertainty of Evaluation

Uncertainty of Conducted Emission Measurement (150 kHz ~ 30 MHz)

Measuring Uncertainty for a Level of Confidence of 95% ($U = 2Uc(y)$)	2.26
---	------

Uncertainty of Radiated Emission Measurement (30 MHz ~ 1000 MHz)

Measuring Uncertainty for a Level of Confidence of 95% ($U = 2Uc(y)$)	4.50
---	------



Appendix A. Original Report

Please refer to Sporton report number FC442326 as below.



FCC Test Report

APPLICANT : Motorola Mobility, LLC
EQUIPMENT : Mobile Cellular Phone
BRAND NAME : Motorola
MODEL NAME : 4023
FCC ID : IHDT56QB1
STANDARD : FCC 47 CFR FCC Part 15 Subpart B
CLASSIFICATION : Certification

The product was received on Apr. 23, 2014 and testing was completed on Jun. 11, 2014. We, SPORTON INTERNATIONAL INC., would like to declare that the tested sample has been evaluated in accordance with the test procedures given in ANSI C63.4-2009 and has been in compliance with the applicable technical standards.

The test results in this report apply exclusively to the tested model / sample. Without written approval of SPORTON INTERNATIONAL INC., the test report shall not be reproduced except in full.

Reviewed by: Louis Wu / Manager

Approved by: Jones Tsai / Manager



SPORTON INTERNATIONAL INC.

No. 52, Hwa Ya 1st Rd., Hwa Ya Technology Park, Kwei-Shan Hsiang, Tao Yuan Hsien, Taiwan, R.O.C.



TABLE OF CONTENTS

REVISION HISTORY 3

SUMMARY OF TEST RESULT 4

1. GENERAL DESCRIPTION 5

 1.1. Applicant..... 5

 1.2. Manufacturer 5

 1.3. Product Feature of Equipment Under Test 5

 1.4. Product Specification subjective to this standard 6

 1.5. Modification of EUT 6

 1.6. Test Location 7

 1.7. Applicable Standards 7

2. TEST CONFIGURATION OF EQUIPMENT UNDER TEST 8

 2.1. Test Mode 8

 2.2. Connection Diagram of Test System 10

 2.3. Support Unit used in test configuration and system..... 10

 2.4. EUT Operation Test Setup 11

3. TEST RESULT..... 12

 3.1. Test of AC Conducted Emission Measurement 12

 3.2. Test of Radiated Emission Measurement 16

4. LIST OF MEASURING EQUIPMENT 21

5. UNCERTAINTY OF EVALUATION 22



SUMMARY OF TEST RESULT

Report Section	FCC Rule	Description	Limit	Result	Remark
3.1	15.107	AC Conducted Emission	< 15.107 limits	PASS	Under limit 8.50 dB at 0.158 MHz
3.2	15.109	Radiated Emission	< 15.109 limits	PASS	Under limit 4.35 dB at 240.060 MHz



1. General Description

1.1. Applicant

Motorola Mobility, LLC

222 W Merchandise Mart Plaza, Suite 1800, Chicago, IL 60654, United States

1.2. Manufacturer

Motorola Mobility, LLC

222 W Merchandise Mart Plaza, Suite 1800, Chicago, IL 60654, United States

1.3. Product Feature of Equipment Under Test

Product Feature	
Equipment	Mobile Cellular Phone
Brand Name	Motorola
Model Name	4023
FCC ID	IHDT56QB1
IMEI	359286050063637
EUT supports Radios application	GSM/EGPRS/WCDMA/HSPA WLAN 11b/g/n HT20 Bluetooth v2.1 EDR Bluetooth v4.0 - LE
HW Version	P2
SW Version	KXB21.23.66
EUT Stage	Identical Prototype

Remark: The above EUT's information was declared by manufacturer. Please refer to the specifications or user's manual for more detailed description.

Accessory List	
USB Cable	Brand Name : Foxlink
	Model Name : 6691-10FL-0387
Earphone	Brand Name : MOTOROLA
	Model Name : SJYN1181B



1.4. Product Specification subjective to this standard

Product Specification subjective to this standard	
Tx Frequency	GSM850 : 824.2 MHz ~ 848.8 MHz GSM1900 : 1850.2 MHz ~ 1909.8MHz WCDMA Band V : 826.4 MHz ~ 846.6 MHz WCDMA Band II : 1852.4 MHz ~ 1907.6 MHz 802.11b/g/n: 2412 MHz ~ 2462 MHz Bluetooth: 2402 MHz ~ 2480 MHz
Rx Frequency	GSM850 : 869.2 MHz ~ 893.8 MHz GSM1900 : 1930.2 MHz ~ 1989.8 MHz WCDMA Band V : 871.4 MHz ~ 891.6 MHz WCDMA Band II : 1932.4 MHz ~ 1987.6 MHz 802.11b/g/n: 2412 MHz ~ 2462 MHz Bluetooth: 2402 MHz ~ 2480 MHz GPS : 1.57542 GHz
Antenna Type	WWAN : PIFA Antenna WLAN : PIFA Antenna Bluetooth : PIFA Antenna GPS : PIFA Antenna
Type of Modulation	GSM: GMSK GPRS: GMSK EDGE(MCS 0-4): GMSK / (MCS 5-9): 8PSK WCDMA: QPSK (Uplink) HSDPA: 16QAM (Downlink) HSUPA: QPSK (Uplink) 802.11b : DSSS (DBPSK / DQPSK / CCK) 802.11g/n : OFDM (BPSK / QPSK / 16QAM / 64QAM) Bluetooth LE : GFSK Bluetooth (1Mbps) : GFSK Bluetooth (2Mbps) :π /4-DQPSK Bluetooth (3Mbps) : 8-DPSK GPS : BPSK

1.5. Modification of EUT

No modifications are made to the EUT during all test items.



1.6. Test Location

Sporton Lab is accredited to ISO 17025 by Taiwan Accreditation Foundation (TAF code : 1190) and the FCC designation TW1022 under the FCC 2.948(e) by Mutual Recognition Agreement (MRA) in FCC Test.

Test Site	SPORTON INTERNATIONAL INC.	
Test Site Location	No. 52, Hwa Ya 1 st Rd., Hwa Ya Technology Park, Kwei-Shan Hsiang, Tao Yuan Hsien, Taiwan, R.O.C. TEL: +886-3-327-3456 FAX: +886-3-328-4978	
Test Site No.	Sporton Site No.	
	CO05-HY	03CH06-HY

1.7. Applicable Standards

According to the specifications of the manufacturer, the EUT must comply with the requirements of the following standards:

- FCC 47 CFR FCC Part 15 Subpart B
- ANSI C63.4-2009

Remark:

1. All test items were verified and recorded according to the standards and without any deviation during the test.
2. For FCC 15 Subpart B - Unintentional Radiators, device supports FM Radio (Receiver) shall be authorized as "FM broadcast receiver" per the Section 15.101 (a) Equipment authorization of unintentional radiators.
3. For other Unintentional Radiators features of this EUT, test reports are issued separately. Per the Note of the Section 15.101, when device supports features (USB, FM Radio, digital devices...etc.) more than one category of authorization, type of authorization shall be appropriately chosen for FCC 15B compliance rule, and the Section 15.101 (b), only those receivers that operate (tune) within the frequency range of 30-960 MHz, CB receivers and radar detectors are subject to the authorizations shown in paragraph (a) of the Section 15.101. However, receivers indicated as being subject to Declaration of Conformity that are contained within a transceiver, the transmitter portion of which is subject to certification, shall be authorized under the verification procedure



2. Test Configuration of Equipment Under Test

2.1. Test Mode

The EUT has been associated with peripherals pursuant to ANSI C63.4-2009 and configuration operated in a manner tended to maximize its emission characteristics in a typical application.

Frequency range investigated: conduction (150 kHz to 30 MHz), radiation (30MHz to the 5th harmonic of the highest fundamental frequency or to 40 GHz, whichever is lower).

The following tables are showing the test modes as the worst cases and recorded in this report.

Item	EUT Configuration	Test Condition		
		EMI AC	EMI RE<1G	EMI RE≥1G
1.	Data application transferred mode (EUT with notebook)	<input checked="" type="checkbox"/>	<input checked="" type="checkbox"/>	<input checked="" type="checkbox"/>

Abbreviations:

- EMI AC: AC conducted emissions
- EMI RE ≥ 1G: EUT radiated emissions ≥ 1GHz
- EMI RE < 1G: EUT radiated emissions < 1GHz



Test Items	EUT Configure Mode	Function Type
AC Conducted Emission	1	Mode 1: GSM850 Idle + Bluetooth Idle + WLAN Idle + Earphone + GPS Rx + Battery + USB Cable (Data Link with Notebook) + SIM 1 Mode 2: WCDMA Band II Idle + Bluetooth Idle + WLAN Idle + Earphone + GPS Rx + Battery + USB Cable (Data Link with Notebook) + SIM 1 Mode 3: GSM850 Idle + Bluetooth Idle + WLAN Idle + Earphone + GPS Rx + Battery + USB Cable (Data Link with Notebook) + SIM 2
Radiated Emissions < 1GHz	1	Mode 1: GSM850 Idle + Bluetooth Idle + WLAN Idle + Earphone + GPS Rx + Battery + USB Cable (Data Link with Notebook) + SIM 1 Mode 2: WCDMA Band II Idle + Bluetooth Idle + WLAN Idle + Earphone + GPS Rx + Battery + USB Cable (Data Link with Notebook) + SIM 1 Mode 3: GSM850 Idle + Bluetooth Idle + WLAN Idle + Earphone + GPS Rx + Battery + USB Cable (Data Link with Notebook) + SIM 2
Radiated Emissions ≥ 1GHz	1	Mode 1: GSM850 Idle + Bluetooth Idle + WLAN Idle + Earphone + GPS Rx + Battery + USB Cable (Data Link with Notebook) + SIM 2

Remark:

1. The worst case of AC is mode 1; only the test data of this mode was reported.
2. The worst case of RE < 1G is mode 3; only the test data of this mode was reported.
3. Data Link with Notebook means data application transferred mode between EUT and Notebook.

2.2. Connection Diagram of Test System

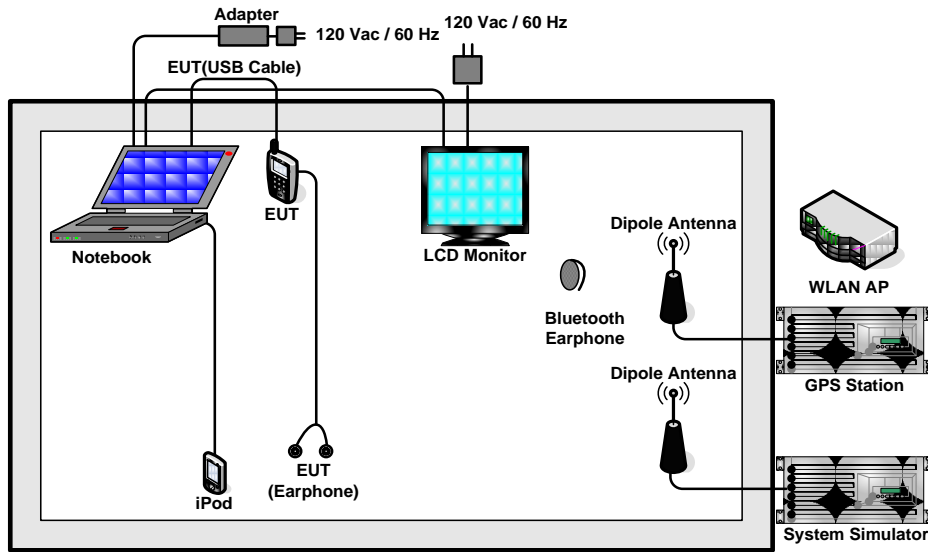

2.3. Support Unit used in test configuration and system

Item	Equipment	Trade Name	Model Name	FCC ID	Data Cable	Power Cord
1.	System Simulator	R&S	CMU 200	N/A	N/A	Unshielded, 1.8 m
2.	GPS Station	T&E	GS-50	N/A	N/A	Unshielded, 1.8 m
3.	GPS Station	Pendulum	GSG-54	N/A	N/A	Unshielded, 1.8 m
4.	WLAN AP	D-Link	DIR-628	KA2DIR628A2	N/A	Unshielded, 1.8 m
5.	Notebook	DELL	Latitude E6320	FCC DoC/ Contains FCC ID: QDS-BRCM1054	N/A	AC I/P: Unshielded, 1.2 m DC O/P: Shielded, 1.8 m
6.	Bluetooth Earphone	Sony Ericsson	MW600	PY7DDA-2029	N/A	N/A
7.	LCD Monitor	DELL	U2410	FCC DoC	Shielded, 1.6 m	Unshielded, 1.8 m
8.	iPod	Apple	A1285	FCC DoC	Shielded, 1.0 m	N/A



2.4. EUT Operation Test Setup

The EUT was in GSM and WCDMA idle mode during the testing. The EUT was synchronized to the BCCH, and was in continuous receiving mode by setting system simulator's paging reorganization.

At the same time, the EUT was attached to the Bluetooth earphone or WLAN AP, and the following programs installed in the EUT were programmed during the test.

1. Data application is transferred between Laptop and EUT via USB cable.
2. Execute "GPS Test" to make the EUT continuously receive signals from GPS station.



3. Test Result

3.1. Test of AC Conducted Emission Measurement

3.1.1 Limits of AC Conducted Emission

For equipment that is designed to be connected to the public utility (AC) power line, the radio frequency voltage that is conducted back onto the AC power line on any frequency or frequencies within the band 150 kHz to 30 MHz shall not exceed the limits in the following table.

Frequency of emission (MHz)	Conducted limit (dBuV)	
	Quasi-peak	Average
0.15-0.5	66 to 56*	56 to 46*
0.5-5	56	46
5-30	60	50

*Decreases with the logarithm of the frequency.

3.1.2 Measuring Instruments

The measuring equipment is listed in the section 4 of this test report.

3.1.3 Test Procedure

1. The EUT was placed 0.4 meter from the conducting wall of the shielding room was kept at least 80 centimeters from any other grounded conducting surface.
2. Connect EUT to the power mains through a line impedance stabilization network (LISN).
3. All the support units are connecting to the other LISN.
4. The LISN provides 50 ohm coupling impedance for the measuring instrument.
5. The FCC states that a 50 ohm, 50 microhenry LISN should be used.
6. Both sides of AC line were checked for maximum conducted interference.
7. The frequency range from 150 kHz to 30 MHz was searched.
8. Set the test-receiver system to Peak Detect Function and specified bandwidth with Maximum Hold Mode.

3.1.4 Test Setup

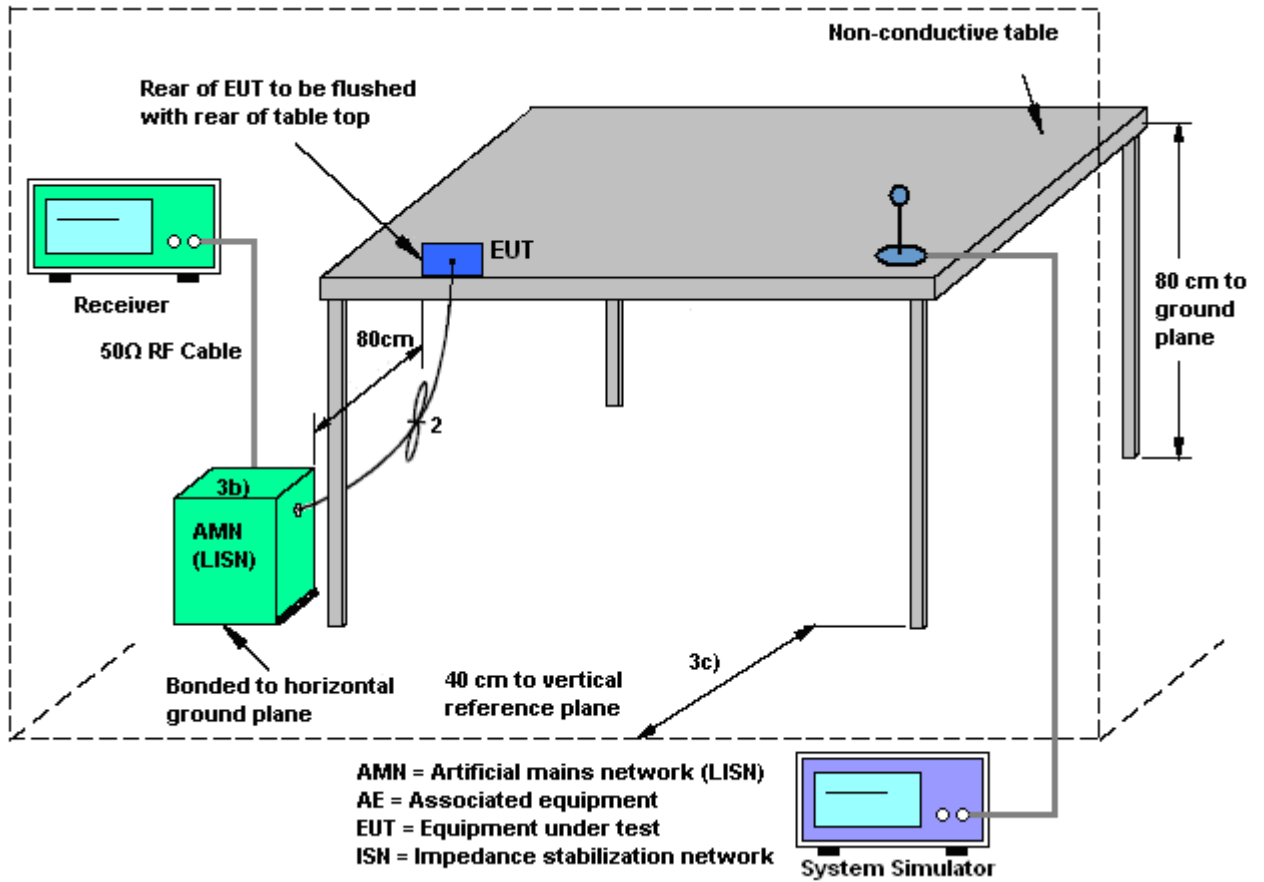



3.1.5 Test Result of AC Conducted Emission

Test Mode :	Mode 1	Temperature :	20~22°C
Test Engineer :	Cosmo Xu	Relative Humidity :	45~47%
Test Voltage :	120Vac / 60Hz	Phase :	Line
Function Type :	GSM850 Idle + Bluetooth Idle + WLAN Idle + Earphone + GPS Rx + Battery + USB Cable (Data Link with Notebook) + SIM 1		

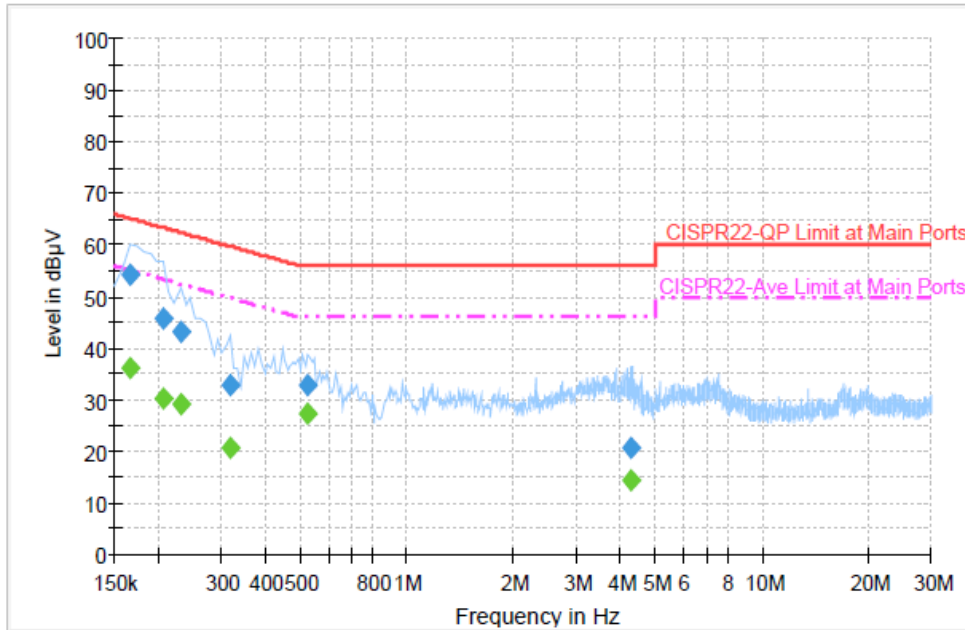

Final Result : Quasi-Peak

Frequency (MHz)	Quasi-Peak (dBµV)	Filter	Line	Corr. (dB)	Margin (dB)	Limit (dBµV)
0.166000	54.2	Off	L1	19.3	11.0	65.2
0.206000	45.7	Off	L1	19.3	17.7	63.4
0.230000	43.3	Off	L1	19.4	19.1	62.4
0.318000	32.8	Off	L1	19.4	27.0	59.8
0.526000	32.9	Off	L1	19.4	23.1	56.0
4.254000	20.7	Off	L1	19.6	35.3	56.0

Final Result : Average

Frequency (MHz)	Average (dBµV)	Filter	Line	Corr. (dB)	Margin (dB)	Limit (dBµV)
0.166000	36.3	Off	L1	19.3	18.9	55.2
0.206000	30.2	Off	L1	19.3	23.2	53.4
0.230000	29.0	Off	L1	19.4	23.4	52.4
0.318000	20.5	Off	L1	19.4	29.3	49.8
0.526000	27.5	Off	L1	19.4	18.5	46.0
4.254000	14.4	Off	L1	19.6	31.6	46.0



Test Mode :	Mode 1	Temperature :	20~22°C
Test Engineer :	Cosmo Xu	Relative Humidity :	45~47%
Test Voltage :	120Vac / 60Hz	Phase :	Neutral
Function Type :	GSM850 Idle + Bluetooth Idle + WLAN Idle + Earphone + GPS Rx + Battery + USB Cable (Data Link with Notebook) + SIM 1		

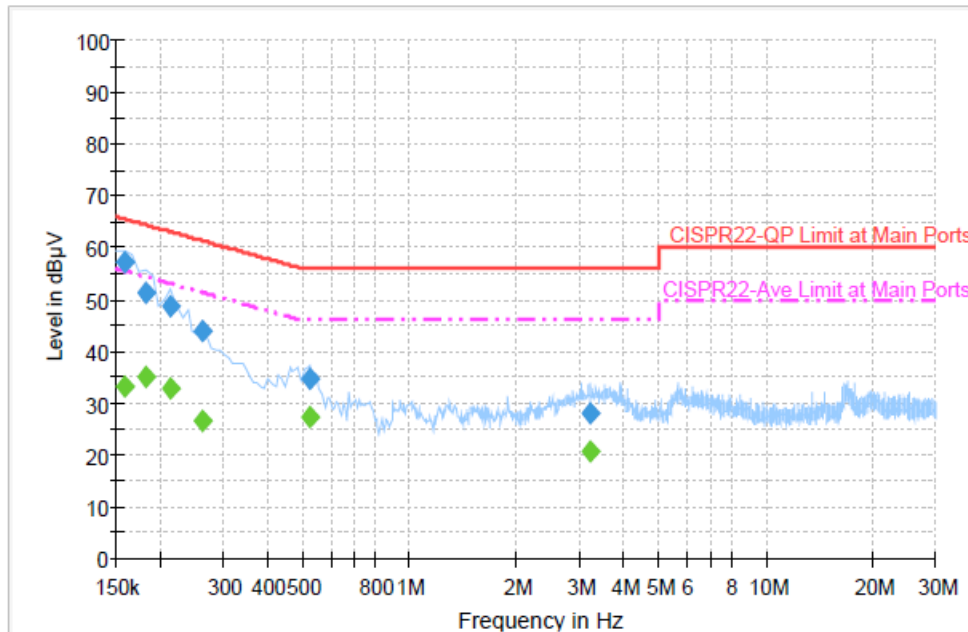

Final Result : Quasi-Peak

Frequency (MHz)	Quasi-Peak (dBµV)	Filter	Line	Corr. (dB)	Margin (dB)	Limit (dBµV)
0.158000	57.1	Off	N	19.4	8.5	65.6
0.182000	51.3	Off	N	19.4	13.1	64.4
0.214000	48.7	Off	N	19.4	14.3	63.0
0.262000	43.8	Off	N	19.4	17.6	61.4
0.526000	34.5	Off	N	19.4	21.5	56.0
3.222000	27.9	Off	N	19.6	28.1	56.0

Final Result : Average

Frequency (MHz)	Average (dBµV)	Filter	Line	Corr. (dB)	Margin (dB)	Limit (dBµV)
0.158000	33.2	Off	N	19.4	22.4	55.6
0.182000	35.1	Off	N	19.4	19.3	54.4
0.214000	32.8	Off	N	19.4	20.2	53.0
0.262000	26.4	Off	N	19.4	25.0	51.4
0.526000	27.2	Off	N	19.4	18.8	46.0
3.222000	20.7	Off	N	19.6	25.3	46.0



3.2. Test of Radiated Emission Measurement

3.2.1. Limit of Radiated Emission

The emissions from an unintentional radiator shall not exceed the field strength levels specified in the following table:

Frequency (MHz)	Field Strength (microvolts/meter)	Measurement Distance (meters)
30 – 88	100	3
88 – 216	150	3
216 - 960	200	3
Above 960	500	3



3.2.2. Measuring Instruments

The measuring equipment is listed in the section 4 of this test report.

3.2.3. Test Procedures

1. The EUT was placed on a turntable with 0.8 meter above ground.
2. The EUT was set 3 meters from the interference receiving antenna, which was mounted on the top of a variable height antenna tower.
3. The table was rotated 360 degrees to determine the position of the highest radiation.
4. The antenna is a Bi-Log antenna and its height is adjusted between one to four meters above ground to find the maximum value of the field strength for both horizontal polarization and vertical polarization of the antenna.
5. For each suspected emission, the EUT was arranged to its worst case and then tune the antenna tower (from 1 m to 4 m) and turntable (from 0 degree to 360 degrees) to find the maximum reading.
6. Set the test-receiver system to Peak Detect Function and specified bandwidth with Maximum Hold Mode.
7. If the emission level of the EUT in peak mode was 3 dB lower than the limit specified, peak values of EUT will be reported. Otherwise, the emission will be repeated by using the quasi-peak method and reported.
8. Emission level (dB μ V/m) = 20 log Emission level (μ V/m)
9. Corrected Reading: Antenna Factor + Cable Loss + Read Level - Preamp Factor = Level

3.2.4. Test Setup of Radiated Emission

For radiated emissions from 30MHz to 1GHz

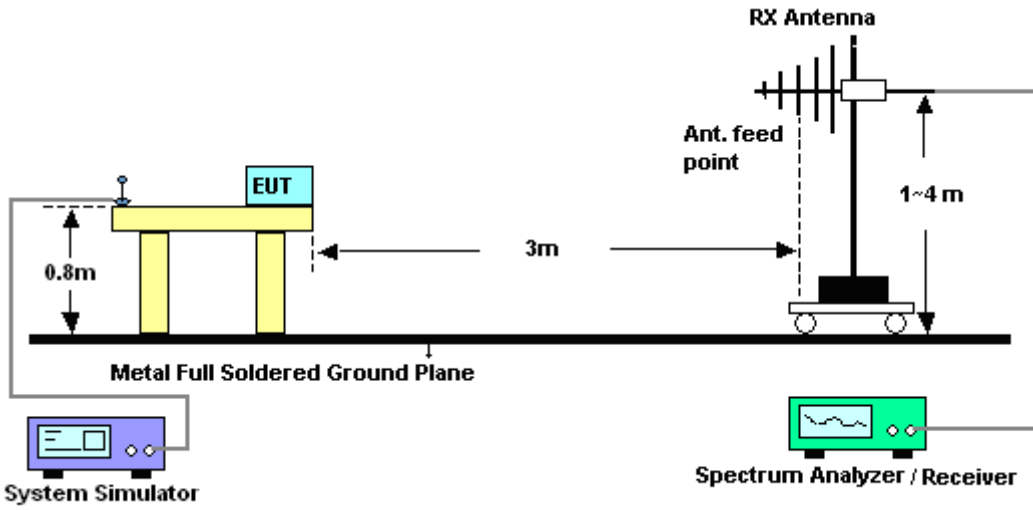

For radiated emissions above 1GHz

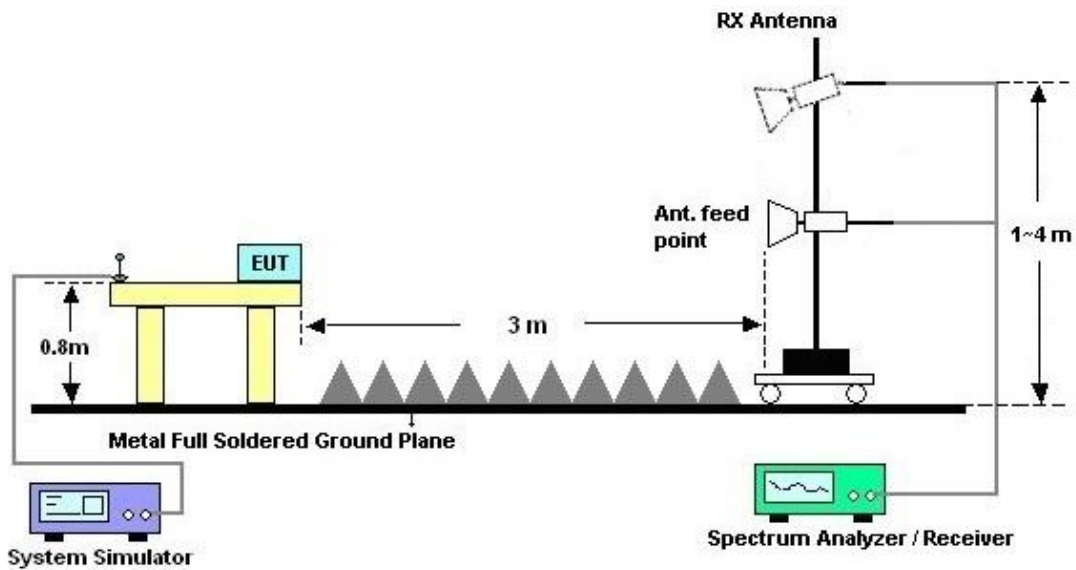



3.2.5. Test Result of Radiated Emission

Test Mode :	Mode 3	Temperature :	23~24°C
Test Engineer :	Gavin Wu	Relative Humidity :	45~46%
Test Distance :	3m	Polarization :	Horizontal
Function Type :	GSM850 Idle + Bluetooth Idle + WLAN Idle + Earphone + GPS Rx + Battery + USB Cable (Data Link with Notebook) + SIM 2		
Remark :	#7 is system simulator signal which can be ignored.		

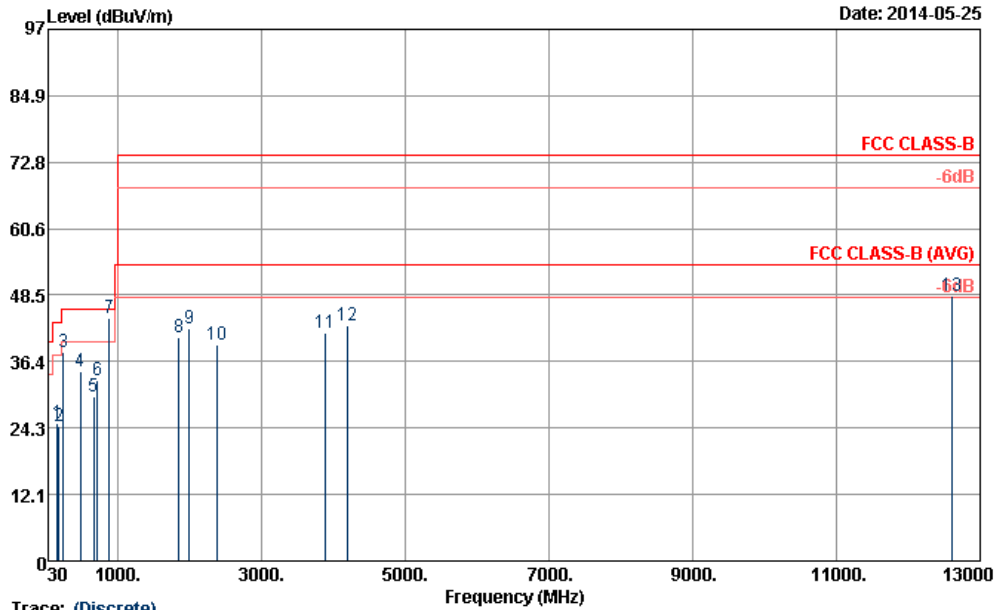

Trace: (Discrete)
 Site : 03CH06-HY
 Condition : FCC CLASS-B 3m HF-ANT_583_130802 HORIZONTAL
 Project : 442326
 Power : 120Vac/60Hz
 Mode : Mode 3

	Freq	Level	Over Limit	Limit Line	ReadAntenna Level	Antenna Factor	Cable Loss	Preamp Factor	A/Pos	T/Pos	Remark
	MHz	dBuV/m	dB	dBuV/m	dBuV	dB/m	dB	dB	cm	deg	
1	154.20	25.17	-18.33	43.50	45.23	10.30	1.39	31.75	---	---	Peak
2	183.36	24.50	-19.00	43.50	45.67	9.12	1.46	31.75	---	---	Peak
3	240.06	37.99	-8.01	46.00	56.55	11.49	1.69	31.74	103	229	Peak
4	480.00	34.56	-11.44	46.00	46.63	17.52	2.31	31.90	---	---	Peak
5	665.40	30.01	-15.99	46.00	39.76	19.45	2.83	32.03	---	---	Peak
6	720.00	32.99	-13.01	46.00	42.25	19.80	2.95	32.01	---	---	Peak
7	881.40	44.44			51.83	20.90	3.32	31.61	---	---	Peak
8	1852.00	40.86	-33.14	74.00	65.30	30.46	5.57	60.47	---	---	Peak
9	1994.00	42.51	-31.49	74.00	65.70	31.47	5.84	60.50	---	---	Peak
10	2390.00	39.47	-34.53	74.00	61.60	31.92	6.45	60.50	---	---	Peak
11	3882.00	41.55	-32.45	74.00	61.19	33.28	8.72	61.64	---	---	Peak
12	4186.00	42.97	-31.03	74.00	61.43	33.84	9.36	61.66	---	---	Peak
13	12600.00	48.26	-25.74	74.00	57.56	39.20	11.38	59.88	100	0	Peak



Test Mode :	Mode 3	Temperature :	23~24°C
Test Engineer :	Gavin Wu	Relative Humidity :	45~46%
Test Distance :	3m	Polarization :	Vertical
Function Type :	GSM850 Idle + Bluetooth Idle + WLAN Idle + Earphone + GPS Rx + Battery + USB Cable (Data Link with Notebook) + SIM 2		
Remark :	#7is system simulator signal which can be ignored.		

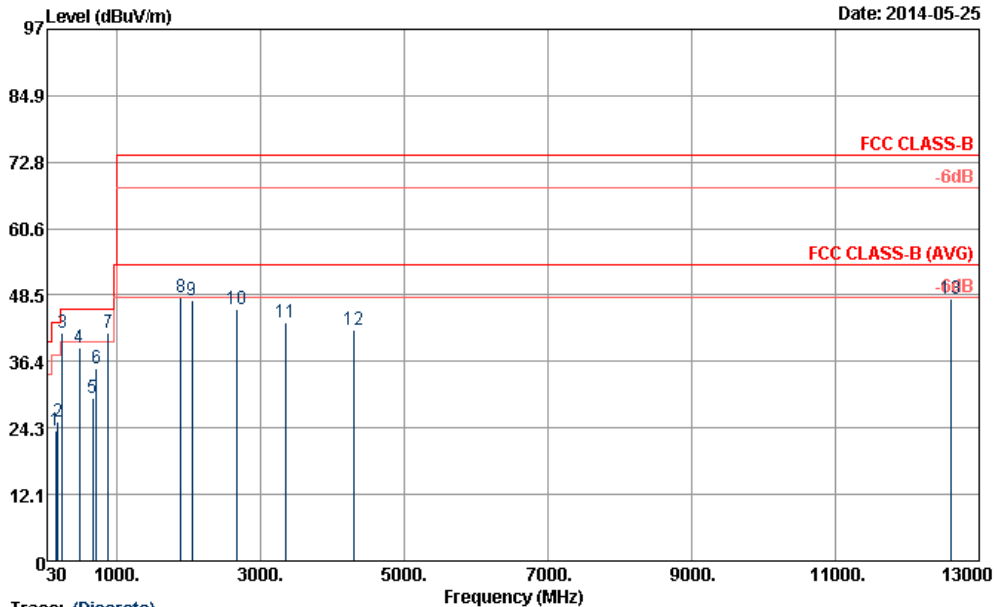

Trace: (Discrete)

Site : 03CH06-HY
 Condition : FCC CLASS-B 3m HF-ANT_583_130802 VERTICAL
 Project : 442326
 Power : 120Vac/60Hz
 Mode : Mode 3

	Freq	Level	Over	Limit	ReadAntenna	Cable	Preamp	A/Pos	T/Pos	Remark	
	MHz	dBuV/m	dB	dBuV/m	dBuV	dB/m	dB	dB	cm	deg	
1	152.85	23.69	-19.81	43.50	43.66	10.40	1.38	31.75	---	---	Peak
2	181.74	25.30	-18.20	43.50	46.36	9.24	1.45	31.75	---	---	Peak
3	240.06	41.65	-4.35	46.00	60.21	11.49	1.69	31.74	100	---	148 Peak
4	480.00	39.02	-6.98	46.00	50.99	17.62	2.32	31.91	---	---	Peak
5	665.40	29.72	-16.28	46.00	39.47	19.45	2.83	32.03	---	---	Peak
6	720.00	35.15	-10.85	46.00	44.41	19.80	2.95	32.01	---	---	Peak
7	881.40	41.61			49.00	20.90	3.32	31.61	---	---	Peak
8	1890.00	48.09	-25.91	74.00	72.24	30.71	5.62	60.48	100	0	Peak
9	2044.00	47.53	-26.47	74.00	70.43	31.63	5.97	60.50	---	---	Peak
10	2666.00	45.86	-28.14	74.00	67.38	32.23	6.92	60.67	---	---	Peak
11	3348.00	43.46	-30.54	74.00	64.07	32.77	7.90	61.28	---	---	Peak
12	4308.00	42.26	-31.74	74.00	60.11	34.16	9.63	61.64	---	---	Peak
13	12600.00	47.91	-26.09	74.00	57.21	39.20	11.38	59.88	---	---	Peak



4. List of Measuring Equipment

Instrument	Manufacturer	Model No.	Serial No.	Characteristics	Calibration Date	Test Date	Due Date	Remark
EMI Test Receiver	Rohde & Schwarz	ESCS 30	100356	9kHz ~ 2.75GHz	Nov. 15, 2013	Jun. 11, 2014	Nov. 14, 2014	Conduction (CO05-HY)
LISN (for auxiliary equipment)	Rohde & Schwarz	ENV216	100081	9kHz ~ 30MHz	Dec. 12, 2013	Jun. 11, 2014	Dec. 11, 2014	Conduction (CO05-HY)
LISN	Rohde & Schwarz	ENV216	100080	9kHz ~ 30MHz	Dec. 04, 2013	Jun. 11, 2014	Dec. 03, 2014	Conduction (CO05-HY)
AC Power Source	ChainTek	APC-1000W	N/A	N/A	N/A	Jun. 11, 2014	N/A	Conduction (CO05-HY)
Spectrum Analyzer	R&S	FSP30	101067	9kHz ~ 30GHz	Nov. 20, 2013	May 25, 2014	Nov. 19, 2014	Radiation (03CH06-HY)
Spectrum Analyzer	Agilent	E4408B	MY44211030	9kHz ~ 26.5GHz	Dec. 02, 2013	May 25, 2014	Dec. 01, 2014	Radiation (03CH06-HY)
EMI Test Receiver	R&S	ESVS10	834468/0003	20MHz ~ 1000MHz	May 06, 2014	May 25, 2014	May 05, 2015	Radiation (03CH06-HY)
Bilog Antenna	Schaffner	CBL6112B	2885	30MHz ~ 2GHz	Oct. 10, 2013	May 25, 2014	Oct. 09, 2014	Radiation (03CH06-HY)
Double Ridge Horn Antenna	EMCO	3117	00066583	1GHz ~ 18GHz	Aug. 02, 2013	May 25, 2014	Aug. 01, 2014	Radiation (03CH06-HY)
Amplifier	SONOMA	310N	186713	9kHz ~ 1GHz	Apr. 16, 2014	May 25, 2014	Apr. 15, 2015	Radiation (03CH06-HY)
Pre Amplifier	EMCI	EMC051845	SN980048	1GHz ~ 18GHz	Jul. 18, 2013	May 25, 2014	Jul. 17, 2014	Radiation (03CH06-HY)
Loop Antenna	Rohde & Schwarz	HFH2-Z2	860004/0001	9kHz ~ 30MHz	Jul. 03, 2012	May 25, 2014	Jul. 02, 2014	Radiation (03CH06-HY)
Turn Table	INN-CO	DS2000	420/650/00	0 ~ 360 degree	N/A	May 25, 2014	N/A	Radiation (03CH06-HY)
Antenna Mast	MF	MF-7802	MF78020821 2	1 m ~ 4 m	N/A	May 25, 2014	N/A	Radiation (03CH06-HY)



5. Uncertainty of Evaluation

Uncertainty of Conducted Emission Measurement (150 kHz ~ 30 MHz)

Measuring Uncertainty for a Level of Confidence of 95% ($U = 2Uc(y)$)	2.26
---	------

Uncertainty of Radiated Emission Measurement (30 MHz ~ 1000 MHz)

Measuring Uncertainty for a Level of Confidence of 95% ($U = 2Uc(y)$)	4.50
---	------