

FCC RF Test Report

APPLICANT : Motorola Mobility, LLC
EQUIPMENT : Mobile Cellular Phone
BRAND NAME : Motorola Mobility, LLC
FCC MODEL NAME : 3578
FCC ID : IHDT56QA1
STANDARD : FCC Part 15 Subpart C §15.225
CLASSIFICATION : (DXX) Low Power Communication Device Transmitt

The product was received on Apr. 29, 2014 and testing was completed on Jun. 17, 2014. We, SPORTON INTERNATIONAL INC., would like to declare that the tested sample has been evaluated in accordance with the test procedures and has been in compliance with the applicable technical standards.

The test results in this report apply exclusively to the tested model / sample. Without written approval of SPORTON INTERNATIONAL INC., the test report shall not be reproduced except in full.



Reviewed by: Joseph Lin / Supervisor

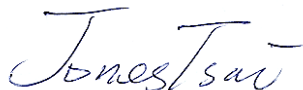

Approved by: Jones Tsai / Manager



SPORTON INTERNATIONAL INC.

No. 52, Hwa Ya 1st Rd., Hwa Ya Technology Park, Kwei-Shan Hsiang, Tao Yuan Hsien, Taiwan, R.O.C.



Table of Contents

1. SUMMARY OF THE TEST RESULT 4
2. GENERAL INFORMATION..... 5
2.1 Applicant..... 5
2.2 Manufacturer..... 5
2.3 Feature of Equipment Under Test 5
2.4 Product Specification of Equipment Under Test 6
2.5 Modification of EUT 6
2.6 Testing Location..... 6
2.7 Applicable Standards..... 7
2.8 Test Modes..... 7
2.9 Test Configurations 8
2.10 Table for Supporting Units..... 9
3. CONDUCTED EMISSION TEST..... 10
3.1 Measuring Instruments 10
3.2 Test setup 10
3.3 Test Result of Conducted Emission Test 10
3.4 AC Power Line Conducted Emissions Measurement..... 11
4. CONDUCTED TEST ITEMS 12
4.1 Measuring Instruments 12
4.2 Test Setup 12
4.3 Test Result of Conducted Test Items 12
4.4 20dB Spectrum Bandwidth Measurement 13
4.5 Frequency Stability Measurement 13
5. RADIATED TEST ITEMS..... 14
5.1 Measuring Instruments 14
5.2 Test Setup 14
5.3 Test Result of Radiated Test Items..... 14
5.4 Field Strength of Fundamental Emissions and Mask Measurement 15
5.5 Radiated Emissions Measurement..... 16
6. LIST OF MEASURING EQUIPMENT 18
APPENDIX A. TEST RESULTS OF CONDUCTED EMISSION TEST
APPENDIX B. TEST RESULTS OF CONDUCTED TEST ITEMS
B.1. Test Result of 20dB Spectrum Bandwidth
B.2 Test Result of Frequency Stability
APPENDIX C. TEST RESULTS OF RADIATED TEST ITEMS
C.1 Test Result of Field Strength of Fundamental Emissions
C.2 Results of Radiated Emissions (9 kHz~30MHz)
C.3 Results of Radiated Emissions (30MHz~1GHz)



1. SUMMARY OF THE TEST RESULT

Applied Standard: 47 CFR FCC Part 15 Subpart C				
Part	FCC Rule	Description of Test	Result	Under Limit
3.1	15.207	AC Power Line Conducted Emissions	Complies	5.40 dB at 13.558MHz
3.2	15.225(a)(b)(c)	Field Strength of Fundamental Emissions	Complies	65.36 dB at 13.560 MHz
3.3	2.1049	20dB Spectrum Bandwidth	Complies	-
3.4	15.225(d) 15.209	Radiated Emissions	Complies	10.53 dB at 30.000 MHz
3.5	15.225(e)	Frequency Stability	Complies	-
3.6	15.203	Antenna Requirements	Complies	-

Test Items	Uncertainty	Remark
AC Power Line Conducted Emissions	±2.26dB	Confidence levels of 95%
Radiated Emissions (30MHz~1000MHz)	±4.70dB	Confidence levels of 95%



2. GENERAL INFORMATION

2.1 Applicant

Motorola Mobility, LLC

222 W Merchandise Mart Plaza, Suite 1800, Chicago, IL 60654, United States

2.2 Manufacturer

Motorola Mobility, LLC

222 W Merchandise Mart Plaza, Suite 1800, Chicago, IL 60654, United States

2.3 Feature of Equipment Under Test

Product Feature	
Equipment	Mobile Cellular Phone
Brand Name	Motorola Mobility, LLC
FCC Model Name	3578
FCC ID	IHDT56QA1
IMEI Code	359279050020145 359279050020046
EUT supports Radios application	GSM/EGPRS/WCDMA/HSPA/LTE/NFC WLAN 11b/g/n HT20 WLAN 11a/n HT20/HT40 WLAN 11ac VHT20/VHT40/VHT80 Bluetooth v3.0 + EDR Bluetooth v4.0 - LE
HW Version	P2
SW Version	KXE21.99.169
EUT Stage	Identical Prototype

Accessory List	
AC Adapter	Brand Name : Motorola
	Model Name : SPN5788A
Earphone	Brand Name : Motorola
	Model Name : SJYN1305A

2.4 Product Specification of Equipment Under Test

Items	Description
Tx/Rx Frequency Range	13.553 ~ 13.567MHz
Channel Number	1
20dBW	2.64kHz
99%OBW	2.24kHz
Antenna Type	Loop Antenna
Type of Modulation	ASK

Remark: The above EUT's information was declared by manufacturer. Please refer to the specifications or user's manual for more detailed description.

2.5 Modification of EUT

No modifications are made to the EUT during all test items.

2.6 Testing Location

Sporton Lab is accredited to ISO 17025 by Taiwan Accreditation Foundation (TAF code : 1190) and the FCC designation No. TW1022 under the FCC 2.948(e) by Mutual Recognition Agreement (MRA) in FCC Test.

Test Site	SPORTON INTERNATIONAL INC.		
Test Site Location	No. 52, Hwa Ya 1 st Rd., Hwa Ya Technology Park, Kwei-Shan Hsiang, Tao Yuan Hsien, Taiwan, R.O.C. TEL: +886-3-3273456 / FAX: +886-3-3284978		
Test Site No.	Sporton Site No.		
	TH02-HY	CO05-HY	03CH07-HY
Test Engineer	Tommy Lee	Cosmo Xu	Kai Wang
Temperature	22~24°C	20~22°C	22~23°C
Relative Humidity	53~55%	45~47%	44~46%



2.7 Applicable Standards

According to the specifications of the manufacturer, the EUT must comply with the requirements of the following standards:

- ♦ FCC Part 15 Subpart C §15.225
- ♦ ANSI C63.4-2003

2.8 Test Modes

Investigation has been done on all the possible configurations for searching the worst cases. The following table is a list of the test modes shown in this test report.

Test Items	
AC Power Line Conducted Emissions	Field Strength of Fundamental Emissions
20dB Spectrum Bandwidth	Frequency Stability
Radiated Emissions 9kHz~30MHz	Radiated Emissions 30MHz~1GHz

Note:

1. The EUT was programmed to be in continuously transmitting mode.
2. The ancillary equipment, NFC card, is used to make the EUT (NFC) continuously transmit at 13.56MHz and is placed around 3 cm gap to the EUT.

2.9 Test Configurations

<AC Conducted Emissions>

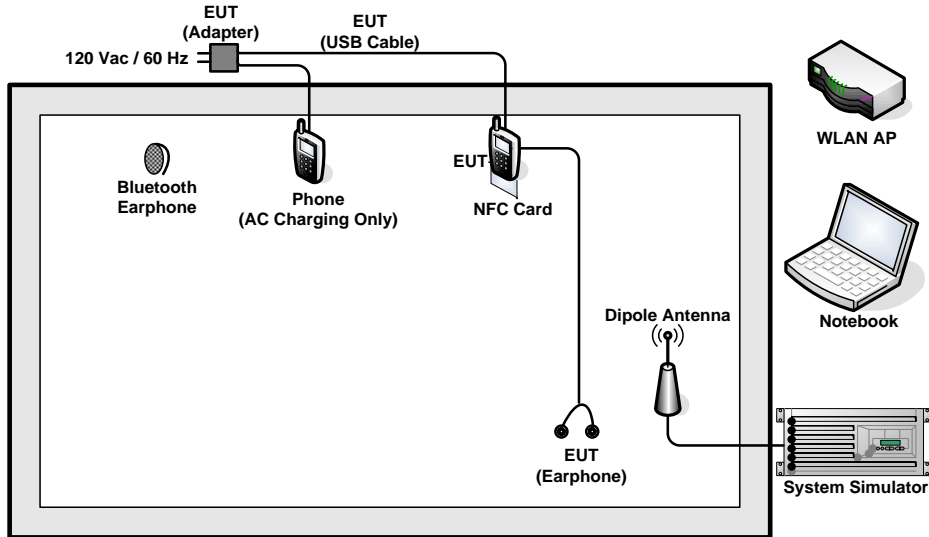

< For Fundamental Emissions and Mask and Radiated Emissions Measurement >

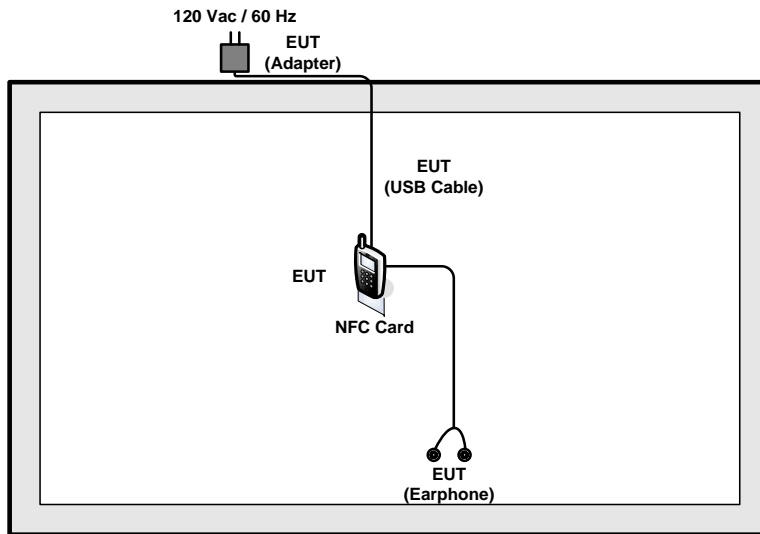



2.10 Table for Supporting Units

Support Unit	Manufacturer	Model	FCC ID	Data Cable	Power Cord
System Simulator	R&S	CMU 200	N/A	N/A	Unshielded, 1.8 m
WLAN AP	D-Link	DIR-628	KA2DIR628A2	N/A	Unshielded, 1.8 m
Bluetooth Earphone	Sony Ericsson	MW600	PY70DA2029	N/A	N/A
NFC Card	Metro Taipei	Easy Card	N/A	N/A	N/A
Notebook	DELL	Latitude E6320	FCC DoC/ Contains FCC ID: QDS-BRCM1054	N/A	AC I/P: Unshielded, 1.2 m DC O/P: Shielded, 1.8 m

3. CONDUCTED EMISSION TEST

3.1 Measuring Instruments

See list of measuring instruments of this test report.

3.2 Test setup

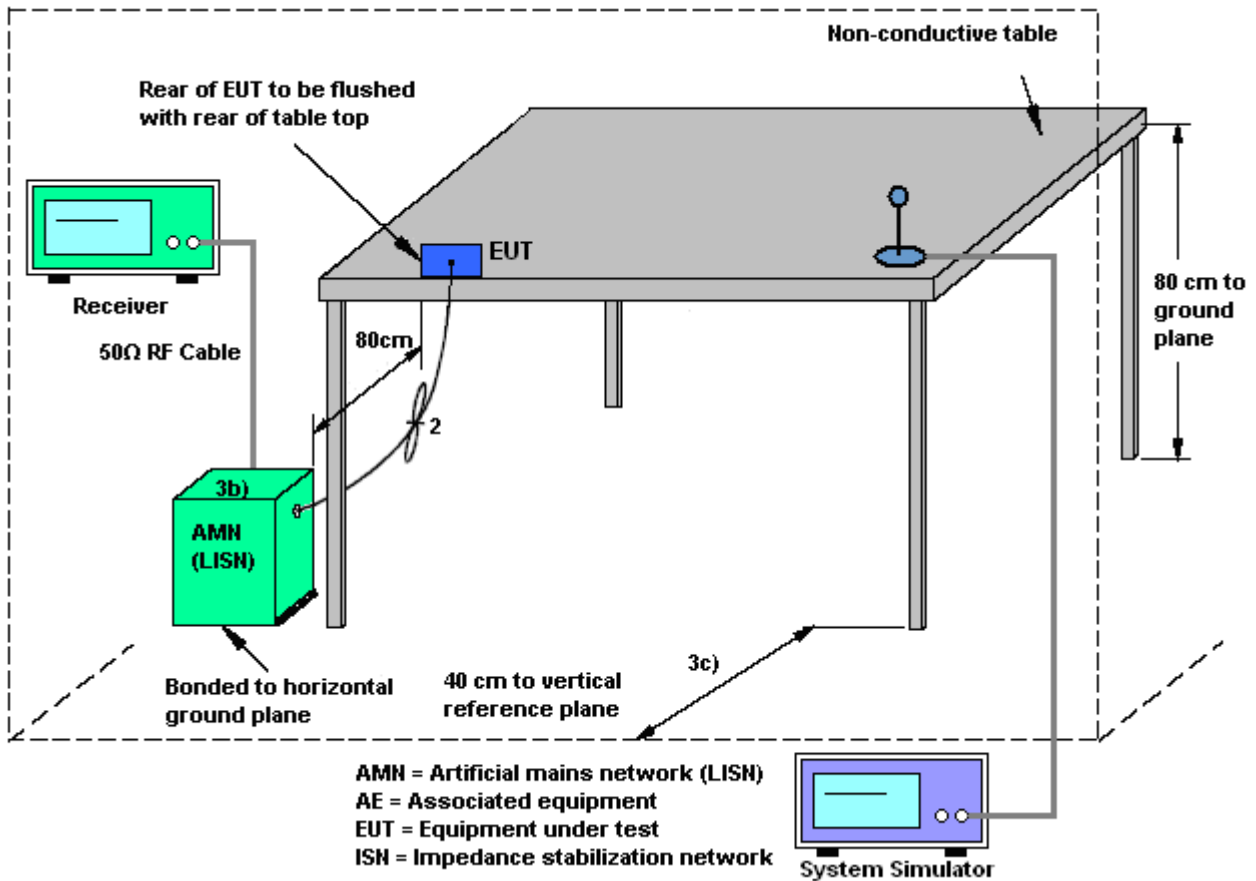

3.3 Test Result of Conducted Emission Test

Please refer to Appendix A.

3.4 AC Power Line Conducted Emissions Measurement

3.4.1 Limit

For equipment that is designed to be connected to the public utility (AC) power line, the radio frequency voltage that is conducted back onto the AC power line on any frequency or frequencies within the band 150 kHz to 30 MHz shall not exceed the limits in the following table.

Frequency of Emission (MHz)	Conducted Limit (dB μ V)	
	Quasi-Peak	Average
0.15-0.5	66 to 56*	56 to 46*
0.5-5	56	46
5-30	60	50

*Decreases with the logarithm of the frequency.

3.4.2 Test Procedures

1. The EUT was placed 0.4 meter from the conducting wall of the shielding room, and it was kept at least 80 centimeters from any other grounded conducting surface.
2. Connect EUT to the power mains through a line impedance stabilization network (LISN).
3. All the support units are connecting to the other LISN.
4. The LISN provides 50 ohm coupling impedance for the measuring instrument.
5. The FCC states that a 50 ohm, 50 microhenry LISN should be used.
6. Both sides of AC line were checked for maximum conducted interference.
7. The frequency range from 150 kHz to 30 MHz was searched.
8. Set the test-receiver system to Peak Detect Function and specified bandwidth with Maximum Hold Mode.
9. Compliance with the limit is tested using a receiver with RBW set to a 9kHz

4. CONDUCTED TEST ITEMS

4.1 Measuring Instruments

See list of measuring instruments of this test report.

4.2 Test Setup

4.2.1 20dB Spectrum Bandwidth

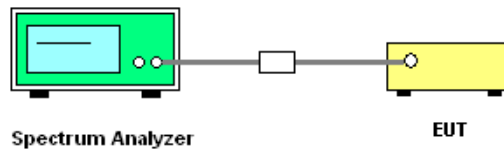

4.2.2 Frequency Stability

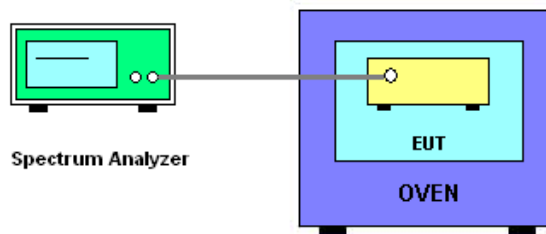

4.3 Test Result of Conducted Test Items

Please refer to Appendix B.



4.4 20dB Spectrum Bandwidth Measurement

4.4.1 Limit

Intentional radiators must be designed to ensure that the 20 dB bandwidth of the emissions in the specific band 13.553~13.567MHz

4.4.2 Test Procedures

1. The transmitter output (antenna port) was connected to the spectrum analyzer in peak Max hold mode.
2. The resolution bandwidth of 1 kHz and the video bandwidth of 3 kHz were used.
3. Measured the spectrum width with power higher than 20dB below carrier.

4.5 Frequency Stability Measurement

4.5.1 Limit

The frequency tolerance of the carrier signal shall be maintained within +/- 0.01% (100ppm) of the operating frequency over a temperature variation of -20 degrees to +50 degrees C at normal supply voltage, and for a variation in the primary supply voltage from 85% to 115% of the rated supply voltage at a temperature of 20 degrees C. For battery operated equipment, the equipment tests shall be performed using a new battery.

4.5.2 Test Procedures

1. The transmitter output (antenna port) was connected to the spectrum analyzer.
2. EUT have transmitted signal and fixed channelize.
3. Set the spectrum analyzer span to view the entire emissions bandwidth.
4. Set RBW = 1 kHz, VBW = 3 kHz with peak detector and maxhold settings.
5. The f_c is declaring of channel frequency. Then the frequency error formula is $(f_c - f) / f_c \times 10^6$ ppm and the limit is less than ± 100 ppm.
6. Extreme temperature rule is -20°C~50°C.

5. RADIATED TEST ITEMS

5.1 Measuring Instruments

See list of measuring instruments of this test report.

5.2 Test Setup

5.2.1 For radiated emissions below 30MHz

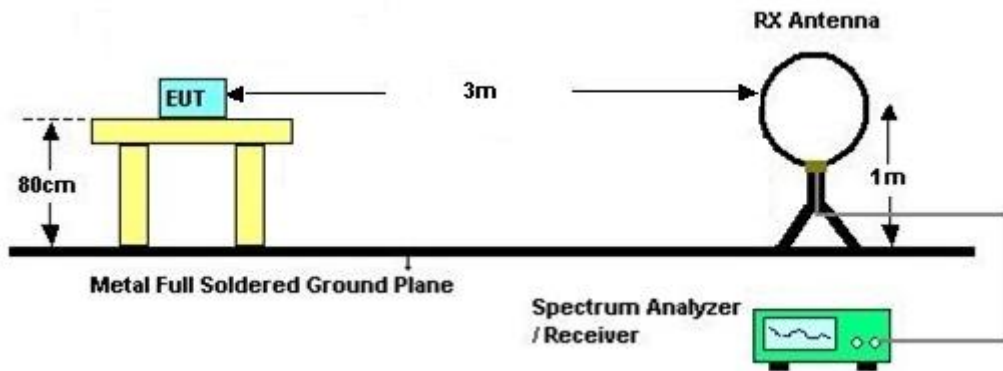

5.2.2 For radiated emissions above 30MHz

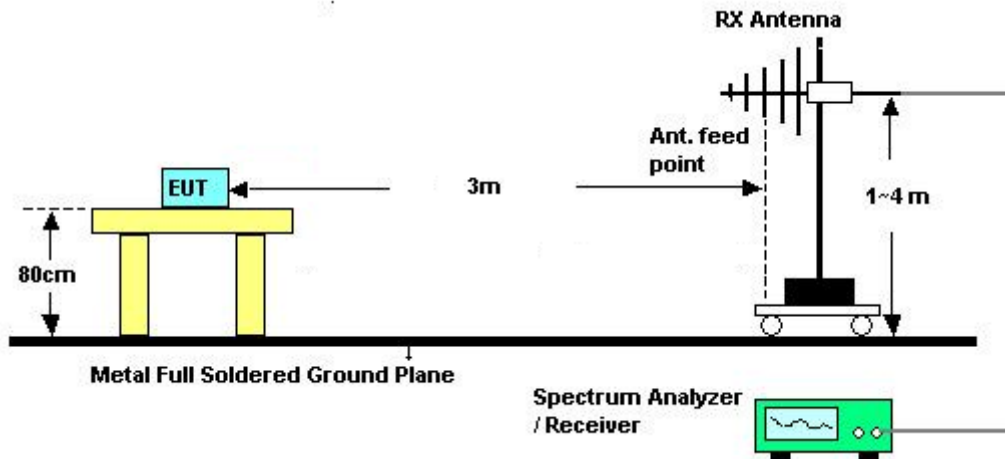

5.3 Test Result of Radiated Test Items

Please refer to Appendix C.

5.4 Field Strength of Fundamental Emissions and Mask Measurement

5.4.1 Limit

Rules and specifications	CFR 47 Part 15 section 15.225(a)-(d)			
Description	Compliance with the spectrum mask is tested using a spectrum analyzer with RBW set to a 9kHz for the band 13.553~13.567MHz			
Freq. of Emission (MHz)	Field Strength (μV/m) at 30m	Field Strength (dBμV/m) at 30m	Field Strength (dBμV/m) at 10m	Field Strength (dBμV/m) at 3m
1.705~13.110	30	29.5	48.58	69.5
13.110~13.410	106	40.5	59.58	80.5
13.410~13.553	334	50.5	69.58	90.5
13.553~13.567	15848	84.0	103.08	124.0
13.567~13.710	334	50.5	69.58	90.5
13.710~14.010	106	40.5	59.58	80.5
14.010~30.000	30	29.5	48.58	69.5

5.4.2 Test Procedures

1. Configure the EUT according to ANSI C63.4. The EUT was placed on the top of the turntable 0.8 meter above ground. The phase center of the loop receiving antenna mounted antenna tower was placed 3 meters far away from the turntable.
2. Power on the EUT and all the supporting units. The turntable was rotated by 360 degrees to determine the position of the highest radiation.
3. The height of the receiving antenna was fixed at one meter above ground to find the maximum emissions field strength.
4. For Fundamental emissions, use the receiver to measure QP reading.
5. When the radiated emissions limits are expressed in terms of the average value of the emissions, and pulsed operation is employed, the measurement field strength shall be determined by averaging over one complete pulse train, including blanking intervals, as long as the pulse train does not exceed 0.1 seconds. As an alternative (provided the transmitter operates for longer than 0.1 seconds) or in cases where the pulse train exceeds 0.1 seconds, the measured field strength shall be determined from the average absolute voltage during a 0.1 second interval during which the field strength is at its maximum value.
6. Compliance with the spectrum mask is tested using a spectrum analyzer with RBW set to a 9kHz for the band 13.553~13.567MHz.

Note: Emission level (dBμV/m) = 20 log Emission level (μV/m).

5.5 Radiated Emissions Measurement

5.5.1 Limit

The field strength of any emissions which appear outside of 13.553~13.567MHz band shall not exceed the general radiated emissions limits.

Frequencies (MHz)	Field Strength (μV/m)	Measurement Distance (meters)
0.009~0.490	2400/F(kHz)	300
0.490~1.705	24000/F(kHz)	30
1.705~30.0	30	30
30~88	100	3
88~216	150	3
216~960	200	3
Above 960	500	3

5.5.2 Measuring Instrument Setting

The following table is the setting of receiver.

Receiver Parameter	Setting
Attenuation	Auto
Frequency Range: 9kHz~150kHz	RBW 200Hz for QP
Frequency Range: 150kHz~30MHz	RBW 9kHz for QP
Frequency Range: 30MHz~1000MHz	RBW 120kHz for Peak

Note: The emission limits shown in the above table are based on measurements employing a CISPR quasi-peak detector except for the frequency bands 9-90 kHz, 110-490 kHz. Radiated emission limits in these two bands are based on measurements employing an average detector.

5.5.3 Test Procedures

1. Configure the EUT according to ANSI C63.4. The EUT was placed on the top of the turntable 0.8 meter above ground. The phase center of the receiving antenna mounted on the top of a height-variable antenna tower was placed 3 meters far away from the turntable.
2. Power on the EUT and all the supporting units. The turntable was rotated by 360 degrees to determine the position of the highest radiation.
3. The height of the broadband receiving antenna was varied between one meter and four meters above ground to find the maximum emissions field strength of both horizontal and vertical polarization.
4. For each suspected emissions, the antenna tower was scan (from 1 M to 4 M) and then the turntable was rotated (from 0 degree to 360 degrees) to find the maximum reading.
5. Set the test-receiver system to Peak or CISPR quasi-peak Detect Function with specified bandwidth under Maximum Hold Mode.
6. When the radiated emissions limits are expressed in terms of the average value of the emissions, and pulsed operation is employed, the measurement field strength shall be determined by averaging over one complete pulse train, including blanking intervals, as long as the pulse train does not exceed 0.1 seconds. As an alternative (provided the transmitter operates for longer than 0.1 seconds) or in cases where the pulse train exceeds 0.1 seconds, the measured field strength shall be determined from the average absolute voltage during a 0.1 second interval during which the field strength is at its maximum value.
7. In case the emission is lower than 30MHz, loop antenna has to be used for measurement and the recorded data should be QP measured by receiver. Antenna Requirements

5.5.4 Limit

Except for special regulations, the Low-power Radio-frequency Devices must not be equipped with any jacket for installing an antenna with extension cable. An intentional radiator shall be designed to ensure that no antenna other than that furnished by the responsible party shall be used with the device. The use of a permanently attached antenna or of an antenna that uses a unique coupling to the intentional radiator shall be considered sufficient to comply with the provisions of this Section. The manufacturer may design the unit so that the user can replace a broken antenna, but the use of a standard antenna jack or electrical connector is prohibited.

5.5.5 Antenna Anti-Replacement Construction

An embedded-in antenna design is used.



6. LIST OF MEASURING EQUIPMENT

Instrument	Manufacturer	Model No.	Serial No.	Characteristics	Calibration Date	Test Date	Due Date	Remark
Spectrum Analyzer	Rohde & Schwarz	FSP40	100055	9kHz~40GHz	Jun. 07, 2013	May 11, 2014	Jun. 06, 2014	Conducted (TH02-HY)
Spectrum Analyzer	Rohde & Schwarz	FSP40	100055	9kHz~40GHz	Jun. 09, 2014	Jun. 17, 2014	Jun. 08, 2015	Conducted (TH02-HY)
Thermal Chamber	Ten Billion	TTH-D3SP	TBN-930701	N/A	Jul. 19, 2013	May 11, 2014~ Jun. 17, 2014	Jul. 18, 2014	Conducted (TH02-HY)
EMI Test Receiver	Rohde & Schwarz	ESCS 30	100356	9kHz ~ 2.75GHz	Nov. 15, 2013	May 14, 2014	Nov. 14, 2014	Conduction (CO05-HY)
LISN (for auxiliary equipment)	Rohde & Schwarz	ENV216	100081	9kHz ~ 30MHz	Dec. 12, 2013	May 14, 2014	Dec. 11, 2014	Conduction (CO05-HY)
LISN	Rohde & Schwarz	ENV216	100080	9kHz ~ 30MHz	Dec. 04, 2013	May 14, 2014	Dec. 03, 2014	Conduction (CO05-HY)
AC Power Source	ChainTek	APC-1000W	N/A	N/A	N/A	May 14, 2014	N/A	Conduction (CO05-HY)
EMI Test Receiver	Rohde & Schwarz	ESCI 7	100724	9kHz~7GHz	Sep. 06, 2013	May 08, 2014	Sep. 05, 2014	Radiation (03CH07-HY)
Loop Antenna	Rohde & Schwarz	HFH2-Z2	860004/0001	9 kHz~30 MHz	Jul. 03, 2012	May 08, 2014	Jul. 02, 2014	Radiation (03CH07-HY)
Bilog Antenna	Schaffner	CBL6111C	2726	30MHz ~ 1GHz	Oct. 10, 2013	May 08, 2014	Oct. 09, 2014	Radiation (03CH07-HY)
Preamplifier	COM-POWER	PA-103A	161241	10 MHz ~ 1GHz	Mar. 17, 2014	May 08, 2014	Mar. 16, 2015	Radiation (03CH07-HY)
Turn Table	ChainTek	ChainTek 3000	N/A	0 ~ 360 degree	N/A	May 08, 2014	N/A	Radiation (03CH07-HY)
Antenna Mast	ChainTek	ChainTek 3000	N/A	N/A	N/A	May 08, 2014	N/A	Radiation (03CH07-HY)

Appendix A. Test Results of Conducted Emission Test

Test Mode :	NFC Tx	Test Voltage :	120Vac / 60Hz
Function Type :	GSM850 Idle + Bluetooth Link + WLAN Link + USB Cable (Charging from Adapter) + NFC Tx + Battery		

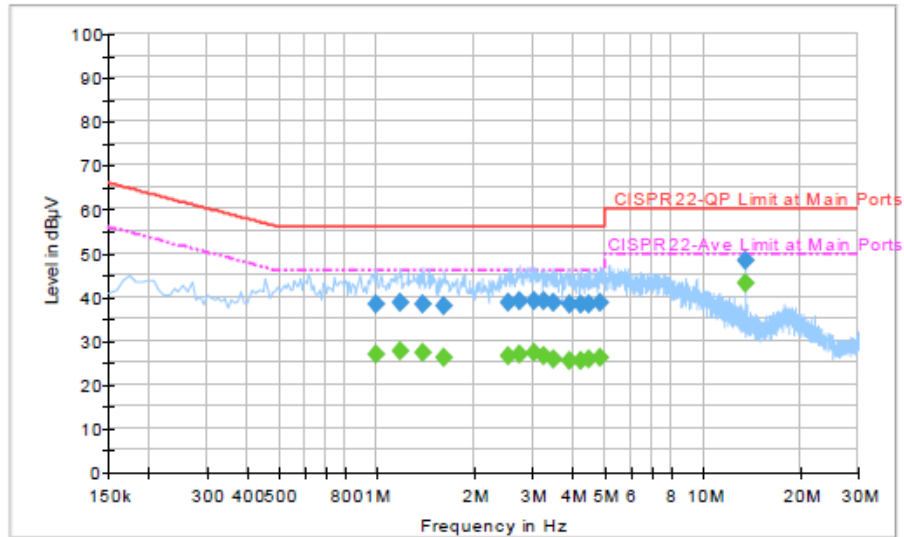

Final Result : Quasi-Peak

Frequency (MHz)	Quasi-Peak (dBµV)	Filter	Line	Corr. (dB)	Margin (dB)	Limit (dBµV)
0.998000	38.5	Off	L1	19.5	17.5	56.0
1.174000	38.8	Off	L1	19.5	17.2	56.0
1.390000	38.5	Off	L1	19.5	17.5	56.0
1.606000	37.9	Off	L1	19.5	18.1	56.0
2.542000	38.7	Off	L1	19.6	17.3	56.0
2.726000	39.0	Off	L1	19.5	17.0	56.0
3.054000	39.2	Off	L1	19.6	16.8	56.0
3.270000	39.1	Off	L1	19.6	16.9	56.0
3.494000	38.6	Off	L1	19.6	17.4	56.0
3.902000	38.2	Off	L1	19.6	17.8	56.0
4.230000	38.2	Off	L1	19.6	17.8	56.0
4.470000	38.6	Off	L1	19.6	17.4	56.0
4.830000	38.6	Off	L1	19.6	17.4	56.0
13.558000	48.3	Off	L1	19.8	11.7	60.0



Test Mode :	NFC Tx	Test Voltage :	120Vac / 60Hz
Function Type :	GSM850 Idle + Bluetooth Link + WLAN Link + USB Cable (Charging from Adapter) + NFC Tx + Battery		

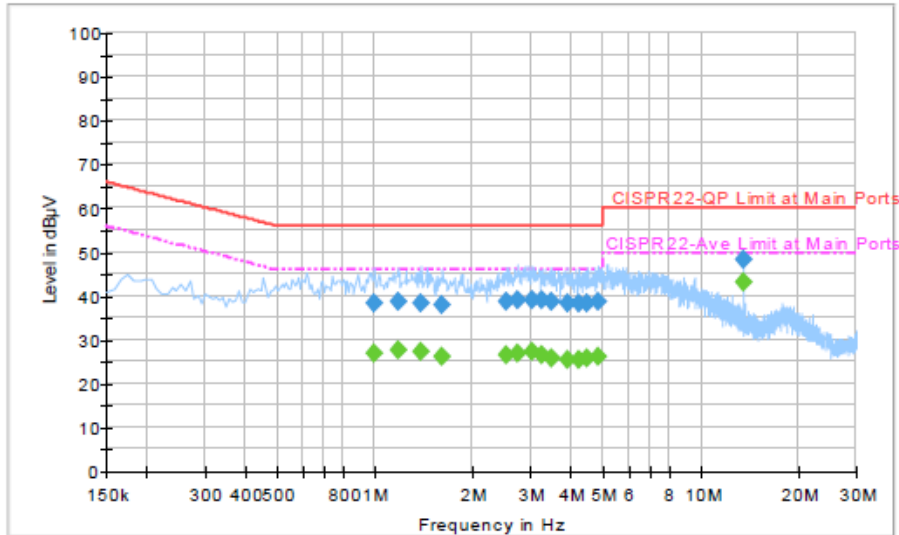

Final Result : Average

Frequency (MHz)	Average (dBµV)	Filter	Line	Corr. (dB)	Margin (dB)	Limit (dBµV)
0.998000	27.1	Off	L1	19.5	18.9	46.0
1.174000	27.8	Off	L1	19.5	18.2	46.0
1.390000	27.4	Off	L1	19.5	18.6	46.0
1.606000	26.2	Off	L1	19.5	19.8	46.0
2.542000	26.5	Off	L1	19.6	19.5	46.0
2.726000	27.0	Off	L1	19.5	19.0	46.0
3.054000	27.2	Off	L1	19.6	18.8	46.0
3.270000	26.7	Off	L1	19.6	19.3	46.0
3.494000	25.8	Off	L1	19.6	20.2	46.0
3.902000	25.5	Off	L1	19.6	20.5	46.0
4.230000	25.4	Off	L1	19.6	20.6	46.0
4.470000	25.8	Off	L1	19.6	20.2	46.0
4.830000	26.3	Off	L1	19.6	19.7	46.0
13.558000	43.2	Off	L1	19.8	6.8	50.0

Test Mode :	NFC Tx	Test Voltage :	120Vac / 60Hz
Function Type :	GSM850 Idle + Bluetooth Link + WLAN Link + USB Cable (Charging from Adapter) + NFC Tx + Battery		

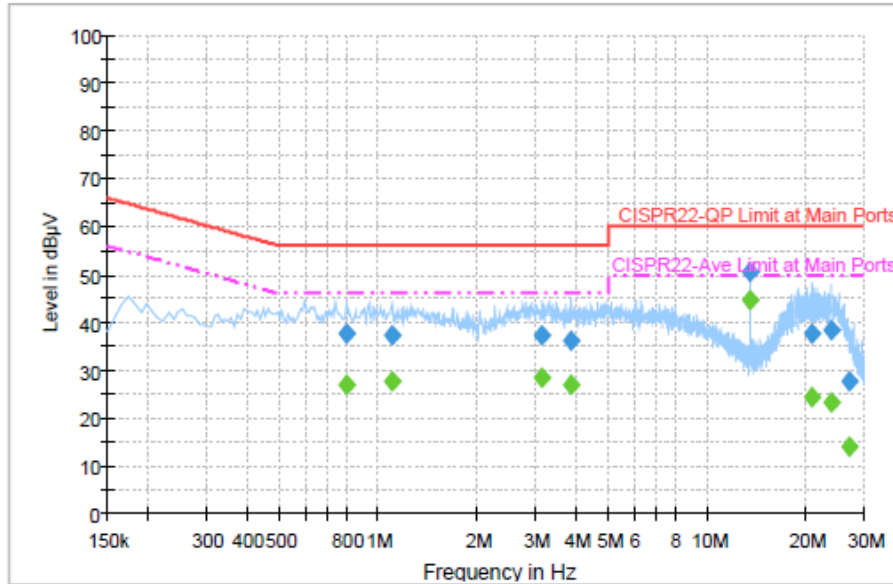

Final Result : Quasi-Peak

Frequency (MHz)	Quasi-Peak (dBµV)	Filter	Line	Corr. (dB)	Margin (dB)	Limit (dBµV)
0.798000	37.5	Off	N	19.4	18.5	56.0
1.102000	37.4	Off	N	19.5	18.6	56.0
3.142000	37.3	Off	N	19.6	18.7	56.0
3.838000	36.2	Off	N	19.6	19.8	56.0
13.558000	50.5	Off	N	19.9	9.5	60.0
20.950000	37.5	Off	N	20.0	22.5	60.0
23.950000	38.2	Off	N	20.0	21.8	60.0
27.118000	27.6	Off	N	20.1	32.4	60.0

Final Result : Average

Frequency (MHz)	Average (dBµV)	Filter	Line	Corr. (dB)	Margin (dB)	Limit (dBµV)
0.798000	26.9	Off	N	19.4	19.1	46.0
1.102000	27.6	Off	N	19.5	18.4	46.0
3.142000	28.4	Off	N	19.6	17.6	46.0
3.838000	26.9	Off	N	19.6	19.1	46.0
13.558000	44.6	Off	N	19.9	5.4	50.0
20.950000	24.2	Off	N	20.0	25.8	50.0
23.950000	23.1	Off	N	20.0	26.9	50.0
27.118000	14.2	Off	N	20.1	35.8	50.0

Remark: 13.558MHz is the NFC RF fundamental signal.



Appendix B. Test Results of Conducted Test Items

B.1 Test Result of 20dB Spectrum Bandwidth

Test mode	NFC Tx	Test Frequency (MHz)	13.56
<p>Ref 20 dBm Att 50 dB SWT 20 ms RBW 1 kHz VBW 3 kHz Marker 1 [T1] 13.55988000 MHz -0.48 dBm BW 2.64000000 kHz Temp 1 [T1] 0.43 dBm 13.55852000 MHz -14.16 dBm Temp 2 [T2] 0.43 dBm 13.56116000 MHz -20.42 dBm</p> <p>Date: 11.MAY.2014 15:31:02</p>		<p>Ref 20 dBm Att 40 dB SWT 20 ms RBW 1 kHz VBW 3 kHz Marker 1 [T1] 13.55988000 MHz 0.43 dBm BW 2.24000000 kHz Temp 1 [T1] 0.43 dBm 13.55852000 MHz -14.16 dBm Temp 2 [T2] 0.43 dBm 13.56096000 MHz -20.42 dBm</p> <p>Date: 11.MAY.2014 15:43:42</p>	
20dB Bandwidth (kHz)	2.640	99% OccupiedBW(kHz)	2.240
Frequency range (MHz)	$f_L > 13.553$	13.55852	Test Result
	$f_H < 13.567$	13.56116	Complies



B.2 Test Result of Frequency Stability

Voltage vs. Frequency Stability		Temperature vs. Frequency Stability	
Voltage (Vdc)	Measurement Frequency (MHz)	Temperature (°C)	Measurement Frequency (MHz)
4.35	13.559820	-20	13.559880
3.9	13.559820	-10	13.559880
3.4	13.559820	0	13.559890
-	-	10	13.559860
-	-	20	13.559850
-	-	30	13.559840
-	-	40	13.559820
-	-	50	13.559800
Max.Deviation (MHz)	-0.000180	Max.Deviation (MHz)	-0.000200
Max.Deviation (ppm)	-13.2743	Max.Deviation (ppm)	-14.7493
Limit	FS < ±100 ppm	Limit	FS < ±100 ppm
Test Result	PASS	Test Result	PASS



Appendix C. Test Results of Radiated Test Items

C.1 Test Result of Field Strength of Fundamental Emissions

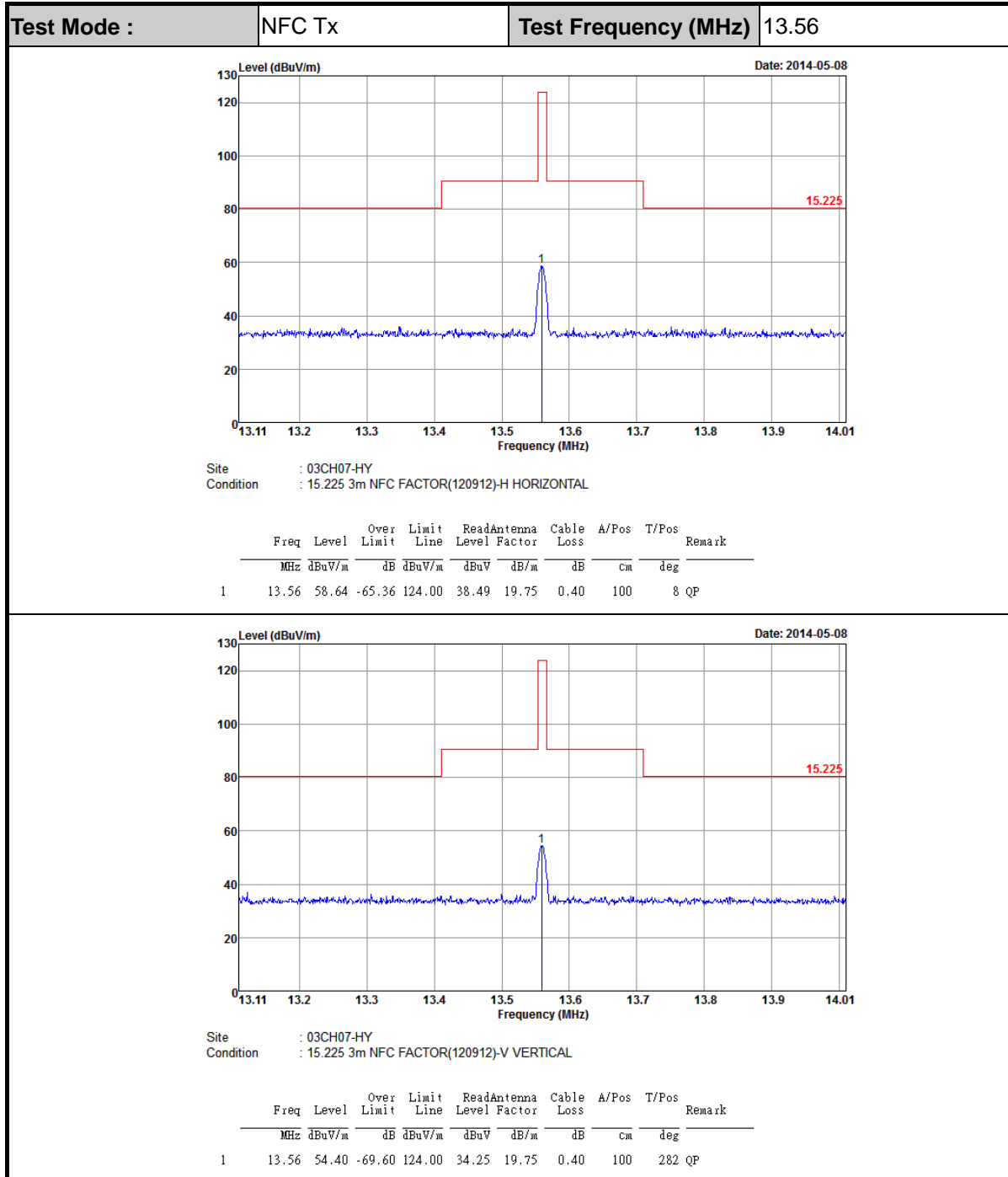

Note: All NFC's spurious emissions are below 20dB of limits.



C.2 Results of Radiated Emissions (9 kHz~30MHz)

Test Mode :		NFC Tx				Polarization :		Horizontal	
Frequency (MHz)	Level (dB μ V/m)	Over Limit (dB)	Limit Line (dB μ V/m)	Read Level (dB μ V)	Antenna Factor (dB)	Cable Loss (dB)	Ant Pos (cm)	Table Pos (deg)	Remark
0.01798	35.22	-87.29	122.51	14.67	20.26	0.29	-	-	Average
0.07173	21.63	-88.86	110.49	1.23	20.11	0.29	-	-	Average
0.09944	22.19	-85.46	107.65	1.83	20.07	0.29	-	-	QP
0.13796	21.07	-83.74	104.81	0.72	20.06	0.29	-	-	Average
0.45226	38.34	-56.16	94.5	18.05	20	0.29	-	-	Average
1.632	39.87	-23.48	63.35	19.52	20.02	0.33	100	16	QP
11.92	35.98	-34.02	70	15.81	19.77	0.4	-	-	QP
13.56	58.36	-	-	38.21	19.75	0.4	-	-	QP
21.013	37.25	-32.75	70	16.59	20.23	0.43	-	-	QP
29.42	36.02	-33.98	70	15.34	20.17	0.51	-	-	QP



Test Mode :		NFC Tx			Polarization :		Vertical		
Frequency (MHz)	Level (dBμV/m)	Over Limit (dB)	Limit Line (dBμV/m)	Read Level (dBμV)	Antenna Factor (dB)	Cable Loss (dB)	Ant Pos (cm)	Table Pos (deg)	Remark
0.01298	36.89	-88.45	125.34	16.34	20.26	0.29	-	-	Average
0.06135	23.06	-88.79	111.85	2.66	20.11	0.29	-	-	Average
0.09668	26.11	-81.79	107.9	5.75	20.07	0.29	-	-	QP
0.13116	26.58	-78.67	105.25	6.23	20.06	0.29	-	-	Average
0.45294	51.2	-43.28	94.48	30.91	20	0.29	-	-	Average
0.52755	51.42	-21.74	73.16	31.11	20	0.31	100	269	QP
8.408	36.04	-33.96	70	15.89	19.77	0.38	-	-	QP
13.56	54.09	-	-	33.94	19.75	0.4	-	-	QP
20.257	38.48	-31.52	70	17.88	20.17	0.43	-	-	QP
26	37.03	-32.97	70	16.16	20.4	0.47	-	-	QP

Note:

1. 13.56 MHz is fundamental signal which can be ignored.
2. The amplitude of spurious emissions which are attenuated by more than 20dB below the permissible value has no need to be reported.
3. Distance extrapolation factor = $40 \log (\text{specific distance} / \text{test distance})$ (dB);
4. Limit line = specific limits (dBμV) + distance extrapolation factor.



C.3 Results of Radiated Emissions (30MHz~1GHz)

Test Mode :		NFC Tx			Polarization :		Horizontal			
Frequency (MHz)	Level (dB μ V/m)	Over Limit (dB)	Limit Line (dB μ V/m)	Read Level (dB μ V)	Antenna Factor (dB)	Cable Loss (dB)	Preamp Factor (dB)	Ant Pos (cm)	Table Pos (deg)	Remark
31.08	23.58	-16.42	40	36.22	18.28	0.54	31.46	-	-	Peak
89.94	24.11	-19.39	43.5	45.57	8.7	0.94	31.1	-	-	Peak
300	30.02	-15.98	46	46.05	13.2	1.77	31	-	-	Peak
301.4	32.39	-13.61	46	48.4	13.22	1.77	31	100	85	Peak
475.7	26.71	-19.29	46	37.59	17.55	2.37	30.8	-	-	Peak
936.3	27.01	-18.99	46	29.65	24.3	3.43	30.37	-	-	Peak

Test Mode :		NFC Tx			Polarization :		Vertical			
Frequency (MHz)	Level (dB μ V/m)	Over Limit (dB)	Limit Line (dB μ V/m)	Read Level (dB μ V)	Antenna Factor (dB)	Cable Loss (dB)	Preamp Factor (dB)	Ant Pos (cm)	Table Pos (deg)	Remark
30	29.47	-10.53	40	41.64	18.8	0.53	31.5	100	169	Peak
43.23	28.98	-11.02	40	48.34	11.2	0.64	31.2	-	-	Peak
91.02	26.07	-17.43	43.5	47.42	8.8	0.95	31.1	-	-	Peak
386.1	25.19	-20.81	46	38.71	15.34	2.11	30.97	-	-	Peak
451.2	25.05	-20.95	46	36.19	17.31	2.3	30.75	-	-	Peak
916	26.4	-19.6	46	29.58	23.77	3.38	30.33	-	-	Peak

Note:

1. The amplitude of spurious emissions which are attenuated by more than 20dB below the permissible value has no need to be reported.
2. Emission level (dB μ V/m) = 20 log Emission level (μ V/m).
3. Corrected Reading: Antenna Factor + Cable Loss + Read Level - Preamp Factor= Level.