

FCC/IC RF Test Report

APPLICANT : Motorola Mobility, LLC
EQUIPMENT : Mobile Cellular Phone
BRAND NAME : Motorola Mobility, LLC
MODEL NAME : 4017
FCC ID : IHDT56PJ3
IC : 109O-T56PJ3
STANDARD : FCC Part 15 Subpart C §15.247
IC RSS-210 issue 8
CLASSIFICATION : (DTS) Digital Transmission System

The product was received on Mar. 11, 2014 and testing was completed on Apr. 03, 2014. We, SPORTON INTERNATIONAL INC., would like to declare that the tested sample has been evaluated in accordance with the procedures and shown to be compliant with the applicable technical standards.

The test results in this report apply exclusively to the tested model / sample. Without written approval of SPORTON INTERNATIONAL INC., the test report shall not be reproduced except in full.



Reviewed by: Joseph Lin / Supervisor



Approved by: Jones Tsai / Manager



SPORTON INTERNATIONAL INC.

No. 52, Hwa Ya 1st Rd., Hwa Ya Technology Park, Kwei-Shan Hsiang, Tao Yuan Hsien, Taiwan, R.O.C.

SPORTON INTERNATIONAL INC.

TEL : 886-3-327-3456

FAX : 886-3-328-4978

FCC ID : IHDT56PJ3

IC: 109O-T56PJ3

Page Number : 1 of 55

Report Issued Date : Apr. 09, 2014

Report Version : Rev. 01



TABLE OF CONTENTS

REVISION HISTORY..... 3

SUMMARY OF TEST RESULT 4

1 GENERAL DESCRIPTION 5

 1.1 Applicant 5

 1.2 Manufacturer 5

 1.3 Feature of Equipment Under Test 5

 1.4 Product Specification of Equipment Under Test 6

 1.5 Modification of EUT 6

 1.6 Testing Location 6

 1.7 Applied Standards 7

2 TEST CONFIGURATION OF EQUIPMENT UNDER TEST 8

 2.1 Carrier Frequency Channel 8

 2.2 Pre-Scanned RF Power 9

 2.3 Test Mode 10

 2.4 Connection Diagram of Test System 11

 2.5 Support Unit used in test configuration and system 12

 2.6 EUT Operation Test Setup 12

 2.7 Measurement Results Explanation Example 12

3 TEST RESULT 13

 3.1 6dB and 99% Bandwidth Measurement 13

 3.2 Output Power Measurement 15

 3.3 Power Spectral Density Measurement 18

 3.4 Conducted Band Edges and Spurious Emission Measurement 20

 3.5 Radiated Band Edges and Spurious Emission Measurement 30

 3.6 AC Conducted Emission Measurement 49

 3.7 Antenna Requirements 53

4 LIST OF MEASURING EQUIPMENT 54

5 UNCERTAINTY OF EVALUATION 55



SUMMARY OF TEST RESULT

Report Section	FCC Rule	IC Rule	Description	Limit	Result	Remark
3.1	15.247(a)(2)	RSS-210 A8.2(a)	6dB Bandwidth	$\geq 0.5\text{MHz}$	Pass	-
3.1	-	RSS-Gen 4.6.1	99% Bandwidth	-	Pass	-
3.2	15.247(b)	RSS-210 A8.4	Power Output Measurement	$\leq 30\text{dBm}$	Pass	-
3.3	15.247(e)	RSS-210 A8.2(b)	Power Spectral Density	$\leq 8\text{dBm}/3\text{kHz}$	Pass	-
3.4	15.247(d)	RSS-210 A8.5	Conducted Band Edges	$\leq 20\text{dBc}$	Pass	-
			Conducted Spurious Emission		Pass	-
3.5	15.247(d)	RSS-210 A8.5	Radiated Band Edges and Radiated Spurious Emission	15.209(a) & 15.247(d)	Pass	Under limit 2.25 dB at 2389.380 MHz
3.6	15.207	RSS-Gen 7.2.4	AC Conducted Emission	15.207(a)	Pass	Under limit 16.10 dB at 1.830 MHz
3.7	15.203 & 15.247(b)	RSS-210 A8.4	Antenna Requirement	N/A	Pass	-



1 General Description

1.1 Applicant

Motorola Mobility, LLC

222 W Merchandise Mart Plaza, Suite 1800, Chicago, IL 60654, United States

1.2 Manufacturer

Motorola Mobility, LLC

222 W Merchandise Mart Plaza, Suite 1800, Chicago, IL 60654, United States

1.3 Feature of Equipment Under Test

Product Feature	
Equipment	Mobile Cellular Phone
Brand Name	Motorola Mobility, LLC
Model Name	4017
FCC ID	IHDT56PJ3
IC	109O-T56PJ3
IMEI Code	355001050021848
EUT supports Radios application	GSM/EGPRS/WCDMA/HSPA WLAN 11b/g/n HT20 Bluetooth v3.0 + EDR Bluetooth v4.0 - LE
HW Version	P2A
SW Version	1034.302.18.00R
EUT Stage	Identical Prototype

Remark: The above EUT's information was declared by manufacturer. Please refer to the specifications or user's manual for more detailed description.



1.4 Product Specification of Equipment Under Test

Product Specification subjective to this standard	
Tx/Rx Channel Frequency Range	802.11b/g/n : 2412 MHz ~ 2462 MHz
Maximum (Peak) Output Power to Antenna	802.11b : 21.48 dBm (0.1406 W) 802.11g : 21.92 dBm (0.1556 W) 802.11n HT20 : 21.81 dBm (0.1517 W)
99% Occupied Bandwidth	802.11b : 13.60MHz 802.11g : 18.30MHz 802.11n HT20 : 19.10MHz
Antenna Type	802.11b/g/n : L-Type Antenna with gain 1.10 dBi
Type of Modulation	802.11b : DSSS (DBPSK / DQPSK / CCK) 802.11g/n : OFDM (BPSK / QPSK / 16QAM / 64QAM)

1.5 Modification of EUT

No modifications are made to the EUT during all test items.

1.6 Testing Location

Sporton Lab is accredited to ISO 17025 by Taiwan Accreditation Foundation (TAF code : 1190) and the FCC designation No. TW1022 under the FCC 2.948(e) by Mutual Recognition Agreement (MRA) in FCC Test.

Test Site	SPORTON INTERNATIONAL INC.			
Test Site Location	No. 52, Hwa Ya 1 st Rd., Hwa Ya Technology Park, Kwei-Shan Hsiang, Tao Yuan Hsien, Taiwan, R.O.C. TEL: +886-3-327-3456 / FAX: +886-3-328-4978			
Test Site No.	Sporton Site No.			IC Registration No.
	TH02-HY	CO05-HY	03CH07-HY	4086B-1



1.7 Applied Standards

According to the specifications of the manufacturer, the EUT must comply with the requirements of the following standards:

- ♦ FCC Part 15 Subpart C §15.247
- ♦ FCC KDB Publication No. 558074 D01 DTS Meas. Guidance v03r01
- ♦ ANSI C63.4-2003
- ♦ IC RSS-210 Issue 8
- ♦ IC RSS-Gen Issue 3
- ♦ NOTICE 2012-DRS0126

Remark:

1. All test items were verified and recorded according to the standards and without any deviation during the test.
2. This EUT has also been tested and complied with the requirements of FCC Part 15, Subpart B, recorded in a separate test report.
3. Per the section 2.2.3 of Notice of 2012-DRS0126, " Receivers Excluded from Industry Canada Requirements", only radiocommunication receivers operating in stand-alone mode within the band 30-960 MHz and scanner receivers are subject to Industry Canada requirements.



2 Test Configuration of Equipment Under Test

The EUT has been associated with peripherals and configuration operated in a manner tended to maximize its emission characteristics in a typical application. Frequency range investigated: conducted emission (150 kHz to 30 MHz) and radiated emission (9 kHz to the 10th harmonic of the highest fundamental frequency or to 40 GHz, whichever is lower). For radiated measurement, pre-scanned in three orthogonal planes, X, Y, Z. The worst cases (Y plane) were recorded in this report.

The final configuration from all the combinations and the worst-case data rates were investigated by measuring the maximum power across all the data rates and modulation modes under section 2.2.

Based on the worst configuration found above, the RF power setting is set individually to meet FCC compliance limit for the final conducted and radiated tests shown in section 2.3.

2.1 Carrier Frequency Channel

Frequency Band	Channel	Freq. (MHz)	Channel	Freq. (MHz)
2400-2483.5 MHz	1	2412	7	2442
	2	2417	8	2447
	3	2422	9	2452
	4	2427	10	2457
	5	2432	11	2462
	6	2437	-	-



2.2 Pre-Scanned RF Power

Preliminary tests were performed in different data rate and data rate associated with the highest power were chosen for full test shown in the following tables.

Channel	Frequency	2.4GHz 802.11b RF Power (dBm)			
		DSSS Data Rate			
		1 Mbps	2 Mbps	5.5 Mbps	11 Mbps
CH 01	2412MHz	21.26	21.17	21.24	21.23
CH 06	2437MHz	21.48	21.42	21.46	21.38
CH 11	2462MHz	21.25	21.18	21.21	21.24

Channel	Frequency	2.4GHz 802.11g RF Power (dBm)							
		OFDM Data Rate							
		6 Mbps	9 Mbps	12 Mbps	18 Mbps	24 Mbps	36 Mbps	48 Mbps	54 Mbps
CH 01	2412MHz	17.83	17.46	17.56	17.61	17.54	17.63	17.68	17.70
CH 06	2437MHz	21.92	21.90	21.82	21.68	21.74	21.86	21.89	21.78
CH 11	2462MHz	19.91	19.84	19.76	19.71	19.69	19.82	19.79	19.89

Channel	Frequency	2.4GHz 802.11n HT20 RF Power (dBm)							
		OFDM Data Rate							
		MCS0	MCS1	MCS2	MCS3	MCS4	MCS5	MCS6	MCS7
CH 01	2412MHz	16.92	16.84	16.81	16.87	16.77	16.85	16.89	16.82
CH 06	2437MHz	21.81	21.80	21.75	21.69	21.65	21.72	21.79	21.77
CH 11	2462MHz	19.24	19.20	19.15	19.17	19.11	19.16	19.07	19.21



2.3 Test Mode

Final results of test modes, data rates and test channels are shown as following table.

Test Cases				
	Test Items	Mode	Data Rate	Test Channel
Conducted TCs	6dB and 99% BW Power Spectral Density	802.11b	1 Mbps	1/6/11
		802.11g	6 Mbps	1/6/11
		802.11n HT20	MCS0	1/6/11
	Output Power	802.11b	1 Mbps	1/6/11
		802.11g	6 Mbps	1/6/11
		802.11n HT20	MCS0	1/6/11
	Conducted Band Edge	802.11b	1 Mbps	1/11
		802.11g	6 Mbps	1/11
		802.11n HT20	MCS0	1/11
	Conducted Spurious Emission	802.11b	1 Mbps	1/6/11
		802.11g	6 Mbps	1/6/11
		802.11n HT20	MCS0	1/6/11
Radiated TCs	Radiated Band Edge	802.11b	1 Mbps	1/11
		802.11g	6 Mbps	1/11
		802.11n HT20	MCS0	1/11
	Radiated Spurious Emission	802.11b	1 Mbps	1/6/11
		802.11g	6 Mbps	1/6/11
		802.11n HT20	MCS0	1/6/11

Test Cases	
AC Conducted Emission	Mode 1 : WCDMA Band II Idle + Bluetooth Link + WLAN Link + Camera + Earphone + Battery + Adapter

2.4 Connection Diagram of Test System

<WLAN Tx Mode>

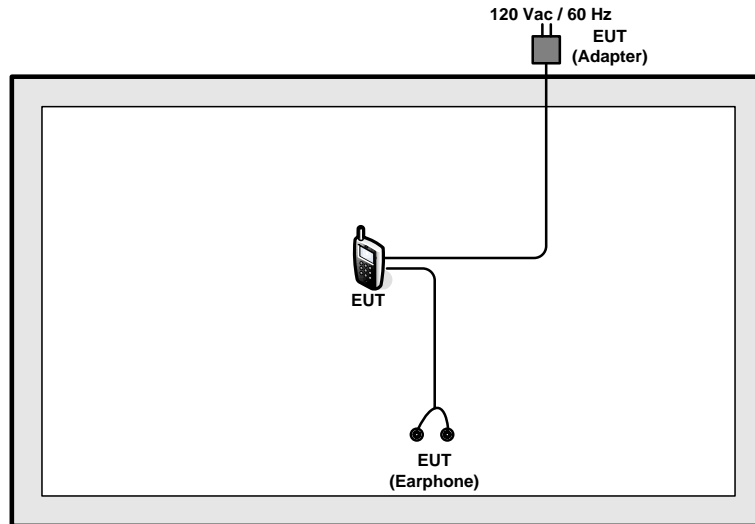

<AC Conducted Emission Mode>

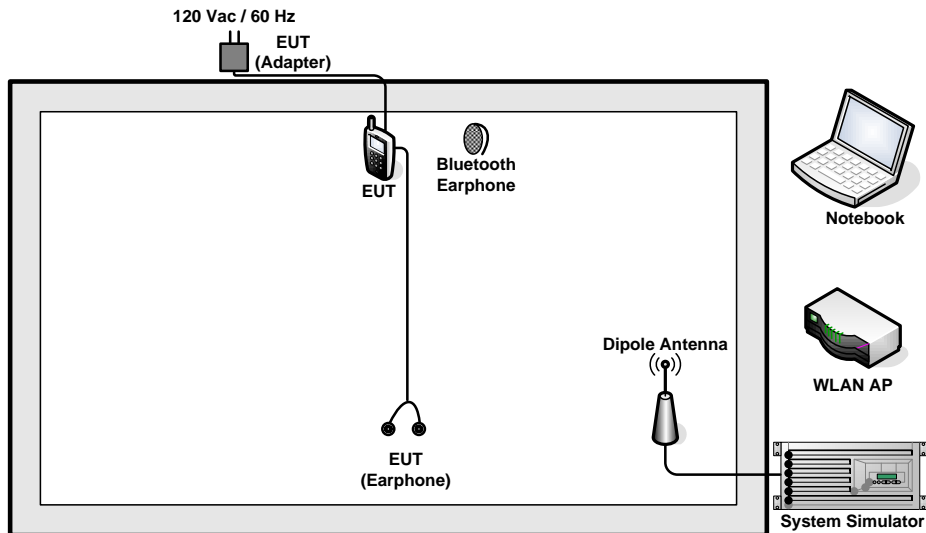

2.5 Support Unit used in test configuration and system

Item	Equipment	Trade Name	Model Name	FCC ID	Data Cable	Power Cord
1.	System Simulator	R&S	CMU 200	N/A	N/A	Unshielded, 1.8 m
2.	WLAN AP	D-Link	DIR-628	KA2DIR628A2	N/A	Unshielded, 1.8 m
3.	Bluetooth Earphone	Sony Ericsson	MW600	PY7DDA-2029	N/A	N/A
4.	Notebook	DELL	Latitude E6320	FCC DoC	N/A	AC I/P: Unshielded, 1.2 m DC O/P: Shielded, 1.8 m
5.	SD Card	SanDisk	MicroSD HC	FCC DoC	N/A	N/A

2.6 EUT Operation Test Setup

For WLAN function, programmed RF utility, “ADB” installed in the notebook make the EUT provide functions like channel selection and power level for continuous transmitting and receiving signals.

2.7 Measurement Results Explanation Example

For all conducted test items:

The offset level is set in the spectrum analyzer to compensate the RF cable loss and attenuator factor between EUT conducted output port and spectrum analyzer. With the offset compensation, the spectrum analyzer reading level is exactly the EUT RF output level.

Example :

The spectrum analyzer offset is derived from RF cable loss and attenuator factor.

Offset = RF cable loss + attenuator factor.

Following shows an offset computation example with cable loss 4.2 dB and 10dB attenuator.

$$\begin{aligned}
 \text{Offset}(dB) &= \text{RF cable loss}(dB) + \text{attenuator factor}(dB). \\
 &= 4.2 + 10 = 14.2 \text{ (dB)}
 \end{aligned}$$

3 Test Result

3.1 6dB and 99% Bandwidth Measurement

3.1.1 Limit of 6dB and 99% Bandwidth

The minimum 6 dB bandwidth shall be at least 500 kHz.

3.1.2 Measuring Instruments

The measuring equipment is listed in the section 4 of this test report.

3.1.3 Test Procedures

1. The testing follows FCC KDB Publication No. 558074 DTS D01 Meas. Guidance v03r01.
2. The RF output of EUT was connected to the spectrum analyzer by RF cable and attenuator. The path loss was compensated to the results for each measurement.
3. Set to the maximum power setting and enable the EUT transmit continuously.
4. Make the measurement with the spectrum analyzer's resolution bandwidth (RBW) = 100 kHz. Set the Video bandwidth (VBW) = 300 kHz. In order to make an accurate measurement. The 6 dB bandwidth must be greater than 500 kHz.
5. For 99% Bandwidth Measurement, the spectrum analyzer's resolution bandwidth (RBW) = 1MHz and set the Video bandwidth (VBW) = 3MHz.
6. Measure and record the results in the test report.

3.1.4 Test Setup

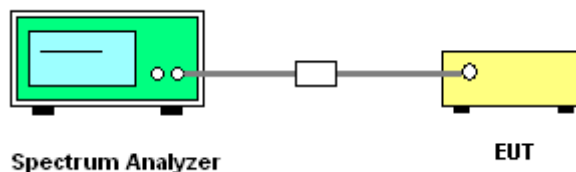



3.1.5 Test Result of 6dB and 99% Occupied Bandwidth

Test Band :	2.4GHz	Temperature :	21~25°C
Test Engineer :	Kenny Chen	Relative Humidity :	51~54%

Mod.	Data Rate	N _{TX}	Channel	Freq. (MHz)	99% Bandwidth (MHz)	6dB Bandwidth (MHz)	6dB Bandwidth Min. Limit (MHz)	Pass/Fail
11b	1Mbps	1	1	2412	13.60	7.56	0.5	Pass
11b	1Mbps	1	6	2437	13.35	7.08	0.5	Pass
11b	1Mbps	1	11	2462	13.10	7.56	0.5	Pass
11g	6Mbps	1	1	2412	18.15	16.36	0.5	Pass
11g	6Mbps	1	6	2437	18.30	16.36	0.5	Pass
11g	6Mbps	1	11	2462	18.25	16.36	0.5	Pass
HT20	MCS0	1	1	2412	19.05	17.56	0.5	Pass
HT20	MCS0	1	6	2437	19.10	17.56	0.5	Pass
HT20	MCS0	1	11	2462	19.00	17.60	0.5	Pass

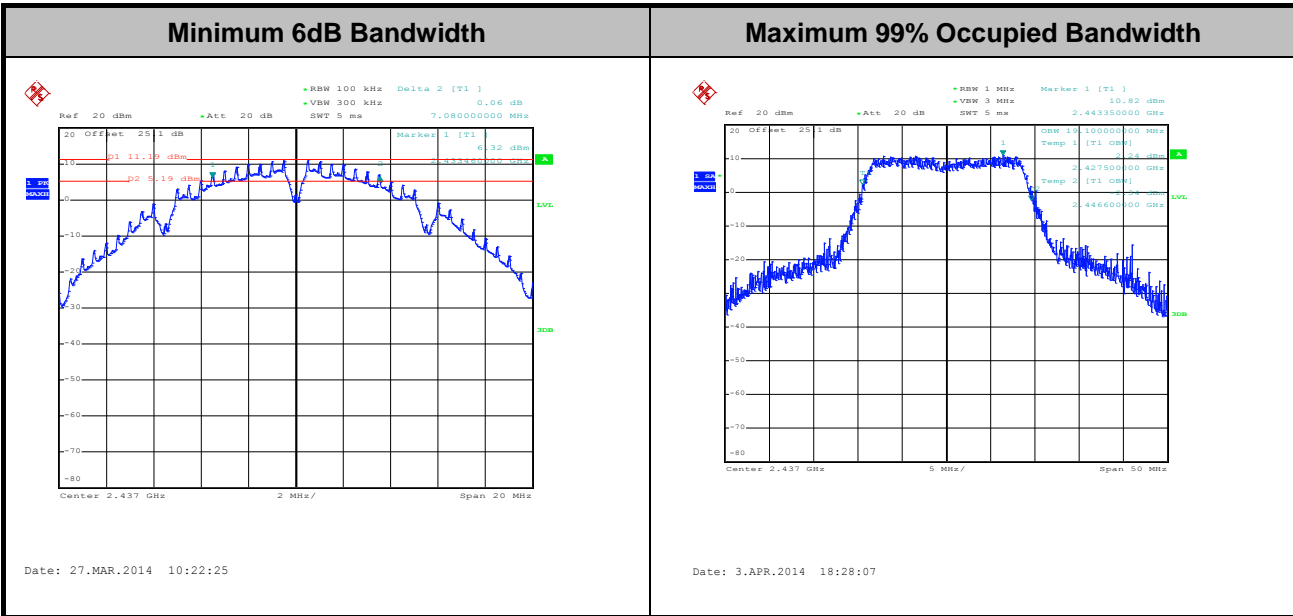

Note : The occupied channel bandwidth is maintained within the band of operation for all of the modulations.

3.2 Output Power Measurement

3.2.1 Limit of Output Power

For systems using digital modulation in the 2400-2483.5MHz, the limit for peak output power is 30dBm. If transmitting Antenna of directional gain greater than 6dBi are used the peak output power from the intentional radiator shall be reduced below the above stated value by the amount in dB that the directional gain of the Antenna exceeds 6 dBi. In case of point-to-point operation, the limit has to be reduced by 1dB for every 3dB that the directional gain of the Antenna exceeds 6dBi.

3.2.2 Measuring Instruments

The measuring equipment is listed in the section 4 of this test report.

3.2.3 Test Procedures

1. The testing follows the Measurement Procedure of FCC KDB No. 558074 DTS D01 Meas. Guidance v03r01.
2. The RF output of EUT was connected to the power meter by RF cable and attenuator. The path loss was compensated to the results for each measurement.
3. Set to the maximum power setting and enable the EUT transmit continuously.
4. Measure the conducted output power and record the results in the test report.

3.2.4 Test Setup

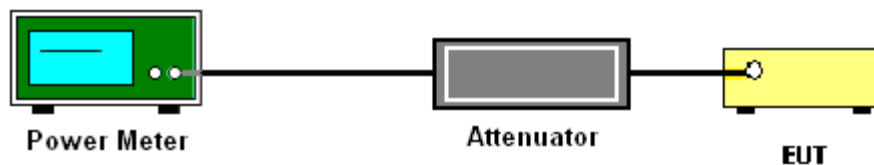



3.2.5 Test Result of Peak Output Power

Test Mode :	2.4GHz	Temperature :	21~25°C
Test Engineer :	Kenny Chen	Relative Humidity :	51~54%

Mod.	Data Rate	N _{TX}	Channel	Freq. (MHz)	RF Output Power (dBm)	Power Limit (dBm)	DG (dBi)	Pass/Fail
11b	1Mbps	1	1	2412	21.26	30	1.10	Pass
11b	1Mbps	1	6	2437	21.48	30	1.10	Pass
11b	1Mbps	1	11	2462	21.25	30	1.10	Pass
11g	6Mbps	1	1	2412	17.83	30	1.10	Pass
11g	6Mbps	1	6	2437	21.92	30	1.10	Pass
11g	6Mbps	1	11	2462	19.91	30	1.10	Pass
HT20	MCS0	1	1	2412	16.92	30	1.10	Pass
HT20	MCS0	1	6	2437	21.81	30	1.10	Pass
HT20	MCS0	1	11	2462	19.24	30	1.10	Pass

Note: Measured power (dBm) has offset with cable loss.



3.2.6 Test Result of Average output Power (Reporting Only)

Test Mode :	2.4GHz	Temperature :	21~25°C
Test Engineer :	Kenny Chen	Relative Humidity :	51~54%

Mod.	Data Rate	N _{TX}	Channel	Freq. (MHz)	Duty Factor (dB)	Average Output Power (dBm)	Power Limit (dBm)	DG (dBi)	Pass/Fail
11b	1Mbps	1	1	2412	0.10	18.78	30	1.10	Pass
11b	1Mbps	1	6	2437	0.10	18.97	30	1.10	Pass
11b	1Mbps	1	11	2462	0.10	18.59	30	1.10	Pass
11g	6Mbps	1	1	2412	0.59	8.33	30	1.10	Pass
11g	6Mbps	1	6	2437	0.59	14.17	30	1.10	Pass
11g	6Mbps	1	11	2462	0.59	9.62	30	1.10	Pass
HT20	MCS0	1	1	2412	0.63	7.54	30	1.10	Pass
HT20	MCS0	1	6	2437	0.63	14.19	30	1.10	Pass
HT20	MCS0	1	11	2462	0.63	9.47	30	1.10	Pass

Note: Measured power (dBm) has offset with cable loss and duty factor.

3.3 Power Spectral Density Measurement

3.3.1 Limit of Power Spectral Density

The peak power spectral density shall not be greater than 8dBm in any 3kHz band at any time interval of continuous transmission.

3.3.2 Measuring Instruments

The measuring equipment is listed in the section 4 of this test report.

3.3.3 Test Procedures

1. The testing follows Measurement Procedure 10.2 Method PKPSD of FCC KDB Publication No. 558074 D01 DTS Meas. Guidance v03r01
2. The RF output of EUT was connected to the spectrum analyzer by RF cable and attenuator. The path loss was compensated to the results for each measurement.
3. Set to the maximum power setting and enable the EUT transmit continuously.
4. Make the measurement with the spectrum analyzer's resolution bandwidth (RBW) = 3 kHz. Video bandwidth VBW = 10 kHz In order to make an accurate measurement, set the span to 1.5 times DTS Channel Bandwidth. (6dB BW)
5. Detector = peak, Sweep time = auto couple, Trace mode = max hold, Allow trace to fully stabilize. Use the peak marker function to determine the maximum power level.
6. Measure and record the results in the test report.

3.3.4 Test Setup

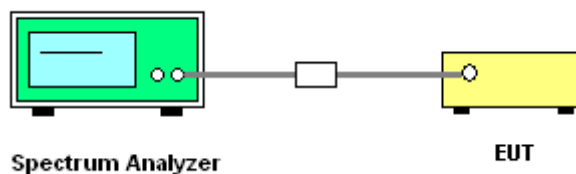



3.3.5 Test Result of Power Spectral Density

Test Mode :	2.4GHz	Temperature :	21~25°C
Test Engineer :	Kenny Chen	Relative Humidity :	51~54%

Mod.	Data Rate	N _{TX}	Channel	Freq. (MHz)	Peak Power Density (dBm/3kHz)	Max. Limits (dBm/3kHz)	DG (dBi)	Pass/Fail
11b	1Mbps	1	1	2412	-3.02	8	1.10	Pass
11b	1Mbps	1	6	2437	-2.62	8	1.10	Pass
11b	1Mbps	1	11	2462	-2.86	8	1.10	Pass
11g	6Mbps	1	1	2412	-16.86	8	1.10	Pass
11g	6Mbps	1	6	2437	-11.56	8	1.10	Pass
11g	6Mbps	1	11	2462	-14.95	8	1.10	Pass
HT20	MCS0	1	1	2412	-18.04	8	1.10	Pass
HT20	MCS0	1	6	2437	-11.53	8	1.10	Pass
HT20	MCS0	1	11	2462	-16.01	8	1.10	Pass

Note: Measured power density (dBm) has offset with cable loss.

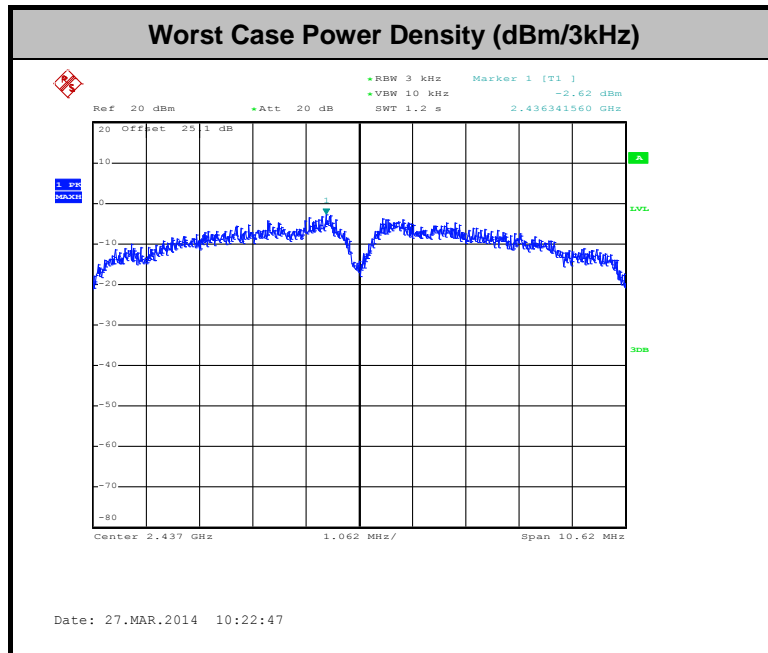

3.4 Conducted Band Edges and Spurious Emission Measurement

3.4.1 Limit of Conducted Band Edges and Spurious Emission Measurement

In any 100 kHz bandwidth outside of the authorized frequency band, the emissions which fall in the non-restricted bands shall be attenuated at least 20 dB / 30dB relative to the maximum PSD level in 100 kHz by RF conducted measurement and radiated emissions which fall in the restricted bands, as defined in Section 15.205(a), must also comply with the radiated emission limits specified in Section 15.209(a).

3.4.2 Measuring Instruments

The measuring equipment is listed in the section 4 of this test report.

3.4.3 Test Procedures

1. The testing follows FCC KDB Publication No. 558074 D01 DTS Meas. Guidance v03r01.
2. The RF output of EUT was connected to the spectrum analyzer by RF cable and attenuator. The path loss was compensated to the results for each measurement.
3. Set to the maximum power setting and enable the EUT transmit continuously.
4. Set RBW = 100 kHz, VBW=300 kHz, Peak Detector. Unwanted Emissions measured in any 100 kHz bandwidth outside of the authorized frequency band shall be attenuated by at least 20 dB relative to the maximum in-band peak PSD level in 100 kHz when maximum peak conducted output power procedure is used. If the transmitter complies with the conducted power limits based on the use of RMS averaging over a time interval, the attenuation required under this paragraph shall be 30 dB instead of 20 dB per 15.247(d).
5. Measure and record the results in the test report.
6. The RF fundamental frequency should be excluded against the limit line in the operating frequency band.

3.4.4 Test Setup

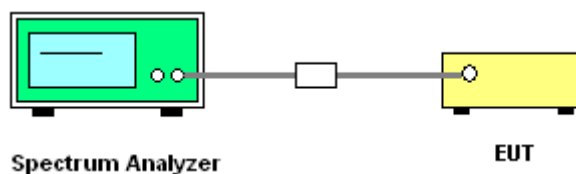



3.4.5 Test Result of Conducted Band Edges and Spurious Emission

Test Mode :	802.11b	Temperature :	21~25°C
Test Band :	2.4GHz Low	Relative Humidity :	51~54%
Test Channel :	01	Test Engineer :	Kenny Chen

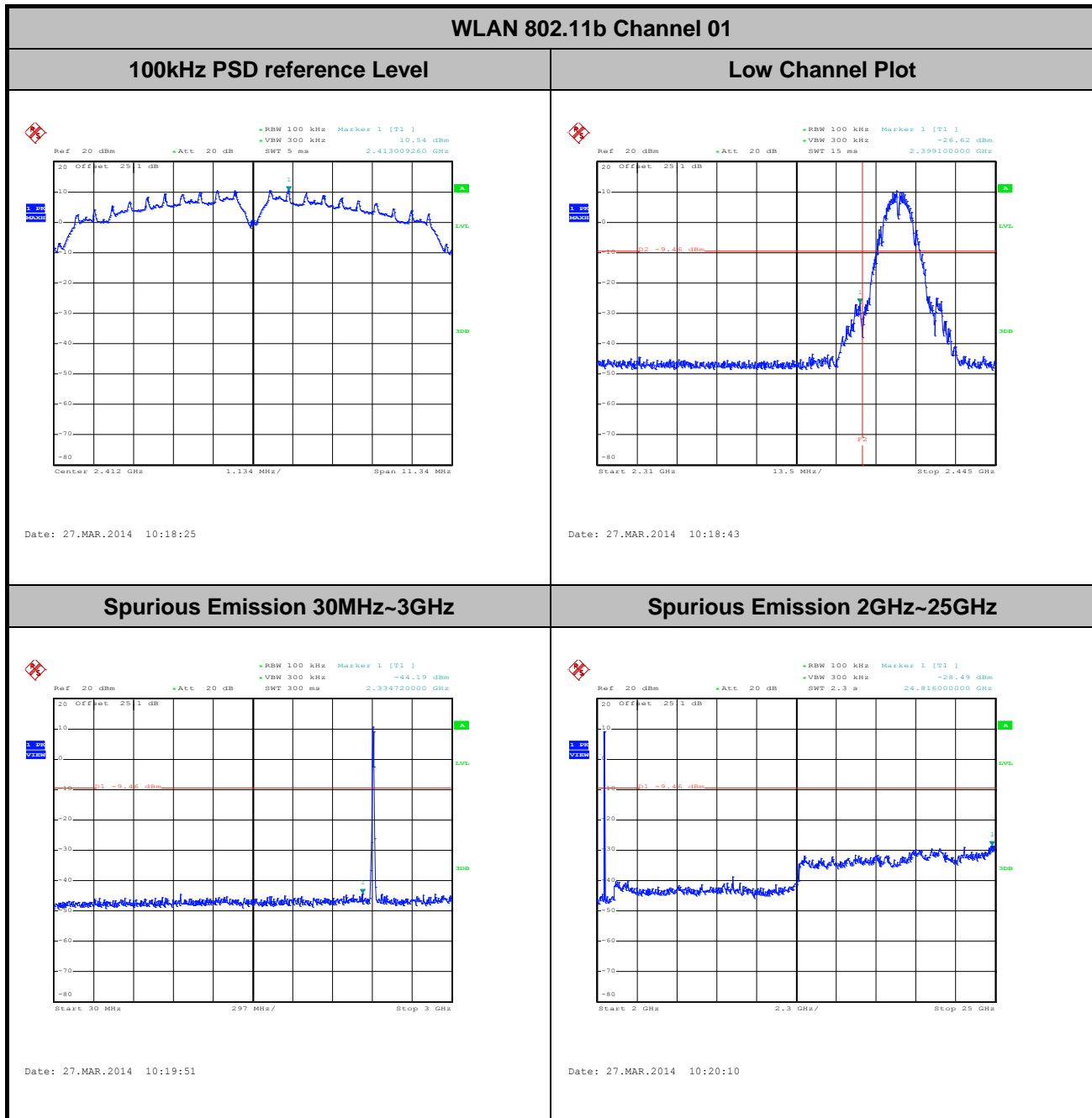



Test Mode :	802.11b	Temperature :	21~25°C
Test Band :	2.4GHz Mid	Relative Humidity :	51~54%
Test Channel :	06	Test Engineer :	Kenny Chen

WLAN 802.11b Channel 06

100kHz PSD reference Level

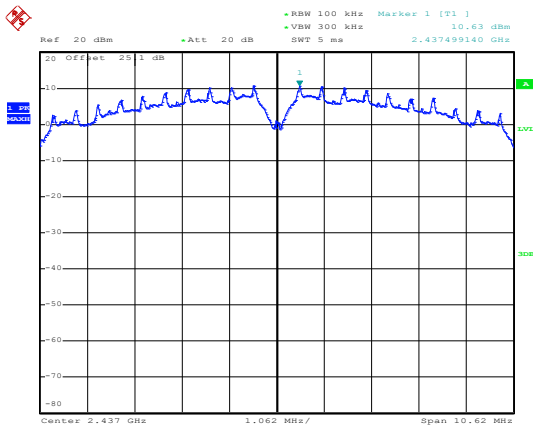

Date: 27.MAR.2014 10:22:58

Spurious Emission 30MHz~3GHz

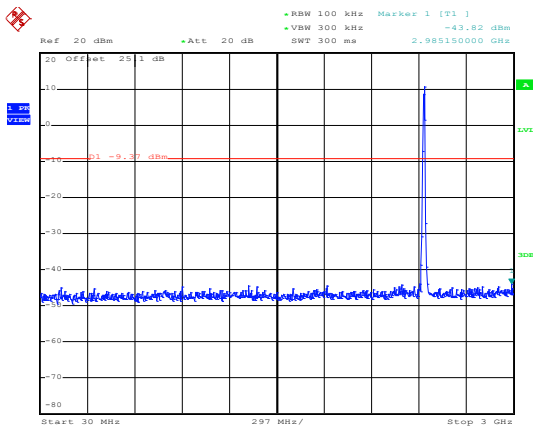

Date: 27.MAR.2014 10:23:20

Spurious Emission 2GHz~25GHz

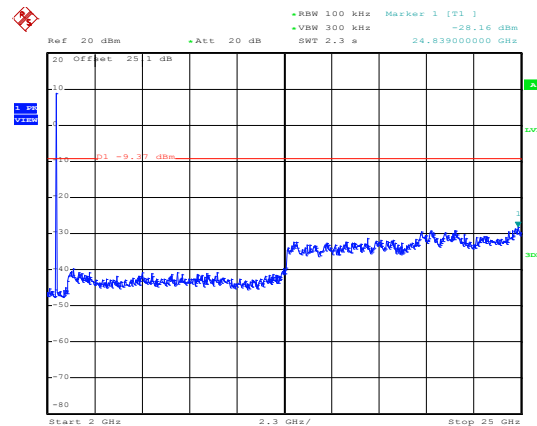

Date: 27.MAR.2014 10:23:39



Test Mode :	802.11b	Temperature :	21~25°C
Test Band :	2.4GHz High	Relative Humidity :	51~54%
Test Channel :	11	Test Engineer :	Kenny Chen

WLAN 802.11b Channel 11

100kHz PSD reference Level

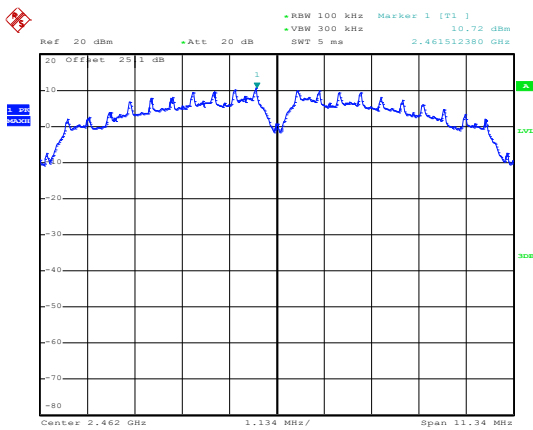

Date: 27.MAR.2014 10:26:52

High Channel Plot

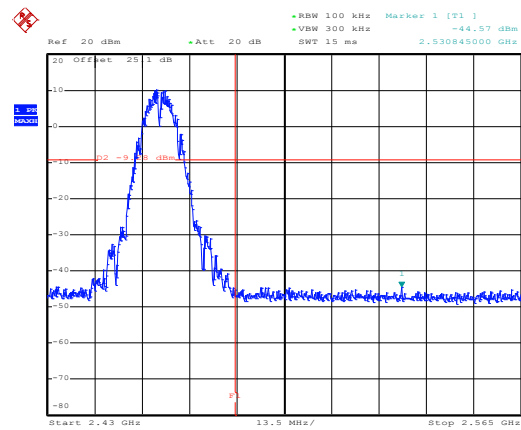

Date: 27.MAR.2014 10:27:34

Spurious Emission 30MHz~3GHz

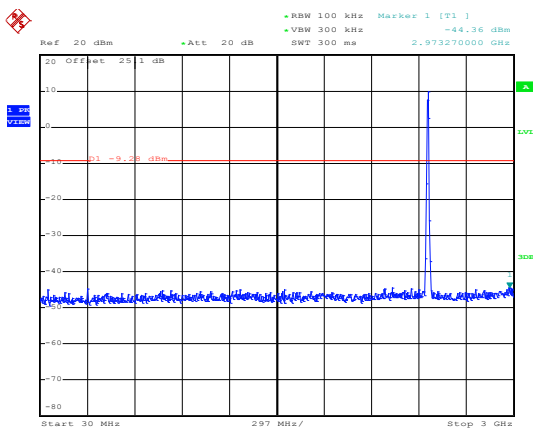

Date: 27.MAR.2014 10:27:57

Spurious Emission 2GHz~25GHz

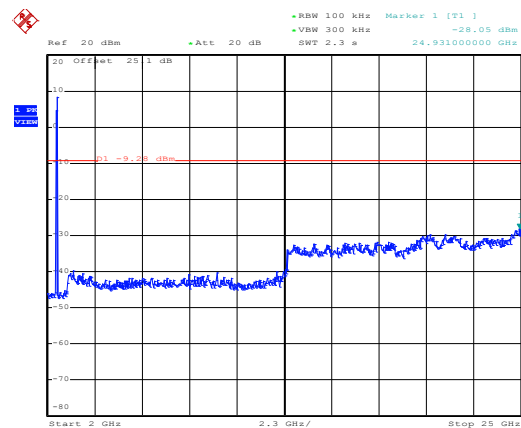

Date: 27.MAR.2014 10:28:15



Test Mode :	802.11g	Temperature :	21~25°C
Test Band :	2.4GHz Low	Relative Humidity :	51~54%
Test Channel :	01	Test Engineer :	Kenny Chen

WLAN 802.11g Channel 01

100kHz PSD reference Level

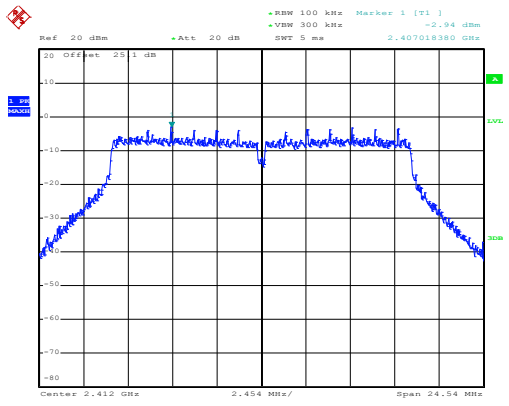

Date: 3.APR.2014 18:09:30

Low Channel Plot

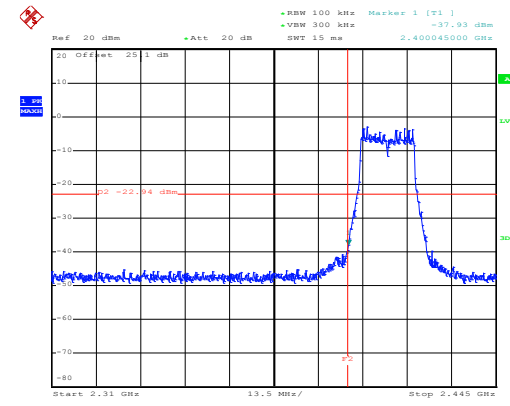

Date: 3.APR.2014 18:09:48

Spurious Emission 30MHz~3GHz

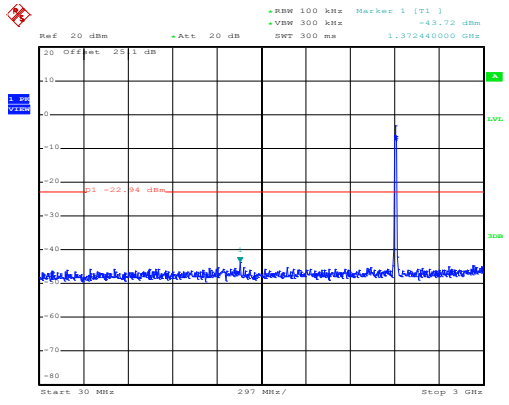

Date: 3.APR.2014 18:10:08

Spurious Emission 2GHz~25GHz

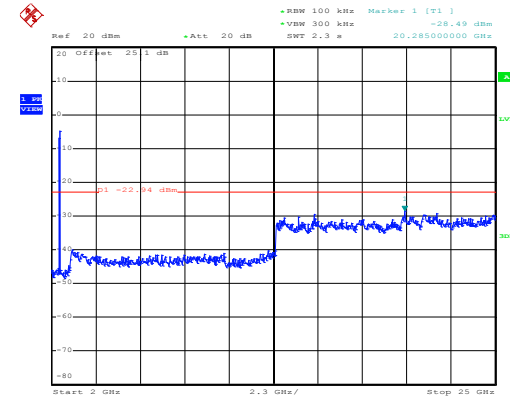

Date: 3.APR.2014 18:10:26



Test Mode :	802.11g	Temperature :	21~25°C
Test Band :	2.4GHz Mid	Relative Humidity :	51~54%
Test Channel :	06	Test Engineer :	Kenny Chen

WLAN 802.11g Channel 06

100kHz PSD reference Level

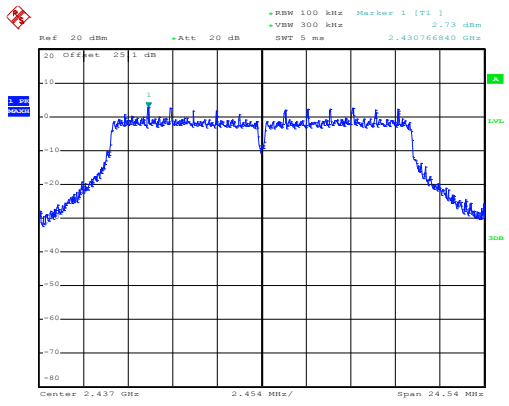

Date: 3.APR.2014 18:13:58

Spurious Emission 30MHz~3GHz **Spurious Emission 2GHz~25GHz**

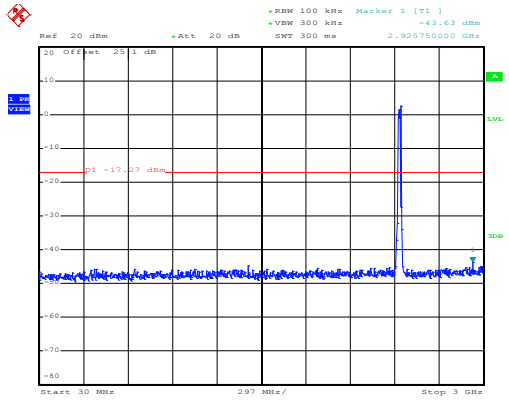

Date: 3.APR.2014 18:14:30

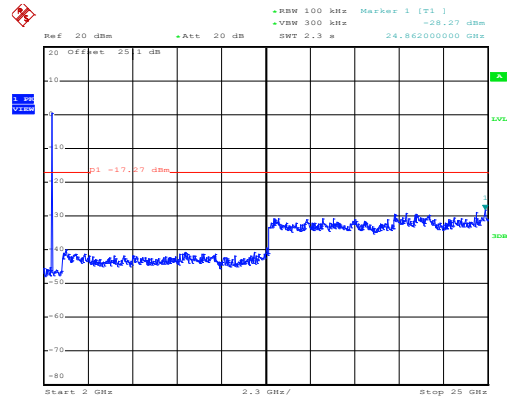

Date: 3.APR.2014 18:14:48



Test Mode :	802.11g	Temperature :	21~25°C
Test Band :	2.4GHz High	Relative Humidity :	51~54%
Test Channel :	11	Test Engineer :	Kenny Chen

WLAN 802.11g Channel 11

100kHz PSD reference Level

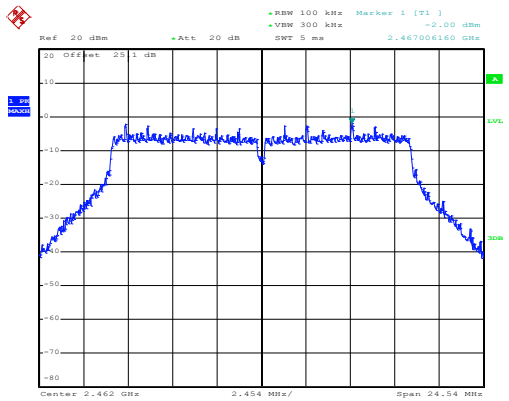

Date: 3.APR.2014 18:20:33

High Channel Plot

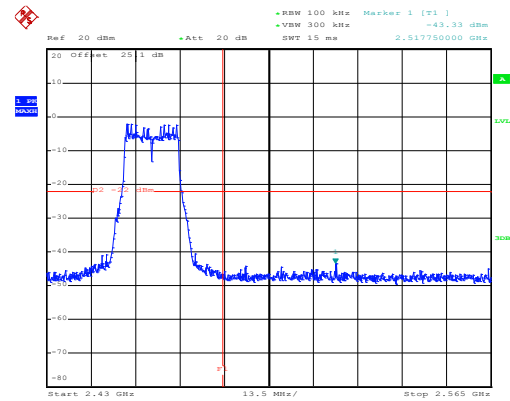

Date: 3.APR.2014 18:21:00

Spurious Emission 30MHz~3GHz

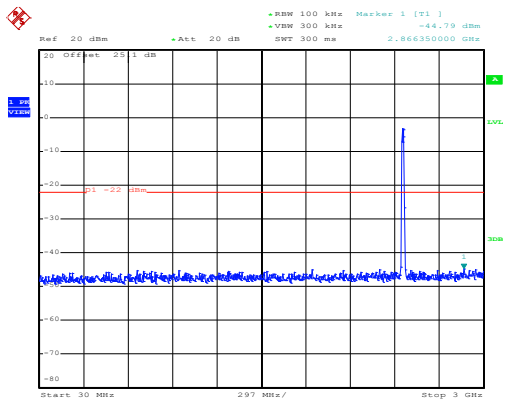

Date: 3.APR.2014 18:21:23

Spurious Emission 2GHz~25GHz

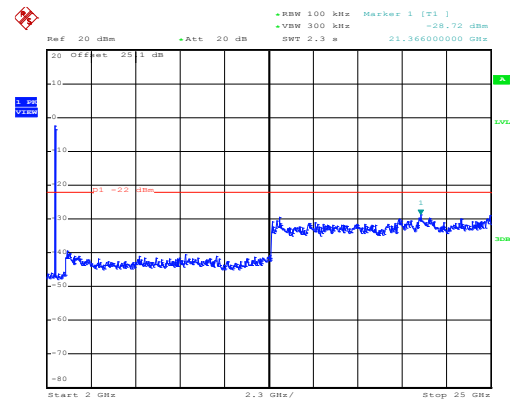

Date: 3.APR.2014 18:21:42



Test Mode :	802.11n HT20	Temperature :	21~25°C
Test Band :	2.4GHz Low	Relative Humidity :	51~54%
Test Channel :	01	Test Engineer :	Kenny Chen

WLAN 802.11n HT20 Channel 01

100kHz PSD reference Level

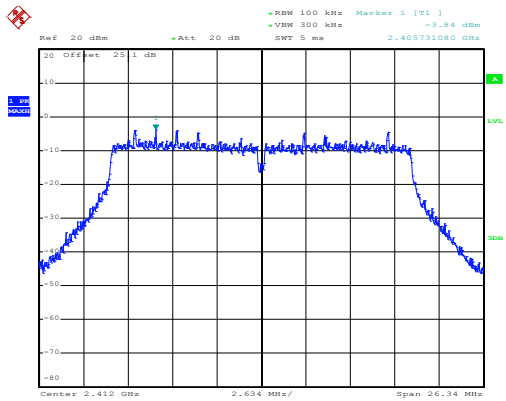

Date: 3.APR.2014 18:24:13

Low Channel Plot

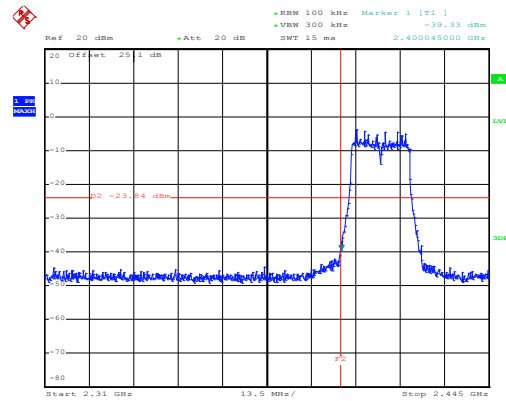

Date: 3.APR.2014 18:24:28

Spurious Emission 30MHz~3GHz

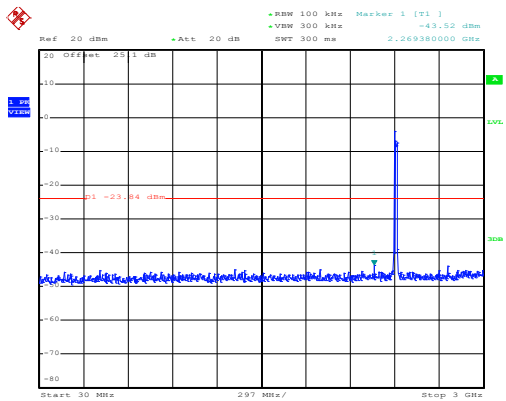

Date: 3.APR.2014 18:24:49

Spurious Emission 2GHz~25GHz

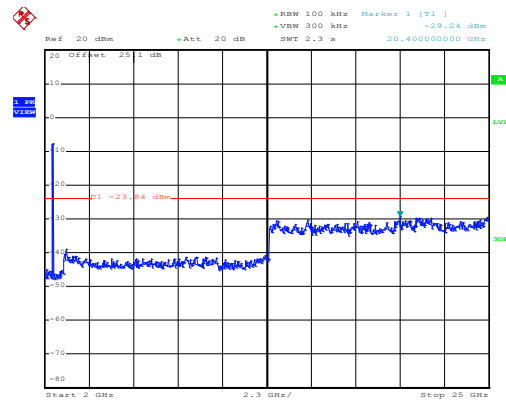

Date: 3.APR.2014 18:25:08



Test Mode :	802.11n HT20	Temperature :	21~25°C
Test Band :	2.4GHz Mid	Relative Humidity :	51~54%
Test Channel :	06	Test Engineer :	Kenny Chen

WLAN 802.11n HT20 Channel 06

100kHz PSD reference Level

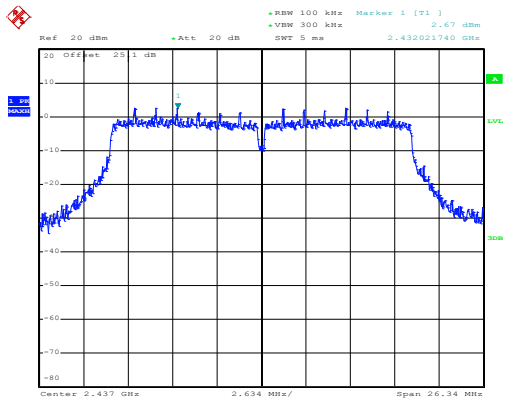

Date: 3.APR.2014 18:27:16

Spurious Emission 30MHz~3GHz **Spurious Emission 2GHz~25GHz**

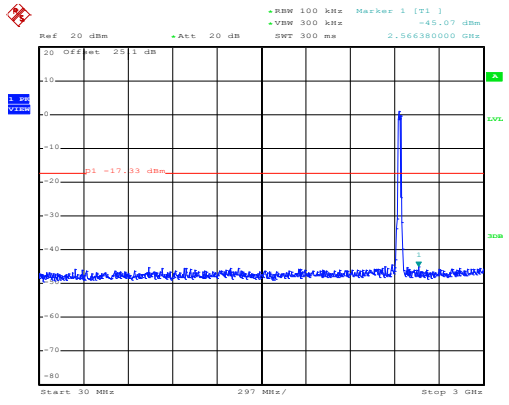

Date: 3.APR.2014 18:27:37

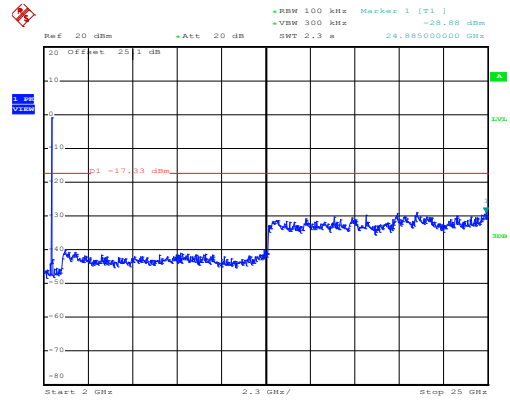

Date: 3.APR.2014 18:27:56



Test Mode :	802.11n HT20	Temperature :	21~25°C
Test Band :	2.4GHz High	Relative Humidity :	51~54%
Test Channel :	11	Test Engineer :	Kenny Chen

WLAN 802.11n HT20 Channel 11

100kHz PSD reference Level

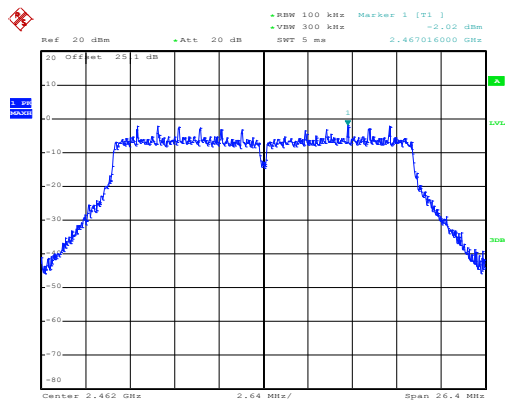

Date: 3.APR.2014 18:30:08

High Channel Plot

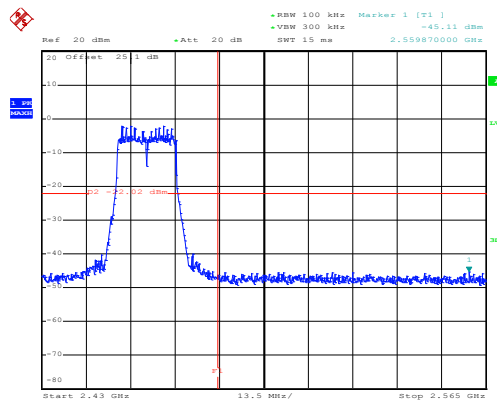

Date: 3.APR.2014 18:30:24

Spurious Emission 30MHz~3GHz

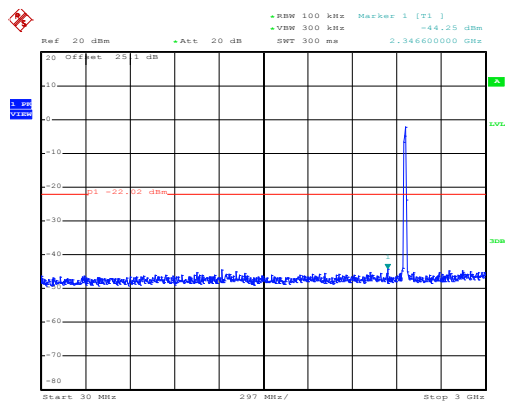

Date: 3.APR.2014 18:31:00

Spurious Emission 2GHz~25GHz

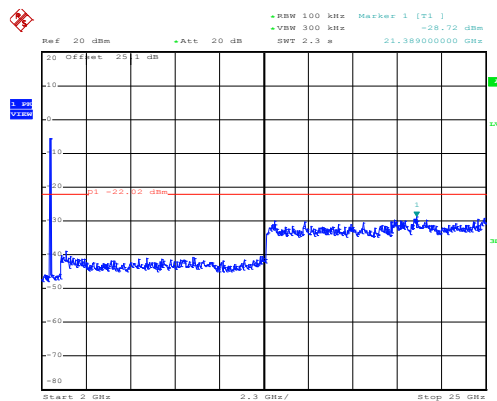

Date: 3.APR.2014 18:31:18



3.5 Radiated Band Edges and Spurious Emission Measurement

3.5.1 Limit of Radiated band edge and Spurious Emission Measurement

In any 100 kHz bandwidth outside the intentional radiator frequency band, all harmonics/spurious must be at least 20 dB below the highest emission level within the authorized band. If the output power of this device was measured by spectrum analyzer, the attenuation under this paragraph shall be 30 dB instead of 20 dB. In addition, radiated emissions which fall in the restricted bands must also comply with the FCC section 15.209 limits as below.

Frequency (MHz)	Field Strength (microvolts/meter)	Measurement Distance (meters)
0.009 – 0.490	2400/F(kHz)	300
0.490 – 1.705	24000/F(kHz)	30
1.705 – 30.0	30	30
30 – 88	100	3
88 – 216	150	3
216 - 960	200	3
Above 960	500	3

3.5.2 Measuring Instruments

The measuring equipment is listed in the section 4 of this test report.



3.5.3 Test Procedures

1. The testing follows FCC KDB Publication No. 558074 D01 DTS Meas. Guidance v03r01.
2. The EUT was arranged to its worst case and then tune the antenna tower (from 1 m to 4 m) and turntable (from 0 degree to 360 degrees) to find the maximum reading. A pre-amp and a high pass filter are used for the test in order to get better signal level.
3. The EUT was placed on a turntable with 0.8 meter above ground.
4. The EUT was set 3 meters from the interference receiving antenna, which was mounted on the top of a variable height antenna tower.
5. Corrected Reading: Antenna Factor + Cable Loss + Read Level - Preamp Factor = Level
6. For measurement below 1GHz, If the emission level of the EUT measured by the peak detector is 3 dB lower than the applicable limit, the peak emission level will be reported. Otherwise, the emission measurement will be repeated using the quasi-peak detector and reported.
7. Use the following spectrum analyzer settings:
 - (1) Span shall wide enough to fully capture the emission being measured;
 - (2) Set RBW=100 kHz for f < 1 GHz; VBW ≥ RBW; Sweep = auto; Detector function = peak; Trace = max hold;
 - (3) Set RBW = 1 MHz, VBW= 3MHz for f ≥ 1 GHz for peak measurement.

For average measurement:

 - VBW = 10 Hz, when duty cycle is no less than 98 percent.
 - VBW ≥ 1/T, when duty cycle is less than 98 percent where T is the minimum transmission duration over which the transmitter is on and is transmitting at its maximum power control level for the tested mode of operation.

Band	Duty Cycle(%)	T(μs)	1/T(kHz)	VBW Setting
802.11b	97.63	8240	0.12	1kHz
802.11g	87.26	1370	0.73	1kHz
2.4GHz 802.11n HT20	86.49	1280	0.78	1kHz

3.5.4 Test Setup

For radiated emissions below 30MHz

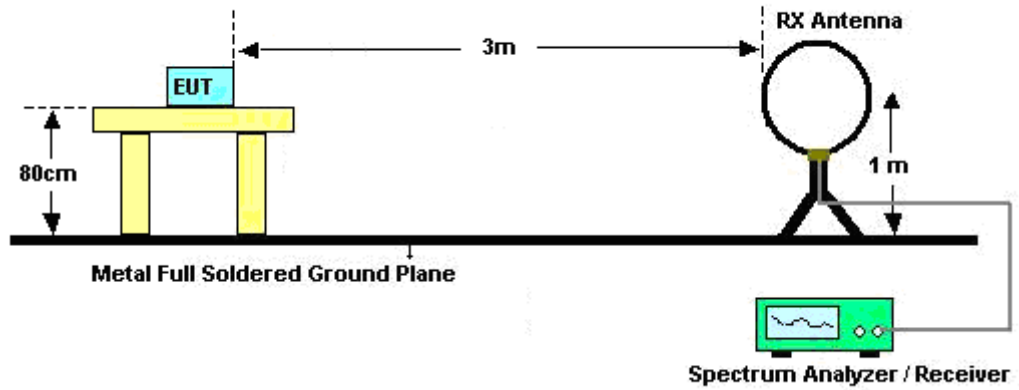

For radiated emissions from 30MHz to 1GHz

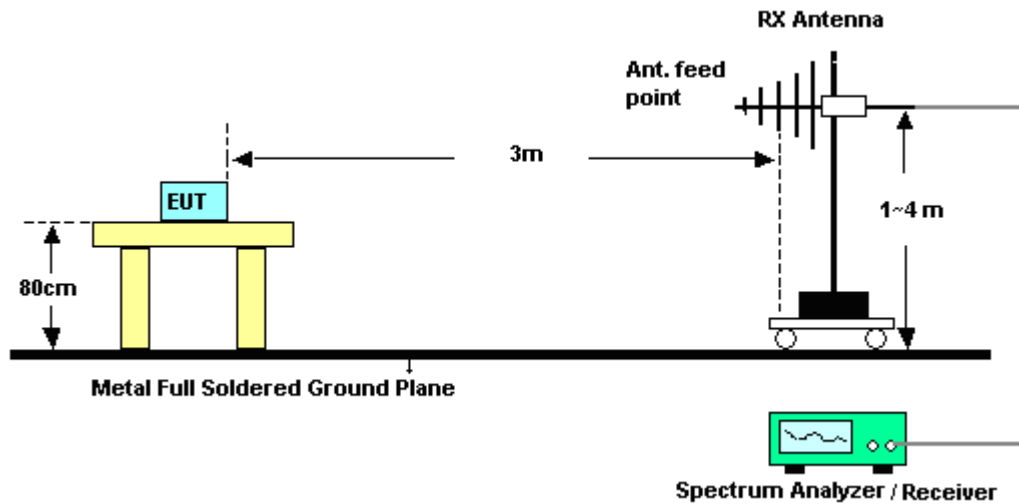

For radiated emissions above 1GHz

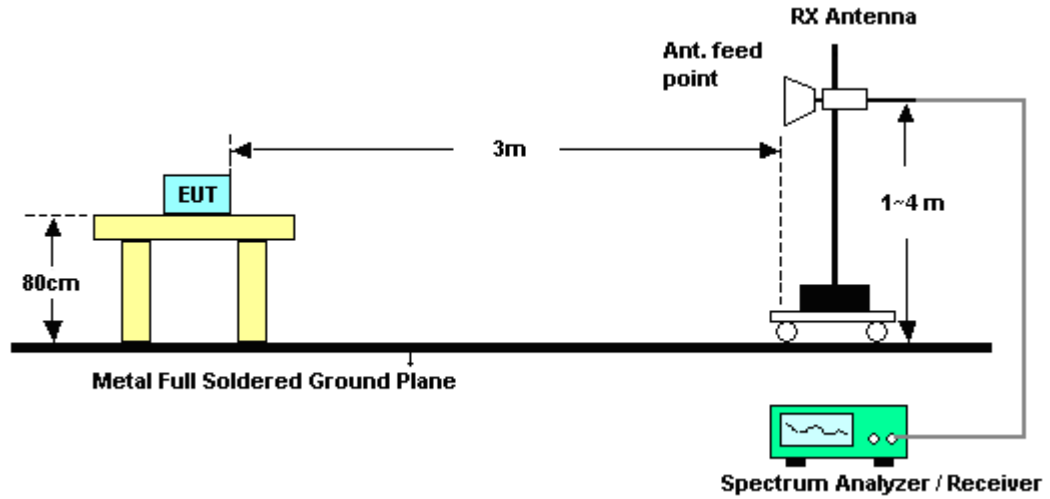

3.5.5 Test Results of Radiated Spurious Emissions (9kHz ~ 30MHz)

The low frequency, which started from 9 kHz to 30MHz, was pre-scanned and the result which was 20dB lower than the limit line per 15.31(o) was not reported.



3.5.6 Test Result of Radiated Spurious at Band Edges

Test Mode :	802.11b	Temperature :	22~24°C
Test Band :	Low	Relative Humidity :	47~49%
Test Channel :	01	Test Engineer :	Marlboro Hsu

ANTENNA POLARITY : HORIZONTAL										
Frequency (MHz)	Level (dBμV/m)	Over Limit (dB)	Limit Line (dBμV/m)	Read Level (dBμV)	Antenna Factor (dB)	Cable Loss (dB)	Preamp Factor (dB)	Ant Pos (cm)	Table Pos (deg)	Remark
2389.65	60.1	-13.9	74	55.16	32.3	6.91	34.27	100	2	Peak
2389.38	51.75	-2.25	54	46.81	32.3	6.91	34.27	100	2	Average

ANTENNA POLARITY : VERTICAL										
Frequency (MHz)	Level (dBμV/m)	Over Limit (dB)	Limit Line (dBμV/m)	Read Level (dBμV)	Antenna Factor (dB)	Cable Loss (dB)	Preamp Factor (dB)	Ant Pos (cm)	Table Pos (deg)	Remark
2331.87	57.02	-16.98	74	52.21	32.23	6.8	34.22	133	269	Peak
2389.92	45.13	-8.87	54	40.22	32.3	6.91	34.3	133	269	Average

Test Mode :	802.11b	Temperature :	22~24°C
Test Band :	High	Relative Humidity :	47~49%
Test Channel :	11	Test Engineer :	Marlboro Hsu

ANTENNA POLARITY : HORIZONTAL										
Frequency (MHz)	Level (dBμV/m)	Over Limit (dB)	Limit Line (dBμV/m)	Read Level (dBμV)	Antenna Factor (dB)	Cable Loss (dB)	Preamp Factor (dB)	Ant Pos (cm)	Table Pos (deg)	Remark
2498.98	59.28	-14.72	74	54.3	32.4	7.06	34.48	100	360	Peak
2483.53	45.79	-8.21	54	40.78	32.38	7.06	34.43	100	360	Average

ANTENNA POLARITY : VERTICAL										
Frequency (MHz)	Level (dBμV/m)	Over Limit (dB)	Limit Line (dBμV/m)	Read Level (dBμV)	Antenna Factor (dB)	Cable Loss (dB)	Preamp Factor (dB)	Ant Pos (cm)	Table Pos (deg)	Remark
2483.89	58.54	-15.46	74	53.53	32.38	7.06	34.43	101	239	Peak
2483.5	45.83	-8.17	54	40.82	32.38	7.06	34.43	101	239	Average



Test Mode :	802.11g	Temperature :	22~24°C
Test Band :	Low	Relative Humidity :	47~49%
Test Channel :	01	Test Engineer :	Marlboro Hsu

ANTENNA POLARITY : HORIZONTAL										
Frequency (MHz)	Level (dBμV/m)	Over Limit (dB)	Limit Line (dBμV/m)	Read Level (dBμV)	Antenna Factor (dB)	Cable Loss (dB)	Preamp Factor (dB)	Ant Pos (cm)	Table Pos (deg)	Remark
2389.65	58.96	-15.04	74	54.02	32.3	6.91	34.27	123	174	Peak
2389.83	44.93	-9.07	54	40.02	32.3	6.91	34.3	123	174	Average

ANTENNA POLARITY : VERTICAL										
Frequency (MHz)	Level (dBμV/m)	Over Limit (dB)	Limit Line (dBμV/m)	Read Level (dBμV)	Antenna Factor (dB)	Cable Loss (dB)	Preamp Factor (dB)	Ant Pos (cm)	Table Pos (deg)	Remark
2389.92	57.32	-16.68	74	52.41	32.3	6.91	34.3	131	336	Peak
2390	44.55	-9.45	54	39.64	32.3	6.91	34.3	131	336	Average

Test Mode :	802.11g	Temperature :	22~24°C
Test Band :	High	Relative Humidity :	47~49%
Test Channel :	11	Test Engineer :	Marlboro Hsu

ANTENNA POLARITY : HORIZONTAL										
Frequency (MHz)	Level (dBμV/m)	Over Limit (dB)	Limit Line (dBμV/m)	Read Level (dBμV)	Antenna Factor (dB)	Cable Loss (dB)	Preamp Factor (dB)	Ant Pos (cm)	Table Pos (deg)	Remark
2483.92	60.44	-13.56	74	55.43	32.38	7.06	34.43	118	21	Peak
2483.68	45.27	-8.73	54	40.26	32.38	7.06	34.43	118	21	Average

ANTENNA POLARITY : VERTICAL										
Frequency (MHz)	Level (dBμV/m)	Over Limit (dB)	Limit Line (dBμV/m)	Read Level (dBμV)	Antenna Factor (dB)	Cable Loss (dB)	Preamp Factor (dB)	Ant Pos (cm)	Table Pos (deg)	Remark
2484.91	60.2	-13.8	74	55.19	32.38	7.06	34.43	152	288	Peak
2483.98	44.88	-9.12	54	39.87	32.38	7.06	34.43	152	288	Average



Test Mode :	802.11n HT20	Temperature :	22~24°C
Test Band :	Low	Relative Humidity :	47~49%
Test Channel :	01	Test Engineer :	Marlboro Hsu

ANTENNA POLARITY : HORIZONTAL										
Frequency (MHz)	Level (dBμV/m)	Over Limit (dB)	Limit Line (dBμV/m)	Read Level (dBμV)	Antenna Factor (dB)	Cable Loss (dB)	Preamp Factor (dB)	Ant Pos (cm)	Table Pos (deg)	Remark
2389.02	58.35	-15.65	74	53.41	32.3	6.91	34.27	126	164	Peak
2389.83	45.19	-8.81	54	40.28	32.3	6.91	34.3	126	164	Average

ANTENNA POLARITY : VERTICAL										
Frequency (MHz)	Level (dBμV/m)	Over Limit (dB)	Limit Line (dBμV/m)	Read Level (dBμV)	Antenna Factor (dB)	Cable Loss (dB)	Preamp Factor (dB)	Ant Pos (cm)	Table Pos (deg)	Remark
2355.45	56.5	-17.5	74	51.65	32.26	6.84	34.25	155	229	Peak
2389.92	43.74	-10.26	54	38.83	32.3	6.91	34.3	155	229	Average

Test Mode :	802.11n HT20	Temperature :	22~24°C
Test Band :	High	Relative Humidity :	47~49%
Test Channel :	11	Test Engineer :	Marlboro Hsu

ANTENNA POLARITY : HORIZONTAL										
Frequency (MHz)	Level (dBμV/m)	Over Limit (dB)	Limit Line (dBμV/m)	Read Level (dBμV)	Antenna Factor (dB)	Cable Loss (dB)	Preamp Factor (dB)	Ant Pos (cm)	Table Pos (deg)	Remark
2484.04	63.69	-10.31	74	58.68	32.38	7.06	34.43	119	0	Peak
2483.5	45.59	-8.41	54	40.58	32.38	7.06	34.43	119	0	Average

ANTENNA POLARITY : VERTICAL										
Frequency (MHz)	Level (dBμV/m)	Over Limit (dB)	Limit Line (dBμV/m)	Read Level (dBμV)	Antenna Factor (dB)	Cable Loss (dB)	Preamp Factor (dB)	Ant Pos (cm)	Table Pos (deg)	Remark
2483.5	60.62	-13.38	74	55.61	32.38	7.06	34.43	102	328	Peak
2483.65	44.87	-9.13	54	39.86	32.38	7.06	34.43	102	328	Average



3.5.7 Test Result of Radiated Spurious Emission (30MHz ~ 10th Harmonic)

Note: Pre-scanned all test modes and only choose the worst case mode recorded in the test report for radiated spurious emission below 1GHz.

Test Mode :	802.11b	Temperature :	22~24°C
Test Channel :	01	Relative Humidity :	47~49%
Test Engineer :	Marlboro Hsu	Polarization :	Horizontal
Remark :	1. 2412 MHz is fundamental signal which can be ignored. 2. Average measurement was not performed if peak level went lower than the average limit.		

Frequency (MHz)	Level (dBμV/m)	Over Limit (dB)	Limit Line (dBμV/m)	Read Level (dBμV)	Antenna Factor (dB)	Cable Loss (dB)	Preamp Factor (dB)	Ant Pos (cm)	Table Pos (deg)	Remark
73.47	10.55	-29.45	40	34.2	6.72	0.85	31.22	-	-	Peak
118.29	16.2	-27.3	43.5	34.93	11.29	1.09	31.11	-	-	Peak
204.96	18.85	-24.65	43.5	39.46	9.15	1.34	31.1	-	-	Peak
345.5	36.12	-9.88	46	50.97	14.25	1.93	31.03	-	-	Peak
467.3	39.36	-6.64	46	50.35	17.47	2.34	30.8	-	-	Peak
591.9	40.41	-5.59	46	48.85	19.52	2.67	30.63	100	14	Peak
2412	109.67	-	-	104.71	32.31	6.95	34.3	100	2	Average
2412	113.47	-	-	108.51	32.31	6.95	34.3	100	2	Peak
4824	45.52	-28.48	74	61.71	33.97	8.77	58.93	100	0	Peak



Test Mode :	802.11b	Temperature :	22~24°C
Test Channel :	01	Relative Humidity :	47~49%
Test Engineer :	Marlboro Hsu	Polarization :	Vertical
Remark :	1. 2412 MHz is fundamental signal which can be ignored. 2. Average measurement was not performed if peak level went lower than the average limit.		

Frequency (MHz)	Level (dBμV/m)	Over Limit (dB)	Limit Line (dBμV/m)	Read Level (dBμV)	Antenna Factor (dB)	Cable Loss (dB)	Preamp Factor (dB)	Ant Pos (cm)	Table Pos (deg)	Remark
62.67	15.06	-24.94	40	39.52	6	0.78	31.24	-	-	Peak
134.49	17.44	-26.06	43.5	35.87	11.5	1.17	31.1	-	-	Peak
271.92	24.7	-21.3	46	41.16	12.88	1.64	30.98	-	-	Peak
342	24.74	-21.26	46	39.68	14.16	1.91	31.01	-	-	Peak
543.6	39.44	-6.56	46	48.72	18.96	2.54	30.78	120	332	Peak
659.1	28.89	-17.11	46	36.21	20.3	2.86	30.48	-	-	Peak
2412	107.73	-	-	102.77	32.31	6.95	34.3	133	269	Average
2412	111.47	-	-	106.51	32.31	6.95	34.3	133	269	Peak
4824	44.69	-29.31	74	60.88	33.97	8.77	58.93	100	0	Peak



Test Mode :	802.11b	Temperature :	22~24°C
Test Channel :	06	Relative Humidity :	47~49%
Test Engineer :	Marlboro Hsu	Polarization :	Horizontal
Remark :	1. 2438 MHz is fundamental signal which can be ignored. 2. Average measurement was not performed if peak level went lower than the average limit.		

Frequency (MHz)	Level (dBμV/m)	Over Limit (dB)	Limit Line (dBμV/m)	Read Level (dBμV)	Antenna Factor (dB)	Cable Loss (dB)	Preamp Factor (dB)	Ant Pos (cm)	Table Pos (deg)	Remark
2438	109.38	-	-	104.39	32.35	6.99	34.35	148	170	Average
2438	113.23	-	-	108.24	32.35	6.99	34.35	148	170	Peak
4872	45.66	-28.34	74	61.72	33.95	8.82	58.83	100	0	Peak
7311	47.13	-26.87	74	58.41	35.54	10.91	57.73	100	0	Peak

Test Mode :	802.11b	Temperature :	22~24°C
Test Channel :	06	Relative Humidity :	47~49%
Test Engineer :	Marlboro Hsu	Polarization :	Vertical
Remark :	1. 2438 MHz is fundamental signal which can be ignored. 2. Average measurement was not performed if peak level went lower than the average limit.		

Frequency (MHz)	Level (dBμV/m)	Over Limit (dB)	Limit Line (dBμV/m)	Read Level (dBμV)	Antenna Factor (dB)	Cable Loss (dB)	Preamp Factor (dB)	Ant Pos (cm)	Table Pos (deg)	Remark
2438	107.67	-	-	102.68	32.35	6.99	34.35	129	269	Average
2438	111.29	-	-	106.3	32.35	6.99	34.35	129	269	Peak
4875	43.31	-30.69	74	59.37	33.95	8.82	58.83	100	0	Peak
7311	45.2	-28.8	74	56.48	35.54	10.91	57.73	100	0	Peak



Test Mode :	802.11b	Temperature :	22~24°C
Test Channel :	11	Relative Humidity :	47~49%
Test Engineer :	Marlboro Hsu	Polarization :	Horizontal
Remark :	1. 2462 MHz is fundamental signal which can be ignored. 2. Average measurement was not performed if peak level went lower than the average limit.		

Frequency (MHz)	Level (dBμV/m)	Over Limit (dB)	Limit Line (dBμV/m)	Read Level (dBμV)	Antenna Factor (dB)	Cable Loss (dB)	Preamp Factor (dB)	Ant Pos (cm)	Table Pos (deg)	Remark
2462	107.5	-	-	102.5	32.37	7.02	34.39	100	360	Average
2462	111.2	-	-	106.2	32.37	7.02	34.39	100	360	Peak
4923	42.76	-31.24	74	58.69	33.93	8.87	58.73	100	0	Peak
7386	45.45	-28.55	74	56.74	35.52	10.99	57.8	100	0	Peak

Test Mode :	802.11b	Temperature :	22~24°C
Test Channel :	11	Relative Humidity :	47~49%
Test Engineer :	Marlboro Hsu	Polarization :	Vertical
Remark :	1. 2462 MHz is fundamental signal which can be ignored. 2. Average measurement was not performed if peak level went lower than the average limit.		

Frequency (MHz)	Level (dBμV/m)	Over Limit (dB)	Limit Line (dBμV/m)	Read Level (dBμV)	Antenna Factor (dB)	Cable Loss (dB)	Preamp Factor (dB)	Ant Pos (cm)	Table Pos (deg)	Remark
2462	105.46	-	-	100.46	32.37	7.02	34.39	101	239	Average
2462	109.08	-	-	104.08	32.37	7.02	34.39	101	239	Peak
4923	40.42	-33.58	74	56.35	33.93	8.87	58.73	100	0	Peak
7386	44.7	-29.3	74	55.99	35.52	10.99	57.8	100	0	Peak



Test Mode :	802.11g	Temperature :	22~24°C
Test Channel :	01	Relative Humidity :	47~49%
Test Engineer :	Marlboro Hsu	Polarization :	Horizontal
Remark :	1. 2414 MHz is fundamental signal which can be ignored. 2. Average measurement was not performed if peak level went lower than the average limit.		

Frequency (MHz)	Level (dBμV/m)	Over Limit (dB)	Limit Line (dBμV/m)	Read Level (dBμV)	Antenna Factor (dB)	Cable Loss (dB)	Preamp Factor (dB)	Ant Pos (cm)	Table Pos (deg)	Remark
2414	94.34	-	-	89.38	32.31	6.95	34.3	123	174	Average
2414	104.43	-	-	99.47	32.31	6.95	34.3	123	174	Peak
4824	40.29	-33.71	74	56.48	33.97	8.77	58.93	100	0	Peak

Test Mode :	802.11g	Temperature :	22~24°C
Test Channel :	01	Relative Humidity :	47~49%
Test Engineer :	Marlboro Hsu	Polarization :	Vertical
Remark :	1. 2410 MHz is fundamental signal which can be ignored. 2. Average measurement was not performed if peak level went lower than the average limit.		

Frequency (MHz)	Level (dBμV/m)	Over Limit (dB)	Limit Line (dBμV/m)	Read Level (dBμV)	Antenna Factor (dB)	Cable Loss (dB)	Preamp Factor (dB)	Ant Pos (cm)	Table Pos (deg)	Remark
2410	92.82	-	-	87.86	32.31	6.95	34.3	131	336	Average
2410	102.65	-	-	97.69	32.31	6.95	34.3	131	336	Peak
4824	40.12	-33.88	74	56.31	33.97	8.77	58.93	100	0	Peak



Test Mode :	802.11g	Temperature :	22~24°C
Test Channel :	06	Relative Humidity :	47~49%
Test Engineer :	Marlboro Hsu	Polarization :	Horizontal
Remark :	1. 2435 MHz is fundamental signal which can be ignored. 2. Average measurement was not performed if peak level went lower than the average limit.		

Frequency (MHz)	Level (dBμV/m)	Over Limit (dB)	Limit Line (dBμV/m)	Read Level (dBμV)	Antenna Factor (dB)	Cable Loss (dB)	Preamp Factor (dB)	Ant Pos (cm)	Table Pos (deg)	Remark
2435	101.61	-	-	96.64	32.33	6.99	34.35	147	154	Average
2435	111.53	-	-	106.56	32.33	6.99	34.35	147	154	Peak
4875	44.73	-29.27	74	60.79	33.95	8.82	58.83	100	0	Peak
7311	42.94	-31.06	74	54.22	35.54	10.91	57.73	100	0	Peak

Test Mode :	802.11g	Temperature :	22~24°C
Test Channel :	06	Relative Humidity :	47~49%
Test Engineer :	Marlboro Hsu	Polarization :	Vertical
Remark :	1. 2439 MHz is fundamental signal which can be ignored. 2. Average measurement was not performed if peak level went lower than the average limit.		

Frequency (MHz)	Level (dBμV/m)	Over Limit (dB)	Limit Line (dBμV/m)	Read Level (dBμV)	Antenna Factor (dB)	Cable Loss (dB)	Preamp Factor (dB)	Ant Pos (cm)	Table Pos (deg)	Remark
2439	98.04	-	-	93.05	32.35	6.99	34.35	103	241	Average
2439	107.68	-	-	102.69	32.35	6.99	34.35	103	241	Peak
4875	39.98	-34.02	74	56.04	33.95	8.82	58.83	100	0	Peak
7311	41.9	-32.1	74	53.18	35.54	10.91	57.73	100	0	Peak



Test Mode :	802.11g	Temperature :	22~24°C
Test Channel :	11	Relative Humidity :	47~49%
Test Engineer :	Marlboro Hsu	Polarization :	Horizontal
Remark :	1. 2462 MHz is fundamental signal which can be ignored. 2. Average measurement was not performed if peak level went lower than the average limit.		

Frequency (MHz)	Level (dBμV/m)	Over Limit (dB)	Limit Line (dBμV/m)	Read Level (dBμV)	Antenna Factor (dB)	Cable Loss (dB)	Preamp Factor (dB)	Ant Pos (cm)	Table Pos (deg)	Remark
2462	95.99	-	-	90.99	32.37	7.02	34.39	118	21	Average
2462	105.57	-	-	100.57	32.37	7.02	34.39	118	21	Peak
4923	41.57	-32.43	74	57.5	33.93	8.87	58.73	100	0	Peak
7386	41.71	-32.29	74	53	35.52	10.99	57.8	100	0	Peak



Test Mode :	802.11g	Temperature :	22~24°C
Test Channel :	11	Relative Humidity :	47~49%
Test Engineer :	Marlboro Hsu	Polarization :	Vertical
Remark :	1. 2460 MHz is fundamental signal which can be ignored. 2. Average measurement was not performed if peak level went lower than the average limit.		

Frequency (MHz)	Level (dBμV/m)	Over Limit (dB)	Limit Line (dBμV/m)	Read Level (dBμV)	Antenna Factor (dB)	Cable Loss (dB)	Preamp Factor (dB)	Ant Pos (cm)	Table Pos (deg)	Remark
2460	93.93	-	-	88.93	32.37	7.02	34.39	152	288	Average
2460	103.59	-	-	98.59	32.37	7.02	34.39	152	288	Peak
4923	40.52	-33.48	74	56.45	33.93	8.87	58.73	100	0	Peak
7386	41.49	-32.51	74	52.78	35.52	10.99	57.8	100	0	Peak



Test Mode :	2.4GHz 802.11n HT20	Temperature :	22~24°C
Test Channel :	01	Relative Humidity :	47~49%
Test Engineer :	Marlboro Hsu	Polarization :	Horizontal
Remark :	1. 2410 MHz is fundamental signal which can be ignored. 2. Average measurement was not performed if peak level went lower than the average limit.		

Frequency (MHz)	Level (dBμV/m)	Over Limit (dB)	Limit Line (dBμV/m)	Read Level (dBμV)	Antenna Factor (dB)	Cable Loss (dB)	Preamp Factor (dB)	Ant Pos (cm)	Table Pos (deg)	Remark
2410	93.73	-	-	88.77	32.31	6.95	34.3	126	164	Average
2410	103.07	-	-	98.11	32.31	6.95	34.3	126	164	Peak
4824	39.94	-34.06	74	56.13	33.97	8.77	58.93	100	0	Peak

Test Mode :	2.4GHz 802.11n HT20	Temperature :	22~24°C
Test Channel :	01	Relative Humidity :	47~49%
Test Engineer :	Marlboro Hsu	Polarization :	Vertical
Remark :	1. 2410 MHz is fundamental signal which can be ignored. 2. Average measurement was not performed if peak level went lower than the average limit.		

Frequency (MHz)	Level (dBμV/m)	Over Limit (dB)	Limit Line (dBμV/m)	Read Level (dBμV)	Antenna Factor (dB)	Cable Loss (dB)	Preamp Factor (dB)	Ant Pos (cm)	Table Pos (deg)	Remark
2410	91.15	-	-	86.19	32.31	6.95	34.3	155	229	Average
2410	101.36	-	-	96.4	32.31	6.95	34.3	155	229	Peak
4824	40.54	-33.46	74	56.73	33.97	8.77	58.93	100	0	Peak



Test Mode :	2.4GHz 802.11n HT20	Temperature :	22~24°C
Test Channel :	06	Relative Humidity :	47~49%
Test Engineer :	Marlboro Hsu	Polarization :	Horizontal
Remark :	1. 2439 MHz is fundamental signal which can be ignored. 2. Average measurement was not performed if peak level went lower than the average limit.		

Frequency (MHz)	Level (dBμV/m)	Over Limit (dB)	Limit Line (dBμV/m)	Read Level (dBμV)	Antenna Factor (dB)	Cable Loss (dB)	Preamp Factor (dB)	Ant Pos (cm)	Table Pos (deg)	Remark
2439	101.2	-	-	96.21	32.35	6.99	34.35	101	359	Average
2439	111.79	-	-	106.8	32.35	6.99	34.35	101	359	Peak
4872	45.34	-28.66	74	61.4	33.95	8.82	58.83	100	0	Peak
7311	42.7	-31.3	74	53.98	35.54	10.91	57.73	100	0	Peak

Test Mode :	2.4GHz 802.11n HT20	Temperature :	22~24°C
Test Channel :	06	Relative Humidity :	47~49%
Test Engineer :	Marlboro Hsu	Polarization :	Vertical
Remark :	1. 2439 MHz is fundamental signal which can be ignored. 2. Average measurement was not performed if peak level went lower than the average limit.		

Frequency (MHz)	Level (dBμV/m)	Over Limit (dB)	Limit Line (dBμV/m)	Read Level (dBμV)	Antenna Factor (dB)	Cable Loss (dB)	Preamp Factor (dB)	Ant Pos (cm)	Table Pos (deg)	Remark
2439	100.11	-	-	95.12	32.35	6.99	34.35	131	273	Average
2439	110.87	-	-	105.88	32.35	6.99	34.35	131	273	Peak
4875	41.01	-32.99	74	57.07	33.95	8.82	58.83	100	0	Peak
7311	41.23	-32.77	74	52.51	35.54	10.91	57.73	100	0	Peak



Test Mode :	2.4GHz 802.11n HT20	Temperature :	22~24°C
Test Channel :	11	Relative Humidity :	47~49%
Test Engineer :	Marlboro Hsu	Polarization :	Horizontal
Remark :	1. 2460 MHz is fundamental signal which can be ignored. 2. Average measurement was not performed if peak level went lower than the average limit.		

Frequency (MHz)	Level (dBμV/m)	Over Limit (dB)	Limit Line (dBμV/m)	Read Level (dBμV)	Antenna Factor (dB)	Cable Loss (dB)	Preamp Factor (dB)	Ant Pos (cm)	Table Pos (deg)	Remark
55.38	20.56	-19.44	40	44.63	6.4	0.73	31.2	-	-	Peak
159.87	25.6	-17.9	43.5	45.08	10.5	1.22	31.2	-	-	Peak
294.6	35.02	-10.98	46	51.19	13.15	1.73	31.05	-	-	Peak
348.3	37.42	-8.58	46	52.16	14.34	1.96	31.04	-	-	Peak
467.3	39.36	-6.64	46	50.35	17.47	2.34	30.8	152	123	Peak
797	24.82	-21.18	46	30.02	21.97	3.14	30.31	-	-	Peak
2460	95.19	-	-	90.19	32.37	7.02	34.39	119	0	Average
2460	105.44	-	-	100.44	32.37	7.02	34.39	119	0	Peak
4923	42.02	-31.98	74	57.95	33.93	8.87	58.73	100	0	Peak
7386	41.63	-32.37	74	52.92	35.52	10.99	57.8	100	0	Peak



Test Mode :	2.4GHz 802.11n HT20	Temperature :	22~24°C
Test Channel :	11	Relative Humidity :	47~49%
Test Engineer :	Marlboro Hsu	Polarization :	Vertical
Remark :	1. 2460 MHz is fundamental signal which can be ignored. 2. Average measurement was not performed if peak level went lower than the average limit.		

Frequency (MHz)	Level (dBμV/m)	Over Limit (dB)	Limit Line (dBμV/m)	Read Level (dBμV)	Antenna Factor (dB)	Cable Loss (dB)	Preamp Factor (dB)	Ant Pos (cm)	Table Pos (deg)	Remark
76.71	21.79	-18.21	40	45.26	6.87	0.86	31.2	-	-	Peak
182.55	21.25	-22.25	43.5	42.09	8.86	1.26	30.96	-	-	Peak
268.95	28.92	-17.08	46	45.28	13.01	1.63	31	-	-	Peak
354.6	28.65	-17.35	46	43.15	14.55	2.02	31.07	-	-	Peak
512.1	38.04	-7.96	46	48.12	18.1	2.47	30.65	-	-	Peak
608	39.56	-6.44	46	47.59	19.84	2.71	30.58	114	55	Peak
2460	92.16	-	-	87.16	32.37	7.02	34.39	102	328	Average
2460	101.5	-	-	96.5	32.37	7.02	34.39	102	328	Peak
4923	41.16	-32.84	74	57.09	33.93	8.87	58.73	100	0	Peak
7386	42.9	-31.1	74	54.19	35.52	10.99	57.8	100	0	Peak

3.6 AC Conducted Emission Measurement

3.6.1 Limit of AC Conducted Emission

For equipment that is designed to be connected to the public utility (AC) power line, the radio frequency voltage that is conducted back onto the AC power line on any frequency or frequencies within the band 150 kHz to 30 MHz shall not exceed the limits in the following table.

Frequency of Emission (MHz)	Conducted Limit (dB μ V)	
	Quasi-Peak	Average
0.15-0.5	66 to 56*	56 to 46*
0.5-5	56	46
5-30	60	50

*Decreases with the logarithm of the frequency.

3.6.2 Measuring Instruments

The measuring equipment is listed in the section 4 of this test report.

3.6.3 Test Procedures

1. The EUT was placed 0.4 meter from the conducting wall of the shielding room, and it was kept at least 80 centimeters from any other grounded conducting surface.
2. Connect EUT to the power mains through a line impedance stabilization network (LISN).
3. All the support units are connecting to the other LISN.
4. The LISN provides 50 ohm coupling impedance for the measuring instrument.
5. The FCC states that a 50 ohm, 50 microhenry LISN should be used.
6. Both sides of AC line were checked for maximum conducted interference.
7. The frequency range from 150 kHz to 30 MHz was searched.
8. Set the test-receiver system to Peak Detect Function and specified bandwidth with Maximum Hold Mode.

3.6.4 Test Setup

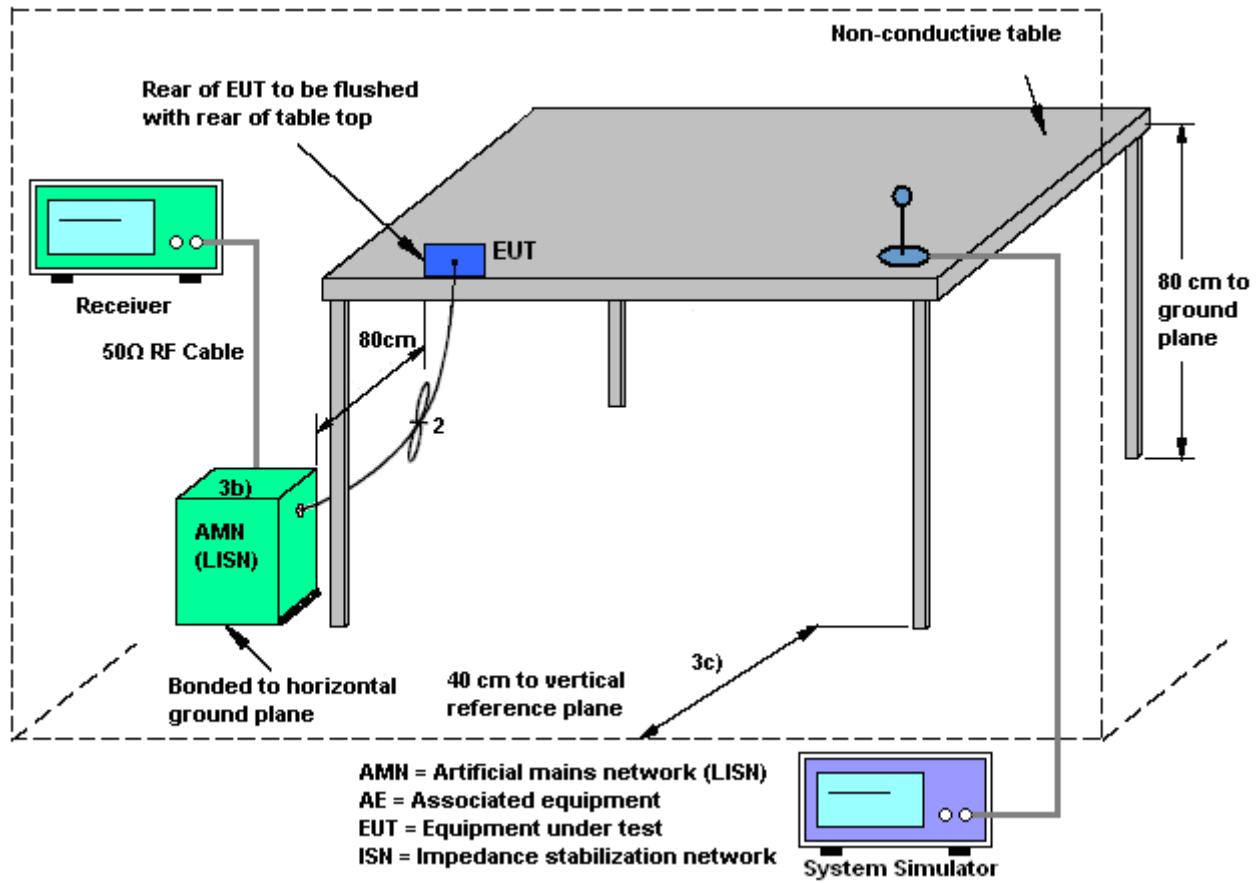

3.6.5 Test Result of AC Conducted Emission

Test Mode :	Mode 1	Temperature :	20~22°C
Test Engineer :	Cosmo Xu	Relative Humidity :	45~47%
Test Voltage :	120Vac / 60Hz	Phase :	Line
Function Type :	WCDMA Band II Idle + Bluetooth Link + WLAN Link + Camera + Earphone + Battery + Adapter		

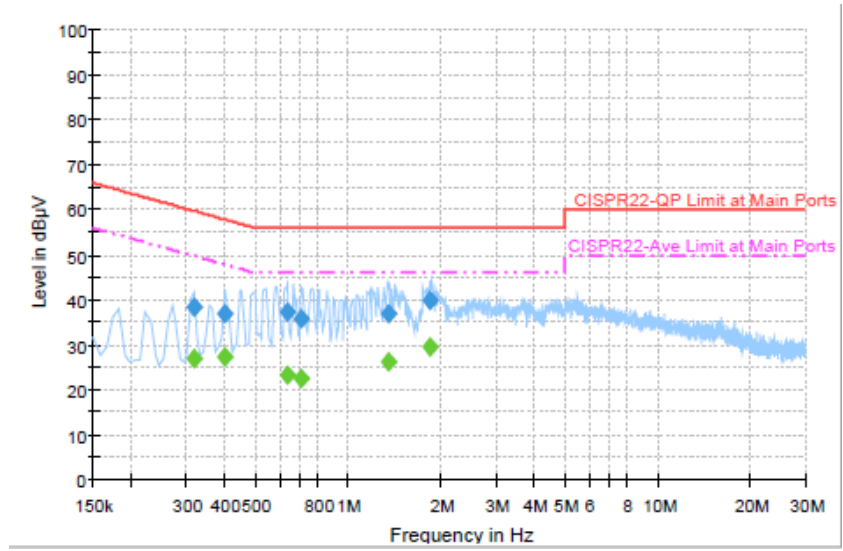

Final Result : Quasi-Peak

Frequency (MHz)	Quasi-Peak (dBµV)	Filter	Line	Corr. (dB)	Margin (dB)	Limit (dBµV)
0.318000	38.5	Off	L1	19.4	21.3	59.8
0.398000	37.0	Off	L1	19.3	20.9	57.9
0.638000	37.4	Off	L1	19.4	18.6	56.0
0.710000	35.9	Off	L1	19.5	20.1	56.0
1.358000	36.8	Off	L1	19.5	19.2	56.0
1.830000	39.9	Off	L1	19.6	16.1	56.0

Final Result : Average

Frequency (MHz)	Average (dBµV)	Filter	Line	Corr. (dB)	Margin (dB)	Limit (dBµV)
0.318000	27.0	Off	L1	19.4	22.8	49.8
0.398000	27.3	Off	L1	19.3	20.6	47.9
0.638000	23.3	Off	L1	19.4	22.7	46.0
0.710000	22.5	Off	L1	19.5	23.5	46.0
1.358000	26.0	Off	L1	19.5	20.0	46.0
1.830000	29.6	Off	L1	19.6	16.4	46.0



Test Mode :	Mode 1	Temperature :	20~22°C
Test Engineer :	Cosmo Xu	Relative Humidity :	45~47%
Test Voltage :	120Vac / 60Hz	Phase :	Neutral
Function Type :	WCDMA Band II Idle + Bluetooth Link + WLAN Link + Camera + Earphone + Battery + Adapter		

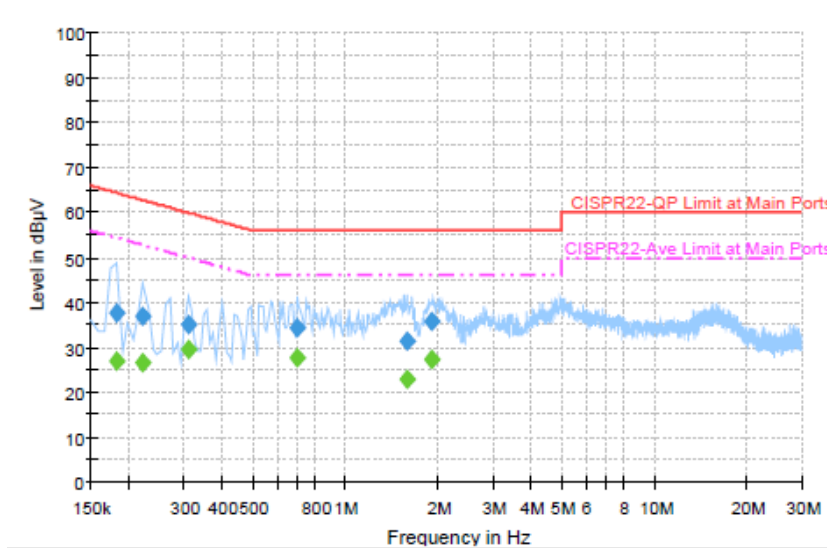

Final Result : Quasi-Peak

Frequency (MHz)	Quasi-Peak (dBµV)	Filter	Line	Corr. (dB)	Margin (dB)	Limit (dBµV)
0.182000	37.8	Off	N	19.3	26.6	64.4
0.222000	37.1	Off	N	19.4	25.6	62.7
0.310000	35.0	Off	N	19.3	25.0	60.0
0.702000	34.5	Off	N	19.5	21.5	56.0
1.582000	31.4	Off	N	19.5	24.6	56.0
1.902000	35.8	Off	N	19.6	20.2	56.0

Final Result : Average

Frequency (MHz)	Average (dBµV)	Filter	Line	Corr. (dB)	Margin (dB)	Limit (dBµV)
0.182000	27.1	Off	N	19.3	27.3	54.4
0.222000	26.6	Off	N	19.4	26.1	52.7
0.310000	29.3	Off	N	19.3	20.7	50.0
0.702000	27.6	Off	N	19.5	18.4	46.0
1.582000	22.9	Off	N	19.5	23.1	46.0
1.902000	27.2	Off	N	19.6	18.8	46.0



3.7 Antenna Requirements

3.7.1 Standard Applicable

If directional gain of transmitting antennas is greater than 6dBi, the power shall be reduced by the same level in dB comparing to gain minus 6dBi. For the fixed point-to-point operation, the power shall be reduced by one dB for every 3 dB that the directional gain of the antenna exceeds 6 dBi. The use of a permanently attached antenna or of an antenna that uses a unique coupling to the intentional radiator shall be considered sufficient to comply with the FCC rule.

3.7.2 Antenna Anti-Replacement Construction

An embedded-in antenna design is used.

3.7.3 Antenna Gain

The antenna peak gain of EUT is less than 6 dBi. Therefore, it is not necessary to reduce maximum peak output power limit.



4 List of Measuring Equipment

Instrument	Manufacturer	Model No.	Serial No.	Characteristics	Calibration Date	Test Date	Due Date	Remark
Spectrum Analyzer	Rohde & Schwarz	FSP40	100055	9kHz~40GHz	Jun. 07, 2013	Mar. 20, 2014~ Apr. 03, 2014	Jun. 06, 2014	Conducted (TH02-HY)
Power Meter	Anritsu	ML2495A	1036004	300MHz~40GHz	Aug. 17, 2013	Mar. 20, 2014~ Apr. 03, 2014	Aug. 16, 2014	Conducted (TH02-HY)
Power Sensor	Anritsu	MA2411B	1027253	300MHz~40GHz	Aug. 17, 2013	Mar. 20, 2014~ Apr. 03, 2014	Aug. 16, 2014	Conducted (TH02-HY)
EMI Test Receiver	Rohde & Schwarz	ESCI 7	100724	9 kHz~7 GHz	Sep. 06, 2013	Apr. 01, 2014~ Apr. 03, 2014	Sep. 05, 2014	Radiation (03CH07-HY)
Spectrum Analyzer	Rohde & Schwarz	FSP30	101067	9 kHz ~ 30 GHz	Nov. 20, 2013	Apr. 01, 2014~ Apr. 03, 2014	Nov. 19, 2014	Radiation (03CH07-HY)
Loop Antenna	Rohde & Schwarz	HFH2-Z2	860004/00 01	9 kHz~30 MHz	Jul. 03, 2012	Apr. 01, 2014~ Apr. 03, 2014	Jul. 03, 2014	Radiation (03CH07-HY)
Bilog Antenna	Schaffner	CBL6111C	2726	30 MHz ~ 1 GHz	Oct. 10, 2013	Apr. 01, 2014~ Apr. 03, 2014	Oct. 09, 2014	Radiation (03CH07-HY)
Double Ridge Horn Antenna	ESCO	3117	75962	1 GHz~18 GHz	Aug. 22, 2013	Apr. 01, 2014~ Apr. 03, 2014	Aug. 21, 2014	Radiation (03CH07-HY)
SHF-EHF Horn Antenna	SCHWARZBECK	BBHA 9170	BBHA9170 251	15 GHz- 40 GHz	Oct. 03, 2013	Apr. 01, 2014~ Apr. 03, 2014	Oct. 02, 2014	Radiation (03CH07-HY)
Preamplifier	SONOMA	310N	187231	9kHz~1GHz	May 15, 2013	Apr. 01, 2014~ Apr. 03, 2014	May 14, 2014	Radiation (03CH07-HY)
Preamplifier	Agilent	8449B	3008A023 62	1 GHz~26.5 GHz	Nov. 29, 2013	Apr. 01, 2014~ Apr. 03, 2014	Nov. 28, 2014	Radiation (03CH07-HY)
Preamplifier	EMCI	EMC051845	SN980048	EMCI	Jul. 18, 2013	Apr. 01, 2014~ Apr. 03, 2014	Jul. 17, 2014	Radiation (03CH07-HY)
Turn Table	ChainTek	ChainTek 3000	N/A	0 ~ 360 degree	N/A	Apr. 01, 2014~ Apr. 03, 2014	N/A	Radiation (03CH07-HY)
Antenna Mast	ChainTek	ChainTek 3000	N/A	N/A	N/A	Apr. 01, 2014~ Apr. 03, 2014	N/A	Radiation (03CH07-HY)
EMI Test Receiver	Rohde & Schwarz	ESCS 30	100356	9kHz ~ 2.75GHz	Nov. 15, 2013	Mar. 26, 2014	Nov. 14, 2014	Conduction (CO05-HY)
LISN (for auxiliary equipment)	Rohde & Schwarz	ENV216	100081	9kHz ~ 30MHz	Dec. 12, 2013	Mar. 26, 2014	Dec. 11, 2014	Conduction (CO05-HY)
LISN	Rohde & Schwarz	ENV216	100080	9kHz ~ 30MHz	Dec. 04, 2013	Mar. 26, 2014	Dec. 03, 2014	Conduction (CO05-HY)
AC Power Source	ChainTek	APC-1000W	N/A	N/A	N/A	Mar. 26, 2014	N/A	Conduction (CO05-HY)



5 Uncertainty of Evaluation

Uncertainty of Conducted Emission Measurement (150kHz ~ 30MHz)

Measuring Uncertainty for a Level of Confidence of 95% ($U = 2Uc(y)$)	2.26
---	------

Uncertainty of Radiated Emission Measurement (30 MHz ~ 1000 MHz)

Measuring Uncertainty for a Level of Confidence of 95% ($U = 2Uc(y)$)	4.50
---	------