

# FCC RF Test Report

APPLICANT : Motorola Mobility, LLC  
EQUIPMENT : Mobile Cellular Phone  
BRAND NAME : Motorola Mobility, LLC  
MODEL NAME : 4008  
FCC ID : IHDT56PG4  
STANDARD : FCC Part 15 Subpart C §15.247  
CLASSIFICATION : (DTS) Digital Transmission System

The product was received on Mar. 31, 2014. We, SPORTON INTERNATIONAL INC., would like to declare that the tested sample has been evaluated in accordance with the test procedures and the testing has shown the tested sample to be in compliance with the applicable technical standards.

The test results in this report apply exclusively to the tested model / sample. Without written approval of SPORTON INTERNATIONAL INC., the test report shall not be reproduced except in full.



Reviewed by: Joseph Lin / Supervisor



Approved by: Jones Tsai / Manager



## SPORTON INTERNATIONAL INC.

No. 52, Hwa Ya 1<sup>st</sup> Rd., Hwa Ya Technology Park, Kwei-Shan Hsiang, Tao Yuan Hsien, Taiwan, R.O.C.



# TABLE OF CONTENTS

REVISION HISTORY ..... 3

1 GENERAL DESCRIPTION ..... 4

    1.1 Applicant ..... 4

    1.2 Manufacturer ..... 4

    1.3 Feature of Equipment Under Test ..... 4

    1.4 Product Specification of Equipment Under Test ..... 4

    1.5 Modification of EUT ..... 4

APPENDIX A. ORIGINAL REPORT





# 1 General Description

## 1.1 Applicant

Motorola Mobility, LLC

222 W Merchandise Mart Plaza, Suite 1800, Chicago, IL 60654, United States

## 1.2 Manufacturer

Motorola Mobility, LLC

222 W Merchandise Mart Plaza, Suite 1800, Chicago, IL 60654, United States

## 1.3 Feature of Equipment Under Test

Product Feature	
Equipment	Mobile Cellular Phone
Brand Name	Motorola Mobility, LLC
Model Name	4008
FCC ID	IHDT56PG4
EUT supports Radios application	GSM/EGPRS/WCDMA/HSPA WLAN 11b/g/n HT20 Bluetooth v4.0 EDR/LE
HW Version	P3A
SW Version	4.4.2 KXB20.82 66
EUT Stage	Identical Prototype

Remark: The above EUT's information was declared by manufacturer. Please refer to the specifications or user's manual for more detailed description.

## 1.4 Product Specification of Equipment Under Test

Product Specification subjective to this standard	
Tx/Rx Channel Frequency Range	2412 MHz ~ 2462 MHz
Antenna Type	PIFA Antenna type with gain 1.10 dBi
Type of Modulation	802.11b : DSSS (DBPSK / DQPSK / CCK) 802.11g/n : OFDM (BPSK / QPSK / 16QAM / 64QAM)

## 1.5 Modification of EUT

No modifications are made to the EUT during all test items.



## **Appendix A. Original Report**

Please refer to Sporton report number FR431235C as below.



# FCC/IC RF Test Report

APPLICANT : Motorola Mobility, LLC  
EQUIPMENT : Mobile Cellular Phone  
BRAND NAME : Motorola Mobility, LLC  
MODEL NAME : 4005  
FCC ID : IHDT56PG3  
IC : 109O-T56PG3  
STANDARD : FCC Part 15 Subpart C §15.247  
IC RSS-210 issue 8  
CLASSIFICATION : (DTS) Digital Transmission System

The product was received on Mar. 12, 2014 and testing was completed on Apr. 01, 2014. We, SPORTON INTERNATIONAL INC., would like to declare that the tested sample has been evaluated in accordance with the procedures and shown to be compliant with the applicable technical standards.

The test results in this report apply exclusively to the tested model / sample. Without written approval of SPORTON INTERNATIONAL INC., the test report shall not be reproduced except in full.

Reviewed by: Joseph Lin / Supervisor

Approved by: Jones Tsai / Manager



## SPORTON INTERNATIONAL INC.

No. 52, Hwa Ya 1<sup>st</sup> Rd., Hwa Ya Technology Park, Kwei-Shan Hsiang, Tao Yuan Hsien, Taiwan, R.O.C.

SPORTON INTERNATIONAL INC.

TEL : 886-3-327-3456

FAX : 886-3-328-4978

FCC ID : IHDT56PG3

IC : 109O-T56PG3

Page Number : 1 of 54

Report Issued Date : Apr. 14, 2014

Report Version : Rev. 01



# TABLE OF CONTENTS

**REVISION HISTORY ..... 3**

**SUMMARY OF TEST RESULT ..... 4**

**1 GENERAL DESCRIPTION ..... 5**

    1.1 Applicant ..... 5

    1.2 Manufacturer ..... 5

    1.3 Feature of Equipment Under Test ..... 5

    1.4 Product Specification of Equipment Under Test ..... 6

    1.5 Modification of EUT ..... 6

    1.6 Testing Location ..... 6

    1.7 Applied Standards ..... 7

**2 TEST CONFIGURATION OF EQUIPMENT UNDER TEST ..... 8**

    2.1 Carrier Frequency Channel ..... 8

    2.2 Pre-Scanned RF Power ..... 9

    2.3 Test Mode ..... 10

    2.4 Connection Diagram of Test System ..... 11

    2.5 Support Unit used in test configuration and system ..... 12

    2.6 EUT Operation Test Setup ..... 12

    2.7 Measurement Results Explanation Example ..... 12

**3 TEST RESULT ..... 13**

    3.1 6dB and 99% Bandwidth Measurement ..... 13

    3.2 Output Power Measurement ..... 15

    3.3 Power Spectral Density Measurement ..... 18

    3.4 Conducted Band Edges and Spurious Emission Measurement ..... 20

    3.5 Radiated Band Edges and Spurious Emission Measurement ..... 30

    3.6 AC Conducted Emission Measurement ..... 48

    3.7 Antenna Requirements ..... 52

**4 LIST OF MEASURING EQUIPMENT ..... 53**

**5 UNCERTAINTY OF EVALUATION ..... 54**



**SUMMARY OF TEST RESULT**

Report Section	FCC Rule	IC Rule	Description	Limit	Result	Remark
3.1	15.247(a)(2)	RSS-210 A8.2(a)	6dB Bandwidth	$\geq 0.5\text{MHz}$	Pass	-
3.1	-	RSS-Gen 4.6.1	99% Bandwidth	-	Pass	-
3.2	15.247(b)	RSS-210 A8.4	Power Output Measurement	$\leq 30\text{dBm}$	Pass	-
3.3	15.247(e)	RSS-210 A8.2(b)	Power Spectral Density	$\leq 8\text{dBm}/3\text{kHz}$	Pass	-
3.4	15.247(d)	RSS-210 A8.5	Conducted Band Edges	$\leq 20\text{dBc}$	Pass	-
			Conducted Spurious Emission		Pass	-
3.5	15.247(d)	RSS-210 A8.5	Radiated Band Edges and Radiated Spurious Emission	15.209(a) & 15.247(d)	Pass	Under limit 1.24 dB at 2483.530 MHz
3.6	15.207	RSS-Gen 7.2.4	AC Conducted Emission	15.207(a)	Pass	Under limit 16.20 dB at 0.670 MHz
3.7	15.203 & 15.247(b)	RSS-210 A8.4	Antenna Requirement	N/A	Pass	-



# 1 General Description

## 1.1 Applicant

**Motorola Mobility, LLC**

222 W Merchandise Mart Plaza, Suite 1800, Chicago, IL 60654, United States

## 1.2 Manufacturer

**Motorola Mobility, LLC**

222 W Merchandise Mart Plaza, Suite 1800, Chicago, IL 60654, United States

## 1.3 Feature of Equipment Under Test

Product Feature	
Equipment	Mobile Cellular Phone
Brand Name	Motorola Mobility, LLC
Model Name	4005
FCC ID	IHDT56PG3
IC	109O-T56PG3
IMEI Code	359291050000710
EUT supports Radios application	GSM/EGPRS/WCDMA/HSPA/LTE WLAN 11b/g/n HT20 Bluetooth v3.0 + EDR Bluetooth v4.0 - LE
HW Version	P2D
SW Version	4.4.2 KXB20.82 66
EUT Stage	Identical Prototype

**Remark:** The above EUT's information was declared by manufacturer. Please refer to the specifications or user's manual for more detailed description.

### 1.4 Product Specification of Equipment Under Test

Product Specification subjective to this standard	
Tx/Rx Channel Frequency Range	2412 MHz ~ 2462 MHz
Maximum (Peak) Output Power to Antenna	802.11b : 20.66 dBm (0.1164 W) 802.11g : 22.95 dBm (0.1972 W) 802.11n HT20 : 22.36 dBm (0.1722 W)
99% Occupied Bandwidth	802.11b : 13.20MHz 802.11g : 18.90MHz 802.11n HT20 : 19.35MHz
Antenna Type	PIFA Antenna type with gain 1.10 dBi
Type of Modulation	802.11b : DSSS (DBPSK / DQPSK / CCK) 802.11g/n : OFDM (BPSK / QPSK / 16QAM / 64QAM)

### 1.5 Modification of EUT

No modifications are made to the EUT during all test items.

### 1.6 Testing Location

Sporton Lab is accredited to ISO 17025 by Taiwan Accreditation Foundation (TAF code : 1190) and the FCC designation No. TW1022 under the FCC 2.948(e) by Mutual Recognition Agreement (MRA) in FCC Test.

Test Site	SPORTON INTERNATIONAL INC.			
Test Site Location	No. 52, Hwa Ya 1 <sup>st</sup> Rd., Hwa Ya Technology Park, Kwei-Shan Hsiang, Tao Yuan Hsien, Taiwan, R.O.C. TEL: +886-3-3273456 / FAX: +886-3-3284978			
Test Site No.	Sporton Site No.			IC Registration No.
	TH02-HY	CO05-HY	03CH06-HY	4086B-1



## 1.7 Applied Standards

According to the specifications of the manufacturer, the EUT must comply with the requirements of the following standards:

- ♦ FCC Part 15 Subpart C §15.247
- ♦ FCC KDB Publication No. 558074 D01 DTS Meas. Guidance v03r01
- ♦ ANSI C63.4-2003
- ♦ IC RSS-210 Issue 8
- ♦ IC RSS-Gen Issue 3
- ♦ NOTICE 2012-DRS0126

### Remark:

1. All test items were verified and recorded according to the standards and without any deviation during the test.
2. This EUT has also been tested and complied with the requirements of FCC Part 15, Subpart B, recorded in a separate test report.
3. Per the section 2.2.3 of Notice of 2012-DRS0126, "Receivers Excluded from Industry Canada Requirements", only radiocommunication receivers operating in stand-alone mode within the band 30-960 MHz and scanner receivers are subject to Industry Canada requirements.



## 2 Test Configuration of Equipment Under Test

The EUT has been associated with peripherals and configuration operated in a manner tended to maximize its emission characteristics in a typical application. Frequency range investigated: conducted emission (150 kHz to 30 MHz) and radiated emission (9 kHz to the 10th harmonic of the highest fundamental frequency or to 40 GHz, whichever is lower). For radiated measurement, pre-scanned in three orthogonal planes, X, Y, Z. The worst cases (Z plane) were recorded in this report.

The final configuration from all the combinations and the worst-case data rates were investigated by measuring the maximum power across all the data rates and modulation modes under section 2.2.

Based on the worst configuration found above, the RF power setting is set individually to meet FCC compliance limit for the final conducted and radiated tests shown in section 2.3.

### 2.1 Carrier Frequency Channel

Frequency Band	Channel	Freq. (MHz)	Channel	Freq. (MHz)
2400-2483.5 MHz	1	2412	7	2442
	2	2417	8	2447
	3	2422	9	2452
	4	2427	10	2457
	5	2432	11	2462
	6	2437	-	-



## 2.2 Pre-Scanned RF Power

Preliminary tests were performed in different data rate and data rate associated with the highest power were chosen for full test shown in the following tables.

Channel	Frequency	2.4GHz 802.11b RF Power (dBm)			
		DSSS Data Rate			
		1 Mbps	2 Mbps	5.5 Mbps	11 Mbps
CH 01	2412MHz	20.55	20.52	20.54	20.53
CH 06	2437MHz	20.66	20.62	20.65	20.65
CH 11	2462MHz	20.61	20.59	20.60	20.55

Channel	Frequency	2.4GHz 802.11g RF Power (dBm)							
		OFDM Data Rate							
		6 Mbps	9 Mbps	12 Mbps	18 Mbps	24 Mbps	36 Mbps	48 Mbps	54 Mbps
CH 01	2412MHz	22.73	22.68	22.56	22.69	22.71	22.66	22.63	22.72
CH 06	2437MHz	22.95	22.92	22.89	22.87	22.93	22.91	22.94	22.94
CH 11	2462MHz	22.85	22.82	22.81	22.84	22.79	22.74	22.82	22.83

Channel	Frequency	2.4GHz 802.11n HT20 RF Power (dBm)							
		OFDM Data Rate							
		MCS0	MCS1	MCS2	MCS3	MCS4	MCS5	MCS6	MCS7
CH 01	2412MHz	22.28	22.25	22.18	22.26	22.18	22.25	22.20	22.26
CH 06	2437MHz	22.22	22.17	22.15	22.13	22.17	22.21	22.20	22.21
CH 11	2462MHz	22.36	22.33	22.34	22.33	22.29	22.31	22.35	22.31



### 2.3 Test Mode

Final results of test modes, data rates and test channels are shown as following table.

Test Cases				
	Test Items	Mode	Data Rate	Test Channel
Conducted TCs	6dB and 99% BW Power Spectral Density	802.11b	1 Mbps	1/6/11
		802.11g	6 Mbps	1/6/11
		802.11n HT20	MCS0	1/6/11
	Output Power	802.11b	1 Mbps	1/6/11
		802.11g	6 Mbps	1/6/11
		802.11n HT20	MCS0	1/6/11
	Conducted Band Edge	802.11b	1 Mbps	1/11
		802.11g	6 Mbps	1/11
		802.11n HT20	MCS0	1/11
	Conducted Spurious Emission	802.11b	1 Mbps	1/6/11
		802.11g	6 Mbps	1/6/11
		802.11n HT20	MCS0	1/6/11
Radiated TCs	Radiated Band Edge	802.11b	1 Mbps	1/11
		802.11g	6 Mbps	1/11
		802.11n HT20	MCS0	1/11
	Radiated Spurious Emission	802.11b	1 Mbps	1/6/11
		802.11g	6 Mbps	1/6/11
		802.11n HT20	MCS0	1/6/11

Test Cases	
AC Conducted Emission	Mode 1 : GSM850 Idle + Bluetooth Link + WLAN Link + MP3 + Earphone + Battery + Adapter

## 2.4 Connection Diagram of Test System

### <WLAN Tx Mode>

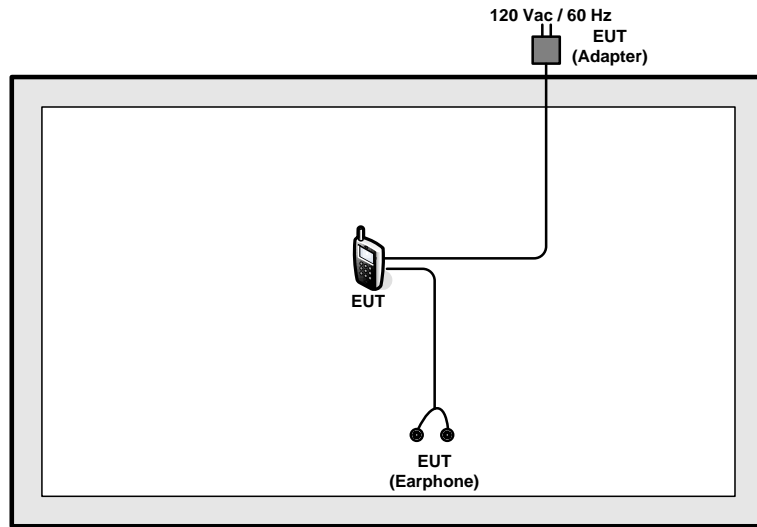

### <AC Conducted Emission Mode>

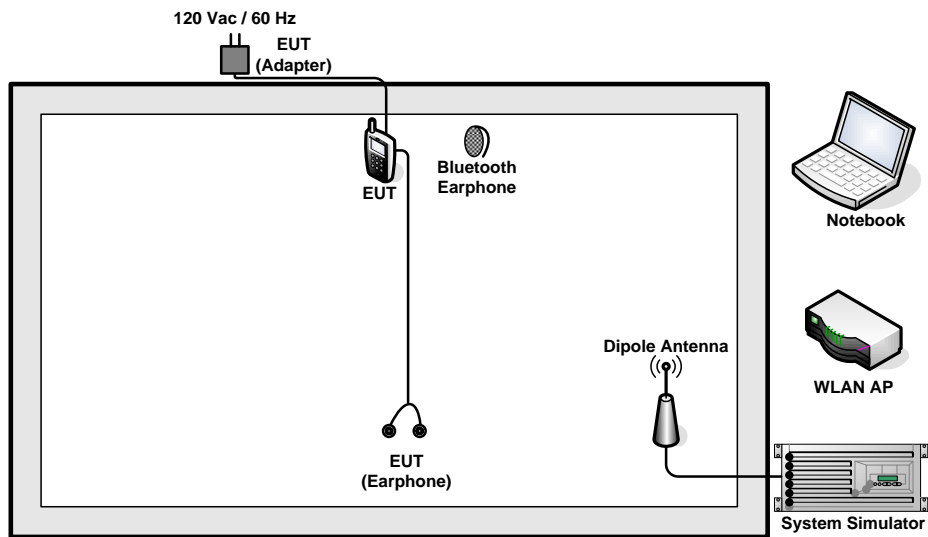

## 2.5 Support Unit used in test configuration and system

Item	Equipment	Trade Name	Model Name	FCC ID	Data Cable	Power Cord
1.	System Simulator	R&S	CMU 200	N/A	N/A	Unshielded, 1.8 m
2.	WLAN AP	D-Link	DIR-628	KA2DIR628A2	N/A	Unshielded, 1.8 m
3.	Notebook	DELL	Latitude E6320	FCC DoC	N/A	AC I/P: Unshielded, 1.2 m DC O/P: Shielded, 1.8 m
4.	Bluetooth Earphone	Sony Ericsson	MW600	PY7DDA-2029	N/A	N/A
5.	SD Card	SanDisk	MicroSD HC	FCC DoC	N/A	N/A

## 2.6 EUT Operation Test Setup

For WLAN function, programmed RF utility, “ADB” installed in the EUT make the EUT provide functions like channel selection and power level for continuous transmitting and receiving signals.

## 2.7 Measurement Results Explanation Example

For all conducted test items:

The offset level is set in the spectrum analyzer to compensate the RF cable loss and attenuator factor between EUT conducted output port and spectrum analyzer. With the offset compensation, the spectrum analyzer reading level is exactly the EUT RF output level.

Example :

The spectrum analyzer offset is derived from RF cable loss and attenuator factor.

$$\text{Offset} = \text{RF cable loss} + \text{attenuator factor}.$$

Following shows an offset computation example with cable loss 4.2 dB and 10dB attenuator.

$$\begin{aligned} \text{Offset(dB)} &= \text{RF cable loss(dB)} + \text{attenuator factor(dB)}. \\ &= 4.2 + 10 = 14.2 \text{ (dB)} \end{aligned}$$

### 3 Test Result

#### 3.1 6dB and 99% Bandwidth Measurement

##### 3.1.1 Limit of 6dB and 99% Bandwidth

The minimum 6 dB bandwidth shall be at least 500 kHz.

##### 3.1.2 Measuring Instruments

The measuring equipment is listed in the section 4 of this test report.

##### 3.1.3 Test Procedures

1. The testing follows FCC KDB Publication No. 558074 DTS D01 Meas. Guidance v03r01.
2. The RF output of EUT was connected to the spectrum analyzer by RF cable and attenuator. The path loss was compensated to the results for each measurement.
3. Set to the maximum power setting and enable the EUT transmit continuously.
4. Make the measurement with the spectrum analyzer's resolution bandwidth (RBW) = 100 kHz. Set the Video bandwidth (VBW) = 300 kHz. In order to make an accurate measurement. The 6 dB bandwidth must be greater than 500 kHz.
5. For 99% Bandwidth Measurement, the spectrum analyzer's resolution bandwidth (RBW) = 1MHz and set the Video bandwidth (VBW) = 3MHz.
6. Measure and record the results in the test report.

##### 3.1.4 Test Setup

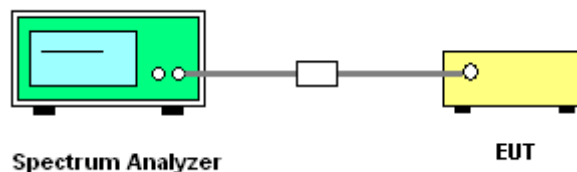



3.1.5 Test Result of 6dB and 99% Occupied Bandwidth

Test Band :	2.4GHz	Temperature :	21~26°C
Test Engineer :	Stuart Lin and Jun Yang	Relative Humidity :	45~54%

Mod.	Data Rate	N <sub>TX</sub>	Channel	Freq. (MHz)	99% Bandwidth (MHz)	6dB Bandwidth (MHz)	6dB Bandwidth Min. Limit (MHz)	Pass/Fail
11b	1Mbps	1	1	2412	13.20	7.50	0.5	Pass
11b	1Mbps	1	6	2437	12.90	7.56	0.5	Pass
11b	1Mbps	1	11	2462	12.90	7.08	0.5	Pass
11g	6Mbps	1	1	2412	18.90	16.30	0.5	Pass
11g	6Mbps	1	6	2437	18.85	16.32	0.5	Pass
11g	6Mbps	1	11	2462	18.70	16.34	0.5	Pass
HT20	MCS0	1	1	2412	19.35	17.28	0.5	Pass
HT20	MCS0	1	6	2437	19.35	17.58	0.5	Pass
HT20	MCS0	1	11	2462	19.30	17.58	0.5	Pass

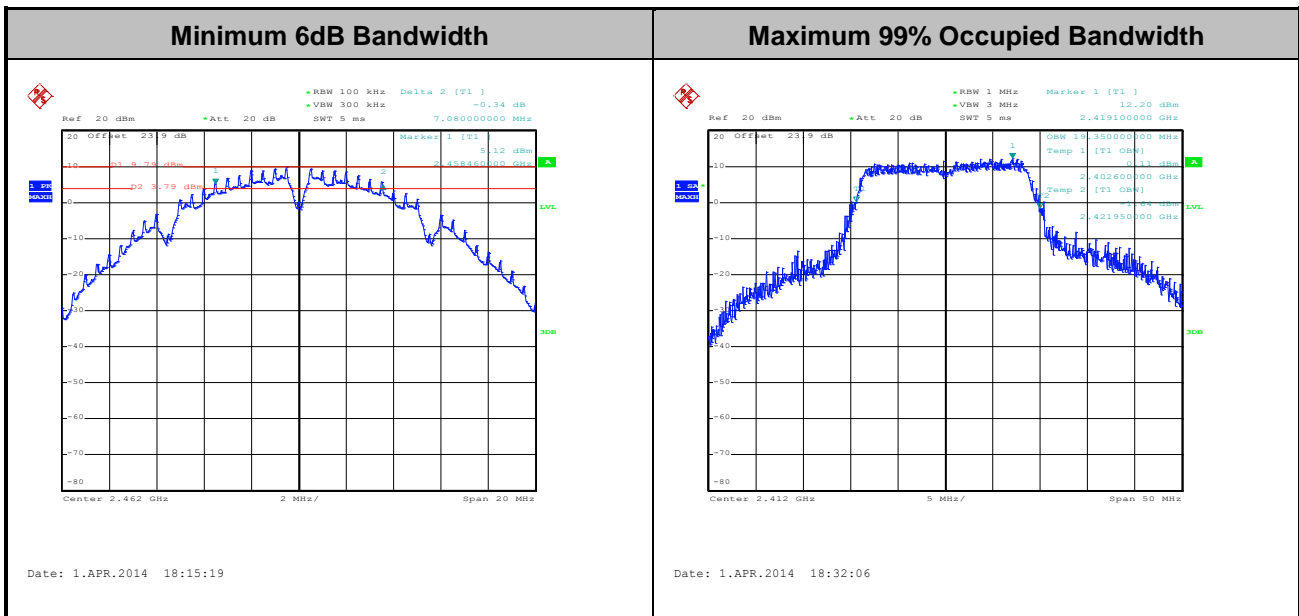

Note: The occupied channel bandwidth is maintained within the band of operation for all of the modulations.

## 3.2 Output Power Measurement

### 3.2.1 Limit of Output Power

For systems using digital modulation in the 2400-2483.5MHz, the limit for peak output power is 30dBm. If transmitting Antenna of directional gain greater than 6dBi are used the peak output power from the intentional radiator shall be reduced below the above stated value by the amount in dB that the directional gain of the Antenna exceeds 6 dBi. In case of point-to-point operation, the limit has to be reduced by 1dB for every 3dB that the directional gain of the Antenna exceeds 6dBi.

### 3.2.2 Measuring Instruments

The measuring equipment is listed in the section 4 of this test report.

### 3.2.3 Test Procedures

1. The testing follows the Measurement Procedure of FCC KDB No. 558074 DTS D01 Meas. Guidance v03r01.
2. The RF output of EUT was connected to the power meter by RF cable and attenuator. The path loss was compensated to the results for each measurement.
3. Set to the maximum power setting and enable the EUT transmit continuously.
4. Measure the conducted output power and record the results in the test report.

### 3.2.4 Test Setup

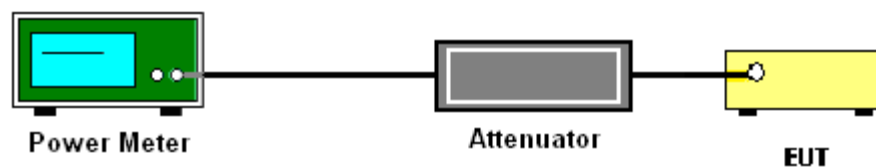



3.2.5 Test Result of Peak Output Power

Test Mode :	2.4GHz	Temperature :	21~26°C
Test Engineer :	Stuart Lin and Jun Yang	Relative Humidity :	45~54%

Mod.	Data Rate	N <sub>TX</sub>	Channel	Freq. (MHz)	RF Output Power (dBm)	Power Limit (dBm)	DG (dBi)	Pass/Fail
11b	1Mbps	1	1	2412	20.55	30	1.10	Pass
11b	1Mbps	1	6	2437	20.66	30	1.10	Pass
11b	1Mbps	1	11	2462	20.61	30	1.10	Pass
11g	6Mbps	1	1	2412	22.73	30	1.10	Pass
11g	6Mbps	1	6	2437	22.95	30	1.10	Pass
11g	6Mbps	1	11	2462	22.85	30	1.10	Pass
HT20	MCS0	1	1	2412	22.28	30	1.10	Pass
HT20	MCS0	1	6	2437	22.22	30	1.10	Pass
HT20	MCS0	1	11	2462	22.36	30	1.10	Pass

Note: Measured power (dBm) has offset with cable loss.



## 3.2.6 Test Result of Average output Power (Reporting Only)

Test Mode :	2.4GHz	Temperature :	21~26°C
Test Engineer :	Stuart Lin and Jun Yang	Relative Humidity :	45~54%

Mod.	Data Rate	N <sub>TX</sub>	Channel	Freq. (MHz)	Duty Factor (dB)	Average Output Power (dBm)	Power Limit (dBm)	DG (dBi)	Pass/Fail
11b	1Mbps	1	1	2412	0.10	17.78	30	1.10	Pass
11b	1Mbps	1	6	2437	0.10	17.83	30	1.10	Pass
11b	1Mbps	1	11	2462	0.10	17.81	30	1.10	Pass
11g	6Mbps	1	1	2412	0.60	15.60	30	1.10	Pass
11g	6Mbps	1	6	2437	0.60	15.98	30	1.10	Pass
11g	6Mbps	1	11	2462	0.60	15.80	30	1.10	Pass
HT20	MCS0	1	1	2412	0.63	14.71	30	1.10	Pass
HT20	MCS0	1	6	2437	0.63	14.55	30	1.10	Pass
HT20	MCS0	1	11	2462	0.63	14.86	30	1.10	Pass

**Note:** Measured power (dBm) has offset with cable loss and duty factor.

### 3.3 Power Spectral Density Measurement

#### 3.3.1 Limit of Power Spectral Density

The peak power spectral density shall not be greater than 8dBm in any 3kHz band at any time interval of continuous transmission.

#### 3.3.2 Measuring Instruments

The measuring equipment is listed in the section 4 of this test report.

#### 3.3.3 Test Procedures

1. The testing follows Measurement Procedure 10.2 Method PKPSD of FCC KDB Publication No. 558074 D01 DTS Meas. Guidance v03r01
2. The RF output of EUT was connected to the spectrum analyzer by RF cable and attenuator. The path loss was compensated to the results for each measurement.
3. Set to the maximum power setting and enable the EUT transmit continuously.
4. Make the measurement with the spectrum analyzer's resolution bandwidth (RBW) = 3 kHz. Video bandwidth VBW = 10 kHz In order to make an accurate measurement, set the span to 1.5 times DTS Channel Bandwidth. (6dB BW)
5. Detector = peak, Sweep time = auto couple, Trace mode = max hold, Allow trace to fully stabilize. Use the peak marker function to determine the maximum power level.
6. Measure and record the results in the test report.

#### 3.3.4 Test Setup

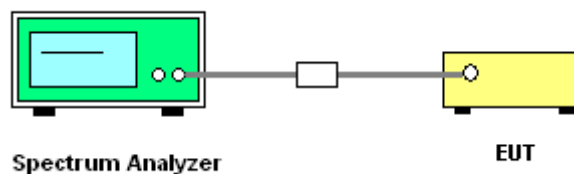



3.3.5 Test Result of Power Spectral Density

Test Mode :	2.4GHz	Temperature :	21~26°C
Test Engineer :	Stuart Lin and Jun Yang	Relative Humidity :	45~54%

Mod.	Data Rate	N <sub>TX</sub>	Channel	Freq. (MHz)	Peak Power Density (dBm/3kHz)	Max. Limits (dBm/3kHz)	DG (dBi)	Pass/Fail
11b	1Mbps	1	1	2412	-3.75	8	1.10	Pass
11b	1Mbps	1	6	2437	-4.14	8	1.10	Pass
11b	1Mbps	1	11	2462	-3.84	8	1.10	Pass
11g	6Mbps	1	1	2412	-10.20	8	1.10	Pass
11g	6Mbps	1	6	2437	-9.38	8	1.10	Pass
11g	6Mbps	1	11	2462	-10.01	8	1.10	Pass
HT20	MCS0	1	1	2412	-10.37	8	1.10	Pass
HT20	MCS0	1	6	2437	-11.17	8	1.10	Pass
HT20	MCS0	1	11	2462	-10.50	8	1.10	Pass

Note: Measured power density (dBm) has offset with cable loss.

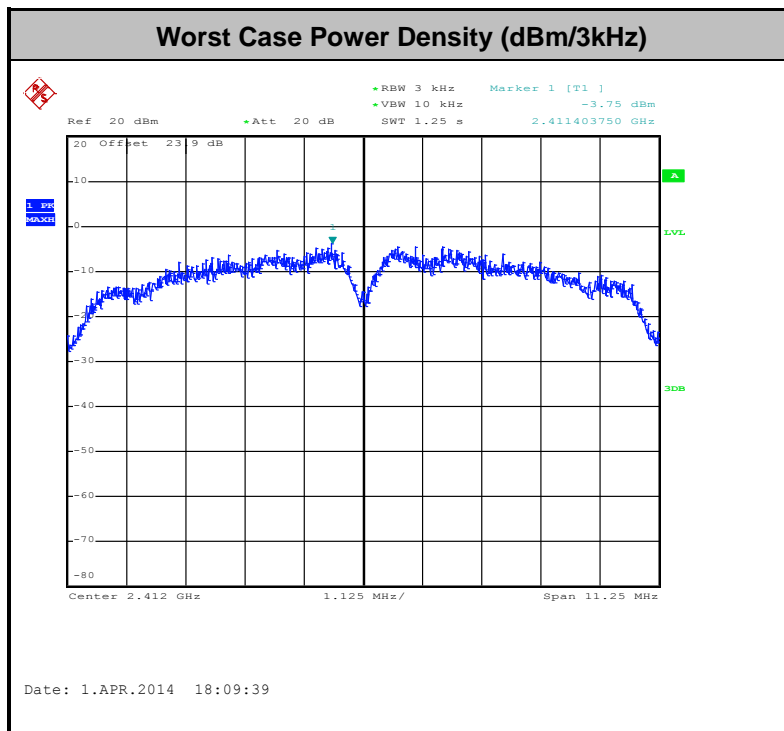

## 3.4 Conducted Band Edges and Spurious Emission Measurement

### 3.4.1 Limit of Conducted Band Edges and Spurious Emission Measurement

In any 100 kHz bandwidth outside of the authorized frequency band, the emissions which fall in the non-restricted bands shall be attenuated at least 20 dB / 30dB relative to the maximum PSD level in 100 kHz by RF conducted measurement and radiated emissions which fall in the restricted bands, as defined in Section 15.205(a), must also comply with the radiated emission limits specified in Section 15.209(a).

### 3.4.2 Measuring Instruments

The measuring equipment is listed in the section 4 of this test report.

### 3.4.3 Test Procedures

1. The testing follows FCC KDB Publication No. 558074 D01 DTS Meas. Guidance v03r01.
2. The RF output of EUT was connected to the spectrum analyzer by RF cable and attenuator. The path loss was compensated to the results for each measurement.
3. Set to the maximum power setting and enable the EUT transmit continuously.
4. Set RBW = 100 kHz, VBW=300 kHz, Peak Detector. Unwanted Emissions measured in any 100 kHz bandwidth outside of the authorized frequency band shall be attenuated by at least 20 dB relative to the maximum in-band peak PSD level in 100 kHz when maximum peak conducted output power procedure is used. If the transmitter complies with the conducted power limits based on the use of RMS averaging over a time interval, the attenuation required under this paragraph shall be 30 dB instead of 20 dB per 15.247(d).
5. Measure and record the results in the test report.
6. The RF fundamental frequency should be excluded against the limit line in the operating frequency band.

### 3.4.4 Test Setup

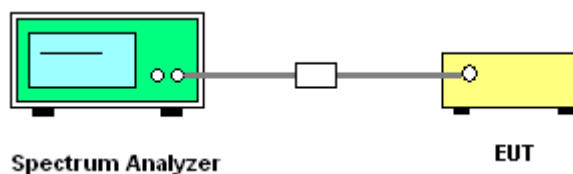



3.4.5 Test Result of Conducted Band Edges and Spurious Emission

Test Mode :	802.11b	Temperature :	21~26°C
Test Band :	2.4GHz Low	Relative Humidity :	45~54%
Test Channel :	01	Test Engineer :	Stuart Lin and Jun Yang

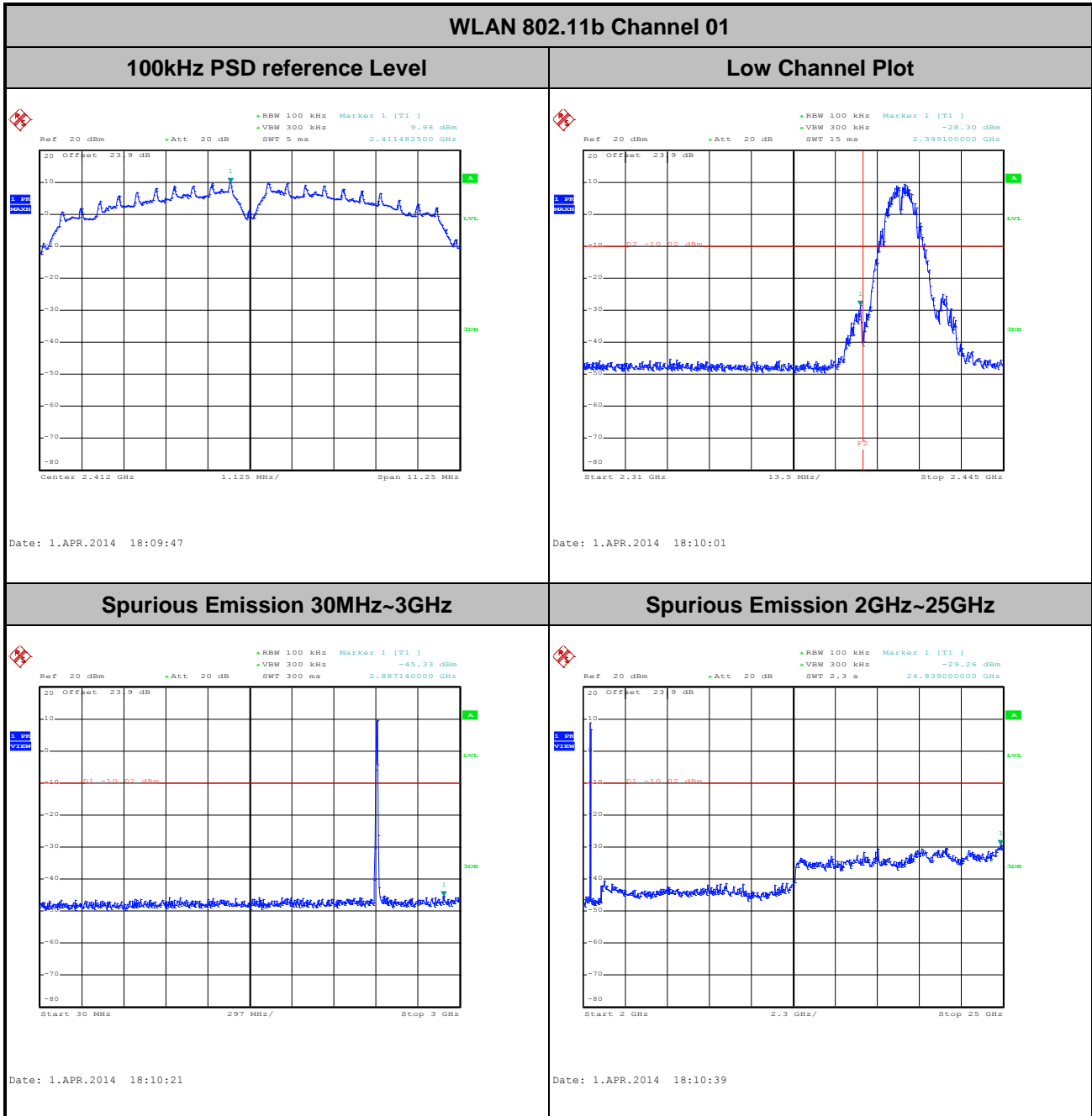



Test Mode :	802.11b	Temperature :	21~26°C
Test Band :	2.4GHz Mid.	Relative Humidity :	45~54%
Test Channel :	06	Test Engineer :	Stuart Lin and Jun Yang

WLAN 802.11b Channel 06

100kHz PSD reference Level

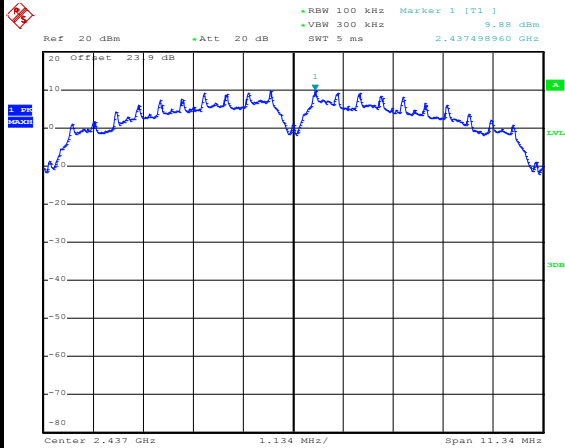

Date: 1.APR.2014 18:13:15

Spurious Emission 30MHz~3GHz

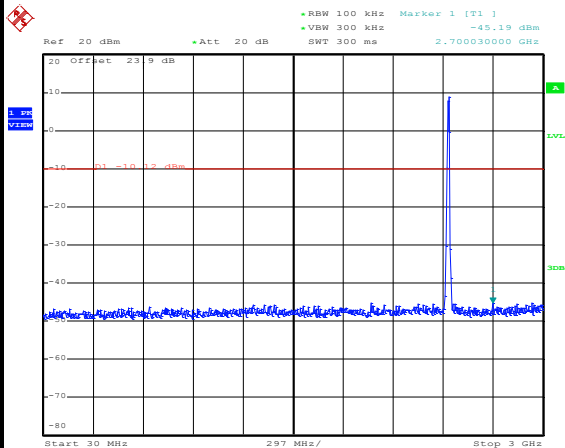

Date: 1.APR.2014 18:13:35

Spurious Emission 2GHz~25GHz

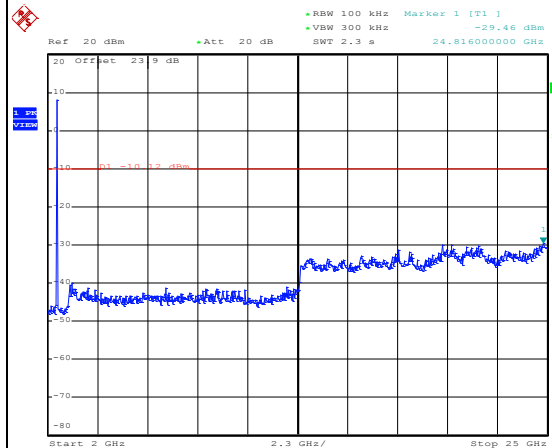

Date: 1.APR.2014 18:13:54



Test Mode :	802.11b	Temperature :	21~26°C
Test Band :	2.4GHz High	Relative Humidity :	45~54%
Test Channel :	11	Test Engineer :	Stuart Lin and Jun Yang

WLAN 802.11b Channel 11

100kHz PSD reference Level

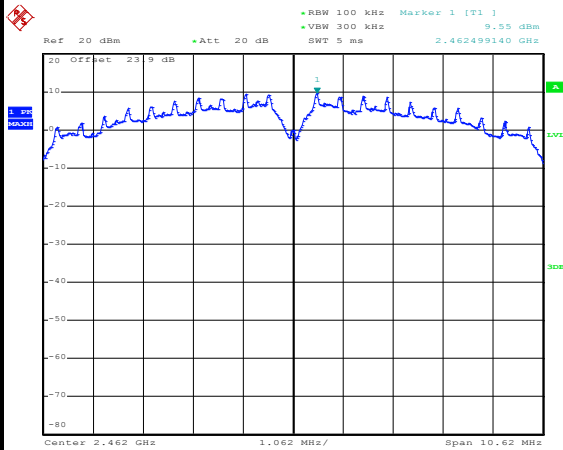

Date: 1.APR.2014 18:15:48

High Channel Plot

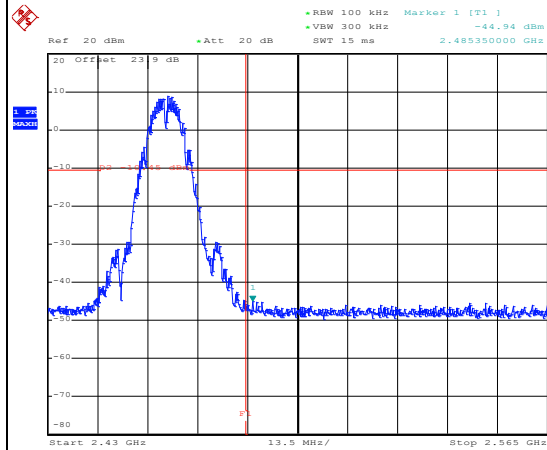

Date: 1.APR.2014 18:16:02

Spurious Emission 30MHz~3GHz

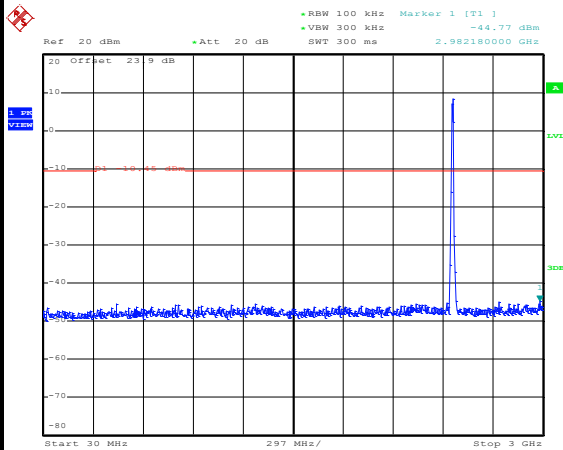

Date: 1.APR.2014 18:16:21

Spurious Emission 2GHz~25GHz

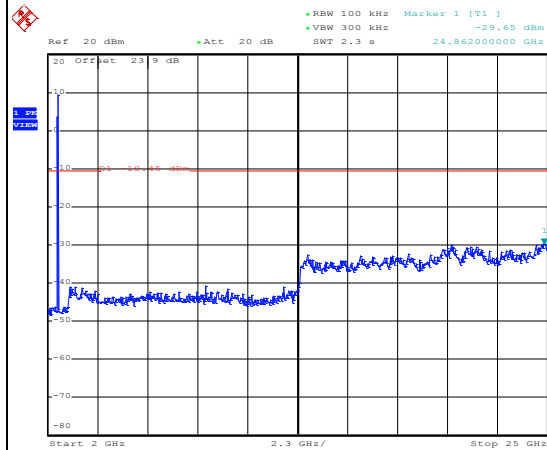

Date: 1.APR.2014 18:16:40



Test Mode :	802.11g	Temperature :	21~26°C
Test Band :	2.4GHz Low	Relative Humidity :	45~54%
Test Channel :	01	Test Engineer :	Stuart Lin and Jun Yang

WLAN 802.11g Channel 01

100kHz PSD reference Level

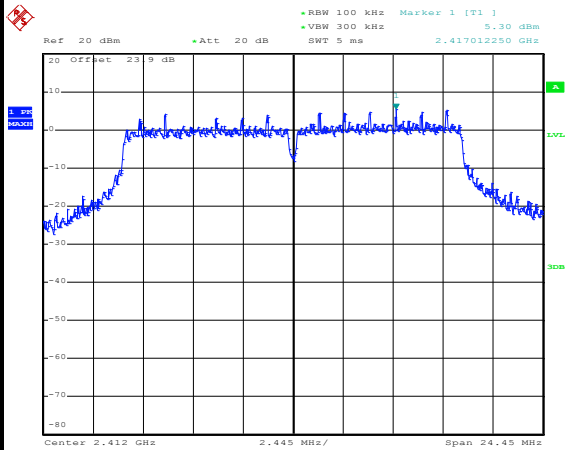

Date: 1.APR.2014 18:27:38

Low Channel Plot

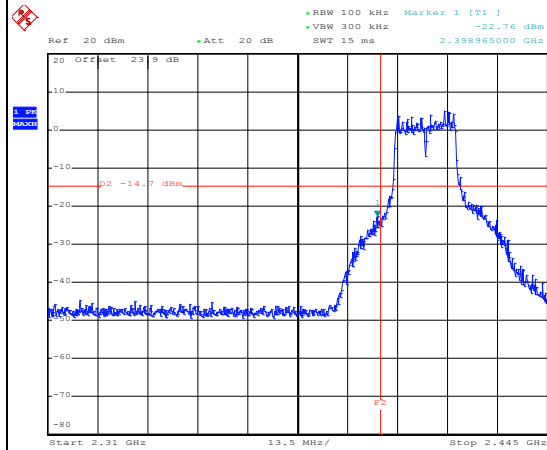

Date: 1.APR.2014 18:27:52

Spurious Emission 30MHz~3GHz

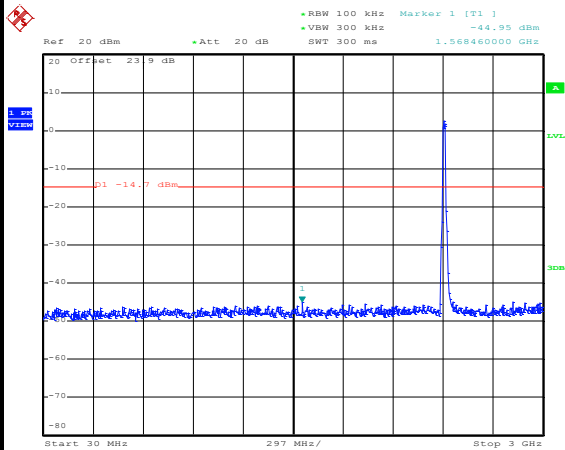

Date: 1.APR.2014 18:28:11

Spurious Emission 2GHz~25GHz

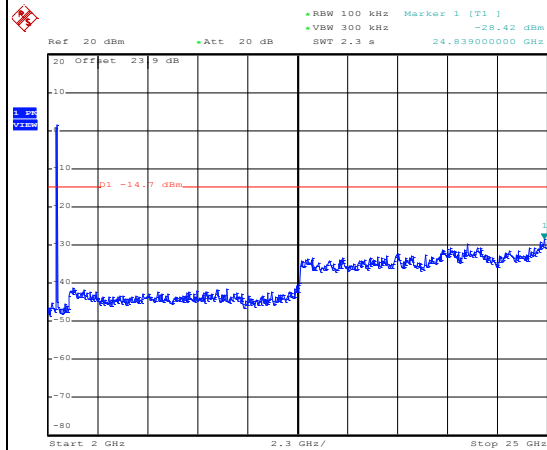

Date: 1.APR.2014 18:28:30



Test Mode :	802.11g	Temperature :	21~26°C
Test Band :	2.4GHz Mid.	Relative Humidity :	45~54%
Test Channel :	06	Test Engineer :	Stuart Lin and Jun Yang

WLAN 802.11g Channel 06

100kHz PSD reference Level

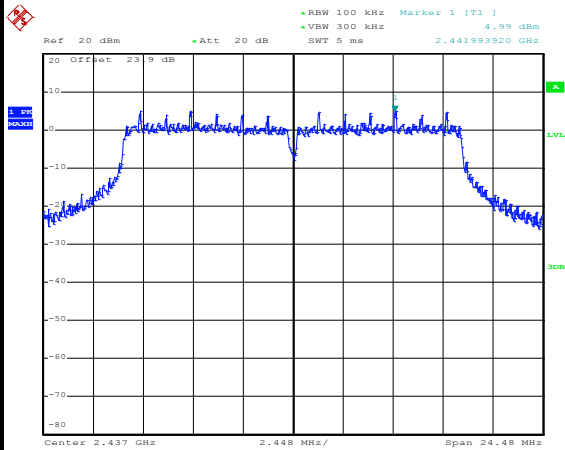

Date: 1.APR.2014 18:25:01

Spurious Emission 30MHz~3GHz

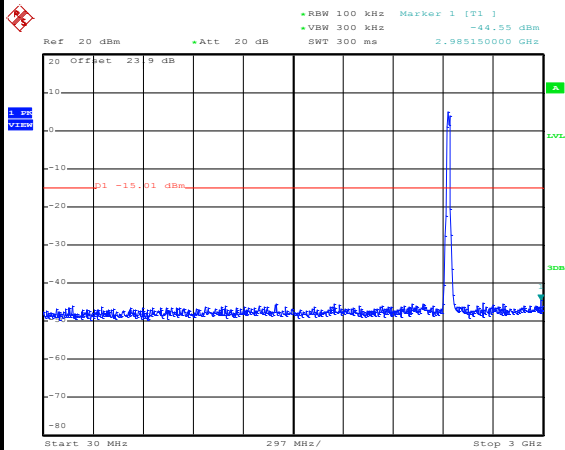

Date: 1.APR.2014 18:25:21

Spurious Emission 2GHz~25GHz

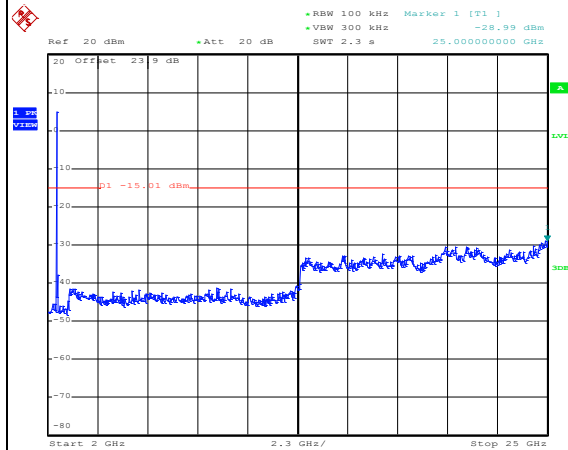

Date: 1.APR.2014 18:25:40



Test Mode :	802.11g	Temperature :	21~26°C
Test Band :	2.4GHz High	Relative Humidity :	45~54%
Test Channel :	11	Test Engineer :	Stuart Lin and Jun Yang

WLAN 802.11g Channel 11

100kHz PSD reference Level

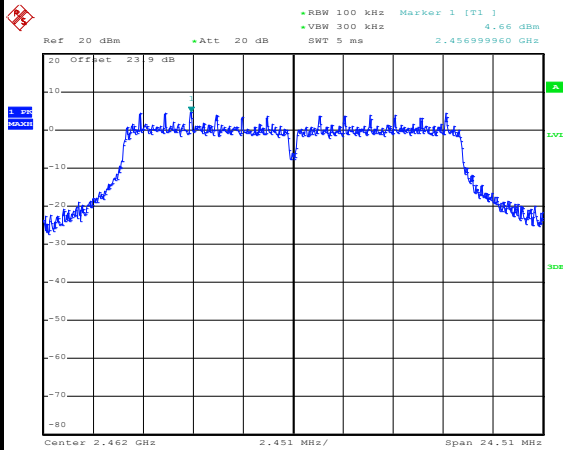

Date: 1.APR.2014 18:19:40

High Channel Plot

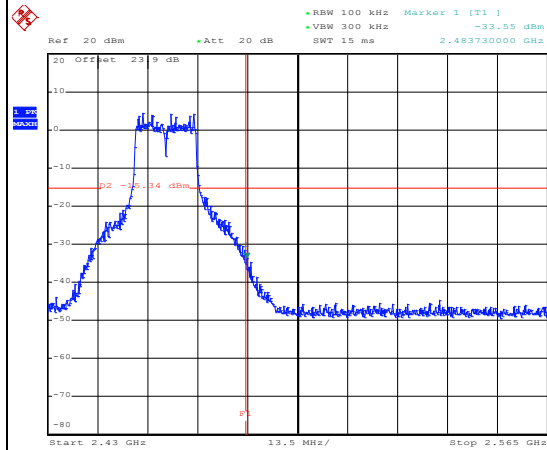

Date: 1.APR.2014 18:22:16

Spurious Emission 30MHz~3GHz

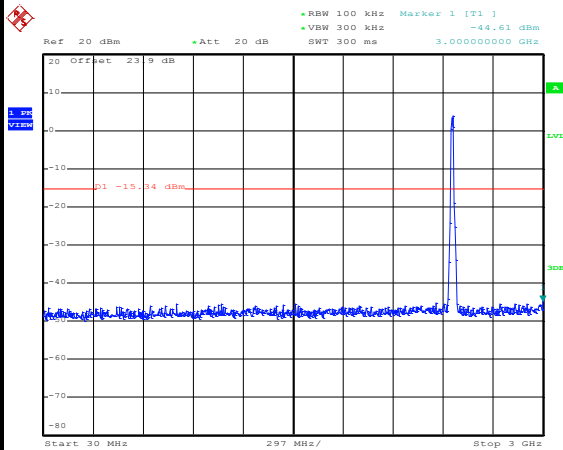

Date: 1.APR.2014 18:21:32

Spurious Emission 2GHz~25GHz

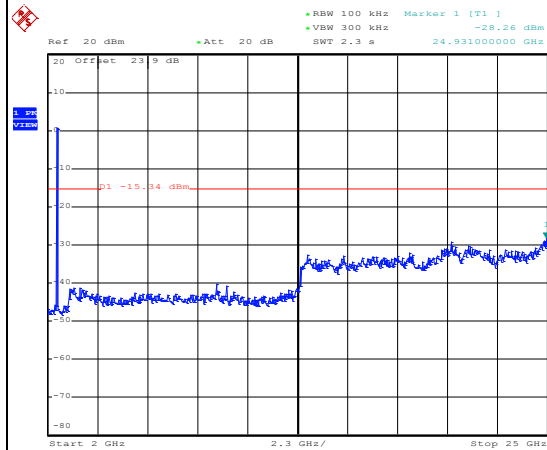

Date: 1.APR.2014 18:21:51



Test Mode :	802.11n HT20	Temperature :	21~26°C
Test Band :	2.4GHz Low	Relative Humidity :	45~54%
Test Channel :	01	Test Engineer :	Stuart Lin and Jun Yang

WLAN 802.11n HT20 Channel 01

100kHz PSD reference Level

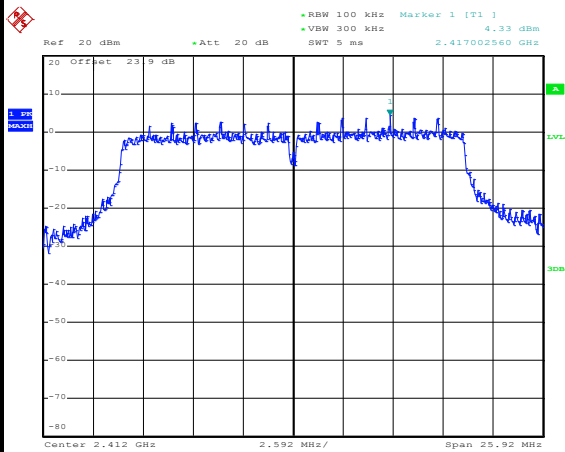

Date: 1.APR.2014 18:31:03

Low Channel Plot

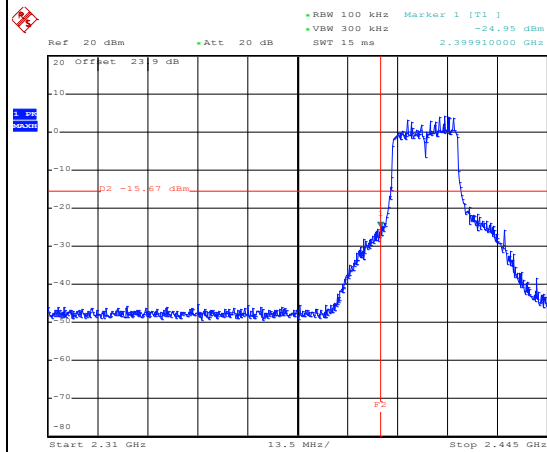

Date: 1.APR.2014 18:31:17

Spurious Emission 30MHz~3GHz

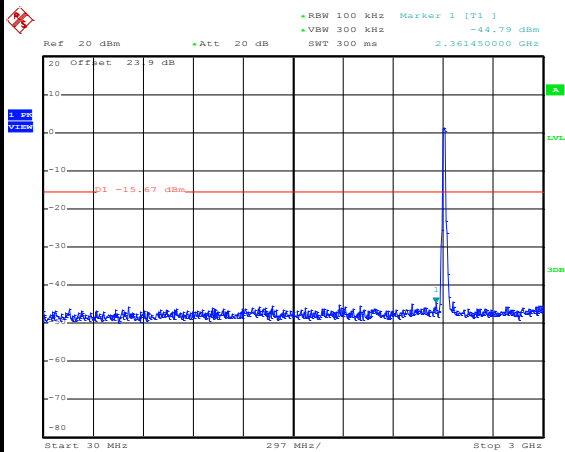

Date: 1.APR.2014 18:31:37

Spurious Emission 2GHz~25GHz

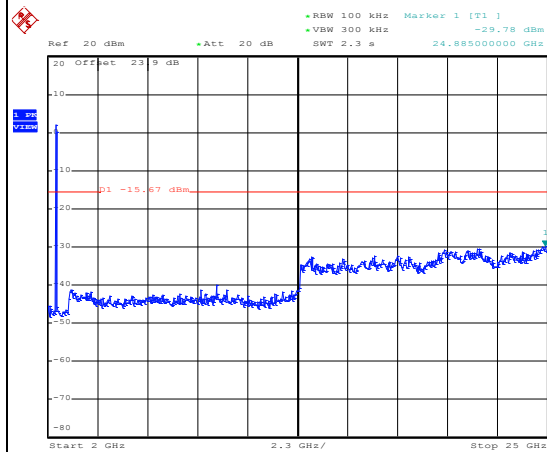

Date: 1.APR.2014 18:31:55



Test Mode :	802.11n HT20	Temperature :	21~26°C
Test Band :	2.4GHz Mid.	Relative Humidity :	45~54%
Test Channel :	06	Test Engineer :	Stuart Lin and Jun Yang

WLAN 802.11n HT20 Channel 06

100kHz PSD reference Level

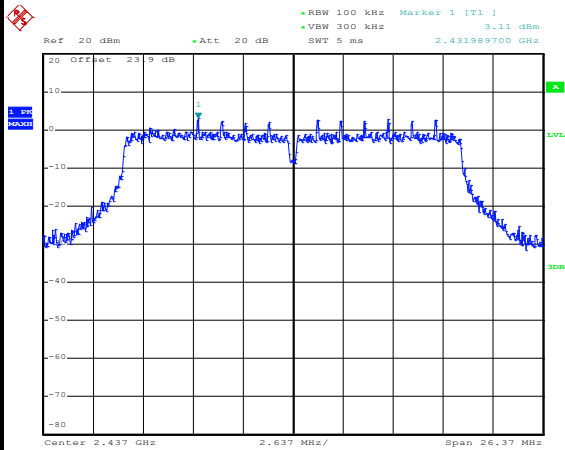

Date: 1.APR.2014 18:35:02

Spurious Emission 30MHz~3GHz

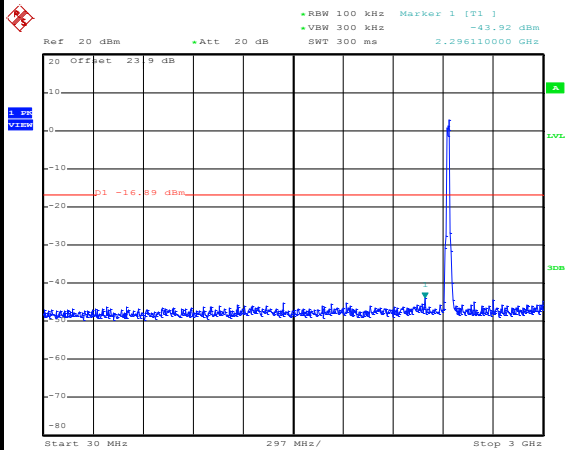

Date: 1.APR.2014 18:35:22

Spurious Emission 2GHz~25GHz

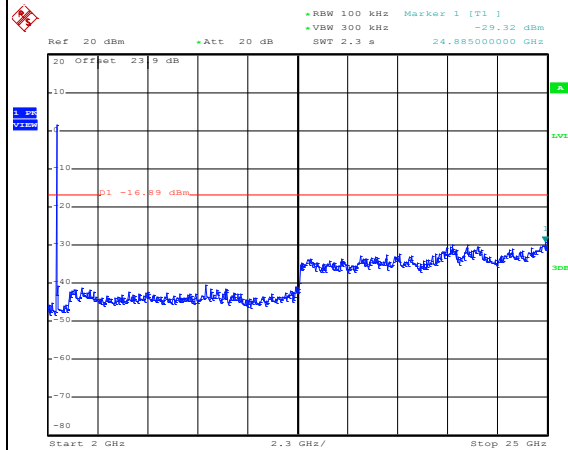

Date: 1.APR.2014 18:35:40



Test Mode :	802.11n HT20	Temperature :	21~26°C
Test Band :	2.4GHz High	Relative Humidity :	45~54%
Test Channel :	11	Test Engineer :	Stuart Lin and Jun Yang

WLAN 802.11n HT20 Channel 11

100kHz PSD reference Level

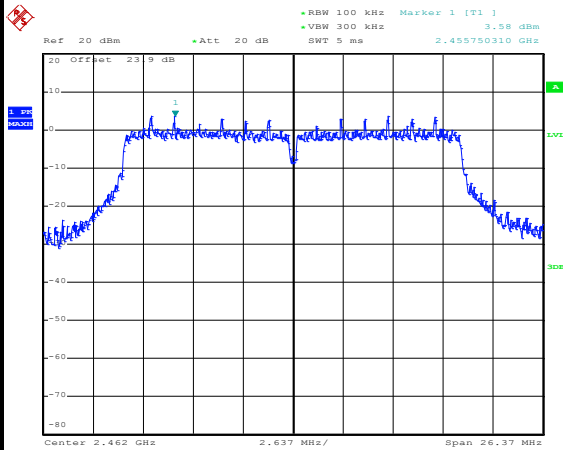

Date: 1.APR.2014 18:38:38

High Channel Plot

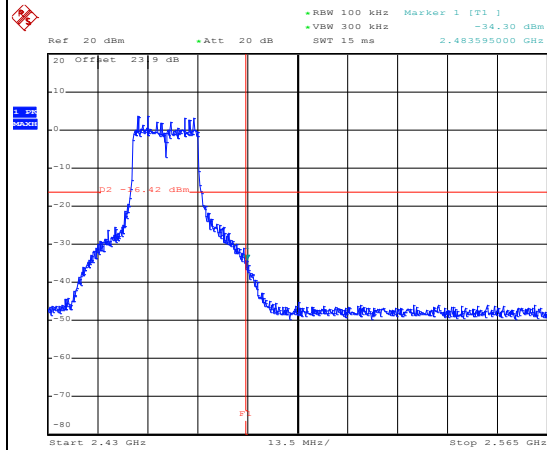

Date: 1.APR.2014 18:38:51

Spurious Emission 30MHz~3GHz

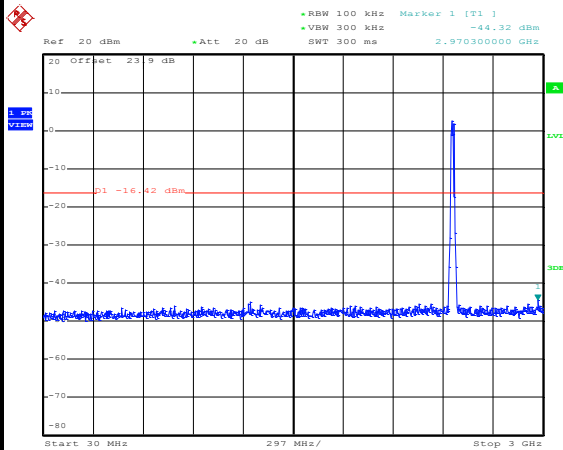

Date: 1.APR.2014 18:41:08

Spurious Emission 2GHz~25GHz

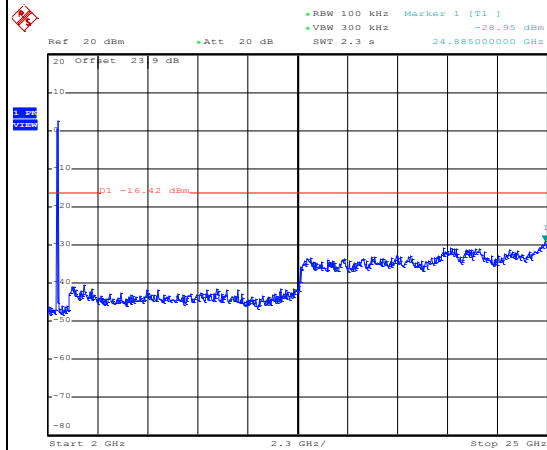

Date: 1.APR.2014 18:40:25



### 3.5 Radiated Band Edges and Spurious Emission Measurement

#### 3.5.1 Limit of Radiated band edge and Spurious Emission Measurement

In any 100 kHz bandwidth outside the intentional radiator frequency band, all harmonics/spurious must be at least 20 dB below the highest emission level within the authorized band. If the output power of this device was measured by spectrum analyzer, the attenuation under this paragraph shall be 30 dB instead of 20 dB. In addition, radiated emissions which fall in the restricted bands must also comply with the FCC section 15.209 limits as below.

Frequency (MHz)	Field Strength (microvolts/meter)	Measurement Distance (meters)
0.009 – 0.490	2400/F(kHz)	300
0.490 – 1.705	24000/F(kHz)	30
1.705 – 30.0	30	30
30 – 88	100	3
88 – 216	150	3
216 - 960	200	3
Above 960	500	3

#### 3.5.2 Measuring Instruments

The measuring equipment is listed in the section 4 of this test report.



3.5.3 Test Procedures

1. The testing follows FCC KDB Publication No. 558074 D01 DTS Meas. Guidance v03r01.
2. The EUT was arranged to its worst case and then tune the antenna tower (from 1 m to 4 m) and turntable (from 0 degree to 360 degrees) to find the maximum reading. A pre-amp and a high pass filter are used for the test in order to get better signal level.
3. The EUT was placed on a turntable with 0.8 meter above ground.
4. The EUT was set 3 meters from the interference receiving antenna, which was mounted on the top of a variable height antenna tower.
5. Corrected Reading: Antenna Factor + Cable Loss + Read Level - Preamp Factor = Level
6. For measurement below 1GHz, If the emission level of the EUT measured by the peak detector is 3 dB lower than the applicable limit, the peak emission level will be reported. Otherwise, the emission measurement will be repeated using the quasi-peak detector and reported.
7. Use the following spectrum analyzer settings:
  - (1) Span shall wide enough to fully capture the emission being measured;
  - (2) Set RBW=100 kHz for f < 1 GHz; VBW ≥ RBW; Sweep = auto; Detector function = peak; Trace = max hold;
  - (3) Set RBW = 1 MHz, VBW= 3MHz for f ≥ 1 GHz for peak measurement.  
For average measurement:
    - VBW = 10 Hz, when duty cycle is no less than 98 percent.
    - VBW ≥ 1/T, when duty cycle is less than 98 percent where T is the minimum transmission duration over which the transmitter is on and is transmitting at its maximum power control level for the tested mode of operation.

Band	Duty Cycle(%)	T(μs)	1/T(kHz)	VBW Setting
802.11b	97.63	8240.00	0.12	300Hz
802.11g	87.18	1360.00	0.74	1kHz
2.4GHz 802.11n HT20	86.49	1280.00	0.78	1kHz

### 3.5.4 Test Setup

For radiated emissions below 30MHz

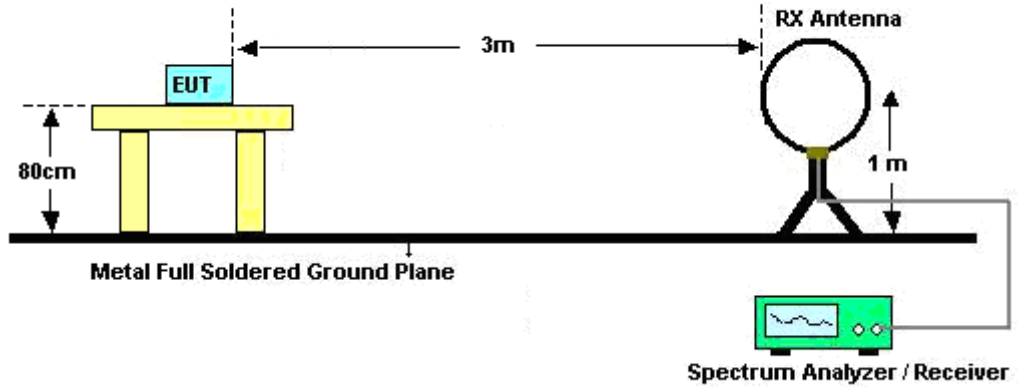

For radiated emissions from 30MHz to 1GHz

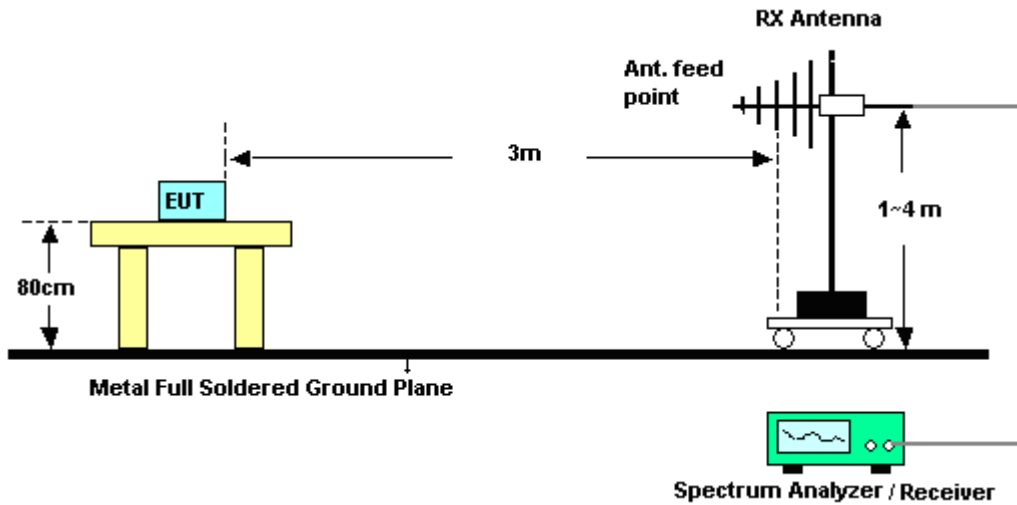

For radiated emissions above 1GHz

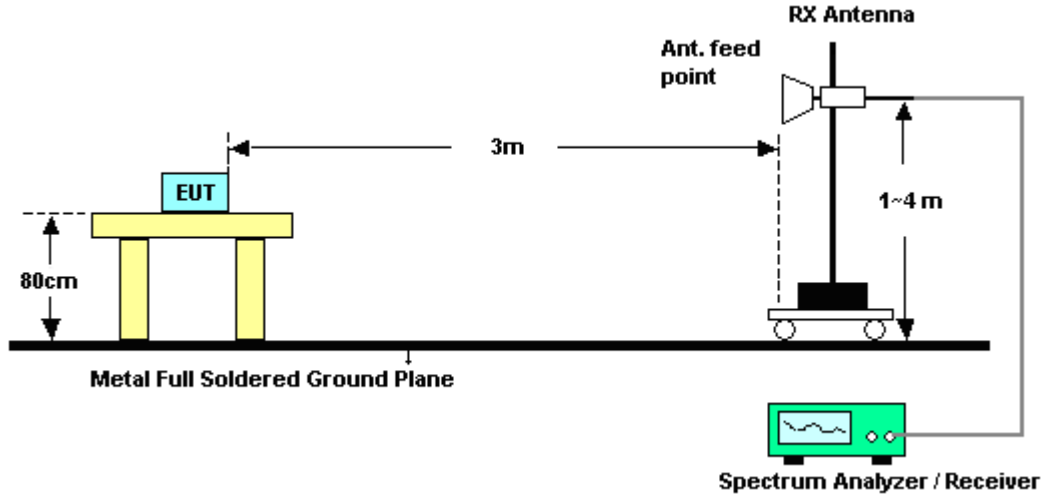

### 3.5.5 Test Results of Radiated Spurious Emissions (9kHz ~ 30MHz)

The low frequency, which started from 9 kHz to 30MHz, was pre-scanned and the result which was 20dB lower than the limit line per 15.31(o) was not reported.



3.5.6 Test Result of Radiated Spurious at Band Edges

Test Mode :	802.11b	Temperature :	24~25°C
Test Band :	Low	Relative Humidity :	46~47%
Test Channel :	01	Test Engineer :	Gavin Wu

ANTENNA POLARITY : HORIZONTAL										
Frequency ( MHz )	Level ( dBμV/m )	Over Limit ( dB )	Limit Line ( dBμV/m )	Read Level ( dBμV )	Antenna Factor ( dB )	Cable Loss ( dB )	Preamp Factor ( dB )	Ant Pos ( cm )	Table Pos ( deg )	Remark
2388.48	49.04	-24.96	74	45	31.92	6.45	34.33	200	61	Peak
2387.76	37.86	-16.14	54	33.82	31.92	6.45	34.33	200	61	Average

ANTENNA POLARITY : VERTICAL										
Frequency ( MHz )	Level ( dBμV/m )	Over Limit ( dB )	Limit Line ( dBμV/m )	Read Level ( dBμV )	Antenna Factor ( dB )	Cable Loss ( dB )	Preamp Factor ( dB )	Ant Pos ( cm )	Table Pos ( deg )	Remark
2384.43	49.03	-24.97	74	45.01	31.9	6.45	34.33	200	84	Peak
2387.85	37.6	-16.4	54	33.56	31.92	6.45	34.33	200	84	Average

Test Mode :	802.11b	Temperature :	24~25°C
Test Band :	High	Relative Humidity :	46~47%
Test Channel :	11	Test Engineer :	Gavin Wu

ANTENNA POLARITY : HORIZONTAL										
Frequency ( MHz )	Level ( dBμV/m )	Over Limit ( dB )	Limit Line ( dBμV/m )	Read Level ( dBμV )	Antenna Factor ( dB )	Cable Loss ( dB )	Preamp Factor ( dB )	Ant Pos ( cm )	Table Pos ( deg )	Remark
2483.68	51.18	-22.82	74	46.9	31.99	6.59	34.3	194	65	Peak
2483.68	39.04	-14.96	54	34.76	31.99	6.59	34.3	194	65	Average

ANTENNA POLARITY : VERTICAL										
Frequency ( MHz )	Level ( dBμV/m )	Over Limit ( dB )	Limit Line ( dBμV/m )	Read Level ( dBμV )	Antenna Factor ( dB )	Cable Loss ( dB )	Preamp Factor ( dB )	Ant Pos ( cm )	Table Pos ( deg )	Remark
2483.59	50.97	-23.03	74	46.69	31.99	6.59	34.3	193	81	Peak
2483.5	38.6	-15.4	54	34.32	31.99	6.59	34.3	193	81	Average



Test Mode :	802.11g	Temperature :	24~25°C
Test Band :	Low	Relative Humidity :	46~47%
Test Channel :	01	Test Engineer :	Gavin Wu

ANTENNA POLARITY : HORIZONTAL										
Frequency ( MHz )	Level ( dBμV/m )	Over Limit ( dB )	Limit Line ( dBμV/m )	Read Level ( dBμV )	Antenna Factor ( dB )	Cable Loss ( dB )	Preamp Factor ( dB )	Ant Pos ( cm )	Table Pos ( deg )	Remark
2389.29	69.9	-4.1	74	65.86	31.92	6.45	34.33	104	134	Peak
2390	46.18	-7.82	54	42.14	31.92	6.45	34.33	104	134	Average

ANTENNA POLARITY : VERTICAL										
Frequency ( MHz )	Level ( dBμV/m )	Over Limit ( dB )	Limit Line ( dBμV/m )	Read Level ( dBμV )	Antenna Factor ( dB )	Cable Loss ( dB )	Preamp Factor ( dB )	Ant Pos ( cm )	Table Pos ( deg )	Remark
2390	70.76	-3.24	74	66.72	31.92	6.45	34.33	200	80	Peak
2390	46.75	-7.25	54	42.71	31.92	6.45	34.33	200	80	Average

Test Mode :	802.11g	Temperature :	24~25°C
Test Band :	High	Relative Humidity :	46~47%
Test Channel :	11	Test Engineer :	Gavin Wu

ANTENNA POLARITY : HORIZONTAL										
Frequency ( MHz )	Level ( dBμV/m )	Over Limit ( dB )	Limit Line ( dBμV/m )	Read Level ( dBμV )	Antenna Factor ( dB )	Cable Loss ( dB )	Preamp Factor ( dB )	Ant Pos ( cm )	Table Pos ( deg )	Remark
2483.74	72.31	-1.69	74	68.03	31.99	6.59	34.3	106	144	Peak
2483.5	47.51	-6.49	54	43.23	31.99	6.59	34.3	106	144	Average

ANTENNA POLARITY : VERTICAL										
Frequency ( MHz )	Level ( dBμV/m )	Over Limit ( dB )	Limit Line ( dBμV/m )	Read Level ( dBμV )	Antenna Factor ( dB )	Cable Loss ( dB )	Preamp Factor ( dB )	Ant Pos ( cm )	Table Pos ( deg )	Remark
2483.5	71.43	-2.57	74	67.15	31.99	6.59	34.3	193	87	Peak
2483.5	46.45	-7.55	54	42.17	31.99	6.59	34.3	193	87	Average



Test Mode :	802.11n HT20	Temperature :	24~25°C
Test Band :	Low	Relative Humidity :	46~47%
Test Channel :	01	Test Engineer :	Gavin Wu

ANTENNA POLARITY : HORIZONTAL										
Frequency ( MHz )	Level ( dBμV/m )	Over Limit ( dB )	Limit Line ( dBμV/m )	Read Level ( dBμV )	Antenna Factor ( dB )	Cable Loss ( dB )	Preamp Factor ( dB )	Ant Pos ( cm )	Table Pos ( deg )	Remark
2390	70.73	-3.27	74	66.69	31.92	6.45	34.33	196	62	Peak
2390	47.8	-6.2	54	43.76	31.92	6.45	34.33	196	62	Average

ANTENNA POLARITY : VERTICAL										
Frequency ( MHz )	Level ( dBμV/m )	Over Limit ( dB )	Limit Line ( dBμV/m )	Read Level ( dBμV )	Antenna Factor ( dB )	Cable Loss ( dB )	Preamp Factor ( dB )	Ant Pos ( cm )	Table Pos ( deg )	Remark
2389.56	70.64	-3.36	74	66.6	31.92	6.45	34.33	200	87	Peak
2390	47.19	-6.81	54	43.15	31.92	6.45	34.33	200	87	Average

Test Mode :	802.11n HT20	Temperature :	24~25°C
Test Band :	High	Relative Humidity :	46~47%
Test Channel :	11	Test Engineer :	Gavin Wu

ANTENNA POLARITY : HORIZONTAL										
Frequency ( MHz )	Level ( dBμV/m )	Over Limit ( dB )	Limit Line ( dBμV/m )	Read Level ( dBμV )	Antenna Factor ( dB )	Cable Loss ( dB )	Preamp Factor ( dB )	Ant Pos ( cm )	Table Pos ( deg )	Remark
2483.53	72.76	-1.24	74	68.48	31.99	6.59	34.3	195	67	Peak
2483.53	47.72	-6.28	54	43.44	31.99	6.59	34.3	195	67	Average

ANTENNA POLARITY : VERTICAL										
Frequency ( MHz )	Level ( dBμV/m )	Over Limit ( dB )	Limit Line ( dBμV/m )	Read Level ( dBμV )	Antenna Factor ( dB )	Cable Loss ( dB )	Preamp Factor ( dB )	Ant Pos ( cm )	Table Pos ( deg )	Remark
2483.56	72.3	-1.7	74	68.02	31.99	6.59	34.3	194	91	Peak
2483.53	47.39	-6.61	54	43.11	31.99	6.59	34.3	194	91	Average



3.5.7 Test Result of Radiated Spurious Emission (30MHz ~ 10<sup>th</sup> Harmonic)

Note: Pre-scanned all test modes and only choose the worst case mode recorded in the test report for radiated spurious emission below 1GHz.

<b>Test Mode :</b>	802.11b	<b>Temperature :</b>	24~25°C
<b>Test Channel :</b>	01	<b>Relative Humidity :</b>	46~47%
<b>Test Engineer :</b>	Gavin Wu	<b>Polarization :</b>	Horizontal
<b>Remark :</b>	1. 2413 MHz is fundamental signal which can be ignored. 2. Average measurement was not performed if peak level went lower than the average limit.		

Frequency ( MHz )	Level ( dBμV/m )	Over Limit ( dB )	Limit Line ( dBμV/m )	Read Level ( dBμV )	Antenna Factor ( dB )	Cable Loss ( dB )	Preamp Factor ( dB )	Ant Pos ( cm )	Table Pos ( deg )	Remark
2413	102.95	-	-	98.86	31.93	6.49	34.33	200	61	Average
2413	107.39	-	-	103.3	31.93	6.49	34.33	200	61	Peak
4824	48.44	-25.56	74	59.46	34.4	10.17	55.59	100	0	Peak

<b>Test Mode :</b>	802.11b	<b>Temperature :</b>	24~25°C
<b>Test Channel :</b>	01	<b>Relative Humidity :</b>	46~47%
<b>Test Engineer :</b>	Gavin Wu	<b>Polarization :</b>	Vertical
<b>Remark :</b>	1. 2413 MHz is fundamental signal which can be ignored. 2. Average measurement was not performed if peak level went lower than the average limit.		

Frequency ( MHz )	Level ( dBμV/m )	Over Limit ( dB )	Limit Line ( dBμV/m )	Read Level ( dBμV )	Antenna Factor ( dB )	Cable Loss ( dB )	Preamp Factor ( dB )	Ant Pos ( cm )	Table Pos ( deg )	Remark
2413	101.21	-	-	97.12	31.93	6.49	34.33	200	84	Average
2413	106.31	-	-	102.22	31.93	6.49	34.33	200	84	Peak
4824	47.4	-26.6	74	58.42	34.4	10.17	55.59	100	0	Peak



<b>Test Mode :</b>	802.11b	<b>Temperature :</b>	24~25°C
<b>Test Channel :</b>	06	<b>Relative Humidity :</b>	46~47%
<b>Test Engineer :</b>	Gavin Wu	<b>Polarization :</b>	Horizontal
<b>Remark :</b>	1. 2438 MHz is fundamental signal which can be ignored. 2. Average measurement was not performed if peak level went lower than the average limit.		

Frequency ( MHz )	Level ( dBμV/m )	Over Limit ( dB )	Limit Line ( dBμV/m )	Read Level ( dBμV )	Antenna Factor ( dB )	Cable Loss ( dB )	Preamp Factor ( dB )	Ant Pos ( cm )	Table Pos ( deg )	Remark
2438	104.09	-	-	99.93	31.96	6.52	34.32	196	63	Average
2438	108.54	-	-	104.38	31.96	6.52	34.32	196	63	Peak
4875	47.46	-26.54	74	58.59	34.37	10.18	55.68	100	0	Peak
7311	48.27	-25.73	74	58	35.61	10.94	56.28	100	0	Peak

<b>Test Mode :</b>	802.11b	<b>Temperature :</b>	24~25°C
<b>Test Channel :</b>	06	<b>Relative Humidity :</b>	46~47%
<b>Test Engineer :</b>	Gavin Wu	<b>Polarization :</b>	Vertical
<b>Remark :</b>	1. 2438 MHz is fundamental signal which can be ignored. 2. Average measurement was not performed if peak level went lower than the average limit.		

Frequency ( MHz )	Level ( dBμV/m )	Over Limit ( dB )	Limit Line ( dBμV/m )	Read Level ( dBμV )	Antenna Factor ( dB )	Cable Loss ( dB )	Preamp Factor ( dB )	Ant Pos ( cm )	Table Pos ( deg )	Remark
2438	102.84	-	-	98.68	31.96	6.52	34.32	195	82	Average
2438	107.7	-	-	103.54	31.96	6.52	34.32	195	82	Peak
4875	47.05	-26.95	74	58.18	34.37	10.18	55.68	100	0	Peak
7311	48.12	-25.88	74	57.85	35.61	10.94	56.28	100	0	Peak



<b>Test Mode :</b>	802.11b	<b>Temperature :</b>	24~25°C
<b>Test Channel :</b>	11	<b>Relative Humidity :</b>	46~47%
<b>Test Engineer :</b>	Gavin Wu	<b>Polarization :</b>	Horizontal
<b>Remark :</b>	1. 2463 MHz is fundamental signal which can be ignored. 2. Average measurement was not performed if peak level went lower than the average limit.		

Frequency ( MHz )	Level ( dBμV/m )	Over Limit ( dB )	Limit Line ( dBμV/m )	Read Level ( dBμV )	Antenna Factor ( dB )	Cable Loss ( dB )	Preamp Factor ( dB )	Ant Pos ( cm )	Table Pos ( deg )	Remark
2463	103.33	-	-	99.11	31.97	6.56	34.31	194	65	Average
2463	108.41	-	-	104.19	31.97	6.56	34.31	194	65	Peak
4923	47.44	-26.56	74	58.68	34.34	10.2	55.78	100	0	Peak
7386	48.31	-25.69	74	57.94	35.56	10.92	56.11	100	0	Peak

<b>Test Mode :</b>	802.11b	<b>Temperature :</b>	24~25°C
<b>Test Channel :</b>	11	<b>Relative Humidity :</b>	46~47%
<b>Test Engineer :</b>	Gavin Wu	<b>Polarization :</b>	Vertical
<b>Remark :</b>	1. 2462 MHz is fundamental signal which can be ignored. 2. Average measurement was not performed if peak level went lower than the average limit.		

Frequency ( MHz )	Level ( dBμV/m )	Over Limit ( dB )	Limit Line ( dBμV/m )	Read Level ( dBμV )	Antenna Factor ( dB )	Cable Loss ( dB )	Preamp Factor ( dB )	Ant Pos ( cm )	Table Pos ( deg )	Remark
2462	102.39	-	-	98.17	31.97	6.56	34.31	193	81	Average
2462	106.89	-	-	102.67	31.97	6.56	34.31	193	81	Peak
4923	46.51	-27.49	74	57.75	34.34	10.2	55.78	100	0	Peak
7386	48.55	-25.45	74	58.18	35.56	10.92	56.11	100	0	Peak



<b>Test Mode :</b>	802.11g	<b>Temperature :</b>	24~25°C
<b>Test Channel :</b>	01	<b>Relative Humidity :</b>	46~47%
<b>Test Engineer :</b>	Gavin Wu	<b>Polarization :</b>	Horizontal
<b>Remark :</b>	1. 2413 MHz is fundamental signal which can be ignored. 2. Average measurement was not performed if peak level went lower than the average limit.		

Frequency ( MHz )	Level ( dBμV/m )	Over Limit ( dB )	Limit Line ( dBμV/m )	Read Level ( dBμV )	Antenna Factor ( dB )	Cable Loss ( dB )	Preamp Factor ( dB )	Ant Pos ( cm )	Table Pos ( deg )	Remark
2413	95.78	-	-	91.69	31.93	6.49	34.33	104	134	Average
2413	106.08	-	-	101.99	31.93	6.49	34.33	104	134	Peak
4824	47.2	-26.8	74	58.22	34.4	10.17	55.59	100	0	Peak

<b>Test Mode :</b>	802.11g	<b>Temperature :</b>	24~25°C
<b>Test Channel :</b>	01	<b>Relative Humidity :</b>	46~47%
<b>Test Engineer :</b>	Gavin Wu	<b>Polarization :</b>	Vertical
<b>Remark :</b>	1. 2413 MHz is fundamental signal which can be ignored. 2. Average measurement was not performed if peak level went lower than the average limit.		

Frequency ( MHz )	Level ( dBμV/m )	Over Limit ( dB )	Limit Line ( dBμV/m )	Read Level ( dBμV )	Antenna Factor ( dB )	Cable Loss ( dB )	Preamp Factor ( dB )	Ant Pos ( cm )	Table Pos ( deg )	Remark
2413	95.25	-	-	91.16	31.93	6.49	34.33	200	80	Average
2413	105.87	-	-	101.78	31.93	6.49	34.33	200	80	Peak
4824	47.35	-26.65	74	58.37	34.4	10.17	55.59	100	0	Peak



<b>Test Mode :</b>	802.11g	<b>Temperature :</b>	24~25°C
<b>Test Channel :</b>	06	<b>Relative Humidity :</b>	46~47%
<b>Test Engineer :</b>	Gavin Wu	<b>Polarization :</b>	Horizontal
<b>Remark :</b>	1. 2438 MHz is fundamental signal which can be ignored. 2. Average measurement was not performed if peak level went lower than the average limit.		

Frequency ( MHz )	Level ( dBμV/m )	Over Limit ( dB )	Limit Line ( dBμV/m )	Read Level ( dBμV )	Antenna Factor ( dB )	Cable Loss ( dB )	Preamp Factor ( dB )	Ant Pos ( cm )	Table Pos ( deg )	Remark
2438	96.14	-	-	91.98	31.96	6.52	34.32	101	144	Average
2438	107.09	-	-	102.93	31.96	6.52	34.32	101	144	Peak
4875	46.89	-27.11	74	58.02	34.37	10.18	55.68	100	0	Peak
7311	48.93	-25.07	74	58.66	35.61	10.94	56.28	100	0	Peak

<b>Test Mode :</b>	802.11g	<b>Temperature :</b>	24~25°C
<b>Test Channel :</b>	06	<b>Relative Humidity :</b>	46~47%
<b>Test Engineer :</b>	Gavin Wu	<b>Polarization :</b>	Vertical
<b>Remark :</b>	1. 2438 MHz is fundamental signal which can be ignored. 2. Average measurement was not performed if peak level went lower than the average limit.		

Frequency ( MHz )	Level ( dBμV/m )	Over Limit ( dB )	Limit Line ( dBμV/m )	Read Level ( dBμV )	Antenna Factor ( dB )	Cable Loss ( dB )	Preamp Factor ( dB )	Ant Pos ( cm )	Table Pos ( deg )	Remark
2438	96	-	-	91.84	31.96	6.52	34.32	195	81	Average
2438	106.71	-	-	102.55	31.96	6.52	34.32	195	81	Peak
4875	46.78	-27.22	74	57.91	34.37	10.18	55.68	100	0	Peak
7311	47.38	-26.62	74	57.11	35.61	10.94	56.28	100	0	Peak



<b>Test Mode :</b>	802.11g	<b>Temperature :</b>	24~25°C
<b>Test Channel :</b>	11	<b>Relative Humidity :</b>	46~47%
<b>Test Engineer :</b>	Gavin Wu	<b>Polarization :</b>	Horizontal
<b>Remark :</b>	1. 2461 MHz is fundamental signal which can be ignored. 2. Average measurement was not performed if peak level went lower than the average limit.		

Frequency ( MHz )	Level ( dBμV/m )	Over Limit ( dB )	Limit Line ( dBμV/m )	Read Level ( dBμV )	Antenna Factor ( dB )	Cable Loss ( dB )	Preamp Factor ( dB )	Ant Pos ( cm )	Table Pos ( deg )	Remark
44.04	34.66	-5.34	40	55.42	10.26	0.76	31.78	-	-	Peak
122.34	22.17	-21.33	43.5	40.57	12.12	1.23	31.75	-	-	Peak
259.5	30.59	-15.41	46	46.63	13.9	1.79	31.73	-	-	Peak
454	41.74	-4.26	46	54.28	17.02	2.32	31.88	-	-	Peak
489	37.36	-8.64	46	49.21	17.69	2.38	31.92	-	-	Peak
525.4	41.83	-4.17	46	53.09	18.18	2.52	31.96	102	207	Peak
2461	95.93	-	-	91.71	31.97	6.56	34.31	106	144	Average
2461	106.76	-	-	102.54	31.97	6.56	34.31	106	144	Peak
4923	47.34	-26.66	74	58.58	34.34	10.2	55.78	100	0	Peak
7386	47.96	-26.04	74	57.59	35.56	10.92	56.11	100	0	Peak



<b>Test Mode :</b>	802.11g	<b>Temperature :</b>	24~25°C
<b>Test Channel :</b>	11	<b>Relative Humidity :</b>	46~47%
<b>Test Engineer :</b>	Gavin Wu	<b>Polarization :</b>	Vertical
<b>Remark :</b>	1. 2463 MHz is fundamental signal which can be ignored. 2. Average measurement was not performed if peak level went lower than the average limit.		

Frequency ( MHz )	Level ( dBμV/m )	Over Limit ( dB )	Limit Line ( dBμV/m )	Read Level ( dBμV )	Antenna Factor ( dB )	Cable Loss ( dB )	Preamp Factor ( dB )	Ant Pos ( cm )	Table Pos ( deg )	Remark
34.05	32.43	-7.57	40	47.44	16.1	0.68	31.79	-	-	Peak
85.35	26.15	-13.85	40	49.09	7.8	1.02	31.76	-	-	Peak
217.65	21.36	-24.64	46	42.32	9.17	1.61	31.74	-	-	Peak
454	37.76	-8.24	46	50.3	17.02	2.32	31.88	-	-	Peak
525.4	41.41	-4.59	46	52.67	18.18	2.52	31.96	100	250	Peak
531	40.52	-5.48	46	51.6	18.37	2.52	31.97	-	-	Peak
2463	95.85	-	-	91.63	31.97	6.56	34.31	193	87	Average
2463	106.71	-	-	102.49	31.97	6.56	34.31	193	87	Peak
4923	47.64	-26.36	74	58.88	34.34	10.2	55.78	100	0	Peak
7386	48.03	-25.97	74	57.66	35.56	10.92	56.11	100	0	Peak



<b>Test Mode :</b>	2.4GHz 802.11n HT20	<b>Temperature :</b>	24~25°C
<b>Test Channel :</b>	01	<b>Relative Humidity :</b>	46~47%
<b>Test Engineer :</b>	Gavin Wu	<b>Polarization :</b>	Horizontal
<b>Remark :</b>	1. 2413 MHz is fundamental signal which can be ignored. 2. Average measurement was not performed if peak level went lower than the average limit.		

Frequency ( MHz )	Level ( dBμV/m )	Over Limit ( dB )	Limit Line ( dBμV/m )	Read Level ( dBμV )	Antenna Factor ( dB )	Cable Loss ( dB )	Preamp Factor ( dB )	Ant Pos ( cm )	Table Pos ( deg )	Remark
2413	95.55	-	-	91.46	31.93	6.49	34.33	196	62	Average
2413	106.1	-	-	102.01	31.93	6.49	34.33	196	62	Peak
4824	46.5	-27.5	74	57.52	34.4	10.17	55.59	100	0	Peak

<b>Test Mode :</b>	2.4GHz 802.11n HT20	<b>Temperature :</b>	24~25°C
<b>Test Channel :</b>	01	<b>Relative Humidity :</b>	46~47%
<b>Test Engineer :</b>	Gavin Wu	<b>Polarization :</b>	Vertical
<b>Remark :</b>	1. 2413 MHz is fundamental signal which can be ignored. 2. Average measurement was not performed if peak level went lower than the average limit.		

Frequency ( MHz )	Level ( dBμV/m )	Over Limit ( dB )	Limit Line ( dBμV/m )	Read Level ( dBμV )	Antenna Factor ( dB )	Cable Loss ( dB )	Preamp Factor ( dB )	Ant Pos ( cm )	Table Pos ( deg )	Remark
2413	94.43	-	-	90.34	31.93	6.49	34.33	200	87	Average
2413	105.71	-	-	101.62	31.93	6.49	34.33	200	87	Peak
4824	46.96	-27.04	74	57.98	34.4	10.17	55.59	100	0	Peak



<b>Test Mode :</b>	2.4GHz 802.11n HT20	<b>Temperature :</b>	24~25°C
<b>Test Channel :</b>	06	<b>Relative Humidity :</b>	46~47%
<b>Test Engineer :</b>	Gavin Wu	<b>Polarization :</b>	Horizontal
<b>Remark :</b>	1. 2438 MHz is fundamental signal which can be ignored. 2. Average measurement was not performed if peak level went lower than the average limit.		

Frequency ( MHz )	Level ( dBμV/m )	Over Limit ( dB )	Limit Line ( dBμV/m )	Read Level ( dBμV )	Antenna Factor ( dB )	Cable Loss ( dB )	Preamp Factor ( dB )	Ant Pos ( cm )	Table Pos ( deg )	Remark
2438	95.67	-	-	91.51	31.96	6.52	34.32	196	62	Average
2438	106.95	-	-	102.79	31.96	6.52	34.32	196	62	Peak
4875	47.04	-26.96	74	58.17	34.37	10.18	55.68	100	0	Peak
7311	47.4	-26.6	74	57.13	35.61	10.94	56.28	100	0	Peak

<b>Test Mode :</b>	2.4GHz 802.11n HT20	<b>Temperature :</b>	24~25°C
<b>Test Channel :</b>	06	<b>Relative Humidity :</b>	46~47%
<b>Test Engineer :</b>	Gavin Wu	<b>Polarization :</b>	Vertical
<b>Remark :</b>	1. 2438 MHz is fundamental signal which can be ignored. 2. Average measurement was not performed if peak level went lower than the average limit.		

Frequency ( MHz )	Level ( dBμV/m )	Over Limit ( dB )	Limit Line ( dBμV/m )	Read Level ( dBμV )	Antenna Factor ( dB )	Cable Loss ( dB )	Preamp Factor ( dB )	Ant Pos ( cm )	Table Pos ( deg )	Remark
2438	94.93	-	-	90.77	31.96	6.52	34.32	198	94	Average
2438	106.05	-	-	101.89	31.96	6.52	34.32	198	94	Peak
4875	47.36	-26.64	74	58.49	34.37	10.18	55.68	100	0	Peak
7311	48.11	-25.89	74	57.84	35.61	10.94	56.28	100	0	Peak



<b>Test Mode :</b>	2.4GHz 802.11n HT20	<b>Temperature :</b>	24~25°C
<b>Test Channel :</b>	11	<b>Relative Humidity :</b>	46~47%
<b>Test Engineer :</b>	Gavin Wu	<b>Polarization :</b>	Horizontal
<b>Remark :</b>	1. 2463 MHz is fundamental signal which can be ignored. 2. Average measurement was not performed if peak level went lower than the average limit.		

Frequency ( MHz )	Level ( dBμV/m )	Over Limit ( dB )	Limit Line ( dBμV/m )	Read Level ( dBμV )	Antenna Factor ( dB )	Cable Loss ( dB )	Preamp Factor ( dB )	Ant Pos ( cm )	Table Pos ( deg )	Remark
35.94	30.62	-9.38	40	46.73	14.98	0.7	31.79	-	-	Peak
173.64	23.64	-19.86	43.5	44.19	9.64	1.56	31.75	-	-	Peak
259.5	30.83	-15.17	46	46.87	13.9	1.79	31.73	-	-	Peak
454	41.4	-4.6	46	53.94	17.02	2.32	31.88	-	-	Peak
525.4	41.73	-4.27	46	52.99	18.18	2.52	31.96	102	193	Peak
534.5	39.36	-6.64	46	50.15	18.66	2.52	31.97	-	-	Peak
2463	96.24	-	-	92.02	31.97	6.56	34.31	195	67	Average
2463	107.02	-	-	102.8	31.97	6.56	34.31	195	67	Peak
4923	46.91	-27.09	74	58.15	34.34	10.2	55.78	100	0	Peak
7386	48	-26	74	57.63	35.56	10.92	56.11	100	0	Peak



<b>Test Mode :</b>	2.4GHz 802.11n HT20	<b>Temperature :</b>	24~25°C
<b>Test Channel :</b>	11	<b>Relative Humidity :</b>	46~47%
<b>Test Engineer :</b>	Gavin Wu	<b>Polarization :</b>	Vertical
<b>Remark :</b>	1. 2463 MHz is fundamental signal which can be ignored. 2. Average measurement was not performed if peak level went lower than the average limit.		

Frequency ( MHz )	Level ( dBμV/m )	Over Limit ( dB )	Limit Line ( dBμV/m )	Read Level ( dBμV )	Antenna Factor ( dB )	Cable Loss ( dB )	Preamp Factor ( dB )	Ant Pos ( cm )	Table Pos ( deg )	Remark
34.05	33.05	-6.95	40	48.06	16.1	0.68	31.79	-	-	Peak
39.45	31.88	-8.12	40	50.03	12.9	0.74	31.79	-	-	Peak
86.16	26.68	-13.32	40	49.45	7.96	1.03	31.76	-	-	Peak
454	37.65	-8.35	46	50.19	17.02	2.32	31.88	-	-	Peak
522.6	40.41	-5.59	46	51.77	18.09	2.51	31.96	100	248	Peak
531	40.1	-5.9	46	51.18	18.37	2.52	31.97	-	-	Peak
2463	95.3	-	-	91.08	31.97	6.56	34.31	194	91	Average
2463	106.45	-	-	102.23	31.97	6.56	34.31	194	91	Peak
4923	47.98	-26.02	74	59.22	34.34	10.2	55.78	100	0	Peak
7386	48.1	-25.9	74	57.73	35.56	10.92	56.11	100	0	Peak



### 3.6 AC Conducted Emission Measurement

#### 3.6.1 Limit of AC Conducted Emission

For equipment that is designed to be connected to the public utility (AC) power line, the radio frequency voltage that is conducted back onto the AC power line on any frequency or frequencies within the band 150 kHz to 30 MHz shall not exceed the limits in the following table.

Frequency of Emission (MHz)	Conducted Limit (dBµV)	
	Quasi-Peak	Average
0.15-0.5	66 to 56*	56 to 46*
0.5-5	56	46
5-30	60	50

\*Decreases with the logarithm of the frequency.

#### 3.6.2 Measuring Instruments

The measuring equipment is listed in the section 4 of this test report.

#### 3.6.3 Test Procedures

1. The EUT was placed 0.4 meter from the conducting wall of the shielding room, and it was kept at least 80 centimeters from any other grounded conducting surface.
2. Connect EUT to the power mains through a line impedance stabilization network (LISN).
3. All the support units are connecting to the other LISN.
4. The LISN provides 50 ohm coupling impedance for the measuring instrument.
5. The FCC states that a 50 ohm, 50 microhenry LISN should be used.
6. Both sides of AC line were checked for maximum conducted interference.
7. The frequency range from 150 kHz to 30 MHz was searched.
8. Set the test-receiver system to Peak Detect Function and specified bandwidth with Maximum Hold Mode.

### 3.6.4 Test Setup

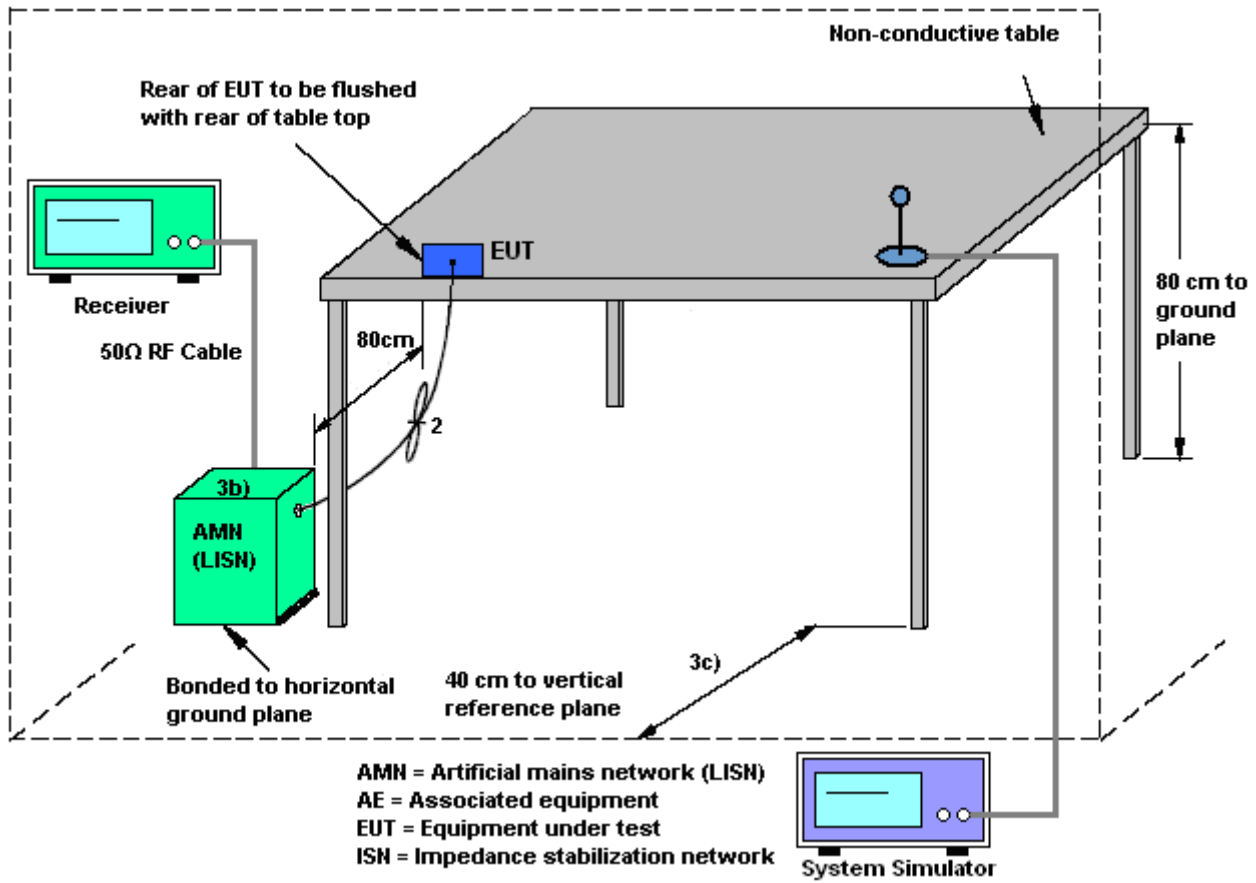

3.6.5 Test Result of AC Conducted Emission

Test Mode :	Mode 1	Temperature :	20~22°C
Test Engineer :	Cosmo Hsu	Relative Humidity :	45~47%
Test Voltage :	120Vac / 60Hz	Phase :	Line
Function Type :	GSM850 Idle + Bluetooth Link + WLAN Link + MP3 + Earphone + Battery + Adapter		

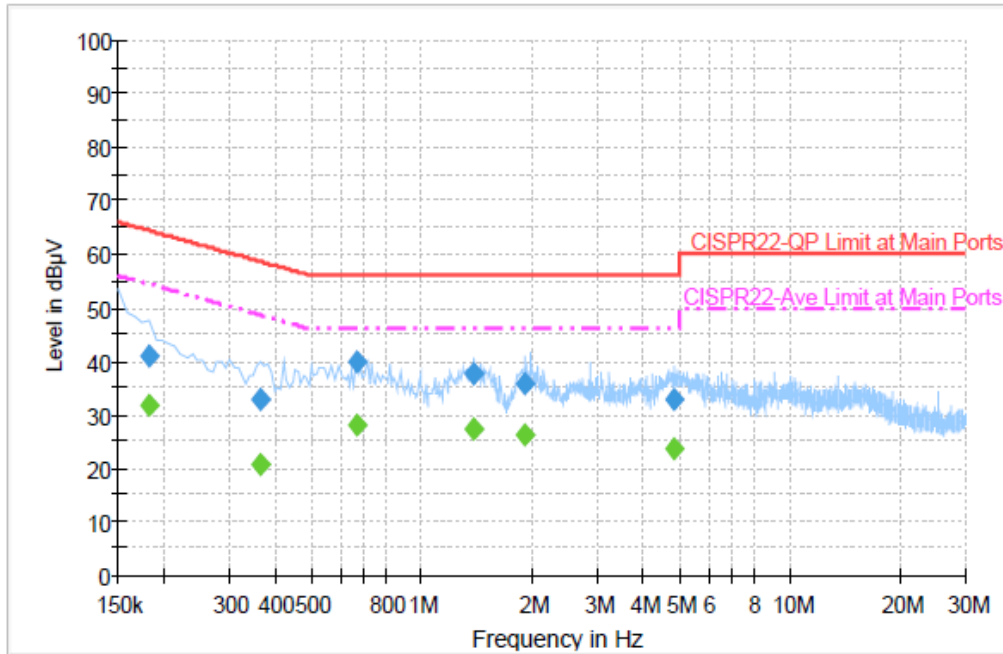

Final Result : Quasi-Peak

Frequency (MHz)	Quasi-Peak (dBµV)	Filter	Line	Corr. (dB)	Margin (dB)	Limit (dBµV)
0.182000	40.9	Off	L1	19.3	23.5	64.4
0.366000	32.9	Off	L1	19.4	25.7	58.6
0.670000	39.8	Off	L1	19.5	16.2	56.0
1.390000	37.6	Off	L1	19.5	18.4	56.0
1.902000	35.9	Off	L1	19.6	20.1	56.0
4.830000	32.8	Off	L1	19.6	23.2	56.0

Final Result : Average

Frequency (MHz)	Average (dBµV)	Filter	Line	Corr. (dB)	Margin (dB)	Limit (dBµV)
0.182000	31.7	Off	L1	19.3	22.7	54.4
0.366000	20.7	Off	L1	19.4	27.9	48.6
0.670000	28.0	Off	L1	19.5	18.0	46.0
1.390000	27.2	Off	L1	19.5	18.8	46.0
1.902000	26.1	Off	L1	19.6	19.9	46.0
4.830000	23.7	Off	L1	19.6	22.3	46.0



Test Mode :	Mode 1	Temperature :	20~22°C
Test Engineer :	Cosmo Hsu	Relative Humidity :	45~47%
Test Voltage :	120Vac / 60Hz	Phase :	Neutral
Function Type :	GSM850 Idle + Bluetooth Link + WLAN Link + MP3 + Earphone + Battery + Adapter		

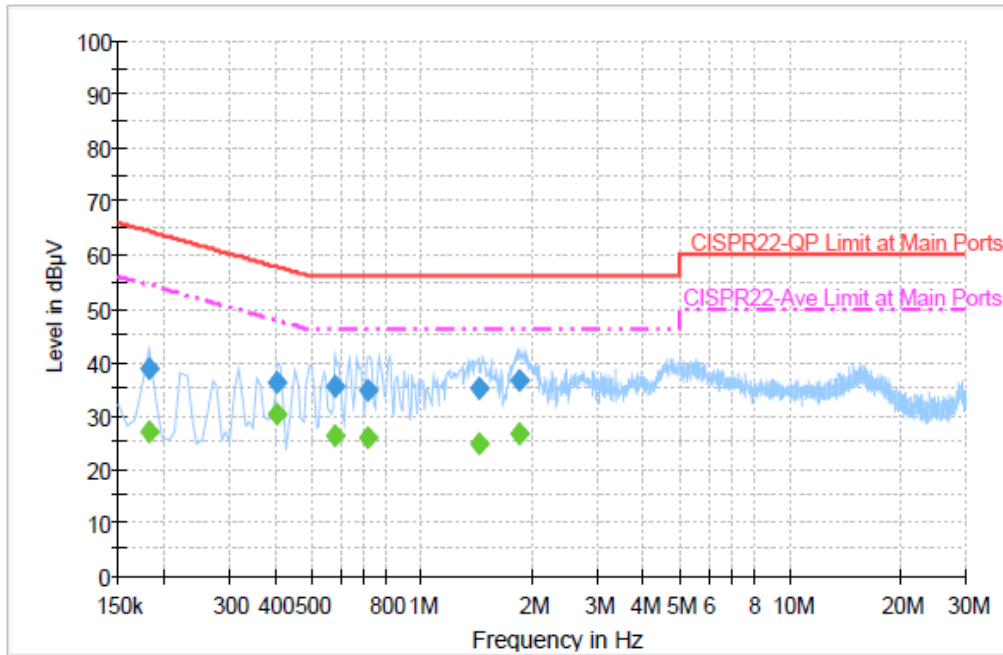

**Final Result : Quasi-Peak**

Frequency (MHz)	Quasi-Peak (dBµV)	Filter	Line	Corr. (dB)	Margin (dB)	Limit (dBµV)
0.182000	38.9	Off	N	19.3	25.5	64.4
0.406000	36.2	Off	N	19.4	21.5	57.7
0.582000	35.5	Off	N	19.4	20.5	56.0
0.718000	34.6	Off	N	19.5	21.4	56.0
1.430000	35.1	Off	N	19.5	20.9	56.0
1.830000	36.5	Off	N	19.6	19.5	56.0

**Final Result : Average**

Frequency (MHz)	Average (dBµV)	Filter	Line	Corr. (dB)	Margin (dB)	Limit (dBµV)
0.182000	27.1	Off	N	19.3	27.3	54.4
0.406000	30.2	Off	N	19.4	17.5	47.7
0.582000	26.0	Off	N	19.4	20.0	46.0
0.718000	25.8	Off	N	19.5	20.2	46.0
1.430000	24.6	Off	N	19.5	21.4	46.0
1.830000	26.5	Off	N	19.6	19.5	46.0



## **3.7 Antenna Requirements**

### **3.7.1 Standard Applicable**

If directional gain of transmitting antennas is greater than 6dBi, the power shall be reduced by the same level in dB comparing to gain minus 6dBi. For the fixed point-to-point operation, the power shall be reduced by one dB for every 3 dB that the directional gain of the antenna exceeds 6 dBi. The use of a permanently attached antenna or of an antenna that uses a unique coupling to the intentional radiator shall be considered sufficient to comply with the FCC rule.

### **3.7.2 Antenna Anti-Replacement Construction**

An embedded-in antenna design is used.

### **3.7.3 Antenna Gain**

The antenna peak gain of EUT is less than 6 dBi. Therefore, it is not necessary to reduce maximum peak output power limit.



## 4 List of Measuring Equipment

Instrument	Manufacturer	Model No.	Serial No.	Characteristics	Calibration Date	Test Date	Due Date	Remark
Spectrum Analyzer	Rohde & Schwarz	FSP40	100055	9kHz~40GHz	Jun. 07, 2013	Mar. 26, 2014 ~ Apr. 01, 2014	Jun. 06, 2014	Conducted (TH02-HY)
Power Meter	Anritsu	ML2495A	1036004	300MHz~40GHz	Aug. 17, 2013	Mar. 26, 2014 ~ Apr. 01, 2014	Aug. 16, 2014	Conducted (TH02-HY)
Power Sensor	Anritsu	MA2411B	1027253	300MHz~40GHz	Aug. 17, 2013	Mar. 26, 2014 ~ Apr. 01, 2014	Aug. 16, 2014	Conducted (TH02-HY)
Spectrum Analyzer	R&S	FSP30	101067	9kHz ~ 30GHz	Nov. 20, 2013	Mar. 29, 2014	Nov. 19, 2014	Radiation (03CH06-HY)
Spectrum Analyzer	Agilent	E4408B	MY44211030	9kHz ~ 26.5GHz	Dec. 02, 2013	Mar. 29, 2014	Dec. 01, 2014	Radiation (03CH06-HY)
EMI Test Receiver	R&S	ESVS10	834468/0003	20MHz ~ 1000MHz	May 06, 2013	Mar. 29, 2014	May 05, 2014	Radiation (03CH06-HY)
Loop Antenna	Rohde & Schwarz	HFH2-Z2	860004/0001	9kHz ~ 30MHz	Jul. 03, 2012	Mar. 29, 2014	Jul. 02, 2014	Radiation (03CH06-HY)
Bilog Antenna	Schaffner	CBL6112B	2885	30MHz ~ 2GHz	Oct. 10, 2013	Mar. 29, 2014	Oct. 09, 2014	Radiation (03CH06-HY)
Double Ridge Horn Antenna	EMCO	3117	00066583	1GHz ~ 18GHz	Aug. 02, 2013	Mar. 29, 2014	Aug. 01, 2014	Radiation (03CH06-HY)
Amplifier	Agilent	310N	186713	9kHz ~ 1GHz	Apr. 12, 2013	Mar. 29, 2014	Apr. 11, 2014	Radiation (03CH06-HY)
Pre Amplifier	EMCI	EMC051845	SN980048	1GHz ~ 18GHz	Jul. 18, 2013	Mar. 29, 2014	Jul. 17, 2014	Radiation (03CH06-HY)
SHF-EHF Horn Antenna	SCHWARZBECK	BBHA 9170	BBHA9170251	15GHz ~ 40GHz	Oct. 03, 2013	Mar. 29, 2014	Oct. 02, 2014	Radiation (03CH06-HY)
Preamplifier	Agilent	8449B	3008A01917	1GHz ~ 26.5GHz	Apr. 12, 2013	Mar. 29, 2014	Apr. 11, 2014	Radiation (03CH06-HY)
Turn Table	INN-CO	DS2000	420/650/00	0 ~ 360 degree	N/A	Mar. 29, 2014	N/A	Radiation (03CH06-HY)
Antenna Mast	MF	MF-7802	MF780208212	1 m ~ 4 m	N/A	Mar. 29, 2014	N/A	Radiation (03CH06-HY)
EMI Test Receiver	Rohde & Schwarz	ESCS 30	100356	9kHz ~ 2.75GHz	Nov. 15, 2013	Mar. 26, 2014	Nov. 14, 2014	Conduction (CO05-HY)
LISN (for auxiliary equipment)	Rohde & Schwarz	ENV216	100081	9kHz ~ 30MHz	Dec. 12, 2013	Mar. 26, 2014	Dec. 11, 2014	Conduction (CO05-HY)
LISN	Rohde & Schwarz	ENV216	100080	9kHz ~ 30MHz	Dec. 04, 2013	Mar. 26, 2014	Dec. 03, 2014	Conduction (CO05-HY)
AC Power Source	ChainTek	APC-1000W	N/A	N/A	N/A	Mar. 26, 2014	N/A	Conduction (CO05-HY)



## 5 Uncertainty of Evaluation

### Uncertainty of Conducted Emission Measurement (150kHz ~ 30MHz)

Measuring Uncertainty for a Level of Confidence of 95% ( $U = 2Uc(y)$ )	2.26
---	------

### Uncertainty of Radiated Emission Measurement (30 MHz ~ 1000 MHz)

Measuring Uncertainty for a Level of Confidence of 95% ( $U = 2Uc(y)$ )	4.50
---	------