



# MOTOROLA

## Portable Cellular Phone SAR Test Report

**Tests Requested By:** Motorola Mobility, Inc.  
600 N. US Highway 45  
Libertyville, IL 60048

**Test Report #:** 25086-1F  
**Date of Report:** Aug-07-2012  
**Date of Test:** Jun-27-2012 to Jul-21-2012  
**FCC ID #:** IHDT56NS1  
**Generic Name:** M0D34

**Test Laboratory:** Motorola Mobility, Inc. - ADR Test Services Laboratory  
600 N. US Highway 45  
Libertyville, IL 60048

**Report Author:** Thomas Knipple  
Senior Staff Test Engineer

This laboratory is accredited to ISO/IEC 17025-2005 to perform the following tests:

**Accreditation:**



2404

Tests:

Electromagnetic Specific Absorption Rate

Procedures:

IEC 62209-1

RSS-102

IEEE 1528 - 2003

FCC OET Bulletin 65 (*including Supplement C*)

Australian Communications Authority Radio

Communications (Electromagnetic Radiation –  
Human Exposure) Standard 2003

CENELEC EN 50360

ARIB Std. T-56 (2002)

On the following products or types of products:

Wireless Communications Devices (Examples): Two Way Radios; Portable Phones (including Cellular, Licensed Non-Broadcast and PCS); Low Frequency Readers; and Pagers

**Statement of Compliance:**

Motorola declares under its sole responsibility that the portable cellular telephone model to which this declaration relates, is in conformity with the appropriate General Population/Uncontrolled RF exposure standards, recommendations and guidelines (FCC 47 CFR §2.1093) as well as with CENELEC en50360:2001 and ANSI / IEEE C95.1. It also declares that the product was tested in accordance with IEEE 1528 / CENELEC EN62209-1 (2006), as well as other appropriate measurement standards, guidelines and recommended practices. Any deviations from these standards, guidelines and recommended practices are noted below:

(none)

©Motorola Mobility, Inc. 2012

This test report shall not be reproduced except in full, without written approval of the laboratory. The results and statements contained herein relate only to the items tested. The names of individuals involved may be mentioned only in connection with the statements or results from this report. Motorola encourages all feedback, both positive and negative, on this test report.

## Table of Contents

**1. Introduction .....3**

**2. Description of the Device Under Test .....4**

    2.1 Antenna description..... 4

    2.2 Device Signaling..... 5

        2.2.1 LTE Device Description.....6

        2.2.2 Transmitter power reduction conditions and modes.....8

    2.3 Device Conducted Power Measurements .....10

        2.3.1 LTE modes .....10

        2.3.2 CDMA modes.....10

        2.3.3 Wi-Fi 802.11 modes .....11

        2.3.4 Bluetooth modes and test exclusion .....13

**3. Test Equipment Used .....14**

    3.1 Dosimetric System .....14

    3.2 Additional Equipment.....14

**4. Electrical parameters of the tissue simulating liquid .....15**

**5. System Accuracy Verifications.....17**

**6. Test Results .....19**

    6.1 Head Adjacent Test Results .....20

    6.2 Body-Worn Accessory Test Results .....29

    6.3 Mobile Hotspot Test Results .....32

    6.4 Description and Evaluation of Simultaneous Transmitters.....39

**References .....46**

**Appendix 1: SAR distribution comparisons for System Accuracy Verifications**

**Appendix 2: SAR distribution plots for Head Adjacent Test Results**

**Appendix 3: SAR distribution plots for Body Worn Test Results**

**Appendix 4: SAR distribution plots for Mobile Hotspot Test Results**

**Appendix 5: Measurement Uncertainty Budget**

**Appendix 6: Probe Calibration Certificate**

**Appendix 7: Dipole Characterization Certificate**

### Revision History

Revision Version	Date	Notes
Rev. 0	Jul-27-2012	Initial report release
Rev. A	Aug-07-2012	Updated per TCB inquiry

## 1. Introduction

The Motorola Mobility ADR Test Services Laboratory has performed measurements of the maximum potential exposure to the user of the portable cellular phone covered by this test report. The Specific Absorption Rate (SAR) of this product was measured. The portable cellular phone was tested in accordance with [1], [4] and [5]. The SAR values measured for the portable cellular phone are below the maximum recommended levels of 1.6 W/kg in a 1 g average set in [3] and 2.0 W/kg in a 10 g average set in [2].

For ANSI / IEEE C95.1 (1 g), the final stand-alone SAR readings for this phone are given in the table below. For ANSI / IEEE C95.1 (1 g), the final simultaneous-transmission SAR readings (by summation) for this phone are 1.37 W/kg for head-adjacent use, 0.90 W/kg for body-worn accessory use, and 1.29 W/kg for mobile hotspot operation. These measurements were performed using a DASY4™ v4.7 or DASY52™ system manufactured by Schmid & Partner Engineering AG (SPEAG), of Zurich Switzerland.

<b>Transmit Band</b>	<b>Head SAR (1 g<sup>W</sup>/kg)</b>	<b>Body-Worn Accessory SAR (1 g<sup>W</sup>/kg)</b>	<b>Mobile Hotspot SAR (1 g<sup>W</sup>/kg)</b>
<b>LTE Band 13</b>	<b>0.55</b>	<b>0.27</b>	<b>1.32</b>
<b>CDMA 800</b>	<b>0.69</b>	<b>0.61</b>	<b>1.04</b>
<b>CDMA 1900</b>	<b>1.28</b>	<b>0.63</b>	<b>1.10</b>
<b>Wi-Fi 2.45 GHz</b>	<b>1.30</b>	<b>0.08</b>	<b>0.07</b>
<b>Wi-Fi 5.2 GHz</b>	<b>0.53</b>	<b>0.09</b>	<b>N/A</b>
<b>Wi-Fi 5.8 GHz</b>	<b>0.47</b>	<b>0.10</b>	<b>0.10</b>

## 2. Description of the Device Under Test

### 2.1 Antenna description

#### Main Antenna [800/1900 MHz]

<b>Type</b>	Internal	
<b>Location</b>	Bottom of Transceiver	
<b>Dimensions</b>	Width	4.6 mm
	Length	56.1 mm

#### LTE Antenna [782 MHz]

<b>Type</b>	Internal	
<b>Location</b>	Left-Top Edge of Transceiver	
<b>Dimensions</b>	Width	18.9 mm
	Length	37.0 mm

#### Wi-Fi/Bluetooth Antenna [2.4 / 5 GHz]

<b>Type</b>	Internal	
<b>Location</b>	Right Edge of Transceiver	
<b>Dimensions</b>	Width	2.0 mm
	Length	22.7 mm

#### NFC Antenna [13.56 MHz]

<b>Type</b>	Internal	
<b>Location</b>	Center Rear of Transceiver	
<b>Dimensions</b>	Width	44.0 mm
	Length	46.0 mm

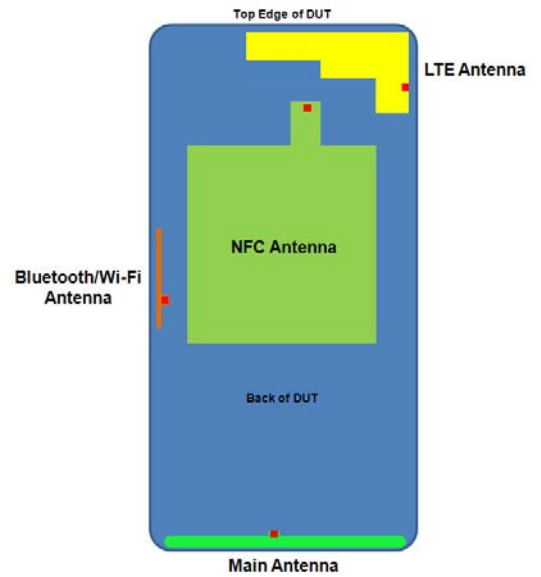

## 2.2 Device Signaling<sup>1,2</sup>

<b>Serial Number(s) (Functional Use)</b>	6554 6336 KSL00F0065	(CDMA conducted power measurements, CDMA SAR testing, Wi-Fi SAR testing) (LTE conducted power measurements, LTE SAR testing, Wi-Fi SAR testing) (WLAN conducted power measurements, Bluetooth conducted power measurements)
<b>Production Unit or Identical Prototype (47 CFR §2.908)</b>	Identical Prototype	
<b>Device Category</b>	Portable	
<b>RF Exposure Limits</b>	General Population / Uncontrolled	

Mode(s) of Operation	Modulation Mode(s)	Maximum Output Power Setting	Duty Cycle	Transmitting Frequency Range(s)
LTE Band 13	QPSK, 16QAM	24.0 dBm	1:1	782 MHz (1 Channel, 10 MHz wide)
CDMA 800	QPSK	25.0 dBm	1:1	824.70 – 848.31 MHz
CDMA 1900	QPSK	25.0 dBm	1:1	1851.20 – 1908.75 MHz
Wi-Fi 802.11b/g/n	BPSK	19.04 dBm	1:1	2412.0 - 2462.0 MHz
Wi-Fi 802.11a/n	BPSK	15.59 dBm	1:1	5180.0 - 5240.0 MHz, 5745.0 - 5825.0 MHz
Bluetooth	GFSK	8.63 dBm	1:1	2402.0 – 2480.0 MHz

<sup>1</sup> This device supports voice call functionality over GSM and WCDMA on non-US cellular networks. The GSM/WCDMA network functions have been disabled by firmware and are SIM locked for all US operators. Further information regarding this functionality is contained within Exhibit 12.

<sup>2</sup> This device contains an integrated Near Field Communications (NFC) module. Evaluation of SAR test requirements for the NFC transmitter was performed per the guidance in FCC KDB 447498, FCC KDB 865664 and FCC KDB 648474. FCC KDB 865664 specifies that the FCC SAR test requirements are applicable to 100 MHz - 6 GHz only, but states that numerical SAR simulation may be appropriate for transmit frequencies below 100 MHz. Additionally, KDB 447498 provides guidance on test exclusion based on maximum transmit power capabilities, which this NFC transmitter falls into. Finally, KDB 648474 states that "phones with built-in NFC, wireless charging or similar functions that do not require separate SAR testing for these specific capabilities can generally be tested according to the normally required SAR measurement procedures. The SAR influence of the additional accessory hardware and functionality to the transmitters and antennas that require SAR Testing are considered during the required SAR testing; therefore, it is transparent to the testing process." Therefore, no SAR measurements of the NFC transmitter are required.

## 2.2.1 LTE Device Description

### LTE Summary Information per FCC KDB 941225

<b>FCC ID</b>			IHDT56NS1
<b>Form Factor</b>			Handset
<b>Frequency Range</b>			777 MHz - 787 MHz
<b>Channel Bandwidths</b>			10 MHz
<b>L,M,H Channel Numbers and Frequencies</b>			
<b>Low</b>	<b>Mid</b>	<b>High</b>	
--	23230 (782 MHz)	--	
<b>UE Category</b>			1
<b>Modulations Supported</b>			QPSK, 16QAM
<b>Description of LTE Tx and Antenna Implementation</b>			1 TX Antenna; 2 RX Antenna
<b>LTE Voice Available?</b>			Yes (3 <sup>rd</sup> Party VOIP clients Only)
<b>Hotspot with LTE + Wi-Fi?</b>			Yes
<b>Hotspot with LTE + Wi-Fi active with 1x Voice sessions?</b>			Yes
<b>LTE MPR Permanently Implemented per 3GPP TS 36.101?</b>			Yes
<b>A-MPR disabled (by setting NS=01 on the R&amp;S CMW500)?</b>			Yes
<b>Conducted power table providing 1 RB (lower and upper edge), 50% RB (centered) and 100% RB</b>			Yes
<b>Table provided specifying other US wireless operating modes?</b>			Yes
<b>Table provided specifying maximum average conducted power for these other wireless modes</b>			Yes
<b>Table provided identifying simultaneous transmission conditions?</b>			Yes (see section 6.4)
<b>Power Reduction used for SAR compliance?</b>			Yes (see section 2.2.2)
<b>Power Reduction used for CDMA?</b>			Yes
<b>Power Reduction used for LTE?</b>			Yes
<b>Power Reduction used for svLTE?</b>			Yes
<b>Test Equipment used</b>			CMW500 SW version 2.1.26.3

LTE Maximum Power Reduction (MPR) conditions are defined in 3GPP 36-521, section 6.2.3.3:

### 6.2.3.3 Minimum conformance requirements

For UE Power Class 3, the allowed Maximum Power Reduction (MPR) for the maximum output power in Table 6.2.2.3-1 due to higher order modulation and transmit bandwidth configuration (resource blocks) is specified in Table 6.2.3.3-1.

**Table 6.2.3.3-1: Maximum Power Reduction (MPR) for Power Class 3**

Modulation	Channel bandwidth / Transmission bandwidth configuration [RB]						MPR (dB)
	1.4 MHz	3.0 MHz	5 MHz	10 MHz	15 MHz	20 MHz	
QPSK	> 5	> 4	> 8	> 12	> 16	> 18	≤ 1
16 QAM	≤ 5	≤ 4	≤ 8	≤ 12	≤ 16	≤ 18	≤ 1
16 QAM	> 5	> 4	> 8	> 12	> 16	> 18	≤ 2

For the UE maximum output power modified by MPR, the power limits specified in subclause 6.2.5.3 apply. The normative reference for this requirement is TS 36.101 clause 6.2.3.

For the DUT architecture, MPR is permanently implemented. Per the chart above, the following MPR is used:

Modulation	# of RBs	MPR (dB)
QPSK	> 12	1
16 QAM	≤ 12	1
16 QAM	> 12	2

The table applies for any RB start value. RBs are assigned contiguously. Thus, given a maximum power of 24 dBm and the MPR described above, the maximum power for the SAR test cases is as follows:

Test Case	Max Power (dBm)
QPSK, 50% RB Allocation	23
QPSK, 100% RB Allocation	23
QPSK, RB Allocation: 1 RB @ high channel edge	24
QPSK, RB Allocation: 1 RB @ low channel edge	24
16QAM, 50% RB Allocation	22
16QAM, 100% RB Allocation	22
16QAM, RB Allocation: 1 RB @ high channel edge	23
16QAM, RB Allocation: 1 RB @ low channel edge	23

Due to the device's design, MPR is only enabled when the device is operating under radiating conditions. Note that this prevents conducted power measurements of this functionality without modification to the unit.

## 2.2.2 Transmitter power reduction conditions and modes

The DUT utilizes reduced limits for the maximum transmit power for its transmitters when operating under the following noted conditions to ensure SAR exposure compliance is maintained. Tables of the reduced limits used for testing are given below. A complete description of this functionality is provided in the “Operational Description” contained within Exhibit 12. The implementation to trigger the reduction in power requires the device to be radiating, which prevents conducted power measurements of this functionality without modification to the unit.

For the Wi-Fi transmitter, reduced power limits are enforced under any condition where the Wi-Fi transmitter is operating simultaneously with any other transmitter(s). A table of the reduced limits used for testing is given below.

Mode(s) of Operation	Wi-Fi 2.4 GHz	Wi-Fi 5 GHz
Channel Ranges	1-11	36-165
Maximum Output Power Target (dBm)	18	16
Reduced Maximum Output Power Target (dBm)	12	11

For the LTE transmitter, reduced power limits are enforced while operating in a mobile hotspot session in body-adjacent configurations. A table of the reduced limits used for testing is given below.

Mode(s) of Operation	LTE Band 13							
Test Channel	23230							
Modulation	QPSK				16QAM			
RB Allocation	1 RB @LOW EDGE	1 RB @HIGH EDGE	50%	100%	1 RB @LOW EDGE	1 RB @HIGH EDGE	50%	100%
Maximum Output Power Setting (dBm)	24.0	24.0	24.0	24.0	24.0	24.0	24.0	24.0
Output Power Setting with MPR (dBm)	24.0	24.0	23.0	23.0	23.0	23.0	22.0	22.0
Reduced Maximum Output Power Setting (dBm)	22.0	22.0	22.0	22.0	22.0	22.0	22.0	22.0

The DUT supports Simultaneous Voice and LTE (SVLTE), allowing a 1x CDMA voice call while simultaneously providing an LTE link for data transport on the cellular network. While operating in SVLTE, *if the power on the 1x CDMA transmitter for voice is operating above 18.5 dBm*, a reduced maximum LTE transmit power limit is enforced to ensure SAR exposure compliance is maintained. When the power of the 1x CDMA transmitter is operating at or below 18.5 dBm or this combination of transmitters is not in use, the LTE transmitter operates up to its maximum power limit. Note that both conditions (1x CDMA above 18.5 dBm and LTE at reduced power, or 1x CDMA at or below 18.5 dBm with LTE at full power) are demonstrated for SAR compliance in section 6. A table of the reduced limits used for testing is given below.

Mode(s) of Operation	LTE Band 13							
Test Channel	23230							
Modulation	QPSK				16QAM			
RB Allocation	1 RB @LOW EDGE	1 RB @HIGH EDGE	50%	100%	1 RB @LOW EDGE	1 RB @HIGH EDGE	50%	100%
Maximum Output Power Setting (dBm)	24.0	24.0	24.0	24.0	24.0	24.0	24.0	24.0
Output Power Setting with MPR (dBm)	24.0	24.0	23.0	23.0	23.0	23.0	22.0	22.0
Reduced Maximum Output Power Setting (dBm)	17.0	17.0	17.0	17.0	17.0	17.0	17.0	17.0

The SVLTE feature may also operate concurrently during a mobile hotspot session. When operating with these features active in a body-adjacent configuration, the reduced maximum LTE transmit power limit is strictly enforced.

While operating in head-adjacent exposure configurations simultaneously with the Wi-Fi transmitter, a reduced maximum power limit is enforced on the CDMA 1900 transmitter. A table of the reduced limit used for testing is given below.

<b>Mode(s) of Operation</b>	CDMA 1900
<b>Channel Ranges</b>	25-1175
<b>Maximum Output Power Setting (dBm)</b>	25.0
<b>Reduced Maximum Output Power Setting (dBm)</b>	22.0

This reduced limit is also enforced when using SVLTE during a mobile hotspot session with the device held against the head.

While operating in body-adjacent exposure configurations simultaneously with the Wi-Fi transmitter, a reduced maximum power limit is enforced on the CDMA 1900 transmitter. A table of the reduced limit used for testing is given below.

<b>Mode(s) of Operation</b>	CDMA 1900
<b>Channel Ranges</b>	25-1175
<b>Maximum Output Power Setting (dBm)</b>	25.0
<b>Reduced Maximum Output Power Setting (dBm)</b>	22.0

While operating in body-adjacent exposure configurations during a mobile hotspot session, a further reduced maximum power limit is enforced on the CDMA 1900 transmitter (using either 1x during SVLTE, or EVDO for data to the network). A table of the reduced limit used for testing is given below.

<b>Mode(s) of Operation</b>	CDMA 1900
<b>Channel Ranges</b>	25-1175
<b>Maximum Output Power Setting (dBm)</b>	25.0
<b>Reduced Maximum Output Power Setting (dBm)</b>	16.0

See section 6.4 for tables detailing the complete interoperation of this power limit reduction schema.

## 2.3 Device Conducted Power Measurements

### 2.3.1 LTE modes

Measured Conducted Power (dBm) for LTE modes <sup>3</sup>								
Modulation	Channel Bandwidth	RB Allocation Size	RB Offset	Measured Power (dBm)	Power Limit with MPR (dBm)	MPR Target (dB)	Measured reduction from maximum limit	Notes
QPSK	10 MHz	1	0	23.75	24.0	0	0 dB	-
		1	49	23.85	24.0	0	0 dB	-
		50%	12	24.15	23.0	-1	0 dB	-
		100%	0	24.12	23.0	-1	0 dB	-
16QAM	10 MHz	1	0	23.70	23.0	-1	0 dB	-
		1	49	23.80	23.0	-1	0 dB	-
		50%	12	24.13	22.0	-2	0 dB	-
		100%	0	24.12	22.0	-2	0 dB	-

### 2.3.2 CDMA modes

Per the “SAR Measurement Procedures for 3G Devices” released in October, 2007, RC1, RC3 and RC3 (FCH + SCH) CDMA modes, EVDO Rev O, EVDO Rev A were considered. The conducted power measurements (per steps 3, 4 & 10 of section 4.4.5.2 of 3GPP2 C.5.011 / TIA -98-E) for each mode are shown in the table below.

Measured Conducted Power (dBm) for CDMA modes							
		Loopback		Data		EVDO Rev. O	EVDO Rev. A
Band	Channel	RC3 SO55	RC1 SO55	TDSO SO32 + FCH-SCH	TDSO SO32 + SCH	RTAP 153.6k	Subtype 2 RETAP
CDMA 800	1013	25.08	25.11	25.14	25.06	25.11	25.17
	384	25.05	25.07	25.09	25.05	25.09	25.16
	777	24.96	24.98	25.01	24.98	24.98	25.02
CDMA 1900	25	25.03	25.10	25.06	25.05	25.07	25.15
	600	24.97	24.96	24.93	24.93	24.99	25.07
	1175	24.97	25.11	25.01	25.05	25.02	25.10

<sup>3</sup> Due to the device’s design, MPR is only enabled when the device is operating under radiating conditions. Note that this prevents conducted power measurements of this functionality without modification to the unit.

### 2.3.3 Wi-Fi 802.11 modes

Per “SAR Measurement Procedures for 802.11 a/b/g Transmitters” (FCC KDB 248227), power measurements were performed for 802.11 operational modes. The average conducted power measurements for each mode are shown in the tables below. SAR testing for 802.11 was performed with the transmitter set to the lowest data rate on the default test channels **highlighted in bold** in the tables below. Additional testing on higher data rates due to increased conducted power was conducted for the configurations **highlighted in pink**.

Mode	Freq [MHz]	Channel	Conducted Power [dBm]				Detector
			Data Rate [Mbps]				
			1	2	5.5	11	
802.11b	2412	1	<b>17.02</b>	17.11	<b>19.04</b>	19.01	AVG
			19.65	19.76	21.50	21.51	PEAK
802.11b	2437	6	16.18	16.40	18.67	18.78	AVG
			18.73	19.05	21.14	21.16	PEAK
802.11b	2462	11	16.27	16.22	18.45	18.49	AVG
			18.80	18.82	20.87	20.91	PEAK

Mode	Freq [MHz]	Channel	Conducted Power [dBm]								Detector
			Data Rate [Mbps]								
			6	9	12	18	24	36	48	54	
802.11g	2412	1	13.28	13.37	13.30	13.33	13.24	13.26	13.17	13.36	AVG
			19.79	19.71	19.95	19.82	19.49	20.02	19.17	19.68	PEAK
802.11g	2437	6	15.67	16.12	15.90	15.75	15.89	14.74	15.05	13.10	AVG
			21.21	21.52	21.69	21.37	21.58	21.06	20.47	19.53	PEAK
802.11g	2462	11	12.81	12.80	12.78	12.74	12.62	12.65	12.67	12.78	AVG
			19.30	19.21	19.57	19.29	18.99	19.51	19.20	19.13	PEAK
Mode	Freq [MHz]	Channel	Long GI (800 ns) Conducted Power [dBm]								Detector
			Data Rate [Mbps]								
			6.5	13	20	26	39	52	58	65	
802.11n	2412	1	13.31	13.32	13.34	13.14	13.24	13.22	13.21	13.29	AVG
			19.91	19.90	19.87	19.86	19.85	19.64	20.15	19.94	PEAK
802.11n	2437	6	14.90	14.90	14.82	14.23	14.65	13.85	12.91	12.03	AVG
			21.06	20.80	20.85	20.79	20.95	20.22	19.50	18.48	PEAK
802.11n	2462	11	12.87	12.82	12.76	12.58	12.66	12.80	12.73	12.74	AVG
			19.39	19.21	19.29	19.21	19.47	19.20	19.79	19.57	PEAK
Mode	Freq [MHz]	Channel	Short GI (400 ns) Conducted Power [dBm]								Detector
			Data Rate [Mbps]								
			7.2	14.4	21.7	28.9	43.3	57.8	65	72.2	
802.11n	2412	1	13.26	13.27	13.29	13.09	13.19	13.17	13.16	13.24	AVG
			20.33	20.32	20.29	20.28	20.27	20.05	20.58	20.36	PEAK
802.11n	2437	6	14.83	14.83	14.75	14.16	14.58	13.78	12.85	11.97	AVG
			21.20	20.94	20.99	20.93	21.09	20.35	19.63	18.60	PEAK
802.11n	2462	11	12.67	12.62	12.56	12.38	12.46	12.60	12.53	12.54	AVG
			17.74	17.58	17.65	17.58	17.81	17.57	18.11	17.90	PEAK

20 MHz Channel Bandwidth

Mode	Freq [MHz]	Channel	Conducted Power [dBm]								Detector
			Data Rate [Mbps]								
			6	9	12	18	24	36	48	54	
802.11a	5180	36	15.59	14.57	14.59	14.54	14.53	13.38	12.46	11.64	AVG
802.11a	5200	40	15.52	14.45	14.57	14.44	14.51	13.43	12.45	11.68	AVG
802.11a	5220	44	15.53	14.51	14.60	14.55	14.52	13.56	12.47	11.69	AVG
802.11a	5240	48	15.55	14.59	14.54	14.57	14.55	13.54	12.48	11.52	AVG
802.11a	5745	149	15.49	14.63	14.54	14.51	14.62	13.52	12.31	11.48	AVG
			20.38	19.99	20.16	20.02	19.91	19.69	18.68	17.98	PEAK
802.11a	5765	153	15.44	14.49	14.51	14.42	14.71	13.47	12.39	11.37	AVG
			20.36	19.95	20.09	19.97	19.90	19.68	18.74	17.91	PEAK
802.11a	5785	157	15.56	14.72	14.62	14.52	14.73	13.39	12.38	11.57	AVG
			20.34	19.94	20.08	19.95	19.92	19.57	18.77	17.92	PEAK
802.11a	5805	161	15.54	14.67	14.55	14.61	14.69	13.51	12.33	11.67	AVG
			20.27	19.89	20.04	19.89	19.81	19.54	18.67	18.12	PEAK
802.11a	5825	165	15.58	14.67	14.54	14.46	14.67	13.46	12.43	11.54	AVG
			20.22	19.81	19.92	19.79	19.72	19.49	19.69	17.96	PEAK

Mode	Freq [MHz]	Channel	Live GI (800 ns) Conducted Power [dBm]								Detector
			Data Rate [Mbps]								
			6.5	13	20	26	39	52	58	65	
802.11n	5180	36	13.56	13.61	13.52	13.29	13.33	12.52	11.36	10.57	AVG
802.11n	5200	40	13.64	13.62	13.54	13.24	13.48	12.64	11.38	10.53	AVG
802.11n	5220	44	13.72	13.66	13.63	13.39	13.53	12.61	11.43	10.54	AVG
802.11n	5240	48	13.65	13.76	13.56	13.42	13.54	12.60	11.37	10.52	AVG
802.11n	5745	149	13.68	13.57	13.55	13.11	13.43	12.46	11.39	10.36	AVG
			19.62	19.54	19.59	19.38	19.49	18.84	18.61	17.55	PEAK
802.11n	5765	153	13.54	13.56	13.48	13.09	13.41	12.59	11.46	10.51	AVG
			19.53	19.45	19.48	19.37	19.44	18.92	18.56	17.59	PEAK
802.11n	5785	157	13.58	13.57	13.55	13.26	13.37	12.51	11.41	10.38	AVG
			19.47	19.38	19.51	19.43	19.40	18.79	18.57	17.61	PEAK
802.11n	5805	161	13.49	13.52	13.43	13.16	13.34	12.57	11.44	10.39	AVG
			19.41	19.37	19.38	19.35	19.37	18.85	18.47	17.58	PEAK
802.11n	5825	165	13.69	13.63	13.61	13.17	13.47	12.48	11.45	10.40	AVG
			19.45	19.32	19.43	19.21	19.41	18.67	18.49	17.55	PEAK

Mode	Freq [MHz]	Channel	Short GI (400 ns) Conducted Power [dBm]								Detector
			Data Rate [Mbps]								
			7.2	14.4	21.7	28.9	43.3	57.8	65	72.2	
802.11n	5180	36	13.68	13.78	13.73	13.71	13.69	12.53	11.37	10.58	AVG
802.11n	5200	40	13.66	13.74	13.87	13.85	13.86	12.60	11.34	10.49	AVG
802.11n	5220	44	13.75	13.81	13.83	13.84	13.82	12.64	11.46	10.57	AVG
802.11n	5240	48	13.67	13.79	13.77	13.82	13.76	12.53	11.30	10.45	AVG
802.11n	5745	149	13.72	13.63	13.68	13.64	13.61	12.54	11.47	10.44	AVG
			19.59	19.67	19.63	19.64	19.57	18.33	18.10	17.04	PEAK
802.11n	5765	153	13.61	13.57	13.59	13.32	13.48	12.52	11.39	10.44	AVG
			19.57	19.54	19.58	19.51	19.46	18.39	18.03	17.06	PEAK
802.11n	5785	157	13.57	13.52	13.55	13.47	13.51	12.56	11.46	10.43	AVG
			19.53	19.48	19.52	19.54	19.59	18.58	18.36	17.40	PEAK
802.11n	5805	161	13.67	13.65	13.66	13.52	13.55	12.64	11.51	10.46	AVG
			19.50	19.58	19.56	19.84	19.64	18.43	18.05	17.16	PEAK
802.11n	5825	165	13.73	13.71	13.68	13.53	13.59	12.68	11.65	10.60	AVG
			19.42	19.47	19.54	19.45	19.51	18.52	18.34	17.40	PEAK

40 MHz Channel Bandwidth

Mode	Freq [MHz]	Channel	Long GI (800ns - 40MHz) Conducted Power [dBm]								Detector
			Data Rate [Mbps]								
			6.5	13	20	26	39	52	58	65	
802.11n	5190	38	12.88	12.49	12.20	12.05	11.48	10.52	9.47	9.11	AVG
802.11n	5230	46	12.99	12.53	12.45	12.02	11.62	10.51	9.84	9.27	AVG
802.11n	5755	151	12.87	12.36	12.27	12.01	11.23	10.56	9.52	8.91	AVG
			19.40	18.78	18.89	18.71	18.31	17.01	15.96	15.02	PEAK
802.11n	5775	155	12.74	12.31	12.22	12.31	11.40	10.49	9.26	8.87	AVG
			19.09	18.65	18.71	18.68	18.24	16.83	15.82	14.98	PEAK
802.11n	5795	159	12.62	12.47	12.18	11.86	11.31	10.58	9.78	8.97	AVG
			18.96	18.69	18.67	18.41	18.27	16.90	15.90	15.12	PEAK
802.11n	5815	163	12.94	12.67	12.27	12.26	11.39	10.36	9.29	8.91	AVG
			19.15	18.75	18.64	18.56	18.17	16.86	15.94	15.05	PEAK

Mode	Freq	Channel	Short GI (400ns - 40MHz) Conducted Power [dBm]								Detector
			Data Rate [Mbps]								
			7.2	14.4	21.7	28.9	43.3	57.8	65	72.2	
802.11n	5190	38	13.39	12.33	13.09	11.41	12.16	11.51	10.49	10.04	AVG
802.11n	5230	46	13.28	12.29	12.84	11.44	12.02	11.52	10.12	9.88	AVG
802.11n	5755	151	13.16	12.12	12.66	11.43	11.63	11.57	9.80	9.52	AVG
			19.69	18.54	19.28	18.13	18.71	18.02	16.24	15.63	PEAK
802.11n	5775	155	13.03	12.07	12.61	11.73	11.80	11.50	9.54	9.48	AVG
			19.38	18.41	19.10	18.10	18.64	17.84	16.10	15.59	PEAK
802.11n	5795	159	12.91	12.23	12.57	11.28	11.71	11.59	10.06	9.58	AVG
			19.25	18.45	19.06	17.83	18.67	17.91	16.18	15.73	PEAK
802.11n	5815	163	13.23	12.43	12.66	11.68	11.79	11.37	9.57	9.52	AVG
			19.44	18.51	19.03	17.98	18.57	17.87	16.22	15.66	PEAK

### 2.3.4 Bluetooth modes and test exclusion

Frequency [MHz]	Data Rate [Mbps]	Channel Number	Average Conducted Power [mW]
2402	1.0	0	7.261
2441	1.0	39	8.630
2480	1.0	78	6.918
2402	2.0	0	5.224
2441	2.0	39	6.266
2480	2.0	78	4.977
2402	3.0	0	5.236
2441	3.0	39	6.237
2480	3.0	78	5.000

Frequency [MHz]	Mode	Channel Number	Average Conducted Power [mW]
2402	LE	0	6.095
2441	LE	39	7.031
2480	LE	78	5.093

The Bluetooth transmitter of the device under test can be excluded from stand-alone and simultaneous SAR evaluation, per the highlighted requirements from FCC KDB 648474 D01, as follows:

*Vs. Main (Cellular) Antenna*

- The highest output conducted power measured for Bluetooth on the device under test is 8.630 mW [ $\leq 12$  mW]
- The distance between the Bluetooth antenna and the Main (Cellular) antenna is 4.917 cm [ $\geq 2.5$  cm]

*Vs. LTE Antenna*

- The highest output conducted power measured for Bluetooth on the device under test is 8.630 mW [ $\leq 12$  mW]
- The distance between the Bluetooth antenna and the LTE antenna is 4.435 cm [ $\geq 2.5$  cm]

Pictorial representation of the antenna locations and separation distances are given in Exhibit 7d and section 6.4 below.

### 3. Test Equipment Used

#### 3.1 Dosimetric System

The Motorola Mobility ADR Test Services Laboratory utilizes a Dosimetric Assessment System (DASY4™ v4.7 or DASY52™) manufactured by Schmid & Partner Engineering AG (SPEAG™), of Zurich Switzerland. All the SAR measurements are taken within a shielded enclosure. The overall 10 g RSS uncertainty of the measurement system is  $\pm 10.8\%$  ( $K=1$ ) with an expanded uncertainty of  $\pm 21.6\%$  ( $K=2$ ). The overall 1 g RSS uncertainty of the measurement system is  $\pm 11.1\%$  ( $K=1$ ) with an expanded uncertainty of  $\pm 22.2\%$  ( $K=2$ ). The measurement uncertainty budget is given in Appendix 6. Per IEEE 1528, this uncertainty budget is applicable to the SAR range of 0.4 W/kg to 10 W/kg.

The list of calibrated equipment used for measurements is shown in the following tables. All equipment was brought into service and used only during its noted calibration period, except where indicated. Equipment without a calibration period was in service for the entirety of the test period.

Description	Serial Number	Cal Date	Cal Due Date	Service Notes
DASY4™ DAE V1	376	Aug-31-2011	Aug-31-2012	
E-Field Probe ES3DV3	3124	Aug-23-2011	Aug-23-2012	
DASY4™ DAE V1	1310	Jan-11-2012	Jan-11-2013	
E-Field Probe ES3DV3	3284	Jan-10-2012	Jan-10-2013	
DASY4™ DAE V1	1312	May-29-2012	May-29-2013	Removed from service Jul-19-2012
DASY4™ DAE V1	440	May-23-2012	May-23-2013	Placed into service Jul-19-2012
E-Field Probe EX3DV4	3728	Apr-24-2012	Apr-24-2013	
S.A.M. Phantom used for 782/800/900 MHz	TP-1132			
S.A.M. Phantom used for 782/800/900 MHz	TP-1156			
S.A.M. Phantom used for 1800/1900/2450 MHz	TP-1162			
S.A.M. Phantom used for 2.4/5 GHz	TP-1153			
S.A.M. Phantom used for 2.4/5 GHz	TP-1106			
Dipole Validation Kit, DV835V2	4D128	Jan-11-2012	Jan-11-2013	
Dipole Validation Kit, DV835V2	4D129	Jan-11-2012	Jan-11-2013	
Dipole Validation Kit, DV835V2	436TR	Mar-18-2011	Mar-18-2012 <sup>4</sup>	Calibration extension, see footnote.
Dipole Validation Kit, DV1800V2	2D191	Jan-05-2012	Jan-05-2013	
Dipole Validation Kit, DV1800V2	259TR	Oct-20-2011	Oct-20-2012	
Dipole Validation Kit, DV2450V2	877	Jan-10-2012	Jan-10-2013	
Dipole Validation Kit, DV2450V2	863	Mar-17-2011	Mar-17-2012 <sup>4</sup>	Calibration extension, see footnote.
Dipole Validation Kit, D5GHzV2	1088	May-20-2011	May-20-2012 <sup>4</sup>	Calibration extension, see footnote.

#### 3.2 Additional Equipment

Description	Serial Number	Cal Date	Cal Due Date	Service Notes
Signal Generator HP8648C	3847A04810	Sep-26-2011	Sep-26-2013	
Power Meter E4419B	GB39511090	Aug-12-2011	Aug-12-2013	
Power Sensor #1 - E9301A	US39210917	Nov-16-2011	Nov-16-2012	
Power Sensor #2 - E9301A	US39210918	Nov-16-2011	Nov-16-2012	
Signal Generator HP8648C	3847M01245	Aug-23-2011	Aug-23-2013	
Power Meter E4419B	GB39511084	Mar-28-2011	Mar-28-2013	
Power Sensor #1 - E9301A	US39210931	Jan-19-2012	Jan-19-2013	
Power Sensor #2 - E9301A	US39210932	Jan-19-2012	Jan-19-2013	
Signal Generator HP8648C	3847A04632	Aug-13-2011	Aug-13-2013	
Power Meter E4419B	GB39511086	Nov-04-2011	Nov-04-2013	
Power Sensor #1 - E9301A	US39210915	Sep-09-2011	Sep-09-2012	
Power Sensor #2 - E9301A	US39210916	Sep-09-2011	Sep-09-2012	
Signal Generator N5181A	MY50143026	Oct-27-2011	Oct-27-2014	
Power Meter E4419A	GB41293246	Nov-05-2011	Nov-05-2013	
Power Sensor #1 - E9301A	US39211009	Aug-16-2011	Aug-16-2012	
Power Sensor #2 - E9301A	US39211013	Aug-16-2011	Aug-16-2012	
Network Analyzer E5071C	MY46212851	May-10-2012	May-10-2013	Placed into service May-15-2012
Dielectric Probe Kit DAK-3.5	1030			Removed from service Jul-02-2012
Dielectric Probe Kit DAK-3.5	1072			Placed into service Jul-02-2012

<sup>4</sup> Per FCC KDB 450824 D02, evaluation for the extension of the dipole calibration was carried out. Results are provided in Appendix 7 in addition to the original calibration certificate.

#### 4. Electrical parameters of the tissue simulating liquid

Prior to conducting SAR measurements, the relative permittivity,  $\epsilon_r$ , and the conductivity,  $\sigma$ , of the tissue simulating liquids were measured with a HP85070 Dielectric Probe Kit. These values, along with the temperature of the simulated tissue are shown in the table below. The recommended limits for permittivity and conductivity are also shown. A mass density of  $\rho = 1 \text{ g/cm}^3$  was entered into the system in all the cases. It can be seen that the measured parameters are within tolerance of the recommended limits specified in [1] and [5].

E-field probes calibrated at 1810 MHz were used for "1900 MHz" band (1850 MHz - 1910 MHz) SAR measurements. FCC KDB 450824 provides additional requirements on page 3 of 6 for SAR testing that is performed with probe calibration points that are more than 50 MHz removed from the measured bands. The KDB requires; "(2) When nominal tissue dielectric parameters are specified in the probe calibration data, the tissue dielectric parameters measured for routine measurements should be less than the target Er and higher than the target Sigma values to minimize SAR underestimations". The 1900 MHz simulated tissues listed below meet these criteria.

f (MHz)	Tissue type	Limits / Measured	Dielectric Parameters			
			$\epsilon_r$	$\sigma$ (S/m)	Temp (°C)	
782	Head	Measured, Jun-29-2012	41.7	0.89	19.3	
		Recommended Limits	41.78 ±5%	0.896 ±5%	18-25	
	Body	Measured, Jun-30-2012	54.1	0.93	19.2	
		Measured, Jul-06-2012	54.5	0.94	19.1	
			Recommended Limits	55.4 ±5%	0.966 ±5%	18-25
			Measured, Jun-29-2012	41.4	0.94	20.0
835	Head	Measured, Jun-29-2012	41.4	0.94	20.0	
		Recommended Limits	41.5 ±5%	0.90 ±5%	18-25	
	Body	Measured, Jun-27-2012	54.2	0.99	20.0	
		Measured, Jun-29-2012	53.5	1.01	20.0	
			Recommended Limits	55.2 ±5%	0.97 ±5%	18-25
			Measured, Jun-29-2012	38.1	1.45	19.2
1880	Head	Measured, Jul-02-2012	38.7	1.47	19.0	
		Recommended Limits	40.0 ±5%	1.40 ±5%	18-25	
	Body	Measured, Jun-29-2012	51.9	1.59	19.3	
		Measured, Jul-06-2012	51.8	1.57	19.0	
			Recommended Limits	53.3 ±5%	1.52 ±5%	18-25
			Measured, Jul-21-2012	38.4	1.86	19.7
2450	Head	Measured, Jul-21-2012	38.4	1.86	19.7	
		Recommended Limits	39.2 ±5%	1.80 ±5%	18-25	
	Body	Measured, Jul-11-2012	50.4	2.02	19.7	
		Measured, Jul-13-2012	50.3	2.00	19.7	
			Recommended Limits	52.7 ±5%	1.95 ±5%	18-25
			Measured, Jul-11-2012	34.8	4.57	19.7
5210	Head	Measured, Jul-11-2012	34.8	4.57	19.7	
		Recommended Limits	36.0 ±10%	4.66 ±5%	18-25	
	Body	Measured, Jul-11-2012	45.5	5.29	19.7	
		Recommended Limits	49.0 ±10%	5.31 ±5%	18-25	
			Measured, Jul-11-2012	33.9	5.15	20.0
	5785	Head	Measured, Jul-11-2012	33.9	5.15	20.0
Recommended Limits			35.4 ±10%	5.25 ±5%	18-25	
Body		Measured, Jul-12-2012	44.6	6.00	19.5	
		Measured, Jul-14-2012	44.7	6.20	19.2	
		Recommended Limits	48.2 ±10%	5.98 ±5%	18-25	

The list of ingredients and the percent composition used for the simulated tissues are indicated in the table below.

Ingredient	782 / 835 / 900 MHz Head	782 / 835 / 900 MHz Body	1800 MHz / 1900 MHz Head	1800 MHz / 1900 MHz Body	2450 MHz Head	2450 MHz Body	5 GHz Body
Sugar	57	44.9	--	--	--	--	--
DGBE	--	--	47	30.8	6.89	8	--
Diacetin	--	--	--	--	--	--	--
Water	40.45	53.06	52.62	68.8	57.94	71.8	78.66
Salt	1.45	0.94	0.38	0.4	0.15	0.2	--
HEC	1	1	--	--	--	--	--
Bact.	0.1	0.1	--	--	--	--	--
Triton X-100	--	--	--	--	35.02	20	10.67
Di(ethylene glycol) Hexyl Ether	--	--	--	--	--	--	10.67

All 5 GHz Head SAR testing was performed using HBBL3500-5800V5 tissue simulating liquids from Schmid & Partner Engineering AG. Prior to conducting SAR measurements, the relative permittivity,  $\epsilon_r$ , and the conductivity,  $\sigma$ , of the liquids were measured as shown above.

### 5. System Accuracy Verifications

A system accuracy verification of the DASY™ was performed using the measurement equipment listed in Section 3.1. The daily system accuracy verification occurs within the flat section of the SAM phantom.

A SAR measurement was performed to verify the measured SAR was within ±10% from the target SAR indicated in Appendix 7. These frequencies are within ±10% of the compliance test mid-band frequency as required in [1] and [5]<sup>5</sup>. The test was conducted on the same days as the measurement of the DUT. Recommended limits for permittivity and conductivity, specified in [5], are shown in the table below. The obtained results from the system accuracy verification are also displayed in the table below. SAR values are normalized to 1 W forward power delivered to the dipole. It is seen that the system is operating within its specification, as the results are within acceptable tolerance of the reference values. The distributions of SAR compare well with those of the reference measurements (see Appendix 1). For frequencies below 3 GHz, the simulated tissue depth was verified to be 15.0 cm ± 0.5 cm. For frequencies above 3 GHz, the simulated tissue depth was verified to be 10 cm ± 0.5 cm. Z-axis scans showing the SAR penetration are also included in Appendix 1.

System Accuracy Verification Measurements for Head SAR Measurements								
f (MHz)	Description	Dipole	Measured SAR (W/kg), 1 gram	Normalized SAR (W/kg), 1 gram	Dielectric Parameters		Ambient Temp (°C)	Tissue Temp (°C)
					ε <sub>r</sub>	σ (S/m)		
835	Measured, Jun-29-2012	4D129	2.05	10.25	41.4	0.94	20.6	20.0
	Recommended Limits	4D129		9.41	41.5 ±5%	0.90 ±5%	18-25	18-25
	Measured, Jun-30-2012	4D128	2.01	10.05	42.1	0.94	21.0	19.2
	Recommended Limits	4D128		9.45	41.5 ±5%	0.90 ±5%	18-25	18-25
1800	Measured, Jun-29-2012	2D191	7.48	37.40	38.5	1.37	21.0	19.2
	Measured, Jul-02-2012	2D191	7.53	37.65	39.1	1.38	20.7	19.0
	Recommended Limits	2D191		39.2	40.0 ±5%	1.40 ±5%	18-25	18-25
2450	Measured, Jul-21-2012	863	11.5	57.5	38.4	1.86	21.4	19.6
	Recommended Limits	863		54.2	39.2 ±5%	1.80 ±5%	18-25	18-25
5200	Measured, Jul-11-2012	1088	7.50	75.0	34.8	4.56	20.6	20.0
	Recommended Limits	1088		80.2	36.0 ±10%	4.65 ±5%	18-25	18-25
5800	Measured, Jul-11-2012	1088	7.22	72.2	33.9	5.17	21.3	20.1
	Recommended Limits	1088		79.0	35.4 ±10%	5.27 ±5%	18-25	18-25

The following probe conversion factors were used on the E-Field probe(s) used with the system accuracy verification measurements for head SAR measurements:

Description	Serial Number	f (MHz)	Conversion Factor	Cal Cert pg #
E-Field Probe ES3DV3	3124	835	6.08	5 of 11
		1810	5.03	5 of 11
		2450	4.40	5 of 11
E-Field Probe ES3DV3	3284	835	6.18	5 of 11
		1810	5.33	5 of 11
		2450	4.56	5 of 11
E-Field Probe EX3DV4	3728	2450	6.86	5 of 11
		5200	4.74	5 of 11
		5800	4.23	5 of 11

<sup>5</sup> Device testing for LTE Band 13 utilized the same system setup (phantom/probe/tissue) as used for 835 MHz system accuracy verification measurements, and as such those verification measurements are applicable for testing in that transmit band.

System Accuracy Verification Measurements for Body SAR Measurements								
f (MHz)	Description	Dipole	Measured SAR (W/kg), 1 gram	Normalized SAR (W/kg), 1 gram	Dielectric Parameters		Ambient Temp (°C)	Tissue Temp (°C)
					$\epsilon_r$	$\sigma$ (S/m)		
835	Measured, Jun-27-2012	436TR	2.10	10.50	54.2	0.99	20.5	19.8
	Measured, Jun-29-2012	436TR	2.12	10.60	53.5	1.01	21.2	20.6
	Recommended Limits	436TR		10.1	55.2 ±5%	0.97 ±5%	18-25	18-25
	Measured, Jun-30-2012	4D128	2.04	10.20	53.8	0.99	21.0	19.2
	Measured, Jul-06-2012	4D128	2.05	10.25	54.0	0.99	21.2	19.1
	Recommended Limits	4D128		9.45	55.2 ±5%	0.97 ±5%	18-25	18-25
1800	Measured, Jun-29-2012	2D191	7.19	35.95	52.7	1.48	21.1	20.3
	Recommended Limits	2D191		37.8	53.3 ±5%	1.52 ±5%	18-25	18-25
	Measured, Jul-06-2012	259TR	7.67	38.35	52.2	1.48	21.4	19.0
	Recommended Limits	259TR		39.1	53.3 ±5%	1.52 ±5%	18-25	18-25
2450	Measured, Jul-11-2012	877	10.1	50.5	50.4	2.02	20.6	19.4
	Measured, Jul-13-2012	877	10.2	51.0	50.3	2.00	20.1	19.2
	Recommended Limits	877		52.3	52.7 ±5%	1.95 ±5%	18-25	18-25
5200	Measured, Jul-10-2012	1088	7.56	75.6	45.4	5.27	20.3	20.1
	Recommended Limits	1088		75.5	49.03 ±10%	5.30 ±5%	18-25	18-25
5800	Measured, Jul-12-2012	1088	6.91	69.1	44.5	6.03	20.0	19.5
	Measured, Jul-13-2012	1088	7.12	71.2	44.7	6.22	20.6	19.0
	Recommended Limits	1088		75.4	48.2 ±10%	6.00 ±5%	18-25	18-25

The following probe conversion factors were used on the E-Field probe(s) used with the system accuracy verification measurements for body SAR measurements:

Description	Serial Number	f (MHz)	Conversion Factor	Cal Cert pg #
E-Field Probe ES3DV3	3124	835	6.04	6 of 11
		1810	4.69	6 of 11
		2450	4.21	6 of 11
E-Field Probe ES3DV3	3284	835	6.28	6 of 11
		1810	5.28	6 of 11
		2450	4.56	6 of 11
E-Field Probe EX3DV4	3728	2450	6.84	6 of 11
		5200	4.22	6 of 11
		5800	3.71	6 of 11

## **6. Test Results**

For CDMA and LTE modes, the test sample was operated using an actual transmission through a base station simulator. Wi-Fi testing was conducted using manufacturer test mode software, per guidance given in FCC KDB 248227. The base station simulator or test software was set up for the proper channels, transmitter power levels and transmit modes of operation.

The phone was tested in the configurations stipulated in [1], [4] and [5]. The phone was positioned into these configurations using the device holder supplied with the DASYS<sup>TM</sup> SAR measurement system. The default settings for the “coarse” and “cube” scans were chosen and used for measurements. The grid spacing of the coarse scan was set to 15 mm or less as shown in the SAR plots included in Appendices 2 through 4. Please refer to the DASYS<sup>TM</sup> manual for additional information on SAR scanning procedures and algorithms used.

The DUT tested in this report has the following battery options:

Model SNN5916A - 2000 mAH battery

The Model SNN5916A battery is an internally-sealed battery contained within the DUT, and may not be removed by the end-user. This battery was used to do all of the SAR testing. The phone was placed in the SAR measurement system with a fully charged battery.

## 6.1 Head Adjacent Test Results

The SAR results shown in tables 1 through 8 are maximum SAR values averaged over 1 gram of phantom tissue, to demonstrate compliance to [3] and also over 10 grams of phantom tissue, to demonstrate compliance to the [6]. Also shown are the temperatures of the simulated tissue after the test, the measured drift and the extrapolated SAR. The exact method of extrapolation is:

$$\text{Extrapolated SAR} = (\text{Measured SAR}) * 10^{(-\text{drift}/10)}$$

The SAR reported at the end of the measurement process by the DASY™ measurement system can be scaled up by the measured drift to determine the SAR at the beginning of the measurement process. This is the most conservative SAR because it corresponds to the average output power at the beginning of the SAR test. This extrapolation has been done because when the DUT is operating properly it may exhibit a slump in radiated power and SAR over time. This is verified by measuring the SAR drift after the test.

The left head and right head SAR contour distributions are similar. Because of this similarity, the cheek/touch and 15° tilt test conditions with the highest SAR values in each band are indicated as bold numbers in the following tables and are included in Appendix 2. All other test conditions measured lower SAR values than those included in Appendix 2.

The SAR measurements were performed using the SAM phantoms listed in section 3.1. Since the same phantoms and simulated tissue were used for the system accuracy verification and the device SAR measurements, the Z-axis scans included in Appendix 1 are applicable for verification of simulated tissue depth.

The following probe conversion factors were used on the E-Field probe(s) used for head-adjacent measurements:

Description	Serial Number	f (MHz)	Conversion Factor	Cal Cert pg #
E-Field Probe ES3DV3	3124	750	6.26	5 of 11
		835	6.08	5 of 11
		1810	5.03	5 of 11
		2450	4.40	5 of 11
E-Field Probe ES3DV3	3284	835	6.18	5 of 11
		1810	5.33	5 of 11
		2450	4.56	5 of 11
E-Field Probe EX3DV4	3728	2450	6.86	5 of 11
		5200	4.74	5 of 11
		5800	4.23	5 of 11

Left Head Cheek Position																
Band Center Frequency (MHz)	Mode	Battery/Accessory	Channel	DUT Power		Temp (°C)	Drift (dB)	10 g SAR value			1 g SAR value			Test Plot		
				Measured (dBm)	Power Reduction (dB)			Measured (W/kg)	Extrapolated (W/kg)	Corrected (W/kg)	Measured (W/kg)	Extrapolated (W/kg)	Corrected (W/kg)	Grid	Plot Page	
782	LTE Band 13, QPSK (50% RB)	SNN5916A	23230	24.15	-1	19.2	0.02	0.285	0.29	X	0.372	0.37	X			
	LTE Band 13, QPSK (100% RB)	SNN5916A	23230													
	LTE Band 13, QPSK (1 RB @ Low)	SNN5916A	23230	23.75	0	19.2	-0.08	0.316	0.32	X	0.413	0.42	X			
	LTE Band 13, QPSK (1 RB @ High)	SNN5916A	23230	23.85	0	19.2	-0.03	0.338	0.34	X	0.443	0.45	X			
	LTE Band 13, 16QAM (50% RB)	SNN5916A	23230	24.13	-2	18.9	-0.15	0.236	0.24	X	0.312	0.32	X			
	LTE Band 13, 16QAM (100% RB)	SNN5916A	23230													
	LTE Band 13, 16QAM (1 RB @ Low)	SNN5916A	23230	23.70	-1	18.9	0.09	0.265	0.27	X	0.346	0.35	X			
	LTE Band 13, 16QAM (1 RB @ High)	SNN5916A	23230	23.80	-1	18.9	0.01	0.282	0.28	X	0.370	0.37	X			
835	1x CDMA 800, RC3 SO55	SNN5916A	1013													
		SNN5916A	384	25.05	X	20.9	-0.25	0.478	0.51	X	0.633	0.67	X			
		SNN5916A	777													
1880	1x CDMA 1900, RC3 SO55	SNN5916A	25													
		SNN5916A	600	24.97	X	20.0	-0.05	0.284	0.29	X	0.440	0.45	X			
		SNN5916A	1175													
2437	802.11b, 1 Mbps	SNN5916A	1	17.02	X	18.8	0.03	0.172	0.17	X	0.346	0.35	X			
		SNN5916A	6													
		SNN5916A	11													
	802.11b, 5.5 Mbps	SNN5916A	1	19.04	X	19.5	0.02	0.260	0.26	X	0.552	0.55	X			
		SNN5916A	6													
		SNN5916A	11													
5210	802.11a, 6 Mbps	SNN5916A	36	15.59	X	20.1	-0.29	0.077	0.08	X	0.214	0.23	X			
5785	802.11a, 6 Mbps	SNN5916A	165	15.58	X	20.1	-0.63	0.093	0.11	X	0.246	0.28	X			

**Table 1: SAR measurement results at the highest possible output power, measured in a head cheek position against the ICNIRP and ANSI SAR Limit.**

Right Head Cheek Position															
Band Center Frequency (MHz)	Mode	Battery/Accessory	Channel	DUT Power		Temp (°C)	Drift (dB)	10 g SAR value			1 g SAR value			Test Plot	
				Measured (dBm)	Power Reduction (dB)			Measured (W/kg)	Extrapolated (W/kg)	Corrected (W/kg)	Measured (W/kg)	Extrapolated (W/kg)	Corrected (W/kg)	Grid	Plot Page
782	LTE Band 13, QPSK (50% RB)	SNN5916A	23230	24.15	-1	19.3	-0.01	0.323	0.32	X	0.466	0.47	X		
	LTE Band 13, QPSK (100% RB)	SNN5916A	23230							X			X		
	LTE Band 13, QPSK (1 RB @ Low)	SNN5916A	23230	23.75	0	19.0	-0.09	0.350	0.36	X	0.498	0.51	X		
	LTE Band 13, QPSK (1 RB @ High)	SNN5916A	23230	23.85	0	19.0	-0.01	0.375	0.38	X	0.544	0.55	X	6x5x7	A36
	LTE Band 13, 16QAM (50% RB)	SNN5916A	23230	24.13	-2	18.9	-0.08	0.247	0.25	X	0.354	0.36	X		
	LTE Band 13, 16QAM (100% RB)	SNN5916A	23230							X			X		
	LTE Band 13, 16QAM (1 RB @ Low)	SNN5916A	23230	23.70	-1	18.9	0.03	0.276	0.28	X	0.391	0.39	X		
	LTE Band 13, 16QAM (1 RB @ High)	SNN5916A	23230	23.80	-1	18.9	0.05	0.300	0.30	X	0.437	0.44	X		
835	1x CDMA 800, RC3 SO55	SNN5916A	1013							X			X		
		SNN5916A	384	25.05	X	20.8	-0.11	0.508	0.52	X	0.673	0.69	X	5x5x7	A37
		SNN5916A	777							X			X		
1880	1x CDMA 1900, RC3 SO55	SNN5916A	25	25.03	X	20.2	0.16	0.508	0.51	X	0.840	0.84	X		
		SNN5916A	600	24.97	X	20.3	-0.01	0.553	0.55	X	0.923	0.93	X		
		SNN5916A	1175	24.97	X	20.0	0.00	0.765	0.77	X	1.28	1.28	X	5x5x7	A38
2437	802.11b, 1 Mbps	SNN5916A	1	17.02	X	18.7	0.06	0.305	0.31	X	0.671	0.67	X		
		SNN5916A	6	16.18	X	18.8	0.12	0.247	0.25	X	0.545	0.55	X		
		SNN5916A	11	16.27	X	18.8	-0.04	0.218	0.22	X	0.473	0.48	X		
	802.11b, 5.5 Mbps	SNN5916A	1	19.04	X	19.4	-0.07	0.573	0.58	X	1.28	1.30	X	5x5x7	A39
		SNN5916A	6	18.67	X	19.5	-0.01	0.434	0.44	X	0.95	0.95	X		
		SNN5916A	11	18.45	X	19.5	0.06	0.432	0.53	X	0.979	0.98	X		
5210	802.11a, 6 Mbps	SNN5916A	36	15.59	X	20.1	-0.29	0.157	0.17	X	0.497	0.53	X	7x7x6	A40
5785	802.11a, 6 Mbps	SNN5916A	165	15.58	X	20.1	0.03	0.153	0.15	X	0.470	0.47	X	7x7x6	A41

Table 2: SAR measurement results at the highest possible output power, measured in a head cheek position against the ICNIRP and ANSI SAR Limit.

Left Head 15° Tilt Position																
Band Center Frequency (MHz)	Mode	Battery/Accessory	Channel	DUT Power		Temp (°C)	Drift (dB)	10 g SAR value			1 g SAR value			Test Plot		
				Measured (dBm)	Power Reduction (dB)			Measured (W/kg)	Extrapolated (W/kg)	Corrected (W/kg)	Measured (W/kg)	Extrapolated (W/kg)	Corrected (W/kg)	Grid	Plot Page	
782	LTE Band 13, QPSK (50% RB)	SNN5916A	23230	24.15	-1	19.2	0.03	0.205	0.21	X	0.308	0.31	X			
	LTE Band 13, QPSK (100% RB)	SNN5916A	23230													
	LTE Band 13, QPSK (1 RB @ Low)	SNN5916A	23230	23.75	0	19.3	0.05	0.236	0.24	X	0.355	0.36	X			
	LTE Band 13, QPSK (1 RB @ High)	SNN5916A	23230	23.85	0	19.2	-0.13	0.231	0.24	X	0.354	0.36	X			
	LTE Band 13, 16QAM (50% RB)	SNN5916A	23230	24.13	-2	18.9	0.04	0.154	0.15	X	0.245	0.25	X			
	LTE Band 13, 16QAM (100% RB)	SNN5916A	23230													
	LTE Band 13, 16QAM (1 RB @ Low)	SNN5916A	23230	23.70	-1	18.9	0.09	0.179	0.18	X	0.280	0.28	X			
	LTE Band 13, 16QAM (1 RB @ High)	SNN5916A	23230	23.80	-1	18.9	-0.16	0.183	0.19	X	0.287	0.30	X			
835	1x CDMA 800, RC3 SO55	SNN5916A	1013													
		SNN5916A	384	25.05	X	20.8	0.02	0.346	0.35	X	0.456	0.46	X	5x5x7	A43	
		SNN5916A	777													
1880	1x CDMA 1900, RC3 SO55	SNN5916A	25													
		SNN5916A	600	24.97	X	20.3	0.04	0.234	0.23	X	0.407	0.41	X	5x5x7	A44	
		SNN5916A	1175													
2437	802.11b, 1 Mbps	SNN5916A	1	17.02	X	18.8	-0.05	0.060	0.06	X	0.113	0.11	X			
		SNN5916A	6													
		SNN5916A	11													
	802.11b, 5.5 Mbps	SNN5916A	1	19.04	X	19.5	0.08	0.080	0.08	X	0.151	0.15	X			
		SNN5916A	6													
		SNN5916A	11													
5210	802.11a, 6 Mbps	SNN5916A	36	15.59	X	20.1	0.08	0.007	0.01	X	0.026	0.03	X			
5785	802.11a, 6 Mbps	SNN5916A	165	15.58	X	20.1	-0.48	0.013	0.01	X	0.050	0.06	X	7x7x6	A47	

Table 3: SAR measurement results at the highest possible output power, measured in a head tilt position against the ICNIRP and ANSI SAR Limit.

Right Head 15° Tilt Position																
Band Center Frequency (MHz)	Mode	Battery/Accessory	Channel	DUT Power		Temp (°C)	Drift (dB)	10 g SAR value			1 g SAR value			Test Plot		
				Measured (dBm)	Power Reduction (dB)			Measured (W/kg)	Extrapolated (W/kg)	Corrected (W/kg)	Measured (W/kg)	Extrapolated (W/kg)	Corrected (W/kg)	Grid	Plot Page	
782	LTE Band 13, QPSK (50% RB)	SNN5916A	23230	24.15	-1	19.3	0.07	0.222	0.22	X	0.336	0.34	X			
	LTE Band 13, QPSK (100% RB)	SNN5916A	23230													
	LTE Band 13, QPSK (1 RB @ Low)	SNN5916A	23230	23.75	0	19.0	-0.05	0.260	0.26	X	0.391	0.40	X	6x6x7	A42	
	LTE Band 13, QPSK (1 RB @ High)	SNN5916A	23230	23.85	0	19.0	0.05	0.256	0.26	X	0.388	0.39	X			
	LTE Band 13, 16QAM (50% RB)	SNN5916A	23230	24.13	-2	18.9	0.02	0.169	0.17	X	0.263	0.26	X			
	LTE Band 13, 16QAM (100% RB)	SNN5916A	23230													
	LTE Band 13, 16QAM (1 RB @ Low)	SNN5916A	23230	23.70	-1	18.9	-0.09	0.203	0.21	X	0.318	0.32	X			
	LTE Band 13, 16QAM (1 RB @ High)	SNN5916A	23230	23.80	-1	18.9	-0.25	0.198	0.21	X	0.306	0.32	X			
835	1x CDMA 800, RC3 SO55	SNN5916A	1013													
		SNN5916A	384	25.05	X	20.9	0.05	0.342	0.34	X	0.447	0.45	X			
		SNN5916A	777													
1880	1x CDMA 1900, RC3 SO55	SNN5916A	25													
		SNN5916A	600	24.97	X	20.2	0.04	0.211	0.21	X	0.364	0.36	X			
		SNN5916A	1175													
2437	802.11b, 1 Mbps	SNN5916A	1	17.02	X	18.7	-0.07	0.047	0.05	X	0.095	0.10	X			
		SNN5916A	6													
		SNN5916A	11													
	802.11b, 5.5 Mbps	SNN5916A	1	19.04	X	19.4	0.05	0.082	0.08	X	0.169	0.17	X	5x5x7	A45	
		SNN5916A	6													
		SNN5916A	11													
5210	802.11a, 6 Mbps	SNN5916A	36	15.59	X	20.1	-0.15	0.016	0.02	X	0.045	0.05	X	7x7x6	A46	
5785	802.11a, 6 Mbps	SNN5916A	165	15.58	X	20.1	0.66	0.019	0.02	X	0.054	0.05	X			

Table 4: SAR measurement results at the highest possible output power, measured in a head tilt position against the ICNIRP and ANSI SAR Limit.

The measurement data in the following tables is provided to demonstrate SAR performance for the various transmitters operating at reduced power limits, for the purpose of evaluating simultaneous SAR cases. See sections 2.2.2 and 6.4 for further information.

Left Head Cheek Position																
Band Center Frequency (MHz)	Mode	Battery/Accessory	Channel	DUT Power		Temp (°C)	Drift (dB)	10 g SAR value			1 g SAR value			Test Plot		
				Reduced Limit or Measured (dBm)	Power Reduction (dB)			Measured (W/kg)	Extrapolated (W/kg)	Corrected (W/kg)	Measured (W/kg)	Extrapolated (W/kg)	Corrected (W/kg)	Grid	Plot Page	
782	LTE Band 13, QPSK (50% RB)	SNN5916A	23230	17	-7	20.7	-0.15	0.051	0.05	✕	0.069	0.07	✕			
	LTE Band 13, QPSK (100% RB)	SNN5916A	23230													
	LTE Band 13, QPSK (1 RB @ Low)	SNN5916A	23230	17	-7	20.0	0.11	0.044	0.04	✕	0.059	0.06	✕			
	LTE Band 13, QPSK (1 RB @ High)	SNN5916A	23230	17	-7	20.0	0.06	0.050	0.05	✕	0.066	0.07	✕			
	LTE Band 13, 16QAM (50% RB)	SNN5916A	23230	17	-7	20.6	0.04	0.055	0.06	✕	0.073	0.07	✕			
	LTE Band 13, 16QAM (100% RB)	SNN5916A	23230													
	LTE Band 13, 16QAM (1 RB @ Low)	SNN5916A	23230	17	-7	20.2	-0.17	0.049	0.05	✕	0.065	0.07	✕			
	LTE Band 13, 16QAM (1 RB @ High)	SNN5916A	23230	17	-7	20.3	-0.03	0.057	0.06	✕	0.075	0.08	✕			
835	1x CDMA 800, RC3 SO55	SNN5916A	1013													
		SNN5916A	384	18.66	✕	20.8	-0.10	0.115	0.12	✕	0.152	0.16	✕			
		SNN5916A	777													
1880	1x CDMA 1900, RC3 SO55	SNN5916A	25													
		SNN5916A	600	22	-3	19.9	-0.13	0.164	0.17	✕	0.255	0.26	✕			
		SNN5916A	1175													
	1x CDMA 1900, RC3 SO55	SNN5916A	25													
		SNN5916A	600	18.62	✕	19.5	-0.11	0.051	0.05	✕	0.122	0.13	✕			
		SNN5916A	1175													
2437	802.11b, 1 Mbps	SNN5916A	1	12	-6	19.2	0.45	0.063	0.06	✕	0.131	0.13	✕			
		SNN5916A	6													
		SNN5916A	11													
	802.11b, 5.5 Mbps	SNN5916A	1	12	-6	18.6	0.20	0.063	0.06	✕	0.125	0.13	✕			
		SNN5916A	6													
		SNN5916A	11													
5210	802.11a, 6 Mbps	SNN5916A	36	11	-5	20.0	-0.42	0.022	0.02	✕	0.059	0.07	✕			
5785	802.11a, 6 Mbps	SNN5916A	165	11	-5	20.0	-0.59	0.019	0.02	✕	0.057	0.06	✕			

Table 5: SAR measurement results at the highest possible output power, measured in a head cheek position against the ICNIRP and ANSI SAR Limit.

Right Head Cheek Position															
Band Center Frequency (MHz)	Mode	Battery/Accessory	Channel	DUT Power		Temp (°C)	Drift (dB)	10 g SAR value			1 g SAR value			Test Plot	
				Reduced Limit or Measured (dBm)	Power Reduction (dB)			Measured (W/kg)	Extrapolated (W/kg)	Corrected (W/kg)	Measured (W/kg)	Extrapolated (W/kg)	Corrected (W/kg)	Grid	Plot Page
782	LTE Band 13, QPSK (50% RB)	SNN5916A	23230	17	-7	20.3	0.00	0.058	0.06	<del>0.058</del>	0.088	0.09	<del>0.088</del>		
	LTE Band 13, QPSK (100% RB)	SNN5916A	23230												
	LTE Band 13, QPSK (1 RB @ Low)	SNN5916A	23230	17	-7	20.2	-0.26	0.050	0.05	<del>0.050</del>	0.075	0.08	<del>0.075</del>		
	LTE Band 13, QPSK (1 RB @ High)	SNN5916A	23230	17	-7	20.1	0.01	0.057	0.06	<del>0.057</del>	0.087	0.09	<del>0.087</del>		
	LTE Band 13, 16QAM (50% RB)	SNN5916A	23230	17	-7	20.3	0.00	0.059	0.06	<del>0.059</del>	0.087	0.09	<del>0.087</del>		
	LTE Band 13, 16QAM (100% RB)	SNN5916A	23230												
	LTE Band 13, 16QAM (1 RB @ Low)	SNN5916A	23230	17	-7	20.2	0.01	0.046	0.05	<del>0.046</del>	0.067	0.07	<del>0.067</del>		
LTE Band 13, 16QAM (1 RB @ High)	SNN5916A	23230	17	-7	20.2	-0.08	0.055	0.06	<del>0.055</del>	0.081	0.08	<del>0.081</del>			
835	1x CDMA 800, RC3 SO55	SNN5916A	1013												
		SNN5916A	384	18.66	<del>-7</del>	20.9	-0.06	0.123	0.12	<del>0.123</del>	0.163	0.17	<del>0.163</del>		
		SNN5916A	777												
1880	1x CDMA 1900, RC3 SO55	SNN5916A	25												
		SNN5916A	600	22	-3	20.0	0.01	0.333	0.33	<del>0.333</del>	0.560	0.56	<del>0.560</del>		
		SNN5916A	1175												
	1x CDMA 1900, RC3 SO55	SNN5916A	25												
		SNN5916A	600	18.62	<del>-7</del>	19.6	-0.17	0.103	0.11	<del>0.103</del>	0.174	0.18	<del>0.174</del>		
SNN5916A	1175														
2437	802.11b, 1 Mbps	SNN5916A	1	12	-6	19.2	-0.07	0.120	0.12	<del>0.120</del>	0.267	0.27	<del>0.267</del>		
		SNN5916A	6	12	-6	19.2	-0.52	0.090	0.10	<del>0.090</del>	0.208	0.23	<del>0.208</del>		
		SNN5916A	11	12	-6	19.2	0.67	0.091	0.09	<del>0.091</del>	0.213	0.21	<del>0.213</del>		
	802.11b, 5.5 Mbps	SNN5916A	1	12	-6	19.3	0.07	0.109	0.11	<del>0.109</del>	0.246	0.25	<del>0.246</del>		
		SNN5916A	6	12	-6	19.3	0.34	0.114	0.11	<del>0.114</del>	0.260	0.26	<del>0.260</del>		
		SNN5916A	11	12	-6	19.3	0.05	0.094	0.09	<del>0.094</del>	0.214	0.21	<del>0.214</del>		
5210	802.11a, 6 Mbps	SNN5916A	36	11	-5	20.0	-0.63	0.045	0.05	<del>0.045</del>	0.157	0.18	<del>0.157</del>		
5785	802.11a, 6 Mbps	SNN5916A	165	11	-5	20.0	-0.04	0.037	0.04	<del>0.037</del>	0.123	0.12	<del>0.123</del>		

**Table 6: SAR measurement results at the highest possible output power, measured in a head cheek position against the ICNIRP and ANSI SAR Limit.**

Left Head 15° Tilt Position															
Band Center Frequency (MHz)	Mode	Battery/Accessory	Channel	DUT Power		Temp (°C)	Drift (dB)	10 g SAR value			1 g SAR value			Test Plot	
				Reduced Limit or Measured (dBm)	Power Reduction (dB)			Measured (W/kg)	Extrapolated (W/kg)	Corrected (W/kg)	Measured (W/kg)	Extrapolated (W/kg)	Corrected (W/kg)	Grid	Plot Page
782	LTE Band 13, QPSK (50% RB)	SNN5916A	23230	17	-7	20.7	0.17	0.037	0.04	<del>0.04</del>	0.055	0.06	<del>0.06</del>		
	LTE Band 13, QPSK (100% RB)	SNN5916A	23230												
	LTE Band 13, QPSK (1 RB @ Low)	SNN5916A	23230	17	-7	20.1	-0.03	0.031	0.03	<del>0.03</del>	0.045	0.05	<del>0.05</del>		
	LTE Band 13, QPSK (1 RB @ High)	SNN5916A	23230	17	-7	20.2	-0.03	0.034	0.03	<del>0.03</del>	0.053	0.05	<del>0.05</del>		
	LTE Band 13, 16QAM (50% RB)	SNN5916A	23230	17	-7	20.6	0.06	0.038	0.04	<del>0.04</del>	0.056	0.06	<del>0.06</del>		
	LTE Band 13, 16QAM (100% RB)	SNN5916A	23230												
	LTE Band 13, 16QAM (1 RB @ Low)	SNN5916A	23230	17	-7	20.0	0.10	0.036	0.04	<del>0.04</del>	0.053	0.05	<del>0.05</del>		
	LTE Band 13, 16QAM (1 RB @ High)	SNN5916A	23230	17	-7	20.5	0.02	0.037	0.04	<del>0.04</del>	0.056	0.06	<del>0.06</del>		
835	1x CDMA 800, RC3 SO55	SNN5916A	1013												
		SNN5916A	384	18.66	<del>0.00</del>	20.8	0.02	0.084	0.08	<del>0.08</del>	0.111	0.11	<del>0.11</del>		
		SNN5916A	777												
1880	1x CDMA 1900, RC3 SO55	SNN5916A	25												
		SNN5916A	600	22	-3	19.9	-0.09	0.121	0.12	<del>0.12</del>	0.203	0.21	<del>0.21</del>		
		SNN5916A	1175												
	1x CDMA 1900, RC3 SO55	SNN5916A	25												
		SNN5916A	600	18.62	<del>0.00</del>	19.5	0.22	0.030	0.03	<del>0.03</del>	0.052	0.05	<del>0.05</del>		
		SNN5916A	1175												
2437	802.11b, 1 Mbps	SNN5916A	1	12	-6	19.2	0.11	0.016	0.02	<del>0.02</del>	0.032	0.03	<del>0.03</del>		
		SNN5916A	6												
		SNN5916A	11												
	802.11b, 5.5 Mbps	SNN5916A	1	12	-6	18.5	0.11	0.023	0.02	<del>0.02</del>	0.043	0.04	<del>0.04</del>		
		SNN5916A	6												
		SNN5916A	11												
5210	802.11a, 6 Mbps	SNN5916A	36	11	-5	20.0	0.35	0.006	0.01	<del>0.01</del>	0.014	0.01	<del>0.01</del>		
5785	802.11a, 6 Mbps	SNN5916A	165	11	-5	20.0	0.01	0.004	0.00	<del>0.00</del>	0.009	0.01	<del>0.01</del>		

**Table 7: SAR measurement results at the highest possible output power, measured in a head tilt position against the ICNIRP and ANSI SAR Limit.**

Right Head 15° Tilt Position															
Band Center Frequency (MHz)	Mode	Battery/Accessory	Channel	DUT Power		Temp (°C)	Drift (dB)	10 g SAR value			1 g SAR value			Test Plot	
				Reduced Limit or Measured (dBm)	Power Reduction (dB)			Measured (W/kg)	Extrapolated (W/kg)	Corrected (W/kg)	Measured (W/kg)	Extrapolated (W/kg)	Corrected (W/kg)	Grid	Plot Page
782	LTE Band 13, QPSK (50% RB)	SNN5916A	23230	17	-7	20.3	-0.03	0.043	0.04	<del>0.04</del>	0.063	0.06	<del>0.06</del>		
	LTE Band 13, QPSK (100% RB)	SNN5916A	23230												
	LTE Band 13, QPSK (1 RB @ Low)	SNN5916A	23230	17	-7	20.2	-0.02	0.036	0.04	<del>0.04</del>	0.054	0.05	<del>0.05</del>		
	LTE Band 13, QPSK (1 RB @ High)	SNN5916A	23230	17	-7	20.1	-0.09	0.038	0.04	<del>0.04</del>	0.058	0.06	<del>0.06</del>		
	LTE Band 13, 16QAM (50% RB)	SNN5916A	23230	17	-7	20.3	0.04	0.043	0.04	<del>0.04</del>	0.063	0.06	<del>0.06</del>		
	LTE Band 13, 16QAM (100% RB)	SNN5916A	23230												
	LTE Band 13, 16QAM (1 RB @ Low)	SNN5916A	23230	17	-7	20.1	0.04	0.035	0.04	<del>0.04</del>	0.052	0.05	<del>0.05</del>		
	LTE Band 13, 16QAM (1 RB @ High)	SNN5916A	23230	17	-7	20.2	0.08	0.036	0.04	<del>0.04</del>	0.055	0.06	<del>0.06</del>		
835	1x CDMA 800, RC3 SO55	SNN5916A	1013												
		SNN5916A	384	18.66	<del>-3</del>	20.9	0.05	0.084	0.08	<del>0.08</del>	0.110	0.11	<del>0.11</del>		
		SNN5916A	777												
1880	1x CDMA 1900, RC3 SO55	SNN5916A	25												
		SNN5916A	600	22	-3	20.0	0.02	0.121	0.12	<del>0.12</del>	0.196	0.20	<del>0.20</del>		
		SNN5916A	1175												
	1x CDMA 1900, RC3 SO55	SNN5916A	25												
		SNN5916A	600	18.62	<del>-3</del>	19.6	-0.03	0.028	0.03	<del>0.03</del>	0.045	0.05	<del>0.05</del>		
	SNN5916A	1175													
2437	802.11b, 1 Mbps	SNN5916A	1	12	-6	19.2	0.03	0.019	0.02	<del>0.02</del>	0.038	0.04	<del>0.04</del>		
		SNN5916A	6												
		SNN5916A	11												
	802.11b, 5.5 Mbps	SNN5916A	1	12	-6	18.5	-0.04	0.023	0.02	<del>0.02</del>	0.049	0.05	<del>0.05</del>		
		SNN5916A	6												
	SNN5916A	11													
5210	802.11a, 6 Mbps	SNN5916A	36	11	-5	20.2	-0.24	0.004	0.00	<del>0.00</del>	0.012	0.01	<del>0.01</del>		
5785	802.11a, 6 Mbps	SNN5916A	165	11	-5	20.0	0.98	0.004	0.00	<del>0.00</del>	0.011	0.01	<del>0.01</del>		

**Table 8: SAR measurement results at the highest possible output power, measured in a head tilt position against the ICNIRP and ANSI SAR Limit.**

## 6.2 Body-Worn Accessory Test Results

The SAR results shown in tables 9 through 10 are maximum SAR values averaged over 1 gram of phantom tissue, to demonstrate compliance to [3] and also over 10 grams of phantom tissue, to demonstrate compliance to [6]. Also shown is the temperature of the simulated tissue after the test, the measured drift and the extrapolated SAR. The exact method of extrapolation is:

$$\text{Extrapolated SAR} = (\text{Measured SAR}) * 10^{(-\text{drift}/10)}$$

The SAR reported at the end of the measurement process by the DASYS™ measurement system can be scaled up by the measured drift to determine the SAR at the beginning of the measurement process. This is the most conservative SAR because it corresponds to the average output power at the beginning of the SAR test. This extrapolation has been done because when the DUT is operating properly it may exhibit a slump in radiated power and SAR over time. This is verified by measuring the SAR drift after the test.

The test conditions that produced the highest SAR values in each band are indicated as bold numbers in the following tables and are included in Appendix 3. All other test conditions measured lower SAR values than those included in Appendix 3.

A SPEAG™ MFP V5.1 C Triple Modular Phantom was used for the body-worn tests. The triple modular phantom consists of three identical modules that can be installed and removed separately without emptying the liquid. Each module of the triple phantom is constructed of glass-fiber reinforced vinylester (VG-GF) with a thickness at the bottom of 2.0 mm. It measures 29.2 cm(long) by 17.8 cm(wide) by 17.8 cm(tall).

The simulated tissue depth was verified to be 15.0 cm ± 0.5 cm for frequencies less than 3 GHz, or 10.0 cm ± 0.5 cm for frequencies greater than 3 GHz. The same device holder described in section 6 was used for positioning the phone. The cellular phone was tested with a headset connected to the device for all body-worn accessory SAR measurements.

There are no body-worn accessories available for this phone at the time of testing thus the device was tested per the Supplement C testing guidelines for devices that do not have body-worn accessories. A separation distance of 25 mm between the device and the flat phantom was used for testing body-worn SAR. The chosen separation distance of 25 mm is utilized in order to support any case or holder accessories offered or to be offered by Motorola for this product. The device was tested with the front and back of the device facing the phantom. Both sides of the device were tested for the purpose of including the SAR evaluation for body-worn accessories that support the device with the front side facing the user.

The cellular phone was also tested in data mode operations. For these tests, a separation distance of 25 mm between the device and the flat phantom was used. The device was tested in the worst-case SAR position and channel configuration from the voice-mode body-worn testing.

The following probe conversion factors were used on the E-Field probe(s) used for the body-worn measurements:

Description	Serial Number	f (MHz)	Conversion Factor	Cal Cert pg #
E-Field Probe ES3DV3	3124	750	6.09	6 of 11
		835	6.04	6 of 11
		1810	4.69	6 of 11
		2450	4.21	6 of 11
E-Field Probe ES3DV3	3284	835	6.28	6 of 11
		1810	5.28	6 of 11
		2450	4.56	6 of 11
E-Field Probe EX3DV4	3728	2450	6.84	6 of 11
		5200	4.22	6 of 11
		5800	3.71	6 of 11

Body-Worn, Front of Phone 25 mm from Phantom															
Band Center Frequency (MHz)	Mode	Battery/Accessory	Channel	DUT Power		Temp (°C)	Drift (dB)	10 g SAR value			1 g SAR value			Test Plot	
				Measured (dBm)	Power Reduction (dB)			Measured (W/kg)	Extrapolated (W/kg)	Corrected (W/kg)	Measured (W/kg)	Extrapolated (W/kg)	Corrected (W/kg)	Grid	Plot Page
782	LTE Band 13, QPSK (50% RB)	SNN5916A	23230	24.15	-1	19.0	0.00	0.101	0.10	X	0.134	0.13	X		
	LTE Band 13, QPSK (100% RB)	SNN5916A	23230							X			X		
	LTE Band 13, QPSK (1 RB @ Low)	SNN5916A	23230	23.75	0	19.0	0.03	0.121	0.12	X	0.160	0.16	X		
	LTE Band 13, QPSK (1 RB @ High)	SNN5916A	23230	23.85	0	19.0	0.00	0.099	0.10	X	0.132	0.13	X		
	LTE Band 13, 16QAM (50% RB)	SNN5916A	23230	24.13	-2	19.0	0.01	0.096	0.10	X	0.126	0.13	X		
	LTE Band 13, 16QAM (100% RB)	SNN5916A	23230							X			X		
	LTE Band 13, 16QAM (1 RB @ Low)	SNN5916A	23230	23.70	-1	18.8	-0.17	0.088	0.09	X	0.117	0.12	X		
	LTE Band 13, 16QAM (1 RB @ High)	SNN5916A	23230	23.80	-1	18.8	0.00	0.067	0.07	X	0.089	0.09	X		
835	1x CDMA 800, RC3 SO55	SNN5916A	1013							X			X		
		SNN5916A	384	25.05	X	20.4	-0.17	0.438	0.46	X	0.584	0.61	X	5x5x7	A50
		SNN5916A	777							X			X		
1880	1x CDMA 1900, RC3 SO55	SNN5916A	25							X			X		
		SNN5916A	600	24.97	X	20.2	-0.10	0.250	0.26	X	0.413	0.42	X		
		SNN5916A	1175							X			X		
2437	802.11b, 1 Mbps	SNN5916A	1	17.02	X	19.6	0.12	0.009	0.01	X	0.017	0.02	X		
		SNN5916A	6							X			X		
		SNN5916A	11							X			X		
	802.11b, 5.5 Mbps	SNN5916A	1	19.04	X	20.2	0.23	0.014	0.01	X	0.024	0.02	X		
		SNN5916A	6							X			X		
		SNN5916A	11							X			X		
5210	802.11a, 6 Mbps	SNN5916A	36	15.59	X	19.4	-0.10	0.004	0.00	X	0.015	0.02	X		
5785	802.11a, 6 Mbps	SNN5916A	165	15.58	X	19.6	-0.24	0.004	0.00	X	0.018	0.02	X		

Table 9: SAR measurement results at the highest possible output power, measured in a body-worn accessory position against the ICNIRP and ANSI SAR Limit.

Body-Worn, Back of Phone 25 mm from Phantom															
Band Center Frequency (MHz)	Mode	Battery/Accessory	Channel	DUT Power		Temp (°C)	Drift (dB)	10 g SAR value			1 g SAR value			Test Plot	
				Measured (dBm)	Power Reduction (dB)			Measured (W/kg)	Extrapolated (W/kg)	Corrected (W/kg)	Measured (W/kg)	Extrapolated (W/kg)	Corrected (W/kg)	Grid	Plot Page
782	LTE Band 13, QPSK (50% RB)	SNN5916A	23230	24.15	-1	19.0	0.00	0.184	0.18		0.247	0.25			
	LTE Band 13, QPSK (100% RB)	SNN5916A	23230												
	LTE Band 13, QPSK (1 RB @ Low)	SNN5916A	23230	23.75	0	19.0	0.07	0.203	0.20		0.272	0.27		5x5x7	A49
	LTE Band 13, QPSK (1 RB @ High)	SNN5916A	23230	23.85	0	19.0	-0.02	0.182	0.18		0.245	0.25			
	LTE Band 13, 16QAM (50% RB)	SNN5916A	23230	24.13	-2	18.7	0.01	0.138	0.14		0.187	0.19			
	LTE Band 13, 16QAM (100% RB)	SNN5916A	23230												
	LTE Band 13, 16QAM (1 RB @ Low)	SNN5916A	23230	23.70	-1	18.7	-0.06	0.158	0.16		0.214	0.22			
	LTE Band 13, 16QAM (1 RB @ High)	SNN5916A	23230	23.80	-1	18.7	0.05	0.136	0.14		0.186	0.19			
835	1x CDMA 800, RC3 SO55	SNN5916A	1013												
		SNN5916A	384	25.05		20.5	-0.01	0.402	0.40		0.539	0.54			
		SNN5916A	777												
1880	1x CDMA 1900, RC3 SO55	SNN5916A	25												
		SNN5916A	600	24.97		20.2	0.00	0.375	0.38		0.625	0.63		5x5x7	A51
		SNN5916A	1175												
2437	802.11b, 1 Mbps	SNN5916A	1	17.02		19.6	-0.05	0.019	0.02		0.033	0.03			
		SNN5916A	6	16.18		19.6	0.07	0.040	0.04		0.079	0.08		5x5x7	A52
		SNN5916A	11	16.27		19.6	0.30	0.014	0.01		0.027	0.03			
	802.11b, 5.5 Mbps	SNN5916A	1	19.04		20.2	-0.31	0.015	0.02		0.026	0.03			
		SNN5916A	6	18.67		19.5	0.18	0.022	0.02		0.037	0.04			
		SNN5916A	11	18.45		19.5	0.04	0.018	0.02		0.030	0.03			
5210	802.11a, 6 Mbps	SNN5916A	36	15.59		19.4	-0.14	0.033	0.03		0.086	0.09		7x7x6	A53
5785	802.11a, 6 Mbps	SNN5916A	165	15.58		19.7	-0.10	0.038	0.04		0.096	0.10		7x7x6	A54

Table 10: SAR measurement results at the highest possible output power, measured in a body-worn accessory position against the ICNIRP and ANSI SAR Limit.

### 6.3 Mobile Hotspot Test Results

The DUT is capable of functioning as a Wi-Fi to Cellular mobile hotspot. Additional SAR testing was performed according to the test guidelines provided per FCC KDB 941225 D06. Testing was performed with a separation of 1 cm between the DUT and the “flat” phantom. The DUT was positioned for SAR tests with the front and back surfaces facing the phantom, and also with the edges facing the phantom in which the transmitting antenna is less than 2.5 cm from the edge.

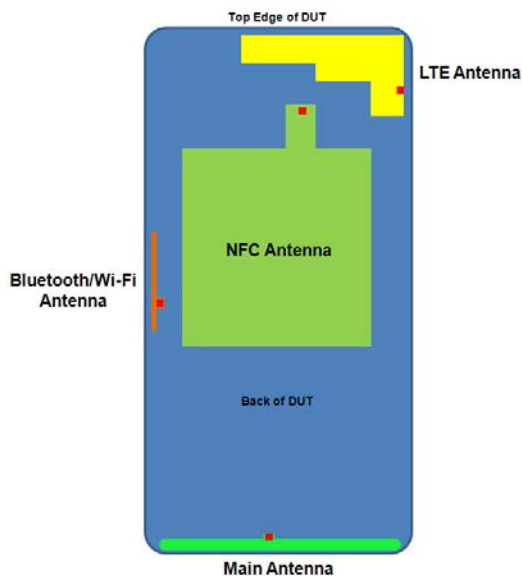

Mobile Hotspot Surfaces for SAR testing						
Mode	Front	Back	Left	Right	Top	Bottom
CDMA	Yes	Yes	Yes	Yes	No	Yes
LTE	Yes	Yes	Yes	Yes	Yes	No
Wi-Fi	Yes	Yes	No	Yes	No	No

The SAR results shown in tables 11 through 16 are maximum SAR values averaged over 1 gram of phantom tissue, to demonstrate compliance to [3] and also over 10 grams of phantom tissue, to demonstrate compliance to [6]. Also shown are the temperature of the simulated tissue after the test, the measured drift and the extrapolated SAR. The exact method of extrapolation is:

$$Extrapolated\ SAR = (Measured\ SAR) * 10^{(-drift/10)}$$

The SAR reported at the end of the measurement process by the DASY™ measurement system can be scaled up by the measured drift to determine the SAR at the beginning of the measurement process. This is the most conservative SAR because it corresponds to the average output power at the beginning of the SAR test. This extrapolation has been done because when the DUT is operating properly it may exhibit a slump in radiated power and SAR over time. This is verified by measuring the SAR drift after the test.

The DUT utilizes reduced limits for the maximum transmit power on several transmitters when the mobile hotspot functionality is enabled, as described above in 2.2.2. A complete description of this functionality is provided in the “Operational Description” contained within Exhibit 12.

When operating as a mobile hotspot, transmission utilizing the 5.2 GHz Wi-Fi band is disabled. The DUT may only operate as a mobile hotspot utilizing the 2.4 GHz or 5.785 GHz Wi-Fi bands.

The test conditions that produced the highest SAR values in each band are indicated as bold numbers in the following tables and are included in Appendix 4. All other test conditions measured lower SAR values than those included in Appendix 4.

A SPEAG™ MFP V5.1 C Triple Modular Phantom was used for the body-worn tests. The triple modular phantom consists of three identical modules that can be installed and removed separately without emptying the liquid. Each module of the triple phantom is constructed of glass-fiber reinforced vinylester (VG-GF) with a thickness at the bottom of 2.0 mm. It measures 29.2 cm(long) by 17.8 cm(wide) by 17.8 cm(tall).

The simulated tissue depth was verified to be 15.0 cm ± 0.5 cm for frequencies below 3 GHz, or 10.0 cm ± 0.5 cm for frequencies greater than 3 GHz. The same device holder described in section 6 was used for positioning the phone.

The following probe conversion factors were used on the E-Field probe(s) used for the body-worn mobile hotspot measurements:

Description	Serial Number	f (MHz)	Conversion Factor	Cal Cert pg #
E-Field Probe ES3DV3	3124	750	6.09	6 of 11
		835	6.04	6 of 11
		1810	4.69	6 of 11
E-Field Probe ES3DV3	3284	835	6.28	6 of 11
		1810	5.28	6 of 11
		2450	4.56	6 of 11
E-Field Probe EX3DV4	3728	5200	4.22	6 of 11
		5800	3.71	6 of 11

Mobile Hotspot, Front of Phone 10 mm from Phantom															
Band Center Frequency (MHz)	Mode	Battery/Accessory	Channel	DUT Power		Temp (°C)	Drift (dB)	10 g SAR value			1 g SAR value			Test Plot	
				Reduced Limit or Measured (dBm)	Power Reduction (dB)			Measured (W/kg)	Extrapolated (W/kg)	Corrected (W/kg)	Measured (W/kg)	Extrapolated (W/kg)	Corrected (W/kg)	Grid	Plot Page
782	LTE Band 13, QPSK (50% RB)	SNN5916A	23230	22	-2	18.9	-0.08	0.181	0.18	<del>0.18</del>	0.235	0.24	<del>0.24</del>		
	LTE Band 13, QPSK (100% RB)	SNN5916A	23230												
	LTE Band 13, QPSK (1 RB @ Low)	SNN5916A	23230	22	-2	19.0	0.04	0.164	0.16	<del>0.16</del>	0.212	0.21	<del>0.21</del>		
	LTE Band 13, QPSK (1 RB @ High)	SNN5916A	23230	22	-2	19.1	-0.04	0.125	0.13	<del>0.13</del>	0.168	0.17	<del>0.17</del>		
	LTE Band 13, 16QAM (50% RB)	SNN5916A	23230	22	-2	19.1	0.08	0.142	0.14	<del>0.14</del>	0.182	0.18	<del>0.18</del>		
	LTE Band 13, 16QAM (100% RB)	SNN5916A	23230												
	LTE Band 13, 16QAM (1 RB @ Low)	SNN5916A	23230	22	-2	19.0	-0.03	0.142	0.14	<del>0.14</del>	0.190	0.19	<del>0.19</del>		
	LTE Band 13, 16QAM (1 RB @ High)	SNN5916A	23230	22	-2	19.0	-0.06	0.115	0.12	<del>0.12</del>	0.156	0.16	<del>0.16</del>		
	LTE Band 13, QPSK (50% RB)	SNN5916A	23230	17	-7	20.6	-0.17	0.029	0.03	<del>0.03</del>	0.045	0.05	<del>0.05</del>		
	LTE Band 13, QPSK (100% RB)	SNN5916A	23230												
	LTE Band 13, QPSK (1 RB @ Low)	SNN5916A	23230	17	-7	20.7	-0.02	0.028	0.03	<del>0.03</del>	0.037	0.04	<del>0.04</del>		
	LTE Band 13, QPSK (1 RB @ High)	SNN5916A	23230	17	-7	20.6	-0.22	0.025	0.03	<del>0.03</del>	0.040	0.04	<del>0.04</del>		
	LTE Band 13, 16QAM (50% RB)	SNN5916A	23230	17	-7	20.6	0.12	0.029	0.03	<del>0.03</del>	0.044	0.04	<del>0.04</del>		
	LTE Band 13, 16QAM (100% RB)	SNN5916A	23230												
LTE Band 13, 16QAM (1 RB @ Low)	SNN5916A	23230	17	-7	20.7	0.18	0.028	0.03	<del>0.03</del>	0.037	0.04	<del>0.04</del>			
LTE Band 13, 16QAM (1 RB @ High)	SNN5916A	23230	17	-7	20.7	0.08	0.023	0.02	<del>0.02</del>	0.038	0.04	<del>0.04</del>			
835	1x CDMA 800, RC3 SO55	SNN5916A	1013	25.08	<del>-6</del>	19.5	-0.05	0.643	0.65	<del>0.65</del>	0.834	0.84	<del>0.84</del>		
		SNN5916A	384	25.05	<del>-6</del>	19.6	-0.25	0.722	0.76	<del>0.76</del>	0.942	1.00	<del>1.00</del>		
		SNN5916A	777	24.96	<del>-6</del>	19.5	0.03	0.796	0.80	<del>0.80</del>	1.04	1.04	<del>1.04</del>	5x5x7	A57
1880	1x CDMA 1900, RC3 SO55	SNN5916A	25												
		SNN5916A	600	16	-9	19.0	-0.03	0.172	0.17	<del>0.17</del>	0.333	0.34	<del>0.34</del>		
		SNN5916A	1175												
2437	802.11b, 1 Mbps	SNN5916A	1	12	-6	19.1	0.00	0.009	0.01	<del>0.01</del>	0.018	0.02	<del>0.02</del>		
		SNN5916A	6	12	-6										
		SNN5916A	11	12	-6										
	802.11b, 5.5 Mbps	SNN5916A	1	12	-6	19.1	0.06	0.011	0.01	<del>0.01</del>	0.023	0.02	<del>0.02</del>		
		SNN5916A	6	12	-6										
		SNN5916A	11	12	-6										
5785	802.11a, 6 Mbps	SNN5916A	165	11	-5	19.6	-0.14	0.004	0.00	<del>0.00</del>	0.012	0.01	<del>0.01</del>		

Table 11: SAR measurement results at the highest possible output power, measured against the ICNIRP and ANSI SAR Limit.

**Mobile Hotspot, Back of Phone 10 mm from Phantom**

Band Center Frequency (MHz)	Mode	Battery/Accessory	Channel	DUT Power		Temp (°C)	Drift (dB)	10 g SAR value			1 g SAR value			Test Plot	
				Reduced Limit or Measured (dBm)	Power Reduction (dB)			Measured (W/kg)	Extrapolated (W/kg)	Corrected (W/kg)	Measured (W/kg)	Extrapolated (W/kg)	Corrected (W/kg)	Grid	Plot Page
782	LTE Band 13, QPSK (50% RB)	SNN5916A	23230	22	-2	19.0	-0.24	0.709	0.75		1.25	1.32		5x5x7	A56
	LTE Band 13, QPSK (100% RB)	SNN5916A	23230												
	LTE Band 13, QPSK (1 RB @ Low)	SNN5916A	23230	22	-2	19.0	0.03	0.656	0.66		1.15	1.15			
	LTE Band 13, QPSK (1 RB @ High)	SNN5916A	23230	22	-2	19.0	-0.03	0.609	0.61		1.09	1.10			
	LTE Band 13, 16QAM (50% RB)	SNN5916A	23230	22	-2	19.0	-0.02	0.563	0.57		0.996	1.00			
	LTE Band 13, 16QAM (100% RB)	SNN5916A	23230												
	LTE Band 13, 16QAM (1 RB @ Low)	SNN5916A	23230	22	-2	19.0	0.00	0.626	0.63		1.09	1.09			
	LTE Band 13, 16QAM (1 RB @ High)	SNN5916A	23230	22	-2	19.0	0.02	0.536	0.54		0.968	0.97			
	LTE Band 13, QPSK (50% RB)	SNN5916A	23230	17	-7	20.7	-0.20	0.134	0.14		0.230	0.24			
	LTE Band 13, QPSK (100% RB)	SNN5916A	23230												
	LTE Band 13, QPSK (1 RB @ Low)	SNN5916A	23230	17	-7	20.6	-0.05	0.125	0.13		0.218	0.22			
	LTE Band 13, QPSK (1 RB @ High)	SNN5916A	23230	17	-7	20.6	-0.06	0.110	0.11		0.199	0.20			
	LTE Band 13, 16QAM (50% RB)	SNN5916A	23230	17	-7	20.7	-0.06	0.131	0.13		0.230	0.23			
	LTE Band 13, 16QAM (100% RB)	SNN5916A	23230												
835	1x CDMA 800, RC3 SO55	SNN5916A	1013	25.08		20.3	-0.21	0.494	0.52		0.664	0.70			
		SNN5916A	384	25.05		19.5	-0.05	0.703	0.71		0.937	0.95			
		SNN5916A	777	24.96		20.3	0.16	0.627	0.63		0.842	0.84			
1880	1x CDMA 1900, RC3 SO55	SNN5916A	25												
		SNN5916A	600	16	-9	19.0	-0.07	0.191	0.19		0.367	0.37			
		SNN5916A	1175												
2437	802.11b, 1 Mbps	SNN5916A	1	12	-6	19.2	-0.08	0.035	0.04		0.073	0.07		5x5x7	A59
		SNN5916A	6	12	-6	19.2	-0.13	0.019	0.02		0.041	0.04			
		SNN5916A	11	12	-6	19.2	-0.02	0.023	0.02		0.048	0.05			
	802.11b, 5.5 Mbps	SNN5916A	1	12	-6	19.1	-0.20	0.033	0.03		0.068	0.07			
		SNN5916A	6	12	-6	19.1	-0.04	0.025	0.03		0.053	0.05			
5785	802.11a, 6 Mbps	SNN5916A	165	11	-5	19.6	-0.09	0.027	0.03		0.096	0.10		7x7x6	A60

**Table 12: SAR measurement results at the highest possible output power, measured against the ICNIRP and ANSI SAR Limit.**

Mobile Hotspot, Left Edge of Phone 10 mm from Phantom															
Band Center Frequency (MHz)	Mode	Battery/Accessory	Channel	DUT Power		Temp (°C)	Drift (dB)	10 g SAR value			1 g SAR value			Test Plot	
				Reduced Limit or Measured (dBm)	Power Reduction (dB)			Measured (W/kg)	Extrapolated (W/kg)	Corrected (W/kg)	Measured (W/kg)	Extrapolated (W/kg)	Corrected (W/kg)	Grid	Plot Page
782	LTE Band 13, QPSK (50% RB)	SNN5916A	23230	22	-2	19.0	-0.14	0.255	0.26	<del>0.26</del>	0.393	0.41	<del>0.41</del>		
	LTE Band 13, QPSK (100% RB)	SNN5916A	23230												
	LTE Band 13, QPSK (1 RB @ Low)	SNN5916A	23230	22	-2	19.0	-0.02	0.210	0.21	<del>0.21</del>	0.323	0.32	<del>0.32</del>		
	LTE Band 13, QPSK (1 RB @ High)	SNN5916A	23230	22	-2	19.0	0.04	0.220	0.22	<del>0.22</del>	0.350	0.35	<del>0.35</del>		
	LTE Band 13, 16QAM (50% RB)	SNN5916A	23230	22	-2	19.0	-0.01	0.209	0.21	<del>0.21</del>	0.320	0.32	<del>0.32</del>		
	LTE Band 13, 16QAM (100% RB)	SNN5916A	23230												
	LTE Band 13, 16QAM (1 RB @ Low)	SNN5916A	23230	22	-2	19.0	-0.18	0.202	0.21	<del>0.21</del>	0.316	0.33	<del>0.33</del>		
	LTE Band 13, 16QAM (1 RB @ High)	SNN5916A	23230	22	-2	19.0	-0.07	0.205	0.21	<del>0.21</del>	0.338	0.34	<del>0.34</del>		
	LTE Band 13, QPSK (50% RB)	SNN5916A	23230	17	-7	20.6	0.01	0.054	0.05	<del>0.05</del>	0.084	0.08	<del>0.08</del>		
	LTE Band 13, QPSK (100% RB)	SNN5916A	23230												
	LTE Band 13, QPSK (1 RB @ Low)	SNN5916A	23230	17	-7	20.6	0.03	0.045	0.05	<del>0.05</del>	0.070	0.07	<del>0.07</del>		
	LTE Band 13, QPSK (1 RB @ High)	SNN5916A	23230	17	-7	20.6	0.10	0.044	0.04	<del>0.04</del>	0.071	0.07	<del>0.07</del>		
	LTE Band 13, 16QAM (50% RB)	SNN5916A	23230	17	-7	20.6	-0.16	0.056	0.06	<del>0.06</del>	0.086	0.09	<del>0.09</del>		
	LTE Band 13, 16QAM (100% RB)	SNN5916A	23230												
	LTE Band 13, 16QAM (1 RB @ Low)	SNN5916A	23230	17	-7	20.6	-0.05	0.049	0.05	<del>0.05</del>	0.076	0.08	<del>0.08</del>		
LTE Band 13, 16QAM (1 RB @ High)	SNN5916A	23230	17	-7	20.6	-0.19	0.044	0.05	<del>0.05</del>	0.069	0.07	<del>0.07</del>			
835	1x CDMA 800, RC3 SO55	SNN5916A	1013	25.08	<del>25.08</del>	20.5	0.01	0.294	0.29	<del>0.29</del>	0.434	0.43	<del>0.43</del>		
		SNN5916A	384	25.05	<del>25.05</del>	19.6	0.01	0.549	0.55	<del>0.55</del>	0.806	0.81	<del>0.81</del>		
		SNN5916A	777	24.96	<del>24.96</del>	20.2	-0.03	0.383	0.39	<del>0.39</del>	0.570	0.57	<del>0.57</del>		
1880	1x CDMA 1900, RC3 SO55	SNN5916A	25												
		SNN5916A	600	16	-9	19.0	-0.08	0.032	0.03	<del>0.03</del>	0.055	0.06	<del>0.06</del>		
		SNN5916A	1175												

Table 13: SAR measurement results at the highest possible output power, measured against the ICNIRP and ANSI SAR Limit.

Mobile Hotspot, Right Edge of Phone 10 mm from Phantom																
Band Center Frequency (MHz)	Mode	Battery/Accessory	Channel	DUT Power		Temp (°C)	Drift (dB)	10 g SAR value			1 g SAR value			Test Plot		
				Reduced Limit or Measured (dBm)	Power Reduction (dB)			Measured (W/kg)	Extrapolated (W/kg)	Corrected (W/kg)	Measured (W/kg)	Extrapolated (W/kg)	Corrected (W/kg)	Grid	Plot Page	
782	LTE Band 13, QPSK (50% RB)	SNN5916A	23230	22	-2	19.0	-0.07	0.171	0.17	<del>0.17</del>	0.246	0.25	<del>0.25</del>			
	LTE Band 13, QPSK (100% RB)	SNN5916A	23230													
	LTE Band 13, QPSK (1 RB @ Low)	SNN5916A	23230	22	-2	19.0	0.01	0.145	0.15	<del>0.15</del>	0.211	0.21	<del>0.21</del>			
	LTE Band 13, QPSK (1 RB @ High)	SNN5916A	23230	22	-2	20.1	0.02	0.119	0.12	<del>0.12</del>	0.172	0.17	<del>0.17</del>			
	LTE Band 13, 16QAM (50% RB)	SNN5916A	23230	22	-2	20.0	0.02	0.135	0.14	<del>0.14</del>	0.194	0.19	<del>0.19</del>			
	LTE Band 13, 16QAM (100% RB)	SNN5916A	23230													
	LTE Band 13, 16QAM (1 RB @ Low)	SNN5916A	23230	22	-2	20.0	0.08	0.138	0.14	<del>0.14</del>	0.202	0.20	<del>0.20</del>			
	LTE Band 13, 16QAM (1 RB @ High)	SNN5916A	23230	22	-2	20.0	0.08	0.111	0.11	<del>0.11</del>	0.160	0.16	<del>0.16</del>			
	LTE Band 13, QPSK (50% RB)	SNN5916A	23230	17	-7	20.5	-0.13	0.031	0.03	<del>0.03</del>	0.045	0.05	<del>0.05</del>			
	LTE Band 13, QPSK (100% RB)	SNN5916A	23230													
	LTE Band 13, QPSK (1 RB @ Low)	SNN5916A	23230	17	-7	20.6	0.05	0.027	0.03	<del>0.03</del>	0.039	0.04	<del>0.04</del>			
	LTE Band 13, QPSK (1 RB @ High)	SNN5916A	23230	17	-7	20.6	0.04	0.022	0.02	<del>0.02</del>	0.033	0.03	<del>0.03</del>			
	LTE Band 13, 16QAM (50% RB)	SNN5916A	23230	17	-7	20.5	0.06	0.030	0.03	<del>0.03</del>	0.044	0.04	<del>0.04</del>			
	LTE Band 13, 16QAM (100% RB)	SNN5916A	23230													
LTE Band 13, 16QAM (1 RB @ Low)	SNN5916A	23230	17	-7	20.6	0.04	0.026	0.03	<del>0.03</del>	0.038	0.04	<del>0.04</del>				
LTE Band 13, 16QAM (1 RB @ High)	SNN5916A	23230	17	-7	20.5	0.06	0.021	0.02	<del>0.02</del>	0.031	0.03	<del>0.03</del>				
835	1x CDMA 800, RC3 SO55	SNN5916A	1013	25.08	<del>-6</del>	20.5	-0.05	0.367	0.37	<del>0.37</del>	0.540	0.55	<del>0.55</del>			
		SNN5916A	384	25.05	<del>-6</del>	19.6	0.07	0.641	0.64	<del>0.64</del>	0.944	0.94	<del>0.94</del>			
		SNN5916A	777	24.96	<del>-6</del>	20.5	-0.04	0.479	0.48	<del>0.48</del>	0.706	0.71	<del>0.71</del>			
1880	1x CDMA 1900, RC3 SO55	SNN5916A	25													
		SNN5916A	600	16	-9	19.0	-0.02	0.042	0.04	<del>0.04</del>	0.074	0.07	<del>0.07</del>			
		SNN5916A	1175													
2437	802.11b, 1 Mbps	SNN5916A	1	12	-6	19.1	0.14	0.010	0.01	<del>0.01</del>	0.019	0.02	<del>0.02</del>			
		SNN5916A	6	12	-6											
		SNN5916A	11	12	-6											
	802.11b, 5.5 Mbps	SNN5916A	1	12	-6	19.1	0.06	0.020	0.02	<del>0.02</del>	0.037	0.04	<del>0.04</del>			
		SNN5916A	6	12	-6											
		SNN5916A	11	12	-6											
5785	802.11a, 6 Mbps	SNN5916A	165	11	-5	19.6	-0.16	0.028	0.03	<del>0.03</del>	0.093	0.10	<del>0.10</del>			

Table 14: SAR measurement results at the highest possible output power, measured against the ICNIRP and ANSI SAR Limit.

Mobile Hotspot, Top Edge of Phone 10 mm from Phantom															
Band Center Frequency (MHz)	Mode	Battery/Accessory	Channel	DUT Power		Temp (°C)	Drift (dB)	10 g SAR value			1 g SAR value			Test Plot	
				Reduced Limit or Measured (dBm)	Power Reduction (dB)			Measured (W/kg)	Extrapolated (W/kg)	Corrected (W/kg)	Measured (W/kg)	Extrapolated (W/kg)	Corrected (W/kg)	Grid	Plot Page
782	LTE Band 13, QPSK (50% RB)	SNN5916A	23230	22	-2	20.6	-0.18	0.092	0.10	<del>0.10</del>	0.152	0.16	<del>0.16</del>		
	LTE Band 13, QPSK (100% RB)	SNN5916A	23230												
	LTE Band 13, QPSK (1 RB @ Low)	SNN5916A	23230	22	-2	20.7	-0.03	0.076	0.08	<del>0.08</del>	0.124	0.12	<del>0.12</del>		
	LTE Band 13, QPSK (1 RB @ High)	SNN5916A	23230	22	-2	20.7	-0.05	0.094	0.09	<del>0.09</del>	0.155	0.16	<del>0.16</del>		
	LTE Band 13, 16QAM (50% RB)	SNN5916A	23230	22	-2	20.6	-0.15	0.090	0.09	<del>0.09</del>	0.148	0.15	<del>0.15</del>		
	LTE Band 13, 16QAM (100% RB)	SNN5916A	23230												
	LTE Band 13, 16QAM (1 RB @ Low)	SNN5916A	23230	22	-2	20.6	-0.02	0.071	0.07	<del>0.07</del>	0.116	0.12	<del>0.12</del>		
	LTE Band 13, 16QAM (1 RB @ High)	SNN5916A	23230	22	-2	20.7	-0.08	0.094	0.10	<del>0.10</del>	0.156	0.16	<del>0.16</del>		
	LTE Band 13, QPSK (50% RB)	SNN5916A	23230	17	-7	20.4	0.00	0.018	0.02	<del>0.02</del>	0.033	0.03	<del>0.03</del>		
	LTE Band 13, QPSK (100% RB)	SNN5916A	23230												
	LTE Band 13, QPSK (1 RB @ Low)	SNN5916A	23230	17	-7	20.4	0.11	0.019	0.02	<del>0.02</del>	0.032	0.03	<del>0.03</del>		
	LTE Band 13, QPSK (1 RB @ High)	SNN5916A	23230	17	-7	20.4	-0.12	0.025	0.03	<del>0.03</del>	0.041	0.04	<del>0.04</del>		
	LTE Band 13, 16QAM (50% RB)	SNN5916A	23230	17	-7	20.4	0.02	0.024	0.02	<del>0.02</del>	0.039	0.04	<del>0.04</del>		
	LTE Band 13, 16QAM (100% RB)	SNN5916A	23230												
LTE Band 13, 16QAM (1 RB @ Low)	SNN5916A	23230	17	-7	20.4	0.02	0.018	0.02	<del>0.02</del>	0.030	0.03	<del>0.03</del>			
LTE Band 13, 16QAM (1 RB @ High)	SNN5916A	23230	17	-7	20.4	0.17	0.021	0.02	<del>0.02</del>	0.034	0.03	<del>0.03</del>			

Table 15: SAR measurement results at the highest possible output power, measured against the ICNIRP and ANSI SAR Limit.

Mobile Hotspot, Bottom Edge of Phone 10 mm from Phantom															
Band Center Frequency (MHz)	Mode	Battery/Accessory	Channel	DUT Power		Temp (°C)	Drift (dB)	10 g SAR value			1 g SAR value			Test Plot	
				Reduced Limit or Measured (dBm)	Power Reduction (dB)			Measured (W/kg)	Extrapolated (W/kg)	Corrected (W/kg)	Measured (W/kg)	Extrapolated (W/kg)	Corrected (W/kg)	Grid	Plot Page
835	1x CDMA 800, RC3 SO55	SNN5916A	1013												
		SNN5916A	384	25.05	<del>25.05</del>	19.5	-0.09	0.049	0.05	<del>0.05</del>	0.087	0.09	<del>0.09</del>		
		SNN5916A	777												
1880	1x CDMA 1900, RC3 SO55	SNN5916A	25	16	-9	19.0	-0.05	0.344	0.35	<del>0.35</del>	0.714	0.72	<del>0.72</del>		
		SNN5916A	600	16	-9	18.9	-0.23	0.430	0.45	<del>0.45</del>	0.893	0.94	<del>0.94</del>		
		SNN5916A	1175	16	-9	19.0	0.11	0.526	0.53	<del>0.53</del>	1.10	1.10	<del>1.10</del>	5x5x7	A58

Table 16: SAR measurement results at the highest possible output power, measured against the ICNIRP and ANSI SAR Limit.

### 6.4 Description and Evaluation of Simultaneous Transmitters

Per "SAR Evaluation Considerations for Handsets with Multiple Transmitters and Antennas" (FCC KDB 648474), the necessity of stand-alone and simultaneous SAR testing was evaluated for the licensed and unlicensed transmitters of the device under test.

By device design the CDMA, LTE, and Wi-Fi transmitters may operate simultaneously as described in the tables on the following pages. CDMA supports both voice and data transmission. LTE and Wi-Fi support data transmission only. Bluetooth may also operate simultaneously with these modes, but is omitted from evaluation as described in section 2.3.4 above. The separation distances between the antennas are depicted in the layout diagram below, and a simplified model of the transmit paths is provided in the block diagram below.

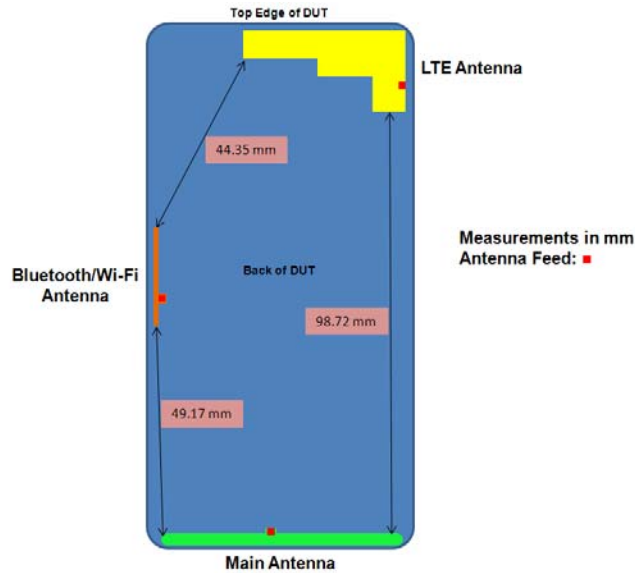

Simplified DUT Transmit Path Block Diagram

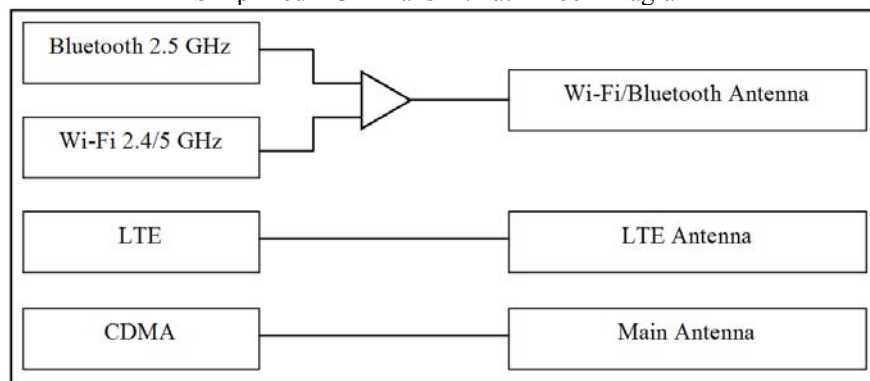

For the transmitters requiring stand-alone SAR testing (CDMA (1x and EVDO), LTE, and Wi-Fi), the KDB guidelines direct that if the sum of the 1 g SAR measured for the simultaneously transmitting antennas is less than the SAR limit, SAR measurement for simultaneous transmission is not required. Further, if the SAR-to-peak-location separation ratio for two simultaneously transmitting antennas is less than 0.3 then SAR measurement for simultaneous transmission is likewise not required. Simultaneous SAR summations for the head, body-worn accessory, and mobile hotspot exposure conditions with the worst-case SAR transmitter configurations are presented in tables 17 to 30 below<sup>6</sup>.

Head Exposure Conditions; Simultaneous Transmit Configurations, including Power Conditions or Reduced Limits							
Case	Transmitter #1		Transmitter #2		Transmitter #3		Notes
	Transmitter Configuration	PWR	Transmitter Configuration	PWR	Transmitter Configuration	PWR	
H1	1x CDMA 800 (Voice)	>18.5	LTE B13 (Data)	17	<del>Wi-Fi 2.4 GHz (Data)</del>	<del>12</del>	SVLTE
H2	1x CDMA 800 (Voice)	≤18.5	LTE B13 (Data)	N/A	<del>Wi-Fi 2.4 GHz (Data)</del>	<del>12</del>	SVLTE
H3	1x CDMA 800 (Voice)	N/A	Wi-Fi 2.4 GHz (Data)	12	<del>Wi-Fi 5.785 GHz (Data)</del>	<del>11</del>	1x Voice + Background Data
H4	1x CDMA 800 (Voice)	N/A	Wi-Fi 5 GHz (Data)	11	<del>Wi-Fi 2.4 GHz (Data)</del>	<del>12</del>	1x Voice + Background Data
H5	1x CDMA 1900 (Voice)	>18.5	LTE B13 (Data)	17	<del>Wi-Fi 2.4 GHz (Data)</del>	<del>12</del>	SVLTE
H6	1x CDMA 1900 (Voice)	≤18.5	LTE B13 (Data)	N/A	<del>Wi-Fi 2.4 GHz (Data)</del>	<del>12</del>	SVLTE
H7	1x CDMA 1900 (Voice)	22	Wi-Fi 2.4 GHz (Data)	12	<del>Wi-Fi 5.785 GHz (Data)</del>	<del>11</del>	1x Voice + Background Data
H8	1x CDMA 1900 (Voice)	22	Wi-Fi 5 GHz (Data)	11	<del>Wi-Fi 2.4 GHz (Data)</del>	<del>12</del>	1x Voice + Background Data
H9	1x CDMA 800 (Voice)	>18.5	LTE B13 (Data)	17	Wi-Fi 2.4 GHz (Data)	12	SVLTE during Mobile Hotspot
H10	1x CDMA 800 (Voice)	≤18.5	LTE B13 (Data)	N/A	Wi-Fi 2.4 GHz (Data)	12	SVLTE during Mobile Hotspot
H11	1x CDMA 800 (Voice)	>18.5	LTE B13 (Data)	17	Wi-Fi 5.785 GHz (Data)	11	SVLTE during Mobile Hotspot
H12	1x CDMA 800 (Voice)	≤18.5	LTE B13 (Data)	N/A	Wi-Fi 5.785 GHz (Data)	11	SVLTE during Mobile Hotspot
H13	1x CDMA 1900 (Voice)	>18.5,22	LTE B13 (Data)	17	Wi-Fi 2.4 GHz (Data)	12	SVLTE during Mobile Hotspot
H14	1x CDMA 1900 (Voice)	≤18.5	LTE B13 (Data)	N/A	Wi-Fi 2.4 GHz (Data)	12	SVLTE during Mobile Hotspot
H15	1x CDMA 1900 (Voice)	>18.5,22	LTE B13 (Data)	17	Wi-Fi 5.785 GHz (Data)	11	SVLTE during Mobile Hotspot
H16	1x CDMA 1900 (Voice)	≤18.5	LTE B13 (Data)	N/A	Wi-Fi 5.785 GHz (Data)	11	SVLTE during Mobile Hotspot

<sup>6</sup> A description of the power conditions or reduced limits for simultaneous transmit modes is provided in section 2.2.2 and in expanded detail in Exhibit 12. The notation used in the “Exposure Condition” tables is as follows for the **PWR** column:

- N/A indicates the transmitter in this case has no reduced power limit enforced and may operate up to its maximum power, and no conditions are contingent on this transmitter’s operation.
- >18.5 and ≤18.5 indicate the transmitter’s power (in dBm) is monitored as a condition for enforcing some other power limit reductions in this case.
- >18.5, 22 indicates that the transmitter’s power (in dBm) is monitored as a condition for enforcing some other power limit reductions in this case, but is also power limited itself to the value noted.
- 22, 17, 16, 12, and 11 indicate an enforced power limit, at the value stated in dBm, on the noted transmitter for this case.

		Transmitter Stand-Alone 1 g SAR Values (W/kg)				1 g SAR Summations (W/kg)		
						Case H1	Case H3	Case H4
Band		CDMA 800	LTE Band 13	Wi-Fi 2.4 GHz	Wi-Fi 5 GHz	CDMA 800 + LTE Band 13	CDMA 800 + Wi-Fi 2.4 GHz	CDMA 800 + Wi-Fi 5 GHz
Power Condition or Reduced Limit		>18.5 or N/A	17 dBm	12 dBm	11 dBm			
Position	Left Head Cheek	0.67	0.08	0.13	0.07	0.75	0.80	0.74
	Left Head 15° Tilt	0.46	0.06	0.04	0.01	0.52	0.50	0.47
	Right Head Cheek	0.69	0.09	0.27	0.18	0.78	0.96	0.87
	Right Head 15° Tilt	0.45	0.06	0.05	0.01	0.51	0.50	0.46

Table 17: SAR summations for simultaneous evaluation – CDMA 800 in Head Positions

		Transmitter Stand-Alone 1 g SAR Values (W/kg)		1 g SAR Summations (W/kg)
				Case H2
Band		CDMA 800	LTE Band 13	CDMA 800 + LTE Band 13
Power Condition or Reduced Limit		≤18.5 dBm	N/A	
Position	Left Head Cheek	0.16	0.45	0.61
	Left Head 15° Tilt	0.11	0.36	0.47
	Right Head Cheek	0.17	0.55	0.72
	Right Head 15° Tilt	0.11	0.40	0.51

Table 18: SAR summations for simultaneous evaluation – CDMA 800 in Head Positions

		Transmitter Stand-Alone 1 g SAR Values (W/kg)					1 g SAR Summations (W/kg)		
							Case H5	Case H7	Case H8
Band		CDMA 1900	CDMA 1900	LTE Band 13	Wi-Fi 2.4 GHz	Wi-Fi 5 GHz	CDMA 1900 + LTE Band 13	CDMA 1900 + Wi-Fi 2.4 GHz	CDMA 1900 + Wi-Fi 5 GHz
Power Condition or Reduced Limit		>18.5 dBm	22 dBm	17 dBm	12 dBm	11 dBm			
Position	Left Head Cheek	0.45	0.26	0.08	0.13	0.07	0.53	0.39	0.33
	Left Head 15° Tilt	0.41	0.21	0.06	0.04	0.01	0.47	0.25	0.22
	Right Head Cheek	1.28	0.56	0.09	0.27	0.18	1.37	0.83	0.74
	Right Head 15° Tilt	0.36	0.20	0.06	0.05	0.01	0.42	0.25	0.21

Table 19: SAR summations for simultaneous evaluation – CDMA 1900 in Head Positions

		Transmitter Stand-Alone 1 g SAR Values (W/kg)		1 g SAR Summations (W/kg)
				Case H6
Band		CDMA 1900	LTE Band 13	CDMA 1900 + LTE Band 13
Power Condition or Reduced Limit		≤18.5 dBm	N/A	
Position	Left Head Cheek	0.13	0.45	0.58
	Left Head 15° Tilt	0.05	0.36	0.41
	Right Head Cheek	0.18	0.55	0.73
	Right Head 15° Tilt	0.05	0.40	0.45

Table 20: SAR summations for simultaneous evaluation – CDMA 1900 in Head Positions

		Transmitter Stand-Alone 1 g SAR Values (W/kg)				1 g SAR Summations (W/kg)	
						Case H9	Case H11
Band	CDMA 800	LTE Band 13	Wi-Fi 2.4 GHz	Wi-Fi 5.785 GHz	CDMA 800 + LTE Band 13 + Wi-Fi 2.4 GHz	CDMA 800 + LTE Band 13 + Wi-Fi 5.785 GHz	
Power Condition or Reduced Limit	>18.5 dBm	17 dBm	12 dBm	11 dBm			
Position	Left Head Cheek	0.67	0.08	0.13	0.06	0.88	0.81
	Left Head 15° Tilt	0.46	0.06	0.04	0.01	0.56	0.53
	Right Head Cheek	0.69	0.09	0.27	0.12	1.05	0.90
	Right Head 15° Tilt	0.45	0.06	0.05	0.01	0.56	0.52

Table 21: SAR summations for simultaneous evaluation – CDMA 800 in Head Positions during a Mobile Hotspot session

		Transmitter Stand-Alone 1 g SAR Values (W/kg)				1 g SAR Summations (W/kg)	
						Case H10	Case H12
Band	CDMA 800	LTE Band 13	Wi-Fi 2.4 GHz	Wi-Fi 5.785 GHz	CDMA 800 + LTE Band 13 + Wi-Fi 2.4 GHz	CDMA 800 + LTE Band 13 + Wi-Fi 5.785 GHz	
Power Condition or Reduced Limit	≤18.5 dBm	N/A	12 dBm	11 dBm			
Position	Left Head Cheek	0.16	0.45	0.13	0.06	0.74	0.67
	Left Head 15° Tilt	0.11	0.36	0.04	0.01	0.51	0.48
	Right Head Cheek	0.17	0.55	0.27	0.12	0.99	0.84
	Right Head 15° Tilt	0.11	0.40	0.05	0.01	0.56	0.52

Table 22: SAR summations for simultaneous evaluation – CDMA 800 in Head Positions during a Mobile Hotspot session

		Transmitter Stand-Alone 1 g SAR Values (W/kg)				1 g SAR Summations (W/kg)	
						Case H13	Case H15
Band	CDMA 1900	LTE Band 13	Wi-Fi 2.4 GHz	Wi-Fi 5.785 GHz	CDMA 1900 + LTE Band 13 + Wi-Fi 2.4 GHz	CDMA 1900 + LTE Band 13 + Wi-Fi 5.785 GHz	
Power Condition or Reduced Limit	>18.5, 22	17 dBm	12 dBm	11 dBm			
Position	Left Head Cheek	0.26	0.08	0.13	0.06	0.47	0.40
	Left Head 15° Tilt	0.21	0.06	0.04	0.01	0.30	0.27
	Right Head Cheek	0.56	0.09	0.27	0.12	0.92	0.77
	Right Head 15° Tilt	0.20	0.06	0.05	0.01	0.31	0.27

Table 23: SAR summations for simultaneous evaluation – CDMA 1900 in Head Positions during a Mobile Hotspot session

		Transmitter Stand-Alone 1 g SAR Values (W/kg)				1 g SAR Summations (W/kg)	
						Case H14	Case H16
Band	CDMA 1900	LTE Band 13	Wi-Fi 2.4 GHz	Wi-Fi 5.785 GHz	CDMA 1900 + LTE Band 13 + Wi-Fi 2.4 GHz	CDMA 1900 + LTE Band 13 + Wi-Fi 5.785 GHz	
Power Condition or Reduced Limit	≤18.5 dBm	N/A	12 dBm	11 dBm			
Position	Left Head Cheek	0.13	0.45	0.13	0.06	0.71	0.64
	Left Head 15° Tilt	0.05	0.36	0.04	0.01	0.45	0.42
	Right Head Cheek	0.18	0.55	0.27	0.12	1.00	0.85
	Right Head 15° Tilt	0.05	0.40	0.05	0.01	0.50	0.46

Table 24: SAR summations for simultaneous evaluation – CDMA 1900 in Head Positions during a Mobile Hotspot session

Body-Worn Accessory Exposure Conditions <sup>7</sup> ; Simultaneous Transmit Configurations, including Power Conditions or Reduced Limits							
Case	Transmitter #1		Transmitter #2		Transmitter #3		Notes
	Transmitter Configuration	PWR	Transmitter Configuration	PWR	Transmitter Configuration	PWR	
B1	1x CDMA 800 (Voice)	>16	LTE B13 (Data)	17			SVLTE
B2	1x CDMA 800 (Voice)	≤16	LTE B13 (Data)	N/A			SVLTE
B3	1x CDMA 800 (Voice)	N/A	Wi-Fi 2.4 GHz (Data)	12			1x Voice + Background Data
B4	1x CDMA 800 (Voice)	N/A	Wi-Fi 5 GHz (Data)	11			1x Voice + Background Data
B5	1x CDMA 1900 (Voice)	>16	LTE B13 (Data)	17			SVLTE
B6	1x CDMA 1900 (Voice)	≤16	LTE B13 (Data)	N/A			SVLTE
B7	1x CDMA 1900 (Voice)	22	Wi-Fi 2.4 GHz (Data)	12			1x Voice + Background Data
B8	1x CDMA 1900 (Voice)	22	Wi-Fi 5 GHz (Data)	11			1x Voice + Background Data

		Transmitter Stand-Alone 1 g SAR Values (W/kg)				1 g SAR Summations (W/kg)		
		CDMA 800	LTE Band 13	Wi-Fi 2.4 GHz	Wi-Fi 5 GHz	CDMA 800 + LTE Band 13	CDMA 800 + Wi-Fi 2.4 GHz	Cases
Band		CDMA 800	LTE Band 13	Wi-Fi 2.4 GHz	Wi-Fi 5 GHz	CDMA 800 + LTE Band 13	CDMA 800 + Wi-Fi 2.4 GHz	CDMA 800 + Wi-Fi 5 GHz
Position	Front of Phone 25 mm from Phantom	0.61	0.16	0.02	0.02	0.77	0.63	0.63
	Back of Phone 25 mm from Phantom	0.54	0.27	0.08	0.10	0.81	0.62	0.64

Table 25: SAR summations for simultaneous evaluation – CDMA 800 in Body-Worn Accessory Positions

		Transmitter Stand-Alone 1 g SAR Values (W/kg)				1 g SAR Summations (W/kg)		
		CDMA 1900	LTE Band 13	Wi-Fi 2.4 GHz	Wi-Fi 5 GHz	Cases		
Band		CDMA 1900	LTE Band 13	Wi-Fi 2.4 GHz	Wi-Fi 5 GHz	1x CDMA 1900 + LTE Band 13	1x CDMA 1900 + Wi-Fi 2.4 GHz	1x CDMA 1900 + Wi-Fi 5 GHz
Position	Front of Phone 25 mm from Phantom	0.42	0.16	0.02	0.02	0.58	0.44	0.44
	Back of Phone 25 mm from Phantom	0.63	0.27	0.08	0.10	0.90	0.71	0.73

Table 26: SAR summations for simultaneous evaluation – CDMA 1900 in Body-Worn Accessory Positions

<sup>7</sup> Note that during typical operation, the power of the transmitters is controlled in the manner described in this table. The summations given in the following tables for the Body-Worn Accessory exposure conditions are shown without power conditions or reduced limits enforced, e.g. all SAR values are for transmitters operating at their maximum power levels. As the SAR summations show results below the compliance limit using values from higher-power configurations than allowed during typical operation, compliance with those reductions employed is implied.

Mobile Hotspot Exposure Conditions; Simultaneous Transmit Configurations, including Power Conditions or Reduced Limits							
Case	Transmitter #1		Transmitter #2		Transmitter #3		Notes
	Transmitter Configuration	PWR	Transmitter Configuration	PWR	Transmitter Configuration	PWR	
M1	CDMA 800 (1x or EVDO)	N/A	Wi-Fi 2.4 GHz (Data)	12			Mobile Hotspot session
M2	CDMA 800 (1x or EVDO)	N/A	Wi-Fi 5.785 GHz (Data)	11			Mobile Hotspot session
M3	CDMA 1900 (1x or EVDO)	16	Wi-Fi 2.4 GHz (Data)	12			Mobile Hotspot session
M4	CDMA 1900 (1x or EVDO)	16	Wi-Fi 5.785 GHz (Data)	11			Mobile Hotspot session
M5	LTE B13 (Data)	22	Wi-Fi 2.4 GHz (Data)	12			Mobile Hotspot session
M6	LTE B13 (Data)	22	Wi-Fi 5.785 GHz (Data)	11			Mobile Hotspot session
M7	1x CDMA 800 (Voice)	N/A	LTE B13 (Data)	17	Wi-Fi 2.4 GHz (Data)	12	SVLTE during Mobile Hotspot
M8	1x CDMA 800 (Voice)	N/A	LTE B13 (Data)	17	Wi-Fi 5.785 GHz (Data)	11	SVLTE during Mobile Hotspot
M9	1x CDMA 1900 (Voice)	16	LTE B13 (Data)	17	Wi-Fi 2.4 GHz (Data)	12	SVLTE during Mobile Hotspot
M10	1x CDMA 1900 (Voice)	16	LTE B13 (Data)	17	Wi-Fi 5.785 GHz (Data)	11	SVLTE during Mobile Hotspot

		Transmitter Stand-Alone 1 g SAR Values (W/kg)				1 g SAR Summations (W/kg)		
		CDMA 800	CDMA 1900	LTE Band 13	Wi-Fi 2.4 GHz	Case M1	Case M3	Case M5
Band						CDMA 800 + Wi-Fi 2.4 GHz	CDMA 1900 + Wi-Fi 2.4 GHz	LTE Band 13 + Wi-Fi 2.4 GHz
Power Condition or Reduced Limit		N/A	16 dBm	22 dBm	12 dBm			
Position	Front of Phone 10 mm from Phantom	1.04	0.34	0.24	0.02	1.06	0.36	0.26
	Back of Phone 10 mm from Phantom	0.95	0.37	1.32	0.07	1.02	0.44	1.39
	Left Edge of Phone 10 mm from Phantom	0.81	0.06	0.41	0	0.81	0.06	0.41
	Right Edge of Phone 10 mm from Phantom	0.94	0.07	0.25	0.04	0.98	0.11	0.29
	Top Edge of Phone 10 mm from Phantom	0	0	0.16	0	0	0	0.16
	Bottom Edge of Phone 10 mm from Phantom	0.09	1.10	0	0	0.09	1.10	0

Table 27: SAR summations for simultaneous evaluation – Positions during a Mobile Hotspot session

		Transmitter Stand-Alone 1 g SAR Values (W/kg)				1 g SAR Summations (W/kg)		
		CDMA 800	CDMA 1900	LTE Band 13	Wi-Fi 5.785 GHz	Case M2	Case M4	Case M6
Band						CDMA 800 + Wi-Fi 5.785 GHz	CDMA 1900 + Wi-Fi 5.785 GHz	LTE Band 13 + Wi-Fi 5.785 GHz
Power Condition or Reduced Limit		N/A	16 dBm	22 dBm	11 dBm			
Position	Front of Phone 10 mm from Phantom	1.04	0.34	0.24	0.01	1.05	0.35	0.25
	Back of Phone 10 mm from Phantom	0.95	0.37	1.32	0.10	1.05	0.47	1.42
	Left Edge of Phone 10 mm from Phantom	0.81	0.06	0.41	0	0.81	0.06	0.41
	Right Edge of Phone 10 mm from Phantom	0.94	0.07	0.25	0.10	1.04	0.17	0.35
	Top Edge of Phone 10 mm from Phantom	0	0	0.16	0	0	0	0.16
	Bottom Edge of Phone 10 mm from Phantom	0.09	1.10	0	0	0.09	1.10	0

Table 28: SAR summations for simultaneous evaluation – Positions during a Mobile Hotspot session

		Transmitter Stand-Alone 1 g SAR Values (W/kg)				1 g SAR Summations (W/kg)	
		CDMA 800	LTE Band 13	Wi-Fi 2.4 GHz	Wi-Fi 5.785 GHz	Case M7	Case M8
Band		CDMA 800	LTE Band 13	Wi-Fi 2.4 GHz	Wi-Fi 5.785 GHz	CDMA 800 + LTE Band 13 + Wi-Fi 2.4 GHz	CDMA 800 + LTE Band 13 + Wi-Fi 5.785 GHz
Power Condition or Reduced Limit		N/A	17 dBm	12 dBm	11 dBm		
Position	Front of Phone 10 mm from Phantom	1.04	0.05	0.02	0.01	1.11	1.10
	Back of Phone 10 mm from Phantom	0.95	0.24	0.07	0.10	1.26	1.29
	Left Edge of Phone 10 mm from Phantom	0.81	0.09	0	0	0.90	0.90
	Right Edge of Phone 10 mm from Phantom	0.94	0.05	0.04	0.10	1.03	1.09
	Top Edge of Phone 10 mm from Phantom	0	0.04	0	0	0.04	0.04
	Bottom Edge of Phone 10 mm from Phantom	0.09	0	0	0	0.09	0.09

Table 29: SAR summations for simultaneous evaluation – Positions during a Mobile Hotspot session with a concurrent Voice session

		Transmitter Stand-Alone 1 g SAR Values (W/kg)				1 g SAR Summations (W/kg)	
		CDMA 1900	LTE Band 13	Wi-Fi 2.4 GHz	Wi-Fi 5.785 GHz	Case M9	Case M10
Band		CDMA 1900	LTE Band 13	Wi-Fi 2.4 GHz	Wi-Fi 5.785 GHz	CDMA 1900 + LTE Band 13 + Wi-Fi 2.4 GHz	CDMA 1900 + LTE Band 13 + Wi-Fi 5.785 GHz
Power Condition or Reduced Limit		16 dBm	17 dBm	12 dBm	11 dBm		
Position	Front of Phone 10 mm from Phantom	0.34	0.05	0.02	0.01	0.41	0.40
	Back of Phone 10 mm from Phantom	0.37	0.24	0.07	0.10	0.68	0.71
	Left Edge of Phone 10 mm from Phantom	0.06	0.09	0	0	0.15	0.15
	Right Edge of Phone 10 mm from Phantom	0.07	0.05	0.04	0.10	0.16	0.22
	Top Edge of Phone 10 mm from Phantom	0	0.04	0	0	0.04	0.04
	Bottom Edge of Phone 10 mm from Phantom	1.10	0	0	0	1.10	1.10

Table 30: SAR summations for simultaneous evaluation – Positions during a Mobile Hotspot session with a concurrent Voice session

**Simultaneous Evaluation Conclusion**

As no summation of transmitter SAR values results in a value greater than the compliance limit, no measurements for simultaneous SAR are required.

## References

- [1] CENELEC, en62209-1:2006 “Human Exposure to Radio Frequency Fields From Hand - Held and Body - Mounted Wireless Communication Devices – Human Models, Instrumentation, and Procedures”
- [2] CENELEC, en50360:2001 “Product standard to demonstrate the compliance of mobile phones with the basic restrictions related to human exposure to electromagnetic fields (300 MHz – 3 GHz)”.
- [3] ANSI / IEEE, C95.1 1992 Edition “IEEE Standard for Safety Levels with Respect to Human Exposure to Radio Frequency Electromagnetic Fields, 3 kHz to 300 GHz”
- [4] FCC OET Bulletin 65 Supplement C 01-01
- [5] IEEE 1528 2003 Edition “IEEE Recommended Practice for Determining the Peak Spatial-Average Specific Absorption Rate (SAR) in the Human Head from Wireless Communications Devices: Measurement Techniques”
- [6] ICNIRP Guidelines “Guidelines for Limiting Exposure to Time-Varying Electric, Magnetic, and Electromagnetic Fields (up to 300 GHz)”