

# FCC RF Test Report

APPLICANT : Motorola Mobility, Inc.  
EQUIPMENT : CDMA Mobile Phone with BT/Wifi  
BRAND NAME : Motorola  
MODEL NAME /  
MARKETING NAME : XT555C  
GPPD NUMBER : 3339  
FCC ID : IHDT56NC3  
STANDARD : FCC 47 CFR Part 2, 24(E)  
CLASSIFICATION : PCS Licensed Transmitter Held to Ear (PCE)  
Tx/Rx FREQUENCY RANGE : CDMA2000 BC1 :1851.25 ~ 1908.75 MHz /  
1931.25 ~ 1988.75 MHz  
MAX. ERP/EIRP POWER : CDMA2000 BC1 : 0.4436 W

The product was received on Mar. 07, 2012 and completely tested on Apr. 11, 2012. We, SPORTON INTERNATIONAL INC., would like to declare that the tested sample has been evaluated in accordance with the procedures given in ANSI / TIA / EIA-603-C-2004 and shown compliance with the applicable technical standards.

The test results in this report apply exclusively to the tested model / sample. Without written approval of SPORTON INTERNATIONAL INC., the test report shall not be reproduced except in full.

Reviewed by:



Jones Tsai / Manager



## SPORTON INTERNATIONAL INC.

No. 52, Hwa Ya 1<sup>st</sup> Rd., Hwa Ya Technology Park, Kwei-Shan Hsiang, Tao Yuan Hsien, Taiwan, R.O.C.



# TABLE OF CONTENTS

**REVISION HISTORY..... 3**

**SUMMARY OF TEST RESULT ..... 4**

**1 GENERAL DESCRIPTION ..... 5**

    1.1 Applicant..... 5

    1.2 Manufacturer ..... 5

    1.3 Feature of Equipment Under Test..... 5

    1.4 Emission Designator ..... 5

    1.5 Testing Site ..... 6

    1.6 Applied Standards ..... 6

    1.7 Ancillary Equipment List..... 6

**2 TEST CONFIGURATION OF EQUIPMENT UNDER TEST ..... 7**

    2.1 Test Mode..... 7

    2.2 Connection Diagram of Test System ..... 8

**3 TEST RESULT..... 9**

    3.1 Conducted Output Power Measurement..... 9

    3.2 Effective Isotropic Radiated Power Measurement ..... 10

    3.3 Occupied Bandwidth Measurement ..... 12

    3.4 Band Edge Measurement..... 16

    3.5 Conducted Emission Measurement ..... 19

    3.6 Field Strength of Spurious Radiation Measurement ..... 23

    3.7 Frequency Stability Measurement..... 27

**4 LIST OF MEASURING EQUIPMENT ..... 30**

**5 UNCERTAINTY OF EVALUATION ..... 31**





### SUMMARY OF TEST RESULT

Report Section	FCC Rule	IC Rule	Description	Limit	Result	Remark
3.1	§2.1046	N/A	Conducted Output Power	N/A	PASS	-
3.2	§24.232(c)	RSS-133 (6.4) SRSP-510(5.1.2)	Equivalent Isotropic Radiated Power	< 2 Watts	PASS	-
3.3	§2.1049 §24.238(a)	N/A	Occupied Bandwidth	N/A	PASS	-
3.4	§2.1051 §24.238(a)	RSS-133 (6.5.1)	Band Edge Measurement	< 43+10log <sub>10</sub> (P[Watts])	PASS	-
3.5	§2.1051 §24.238(a)	RSS-133 (6.5.1)	Conducted Emission	< 43+10log <sub>10</sub> (P[Watts])	PASS	-
3.6	§2.1053 §24.238(a)	RSS-133 (6.5.1)	Field Strength of Spurious Radiation	< 43+10log <sub>10</sub> (P[Watts])	PASS	Under limit 28.43 dB at 3760.000 MHz
3.7	§2.1055 §24.235	RSS-133(6.3)	Frequency Stability for Temperature & Voltage	< 2.5 ppm	PASS	-



# 1 General Description

## 1.1 Applicant

Motorola Mobility, Inc.

No. 1, Wang Jing East Road, Chao Yang District, 100102 Beijing, P. R. China

## 1.2 Manufacturer

Foxconn (TianJin) Precision Industry Co., Ltd.

No. 207, Nanhai Road, TEDA, Tianjin, P.R. China, 300457

## 1.3 Feature of Equipment Under Test

Product Feature & Specification	
Equipment	CDMA Mobile Phone with BT/Wifi
Brand Name	Motorola
Model Name / Market Name	XT555C
FCC ID	IHDT56NC3
Tx Frequency	1850 MHz ~1910 MHz
Rx Frequency	1930 MHz ~ 1990 MHz
Maximum Output Power to Antenna	24.20 dBm
Antenna Type	Monopole Antenna
HW Version	PR3
SW Version	1.53C
Type of Modulation	QPSK
EUT Stage	Identical Prototype

Remark: The above EUT's information was declared by manufacturer. Please refer to the specifications or user's manual for more detailed description.

## 1.4 Emission Designator

FCC Rule	System	Type of Modulation	Emission Designator	Maximum ERP/EIRP
Part 24	CDMA2000 BC1 1xRTT	QPSK	1M28F9W	0.4436 W



### 1.5 Testing Site

<b>Test Site</b>	SPORTON INTERNATIONAL (KUNSHAN) INC.		
<b>Test Site Location</b>	No. 3-2, PingXiang Road, Kunshan, Jiangsu Province, P.R.C. TEL: +86-0512-5790-0158 FAX: +86-0512-5790-0958		
<b>Test Site No.</b>	<b>Sporton Site No.</b>		<b>FCC/IC Registration No.</b>
	TH01-KS	03CH01-KS	149928/4086E-1

### 1.6 Applied Standards

According to the specifications of the manufacturer, the EUT must comply with the requirements of the following standards:

- Preliminary Guidance for Receiving Applications for Certification of 3G Device. May 9, 2006.
- FCC 47 CFR Part 2, 24(E)
- ANSI / TIA / EIA-603-C-2004
- FCC KDB 971168 D01 Power Meas. License Digital Systems v01
- IC RSS-133 Issue 5

**Remark:**

1. All test items were verified and recorded according to the standards and without any deviation during the test.
2. This EUT has also been tested and complied with the requirements of FCC Part 15, Subpart B, recorded in a separate test report.

### 1.7 Ancillary Equipment List

Item	Equipment	Trade Name	Model No.	FCC ID	Data Cable	Power Cord
1.	System Simulator	R&S	CMU 200	N/A	N/A	Unshielded, 1.8 m
2.	DC Power Supply	GW	GPS-30300	N/A	N/A	Unshielded, 1.8 m

## 2 Test Configuration of Equipment Under Test

### 2.1 Test Mode

During all testing, EUT is in link mode with base station emulator at maximum power level. The spurious emission measurements were carried out in semi-anechoic chamber with 3-meter test range, and EUT is rotated on three test planes to find out the worst emission.

Frequency range investigated for radiated emission is as follows:

1. 30 MHz to 19000 MHz for CDMA2000 BC1.

Test Modes		
Band	Radiated TCs	Conducted TCs
CDMA2000 BC1	■ 1xRTT Link Mode	■ 1xRTT Link Mode

**Note:** The maximum RF output power levels is 1xRTT RC3+SO32 mode for CDMA2000 BC1 on QPSK Link; only these modes were used for all tests.

The conducted power table is as follows:

Conducted Power (*Unit: dBm)			
Band	CDMA2000 BC1		
Channel	25	600	1175
Frequency	1851.25	1880	1908.75
1xRTT RC1+SO55	24.16	23.89	24.13
1xRTT RC3+SO55	24.19	23.91	23.82
1xRTT RC3+SO32(+ F-SCH)	24.20	23.88	23.85
1xRTT RC3+SO32(+SCH)	24.19	23.93	23.84
1xEVDO RTAP 153.6K	24.18	23.82	24.05
1xEVDO RETAP 4096K	24.20	23.96	23.99

## 2.2 Connection Diagram of Test System

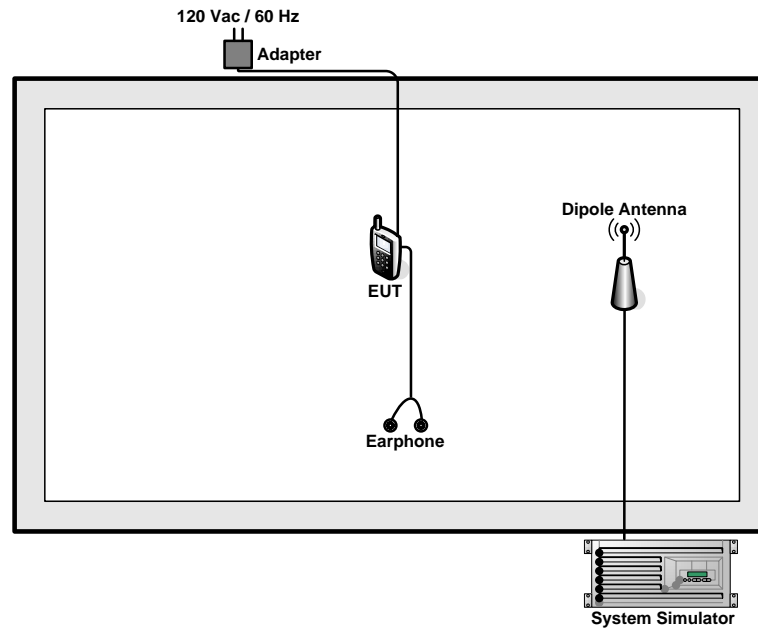

### 3 Test Result

#### 3.1 Conducted Output Power Measurement

##### 3.1.1 Description of the Conducted Output Power Measurement

A base station simulator was used to establish communication with the EUT. Its parameters were set to transmit the maximum power on the EUT. The measured power in the radio frequency on the transmitter output terminals shall be reported.

##### 3.1.2 Measuring Instruments

See list of measuring instruments of this test report.

##### 3.1.3 Test Procedures

1. The transmitter output port was connected to base station.
2. Set EUT at maximum power through base station.
3. Select lowest, middle, and highest channels for each band and different modulation.

##### 3.1.4 Test Setup

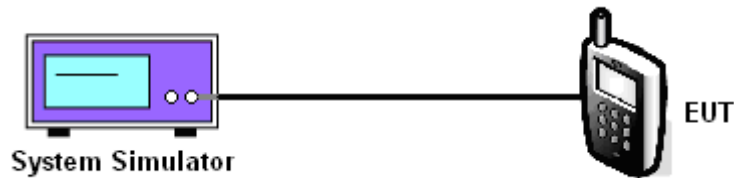

##### 3.1.5 Test Result of Conducted Output Power

CDMA2000 BC1			
Test Mode	CDMA 2000 1xRTT		
Test Status	RC3+SO32		
Channel	25 (Low)	600 (Mid)	1175 (High)
Frequency (MHz)	1851.25	1880	1908.75
Conducted Power (dBm)	24.20	23.88	23.85
Conducted Power (Watts)	0.26	0.25	0.26

## 3.2 Effective Isotropic Radiated Power Measurement

### 3.2.1 Description of the EIRP Measurement

The substitution method, in ANSI / TIA / EIA-603-C-2004, was used for EIRP measurement, and the spectrum analyzer configuration follows KDB 971168 D01 Power Meas. License Digital Systems v01. The EIRP of mobile transmitters are limited to 2 Watts.

### 3.2.2 Measuring Instruments

See list of measuring instruments of this test report.

### 3.2.3 Test Procedures

1. The EUT was placed on a turntable with 1.0 meter height in a fully anechoic chamber.
2. The EUT was set at 1.2 meters from the receiving antenna, which was mounted on the antenna tower.
3. The table was rotated 360 degrees to determine the position of the highest radiated power.
4. The height of the receiving antenna is adjusted to look for the maximum EIRP.
5. Taking the record of maximum EIRP.
6. A dipole antenna was substituted in place of the EUT and was driven by a signal generator.
7. The conducted power at the terminal of the dipole antenna is measured.
8. Repeat step 3 to step 5 to get the maximum ERP/EIRP of the substitution antenna.
9.  $ERP/EIRP = P_s + E_t - E_s + G_s = P_s + R_t - R_s + G_s$

$P_s$  (dBm) : Input power to substitution antenna.

$G_s$  (dBi or dBd) : Substitution antenna Gain.

$E_t = R_t + AF$

$E_s = R_s + AF$

$AF$  (dB/m) : Receive antenna factor

$R_t$  : The highest received signal in spectrum analyzer for EUT.

$R_s$  : The highest received signal in spectrum analyzer for substitution antenna.

### 3.2.4 Test Setup

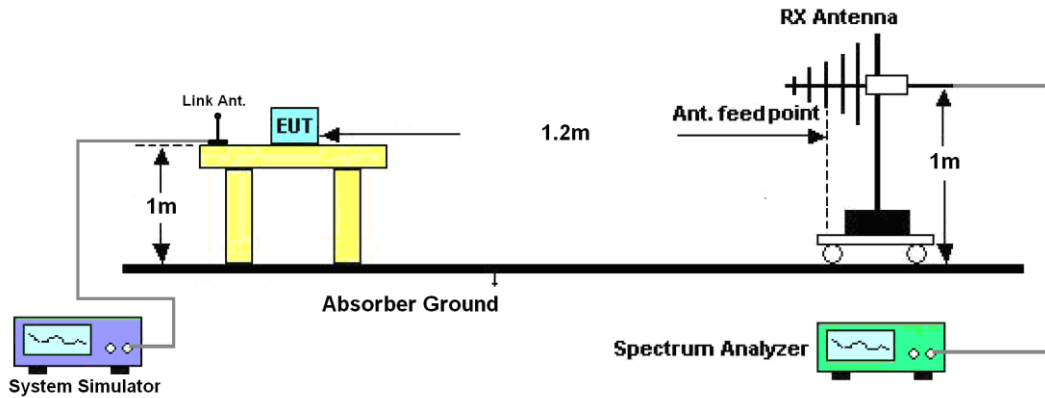

### 3.2.5 Test Result of EIRP

CDMA2000 BC1 1xRTT_RC3+SO32 Radiated Power EIRP						
Horizontal Polarization						
Frequency (MHz)	Rt (dBm)	Rs (dBm)	Ps (dBm)	Gs (dBi)	EIRP (dBm)	EIRP (W)
1851.25	-28.56	-51.88	0.00	1.96	25.28	0.3373
1880.00	-28.52	-52.99	0.00	2.00	26.47	0.4436
1908.75	-30.01	-54.28	0.00	1.98	26.25	0.4217
Vertical Polarization						
Frequency (MHz)	Rt (dBm)	Rs (dBm)	Ps (dBm)	Gs (dBi)	EIRP (dBm)	EIRP (W)
1851.25	-29.20	-52.13	0.00	1.96	24.89	0.3083
1880.00	-29.34	-53.17	0.00	2.00	25.83	0.3828
1908.75	-30.32	-54.13	0.00	1.98	25.79	0.3793

### 3.3 Occupied Bandwidth Measurement

#### 3.3.1 Description of Occupied Bandwidth Measurement

The emission bandwidth is defined as the width of the signal between two points, located at the 2 sides of the carrier frequency, outside of which all emissions are attenuated at least 26 dB below the transmitter power.

#### 3.3.2 Measuring Instruments

See list of measuring instruments of this test report.

#### 3.3.3 Test Procedures

1. The EUT was connected to Spectrum Analyzer and Base Station via power divider.
2. The 99% and 26 dB occupied bandwidth (BW) of the middle channel for the highest RF powers were measured.

#### 3.3.4 Test Setup

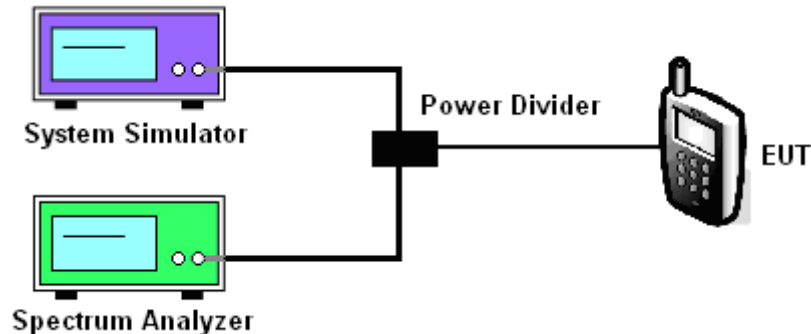



### 3.3.5 Test Result (Plots) of Occupied Bandwidth

<b>Band :</b>	CDMA2000 BC1	<b>Power Stage :</b>	High
<b>Test Mode :</b>	1xRTT_RC3+SO32		

99% Occupied Bandwidth Plot on Channel 25

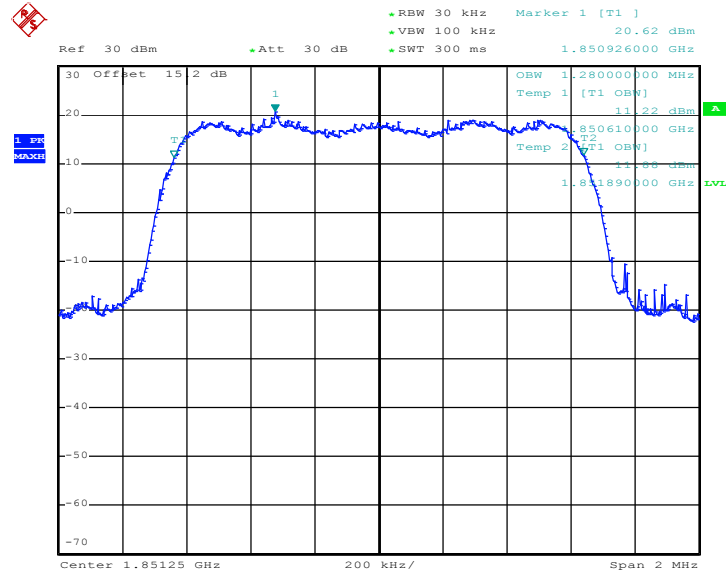

Date: 22.MAR.2012 14:13:10

26dB Bandwidth Plot on Channel 25

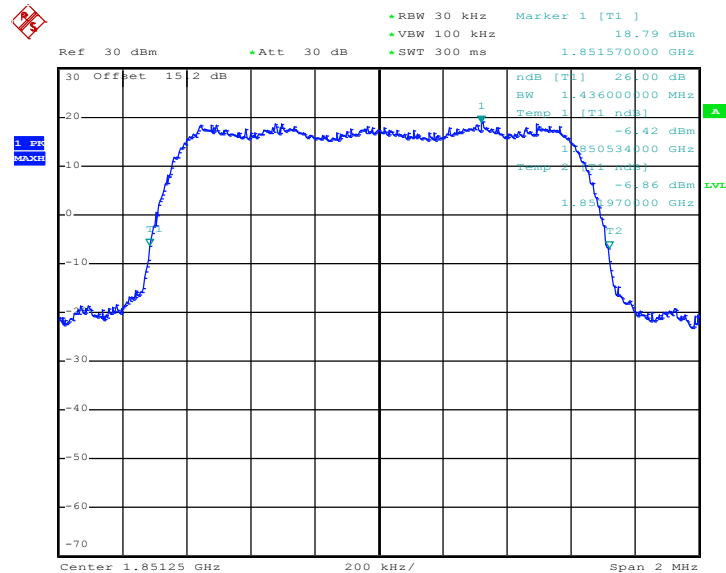

Date: 22.MAR.2012 14:04:21



99% Occupied Bandwidth Plot on Channel 600

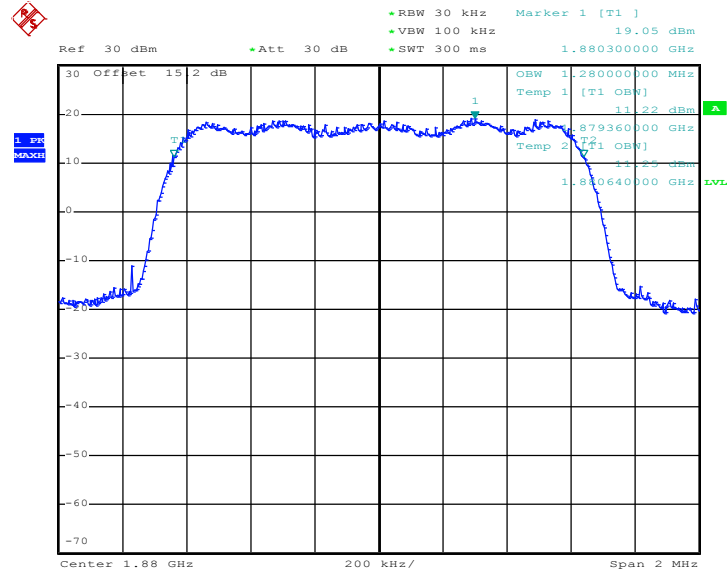

Date: 22.MAR.2012 14:08:30

26dB Bandwidth Plot on Channel 600

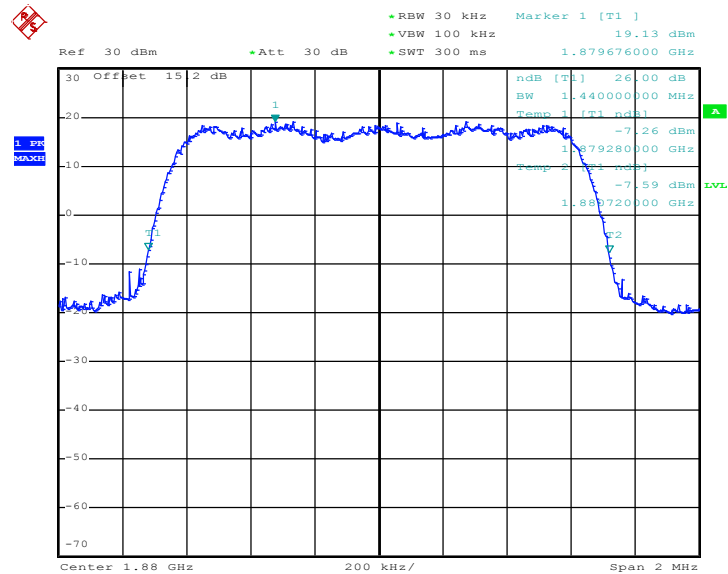

Date: 22.MAR.2012 14:05:10



99% Occupied Bandwidth Plot on Channel 1175

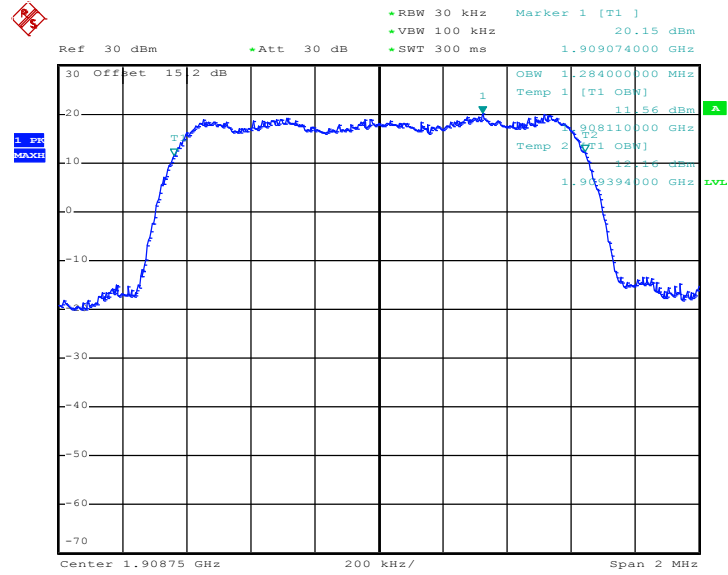

Date: 22.MAR.2012 14:15:25

26dB Bandwidth Plot on Channel 1175

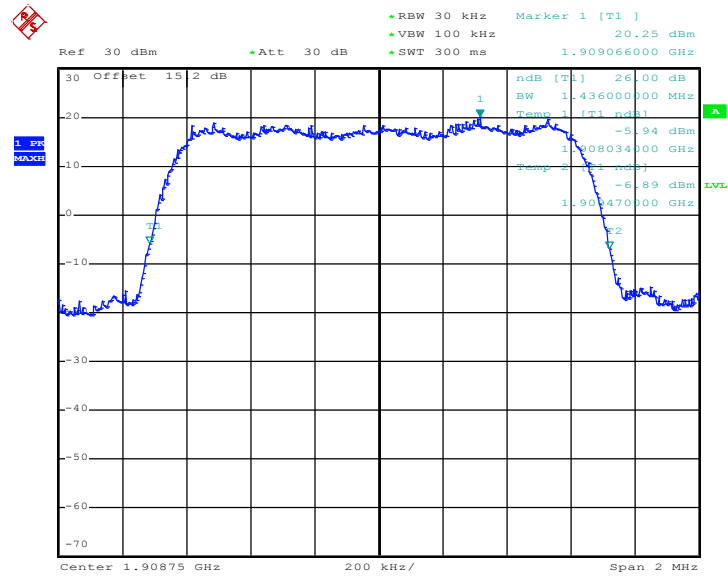

Date: 22.MAR.2012 14:05:55

### 3.4 Band Edge Measurement

#### 3.4.1 Description of Band Edge Measurement

The power of any emission outside of the authorized operating frequency ranges must be lower than the transmitter power (P) by a factor of at least  $43 + 10 \log (P)$  dB.

#### 3.4.2 Measuring Instruments

See list of measuring instruments of this test report.

#### 3.4.3 Test Procedures

1. The EUT was connected to Spectrum Analyzer and Base Station via power divider.
2. The band edges of low and high channels for the highest RF powers were measured. Setting RBW as roughly  $BW/100$ .
3. The RBW was replaced by 10 kHz, slightly smaller than the value in (2), due to the spectrum analyzer limitation to set the exact value. A worst case correction factor of  $10 \cdot \log (1\% \text{ emission-BW/measurement RBW})$  was compensated.

#### 3.4.4 Test Setup

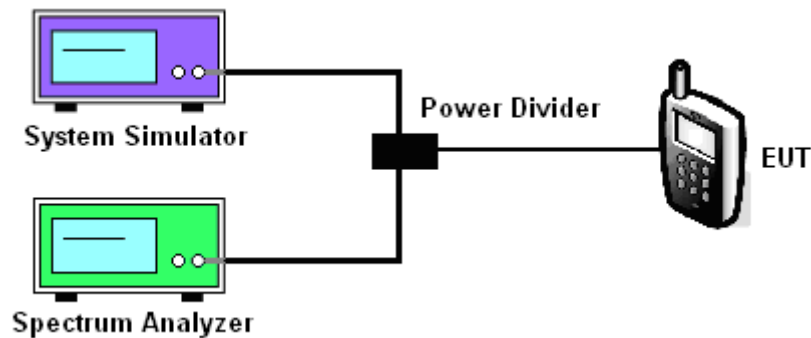



3.4.5 Test Result (Plots) of Conducted Band Edge

Band :	CDMA2000 BC1	Power Stage :	High
Test Mode :	1xRTT_RC3+SO32	Maximum 26dB Bandwidth :	1.440MHz
Correction Factor :	1.58dB	Measurement Value :	-36.10dBm
Band Edge :	-34.52dBm		

Lower Band Edge Plot on Channel 25

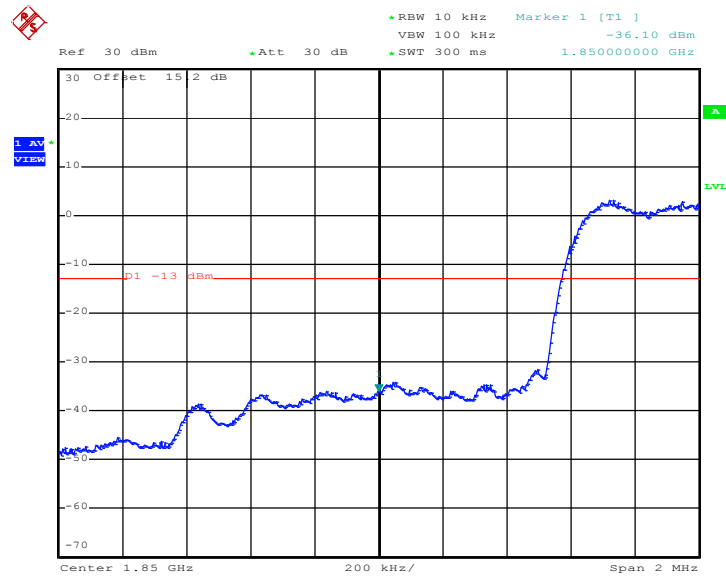

Date: 22.MAR.2012 13:59:22

1. Correction Factor(dB)= 10log(1% Emission BW/RBW)
2. Band Edge= Measurement Value + Correction Factor(dB)



Band :	CDMA2000 BC1	Power Stage :	High
Test Mode :	1xRTT_RC3+SO32	Maximum 26dB Bandwidth :	1.440MHz
Correction Factor :	1.58dB	Measurement Value :	-35.75dBm
Band Edge :	-34.17dBm		

Higher Band Edge Plot on Channel 1175

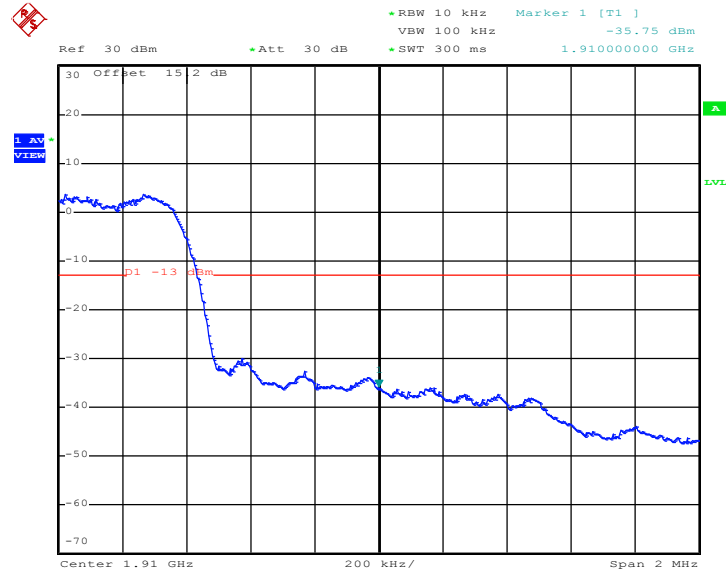

Date: 22.MAR.2012 14:01:32

1. Correction Factor(dB)=  $10\log(1\% \text{ Emission BW/RBW})$
2. Band Edge= Measurement Value + Correction Factor(dB)

## 3.5 Conducted Emission Measurement

### 3.5.1 Description of Conducted Emission Measurement

The power of any emission outside of the authorized operating frequency ranges must be lower than the transmitter power (P) by a factor of at least  $43 + 10 \log (P)$  dB.

It is measured by means of a calibrated spectrum analyzer and scanned from 30 MHz up to a frequency including its 10<sup>th</sup> harmonic.

### 3.5.2 Measuring Instruments

See list of measuring instruments of this test report.

### 3.5.3 Test Procedures

1. The EUT was connected to spectrum analyzer and base station via power divider.
2. The middle channel for the highest RF power within the transmitting frequency was measured.
3. The conducted spurious emission for the whole frequency range was taken.

### 3.5.4 Test Setup

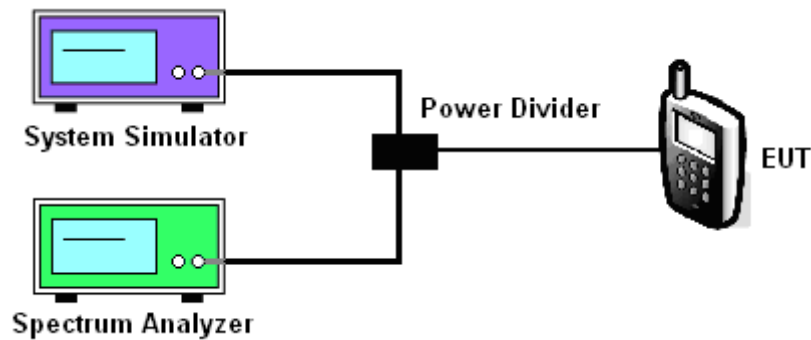

### 3.5.5 Test Result (Plots) of Conducted Emission

Band :	CDMA2000 BC1	Power Stage :	High
Test Mode :	1xRTT_RC3+SO32		

Conducted Emission Plot between 30MHz ~ 1GHz

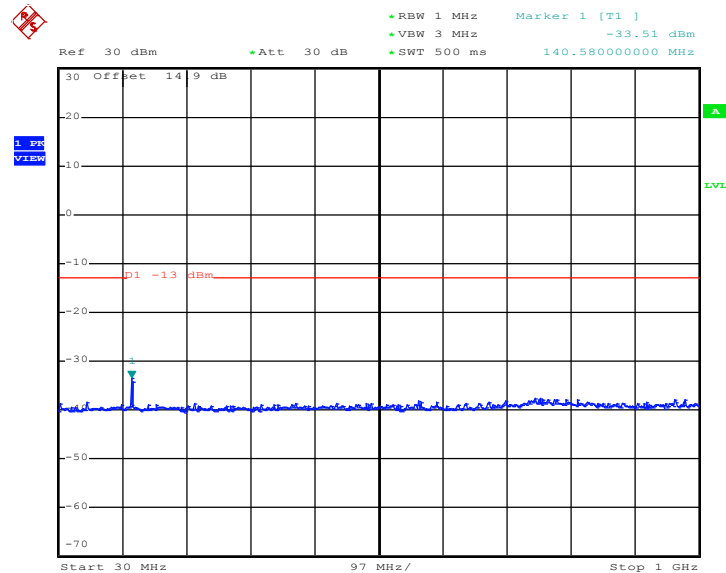

Date: 22.MAR.2012 15:22:33

Conducted Emission Plot between 1GHz ~ 3GHz

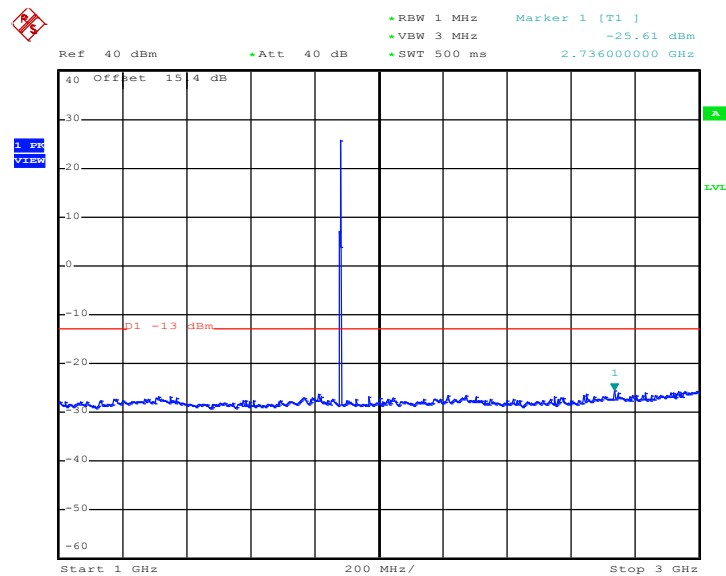

Date: 22.MAR.2012 15:24:38



Conducted Emission Plot between 3GHz ~ 7GHz

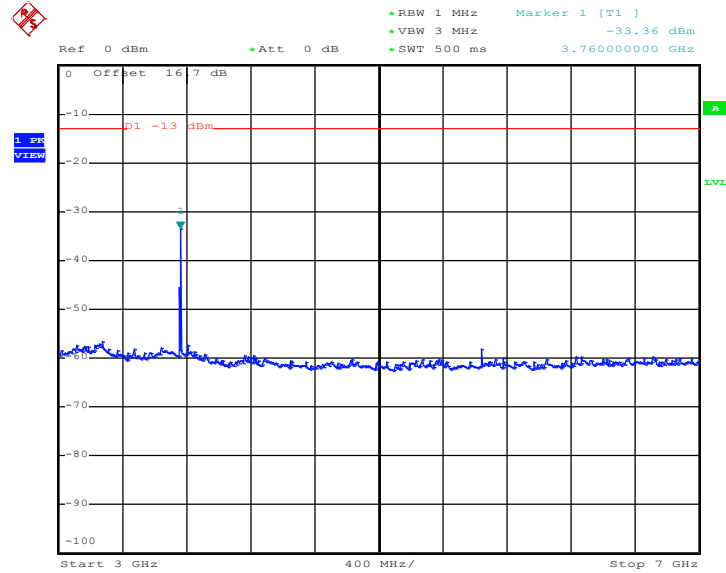

Date: 22.MAR.2012 15:25:52

Conducted Emission Plot between 7GHz ~ 13.6GHz

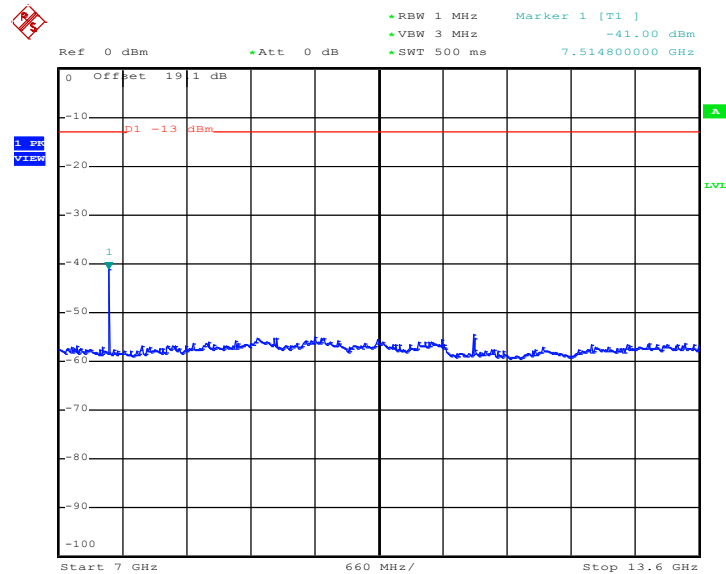

Date: 22.MAR.2012 15:29:22



Conducted Emission Plot between 13.6GHz ~ 19.1GHz

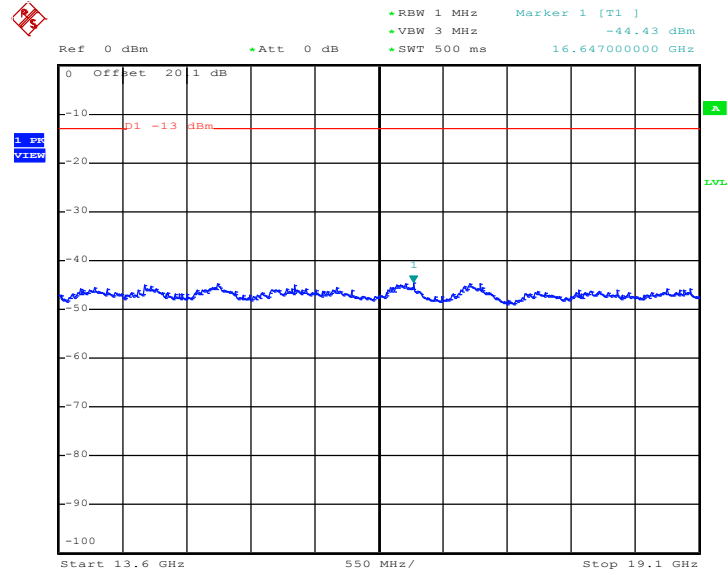

Date: 22.MAR.2012 15:32:19



## **3.6 Field Strength of Spurious Radiation Measurement**

### **3.6.1 Description of Field Strength of Spurious Radiated Measurement**

The radiated spurious emission was measured by substitution method according to ANSI / TIA / EIA-603-C-2004. The power of any emission outside of the authorized operating frequency ranges must be attenuated below the transmitter power (P) by a factor of at least  $43+10\log_{10}(P[\text{Watts}])$  dB. The spectrum is scanned from 30 MHz up to a frequency including its 10th harmonic.

### **3.6.2 Measuring Instruments**

See list of measuring instruments of this test report.

### **3.6.3 Test Procedures**

1. The EUT was placed on a rotatable wooden table with 0.8 meter about ground.
2. The EUT was set 3 meters from the receiving antenna, which was mounted on the antenna tower.
3. The table was rotated 360 degrees to determine the position of the highest spurious emission.
4. The height of the receiving antenna is varied between one meter and four meters to search the maximum spurious emission for both horizontal and vertical polarizations.
5. Make the measurement with the spectrum analyzer's RBW = 1MHz, VBW = 3MHz, Sweep = 500ms, Taking the record of maximum spurious emission.
6. A horn antenna was substituted in place of the EUT and was driven by a signal generator.
7. Tune the output power of signal generator to the same emission level with EUT maximum spurious emission.
8. Taking the record of output power at antenna port.
9. Repeat step 7 to step 8 for another polarization.
10.  $\text{EIRP (dBm)} = \text{S.G. Power} - \text{Tx Cable Loss} + \text{Tx Antenna Gain}$
11.  $\text{ERP (dBm)} = \text{EIRP} - 2.15$

### 3.6.4 Test Setup

For radiated emissions below 30MHz

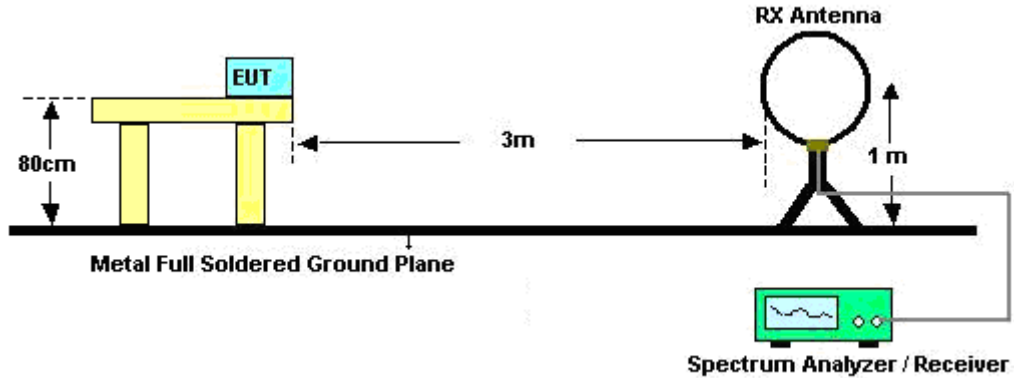

For radiated emissions above 30MHz

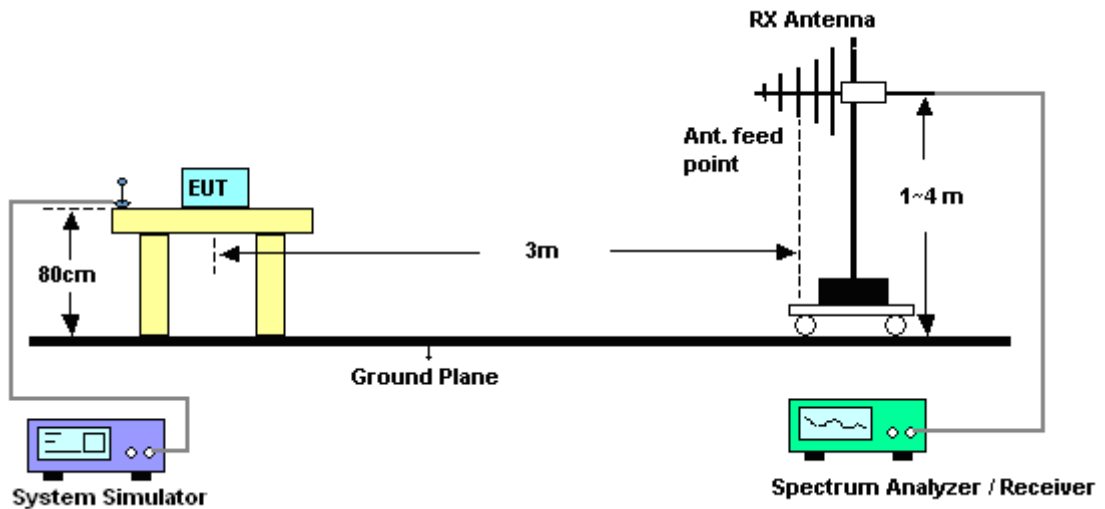

### 3.6.5 Test Results of Radiated Emissions (9 KHz ~ 30 MHz)

The low frequency, which started from 9 KHz to 30MHz, was pre-scanned and the result which was 20dB lower than the limit line per 15.31(o) was not reported.



3.6.6 Test Result of Field Strength of Spurious Radiated

Band :	CDMA2000 BC1	Temperature :	21~22°C
Test Mode :	1xRTT_RC3+SO32	Relative Humidity :	41~42%
Test Engineer :	Steven Hao	Polarization :	Horizontal
Remark :	Spurious emissions within 30-1000MHz were found more than 20dB below limit line.		

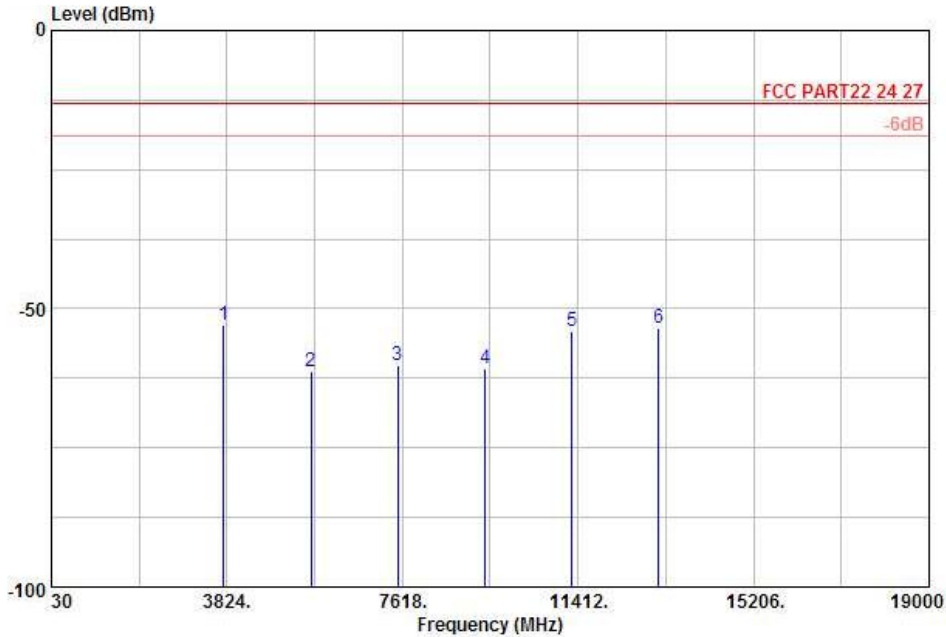

Site : 03CH01-KS  
 Condition: FCC PART 24 HF EIRP FACTOR-09020 HORIZONTAL  
 Project : (FG) 230757  
 Plan : E2

Frequency ( MHz )	EIRP ( dBm )	Limit ( dBm )	Over Limit ( dB )	SPA Reading ( dBm )	S.G. Power ( dBm )	TX Cable loss ( dB )	TX Antenna Gain ( dBi )	Polarization ( H/V )	Result
3760	-53.03	-13	-40.03	-54.45	-59.41	0.78	7.16	H	Pass
5640	-61.31	-13	-48.31	-65.49	-69.85	1.04	9.58	H	Pass
7520	-60.10	-13	-47.10	-65.23	-70.21	1.35	11.46	H	Pass
9400	-60.59	-13	-47.59	-63.85	-71.65	1.75	12.81	H	Pass
11280	-54.05	-13	-41.05	-65.54	-65.14	2	13.09	H	Pass
13160	-53.48	-13	-40.48	-64.78	-65.19	2.04	13.75	H	Pass



<b>Band :</b>	CDMA2000 BC1	<b>Temperature :</b>	21~22°C
<b>Test Mode :</b>	1xRTT_RC3+SO32	<b>Relative Humidity :</b>	41~42%
<b>Test Engineer :</b>	Steven Hao	<b>Polarization :</b>	Vertical
<b>Remark :</b>	Spurious emissions within 30-1000MHz were found more than 20dB below limit line.		

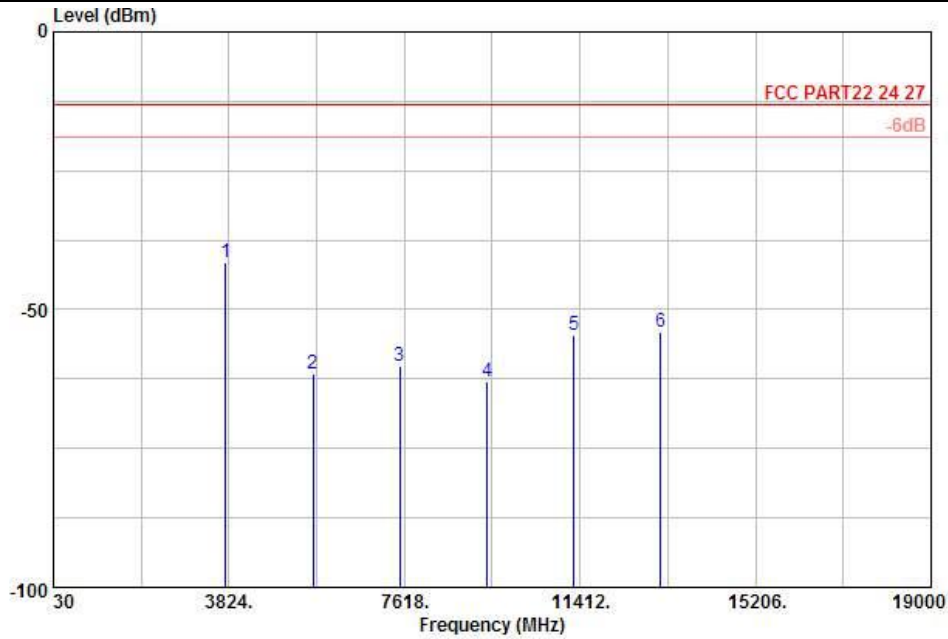

Site : 03CH01-KS  
 Condition: FCC PART 24 HF EIRP FACTOR-09020 VERTICAL  
 Project : (FG) 230757  
 Plan : E2

Frequency ( MHz )	EIRP ( dBm )	Limit ( dBm )	Over Limit ( dB )	SPA Reading ( dBm )	S.G. Power ( dBm )	TX Cable loss ( dB )	TX Antenna Gain ( dBi )	Polarization ( H/V )	Result
3760	-41.43	-13	-28.43	-49.87	-47.81	0.78	7.16	V	Pass
5640	-61.69	-13	-48.69	-64.91	-70.23	1.04	9.58	V	Pass
7520	-60.19	-13	-47.19	-64.68	-70.30	1.35	11.46	V	Pass
9400	-62.91	-13	-49.91	-64.13	-73.97	1.75	12.81	V	Pass
11280	-54.46	-13	-41.46	-65.7	-65.55	2	13.09	V	Pass
13160	-54.11	-13	-41.11	-65.3	-65.82	2.04	13.75	V	Pass

## 3.7 Frequency Stability Measurement

### 3.7.1 Description of Frequency Stability Measurement

The frequency stability shall be measured by variation of ambient temperature and variation of primary supply voltage to ensure that the fundamental emission stays within the authorized frequency block. The frequency stability of the transmitter shall be maintained within  $\pm 0.00025\%$  ( $\pm 2.5\text{ppm}$ ) of the center frequency.

### 3.7.2 Measuring Instruments

See list of measuring instruments of this test report.

### 3.7.3 Test Procedures for Temperature Variation

1. The EUT was set up in the thermal chamber and connected with the base station.
2. With power OFF, the temperature was decreased to  $-30^{\circ}\text{C}$  and the EUT was stabilized for three hours. Power was applied and the maximum change in frequency was recorded within one minute.
3. With power OFF, the temperature was raised in  $10^{\circ}\text{C}$  step up to  $50^{\circ}\text{C}$ . The EUT was stabilized at each step for at least half an hour. Power was applied and the maximum frequency change was recorded within one minute.
4. If the EUT cannot be turned on at  $-30^{\circ}\text{C}$ , the testing lowest temperature will be raised in  $10^{\circ}\text{C}$  step until the EUT can be turned on.

### 3.7.4 Test Procedures for Voltage Variation

1. The EUT was placed in a temperature chamber at  $25\pm 5^{\circ}\text{C}$  and connected with the base station.
2. The power supply voltage to the EUT was varied from BEP to 115% of the nominal value measured at the input to the EUT.
3. The variation in frequency was measured for the worst case.

3.7.5 Test Setup

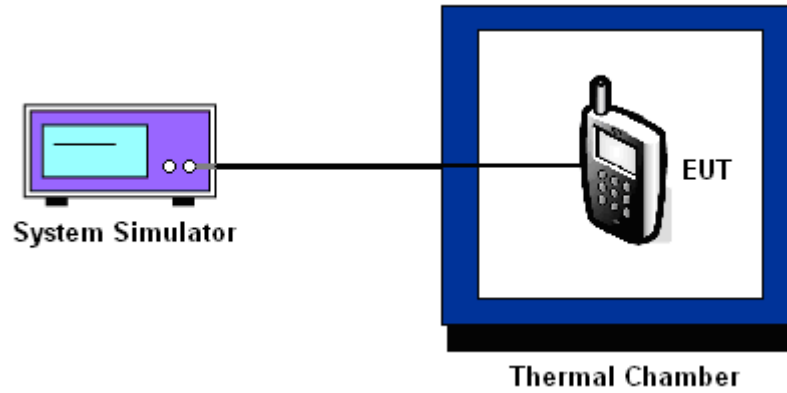

3.7.6 Test Result of Temperature Variation

Band :	CDMA2000 BC1	Channel :	600
Test Mode :	1xRTT_RC3+SO32	Limit (ppm) :	2.5

Temperature (°C)	Freq. Dev. (Hz)	Deviation (ppm)	Result
-30	N/A	N/A	PASS
-20	N/A	N/A	
-10	10	0.01	
0	-12	-0.01	
10	-14	-0.01	
20	-16	-0.01	
30	-19	-0.01	
40	-25	-0.01	
50	-21	-0.01	
55	-29	-0.02	

**Note:** The manufacturer declared that the EUT could work properly between temperatures -10°C~55°C.



3.7.7 Test Result of Voltage Variation

Band & Channel	Mode	Voltage (Volt)	Freq. Dev. (Hz)	Deviation (ppm)	Limit (ppm)	Result
CDMA2000 BC1 CH600	1xRTT RC3+SO32	3.80	-28	-0.01	2.5	PASS
		BEP	-15	-0.01		
		4.35	-21	-0.01		

Note :

- 1. Normal Voltage = 3.80V.
- 2. Battery End Point (BEP) = 3.60 V.



## 4 List of Measuring Equipment

Instrument	Manufacturer	Model No.	Serial No.	Characteristics	Calibration Date	Test Date	Due Date	Remark
Spectrum Analyzer	R&S	FSP40	100319	9kHz~40GHz	Dec. 30, 2011	Mar. 22, 2012	Dec. 29, 2012	Conducted (TH01-KS)
Thermal Chamber	Ten Billion	TTC-B3S	TBN-960502	N/A	Dec. 30, 2011	Mar. 22, 2012	Dec. 29, 2012	Conducted (TH01-KS)
EMI Test Receiver	R&S	ESCI	100534	9kHz~3GHz	Nov. 09, 2011	Mar. 13, 2012 ~ Apr. 11, 2012	Nov. 08, 2012	Radiation (03CH01-KS)
Spectrum Analyzer	R&S	FSP40	100319	9kHz~40GHz	Dec. 30, 2011	Mar. 13, 2012 ~ Apr. 11, 2012	Dec. 29, 2012	Radiation (03CH01-KS)
Spectrum Analyzer	R&S	FSP30	101400	9kHz~30GHz	Jun. 02, 2011	Mar. 13, 2012 ~ Apr. 11, 2012	Jun. 01, 2012	Radiation (03CH01-KS)
Bilog Antenna	SCHAFFNER	CBL6112D	23182	25MHz~2GHz	Dec. 08, 2011	Mar. 13, 2012 ~ Apr. 11, 2012	Dec. 07, 2012	Radiation (03CH01-KS)
Double Ridge Horn Antenna	EMCO	3117	00075959	1GHz~18GHz	Jan. 06, 2012	Mar. 13, 2012 ~ Apr. 11, 2012	Jan. 05, 2013	Radiation (03CH01-KS)
Amplifier	Wireless	FPA-6592G	060029	9KHz~2GHz	Jan. 06, 2012	Mar. 13, 2012 ~ Apr. 11, 2012	Jan. 05, 2013	Radiation (03CH01-KS)
Amplifier	Wireless	FPA-6592G	060004	30MHz~2GHz	Dec. 30, 2011	Mar. 13, 2012 ~ Apr. 11, 2012	Dec. 29, 2012	Radiation (03CH01-KS)
Amplifier	Agilent	8449B	3008A02370	1GHz~26.5GHz	Dec. 30, 2011	Mar. 13, 2012 ~ Apr. 11, 2012	Dec. 29, 2012	Radiation (03CH01-KS)
Active Horn Antenna	com-power	AHA-118	701023	1G-18GHz	Nov. 07, 2011	Mar. 13, 2012 ~ Apr. 11, 2012	Nov. 06, 2012	Radiation (03CH01-KS)
SHF-EHF Horn	Schwarzbeck	BBHA 9170	BBHA170249	15-40GHz	Oct. 11, 2011	Mar. 13, 2012 ~ Apr. 11, 2012	Oct. 10, 2012	Radiation (03CH01-KS)
Loop Antenna	R&S	HFH2-Z2	860004/001	9 kHz~30 MHz	Jul. 29, 2010	Mar. 13, 2012 ~ Apr. 11, 2012	Jul. 28, 2012	Radiation (03CH01-KS)
System Simulator	R&S	CMU200	116456	Full-Band	Sep. 20, 2011	Mar. 13, 2012 ~ Apr. 11, 2012	Sep. 19, 2012	-

## 5 Uncertainty of Evaluation

### Uncertainty of Radiated Emission Measurement (30 MHz ~ 1000 MHz)

Contribution	Uncertainty of $X_i$		$u(X_i)$
	dB	Probability Distribution	
Receiver Reading	0.41	Normal (k=2)	0.21
Antenna Factor Calibration	0.83	Normal (k=2)	0.42
Cable Loss Calibration	0.25	Normal (k=2)	0.13
Pre-Amplifier Gain Calibration	0.27	Normal (k=2)	0.14
RCV/SPA Specification	2.50	Rectangular	0.72
Antenna Factor Interpolation for Frequency	1.00	Rectangular	0.29
Site Imperfection	1.43	Rectangular	0.83
Mismatch	+0.39 / -0.41	U-Shape	0.28
<b>Combined Standard Uncertainty <math>U_c(y)</math></b>	<b>1.27</b>		
<b>Measuring Uncertainty for a Level of Confidence of 95% (<math>U = 2U_c(y)</math>)</b>	<b>2.54</b>		

### Uncertainty of Radiated Emission Measurement (1 GHz ~ 40 GHz)

Contribution	Uncertainty of $X_i$		$u(X_i)$	$C_i$	$C_i * u(X_i)$
	dB	Probability Distribution			
Receiver Reading	$\pm 0.10$	Normal (k=2)	0.10	1	0.10
Antenna Factor Calibration	$\pm 1.70$	Normal (k=2)	0.85	1	0.85
Cable Loss Calibration	$\pm 0.50$	Normal (k=2)	0.25	1	0.25
Receiver Correction	$\pm 2.00$	Rectangular	1.15	1	1.15
Antenna Factor Directional	$\pm 1.50$	Rectangular	0.87	1	0.87
Site Imperfection	$\pm 2.80$	Triangular	1.14	1	1.14
Mismatch Receiver VSWR $\Gamma_1 = 0.197$ Antenna VSWR $\Gamma_2 = 0.194$ Uncertainty = $20\text{Log}(1-\Gamma_1*\Gamma_2)$	+0.34 / -0.35	U-Shape	0.244	1	0.244
<b>Combined Standard Uncertainty <math>U_c(y)</math></b>	<b>2.36</b>				
<b>Measuring Uncertainty for a Level of Confidence of 95% (<math>U = 2U_c(y)</math>)</b>	<b>4.72</b>				