



Report No.: RZC1101-0124RF02



# Part 15C

# TEST REPORT

Product Name CDMA1x PCS only mobile phone

FCC ID IHDT56MU1

Model WX430

Client BYD Precision Manufacture Company Limited Shanghai Branch

**TA Technology (Shanghai) Co., Ltd.**



## GENERAL SUMMARY

|                              |  |              |       |
|------------------------------|--|--------------|-------|
| <b>Product Name</b>          | CDMA1x PCS only mobile phone   | <b>Model</b> | WX430 |
| <b>FCC ID</b>                | IHDT56MU1  |              |       |
| <b>Report No.</b>            | RZC1101-0124RF02   |              |       |
| <b>Client</b>                | BYD Precision Manufacture Company Limited Shanghai Branch  |              |       |
| <b>Manufacturer</b>          | Motorola Mobility  |              |       |
| <b>Reference Standard(s)</b> | <p><b>FCC CFR47 Part 15C (2010-12)</b> Radio Frequency Devices</p> <p><b>15.205</b> Restricted bands of operation;</p> <p><b>15.207</b> Conducted limits;</p> <p><b>15.209</b> Radiated emission limits; general requirements;</p> <p><b>15.247</b> Operation within the bands 902-928 MHz,2400-2483.5 MHz, and 5725-5850MHz.</p> <p><b>ANSI C63.4</b> Methods of Measurement of Radio-Noise Emission from Low-Voltage Electrical and Electronic Equipment in the Range of 9 KHz to 40GHz. (2003)</p> <p><b>DA00-705</b> Filing and Frequency Measurement Guidelines For Frequency Hopping Spread Spectrum System.(2000)</p> |              |       |
| <b>Conclusion</b>            | <p>This portable wireless equipment has been measured in all cases requested by the relevant standards. Test results in Chapter 2 of this test report are below limits specified in the relevant standards.</p> <p>General Judgment: <b>Pass</b></p> <p style="text-align: right;">(Stamp)<br/>Date of issue: January 28<sup>th</sup>, 2011</p>  |              |       |
| <b>Comment</b>               | The test result only responds to the measured sample.  |              |       |

Approved by

by

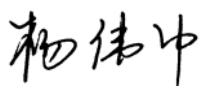

Yang Weizhong

Revised by



Xu Kai

Performed by



Du Ruwei

## TABLE OF CONTENT

|   |    |
|---|----|
| 1. General Information .....                                  | 4  |
| 1.1. Notes of the test report.....                            | 4  |
| 1.2. Testing laboratory .....                                 | 4  |
| 1.3. Applicant Information .....                              | 5  |
| 1.4. Manufacturer Information.....                            | 5  |
| 1.5. Information of EUT .....                                 | 6  |
| 1.6. Test Date .....  | 7  |
| 1.7. Test Report Revision.....                                | 7  |
| 2. Test Information.....                                      | 8  |
| 2.1. Summary of test results .....                            | 8  |
| 2.2. Peak Power Output –Conducted.....                        | 9  |
| 2.3. Occupied Bandwidth (20dB) .....                          | 14 |
| 2.4. Frequency Separation.....                                | 19 |
| 2.5. Time of Occupancy (Dwell Time) .....                     | 24 |
| 2.6. Band Edge Compliance .....                               | 29 |
| 2.7. Spurious Radiated Emissions in the Restricted Band ..... | 34 |
| 2.8. Number of hopping Frequency.....                         | 38 |
| 2.9. Spurious RF Conducted Emissions.....                     | 43 |
| 2.10. Radiates Emission.....                                  | 57 |
| 2.11. Conducted Emission.....                                 | 77 |
| 3. Main Test Instruments .....                                | 90 |
| ANNEX A: EUT Appearance and Test Setup.....                   | 91 |

## **1. General Information**

### **1.1. Notes of the test report**

**TA Technology (Shanghai) Co., Ltd.** guarantees the reliability of the data presented in this test report, which is the results of measurements and tests performed for the items under test on the date and under the conditions stated in this test report and is based on the knowledge and technical facilities available at TA Technology (Shanghai) Co., Ltd. at the time of execution of the test.

**TA Technology (Shanghai) Co., Ltd.** is liable to the client for the maintenance by its personnel of the confidentiality of all information related to the items under test and the results of the test. This report only refers to the item that has undergone the test.

This report standalone dose not constitute or imply by its own an approval of the product by the certification Bodies or competent Authorities. This report cannot be used partially or in full for publicity and/or promotional purposes without previous written approval of **TA Technology (Shanghai) Co., Ltd.** and the Accreditation Bodies, if it applies.

If the electrical report is inconsistent with the printed one, it should be subject to the latter.

### **1.2. Testing laboratory**

Company: TA Technology (Shanghai) Co., Ltd.  
Address: No.145, Jintang Rd, Tangzhen Industry Park, Pudong  
City: Shanghai  
Post code: 201201  
Country: P. R. China  
Contact: Yang Weizhong  
Telephone: +86-021-50791141/2/3  
Fax: +86-021-50791141/2/3-8000  
Website: <http://www.ta-shanghai.com>  
E-mail: [yangweizhong@ta-shanghai.com](mailto:yangweizhong@ta-shanghai.com)

**TA Technology (Shanghai) Co., Ltd.**  
**Test Report**

Registration Num:428261

Report No.: RZC1101-0124RF02

Page 5 of 91

---

**1.3. Applicant Information**

Company: BYD Precision Manufacture Company Limited Shanghai Branch  
Address: F7,Building 5, Longdong Ave 3000, Pudong District. Shanghai  
City: Shanghai  
Postal Code: 201203  
Country: P.R. China  
Contact: Konger.Kong  
Telephone: 02161009669-72114  
Fax: 02161009668

**1.4. Manufacturer Information**

Company: Motorola Mobility  
Address: 8000 W Sunrise Blvd.  
Plantation, FL, 33322  
City: /  
Postal Code: 33322  
Country: United States  
Telephone: (954)914-3206  
Fax: /

## 1.5. Information of EUT

### General information

|                                  |                                 |                         |
|----------------------------------|---------------------------------|-------------------------|
| Name of EUT:                     | CDMA1x PCS only mobile phone    |                         |
| MEID:                            | A0000022FC151E/ A0000022FC15ED  |                         |
| Hardware Version:                | 200002                          |                         |
| Software Version:                | HALLC2_X_00.01.0S1              |                         |
| Device Operating Configurations: |                                 |                         |
| Mode                             | Basic Rate                      | Enhanced Data Rate(EDR) |
| Modulation                       | GFSK                            | 8DQPSK                  |
| Packet Type:(Maximum Payload)    | DH5                             | 3DH5                    |
| Max Conducted Power              | 10.08dBm                        |                         |
| Antenna Type:                    | Internal Antenna                |                         |
| Power Supply:                    | Battery or Adapter              |                         |
| Rated Power Supply Voltage:      | 3.7V                            |                         |
| Extreme Voltage:                 | Minimum: 3.2V    Maximum: 4.2V  |                         |
| Extreme Temperature:             | Lowest: -30°C    Highest: +60°C |                         |
| Operating Frequency Range(s)     | 2400 ~ 2483.5 MHz               |                         |

# TA Technology (Shanghai) Co., Ltd.

## Test Report

Registration Num:428261

Report No.: RZC1101-0124RF02

Page 7 of 91

### Auxiliary equipment details

#### AE1: Battery

Model: BQ50  
Manufacture: Motorola Mobility  
IMEI or SN: /

#### AE2: Travel Adaptor

Model: E199967  
Manufacture: Made in China  
IMEI or SN: /

Equipment Under Test (EUT) is CDMA1x PCS only mobile phone with internal antenna. The EUT supports Bluetooth.

The sample under test was selected by the Client.

Components list please refer to documents of the manufacturer.

### 1.6. Test Date

The test is performed from January 27, 2011 to January 28, 2011.

### 1.7. Test Report Revision

| Date          | Report No        | Revision | Description    |
|---------------|------------------|----------|----------------|
| Jan. 28 ,2011 | RZA1101-0124RF02 | 0        | First Revision |
|               |                  |          |                |

## 2. Test Information

### 2.1. Summary of test results

| <b>Number</b> | <b>Summary of measurements of results</b>          | <b>Clause in FCC rules</b> | <b>Verdict</b> |
|---------------|--|----------------------------|----------------|
| 1             | Peak Power Output -Conducted                       | 15.247(b)(1)               | PASS           |
| 2             | Occupied Bandwidth (20dB)                          | 15.247(a)(1)               | PASS           |
| 3             | Frequency Separation                               | 15.247(a)(1)               | PASS           |
| 4             | Time of Occupancy (Dwell Time)                     | 15.247(a)(1)(iii)          | PASS           |
| 5             | Band Edge Compliance                               | 15.247(d)                  | PASS           |
| 6             | Spurious Radiated Emissions in the restricted band | 15.247(d),15.205,15.209    | PASS           |
| 7             | Number of Hopping Frequency                        | 15.247(a)(1)(iii)          | PASS           |
| 8             | Spurious RF Conducted Emissions                    | 15.247(d)                  | PASS           |
| 9             | Radiates Emission                                  | 15.247(d),15.205,15.209    | PASS           |
| 10            | AC Power Line Conducted Emission                   | 15.207                     | PASS           |

**TA Technology (Shanghai) Co., Ltd.**  
**Test Report**

Registration Num:428261

Report No.: RZC1101-0124RF02

Page 9 of 91

## 2.2. Peak Power Output –Conducted

### Ambient condition

|             |                   |          |
|-------------|-------------------|----------|
| Temperature | Relative humidity | Pressure |
| 23°C ~25°C  | 45%~50%           | 101.5kPa |

### Methods of Measurement

During the process of the testing, The EUT was connected to the spectrum analyzer and Bluetooth test set via a power splitter with a known loss. The EUT is controlled by the Bluetooth test set to ensure max power transmission with proper modulation. The peak detector is used. RBW is set to 1MHz, VBW is set to 3MHz. These measurements have been tested at following channels: 0, 39, and 78.

### Test Setup

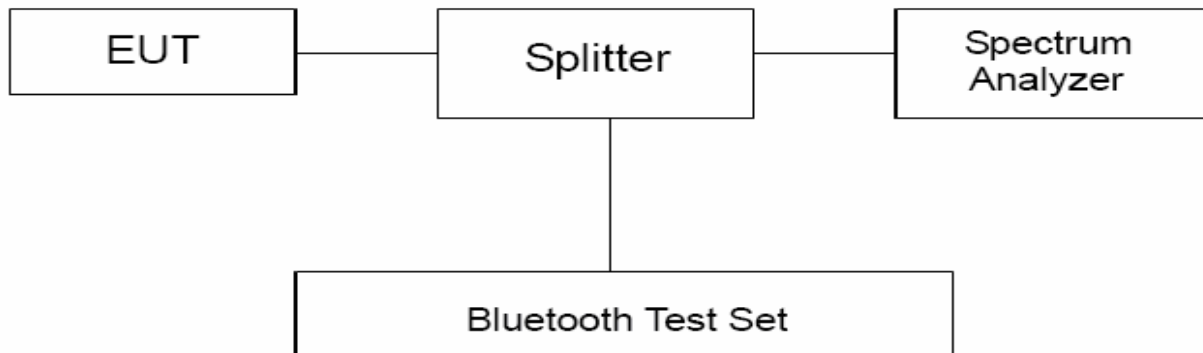

### Limits

Rule Part 15.247 (b) (1) specifies that " For frequency hopping systems operating in the 2400–2483.5 MHz band employing at least 75 non-overlapping hopping channels, and all frequency hopping systems in the 5725–5850 MHz band: 1 watt. For all other frequency hopping systems in the 2400–2483.5 MHz band: 0.125 watts."

|                   |              |
|-------------------|--------------|
| Peak Output Power | ≤ 1W (30dBm) |
|-------------------|--------------|

### Measurement Uncertainty

The assessed measurement uncertainty to ensure 95% confidence level for the normal distribution is with the coverage factor  $k = 2$ .  $U = 0.44$  dB.

# TA Technology (Shanghai) Co., Ltd. Test Report

Registration Num:428261

Report No.: RZC1101-0124RF02

Page 10 of 91

## Test Results

| Channel | Frequency (MHz) | Peak Output Power (dBm) |      | Conclusion |
|---------|-----------------|-------------------------|------|------------|
|         |                 | DH5                     | 3DH5 |            |
| 0       | 2402            | 9.22                    | 7.71 | PASS       |
| 39      | 2441            | 10.08                   | 8.62 | PASS       |
| 78      | 2480            | 8.89                    | 7.52 | PASS       |

### DH5

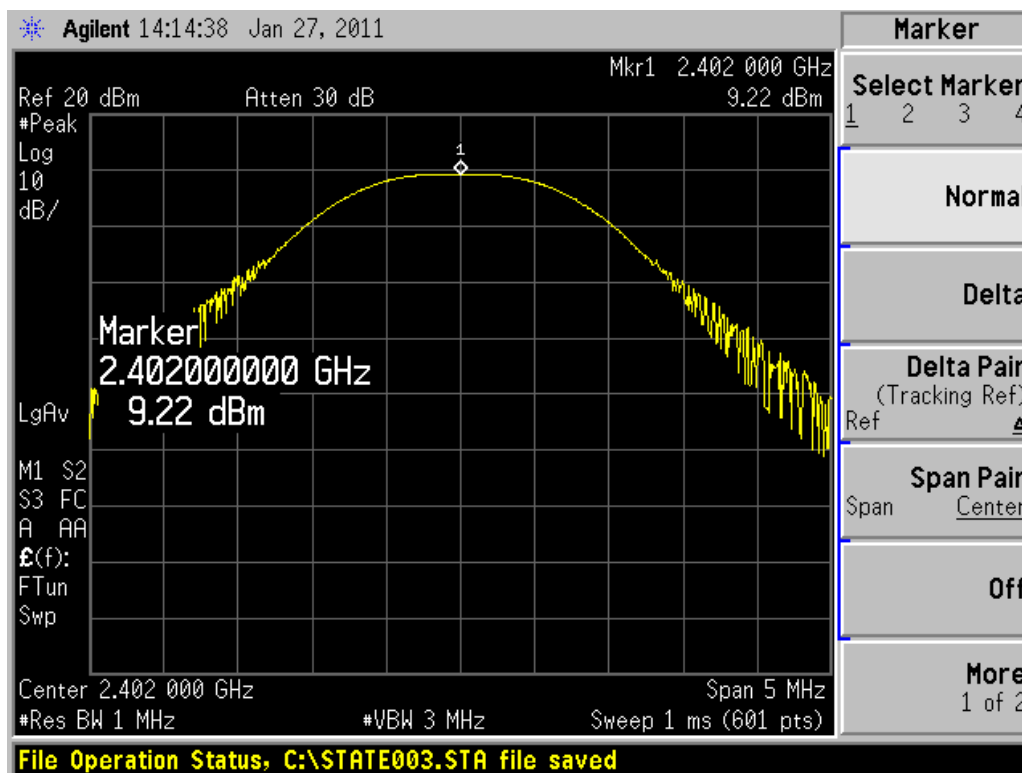

Carrier frequency (MHz): 2402

Channel No.:0

TA Technology (Shanghai) Co., Ltd.  
Test Report

Registration Num:428261

Report No.: RZC1101-0124RF02

Page 11 of 91

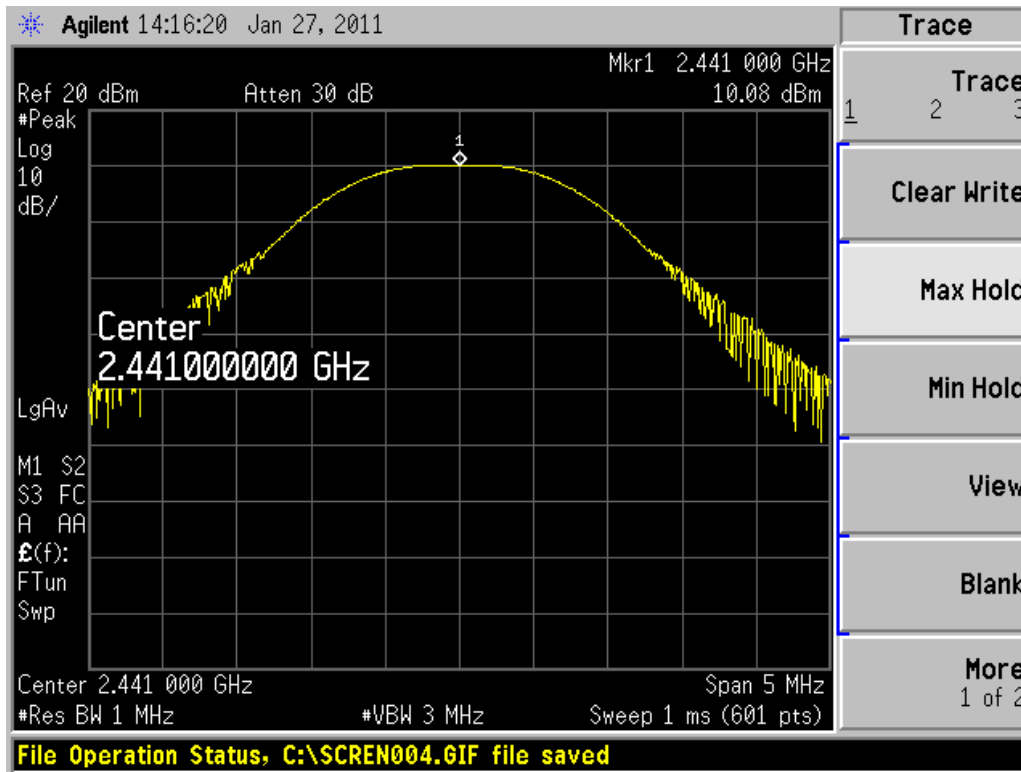

Carrier frequency (MHz): 2441

Channel No.:39

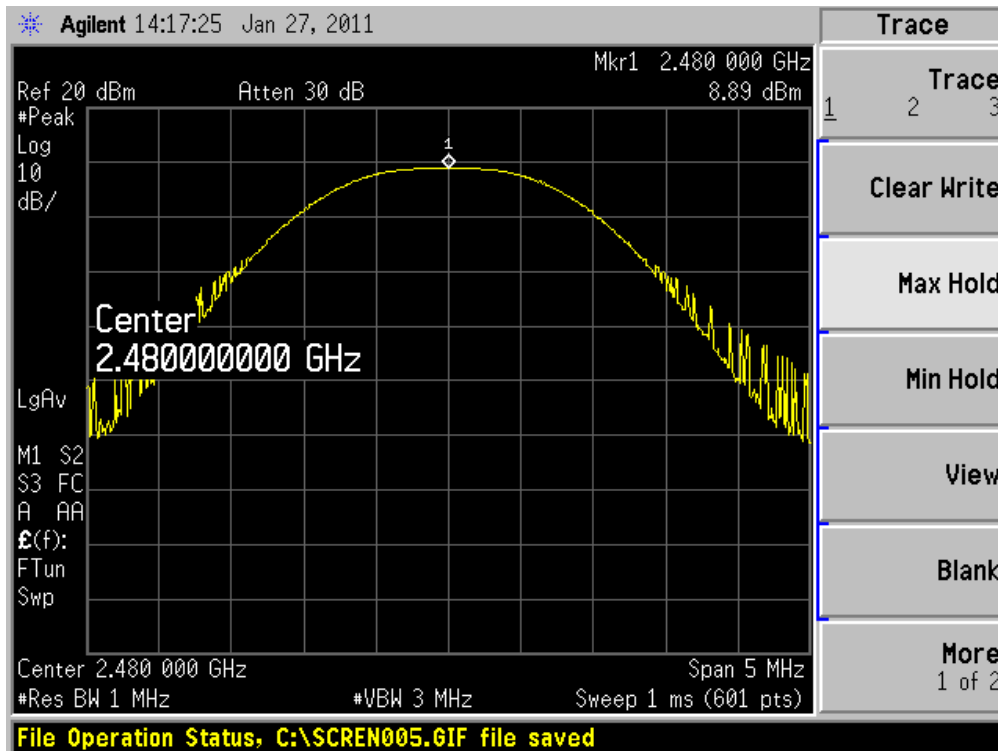

Carrier frequency (MHz): 2480

Channel No.:78

3DH5

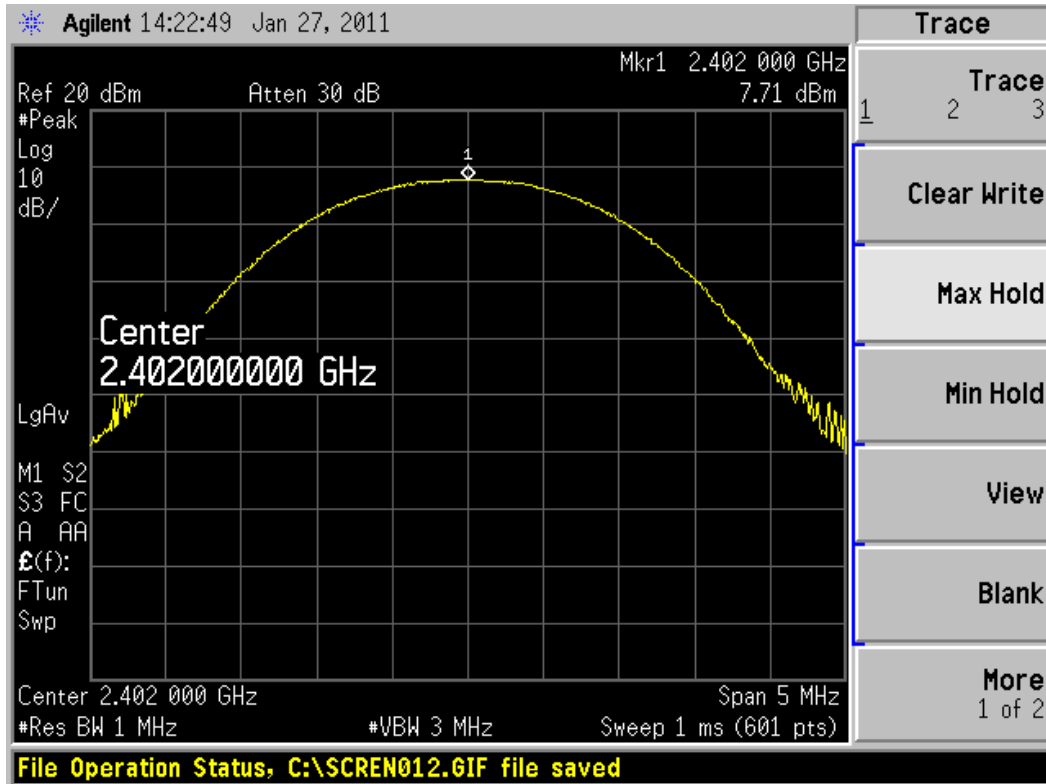

Carrier frequency (MHz): 2402

Channel No.:0

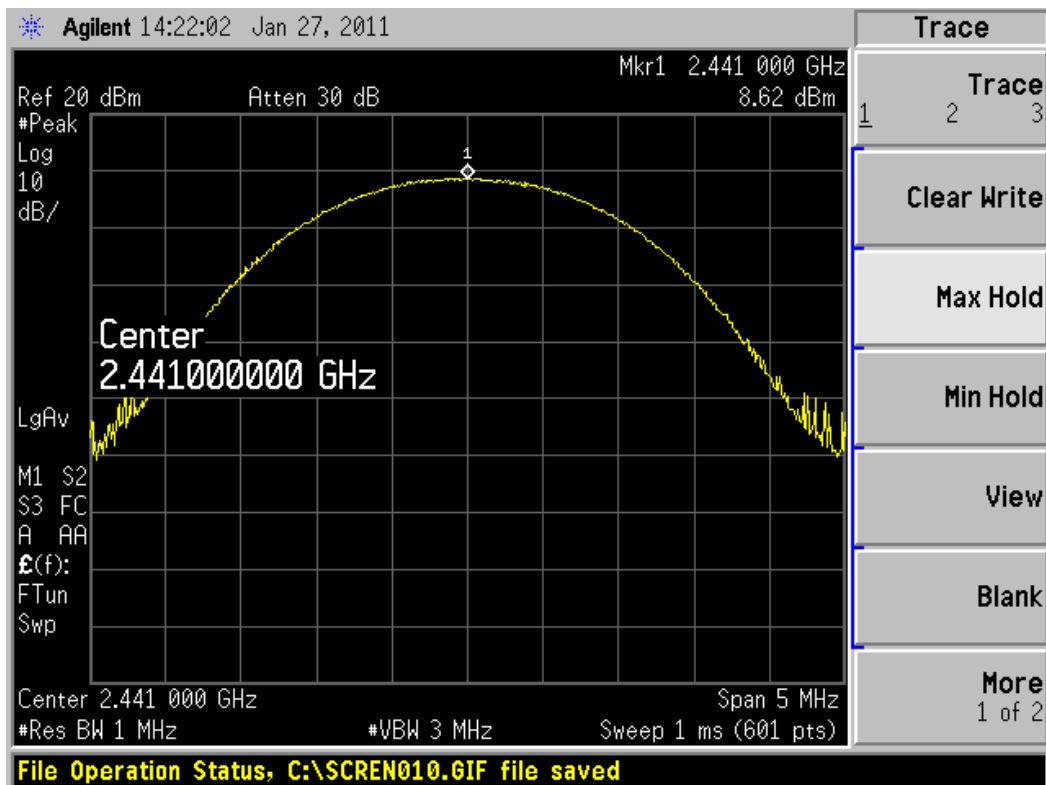

Carrier frequency (MHz): 2441

Channel No.:39

TA Technology (Shanghai) Co., Ltd.  
Test Report

Registration Num:428261

Report No.: RZC1101-0124RF02

Page 13of 91

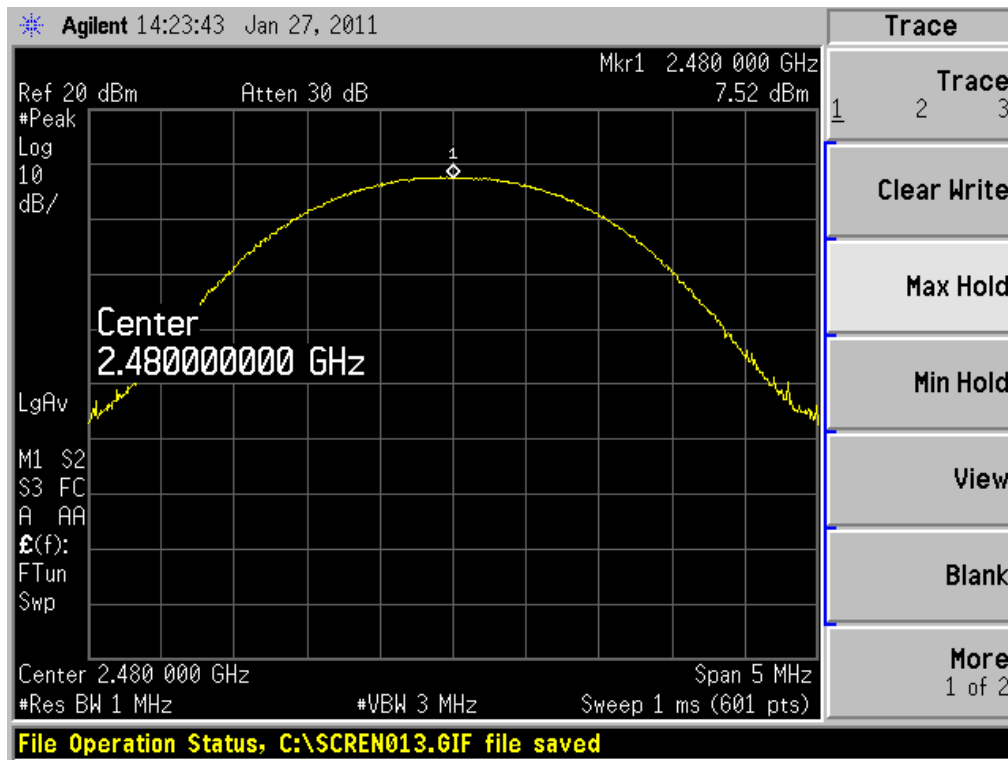

Carrier frequency (MHz): 2480

Channel No.:78

### 2.3. Occupied Bandwidth (20dB)

#### Ambient condition

|             |                   |          |
|-------------|-------------------|----------|
| Temperature | Relative humidity | Pressure |
| 23°C ~25°C  | 45%~50%           | 101.5kPa |

#### Method of Measurement

The EUT was connected to the spectrum analyzer and Bluetooth test set via a power splitter with a known loss. The occupied bandwidth is measured using spectrum analyzer. RBW is set to 10kHz and VBW is set to 30kHz on spectrum analyzer. -20dB occupied bandwidths are recorded.

#### Test Setup

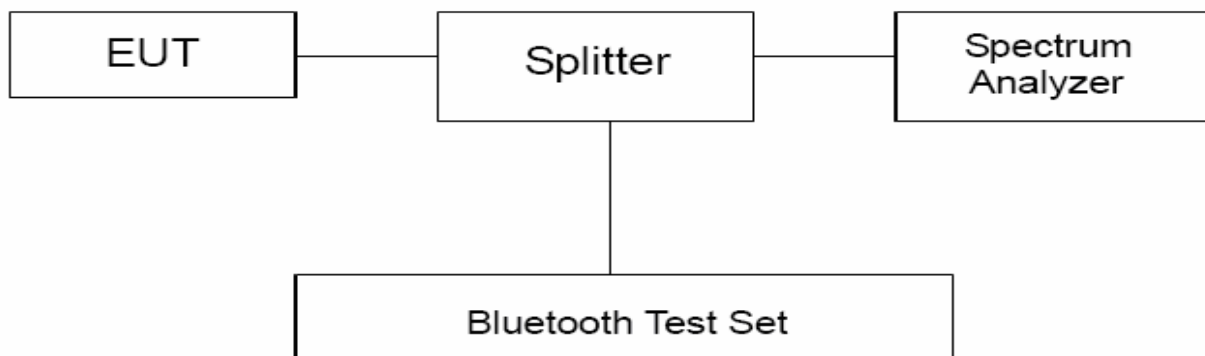

#### Limits

No specific occupied bandwidth requirements in part 15.247(a) (1).

#### Measurement Uncertainty

The assessed measurement uncertainty to ensure 95% confidence level for the normal distribution is with the coverage factor  $k = 2$ .  $U = 936$  Hz.

Test Results

DH5

| Channel | Frequency (MHz) | 20dB Bandwidth (kHz) |
|---------|-----------------|----------------------|
| 0       | 2402            | 933.775              |
| 39      | 2441            | 929.357              |
| 78      | 2480            | 932.867              |

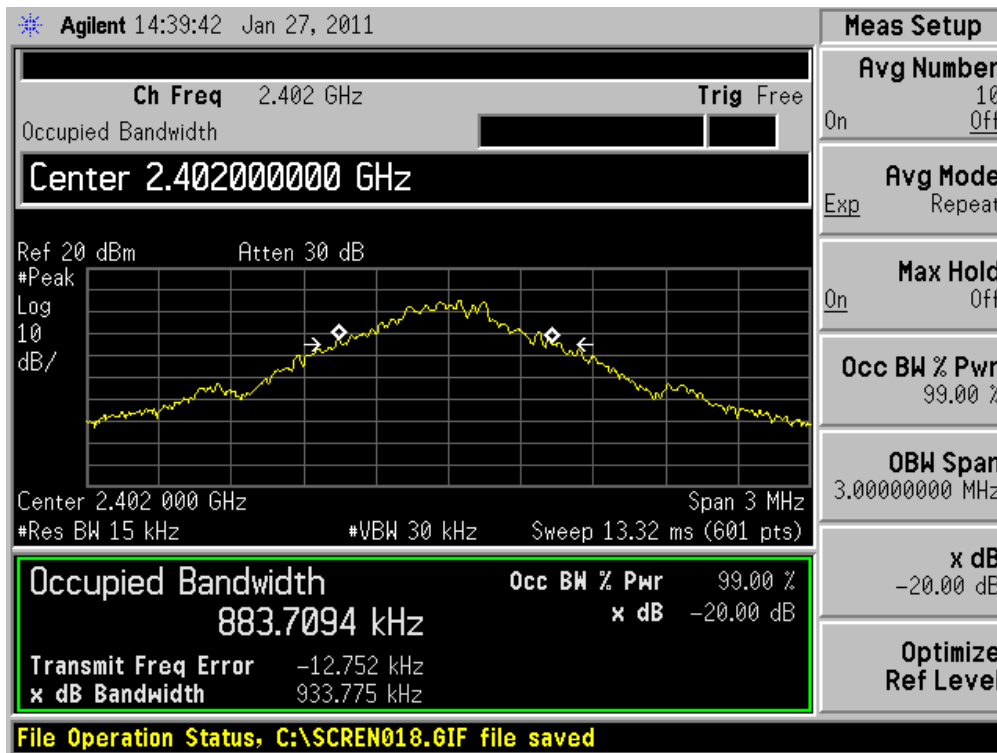

Carrier frequency (MHz): 2402

Channel No.:0

# TA Technology (Shanghai) Co., Ltd.

## Test Report

Registration Num:428261

Report No.: RZC1101-0124RF02

Page 16of 91

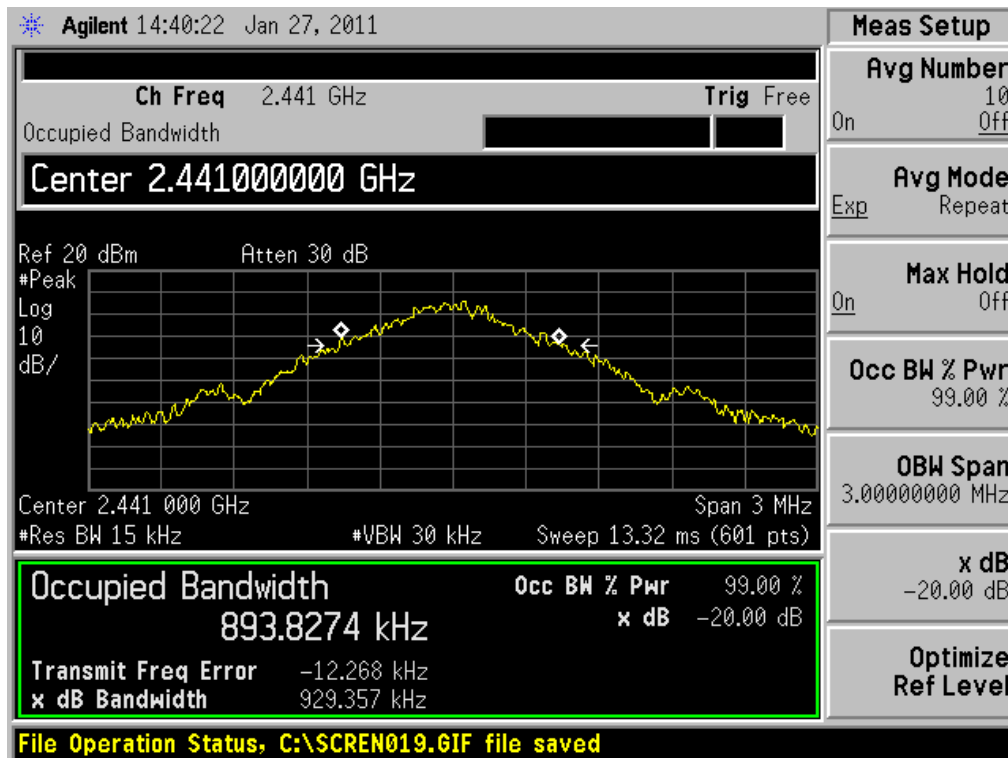

Carrier frequency (MHz): 2441

Channel No.:39

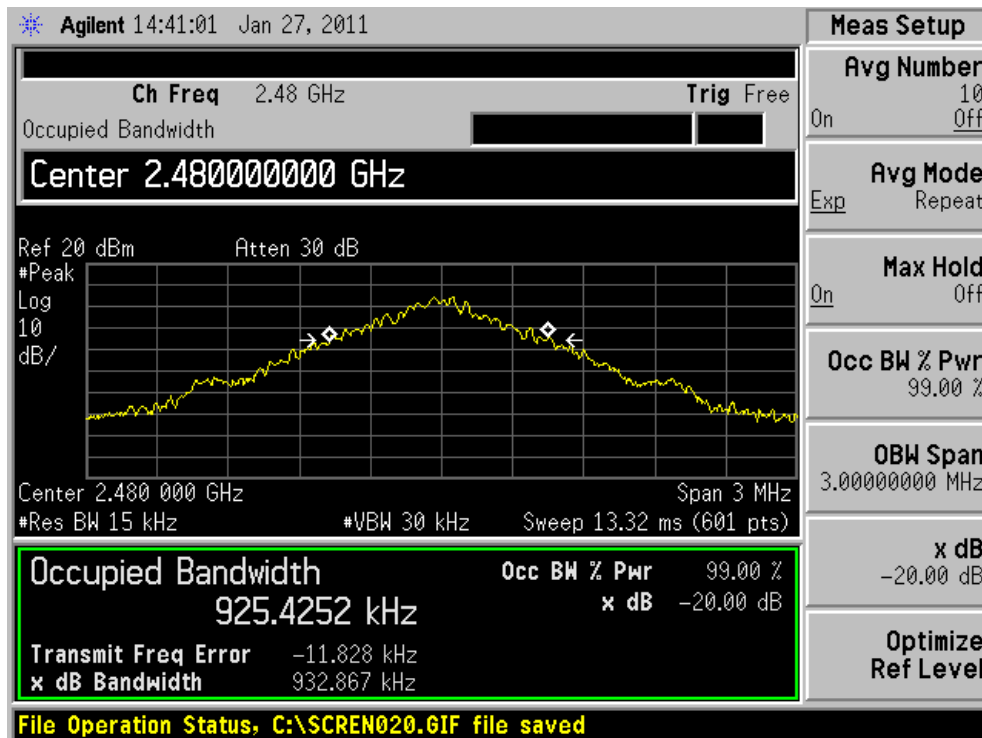

Carrier frequency (MHz): 2480

Channel No.:78

# TA Technology (Shanghai) Co., Ltd.

## Test Report

Registration Num:428261

Report No.: RZC1101-0124RF02

Page 17 of 91

3DH5

| Channel | Frequency (MHz) | 20dB Bandwidth (kHz) |
|---------|-----------------|----------------------|
| 0       | 2402            | 1295                 |
| 39      | 2441            | 1318                 |
| 78      | 2480            | 1275                 |

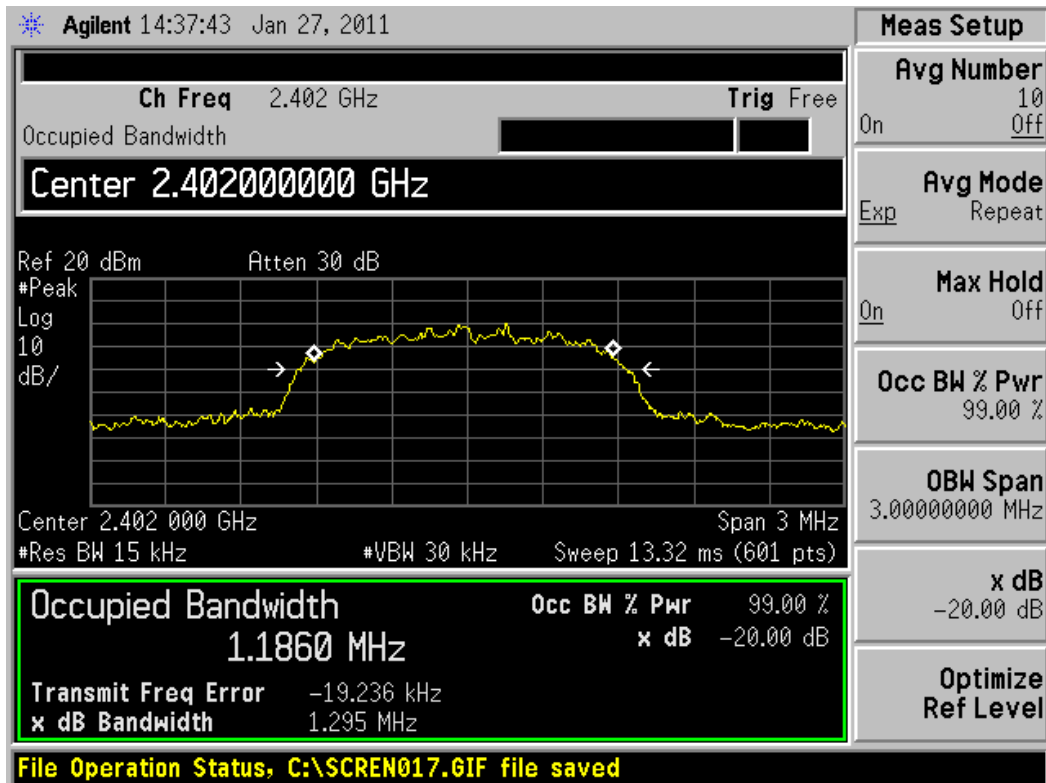

Carrier frequency (MHz): 2402

Channel No.:0

# TA Technology (Shanghai) Co., Ltd.

## Test Report

Registration Num:428261

Report No.: RZC1101-0124RF02

Page 18of 91

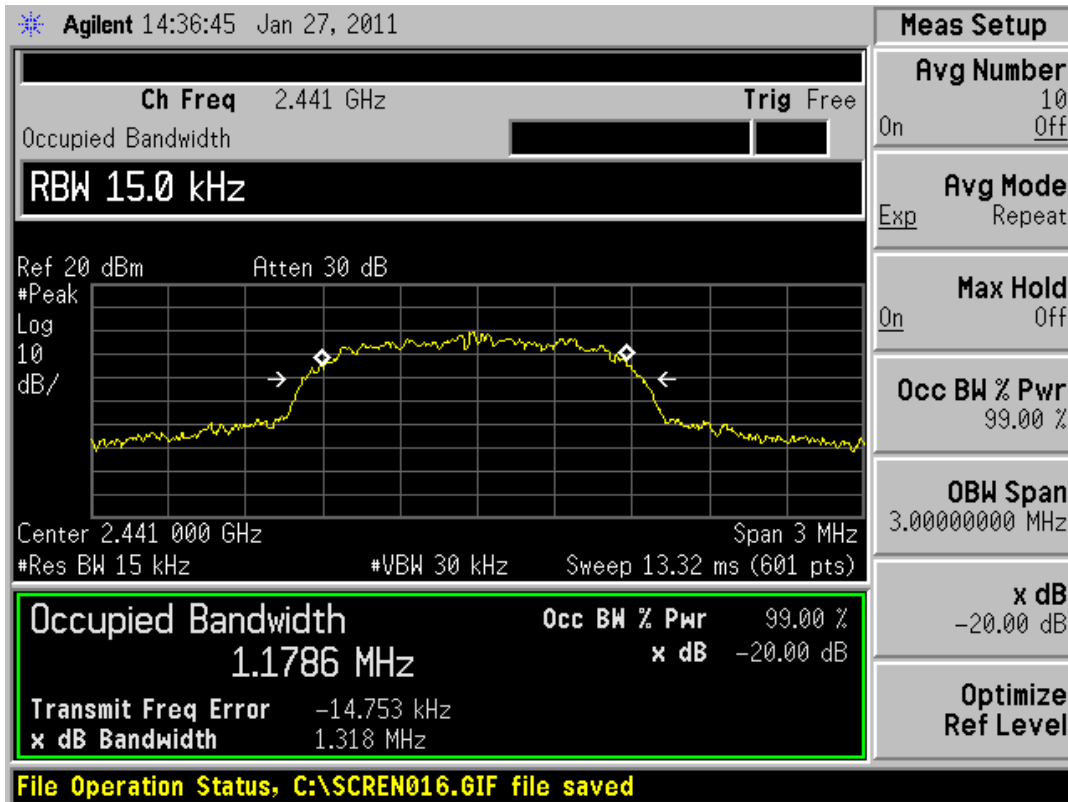

Carrier frequency (MHz): 2441

Channel No.:39

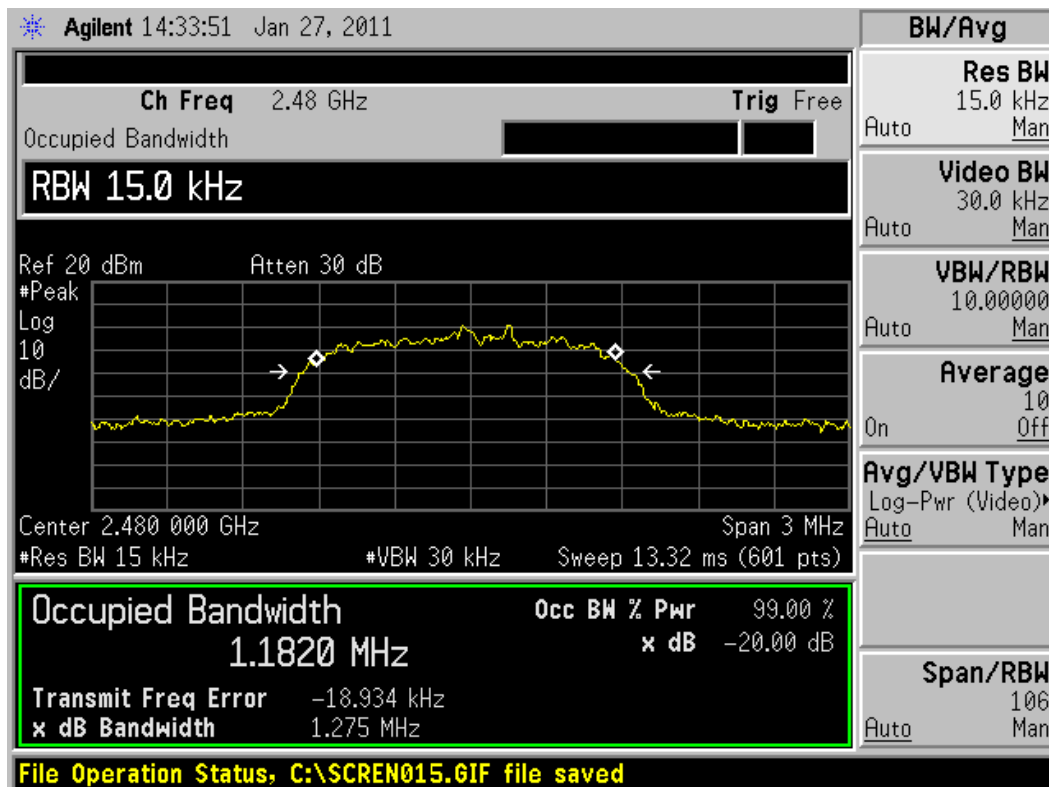

Carrier frequency (MHz): 2480

Channel No.:78

## 2.4. Frequency Separation

### Ambient condition

|             |                   |          |
|-------------|-------------------|----------|
| Temperature | Relative humidity | Pressure |
| 23°C ~25°C  | 45%~50%           | 101.5kPa |

### Method of Measurement

The Equipment Under Test (EUT) was set up in a shielded room to perform the spurious emissions measurements. The EUT was connected to the spectrum analyzer and Bluetooth test set via a power splitter with a known loss. RBW is set to 300kHz and VBW is set to 3MHz on spectrum analyzer. Set EUT on Hopping on mode.

### Test setup

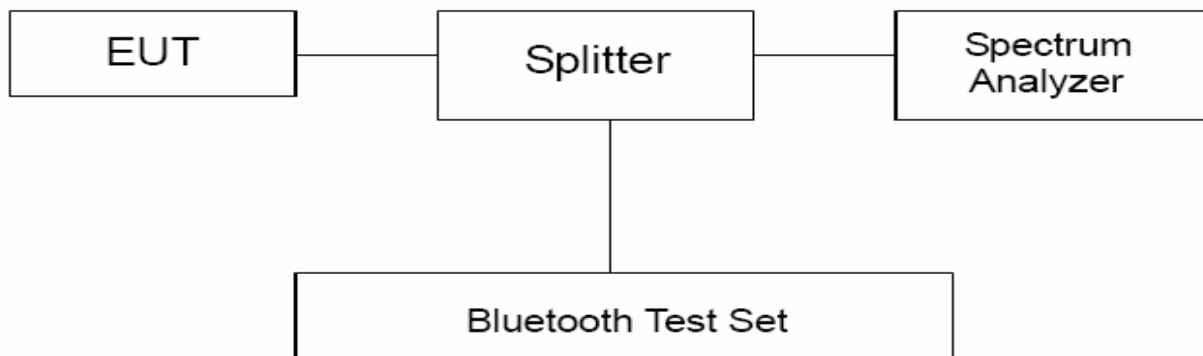

### Limits

Rule Part 15.247(a)(1) specifies that “Frequency hopping systems shall have hopping channel carrier frequencies separated by a minimum of 25 kHz or the 20 dB bandwidth of the hopping channel, whichever is greater. Alternatively, frequency hopping systems operating in the 2400–2483.5 MHz band may have hopping channel carrier frequencies that are separated by 25 kHz or two-thirds of the 20 dB bandwidth of the hopping channel, whichever is greater, provided the systems operate with an output power no greater than 125 mW. ”

### Measurement Uncertainty

The assessed measurement uncertainty to ensure 95% confidence level for the normal distribution is with the coverage factor  $k = 2$ .  $U = 936$  Hz.

Test Results:

DH5

| Carrier frequency (MHz) | Carrier frequency separation(kHz) | Limit(kHz) | Conclusion |
|-------------------------|-----------------------------------|------------|------------|
| 2402                    | 1005                              | 622.5167   | PASS       |
| 2441                    | 1005                              | 619.5713   | PASS       |
| 2480                    | 1055                              | 621.9113   | PASS       |

Note: Select the value of two-thirds of 20 dB bandwidth as the limit, since it is greater than 25 kHz.

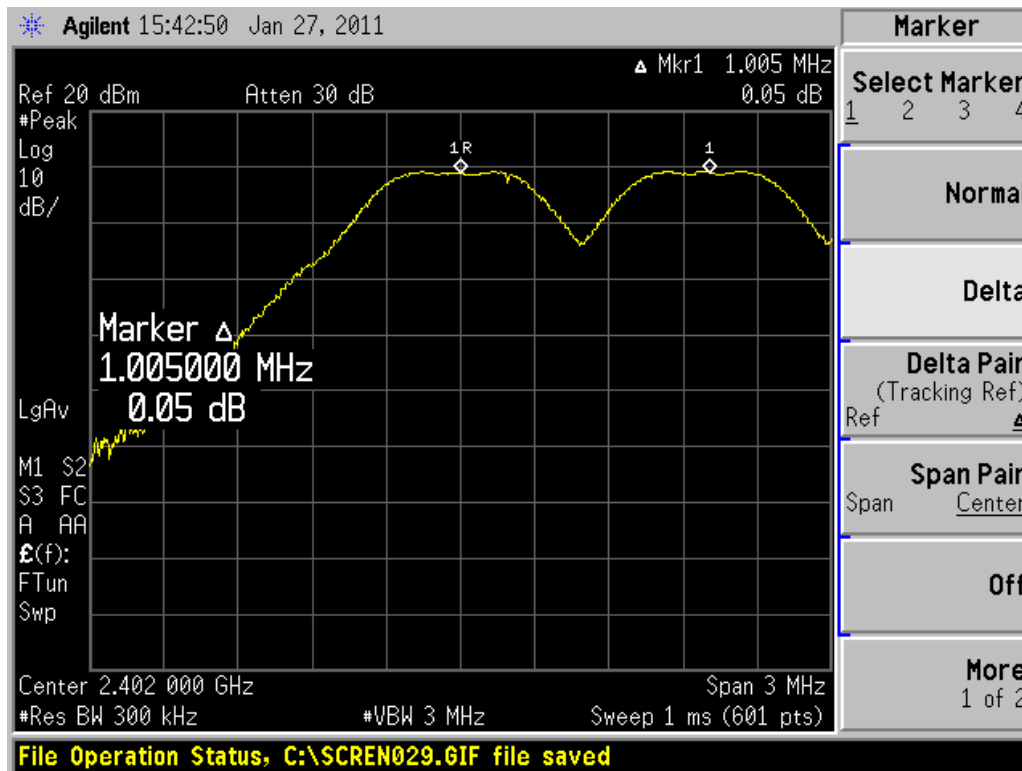

Carrier frequency (MHz): 2402

Channel No.:0

# TA Technology (Shanghai) Co., Ltd. Test Report

Registration Num:428261

Report No.: RZC1101-0124RF02

Page 21 of 91

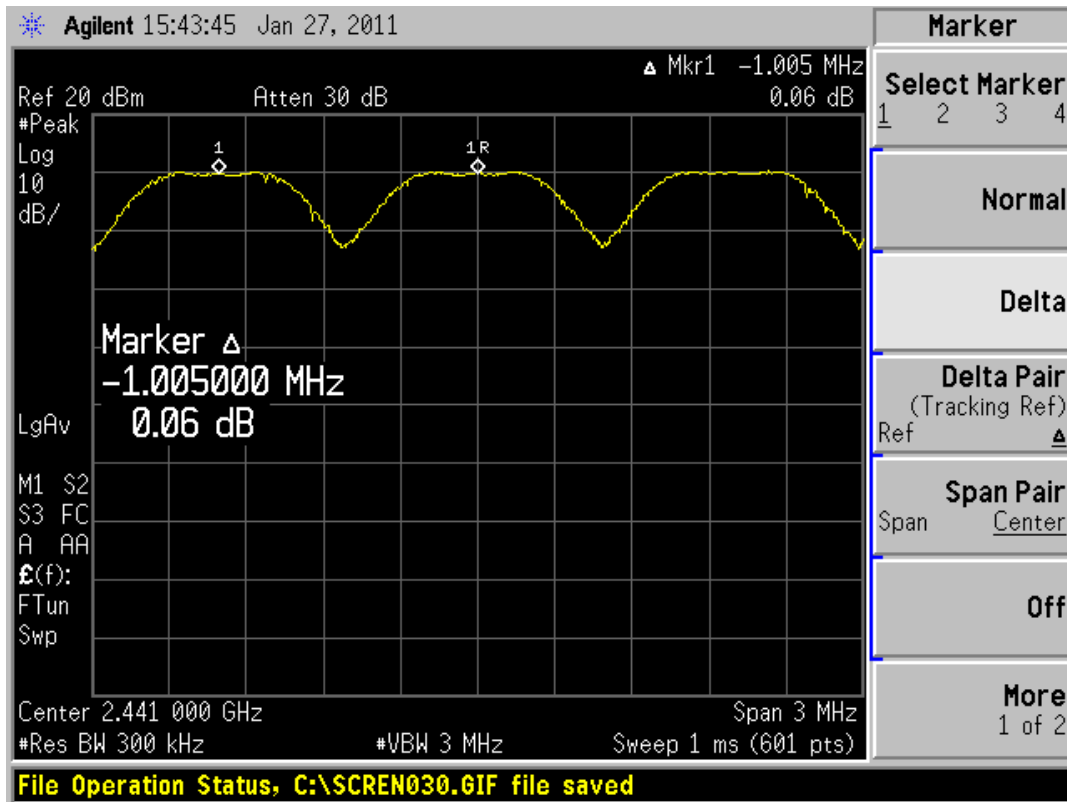

Carrier frequency (MHz): 2441

Channel No.:39

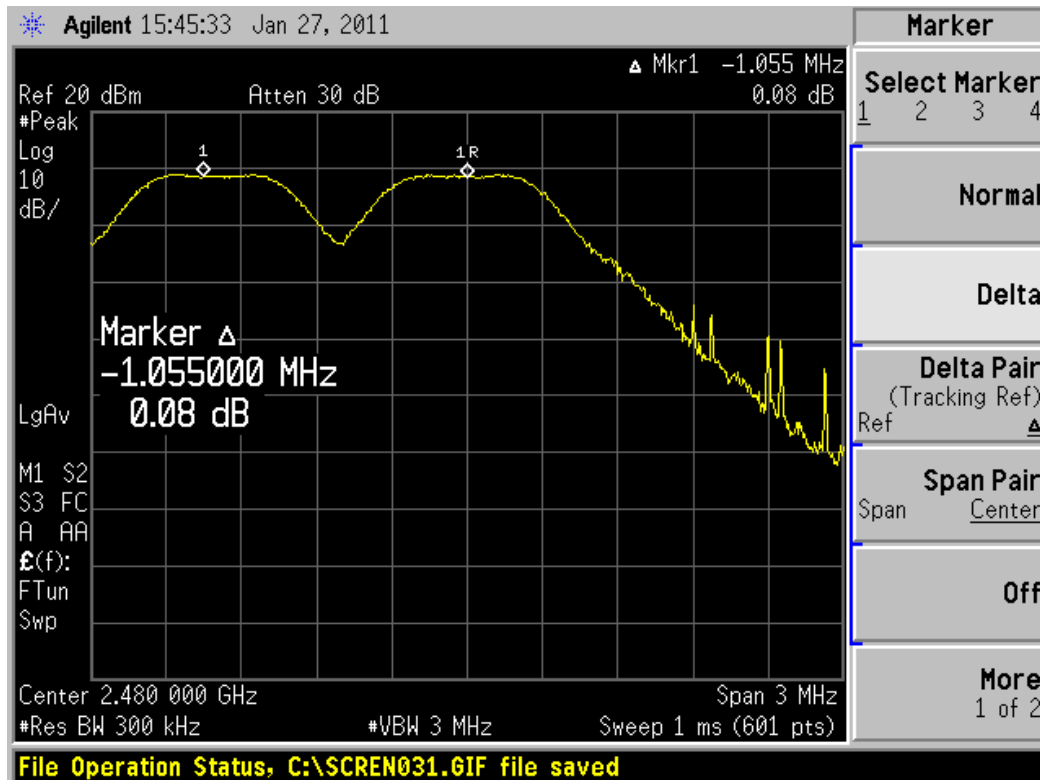

Carrier frequency (MHz): 2480

Channel No.:78

# TA Technology (Shanghai) Co., Ltd.

## Test Report

Registration Num:428261

Report No.: RZC1101-0124RF02

Page 22of 91

### 3DH5

| Carrier frequency (MHz) | Carrier frequency separation(kHz) | Limit(kHz) | Conclusion |
|-------------------------|-----------------------------------|------------|------------|
| 2402                    | 1115                              | 863.3333   | PASS       |
| 2441                    | 1000                              | 878.6667   | PASS       |
| 2480                    | 1035                              | 850        | PASS       |

Note: Select the value of two-thirds of 20 dB bandwidth as the limit,since it is greater than 25 kHz.

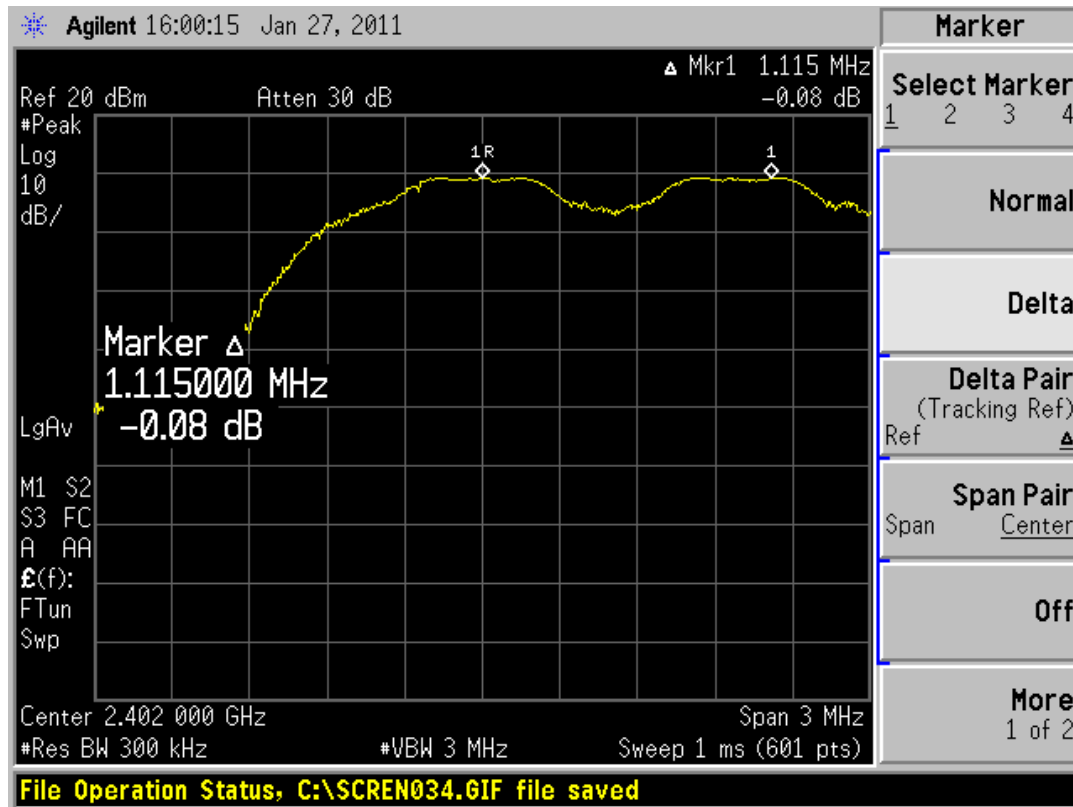

Carrier frequency (MHz): 2402

Channel No.:0

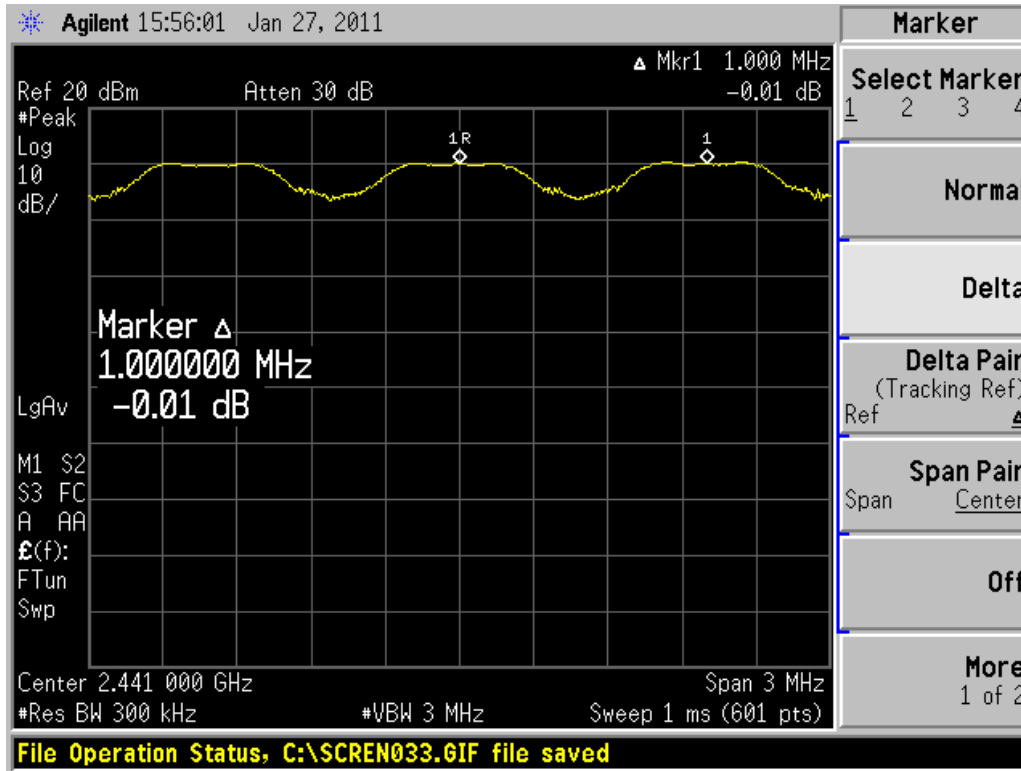

Carrier frequency (MHz): 2441

Channel No.:39

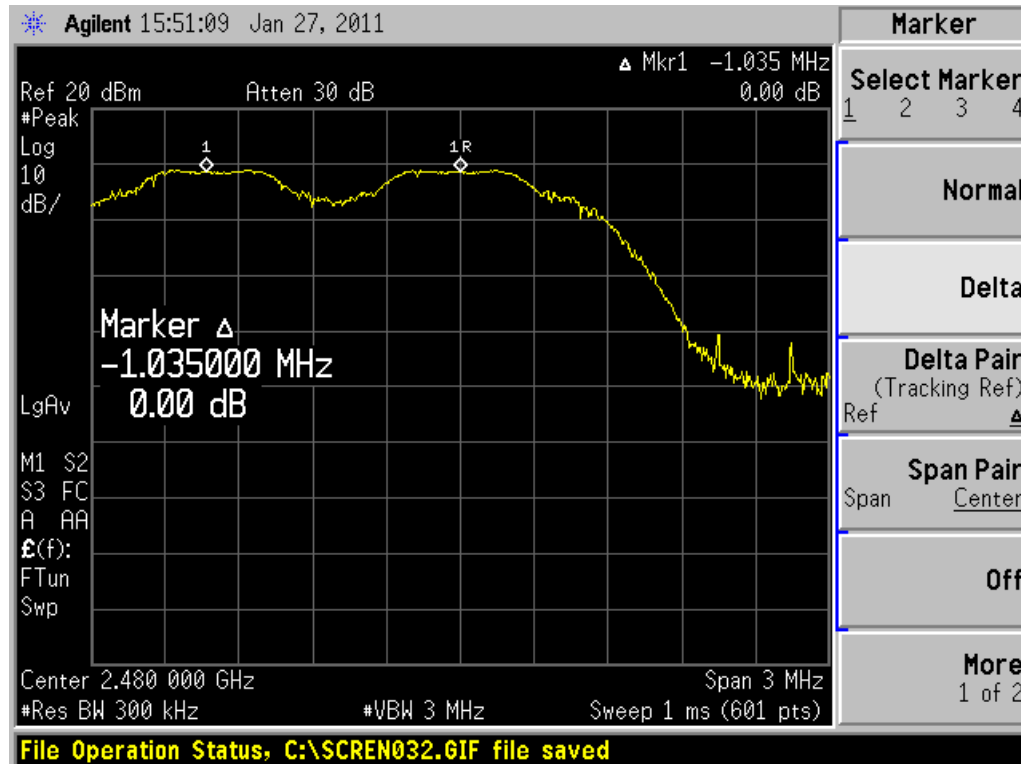

Carrier frequency (MHz): 2480

Channel No.:78

**TA Technology (Shanghai) Co., Ltd.**  
**Test Report**

Registration Num:428261

Report No.: RZC1101-0124RF02

Page 24of 91

## 2.5. Time of Occupancy (Dwell Time)

### Ambient condition

|             |                   |          |
|-------------|-------------------|----------|
| Temperature | Relative humidity | Pressure |
| 23°C ~25°C  | 45%~50%           | 101.5kPa |

### Methods of Measurement

The Equipment Under Test (EUT) was set up in a shielded room to perform the dwell time measurements. The EUT was connected to the spectrum analyzer and Bluetooth test set via a power splitter with a known loss. RBW is set to 1MHz and VBW is set to 3MHz on spectrum analyzer. The time slot length is measured of three different packet types, which are available in the Bluetooth technology. Those are DH1, DH3 and DH5 packets. The dwell time is calculated by:

Dwell time = time slot length \* hop rate \* 0.4s with:

- hop rate=1600 \* 1/s for DH1 packet =1600
- hop rate=1600/3 \* 1/s for DH3 packet =533.33
- hop rate=1600/5 \* 1/s for DH5 packet =320

### Test Setup

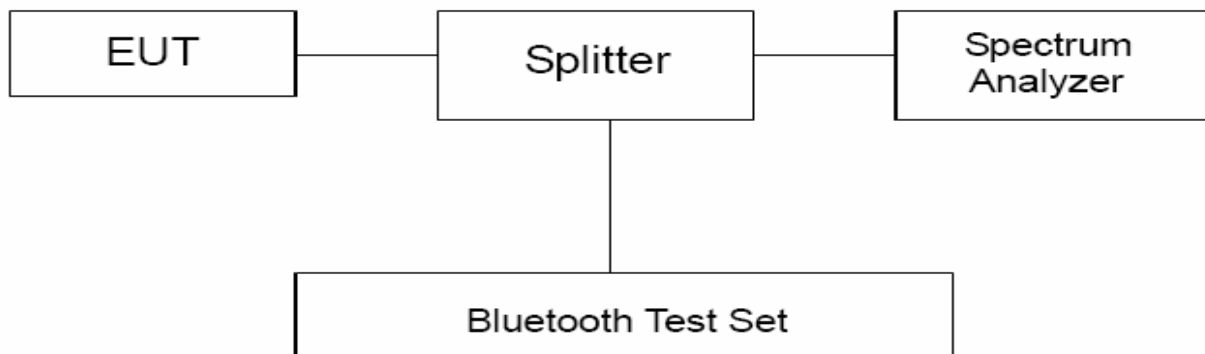

### Limits

Rule Part 22.913(a) specifies that " Frequency hopping systems in the 2400–2483.5 MHz band shall use at least 15 channels. The average time of occupancy on any channel shall not be greater than 0.4 seconds within a period of 0.4 seconds multiplied by the number of hopping channels employed.."

|            |         |
|------------|---------|
| Dwell time | ≤ 400ms |
|------------|---------|

### Measurement Uncertainty

The assessed measurement uncertainty to ensure 95% confidence level for the normal distribution is with the coverage factor  $k = 2$ .  $U_{DH1} = 0.64\text{ms}$ ,  $U_{DH3} = 0.80\text{ms}$ ,  $U_{DH5} = 0.70\text{ms}$ .

# TA Technology (Shanghai) Co., Ltd. Test Report

Registration Num:428261

Report No.: RZC1101-0124RF02

Page 25 of 91

## Test Results:

CH 39

| Packet type | hop rate (1/s) | Time slot length(ms) | Dwell time (ms) | Limit (ms) | Conclusion |
|-------------|----------------|----------------------|-----------------|------------|------------|
| DH1         | 1600           | 0.3833               | 245.312         | 400        | PASS       |
| DH3         | 533.33         | 1.65                 | 351.9978        | 400        | PASS       |
| DH5         | 320            | 2.883                | 369.024         | 400        | PASS       |
| 3DH1        | 1600           | 0.4                  | 256             | 400        | PASS       |
| 3DH3        | 533.33         | 1.65                 | 351.9978        | 400        | PASS       |
| 3DH5        | 320            | 2.9                  | 371.2           | 400        | PASS       |

Note: Dwell time = time slot length \* hop rate \* 0.4s

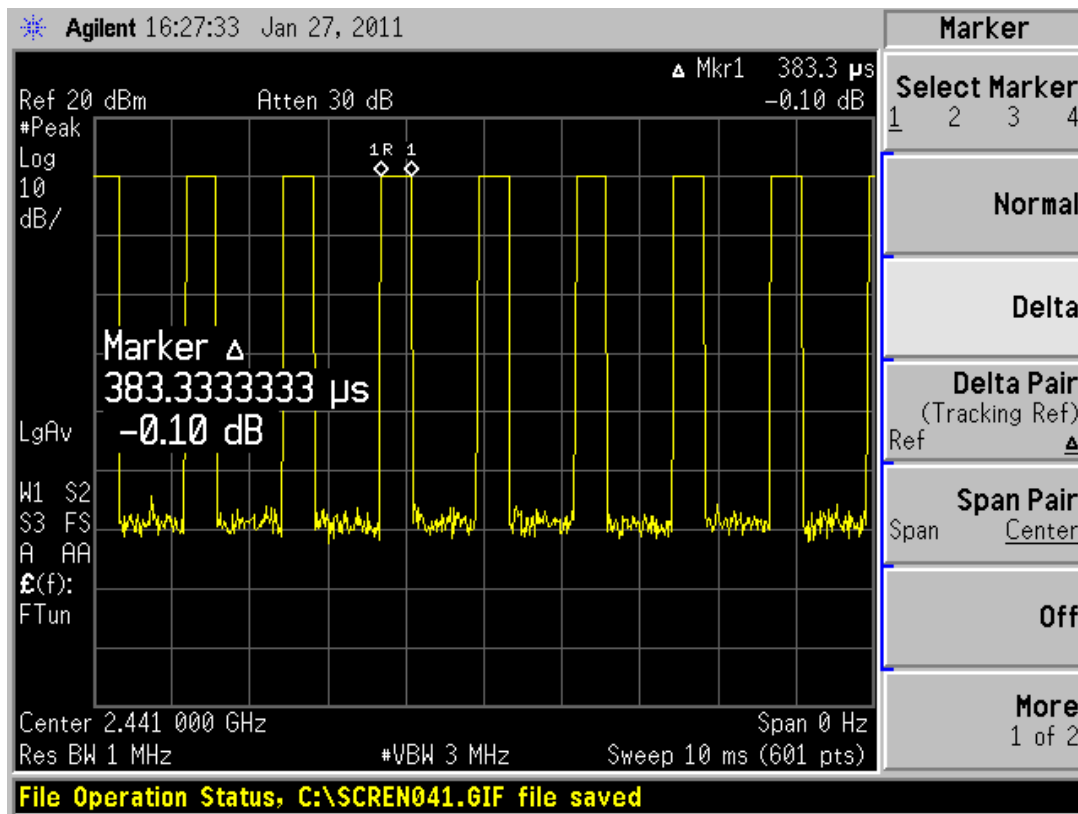

Carrier frequency (MHz): 2441,DH1

# TA Technology (Shanghai) Co., Ltd. Test Report

Registration Num:428261

Report No.: RZC1101-0124RF02

Page 26of 91

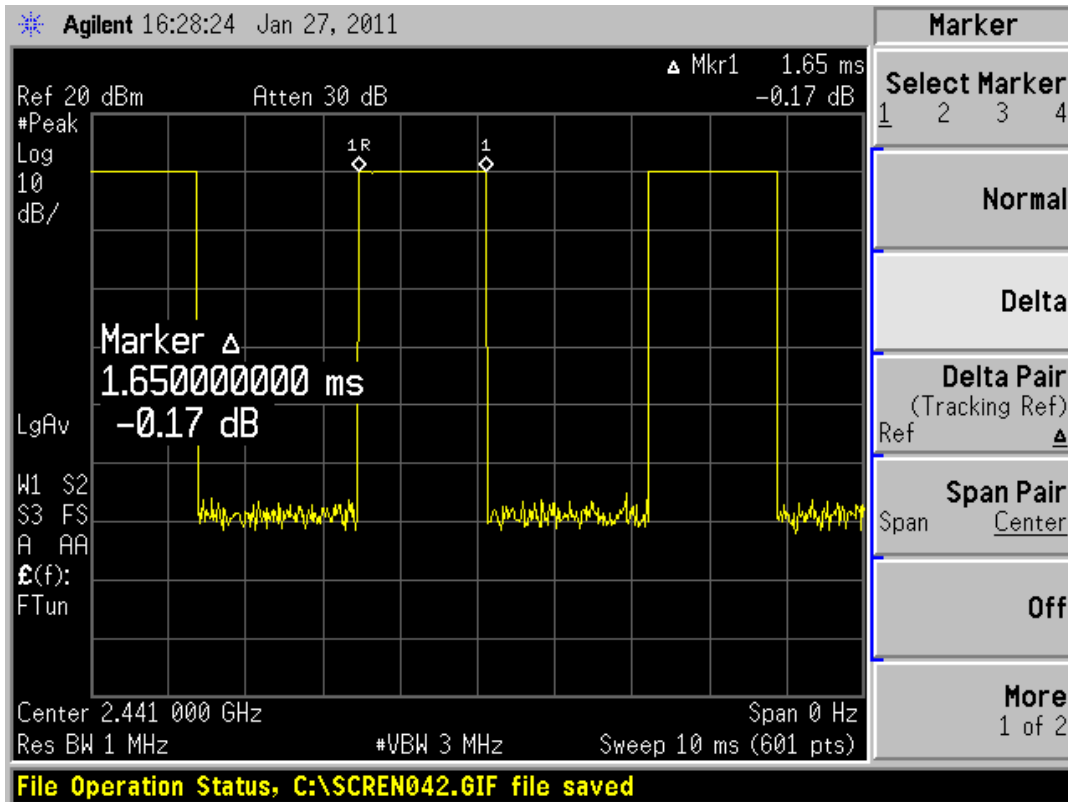

Carrier frequency (MHz): 2441,DH3

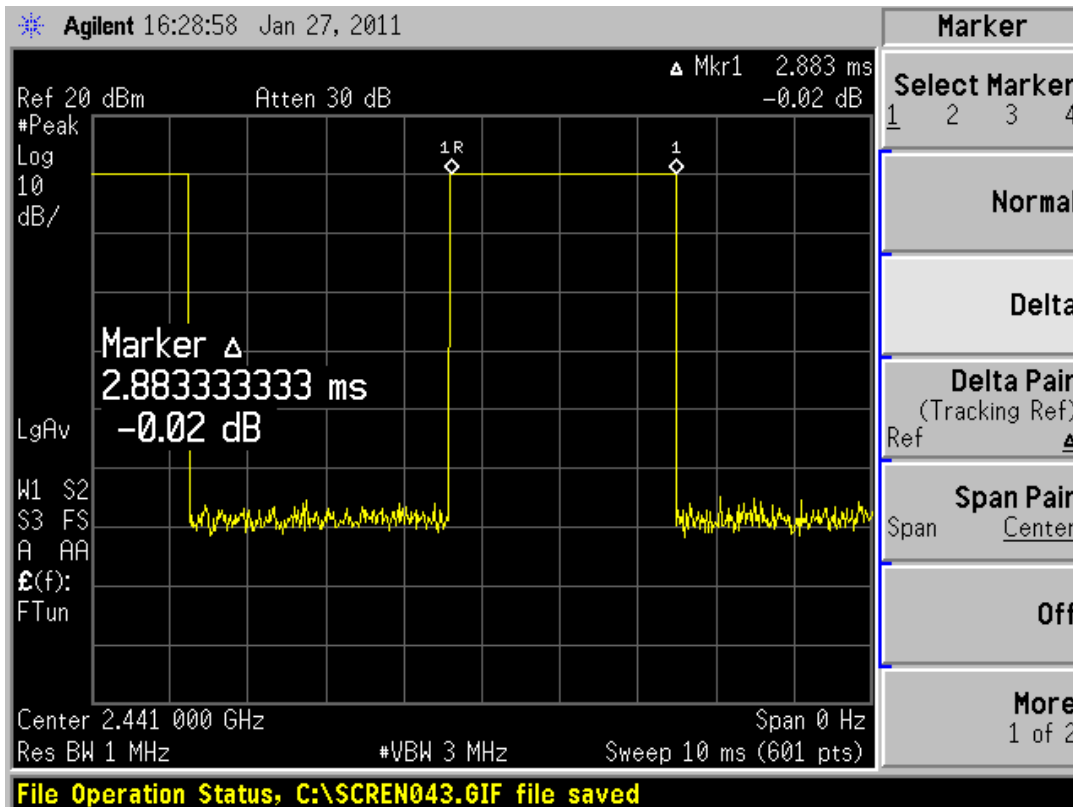

Carrier frequency (MHz): 2441,DH5

# TA Technology (Shanghai) Co., Ltd. Test Report

Registration Num:428261

Report No.: RZC1101-0124RF02

Page 27 of 91

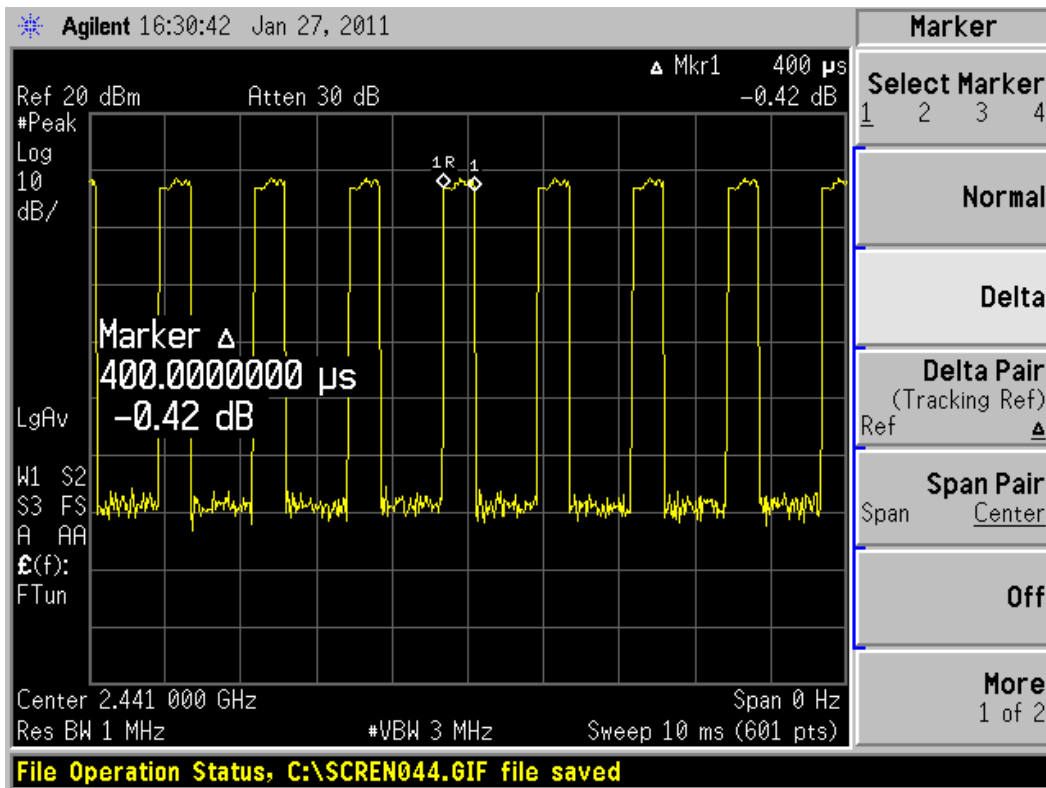

Carrier frequency (MHz): 2441,3DH1

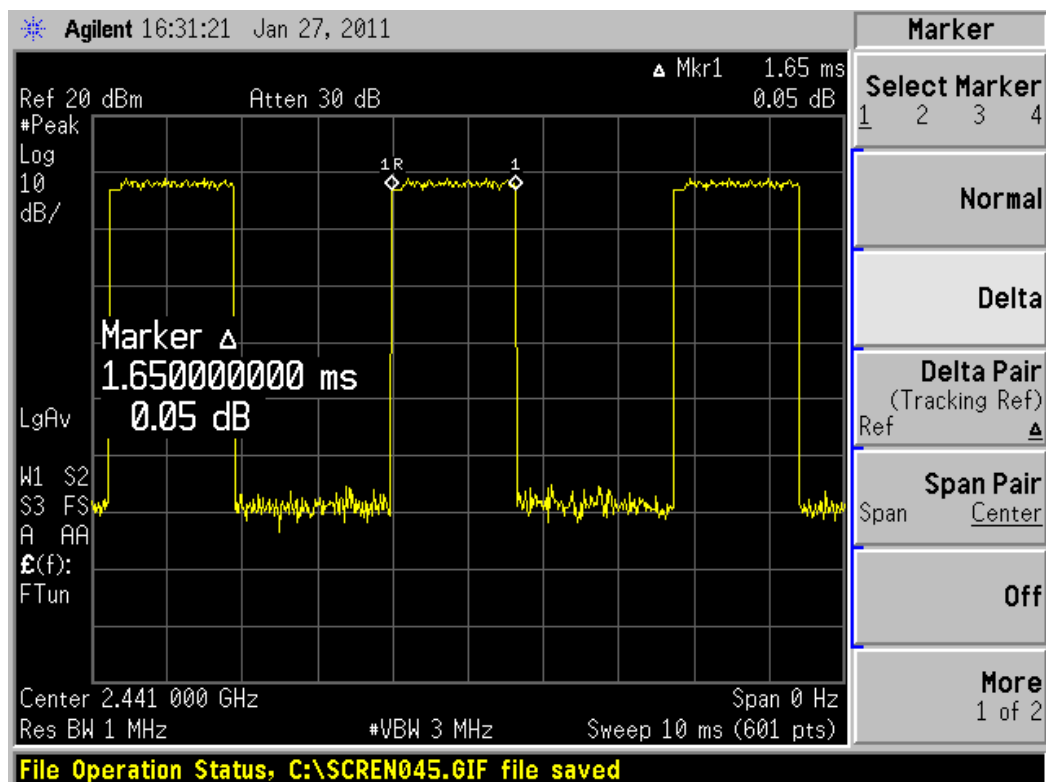

Carrier frequency (MHz): 2441,3DH3

TA Technology (Shanghai) Co., Ltd.  
Test Report

Registration Num:428261

Report No.: RZC1101-0124RF02

Page 28of 91

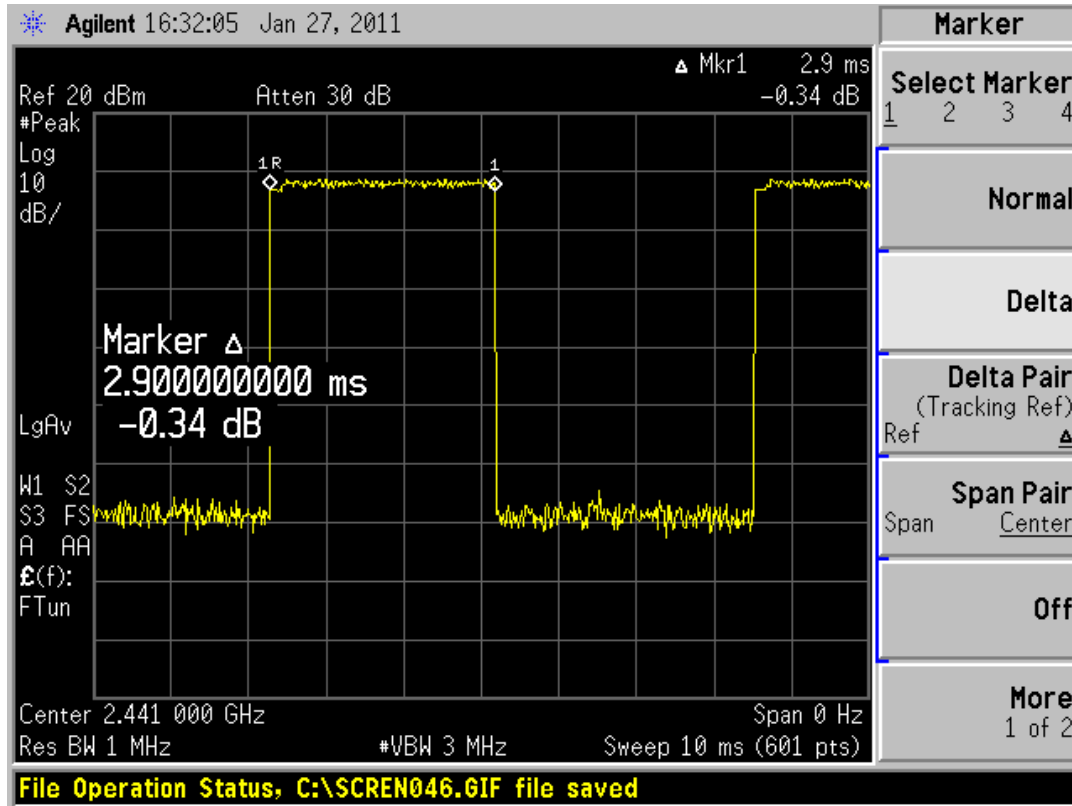

Carrier frequency (MHz): 2441,3DH5

## 2.6. Band Edge Compliance

### Ambient condition

|             |                   |          |
|-------------|-------------------|----------|
| Temperature | Relative humidity | Pressure |
| 23°C ~25°C  | 45%~50%           | 101.5kPa |

### Method of Measurement

The Equipment Under Test (EUT) was set up in a shielded room to perform the spurious emissions measurements. The EUT was connected to the spectrum analyzer and Bluetooth test set via a power splitter with a known loss. The band edge of the lowest and highest channels were measured. The peak detector is used. RBW is set to 1MHz and VBW is set to 3MHz on spectrum analyzer. Spectrum analyzer plots are included on the following pages. EUT test for Hopping On mode and Hopping Off mode.

### Test Setup

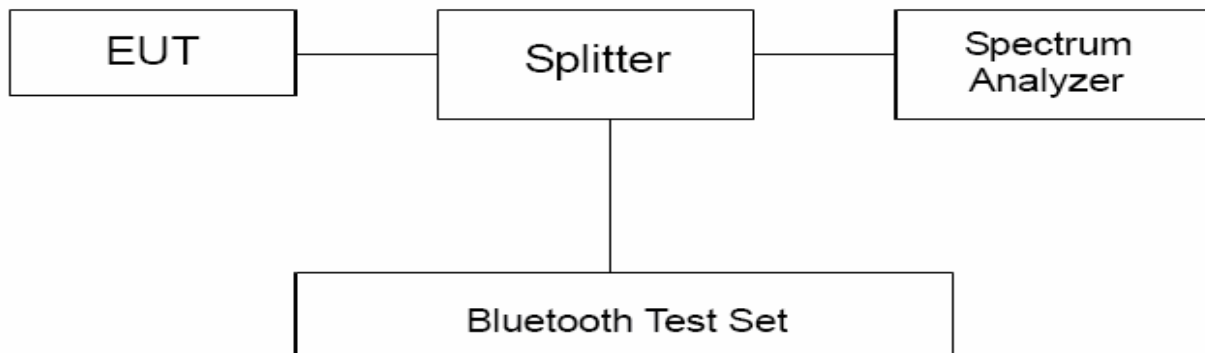

### Limits

Rule Part 15.247(d) specifies that “In any 100 kHz bandwidth outside the frequency band in which the spread spectrum or digitally modulated intentional radiator is operating, the radio frequency power that is produced by the intentional radiator shall be at least 20 dB below that in the 100 kHz bandwidth within the band that contains the highest level of the desired power, based on either an RF conducted or a radiated measurement, provided the transmitter demonstrates compliance with the peak conducted power limits.”

|       |              |
|-------|--------------|
| Limit | $\geq 20$ dB |
|-------|--------------|

### Measurement Uncertainty

The assessed measurement uncertainty to ensure 95% confidence level for the normal distribution is with the coverage factor  $k = 1.96$ .

|           |             |
|-----------|-------------|
| Frequency | Uncertainty |
| 2GHz-3GHz | 1.407 dB    |

# TA Technology (Shanghai) Co., Ltd. Test Report

Registration Num:428261

Report No.: RZC1101-0124RF02

Page 30 of 91

**Test Results: PASS**

**Hopping On-DH5-**

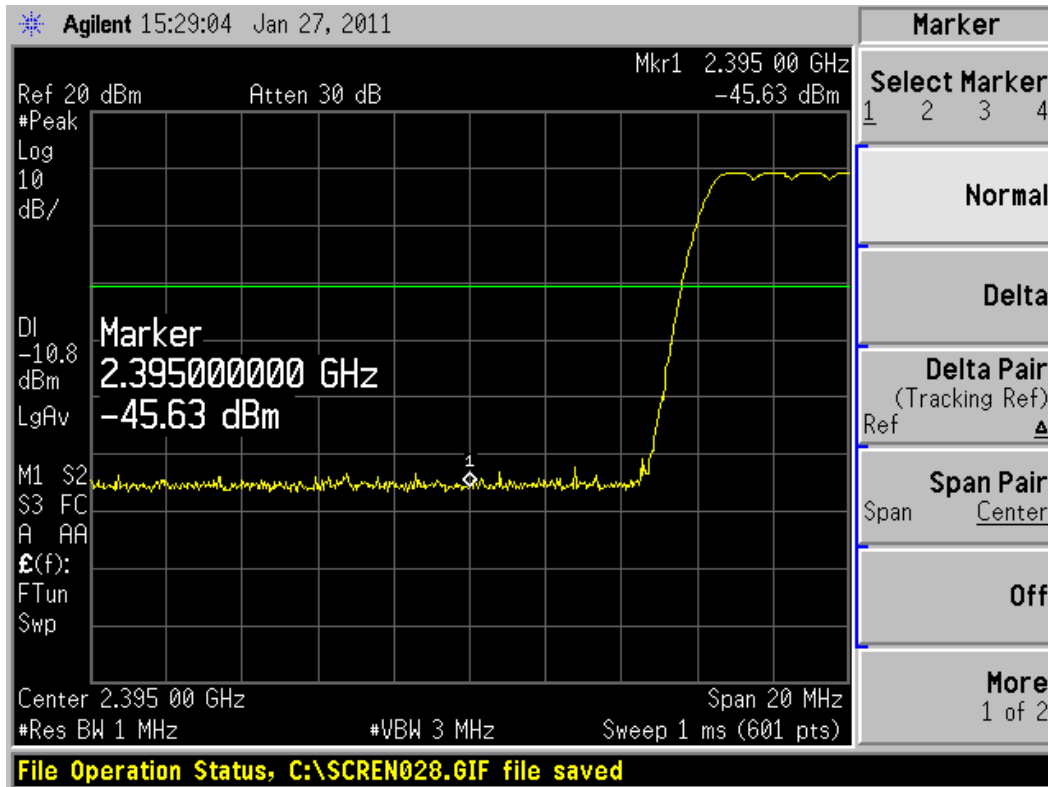

Carrier frequency (MHz): 2402

Channel No.:0

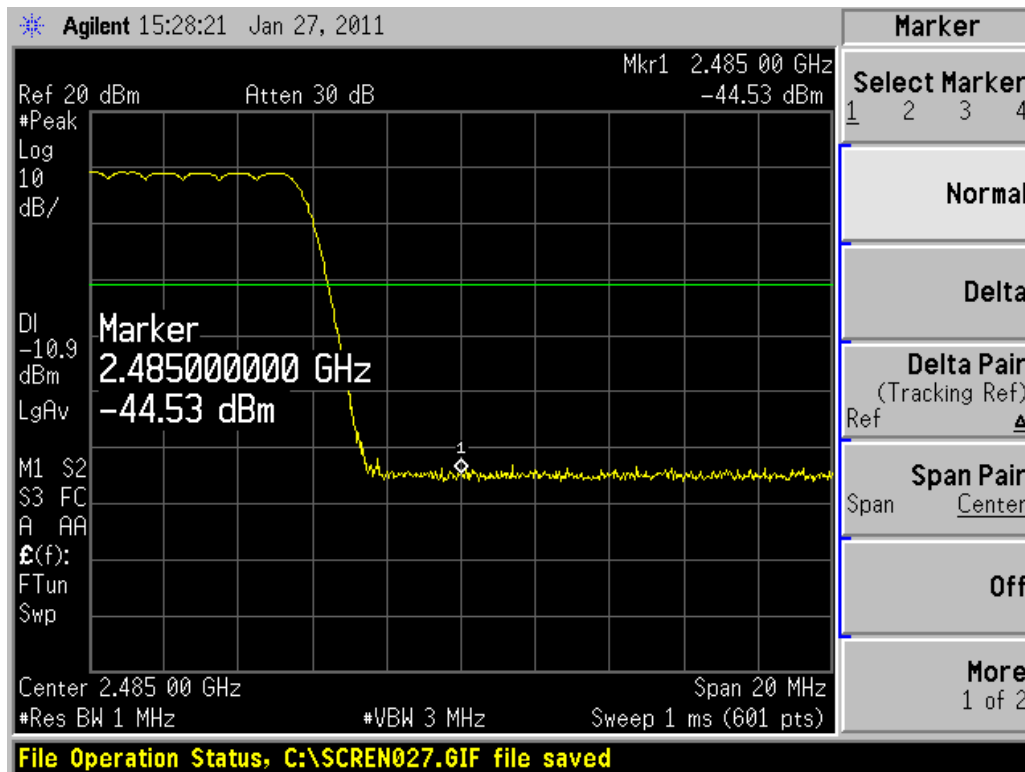

Carrier frequency (MHz): 2480

Channel No.:78

Hopping On-3DH5

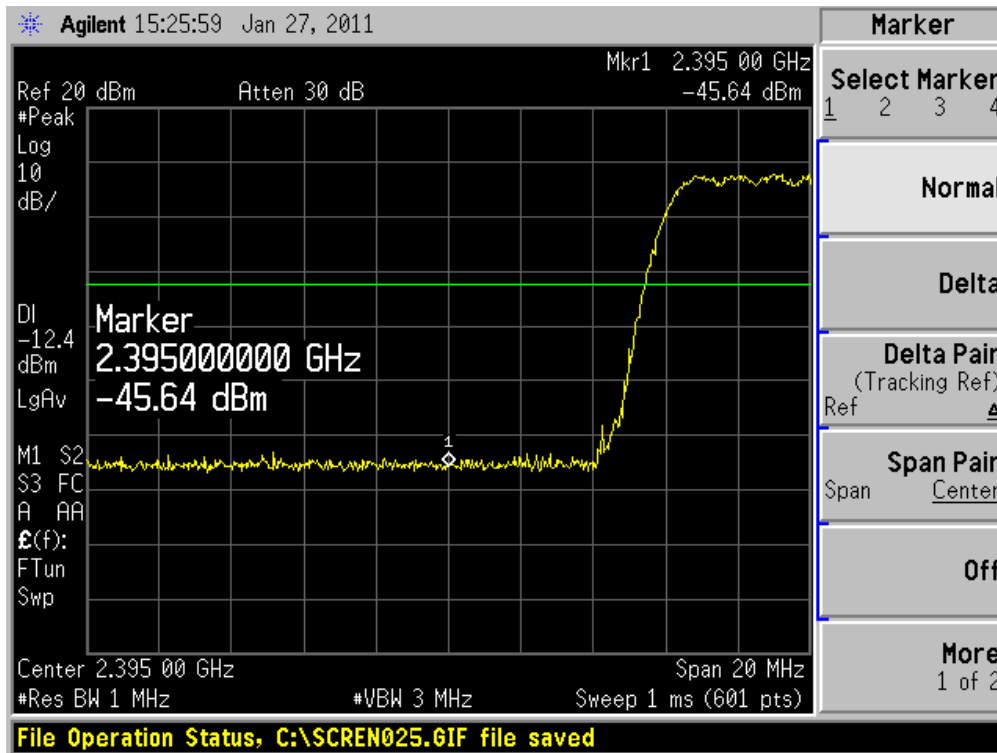

Carrier frequency (MHz): 2402

Channel No.:0

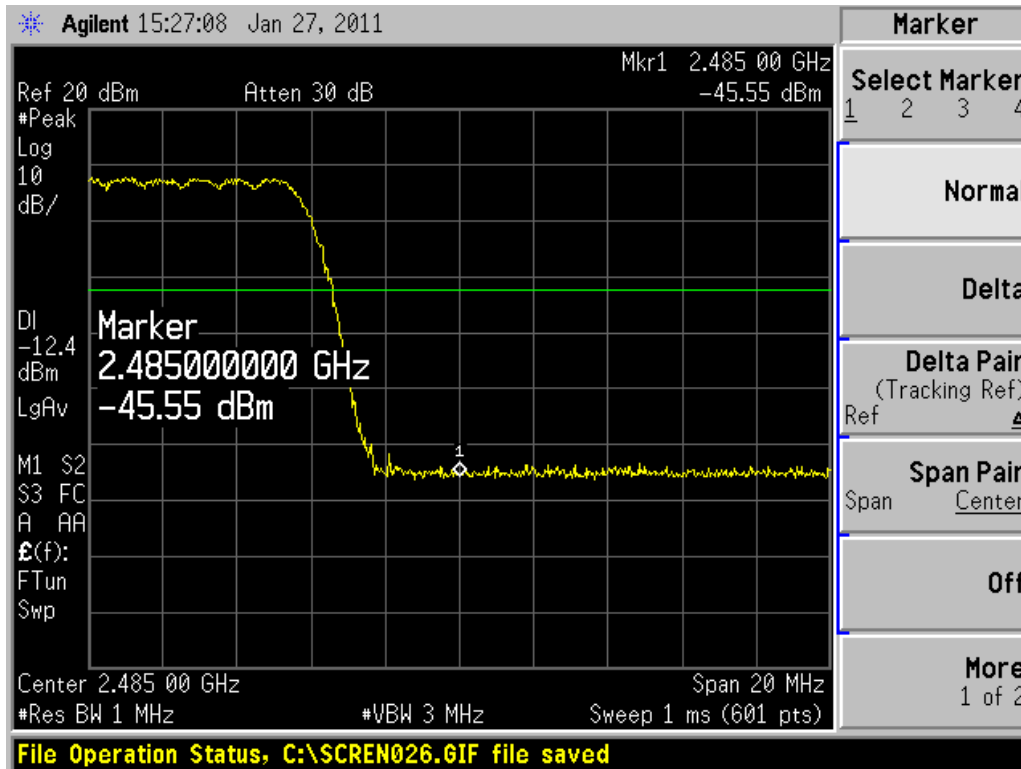

Carrier frequency (MHz): 2480

Channel No.:78

# TA Technology (Shanghai) Co., Ltd. Test Report

Registration Num:428261

Report No.: RZC1101-0124RF02

Page 32 of 91

## Hopping Off-DH5-

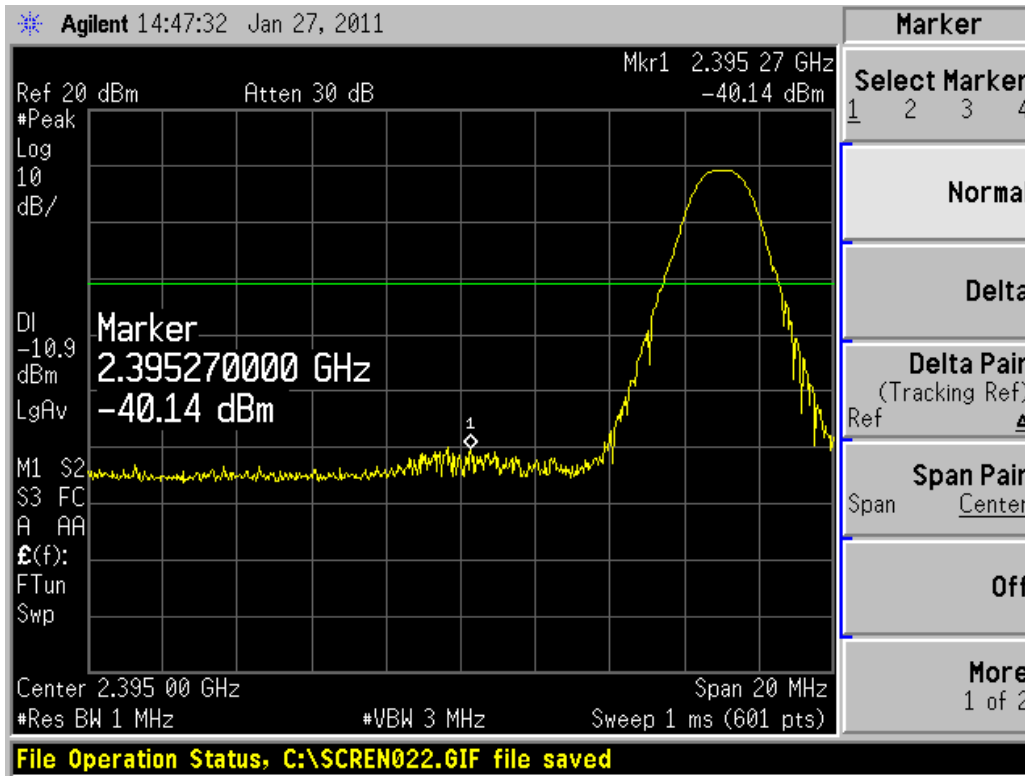

Carrier frequency (MHz): 2402

Channel No.:0

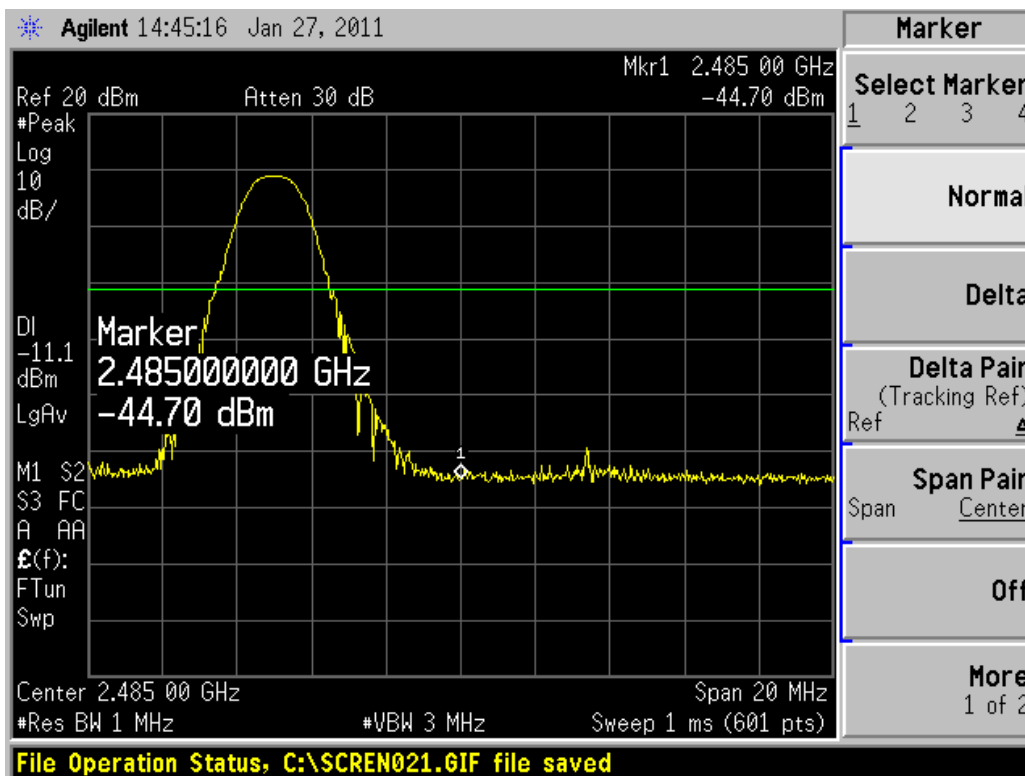

Carrier frequency (MHz): 2480

Channel No.:78

# TA Technology (Shanghai) Co., Ltd. Test Report

Registration Num:428261

Report No.: RZC1101-0124RF02

Page 33of 91

## Hopping Off-3DH5

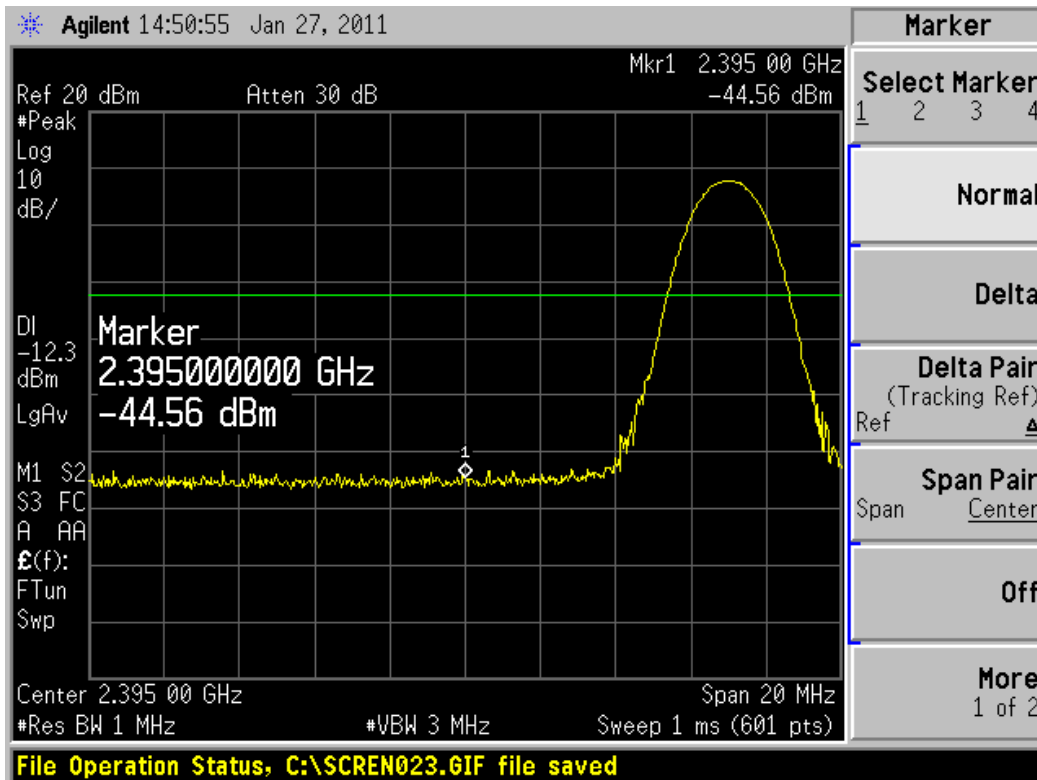

Carrier frequency (MHz): 2402

Channel No.:0

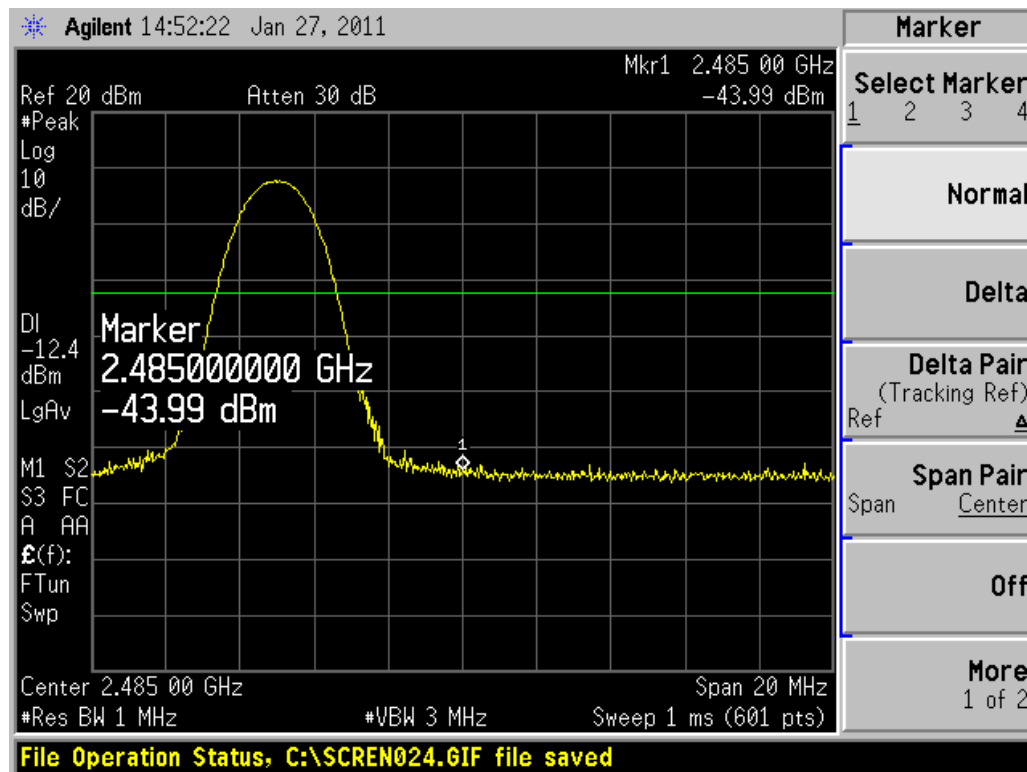

Carrier frequency (MHz): 2480

Channel No.:78

## 2.7. Spurious Radiated Emissions in the Restricted Band

### Ambient condition

| Temperature | Relative humidity | Pressure |
|-------------|-------------------|----------|
| 23°C ~25°C  | 45%~50%           | 101.5kPa |

The Equipment Under Test (EUT) was set up on a non-conductive table in the semi-anechoic chamber. The test was performed at the distance of 3 m between the EUT and the receiving antenna. The turntable shall be rotated from 0 to 360 degrees for detecting the maximum of radiated spurious signal level. The measurements shall be repeated with orthogonal polarization of the test antenna. The data of cable loss and antenna factor has been calibrated in full testing frequency range before the testing.

Set the spectrum analyzer in the following:

- (a) PEAK: RBW=VBW=1MHz / Sweep=AUTO
- (b) AVERAGE: RBW=1MHz / VBW=10Hz / Sweep=AUTO

This setting method can refer to DA00-705.

The field strength of spurious emission was measured in the following position: EUT stand-up position (Z axis), lie-down position (X, Y axis) and docking mode. The worst emission was found in stand-up position (Z axis) and the worst case was recorded.

The test is in transmit mode.

### Test setup

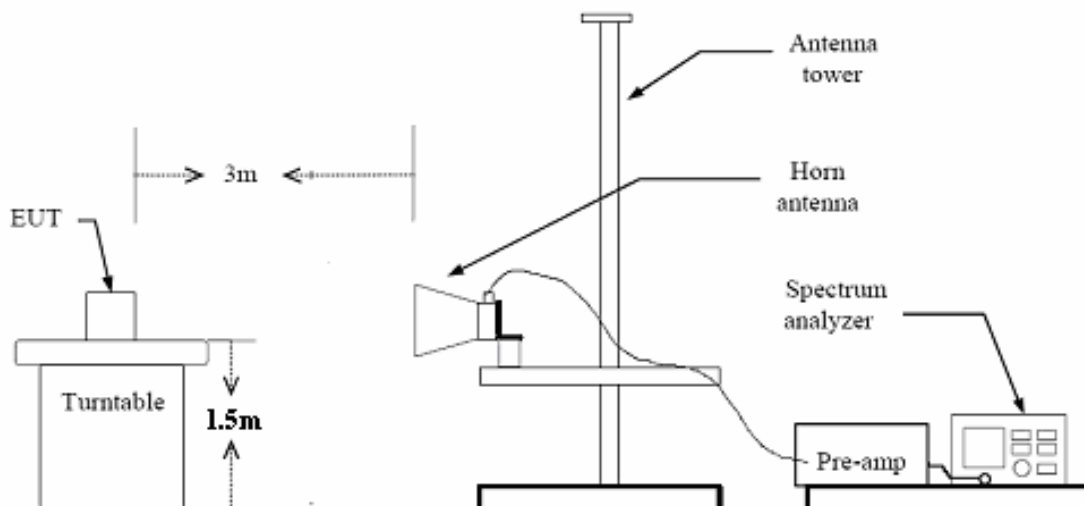

# TA Technology (Shanghai) Co., Ltd.

## Test Report

Registration Num:428261

Report No.: RZC1101-0124RF02

Page 35 of 91

### Limits

Spurious Radiated Emissions are permitted in any of the frequency bands listed below:

| MHz                        | MHz                   | MHz             | GHz              |
|----------------------------|-----------------------|-----------------|------------------|
| 0.090 - 0.110              | 16.42 - 16.423        | 399.9 - 410     | 4.5 - 5.15       |
| <sup>1</sup> 0.495 - 0.505 | 16.69475 - 16.69525   | 608 - 614       | 5.35 - 5.46      |
| 2.1735 - 2.1905            | 16.80425 - 16.80475   | 960 - 1240      | 7.25 - 7.75      |
| 4.125 - 4.128              | 25.5 - 25.67          | 1300 - 1427     | 8.025 - 8.5      |
| 4.17725 - 4.17775          | 37.5 - 38.25          | 1435 - 1626.5   | 9.0 - 9.2        |
| 4.20725 - 4.20775          | 73 - 74.6             | 1645.5 - 1646.5 | 9.3 - 9.5        |
| 6.215 - 6.218              | 74.8 - 75.2           | 1660 - 1710     | 10.6 - 12.7      |
| 6.26775 - 6.26825          | 108 - 121.94          | 1718.8 - 1722.2 | 13.25 - 13.4     |
| 6.31175 - 6.31225          | 123 - 138             | 2200 - 2300     | 14.47 - 14.5     |
| 8.291 - 8.294              | 149.9 - 150.05        | 2310 - 2390     | 15.35 - 16.2     |
| 8.362 - 8.366              | 156.52475 - 156.52525 | 2483.5 - 2500   | 17.7 - 21.4      |
| 8.37625 - 8.38675          | 156.7 - 156.9         | 2690 - 2900     | 22.01 - 23.12    |
| 8.41425 - 8.41475          | 162.0125 - 167.17     | 3260 - 3267     | 23.6 - 24.0      |
| 12.29 - 12.293             | 167.72 - 173.2        | 3332 - 3339     | 31.2 - 31.8      |
| 12.51975 - 12.52025        | 240 - 285             | 3345.8 - 3358   | 36.43 - 36.5     |
| 12.57675 - 12.57725        | 322 - 335.4           | 3600 - 4400     | ( <sup>2</sup> ) |
| 13.36 - 13.41              |                       |                 |                  |

Limit in restricted band

| Frequency of emission (MHz) | Field strength(uV/m) | Field strength(dBuV/m) |
|-----------------------------|----------------------|------------------------|
| 30-88                       | 100                  | 40                     |
| 88-216                      | 150                  | 43.5                   |
| 216-960                     | 200                  | 46                     |
| Above960                    | 500                  | 54                     |

§15.35(b)

There is also a limit on the radio frequency emissions, as measured using instrumentation with a peak detector function, corresponding to 20 dB above the maximum permitted average limit.

Peak Limit=74 dBuV/m

Average Limit=54 dBuV/m

### Measurement Uncertainty

The assessed measurement uncertainty to ensure 95% confidence level for the normal distribution is with the coverage factor  $k = 1.96$ .  $U=3.92$  dB.

Test Results:

Basic Rate- Channel 0

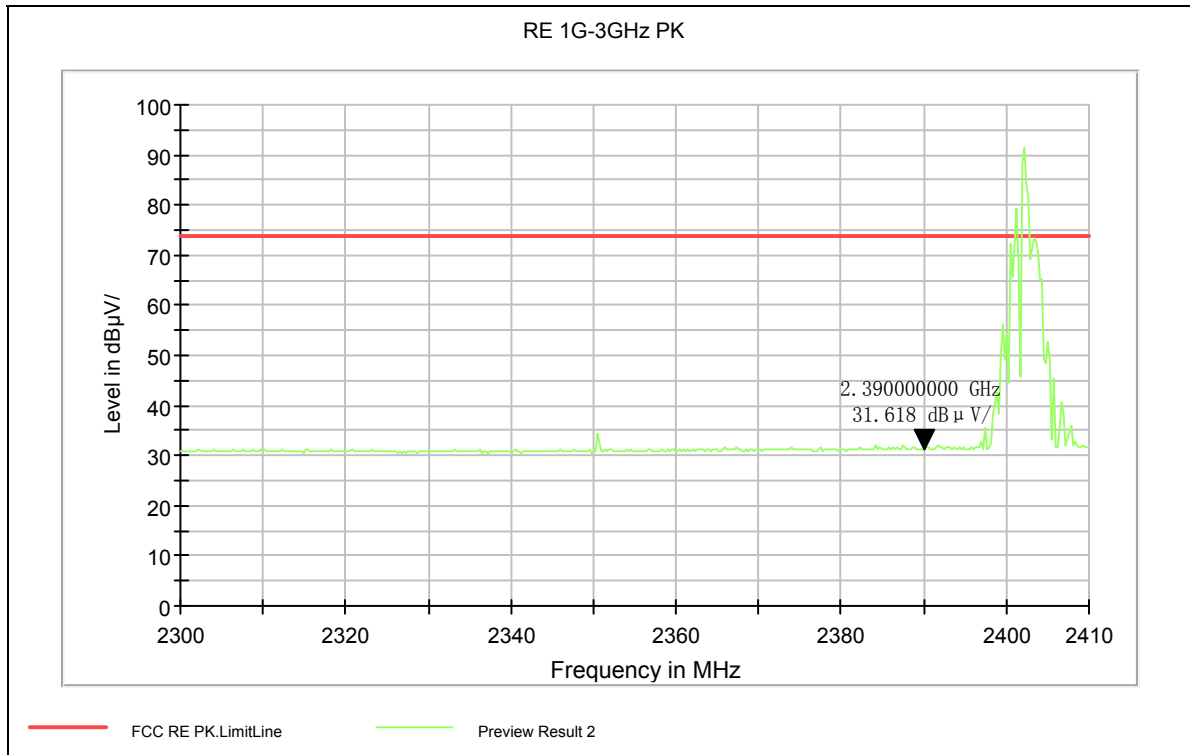

Note: The signal beyond the limit is carrier

The Peak value is under the Average value Limit, so the Average detector is not required.

Basic Rate- Channel 78

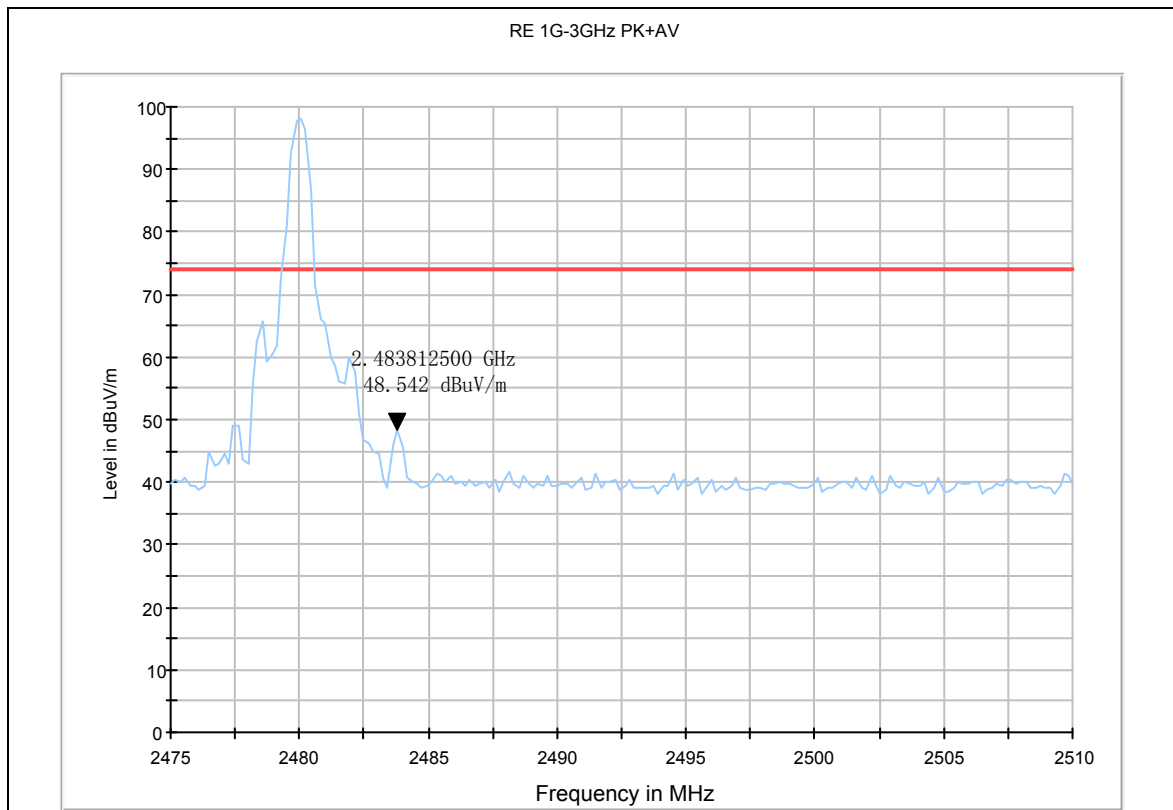

Note: The signal beyond the limit is carrier

The Peak value is under the Average value Limit, so the Average detector is not required.

EDR- Channel 0

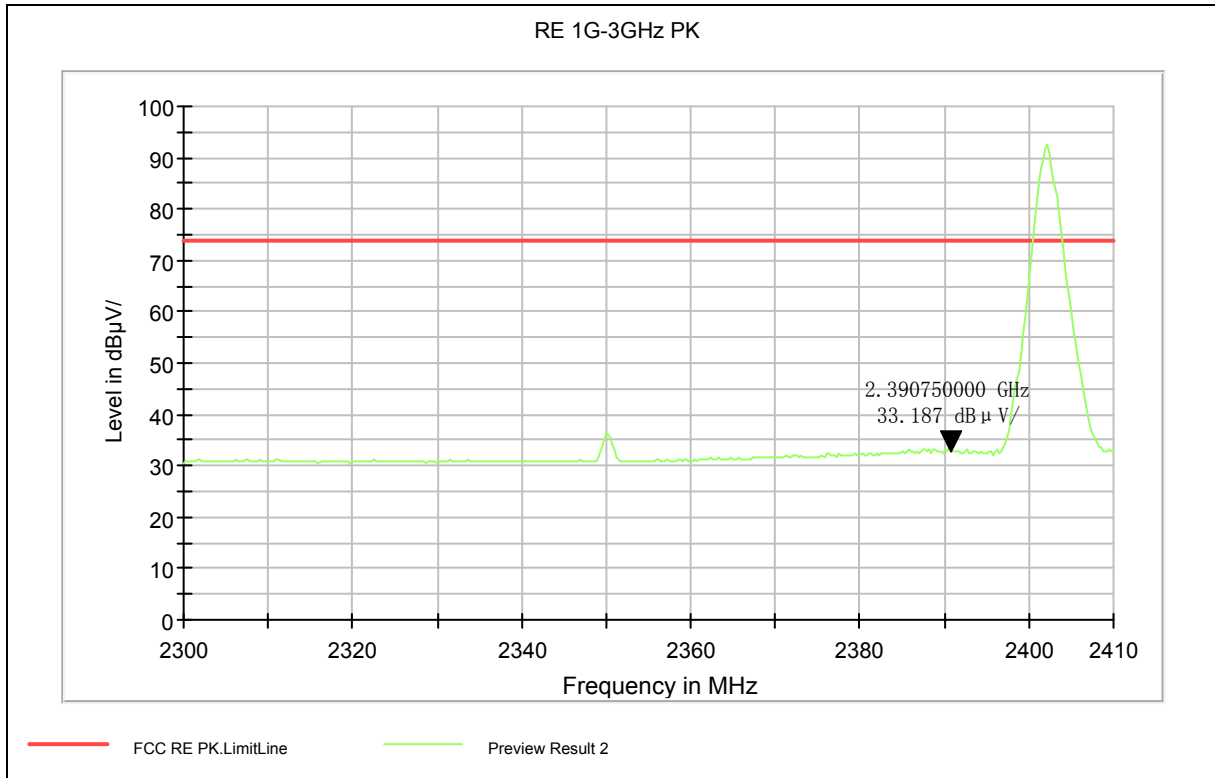

Note: The signal beyond the limit is carrier

The Peak value is under the Average value Limit,so the Average detector is not required.

EDR- Channel 78

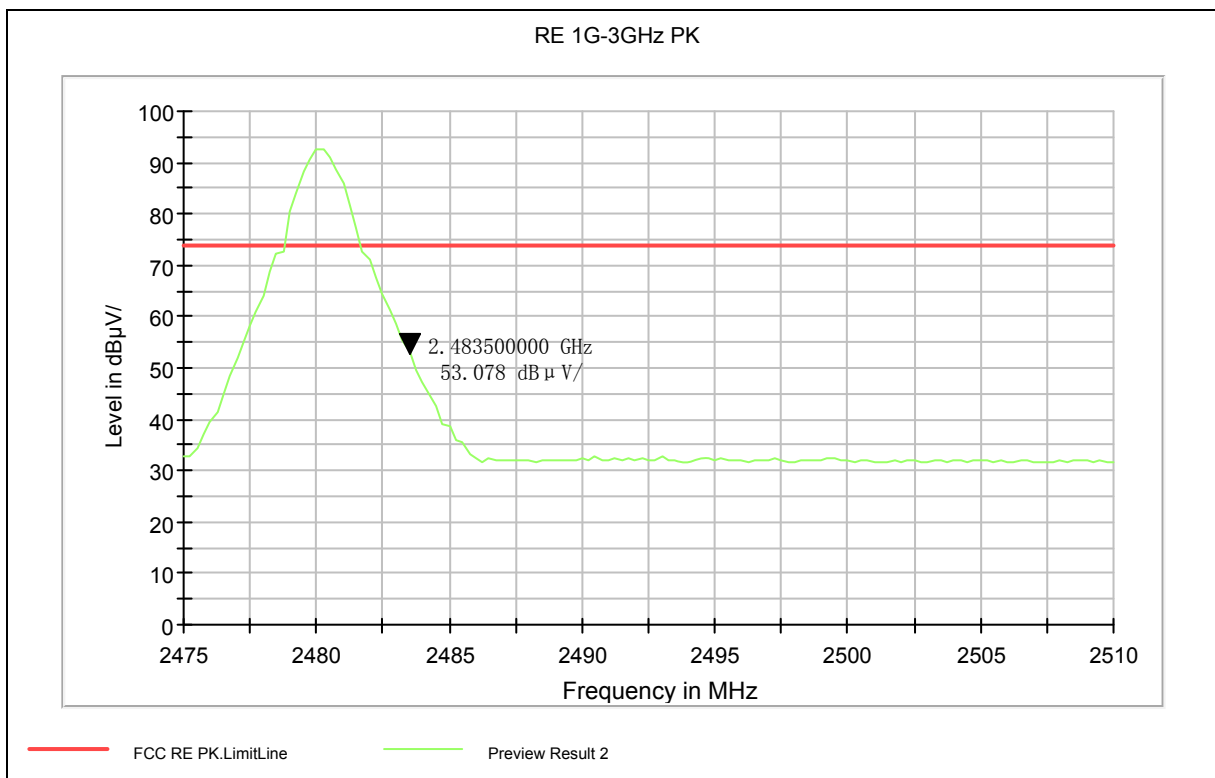

Note: The signal beyond the limit is carrier

The Peak value is under the Average value Limit,so the Average detector is not required.

**TA Technology (Shanghai) Co., Ltd.**  
**Test Report**

Registration Num:428261

Report No.: RZC1101-0124RF02

Page 38 of 91

## 2.8. Number of hopping Frequency

### Ambient condition

|             |                   |          |
|-------------|-------------------|----------|
| Temperature | Relative humidity | Pressure |
| 23°C ~25°C  | 45%~50%           | 101.5kPa |

### Method of Measurement

The Equipment Under Test (EUT) was set up in a shielded room to perform the spurious emissions measurements. The EUT was connected to the spectrum analyzer and Bluetooth test set via a power splitter with a known loss. RBW is set to 300kHz and VBW is set to 3MHz on spectrum analyzer. Set EUT on Hopping on mode.

### Test setup

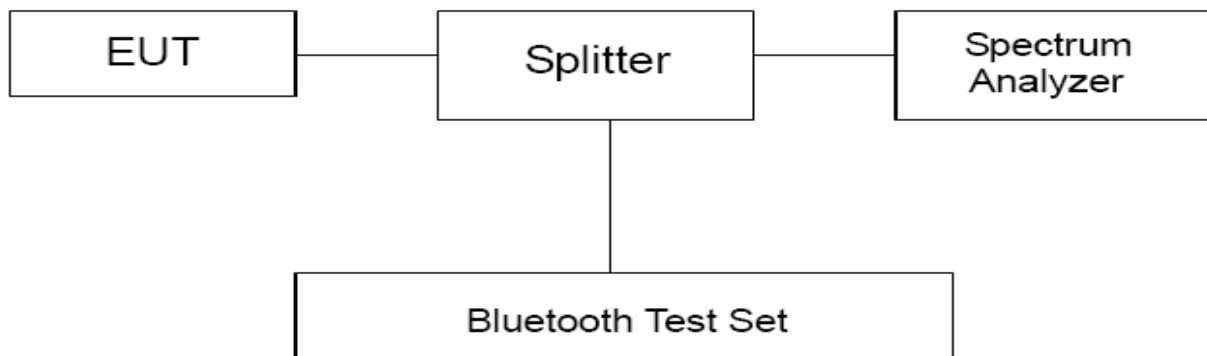

### Limits

Rule Part 15.247(a) (1) (iii) specifies that "Frequency hopping systems in the 2400–2483.5 MHz band shall use at least 15 channels..".

|        |                    |
|--------|--------------------|
| Limits | $\geq 75$ channels |
|--------|--------------------|

**TA Technology (Shanghai) Co., Ltd.**  
**Test Report**

Registration Num:428261

Report No.: RZC1101-0124RF02

Page 39 of 91

**Test Results:**

**DH5**

| Number of hopping channels | conclusion |
|----------------------------|------------|
| 79                         | PASS       |

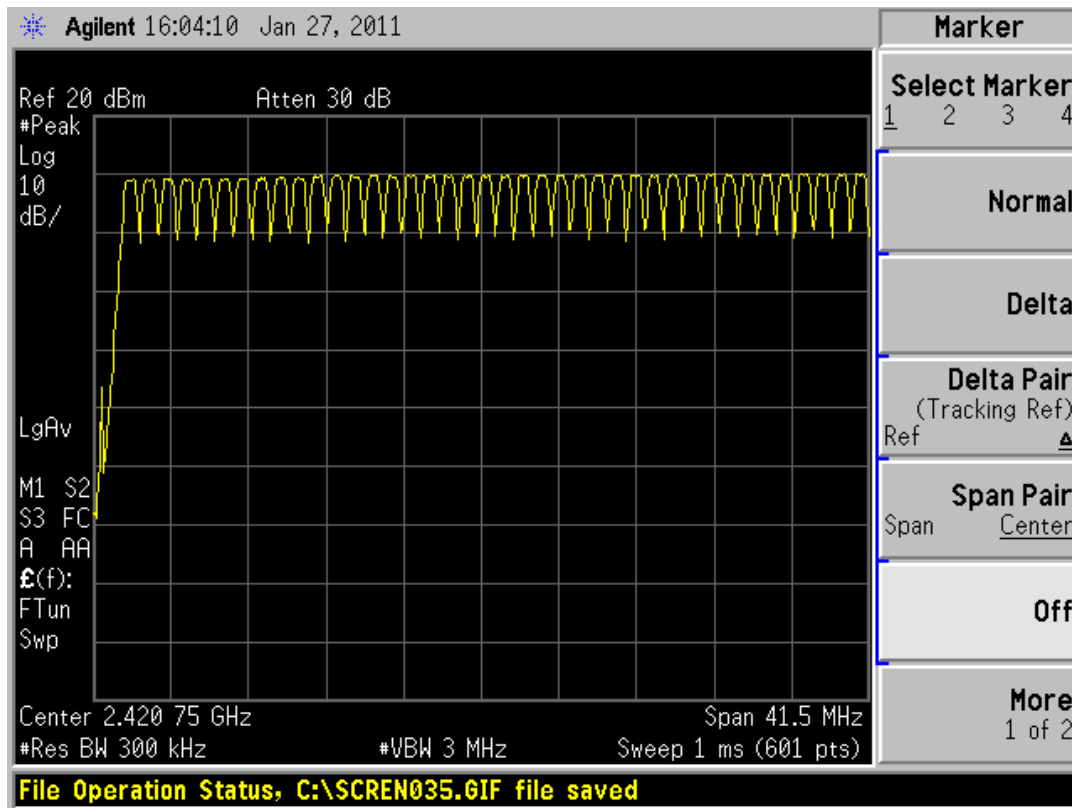

2400 MHz – 2441 MHz

TA Technology (Shanghai) Co., Ltd.  
Test Report

Registration Num:428261

Report No.: RZC1101-0124RF02

Page 40 of 91

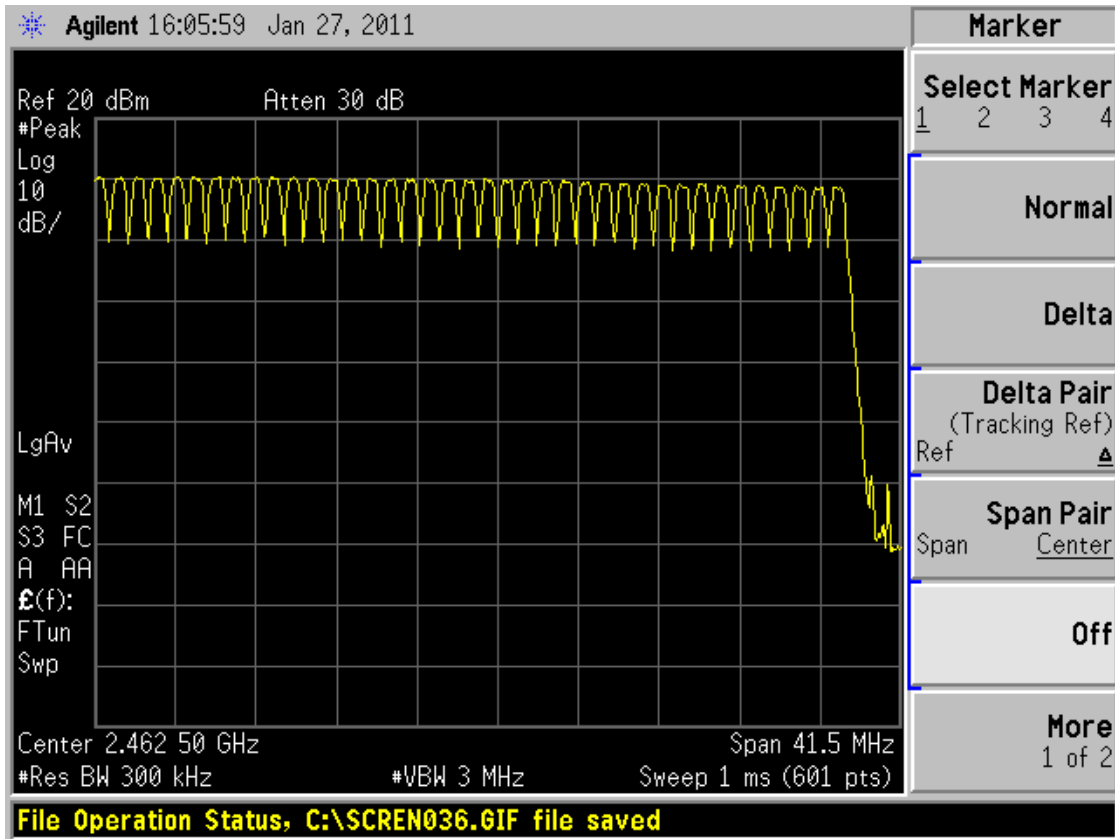

2441 MHz – 2483.5 MHz

# TA Technology (Shanghai) Co., Ltd.

## Test Report

Registration Num:428261

Report No.: RZC1101-0124RF02

Page 41 of 91

3DH5

| Number of hopping channels | conclusion |
|----------------------------|------------|
| 79                         | PASS       |

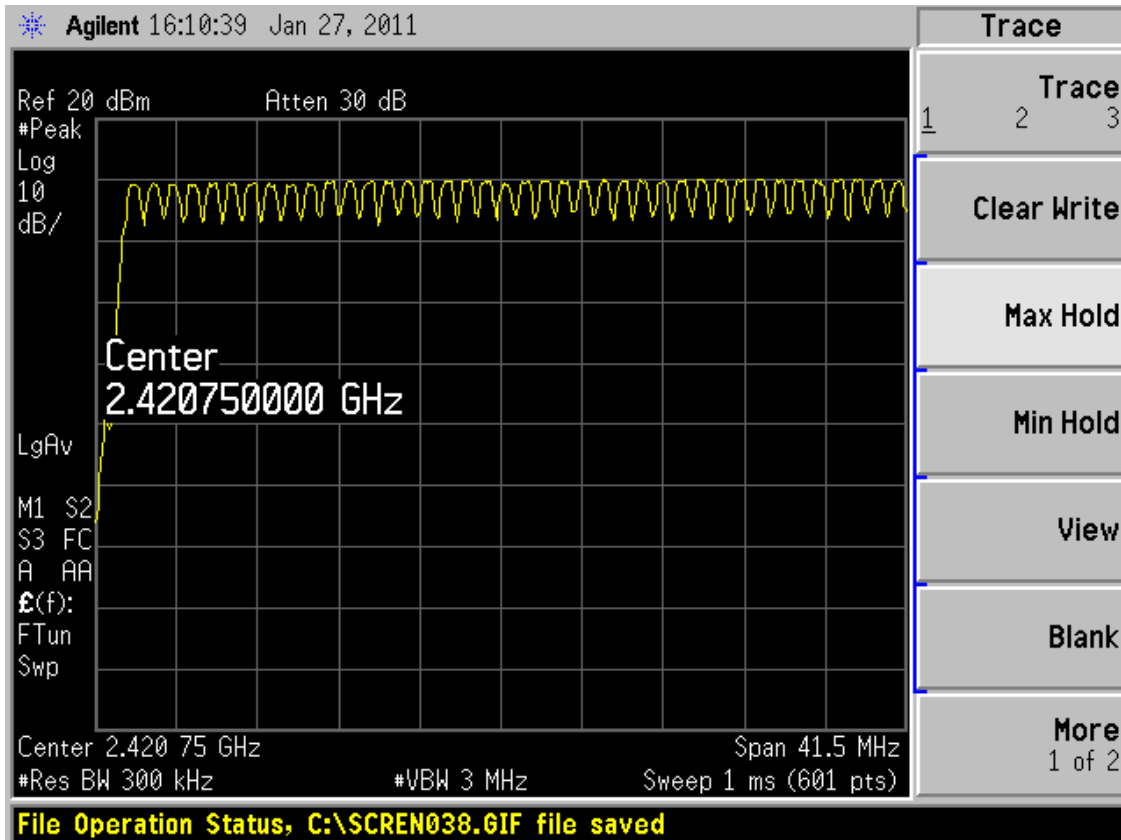

2400 MHz – 2441 MHz

TA Technology (Shanghai) Co., Ltd.  
Test Report

Registration Num:428261

Report No.: RZC1101-0124RF02

Page 42 of 91

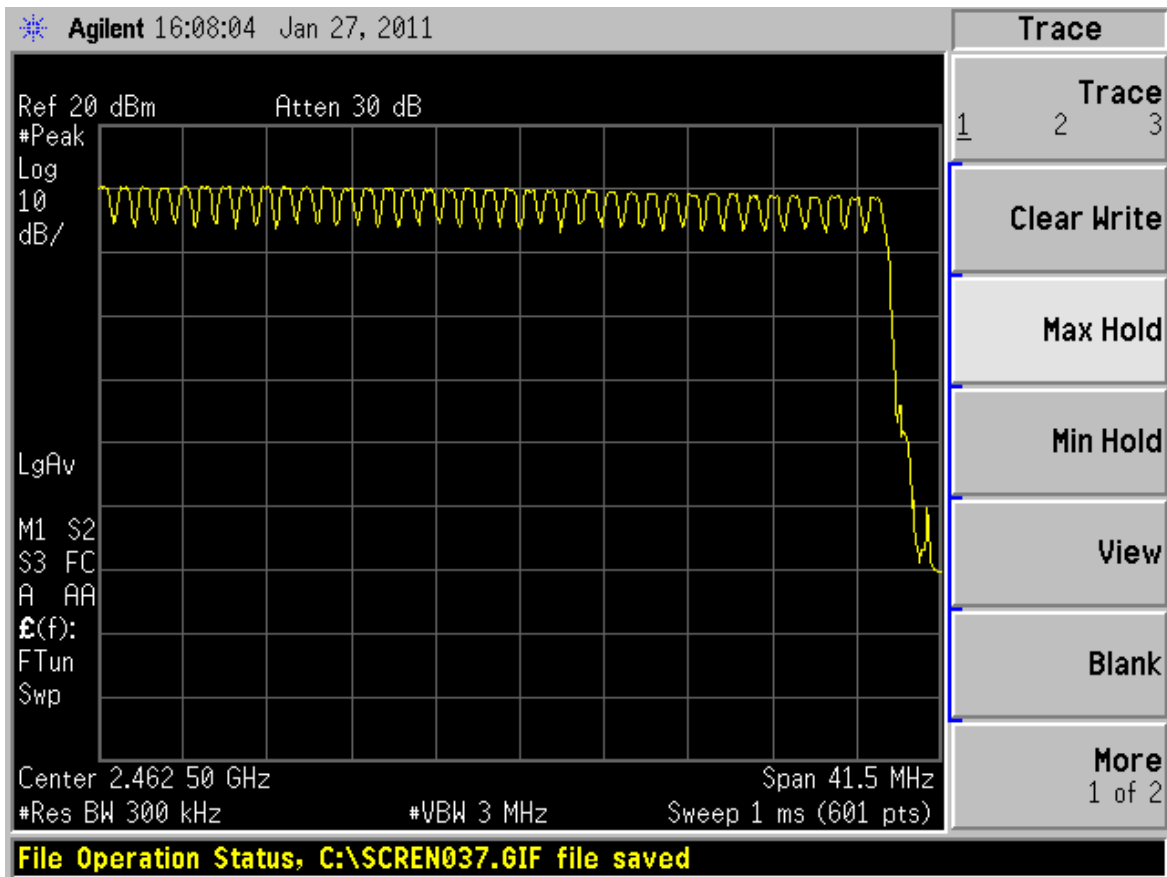

2441 MHz – 2483.5 MHz

## 2.9. Spurious RF Conducted Emissions

### Ambient condition

|             |                   |          |
|-------------|-------------------|----------|
| Temperature | Relative humidity | Pressure |
| 23°C ~25°C  | 45%~50%           | 101.5kPa |

### Method of Measurement

The EUT was connected to the spectrum analyzer and Bluetooth test set via a power splitter with a known loss. The spectrum analyzer scans from 30MHz to 26GHz. The peak detector is used. RBW and VBW are set to 100 kHz, Sweep is set to ATUO.

The test is in transmit mode.

### Test setup

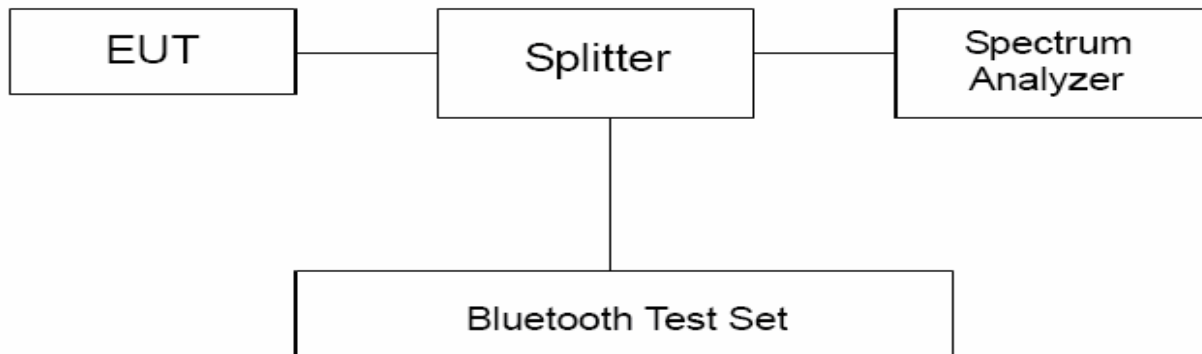

### Limits

Rule Part 15.247(d) pacifies that “In any 100 kHz bandwidth outside the frequency band in which the spread spectrum intentional radiator is operating, the radio frequency power that is produced by the intentional radiator shall be at least 20 dB below that in the 100 kHz bandwidth within the band that contains the highest level of the desired power.”

| Mode       | Carrier frequency (MHz) | Reference value (dBm) | Limit   |
|------------|-------------------------|-----------------------|---------|
| Basic Rate | 2402                    | 9.22                  | ≤-10.78 |
|            | 2441                    | 10.08                 | ≤-9.92  |
|            | 2480                    | 8.89                  | ≤-11.11 |
| EDR        | 2402                    | 7.71                  | ≤-12.29 |
|            | 2441                    | 8.62                  | ≤-11.38 |
|            | 2480                    | 7.52                  | ≤-12.48 |

**TA Technology (Shanghai) Co., Ltd.**  
**Test Report**

Registration Num:428261

Report No.: RZC1101-0124RF02

Page 44 of 91

---

**Measurement Uncertainty**

The assessed measurement uncertainty to ensure 95% confidence level for the normal distribution is with the coverage factor  $k = 1.96$ .

| Frequency   | Uncertainty |
|-------------|-------------|
| 100kHz-2GHz | 0.684 dB    |
| 2GHz-26GHz  | 1.407 dB    |

Test Results:

Basic Rate-CH0:

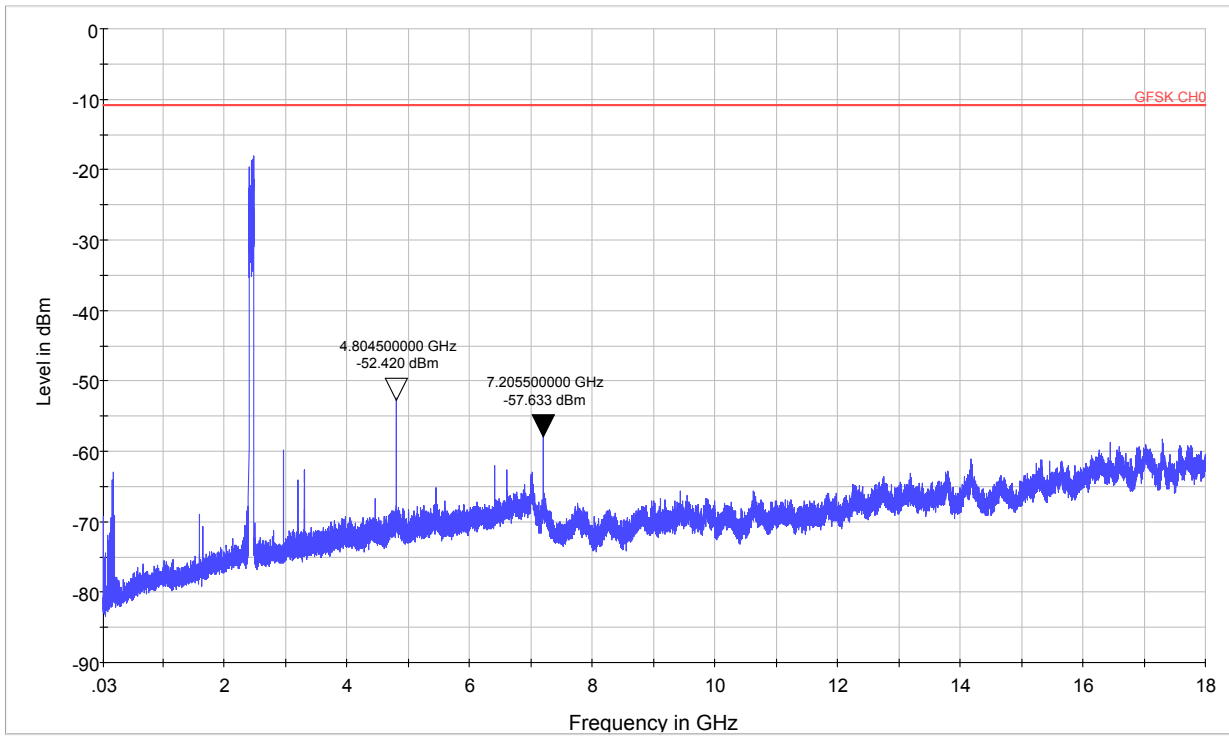

Note: The signal beyond the limit is carrier. Carrier frequency (MHz): 2402  
Spurious RF conducted emissions from 30MHz to 18GHz

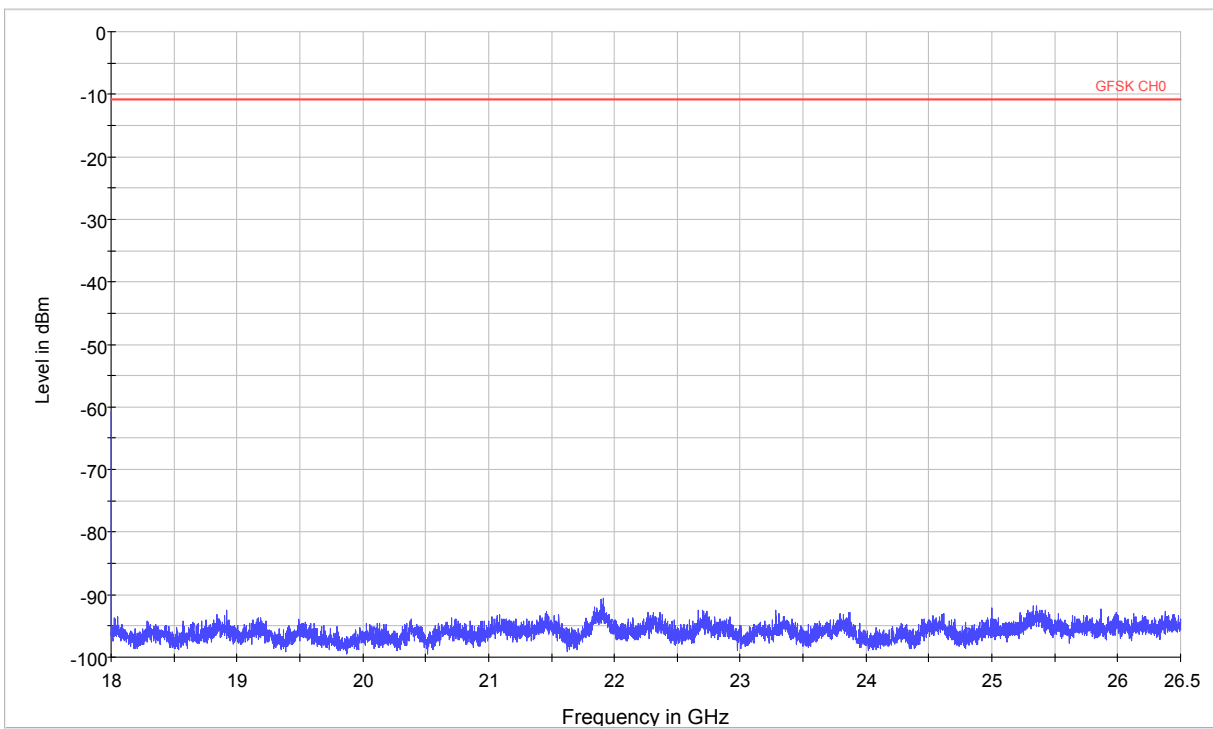

Spurious RF conducted emissions from 18GHz to 26.5GHz

**TA Technology (Shanghai) Co., Ltd.**  
**Test Report**

Registration Num:428261

Report No.: RZC1101-0124RF02

Page 46 of 91

| Harmonic        | TX ch.0<br>Frequency (MHz) | Level<br>(dBm) | Limit<br>(dBm) |
|-----------------|----------------------------|----------------|----------------|
| 2               | 4804.5                     | -52.42         | -10.78         |
| 3               | 7205.5                     | -57.633        | -10.78         |
| 4               | 9608                       | Nf             | -10.78         |
| 5               | 12010                      | Nf             | -10.78         |
| 6               | 14412                      | Nf             | -10.78         |
| 7               | 16814                      | Nf             | -10.78         |
| 8               | 19216                      | Nf             | -10.78         |
| 9               | 21618                      | Nf             | -10.78         |
| 10              | 24020                      | Nf             | -10.78         |
| Nf: noise floor |                            |                |                |

Note: The other Spurious RF conducted emissions level is no more than noise floor.

Basic Rate-CH39:

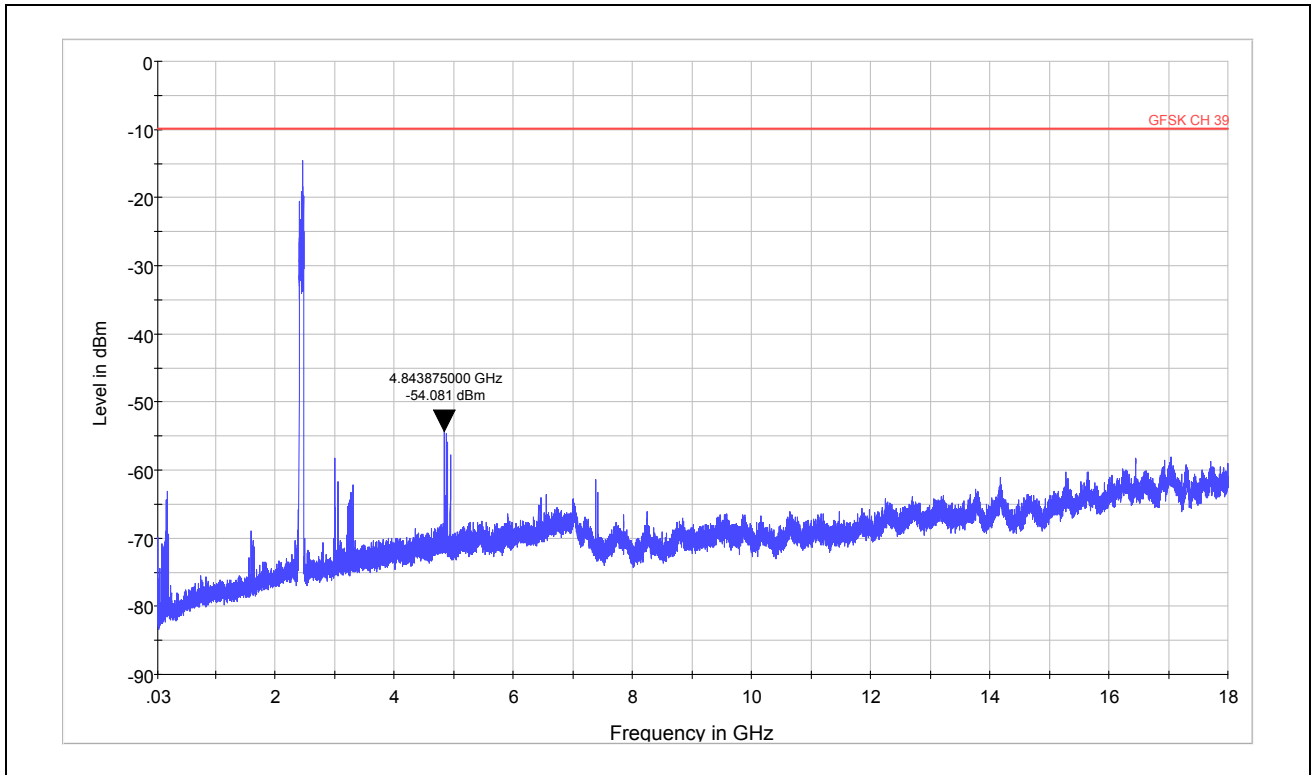

Note: The signal beyond the limit is carrier. Carrier frequency (MHz): 2441  
Spurious RF conducted emissions from 30MHz to 18GHz

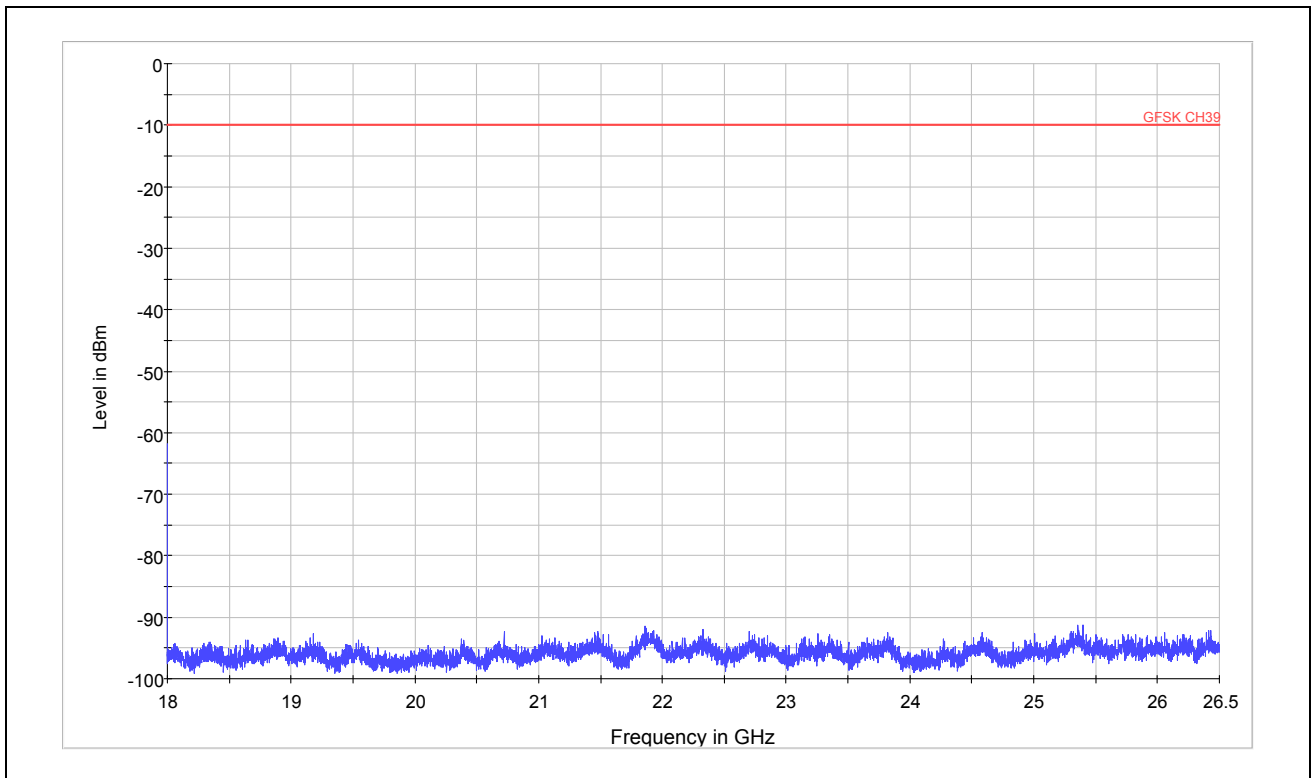

Spurious RF conducted emissions from 18GHz to 26.5GHz

**TA Technology (Shanghai) Co., Ltd.**  
**Test Report**

Registration Num:428261

Report No.: RZC1101-0124RF02

Page 48 of 91

| Harmonic        | TX ch.39<br>Frequency (MHz) | Level<br>(dBm) | Limit<br>(dBm) |
|-----------------|-----------------------------|----------------|----------------|
| 2               | 4843.875                    | -54.081        | -9.92          |
| 3               | 7323                        | Nf             | -9.92          |
| 4               | 9764                        | Nf             | -9.92          |
| 5               | 12205                       | Nf             | -9.92          |
| 6               | 14646                       | Nf             | -9.92          |
| 7               | 17087                       | Nf             | -9.92          |
| 8               | 19528                       | Nf             | -9.92          |
| 9               | 21969                       | Nf             | -9.92          |
| 10              | 24410                       | Nf             | -9.92          |
| Nf: noise floor |                             |                |                |

Note: The other Spurious RF conducted emissions level is no more than noise floor.

Basic Rate-CH78:

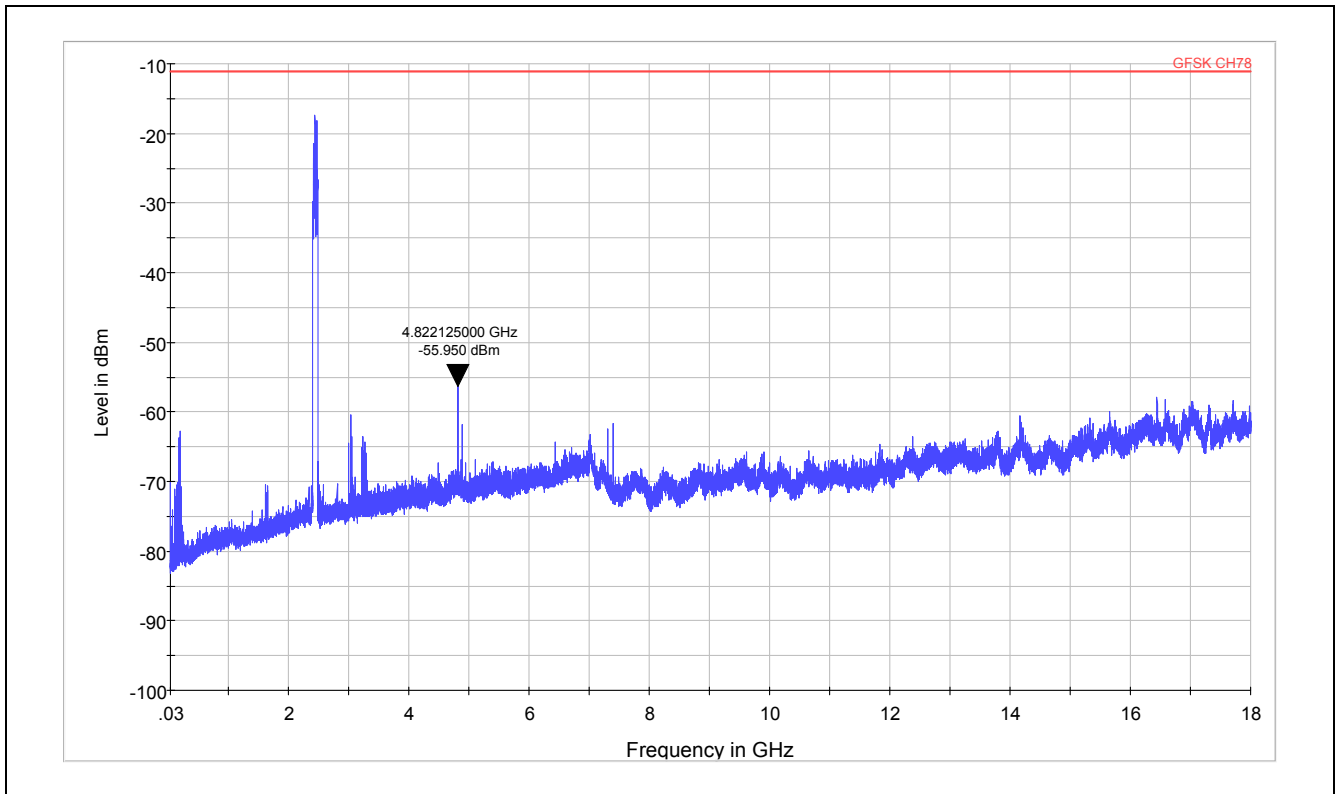

Note: The signal beyond the limit is carrier. Carrier frequency (MHz): 2480  
Spurious RF conducted emissions from 30MHz to 18GHz

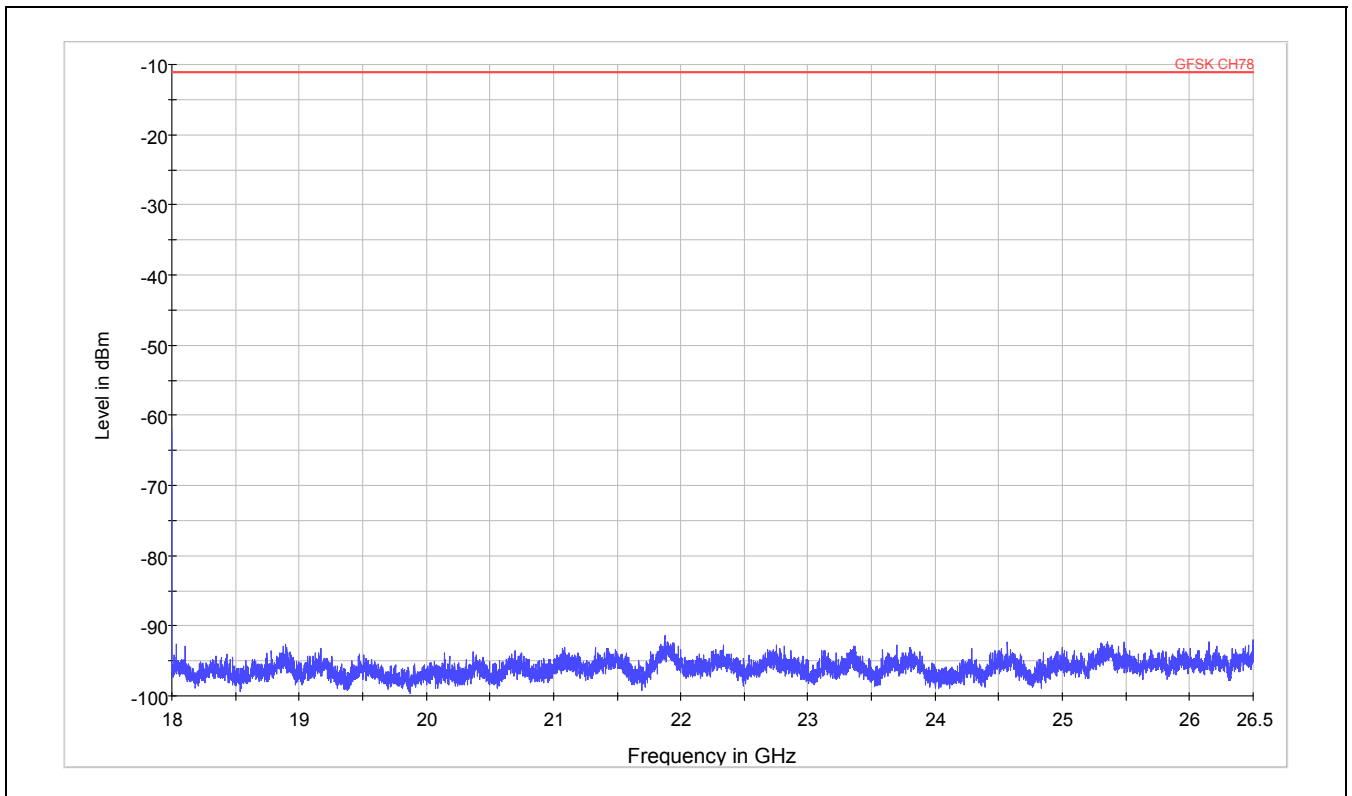

Spurious RF conducted emissions from 18GHz to 26.5GHz

**TA Technology (Shanghai) Co., Ltd.**  
**Test Report**

Registration Num:428261

Report No.: RZC1101-0124RF02

Page 50 of 91

| Harmonic        | TX ch.78<br>Frequency (MHz) | Level<br>(dBm) | Limit<br>(dBm) |
|-----------------|-----------------------------|----------------|----------------|
| 2               | 4822.125                    | -55.950        | -11.11         |
| 3               | 7440                        | Nf             | -11.11         |
| 4               | 9920                        | Nf             | -11.11         |
| 5               | 12400                       | Nf             | -11.11         |
| 6               | 14880                       | Nf             | -11.11         |
| 7               | 17360                       | Nf             | -11.11         |
| 8               | 19840                       | Nf             | -11.11         |
| 9               | 22320                       | Nf             | -11.11         |
| 10              | 24800                       | Nf             | -11.11         |
| Nf: noise floor |                             |                |                |

Note: The other Spurious RF conducted emissions level is no more than noise floor.

EDR-CH0:

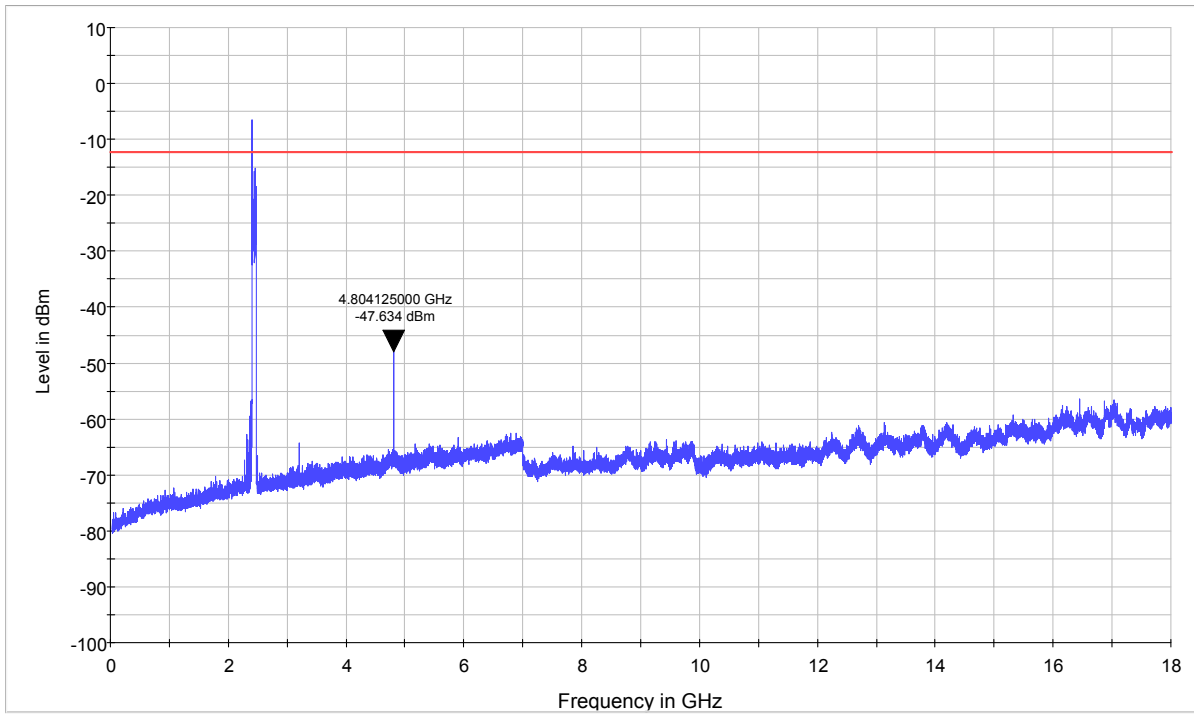

Note: The signal beyond the limit is carrier. Carrier frequency (MHz): 2402  
Spurious RF conducted emissions from 30MHz to 18GHz

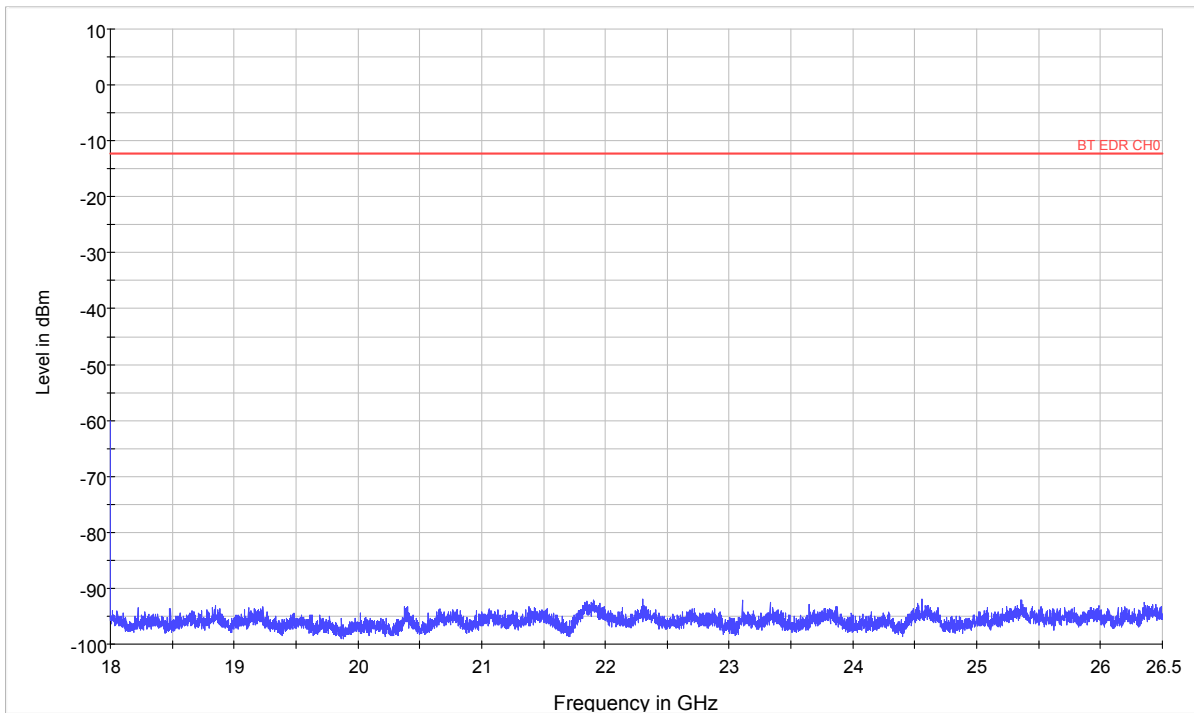

Spurious RF conducted emissions from 18GHz to 26.5GHz

**TA Technology (Shanghai) Co., Ltd.**  
**Test Report**

Registration Num:428261

Report No.: RZC1101-0124RF02

Page 52 of 91

| Harmonic        | TX ch.0<br>Frequency (MHz) | Level<br>(dBm) | Limit<br>(dBm) |
|-----------------|----------------------------|----------------|----------------|
| 2               | 4804.125                   | -47.634        | -12.29         |
| 3               | 7206                       | Nf             | -12.29         |
| 4               | 9608                       | Nf             | -12.29         |
| 5               | 12010                      | Nf             | -12.29         |
| 6               | 14412                      | Nf             | -12.29         |
| 7               | 16814                      | Nf             | -12.29         |
| 8               | 19216                      | Nf             | -12.29         |
| 9               | 21618                      | Nf             | -12.29         |
| 10              | 24020                      | Nf             | -12.29         |
| Nf: noise floor |                            |                |                |

Note: The other Spurious RF conducted emissions level is no more than noise floor.

EDR-CH39:

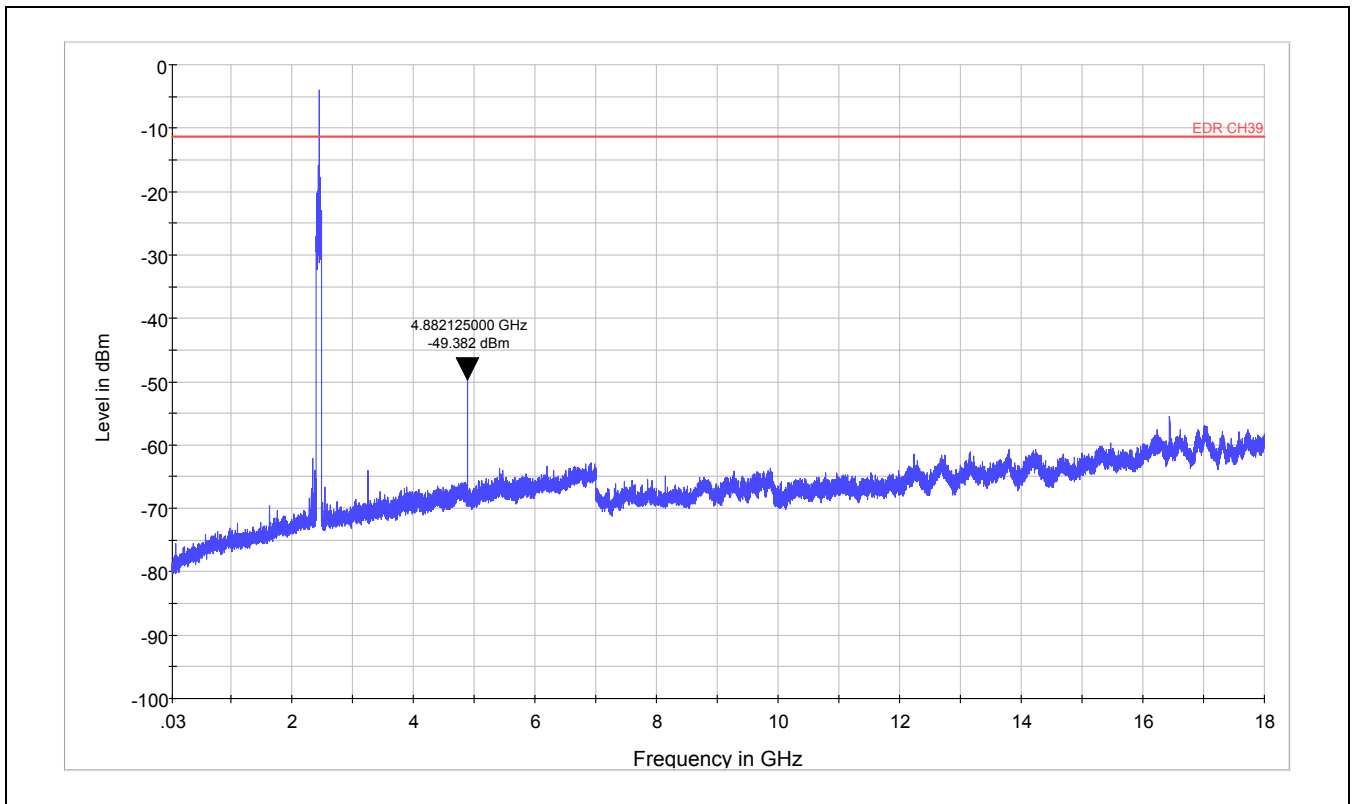

Note: The signal beyond the limit is carrier. Carrier frequency (MHz): 2441  
Spurious RF conducted emissions from 30MHz to 18GHz

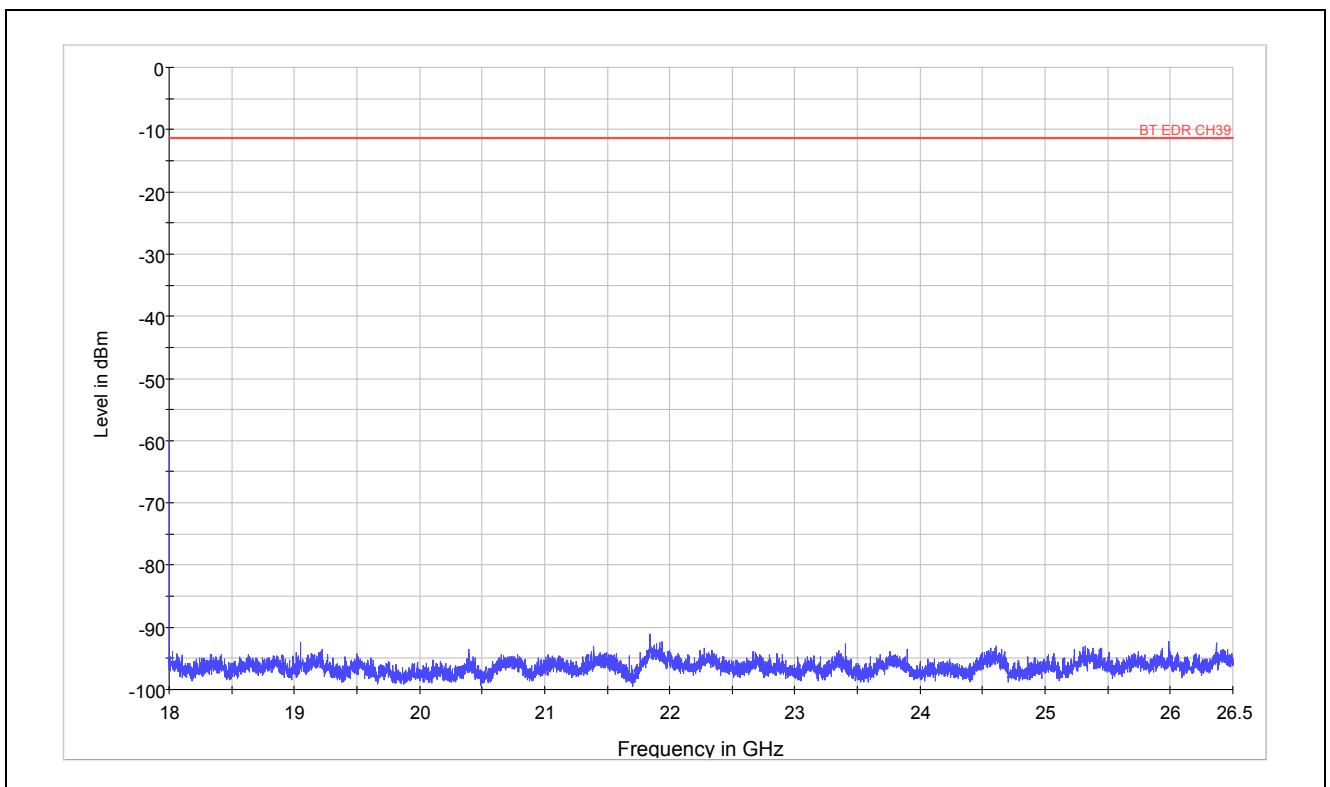

Spurious RF conducted emissions from 18GHz to 26.5GHz

**TA Technology (Shanghai) Co., Ltd.**  
**Test Report**

Registration Num:428261

Report No.: RZC1101-0124RF02

Page 54 of 91

| Harmonic        | TX ch.39<br>Frequency (MHz) | Level<br>(dBm) | Limit<br>(dBm) |
|-----------------|-----------------------------|----------------|----------------|
| 2               | 4882.125                    | -49.382        | -11.38         |
| 3               | 7323                        | Nf             | -11.38         |
| 4               | 9764                        | Nf             | -11.38         |
| 5               | 12205                       | Nf             | -11.38         |
| 6               | 14646                       | Nf             | -11.38         |
| 7               | 17087                       | Nf             | -11.38         |
| 8               | 19528                       | Nf             | -11.38         |
| 9               | 21969                       | Nf             | -11.38         |
| 10              | 24410                       | Nf             | -11.38         |
| Nf: noise floor |                             |                |                |

Note: The other Spurious RF conducted emissions level is no more than noise floor.

EDR-CH78:

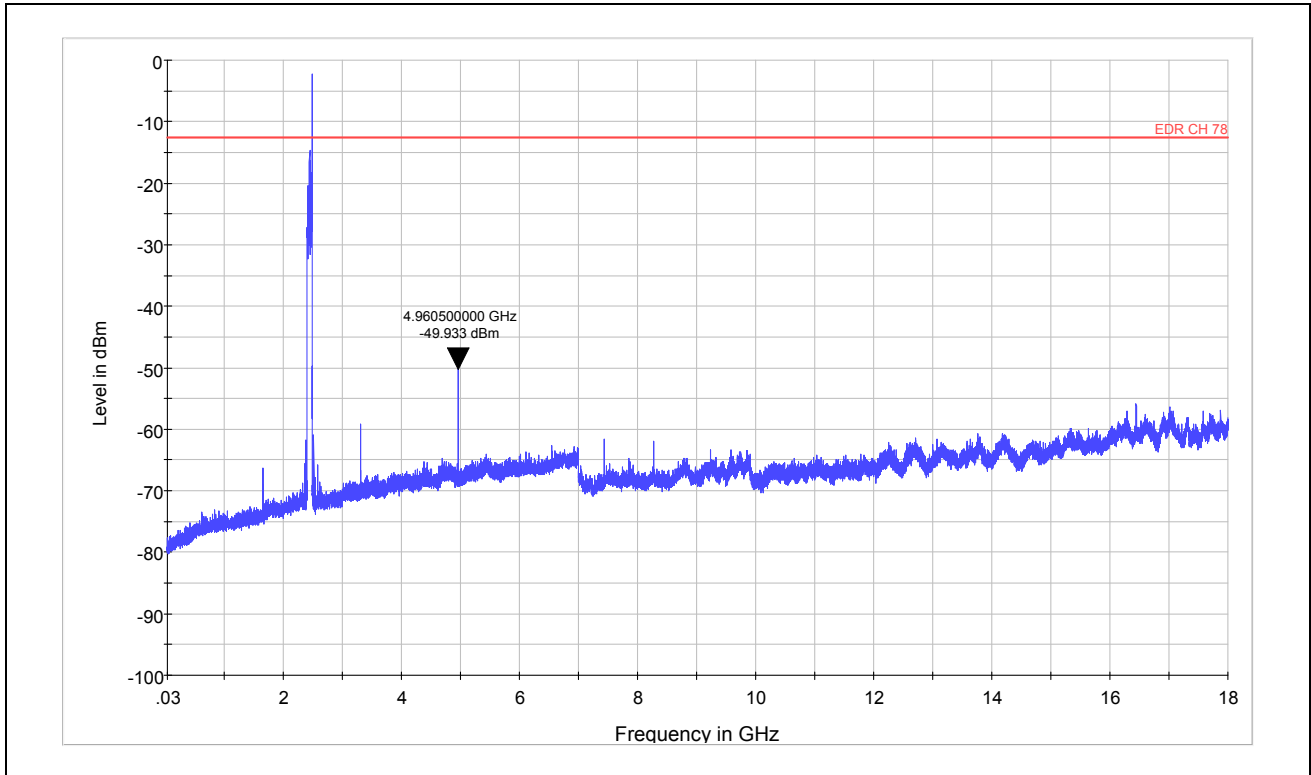

Note: The signal beyond the limit is carrier. Carrier frequency (MHz): 2480  
Spurious RF conducted emissions from 30MHz to 18GHz

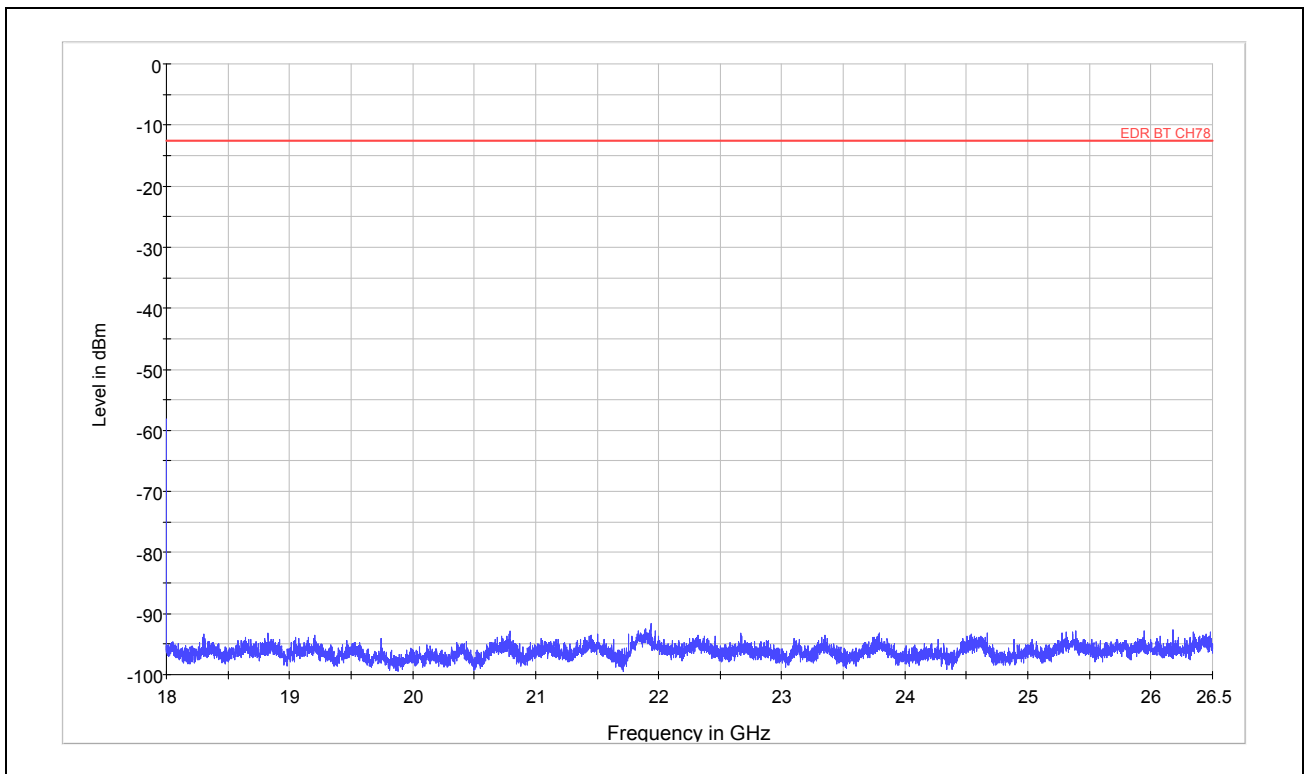

Spurious RF conducted emissions from 18GHz to 26.5GHz

**TA Technology (Shanghai) Co., Ltd.**  
**Test Report**

Registration Num:428261

Report No.: RZC1101-0124RF02

Page 56 of 91

| Harmonic        | TX ch.78<br>Frequency (MHz) | Level<br>(dBm) | Limit<br>(dBm) |
|-----------------|-----------------------------|----------------|----------------|
| 2               | 4960.5                      | -49.933        | -12.48         |
| 3               | 7440                        | Nf             | -12.48         |
| 4               | 9920                        | Nf             | -12.48         |
| 5               | 12400                       | Nf             | -12.48         |
| 6               | 14880                       | Nf             | -12.48         |
| 7               | 17360                       | Nf             | -12.48         |
| 8               | 19840                       | Nf             | -12.48         |
| 9               | 22320                       | Nf             | -12.48         |
| 10              | 24800                       | Nf             | -12.48         |
| Nf: noise floor |                             |                |                |

Note: The other Spurious RF conducted emissions level is no more than noise floor.

**2.10. Radiates Emission**

**Ambient condition**

|             |                   |          |
|-------------|-------------------|----------|
| Temperature | Relative humidity | Pressure |
| 23°C ~25°C  | 45%~50%           | 102.5kPa |

**Method of Measurement**

The test set-up was made in accordance to the general provisions of ANSI C63.4-2003. The Equipment Under Test (EUT) was set up on a non-conductive table in the semi-anechoic chamber. The test was performed at the distance of 3 m between the EUT and the receiving antenna. The radiated emissions measurements were made in a typical installation configuration. Sweep the whole frequency band through the range from 30MHz to 26GHz during the test, the height of receive antenna shall be moved from 1 to 4 meters, and the antenna shall be performed under horizontal and vertical polarization. The turntable shall be rotated from 0 to 360 degrees for detecting the maximum of radiated spurious signal level. The measurements shall be repeated with orthogonal polarization of the test antenna. The data of cable loss and antenna factor has been calibrated in full testing frequency range before the testing.

Set the spectrum analyzer in the following:

Below 1GHz:

RBW=100kHz / VBW=300kHz / Sweep=AUTO

Above 1GHz:

(a) PEAK: RBW=1MHz VBW=3MHz/ Sweep=AUTO

(b) AVERAGE: RBW=1MHz / VBW=10Hz / Sweep=AUTO

The test is in transmit mode.

**Test setup**

**Below 1GHz**

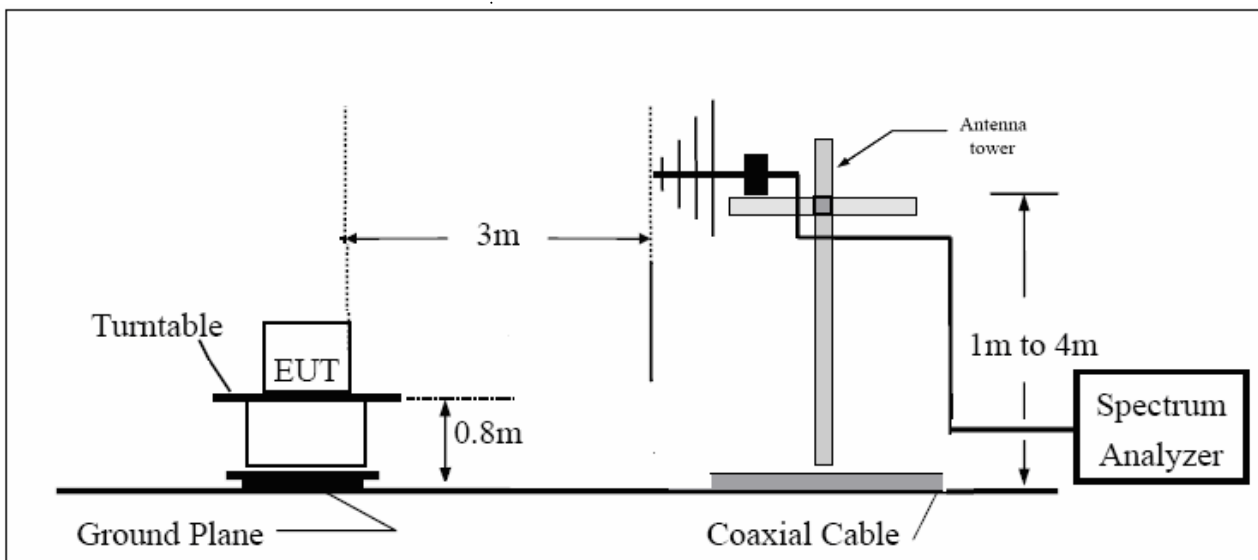

**Above 1GHz**

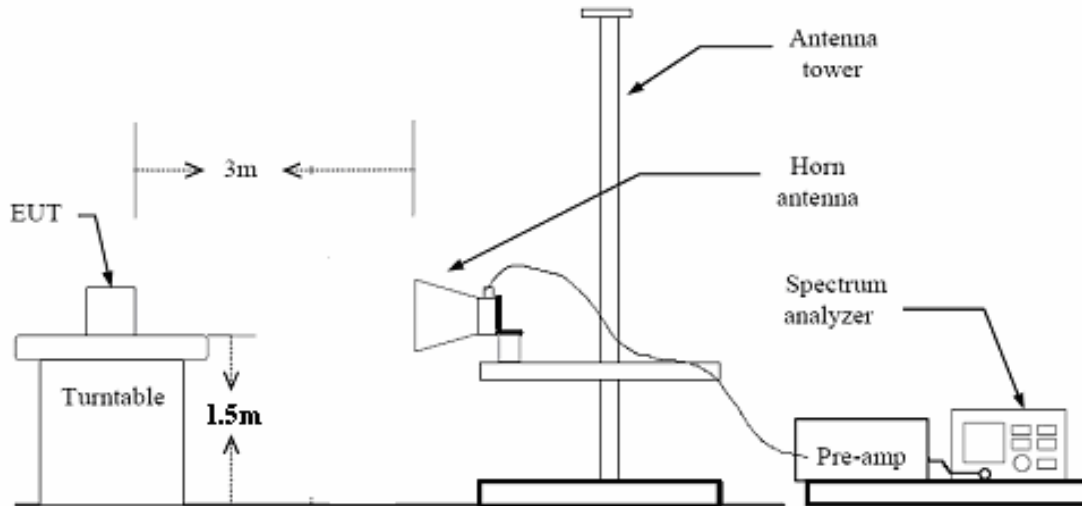

**Limits**

Rule Part 15.247(d) specifies that “In addition, radiated emissions which fall in the restricted bands, as defined in § 15.205(a), must also comply with the radiated emission limits specified in § 15.209(a) (see § 15.205(c)).”

Limit in restricted band

| Frequency of emission (MHz) | Field strength(uV/m) | Field strength(dBuV/m) |
|-----------------------------|----------------------|------------------------|
| 30-88                       | 100                  | 40                     |
| 88-216                      | 150                  | 43.5                   |
| 216-960                     | 200                  | 46                     |
| Above 960                   | 500                  | 54                     |

§15.35(b)

There is also a limit on the radio frequency emissions, as measured using instrumentation with a peak detector function, corresponding to 20 dB above the maximum permitted average limit.

**Measurement Uncertainty**

The assessed measurement uncertainty to ensure 95% confidence level for the normal distribution is with the coverage factor  $k = 1.96$ .  $U=3.92$  dB.

Test result

Basic Rate-Channel 0

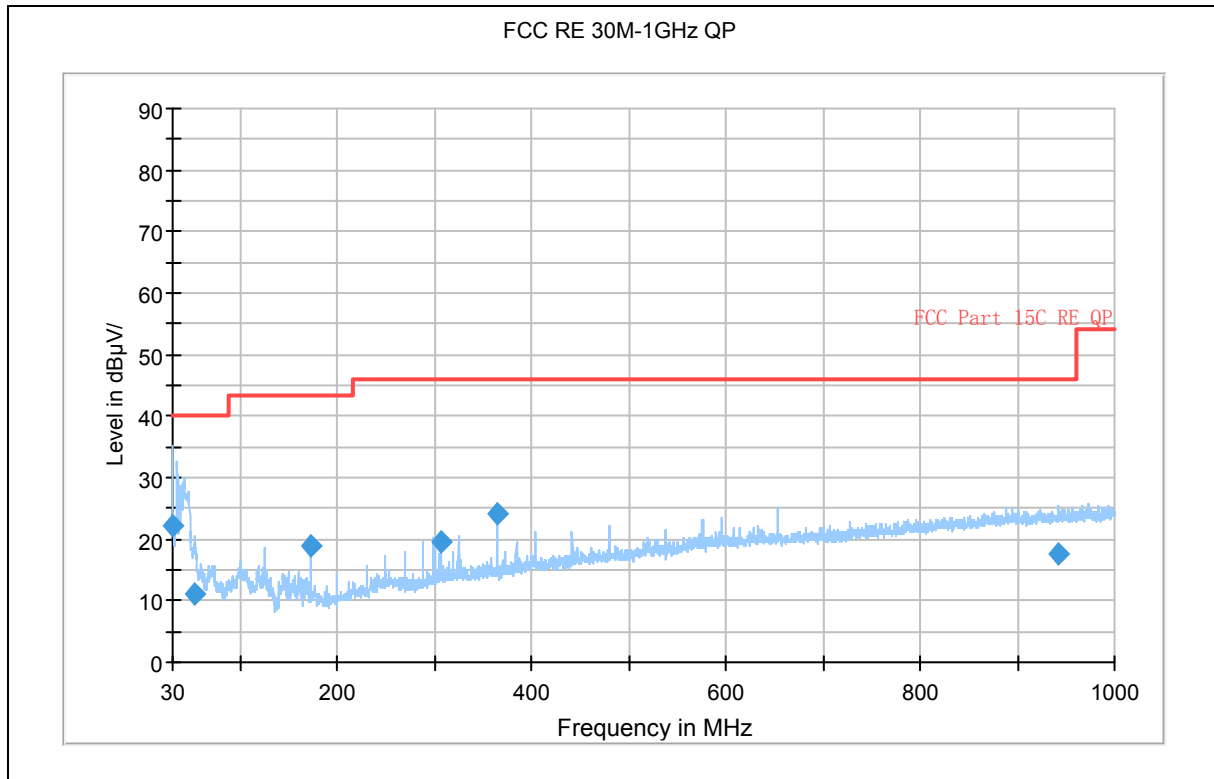

Radiates Emission from 30MHz to 1GHz

| Frequency (MHz) | Quasi-Peak (dBuV/m) | Height (cm) | Polarization | Azimuth (deg) | Reading value (dBuV/m) | Corr. Factor (dB) | Margin (dB) | Limit (dBuV/m) |
|-----------------|---------------------|-------------|--------------|---------------|------------------------|-------------------|-------------|----------------|
| 30.000000       | 22.1                | 100.0       | V            | 15.0          | 45.9                   | -23.8             | 17.9        | 40.0           |
| 53.527500       | 11.1                | 100.0       | V            | 220.0         | 37.3                   | -26.2             | 28.9        | 40.0           |
| 172.792500      | 19.0                | 100.0       | V            | 233.0         | 50.6                   | -31.6             | 24.5        | 43.5           |
| 307.177500      | 19.4                | 100.0       | H            | 49.0          | 46.2                   | -26.8             | 26.6        | 46.0           |
| 364.810000      | 24.3                | 100.0       | H            | 16.0          | 50.2                   | -25.9             | 21.7        | 46.0           |
| 941.957500      | 17.8                | 125.0       | V            | 45.0          | 34.4                   | -16.6             | 28.2        | 46.0           |

Remark: 1. Quasi-Peak = Reading value + Correction factor

2. Correction Factor = Insertion loss + Cable loss

3. Margin = Limit - Quasi-Peak

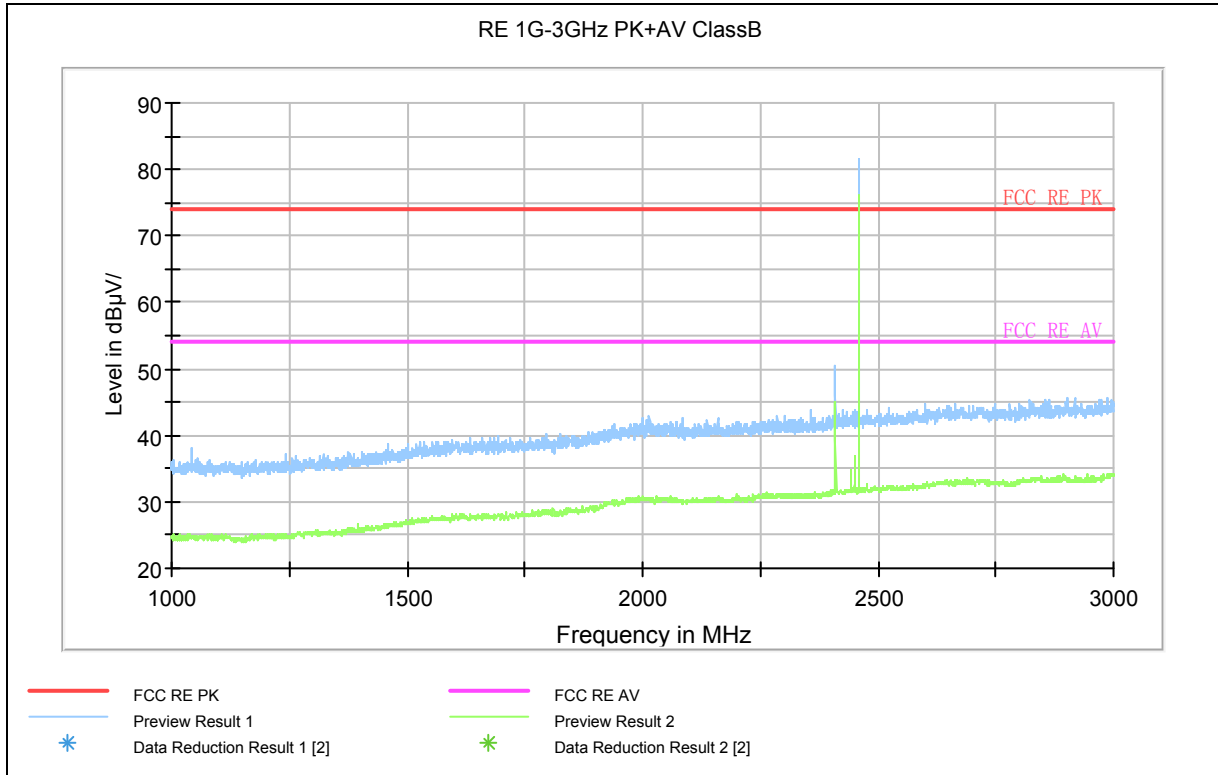

Note: The signal beyond the limit is carrier.  
Radiates Emission from 1GHz to 3GHz

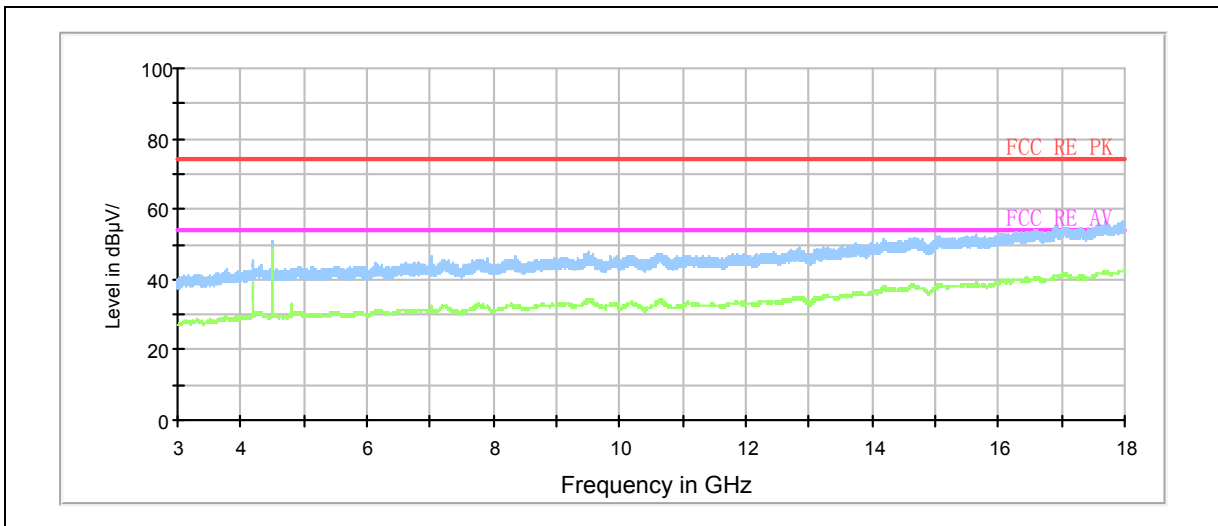

Radiates Emission from 3GHz to 18GHz

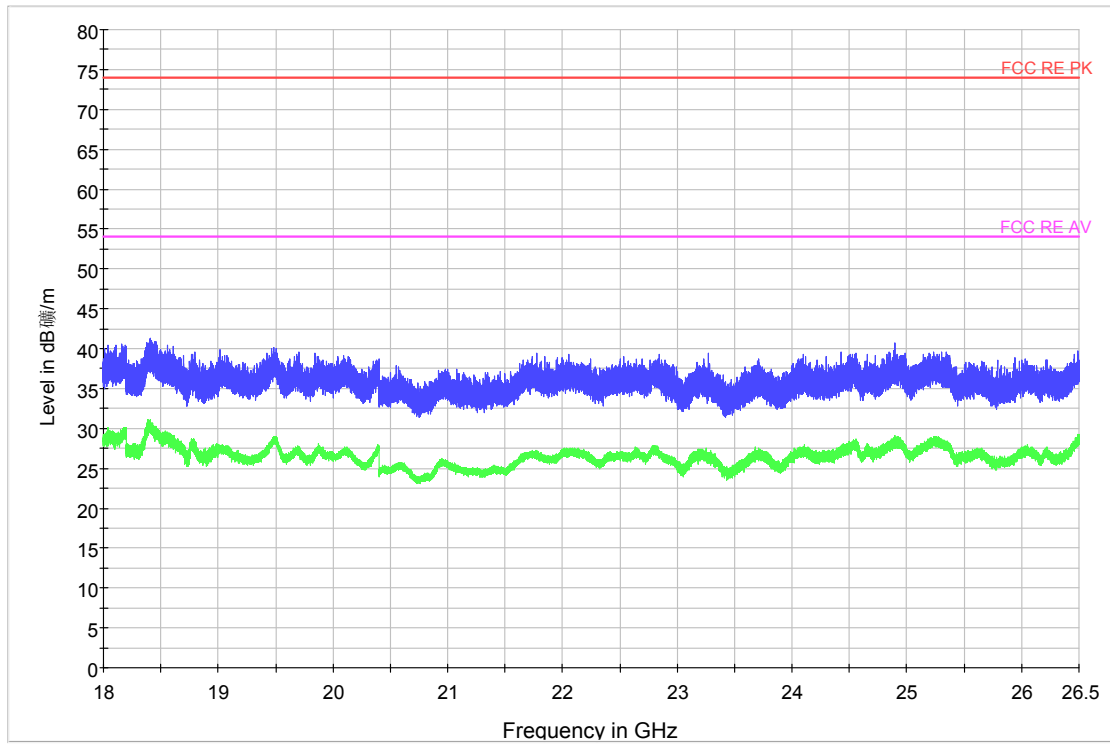

Radiates Emission from 18GHz to 26.5GHz

Basic Rate-Channel 39

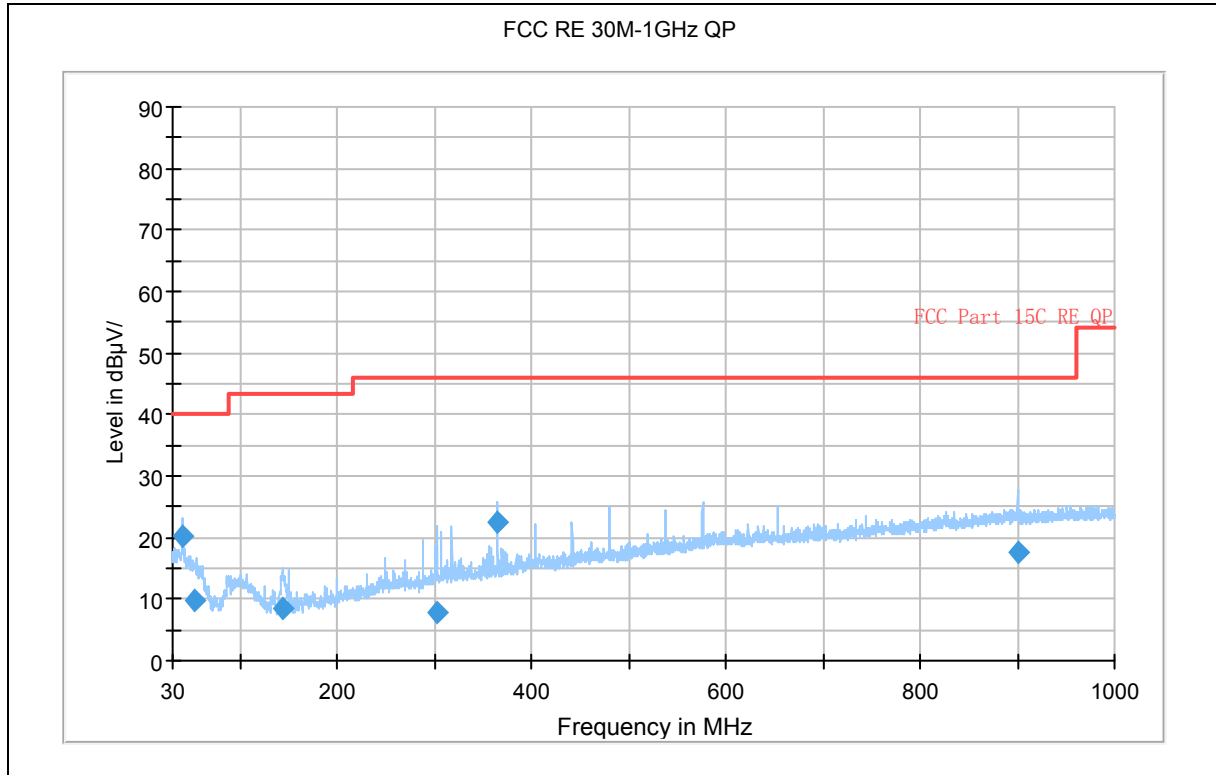

Radiates Emission from 30MHz to 1GHz

| Frequency (MHz) | Quasi-Peak (dBuV/m) | Height (cm) | Polarization | Azimuth (deg) | Reading value (dBuV/m) | Corr. Factor (dB) | Margin (dB) | Limit (dBuV/m) |
|-----------------|---------------------|-------------|--------------|---------------|------------------------|-------------------|-------------|----------------|
| 40.022500       | 20.2                | 100.0       | V            | 0.0           | 44.2                   | -24.0             | 19.8        | 40.0           |
| 53.650000       | 9.8                 | 100.0       | H            | 37.0          | 36                     | -26.2             | 30.2        | 40.0           |
| 144.010000      | 8.3                 | 100.0       | V            | 45.0          | 41.1                   | -32.8             | 35.2        | 43.5           |
| 302.892500      | 7.9                 | 100.0       | H            | 45.0          | 34.9                   | -27.0             | 38.1        | 46.0           |
| 364.810000      | 22.4                | 100.0       | H            | 16.0          | 48.3                   | -25.9             | 23.6        | 46.0           |
| 900.090000      | 17.5                | 100.0       | H            | 285.0         | 34.4                   | -16.9             | 28.6        | 46.0           |

Remark: 1. Quasi-Peak = Reading value + Correction factor

2. Correction Factor = Insertion loss + Cable loss

3. Margin = Limit - Quasi-Peak

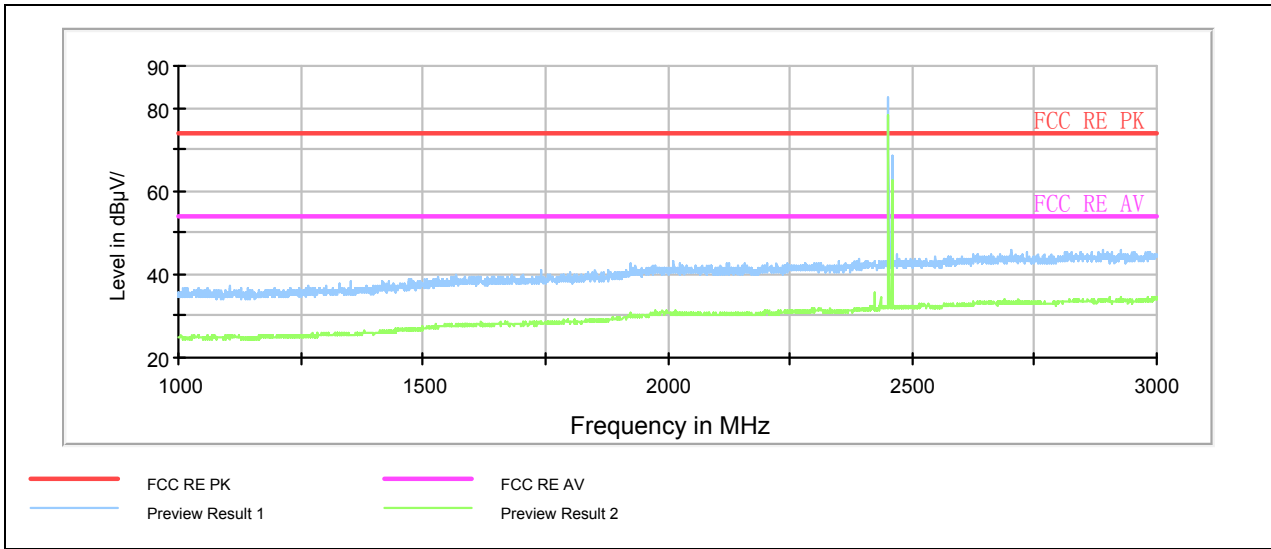

Note: The signal beyond the limit is carrier.  
Radiates Emission from 1GHz to 3GHz

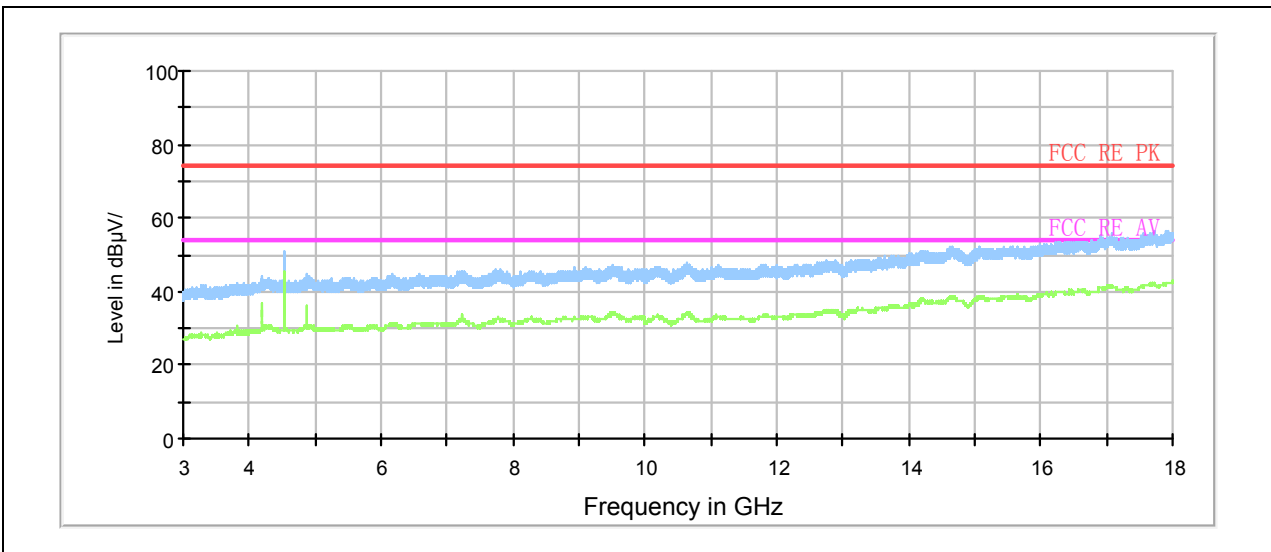

Radiates Emission from 3GHz to 18GHz

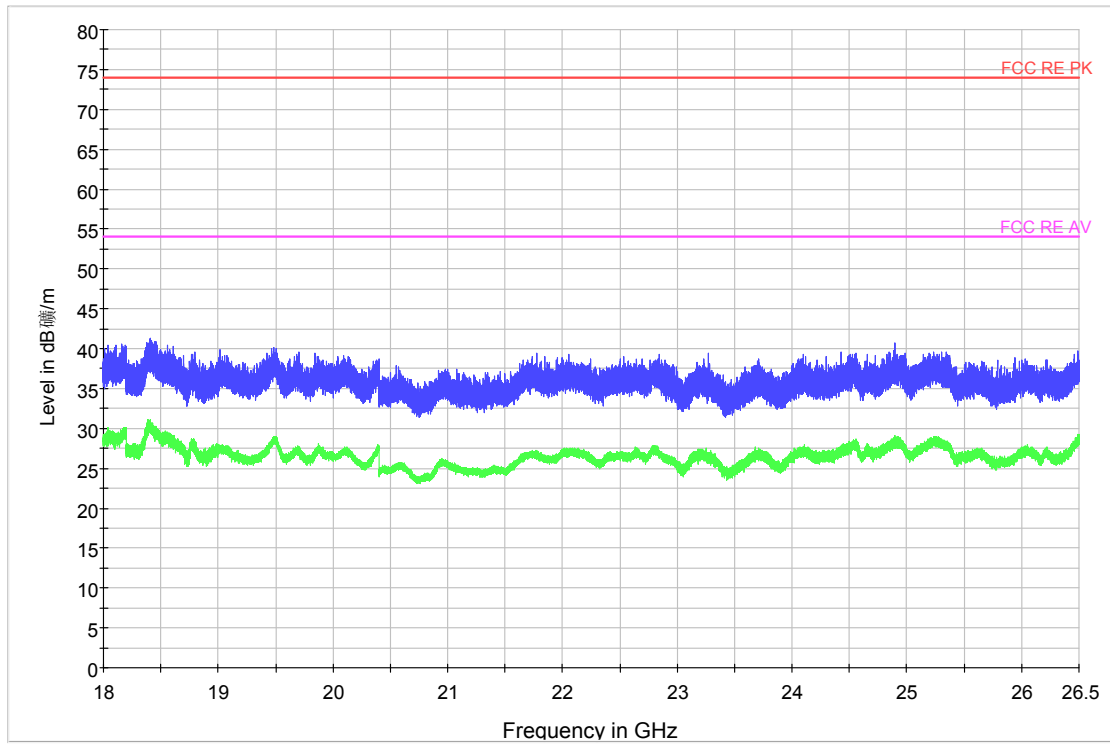

Radiates Emission from 18GHz to 26.5GHz

Basic Rate-Channel 78

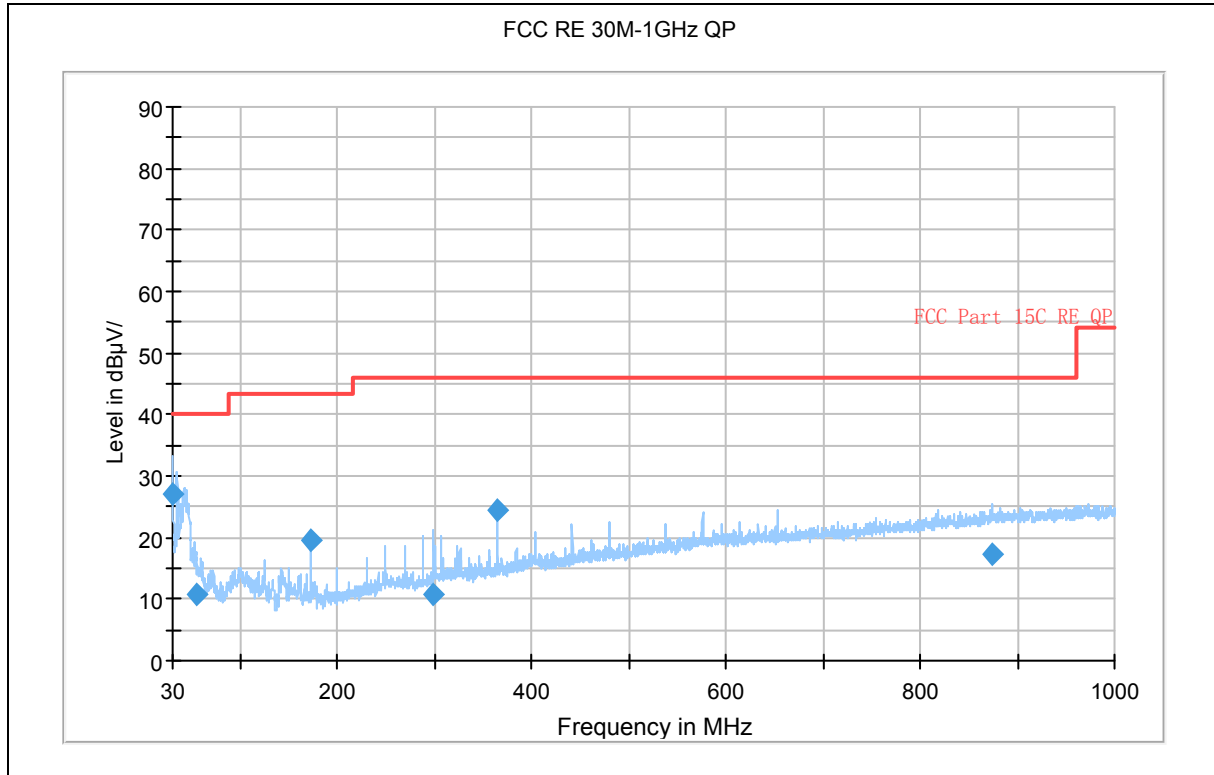

Radiates Emission from 30MHz to 1GHz

| Frequency (MHz) | Quasi-Peak (dBuV/m) | Height (cm) | Polarization | Azimuth (deg) | Reading value (dBuV/m) | Corr. Factor (dB) | Margin (dB) | Limit (dBuV/m) |
|-----------------|---------------------|-------------|--------------|---------------|------------------------|-------------------|-------------|----------------|
| 30.240000       | 26.9                | 100.0       | V            | 0.0           | 50.7                   | -23.8             | 13.1        | 40.0           |
| 54.007500       | 10.8                | 116.0       | V            | 151.0         | 37                     | -26.2             | 29.2        | 40.0           |
| 172.792500      | 19.7                | 100.0       | V            | 232.0         | 51.3                   | -31.6             | 23.8        | 43.5           |
| 298.972500      | 10.6                | 100.0       | H            | 192.0         | 37.8                   | -27.2             | 35.4        | 46.0           |
| 364.810000      | 24.5                | 100.0       | H            | 16.0          | 50.4                   | -25.9             | 21.5        | 46.0           |
| 874.947500      | 17.3                | 100.0       | H            | 11.0          | 34.3                   | -17.0             | 28.7        | 46.0           |

Remark: 1. Quasi-Peak = Reading value + Correction factor

2. Correction Factor = Insertion loss + Cable loss

3. Margin = Limit - Quasi-Peak

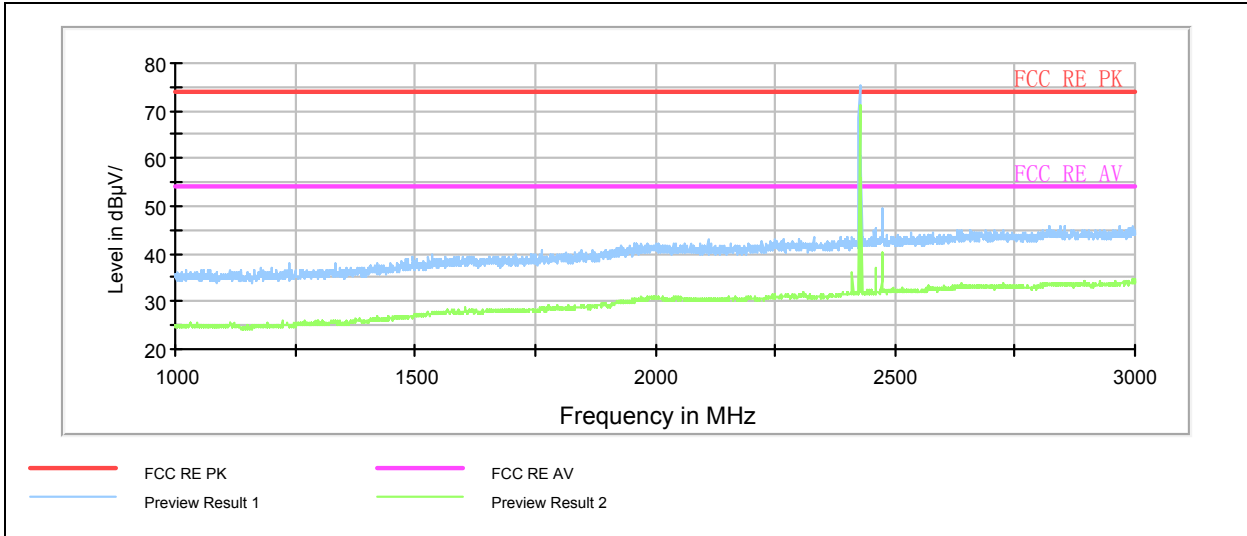

Note: The signal beyond the limit is carrier.  
Radiates Emission from 1GHz to 3GHz

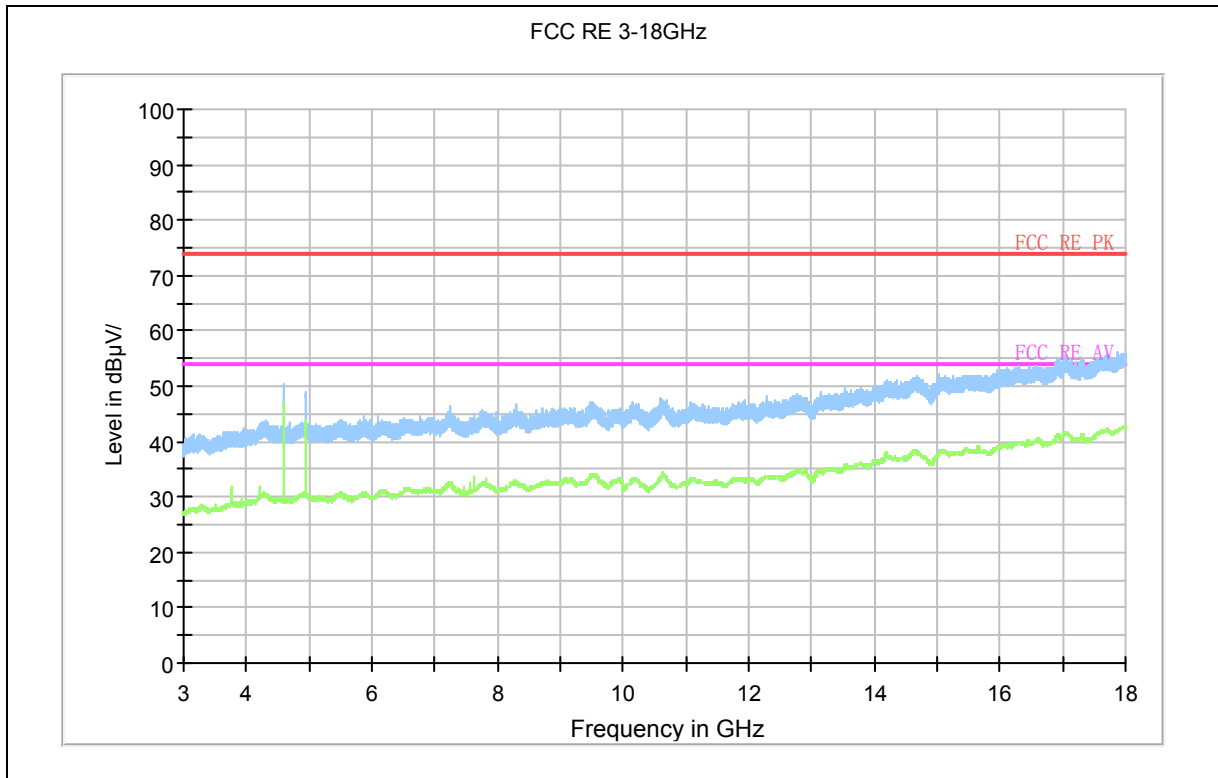

Radiates Emission from 3GHz to 18GHz

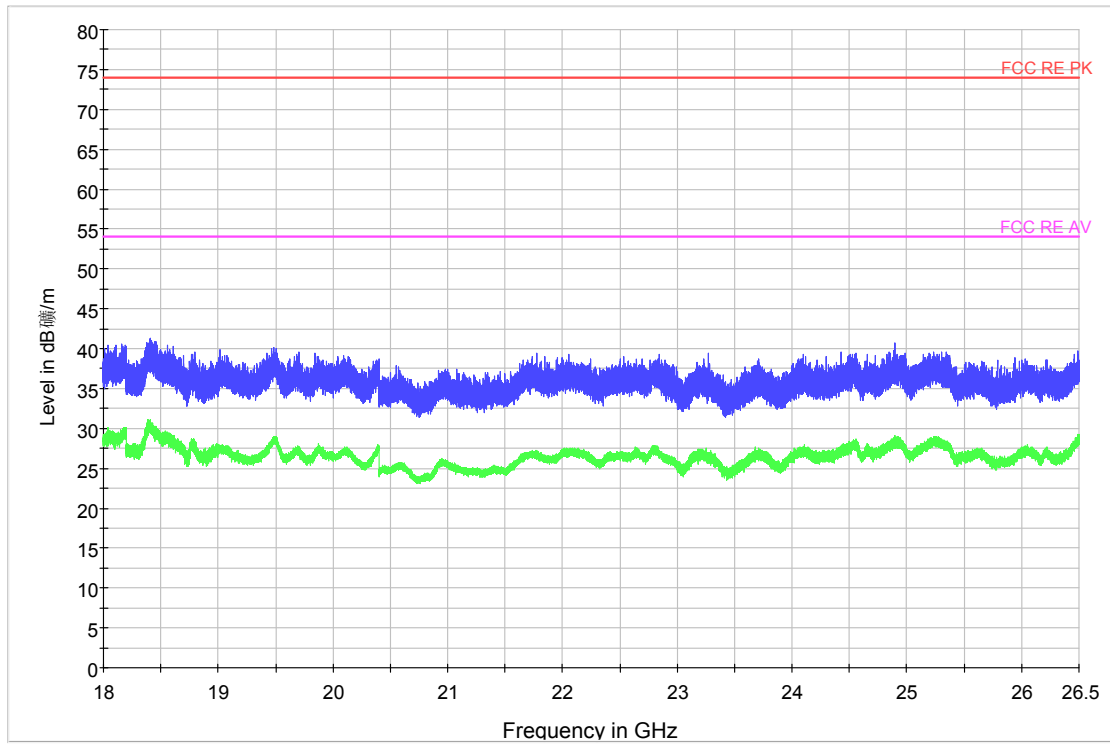

Radiates Emission from 18GHz to 26.5GHz

EDR-Channel 0

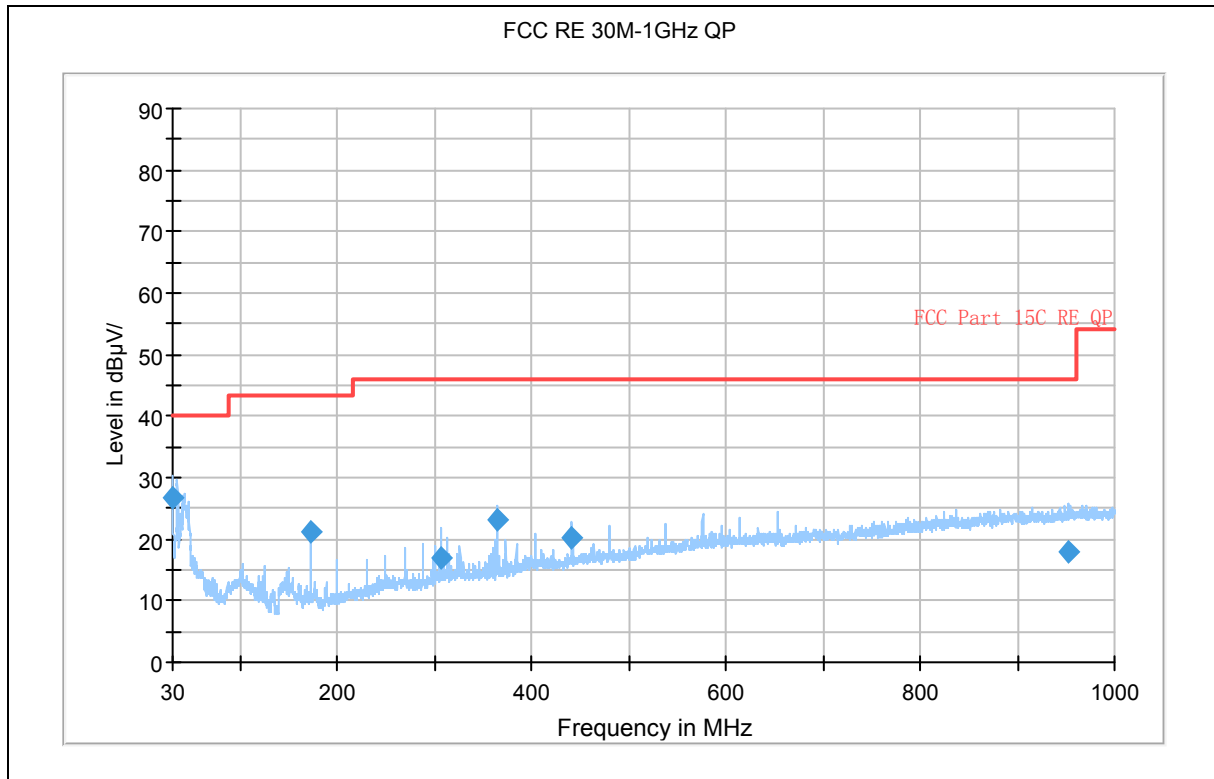

Radiates Emission from 30MHz to 1GHz

| Frequency (MHz) | Quasi-Peak (dBuV/m) | Height (cm) | Polarization | Azimuth (deg) | Reading value (dBuV/m) | Corr. Factor (dB) | Margin (dB) | Limit (dBuV/m) |
|-----------------|---------------------|-------------|--------------|---------------|------------------------|-------------------|-------------|----------------|
| 30.040000       | 26.7                | 100.0       | V            | 11.0          | 50.5                   | -23.8             | 13.3        | 40.0           |
| 172.792500      | 21.1                | 100.0       | V            | 258.0         | 52.7                   | -31.6             | 22.4        | 43.5           |
| 307.177500      | 16.8                | 100.0       | H            | 18.0          | 43.6                   | -26.8             | 29.2        | 46.0           |
| 364.810000      | 23.0                | 100.0       | H            | 33.0          | 48.9                   | -25.9             | 23.0        | 46.0           |
| 441.602500      | 20.2                | 115.0       | V            | 18.0          | 44.3                   | -24.1             | 25.8        | 46.0           |
| 952.395000      | 17.8                | 100.0       | H            | 116.0         | 34.2                   | -16.4             | 28.2        | 46.0           |

Remark: 1. Quasi-Peak = Reading value + Correction factor

2. Correction Factor = Insertion loss + Cable loss

3. Margin = Limit - Quasi-Peak

# TA Technology (Shanghai) Co., Ltd. Test Report

Registration Num:428261

Report No.: RZC1101-0124RF02

Page 69 of 91

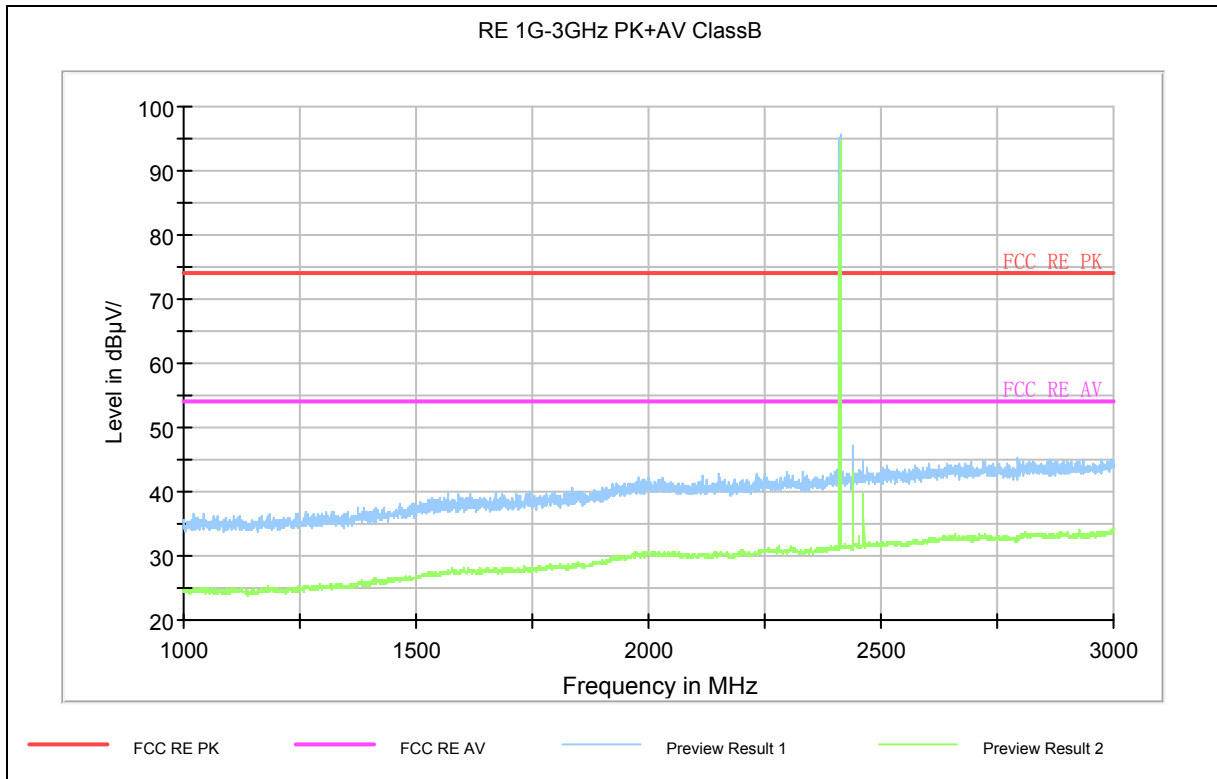

Note: The signal beyond the limit is carrier.  
Radiates Emission from 1GHz to 3GHz

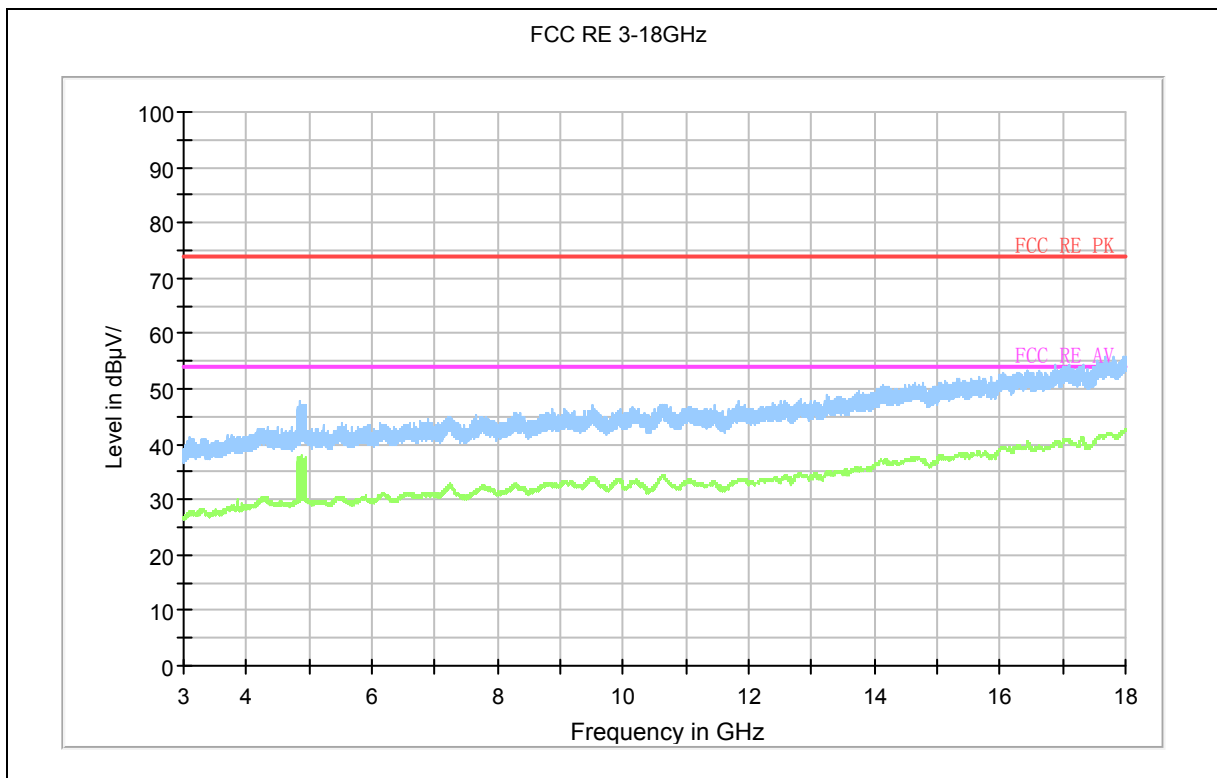

Radiates Emission from 3GHz to 18GHz

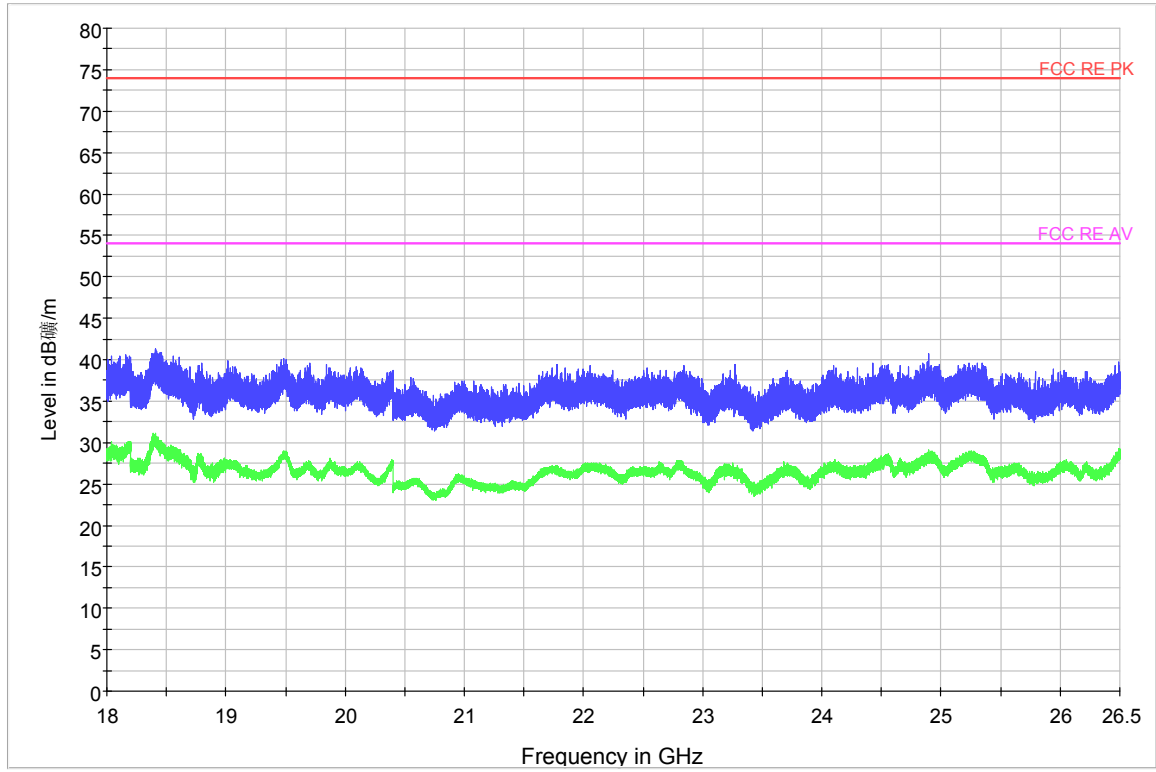

Radiates Emission from 18GHz to 26.5GHz

EDR-Channel 39

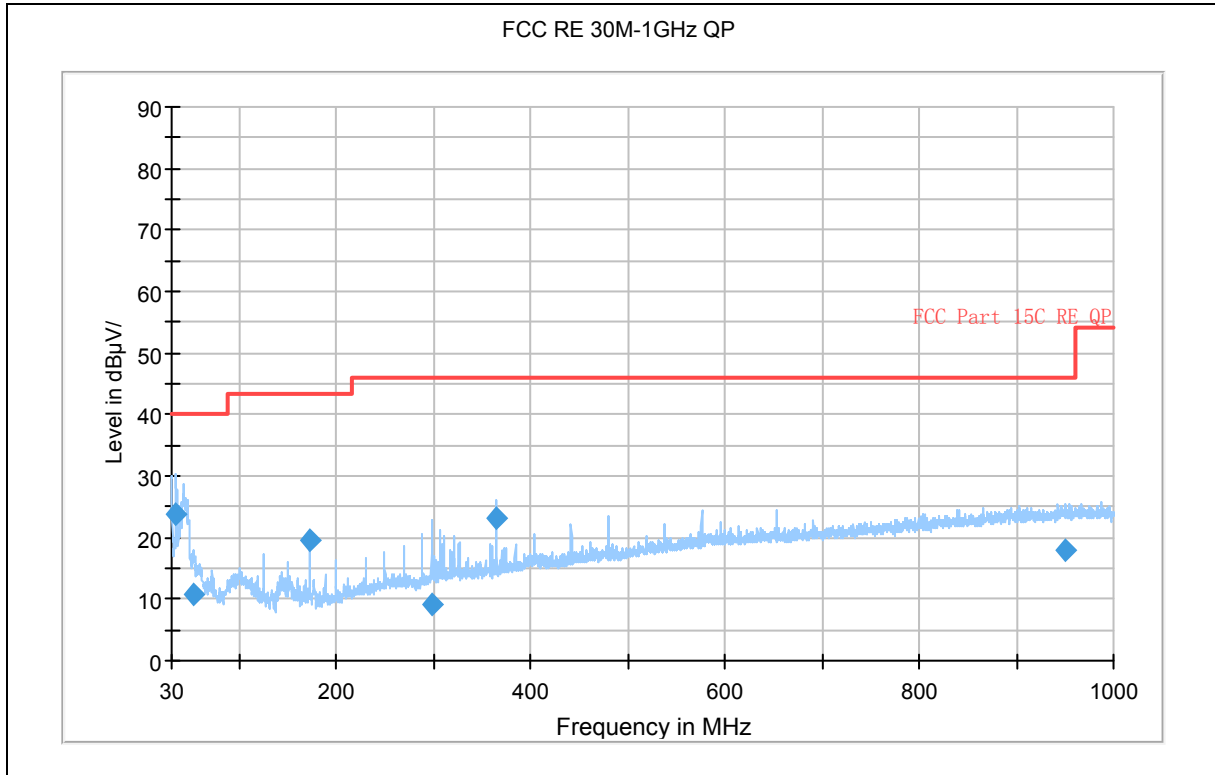

Radiates Emission from 30MHz to 1GHz

| Frequency (MHz) | Quasi-Peak (dBuV/m) | Height (cm) | Polarization | Azimuth (deg) | Reading value (dBuV/m) | Corr. Factor (dB) | Margin (dB) | Limit (dBuV/m) |
|-----------------|---------------------|-------------|--------------|---------------|------------------------|-------------------|-------------|----------------|
| 34.887500       | 23.7                | 100.0       | V            | 54.0          | 48.3                   | -24.6             | 16.3        | 40.0           |
| 53.567500       | 10.8                | 100.0       | V            | 144.0         | 37                     | -26.2             | 29.2        | 40.0           |
| 172.792500      | 19.7                | 100.0       | V            | 236.0         | 51.3                   | -31.6             | 23.8        | 43.5           |
| 298.607500      | 9.0                 | 100.0       | H            | 171.0         | 36.2                   | -27.2             | 37.0        | 46.0           |
| 364.810000      | 23.3                | 100.0       | H            | 34.0          | 49.2                   | -25.9             | 22.7        | 46.0           |
| 950.332500      | 17.8                | 119.0       | V            | 342.0         | 34.2                   | -16.4             | 28.2        | 46.0           |

Remark: 1. Quasi-Peak = Reading value + Correction factor

2. Correction Factor = Insertion loss + Cable loss

3. Margin = Limit - Quasi-Peak

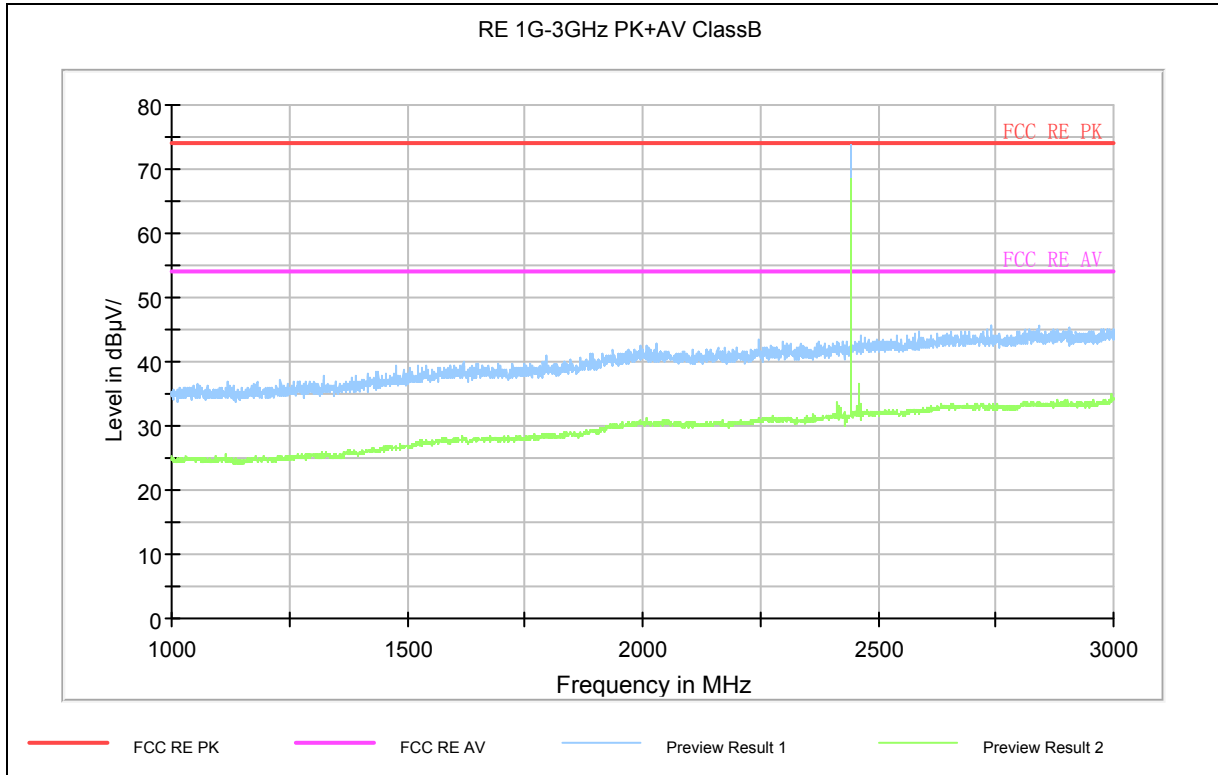

Note: The signal beyond the limit is carrier.  
Radiates Emission from 1GHz to 3GHz

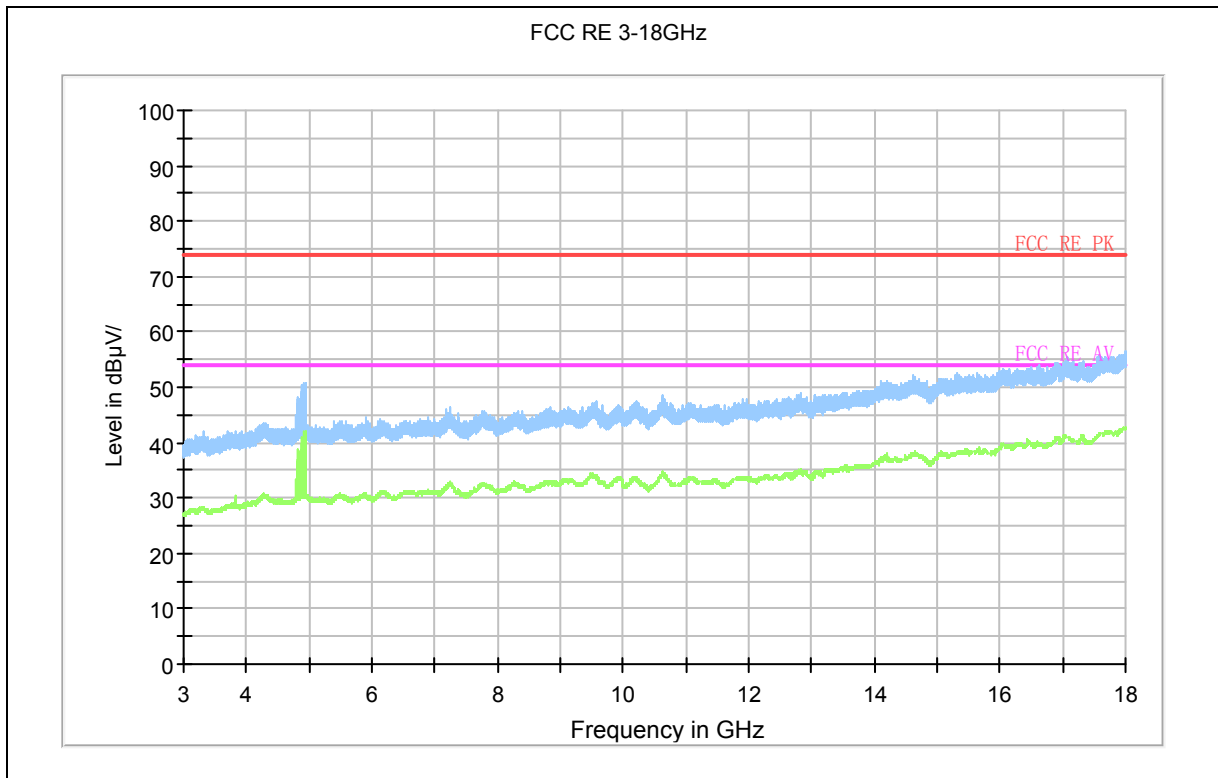

Radiates Emission from 3GHz to 18GHz

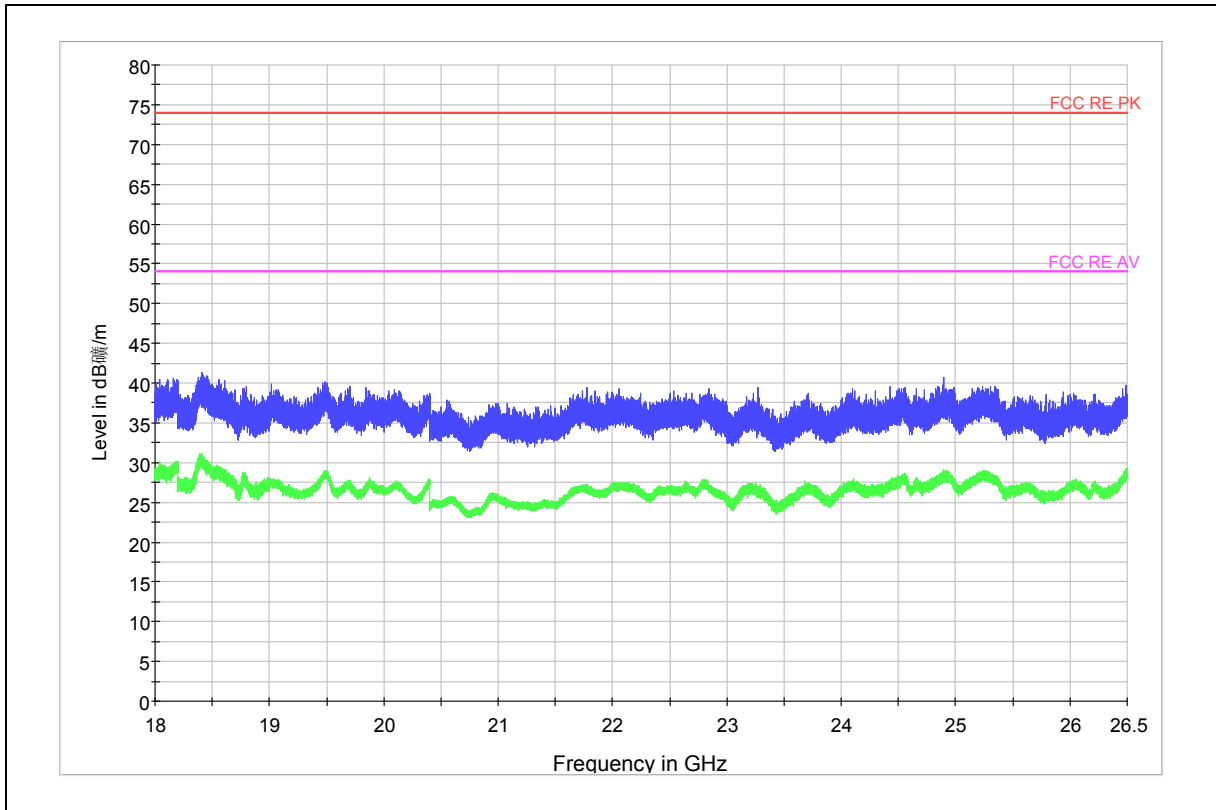

Radiates Emission from 18GHz to 26.5GHz

EDR-Channel 78

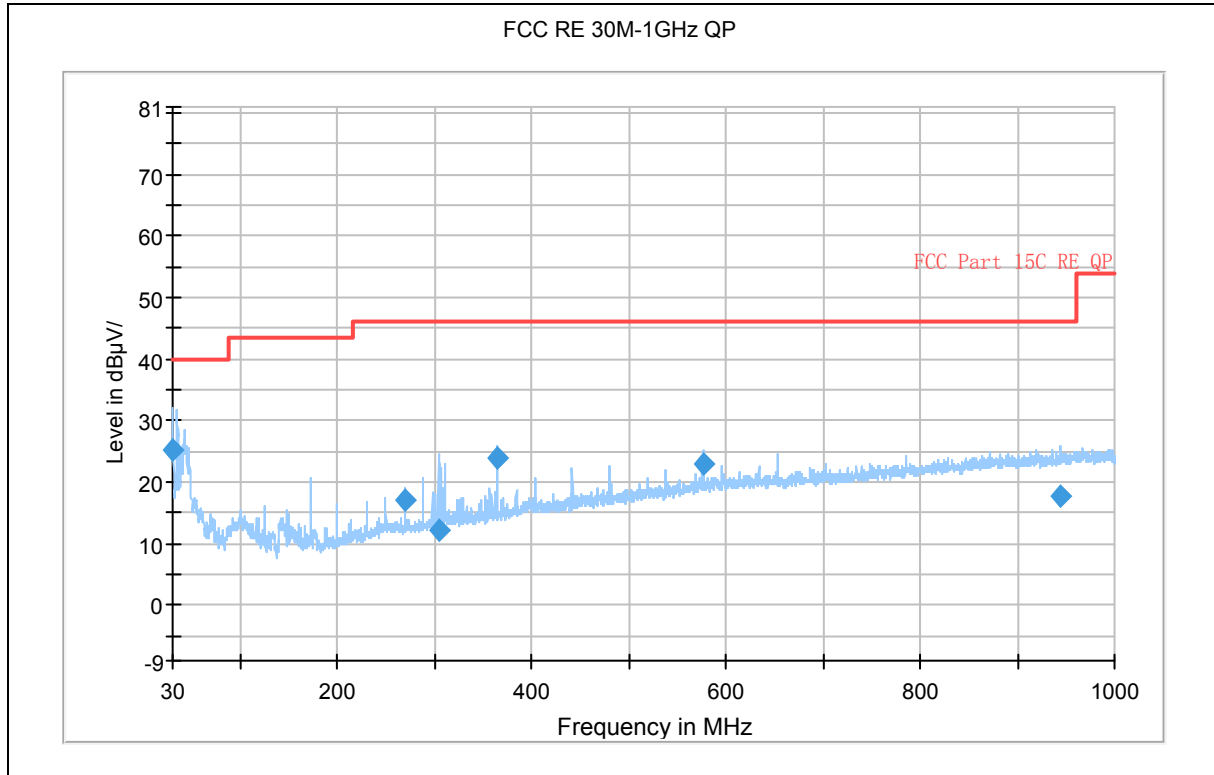

Radiates Emission from 30MHz to 1GHz

| Frequency (MHz) | Quasi-Peak (dBuV/m) | Height (cm) | Polarization | Azimuth (deg) | Reading value (dBuV/m) | Corr. Factor (dB) | Margin (dB) | Limit (dBuV/m) |
|-----------------|---------------------|-------------|--------------|---------------|------------------------|-------------------|-------------|----------------|
| 30.080000       | 25.3                | 100.0       | V            | 0.0           | 49.1                   | -23.8             | 14.7        | 40.0           |
| 268.782500      | 17.1                | 100.0       | H            | 34.0          | 45.2                   | -28.1             | 28.9        | 46.0           |
| 303.580000      | 12.3                | 125.0       | H            | 210.0         | 39.3                   | -27.0             | 33.7        | 46.0           |
| 364.810000      | 23.9                | 100.0       | H            | 16.0          | 49.8                   | -25.9             | 22.1        | 46.0           |
| 575.990000      | 23.0                | 125.0       | H            | 2.0           | 44                     | -21.0             | 23.0        | 46.0           |
| 944.592500      | 17.8                | 125.0       | V            | 50.0          | 34.3                   | -16.5             | 28.2        | 46.0           |

Remark: 1. Quasi-Peak = Reading value + Correction factor

2. Correction Factor = Insertion loss + Cable loss

3. Margin = Limit - Quasi-Peak

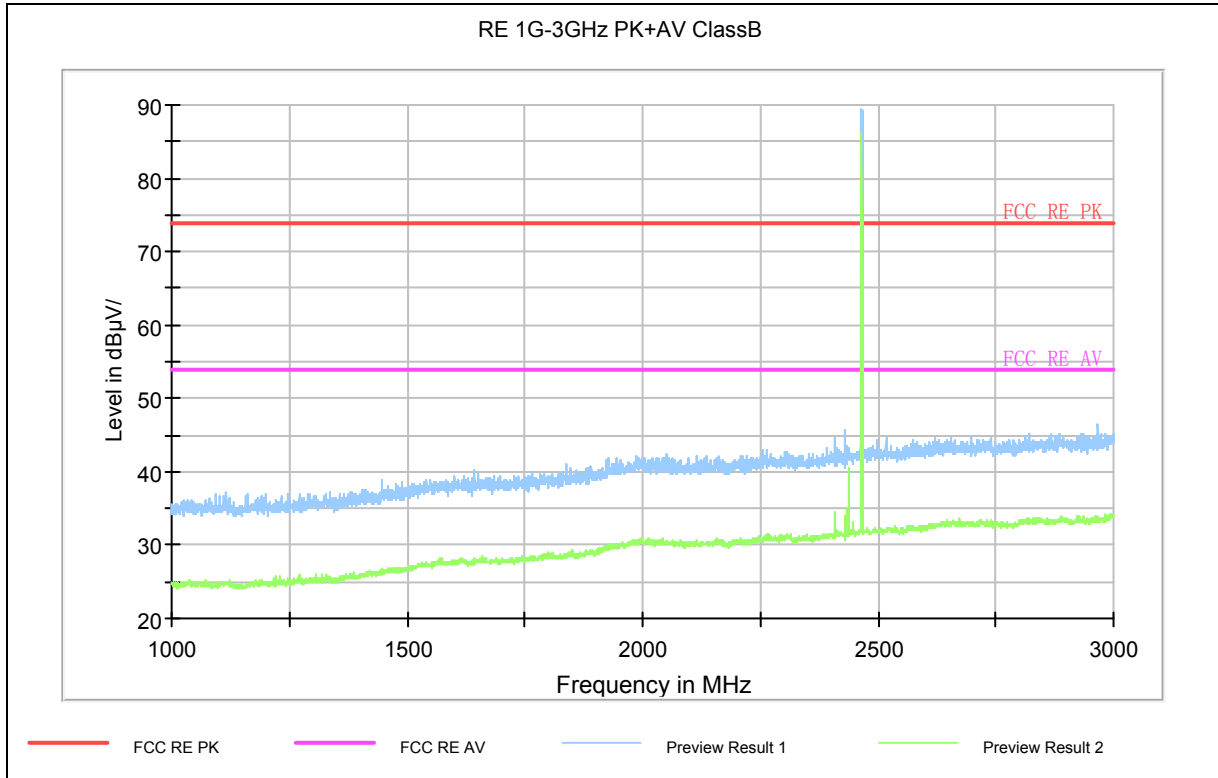

Note: The signal beyond the limit is carrier.  
Radiates Emission from 1GHz to 3GHz

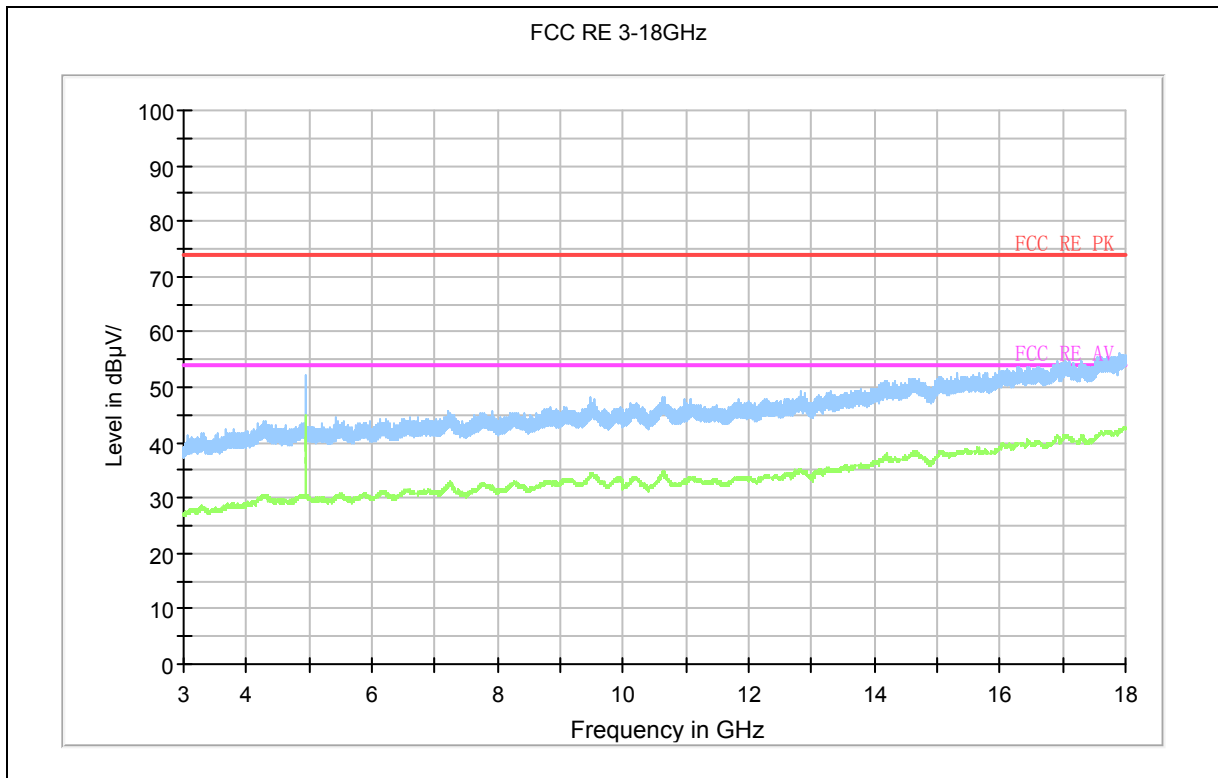

Radiates Emission from 3GHz to 18GHz

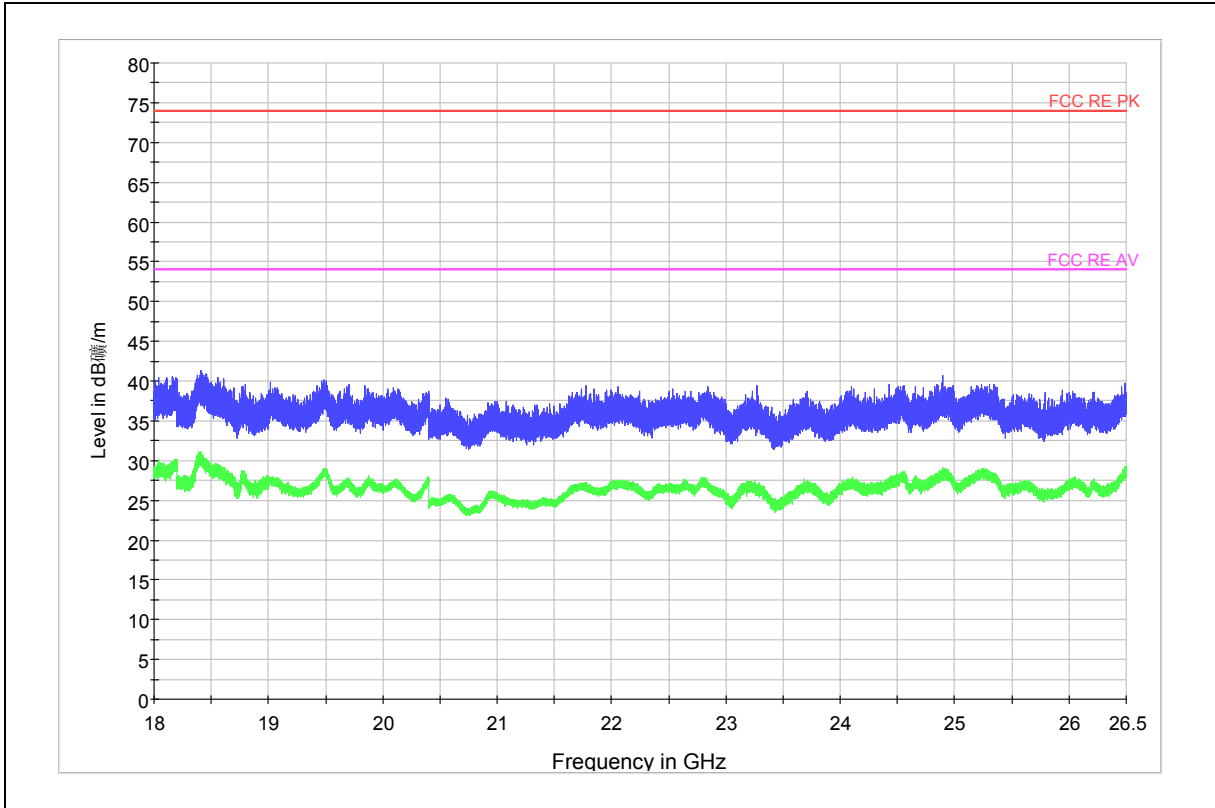

Radiates Emission from 18GHz to 26.5GHz

## 2.11. Conducted Emission

### Ambient condition

|             |                   |          |
|-------------|-------------------|----------|
| Temperature | Relative humidity | Pressure |
| 23°C ~25°C  | 45%~50%           | 101.5kPa |

### Methods of Measurement

The EUT is placed on a non-metallic table of 80cm height above the horizontal metal reference ground plane. During the test, the EUT was operating in its typical mode. The test method is according to ANSI C63.4-2003. Connect the AC power line of the EUT to the L.I.S.N. Use EMI receiver to detect the average and Quasi-peak value. RBW is set to 9kHz,VBW is set to 30kHz.The measurement result should include both L line and N line.

The test is in transmit mode.

### Test Setup

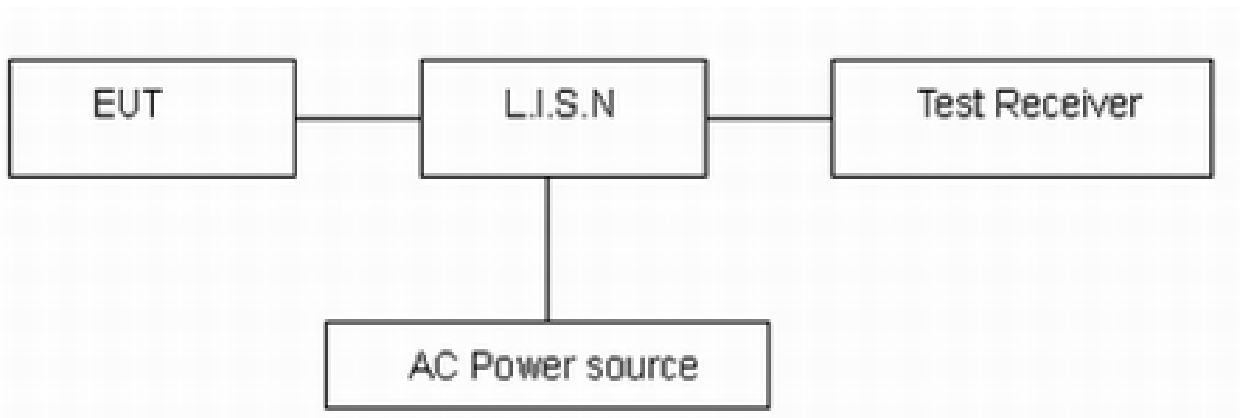

Note: AC Power source is used to change the voltage from 220V/50Hz to 110V/60Hz.

### Limits

| Frequency (MHz) | Conducted Limits(dBμV) |            |
|-----------------|------------------------|------------|
|                 | Quasi-peak             | Average    |
| 0.15 - 0.5      | 66 to 56 *             | 56 to 46 * |
| 0.5 - 5         | 56                     | 46         |
| 5 - 30          | 60                     | 50         |

\*: Decreases with the logarithm of the frequency.

### Measurement Uncertainty

The assessed measurement uncertainty to ensure 95% confidence level for the normal distribution is with the coverage factor  $k = 1.96$ .  $U = 2.69$  dB.

Test Results:

Basic Rate-CH0

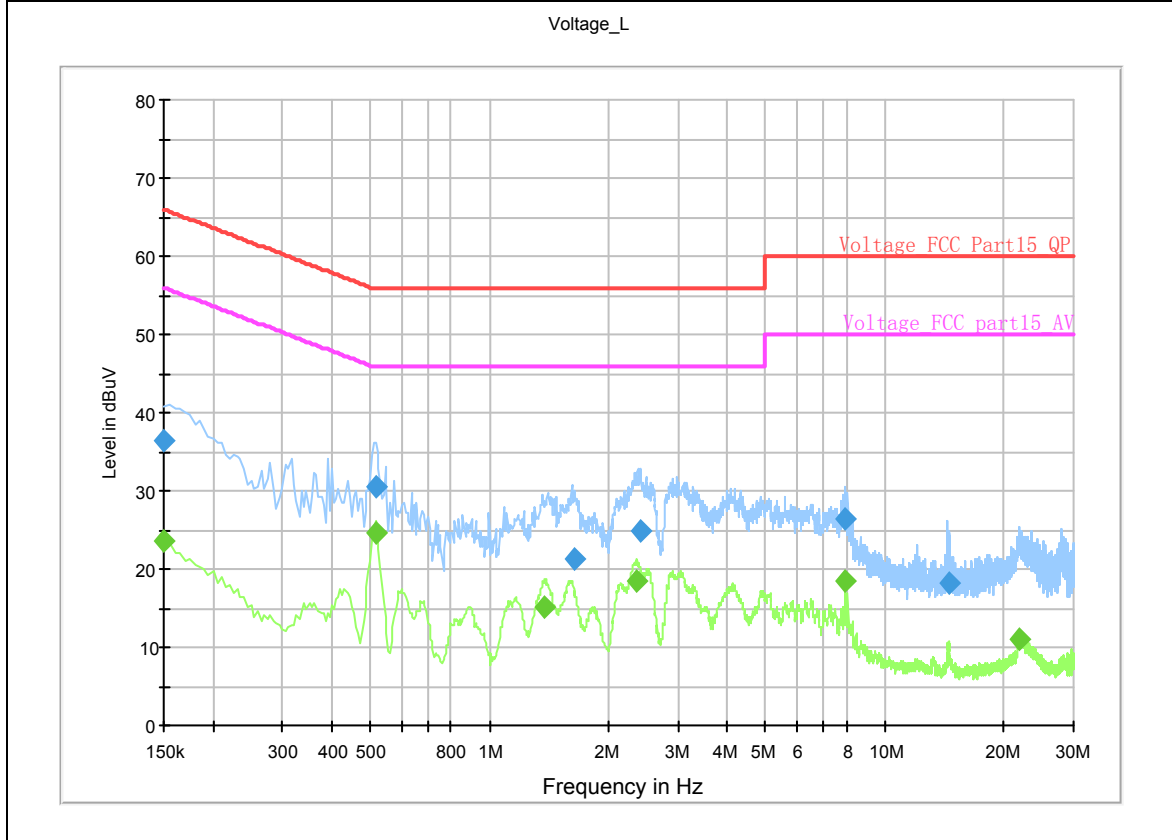

L Line

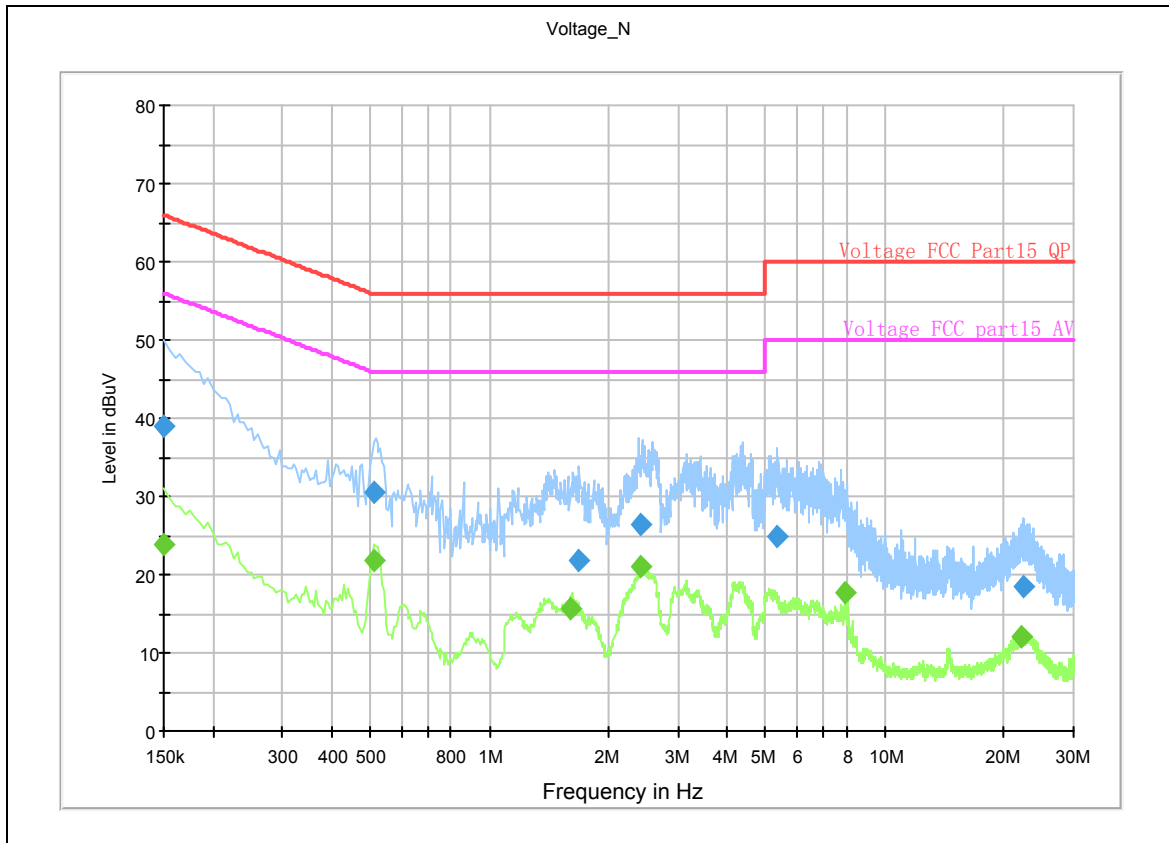

N Line

Conducted Emission from 150 KHz to 30 MHz

| Frequency (MHz) | Detector   | Line | Reading Value(dBμV) | Level (dBμV) | Limit (dBμV) | Margin (dB) | Corr. Factor (dB) |
|-----------------|------------|------|---------------------|--------------|--------------|-------------|-------------------|
| 0.15            | Average    | N    | 14.5                | 24           | 56           | 32          | 9.5               |
| 0.15            | Average    | L    | 14.1                | 23.6         | 56           | 32.4        | 9.5               |
| 0.51            | Average    | N    | 12.1                | 21.8         | 46           | 24.2        | 9.7               |
| 0.515           | Average    | L    | 14.8                | 24.5         | 46           | 21.5        | 9.7               |
| 2.42            | Average    | N    | 11.5                | 21           | 46           | 25          | 9.5               |
| 7.97            | Average    | L    | 8.8                 | 18.5         | 50           | 31.5        | 9.7               |
| 0.15            | Quasi-peak | N    | 29.4                | 38.9         | 66           | 27.1        | 9.5               |
| 0.15            | Quasi-peak | L    | 26.9                | 36.4         | 66           | 29.6        | 9.5               |
| 0.51            | Quasi-peak | N    | 20.7                | 30.4         | 56           | 25.6        | 9.7               |
| 0.515           | Quasi-peak | L    | 20.8                | 30.5         | 56           | 25.5        | 9.7               |
| 2.41            | Quasi-peak | N    | 17                  | 26.5         | 56           | 29.5        | 9.5               |
| 7.97            | Quasi-peak | L    | 16.7                | 26.4         | 60           | 33.6        | 9.7               |

Remark: 1. Level = Reading value + Correction factor

2. Correction Factor = Insertion loss + Cable loss

3. Margin = Limit – Level

Basic Rate-CH39

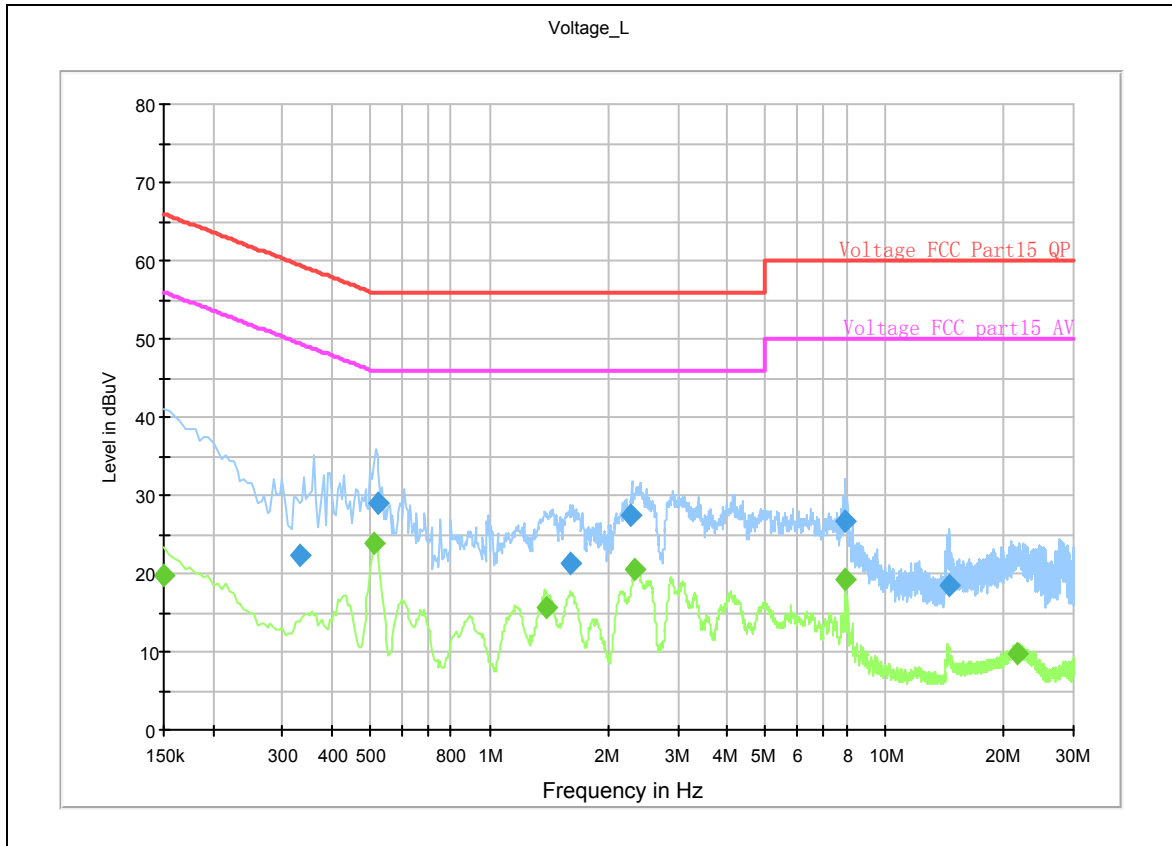

L Line

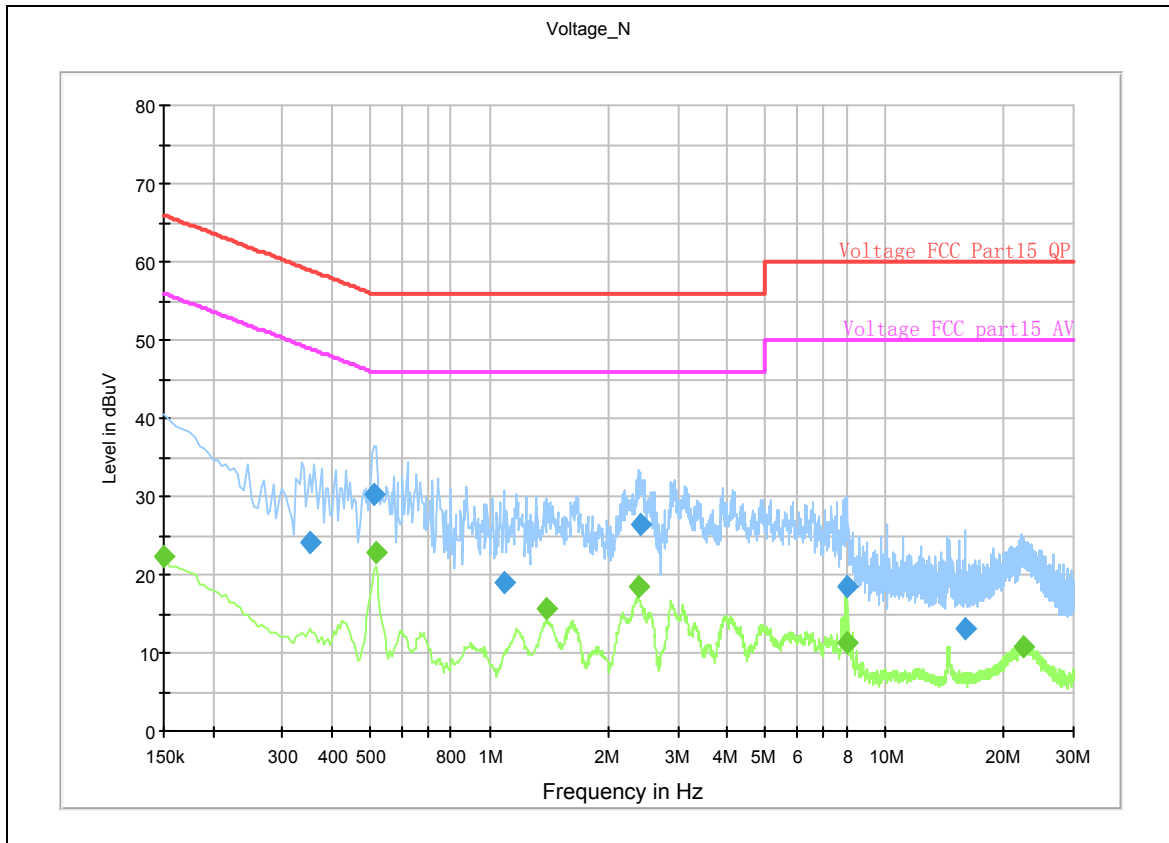

N Line

Conducted Emission from 150 KHz to 30 MHz

| Frequency (MHz) | Detector   | Line | Reading Value(dBμV) | Level (dBμV) | Limit (dBμV) | Margin (dB) | Corr. Factor (dB) |
|-----------------|------------|------|---------------------|--------------|--------------|-------------|-------------------|
| 0.15            | Average    | N    | 12.8                | 22.3         | 56           | 33.7        | 9.5               |
| 0.15            | Average    | L    | 10.4                | 19.9         | 56           | 36.2        | 9.5               |
| 0.51            | Average    | L    | 14                  | 23.7         | 46           | 22.3        | 9.7               |
| 0.515           | Average    | N    | 13.1                | 22.8         | 46           | 23.2        | 9.7               |
| 2.34            | Average    | L    | 11.1                | 20.6         | 46           | 25.4        | 9.5               |
| 7.97            | Average    | L    | 9.5                 | 19.2         | 50           | 30.8        | 9.7               |
| 0.35            | Quasi-peak | N    | 14.4                | 24           | 59           | 35          | 9.6               |
| 0.51            | Quasi-peak | N    | 20.5                | 30.2         | 56           | 25.8        | 9.7               |
| 0.52            | Quasi-peak | L    | 19.3                | 29           | 56           | 27          | 9.7               |
| 2.275           | Quasi-peak | L    | 17.8                | 27.4         | 56           | 28.6        | 9.6               |
| 2.41            | Quasi-peak | N    | 16.9                | 26.4         | 56           | 29.6        | 9.5               |
| 7.97            | Quasi-peak | L    | 17.1                | 26.8         | 60           | 33.2        | 9.7               |

Remark: 1. Level = Reading value + Correction factor

2. Correction Factor = Insertion loss + Cable loss

3. Margin = Limit – Level

Basic Rate-CH78

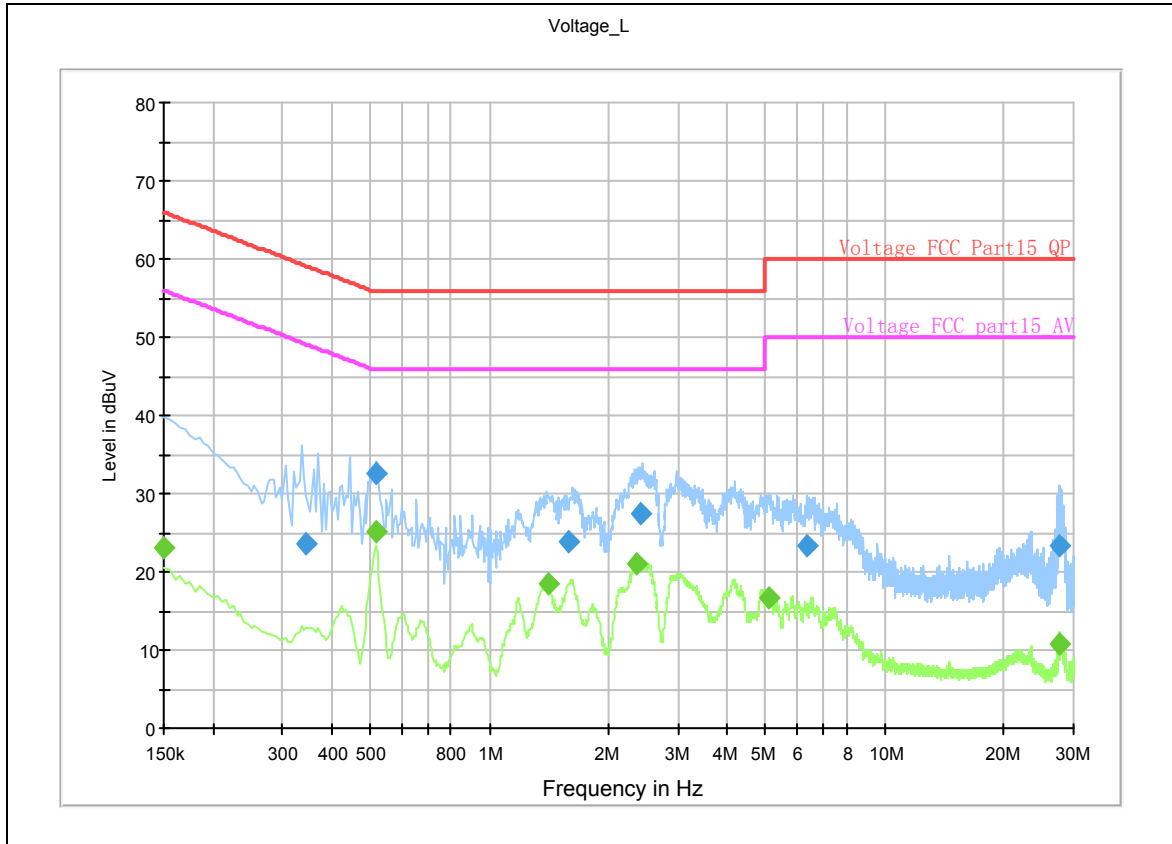

L Line

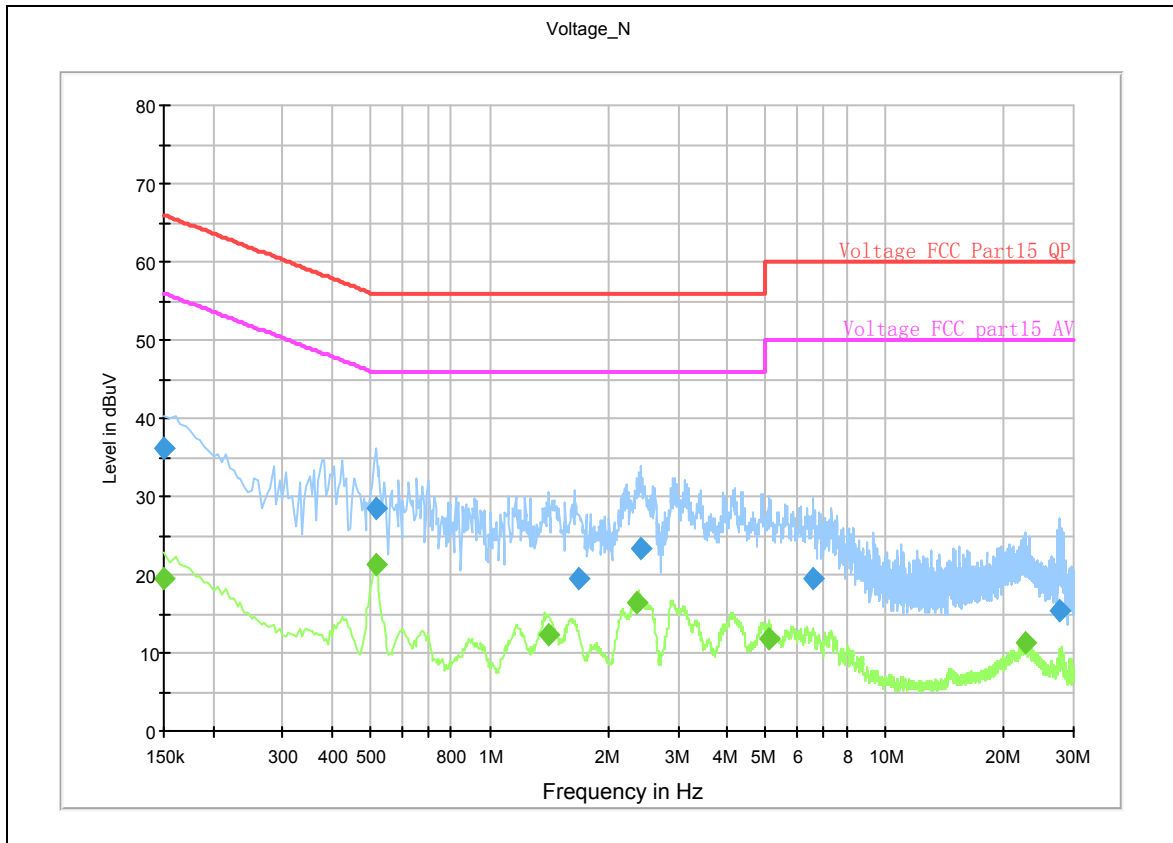

N Line

Conducted Emission from 150 KHz to 30 MHz

| Frequency (MHz) | Detector   | Line | Reading Value(dBμV) | Level (dBμV) | Limit (dBμV) | Margin (dB) | Corr. Factor (dB) |
|-----------------|------------|------|---------------------|--------------|--------------|-------------|-------------------|
| 0.15            | Average    | L    | 13.5                | 23           | 56           | 33          | 9.5               |
| 0.15            | Average    | N    | 10.1                | 19.6         | 56           | 36.4        | 9.5               |
| 0.515           | Average    | L    | 15.3                | 25           | 46           | 21          | 9.7               |
| 0.515           | Average    | N    | 11.7                | 21.4         | 46           | 24.6        | 9.7               |
| 1.41            | Average    | L    | 8.7                 | 18.4         | 46           | 27.6        | 9.7               |
| 2.37            | Average    | L    | 11.6                | 21.1         | 46           | 24.9        | 9.5               |
| 0.15            | Quasi-peak | N    | 26.7                | 36.2         | 66           | 29.8        | 9.5               |
| 0.345           | Quasi-peak | L    | 14                  | 23.6         | 59.1         | 35.5        | 9.6               |
| 0.515           | Quasi-peak | L    | 22.7                | 32.4         | 56           | 23.6        | 9.7               |
| 0.515           | Quasi-peak | N    | 18.7                | 28.4         | 56           | 27.6        | 9.7               |
| 1.59            | Quasi-peak | L    | 14.2                | 23.9         | 56           | 32.1        | 9.7               |
| 2.405           | Quasi-peak | L    | 17.9                | 27.4         | 56           | 28.6        | 9.5               |

Remark: 1. Level = Reading value + Correction factor

2. Correction Factor = Insertion loss + Cable loss

3. Margin = Limit – Level

EDR-CH0

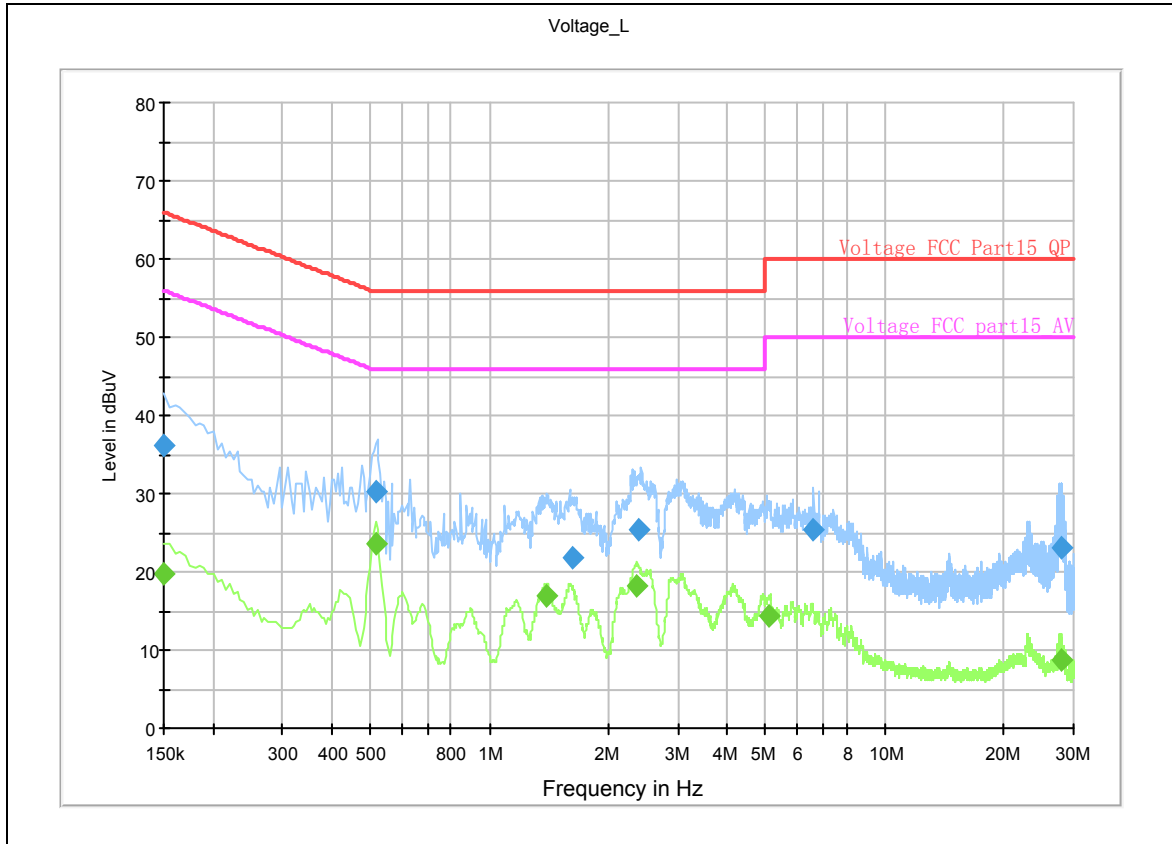

L Line

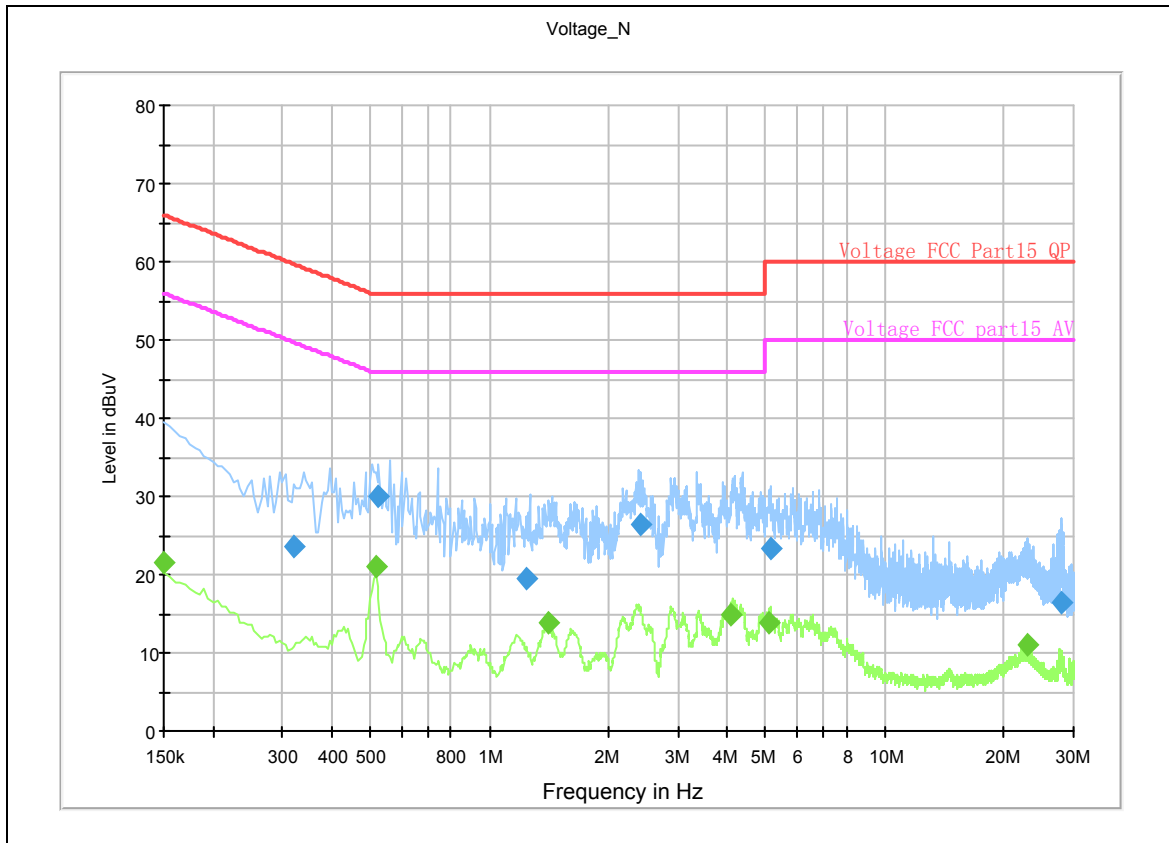

N Line

Conducted Emission from 150 KHz to 30 MHz

| Frequency (MHz) | Detector   | Line | Reading Value(dBμV) | Level (dBμV) | Limit (dBμV) | Margin (dB) | Corr. Factor (dB) |
|-----------------|------------|------|---------------------|--------------|--------------|-------------|-------------------|
| 0.15            | Average    | N    | 12                  | 21.5         | 56           | 34.5        | 9.5               |
| 0.15            | Average    | L    | 10.3                | 19.8         | 56           | 36.2        | 9.5               |
| 0.515           | Average    | L    | 13.8                | 23.5         | 46           | 22.5        | 9.7               |
| 0.515           | Average    | N    | 11.4                | 21.1         | 46           | 24.9        | 9.7               |
| 1.39            | Average    | L    | 7.2                 | 16.9         | 46           | 29.1        | 9.7               |
| 2.355           | Average    | L    | 8.8                 | 18.3         | 46           | 27.7        | 9.5               |
| 0.15            | Quasi-peak | L    | 26.6                | 36.1         | 66           | 29.9        | 9.5               |
| 0.515           | Quasi-peak | L    | 20.6                | 30.3         | 56           | 25.7        | 9.7               |
| 0.52            | Quasi-peak | N    | 20.3                | 30           | 56           | 26          | 9.7               |
| 2.385           | Quasi-peak | L    | 16                  | 25.5         | 56           | 30.5        | 9.5               |
| 2.425           | Quasi-peak | N    | 17                  | 26.5         | 56           | 29.5        | 9.5               |
| 6.605           | Quasi-peak | L    | 15.8                | 25.4         | 60           | 34.6        | 9.6               |

Remark: 1. Level = Reading value + Correction factor

2. Correction Factor = Insertion loss + Cable loss

3. Margin = Limit – Level

EDR-CH39

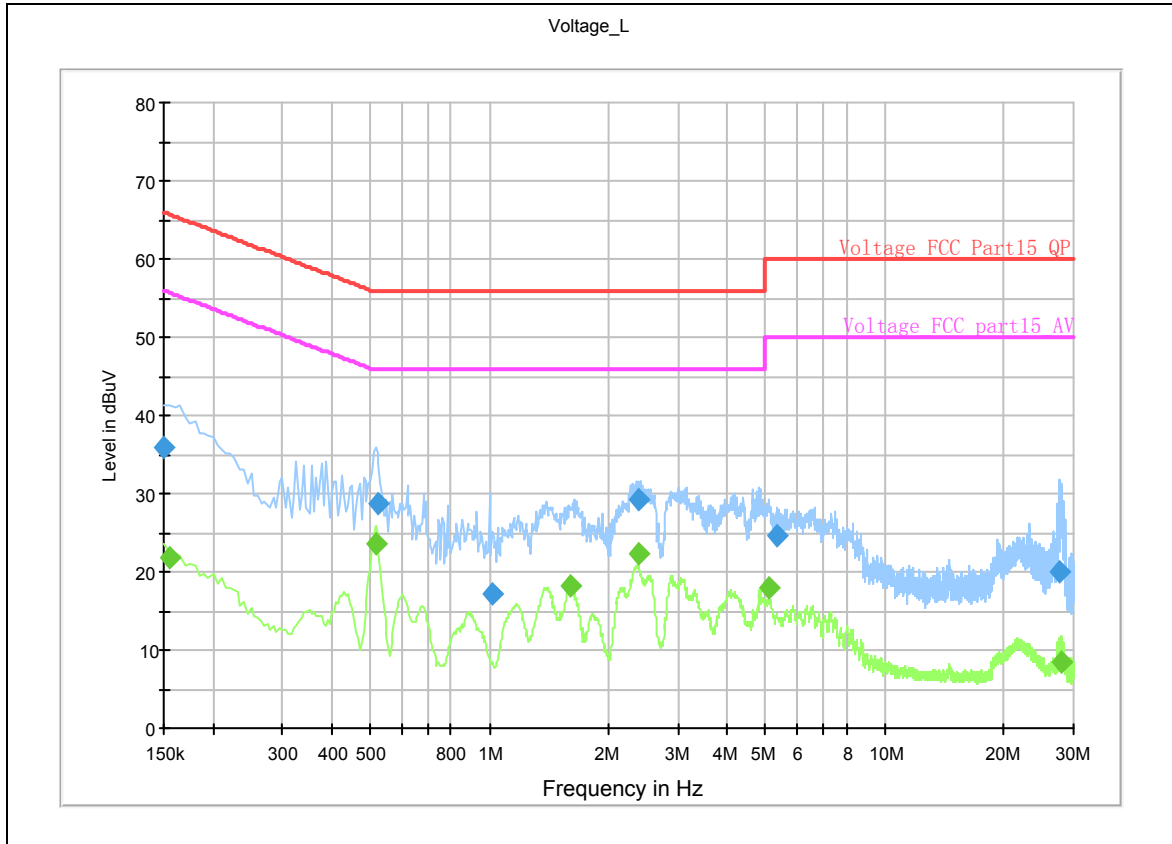

L Line

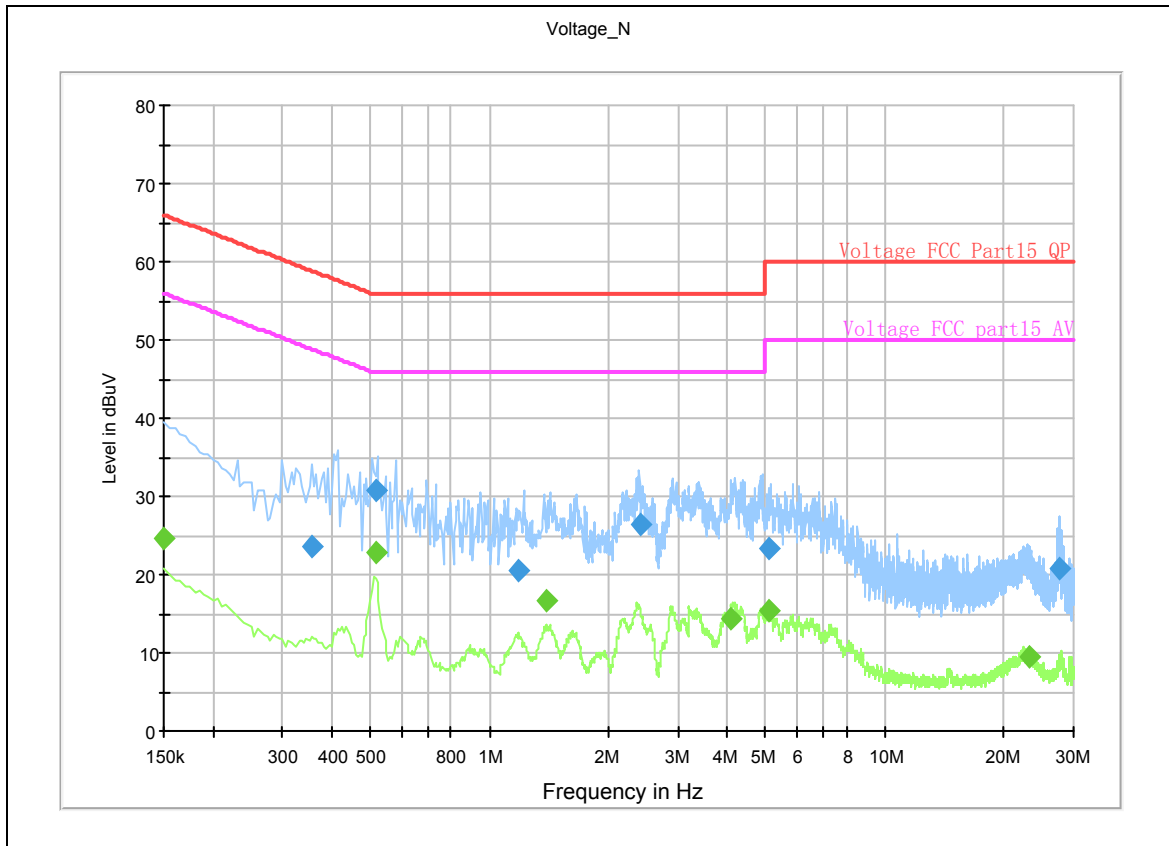

N Line

Conducted Emission from 150 KHz to 30 MHz

| Frequency (MHz) | Detector   | Line | Reading Value(dBμV) | Level (dBμV) | Limit (dBμV) | Margin (dB) | Corr. Factor (dB) |
|-----------------|------------|------|---------------------|--------------|--------------|-------------|-------------------|
| 0.15            | Average    | N    | 15                  | 24.5         | 56           | 31.5        | 9.5               |
| 0.155           | Average    | L    | 12.2                | 21.7         | 55.7         | 34          | 9.5               |
| 0.515           | Average    | L    | 13.9                | 23.6         | 46           | 22.4        | 9.7               |
| 0.515           | Average    | N    | 13.2                | 22.9         | 46           | 23.1        | 9.7               |
| 1.595           | Average    | L    | 8.4                 | 18.1         | 46           | 27.9        | 9.7               |
| 2.375           | Average    | L    | 12.8                | 22.3         | 46           | 23.7        | 9.5               |
| 0.15            | Quasi-peak | L    | 26.3                | 35.8         | 66           | 30.2        | 9.5               |
| 0.515           | Quasi-peak | N    | 21                  | 30.7         | 56           | 25.3        | 9.7               |
| 0.52            | Quasi-peak | L    | 19.1                | 28.8         | 56           | 27.2        | 9.7               |
| 2.38            | Quasi-peak | L    | 19.7                | 29.2         | 56           | 26.8        | 9.5               |
| 2.415           | Quasi-peak | N    | 17                  | 26.5         | 56           | 29.5        | 9.5               |
| 5.36            | Quasi-peak | L    | 15                  | 24.6         | 60           | 35.4        | 9.6               |

Remark: 1. Level = Reading value + Correction factor

2. Correction Factor = Insertion loss + Cable loss

3. Margin = Limit – Level

EDR-CH78

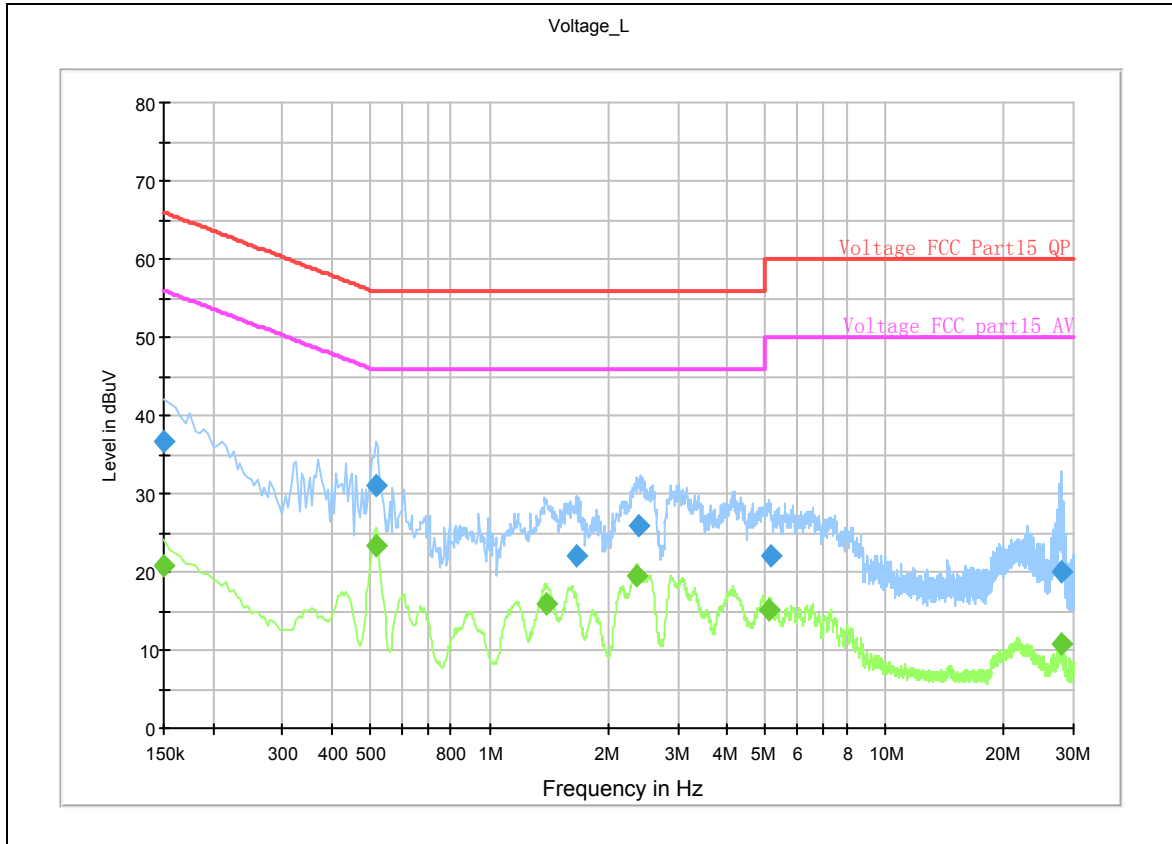

L Line

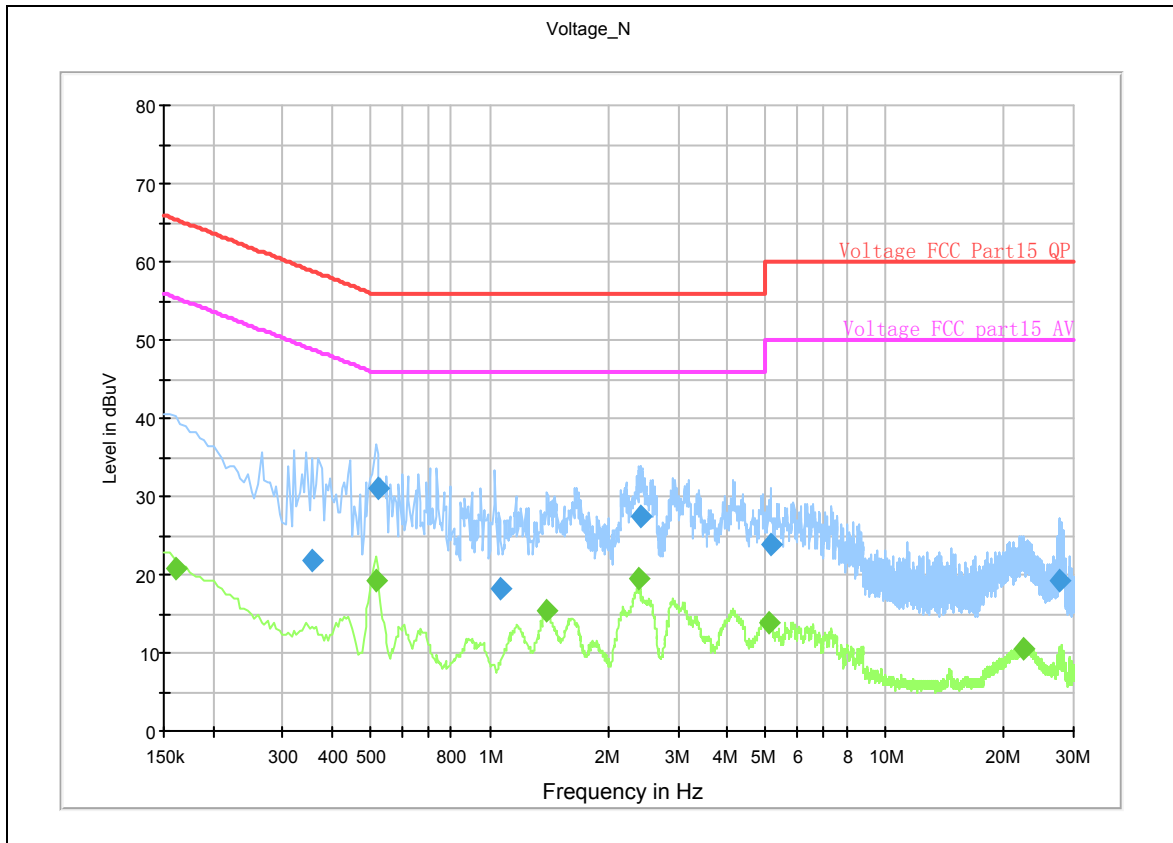

N Line

Conducted Emission from 150 KHz to 30 MHz

| Frequency (MHz) | Detector   | Line | Reading Value(dBμV) | Level (dBμV) | Limit (dBμV) | Margin (dB) | Corr. Factor (dB) |
|-----------------|------------|------|---------------------|--------------|--------------|-------------|-------------------|
| 0.15            | Average    | L    | 11.2                | 20.7         | 56           | 35.3        | 9.5               |
| 0.16            | Average    | N    | 11.2                | 20.8         | 55.5         | 34.7        | 9.6               |
| 0.515           | Average    | L    | 13.6                | 23.3         | 46           | 22.7        | 9.7               |
| 0.515           | Average    | N    | 9.5                 | 19.2         | 46           | 26.8        | 9.7               |
| 2.345           | Average    | L    | 9.9                 | 19.4         | 46           | 26.6        | 9.5               |
| 2.38            | Average    | N    | 9.9                 | 19.4         | 46           | 26.6        | 9.5               |
| 0.15            | Quasi-peak | L    | 27.3                | 36.8         | 66           | 29.2        | 9.5               |
| 0.515           | Quasi-peak | L    | 21.3                | 31           | 56           | 25          | 9.7               |
| 0.52            | Quasi-peak | N    | 21.4                | 31.1         | 56           | 24.9        | 9.7               |
| 2.39            | Quasi-peak | L    | 16.4                | 25.9         | 56           | 30.1        | 9.5               |
| 2.415           | Quasi-peak | N    | 17.8                | 27.3         | 56           | 28.7        | 9.5               |
| 5.14            | Quasi-peak | N    | 14.2                | 23.8         | 60           | 36.2        | 9.6               |

Remark: 1. Level = Reading value + Correction factor

2. Correction Factor = Insertion loss + Cable loss

3. Margin = Limit – Level

### 3. Main Test Instruments

| No. | Name                      | Type         | Manufacturer | Serial Number | Calibration Date | Valid Period |
|-----|---------------------------|--------------|--------------|---------------|------------------|--------------|
| 01  | BT Base Station Simulator | CBT          | R&S          | 100271        | 2010-11-25       | One year     |
| 02  | Signal Analyzer           | FSV          | R&S          | 100815        | 2010-06-28       | One year     |
| 03  | Signal generator          | SMR27        | R&S          | 100365        | 2010-07-01       | One year     |
| 04  | Spectrum Analyzer         | E4445A       | Agilent      | MY46181146    | 2010-06-07       | One year     |
| 05  | EMI Test Receiver         | ESCI         | R&S          | 100948        | 2010-07-01       | One year     |
| 06  | Trilog Antenna            | VULB 9163    | SCHWARZBECK  | 9163-201      | 2010-06-29       | Two years    |
| 07  | Horn Antenna              | HF907        | R&S          | 100126        | 2009-07-02       | Two years    |
| 08  | AC Power Source           | AFC-11005G   | APC          | F309040118    | 2009-08-03       | Three years  |
| 09  | Power Splitter            | 11667A       | Agilent      | 52960         | NA               | NA           |
| 10  | Semi-Anechoic Chamber     | 9.6*6.7*6.6m | ETS-Lindgren | NA            | NA               | NA           |
| 11  | EMI test software         | ES-K1        | R&S          | NA            | NA               | NA           |

\*\*\*\*\*END OF REPORT BODY\*\*\*\*\*

**TA Technology (Shanghai) Co., Ltd.**  
**Test Report**

Registration Num:428261

Report No.: RZC1101-0124RF02

Page 91 of 91

---

**ANNEX A: EUT Appearance and Test Setup**