



**MOTOROLA**

## HAC Test Report IHDT56EU3

**Date of test:** 8/19/2005  
**Date of Report:** 9/2/2005

**Laboratory:** Motorola Mobile Devices Business Product Safety & Compliance Laboratory  
600 N. US Highway 45  
Room: MW113  
Libertyville, Illinois 60048

**Test Responsible:** Scott Kelley  
Disability Access Manager

**Statement of Compliance:** Motorola declares under its sole responsibility that portable cellular telephone FCC IHDT56EU3 to which this declaration relates, complies with recommendations and guidelines FCC 47 CFR §20.19. The measurements were performed to ensure compliance to the ANSI PC63.19-2001 rd 3.6 standard. It also declares that the product was tested in accordance with the appropriate measurement standards, guidelines and recommended practices. Any deviations from these standards, guidelines and recommended practices are noted below:

(none)

**Results Summary:** **Max E Field emission = 60.5 V/m @ 1850 MHz**  
**Max H Field emission = 0.157 A/m @ 1910 MHz**  
**M Category = M3**



©Motorola, Inc. 2005

This test report shall not be reproduced except in full, without written approval of the laboratory.

The results and statements contained herein relate only to the items tested. The names of individuals involved may be mentioned only in connection with the statements or results from this report.

Motorola encourages all feedback, both positive and negative, on this test report.

**Table of Contents**

**1. INTRODUCTION .....3**

**2. DESCRIPTION OF THE DEVICE UNDER TEST.....3**

**3. TEST EQUIPMENT USED.....3**

**4. SYSTEM ACCURACY VERIFICATION.....4**

**5. PROBE MODULATION FACTOR .....5**

**6. TEST RESULTS.....6**

**APPENDIX 1: HAC DISTRIBUTION PLOTS FOR SYSTEM ACCURACY VERIFICATION .....9**

**APPENDIX 2: HAC DISTRIBUTION PLOTS FOR E-FIELD AND H-FIELD .....12**

**APPENDIX 3: MEASUREMENT UNCERTAINTY BUDGET.....15**

**A3.1 Motorola Uncertainty Budget for RF HAC Testing .....16**

**A3.2 Probe Rotation Contributions to Isotropy Error .....16**

**APPENDIX 4: PICTURES OF TEST SETUP .....17**

**APPENDIX 5: PROBE CALIBRATION CERTIFICATES.....19**

**1. Introduction**

The Motorola Mobile Devices Business Product Safety Laboratory has performed Hearing Aid Compatibility (HAC) measurements for the portable cellular phone (FCC ID IHDT56EU3). The portable cellular phone was tested in accordance with ANSI PC63.19-2001 rd 3.6 standard. The test results presented herein clearly demonstrate compliance FCC 47 CFR § 20.19. This report demonstrates compliance for near field emissions only and not for the T-coil performance compliance.

**2. Description of the Device Under Test**

**Table 1: Information for the Device Under Test**

<b>FCC ID Number</b>	<b>IHDT56EU3</b>						
<b>Serial number</b>	LRZ0420029						
<b>Mode(s) of Operation*</b>	GSM 900	GSM 1800	GSM 1900	GPRS 900	GPRS 1800	GPRS 1900	Blue Tooth
<b>Modulation Mode(s)</b>	GSM	GSM	GSM	GSM	GSM	GSM	Blue Tooth
<b>Maximum Output Power Setting</b>	33.00 dBm	30.00 dBm	30.00 dBm	33.00 dBm	30.00 dBm	30.00 dBm	0 dBm
<b>Duty Cycle</b>	1:8	1:8	1:8	2:8	2:8	2:8	1:1
<b>Transmitting Frequency Rang(s)</b>	880.2-914.8 MHz	1710.2-1784.8 MHz	1850.20 - 1909.80 MHz	880.2-914.8 MHz	1710.2-1784.8 MHz	1850.20 - 1909.80 MHz	2400 - 2483.5 MHz
<b>Production Unit or Identical Prototype (47 CFR §2.908)</b>	Identical Prototype						
<b>Device Category</b>	Portable						

\* The composite DSS is a Part 15c low power (class 2) Bluetooth device. This secondary transmitter was not enabled during testing, since the intended use of the PCS transmitter does not include simultaneous operation when held to ear.

**3. Test Equipment Used**

The Motorola Mobile Devices Business Product Safety & Compliance Laboratory utilizes a Dosimetric Assessment System (Dasy4™ v4.5) manufactured by Schmid & Partner Engineering AG (SPEAG™), of Zurich Switzerland. All the HAC measurements are taken within a shielded enclosure. The measurement uncertainty budget is given in Appendix 6. The list of calibrated equipment used for the measurements is shown below.

**Table 2: Dosimetric System Equipment**

<b>Description</b>	<b>Serial Number</b>	<b>Cal Due Date</b>
DAE3	SN378	7/8/2006
E-Field Probe ER3DV6R	SN2247	7/20/2006
H-Field Probe H3DV6	SN6074	7/8/2006
Planar Dipole 1880 MHz	P1880-003	

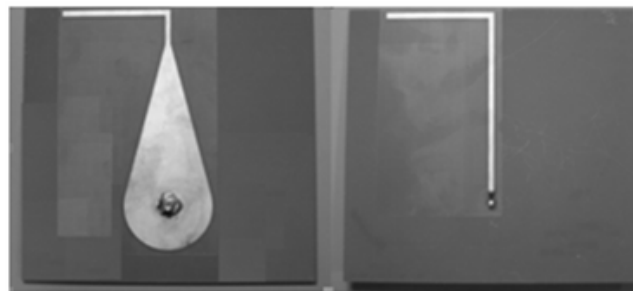
**Table 3: Additional Test Equipment**

Description	Serial Number	Cal Due Date
Signal Generator E4432B	GB38450359	2/22/2006
3db Attenuator	50579	12/27/2005
Power Supply 6632B	01N992	12/17/2005
Directional Coupler 778D	18610	03/24//2006
Power Meter E4416A	GB41293246	2/25/2006
Power Meter E4419B	GB39511086	03/22//2006
Power Sensor #1 – E9301A	US39211013	12/28/2005
Power Sensor #2 - E9323A	US40412053	2/18/2006

**4. System Accuracy Verification**

A system accuracy verification of the DASY4 v4.5 test system was performed using the measurement equipment listed in Section 3.1. The weekly system accuracy verification occurs in free space. Note that the 1cm probe to dipole separation is measured from the top edge of the dipole to the calibration reference point of the probe. This reference point was used for system validation only, which is the center point of the probe sensor. This is justified because the targets for planar dipoles published in C63.19 were derived via theoretical numerical analysis from FDTD using the calibration point of the probe sensors (ie – the center of the sensors). Therefore, when using these targets, it is appropriate to measure the 10mm separation distance to the center of the sensors. The highest voltage measured during the scan was 0.711 mV. This occurred on the X channel. The diode compression point for this channel is at 97 mV. Thus the measurement was taken below the compression point.

Dipoles used were the planar dipoles described in section 4.2.2.1.4 of the validation procedure and exemplified in Annex D.5.2 of the standard. The photograph from this annex is included in Figure 1 below for quick reference. Because these dipoles are the exact specification of the planar dipoles used to develop the targets in the standard, the exact target values listed in Table 4-1 of the standard for planar dipoles are in fact appropriate for this specific case and were used in this application.



**Figure 1: Example of Freespace Planar Dipole used in Motorola Validations**

Measurements were performed to see if the measured E-field and H-field values were within +/- 25% from the Planar Dipole target values indicated in ANSI PC63.19-2001 RD 3.6. These tests were done at 835 MHz and/or 1880 MHz. These frequencies are within each operating band and are within 2MHz of the mid-band frequency of the test device. The obtained results from the system accuracy verification are displayed in the table below. The Field contour plots are included in Appendix 1.

Per Section 4.2.2.1 of the C63.19 standard, “Values within +/-25% are acceptable, of which 12% is deviation and 13% is measurement uncertainty.” The E- and H- dipole verification deviation measurements for E- and H- were 11.6% and 9.6%, respectively, which are in complete accordance with the acceptable parameters defined by the standard.

**Table 4: Dipole Measurement Summary**

F (MHz)	Input Power (W)	Input Power (mW)	E-Field Results (V/m)	C63.19 Target (V/m)	% Deviation
1880	CW Measured, 8/15/2005	100	135.8	153.6	-11.6

F (MHz)	Input Power (W)	Input Power (mW)	H-Field Results (A/m)	C63.19 Target (A/m)	% Deviation
1880	CW Measured, 8/15/2005	100	0.405	0.4478	-9.6

**5. Probe Modulation Factor**

After every probe calibration, the modulated signal (CDMA, GSM, etc) and CW are performed at 835 MHz and 1880 MHz. The response of the probe system to a CW field at the frequency(s) of interest is compared to its response to a modulated signal with equal peak amplitude. The peak power was measured substituting the CW signal with a GSM signal at the intended frequency using a Signal Generator. With a peak power meter the peak amplitude of the GSM signal was set equal to the amplitude of the CW signal.

Probe modulation factor (PMF) refers to the ratio of the CW signal measurement to the modulated signal measurement. For GSM, the PMF can be seen to be implemented in the DASY4 scans in Appendix 2 via the Crest Factor setting (Crest Factor =  $PMF^2$ ). Due to limitations in the current DASY4 crest factor setting (setting can not be less than unity), for CDMA the PMF is applied later to the appropriate phone’s measurements in Section 6.1 via the formula Peak Field =  $20 * \log(Raw * PMF)$ .

RF Field Probe Modulation Response was measured with the field probe and associated measurement equipment. The PMF was measured per ANSI PC63.19-2001 RD 3.6 using signal generator as follows:

1. Illuminate a dipole with a CW signal at the intended measurement frequency.
2. The probe was fixed at a set location relative to the dipole; located at the interpolated maximum of an area scan.
3. Record the reading of the probe measurement system of the CW signal.
4. Substitute a modulated signal of the same amplitude, using the same modulation as that used by the intended WD for the CW signal.
5. Record the reading of the probe measurement system of the modulated signal.
6. The ratio of the CW to modulated signal reading is the probe modulation factor.

**Table 5: PMF Measurement Summary**

f (MHz)	Protocol	Peak Power (mW)	E-Field Probe SN 2247		H-Field Probe SN 6074	
			E-Field (V/m)	E-Field Modulation Factor	H-Field (A/m)	H-Field Modulation Factor
1880	CW	100	145.7	3.05	0.4419	2.96
	GSM	100	47.7		0.1495	

**6. Test Results**

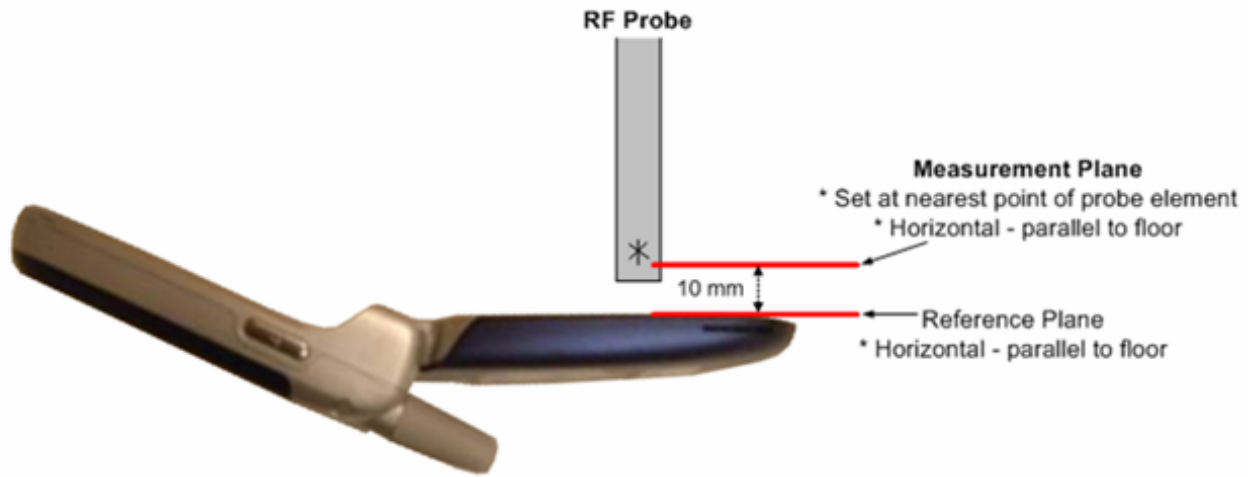
The phone was tested in all normal configurations for the ear use. When applicable, each configuration is tested with the antenna in its fully extended and fully retracted positions. These test configurations are tested at the high, middle and low frequency channels of each applicable operating mode; for example, GSM, CDMA, and TDMA.

The DASY4 v4.5 measurement system specified in section 3.1 was utilized within the intended operations as set by the SPEAG™ setup. The default settings for the grid spacing of the scan were set to 5mm as shown in the Field plots included in Appendix 2 and 3.

The 5cm x 5cm area measurement grid is centered on the acoustic output of the device. The WD reference plane is parallel to the device and contains the highest point on its contour in the area of the phone that normally rests against the user's ear. The device is positioned such that the WD reference plane is located 10mm from, and parallel to, the measurement plane. The measurement plane is set at the bottom point of the probe sensor at a distance of 10mm from the WD. The distance from this device reference point to the measurement plane is established by inserting the appropriate height offset value (Z) in the DASY4 HAC scan. This is in accordance with section 4.3 of the standard, which states that “The WD reference plane is a plane parallel with the front "face" of the WD and containing the highest point on its contour in the area of the phone that normally rests against the user's ear.” The following figures show the orientation of the measurement grid with respect to the device under test.

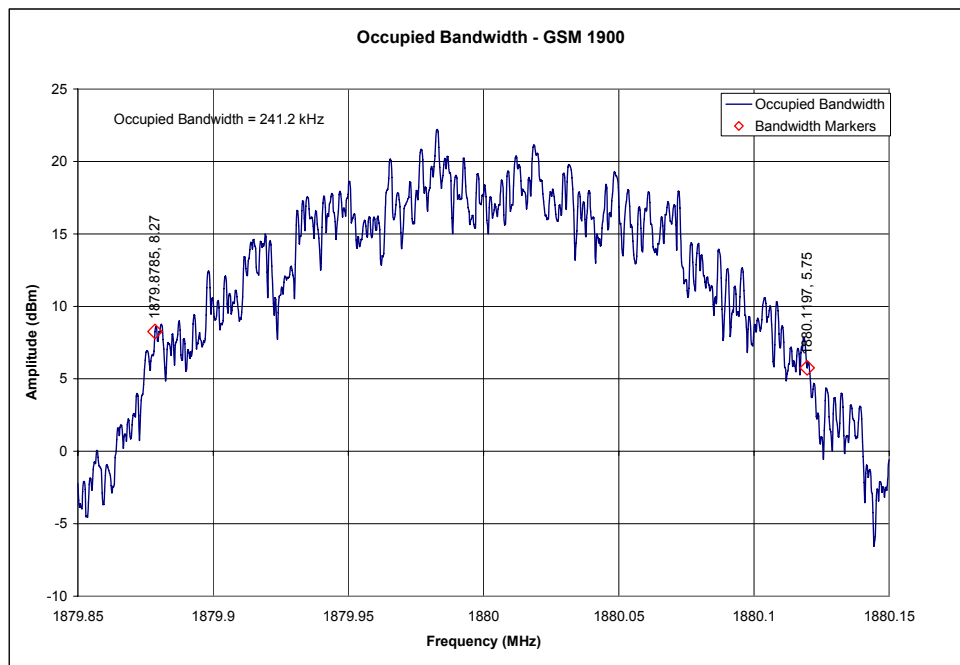


**Figure 2: Orientation of Wireless Device and Measurement Plane**



**Figure 3: Clarification of Figure A-2 from the Standard**

The WD’s signal is the typical GMSK modulated signal used for GSM calls and connections in a cellular network. Figure 4 below shows a wideband spectrum analyzer plot.



**Figure 4: GSM 1900 Frequency Scan**

The signal was setup by creating and maintaining an over the air connection between the DUT and an Agilent 8960 Wireless Communications Test Set. This allows direct control over the DUT’s transmit channel, power step and data rate. This DUT is capable of only GMSK and 8PSK modulations and is not capable of any CDMA modes

The E-Field and H-Field maximum values are shown in tables 6 and 7. Also shown are the measured conducted output powers, the measured drift, excluded area, and the measured field strength. Drift was measured using the typical DASY4 v4.5 measurement routines. The field is measured at the reference location (center of the ear piece) at the beginning of the test. Then after completion of the E or H field measurement, the probe returns to the same reference location and takes another measurement. The drift is the delta between these two values and is included in the test report scans. PMF measurement is taken from Section 5. Per Section 5, for GSM phones the PMF can be seen to be implemented in the DASY4 scans in Appendix 2 via the Crest Factor setting (Crest Factor =  $PMF^2$ ).

Due to limitations in the current DASY4 crest factor setting (setting can not be less than unity), for CDMA phones the PMF is applied later to the appropriate phone’s measurements in Section 6.1 via the formula Peak Field = 20 \* log (Raw \* PMF). The worst-case test conditions are indicated with **bold numbers** in the following table and are detailed in Appendix 2: HAC distribution plots for E-Field and H-Field.

**Table 6: HAC E-Field measurement results for the portable cellular telephone  
FCC ID IHDT56EU3 at highest possible output power.**

Frequency Band (MHz)	Antenna position	Channel Setting	Conducted Output Power (dBm)	Excluded Cells	Peak Field (V/m)	Peak Field converted to (dB V/m)	FCC Limit (dB V/m)	Rating
GSM 1900MHz	Fixed	<b>512</b>	<b>29.96</b>	<b>1,4,7</b>	<b>60.5</b>	<b>35.64</b>	<b>38.5</b>	<b>M3</b>
		661	29.97	1,4,7	59.3	35.46	38.5	M3
		810	29.95	1,4,7	60.1	35.58	38.5	M3

**Table 7: HAC H-Field measurement results for the portable cellular telephone  
FCC ID IHDT56EU3 at highest possible output power**

Frequency Band (MHz)	Antenna position	Channel Setting	Conducted Output Power (dBm)	Excluded Cells	Peak Field (A/m)	Peak Field converted to (dB A/m)	FCC Limit (dB A/m)	Rating
GSM 1900MHz	Fixed	512	29.96	4,7,8	0.142	-16.95	-16.9	M4
		661	29.97	4,7,8	0.15	-16.48	-11.9	M3
		<b>810</b>	<b>29.95</b>	<b>7,8,9</b>	<b>0.157</b>	<b>-16.08</b>	<b>-11.9</b>	<b>M3</b>

**Appendix 1**

**HAC distribution plots for the system accuracy verification**

Date/Time: 8/15/2005

## Test Laboratory: Motorola

### E-Field; CW 1880 MHz; -11.6% GOOD

#### DUT: Planar Dipole 1880 MHz;

Procedure Notes: 1880 MHz HAC Validation / Dipole Sn# P1880-003; Input Power = 100mW;

Communication System: CW mode; Frequency: 1880 MHz; Duty Cycle: 1:1

Medium: Air; Medium parameters used:  $\sigma = 0$  mho/m,  $\epsilon_r = 1$ ;  $\rho = 0$  kg/m<sup>3</sup>

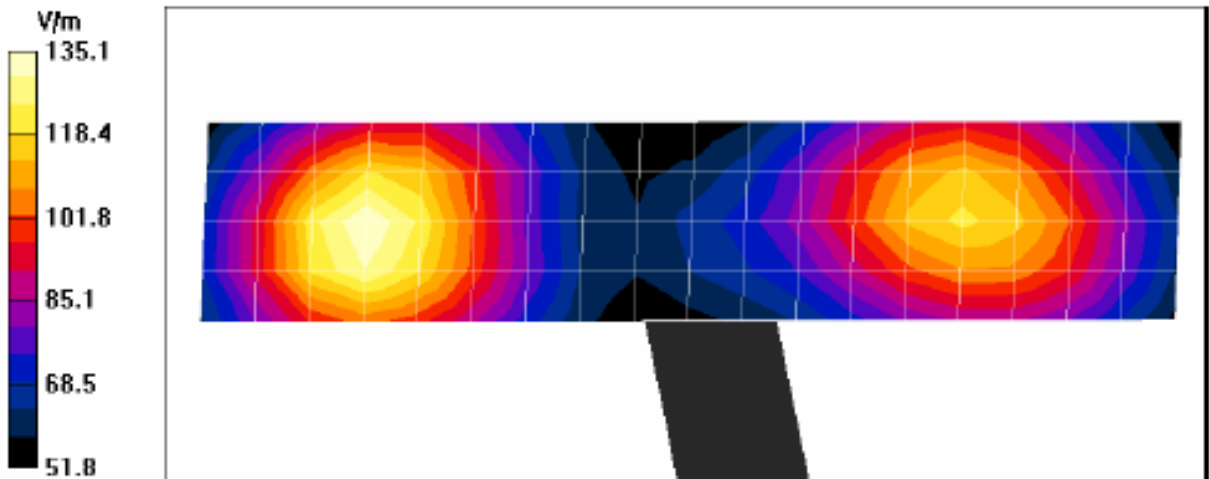
DASY4 Configuration:

- Probe: ER3DV6R - SN2247; ConvF(1, 1, 1); Calibrated: 7/20/2005
- Sensor-Surface: 0mm (Fix Surface)
- Electronics: DAE3 Sn378; Calibrated: 7/8/2005
- Phantom: HAC Phantom, Rev.3 (4-Aug-05); Type: Free Space; Serial: n/a;
- Measurement SW: DASY4, V4.5 Build 19; Postprocessing SW: SEMCAD, V1.8 Build 147

#### HAC Main Procedure/E-Field PLANAR: 1880 HAC Validation (41x181x1):

Measurement grid: dx=5mm, dy=5mm

Maximum value of E\_tot (interpolated) = 135.8 V/m



## Test Laboratory: Motorola

### H-Field; CW 1880 MHz; -9.6% GOOD

#### DUT: Planar Dipole 1880 MHz;

Procedure Notes: 1880 MHz HAC Validation / Dipole Sn# P1880-003; Input Power = 100 mW;

Communication System: CW mode; Frequency: 1880 MHz; Duty Cycle: 1:1

Medium: Air; Medium parameters used:  $\sigma = 0$  mho/m,  $\epsilon_r = 1$ ;  $\rho = 0$  kg/m<sup>3</sup>

DASY4 Configuration:

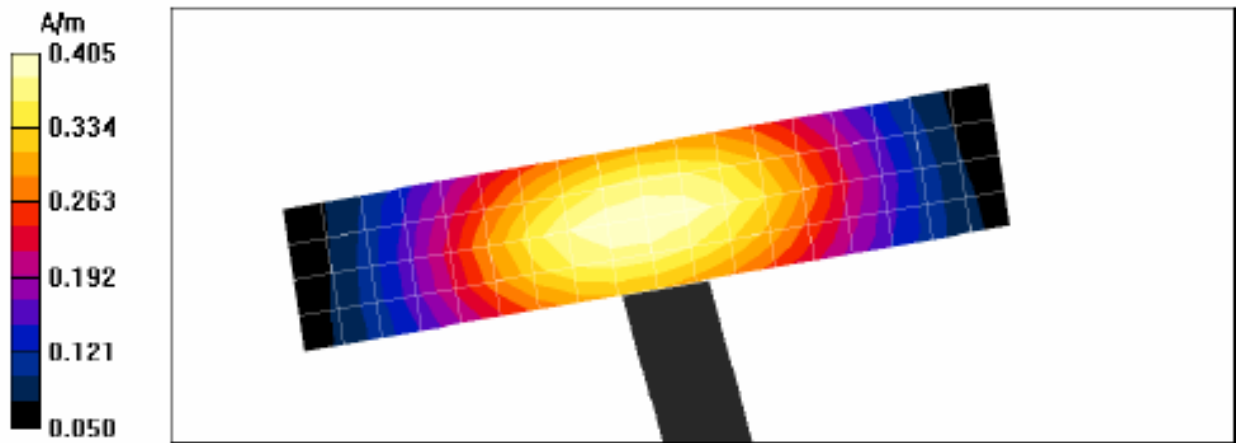
- Probe: H3DV6 - SN6074; ; Calibrated: 7/20/2005
- Sensor-Surface: 0mm (Fix Surface)
- Electronics: DAE3 Sn378; Calibrated: 7/8/2005
- Phantom: HAC Phantom, Rev.3 (4-Aug-05); Type: Free Space; Serial: n/a;
- Measurement SW: DASY4, V4.5 Build 19; Postprocessing SW: SEMCAD, V1.8 Build 147

#### HAC Main Procedure/H-Field PLANAR: 1880 HAC Validation (41x181x1):

Measurement grid: dx=5mm, dy=5mm

Maximum value of H\_tot (interpolated) = 0.405 A/m

Page H-Field; CW 1880 MHz; -9.5% GOOD e 1 of 1



**Appendix 2**

**HAC distribution plots for E-Field and H-Field**

Date/Time: 8/19/2005

# Test Laboratory: Motorola

**Serial: LRZ0420029**

Procedure Notes: Pwr Step: 00 (OTA); Antenna Position: INTERNAL; Accessory Model #: N/A; Communication System: GSM 1900; Frequency: 1850.2 MHz;

Communication System Channel Number: 512; Duty Cycle\*: 1:9.33

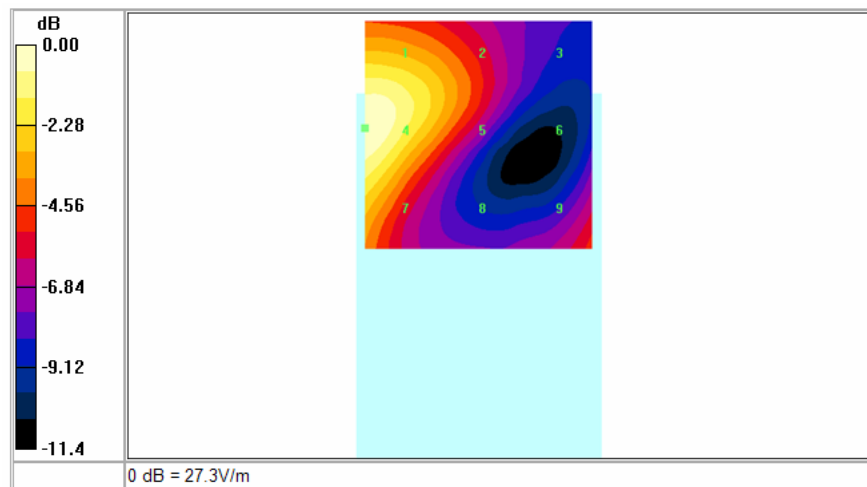
Medium: Air; Medium parameters used:  $\sigma = 0$  mho/m,  $\epsilon_r = 1$ ;  $\rho = 0$  kg/m<sup>3</sup>

DASY4 Configuration:

- Probe: ER3DV6R - SN2247; ConvF(1, 1, 1); Calibrated: 7/20/2005
- Sensor-Surface: (Fix Surface)
- Electronics: DAE3 Sn378; Calibrated: 7/8/2005
- Phantom: HAC Phantom, Rev.3 (4-Aug-05); Type: Free Space; Serial: n/a;
- Measurement SW: DASY4, V4.5 Build 19; Postprocessing SW: SEMCAD, V1.8 Build 147

Power Drift: -0.0375 dB

E in V/m (Time averaged)			E in V/m (Slot averaged)		
Grid 1 <b>25.0</b>	Grid 2 <b>19.8</b>	Grid 3 <b>11.8</b>	Grid 1 <b>76.4</b>	Grid 2 <b>60.4</b>	Grid 3 <b>36.0</b>
Grid 4 <b>27.3</b>	Grid 5 <b>19.8</b>	Grid 6 <b>11.6</b>	Grid 4 <b>83.3</b>	Grid 5 <b>60.5</b>	Grid 6 <b>35.5</b>
Grid 7 <b>23.5</b>	Grid 8 <b>12.9</b>	Grid 9 <b>15.6</b>	Grid 7 <b>71.7</b>	Grid 8 <b>39.5</b>	Grid 9 <b>47.7</b>



\*NOTE: Duty cycle on page 3 is the standard GSM transmitter ratio of 1:8. The phone plots in Appendix 2 use the term “Duty Cycle” as well due to terminology of the software, but this actually refers to the Crest Factor which accounts for probe modulation response. Thus the ratio is 1:9.33 to account for PMF in the system. Actual GSM duty cycle is more appropriately termed on page 3, whereas Appendix 2 references to Duty Cycle would be more appropriately termed “Crest Factor.”

Date/Time: 8/19/2005

# Test Laboratory: Motorola

**Serial: LRZ0420029**

Procedure Notes: Pwr Step: 00 (OTA); Antenna Position: INTERNAL; Accessory Model #: N/A;

Communication System: GSM 1900; Frequency: 1909.8 MHz; Communication System Channel Number: 810; Duty Cycle\*: 1:8.74

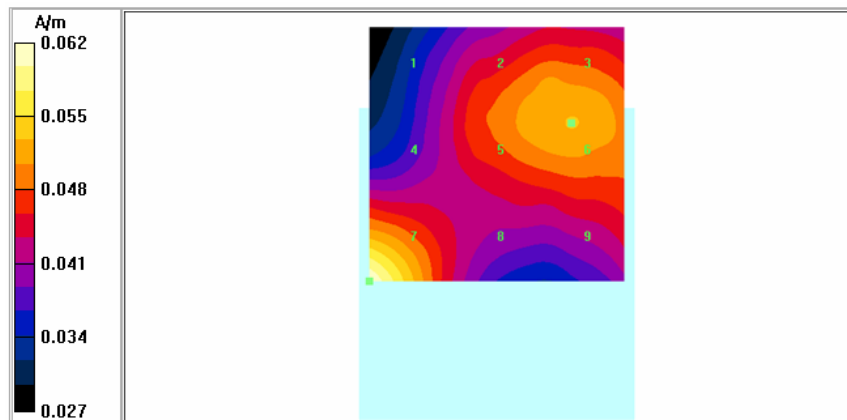
Medium: Air; Medium parameters used:  $\sigma = 0$  mho/m,  $\epsilon_r = 1$ ;  $\rho = 0$  kg/m<sup>3</sup>

DASY4 Configuration:

- Probe: H3DV6 - SN6074; ; Calibrated: 7/20/2005
- Sensor-Surface: (Fix Surface)
- Electronics: DAE3 Sn378; Calibrated: 7/8/2005
- Phantom: HAC Phantom, Rev.3 (4-Aug-05); Type: Free Space; Serial: n/a;
- Measurement SW: DASY4, V4.5 Build 19; Postprocessing SW: SEMCAD, V1.8 Build 147

Power Drift: 0.0827 dB

H in A/m (Time averaged)			H in A/m (Slot averaged)		
Grid 1 <b>0.043</b>	Grid 2 <b>0.052</b>	Grid 3 <b>0.053</b>	Grid 1 <b>0.127</b>	Grid 2 <b>0.153</b>	Grid 3 <b>0.156</b>
Grid 4 <b>0.043</b>	Grid 5 <b>0.052</b>	Grid 6 <b>0.053</b>	Grid 4 <b>0.128</b>	Grid 5 <b>0.154</b>	Grid 6 <b>0.157</b>
Grid 7 <b>0.062</b>	Grid 8 <b>0.045</b>	Grid 9 <b>0.047</b>	Grid 7 <b>0.185</b>	Grid 8 <b>0.132</b>	Grid 9 <b>0.140</b>



\*NOTE: Duty cycle on page 3 is the standard GSM transmitter ratio of 1:8. The phone plots in Appendix 2 use the term “Duty Cycle” as well due to terminology of the software, but this actually refers to the Crest Factor which accounts for probe modulation response. Thus the ratio is 1:9.33 to account for PMF in the system. Actual GSM duty cycle is more appropriately termed on page 3, whereas Appendix 2 references to Duty Cycle would be more appropriately termed “Crest Factor.”

**Appendix 3**

**Measurement Uncertainty Budget**

### A3.1 Motorola Uncertainty Budget for RF HAC Testing

**TABLE A3.1: Motorola Uncertainty Budget**

UNCERTAINTY DESCRIPTION	Uncertainty Value (+/- %)	Prob. Dist.	Div.	(ci) E	(ci) H	Std. Unc. E	Std. Unc. H	Source
<b>MEASUREMENT SYSTEM</b>								
Probe Calibration	5.1%	N	1.0000	1	1	5.1%	5.1%	SPEAG HAC Extension Application Note (April 2005)
Axial Isotropy	7.8%	R	1.7321	1	0.786	4.5%	3.5%	Motorola Evaluation
Sensor Displacement	16.5%	R	1.7321	1	0.145	9.5%	1.4%	SPEAG HAC Extension Application Note (April 2005)
Boundary Effects	2.4%	R	1.7321	1	1	1.4%	1.4%	SPEAG HAC Extension Application Note (April 2005)
Linearity	4.7%	R	1.7321	1	1	2.7%	2.7%	SPEAG HAC Extension Application Note (April 2005)
Scaling to Peak Envelope Power	2.0%	R	1.7321	1	1	1.2%	1.2%	SPEAG HAC Extension Application Note (April 2005)
System Detection Limit	1.0%	R	1.7321	1	1	0.6%	0.6%	SPEAG HAC Extension Application Note (April 2005)
Readout Electronics	0.3%	N	1.0000	1	1	0.3%	0.3%	SPEAG HAC Extension Application Note (April 2005)
Response Time	0.8%	R	1.7321	1	1	0.5%	0.5%	SPEAG HAC Extension Application Note (April 2005)
Integration Time	2.6%	R	1.7321	1	1	1.5%	1.5%	SPEAG HAC Extension Application Note (April 2005)
RF Reflections	5.6%	R	1.7321	1	1	3.2%	3.2%	Motorola Evaluation
Probe Positioner	1.2%	R	1.7321	1	0.67	0.7%	0.5%	SPEAG HAC Extension Application Note (April 2005)
Probe Positioning	4.7%	R	1.7321	1	0.67	2.7%	1.8%	SPEAG HAC Extension Application Note (April 2005)
Extrap. & Interpolation	1.0%	R	1.7321	1	1	0.6%	0.6%	SPEAG HAC Extension Application Note (April 2005)
<b>TEST SAMPLE RELATED</b>								
Total Device Positioning	3.2%	R	1.7321	1	1.306	1.8%	2.4%	Motorola Evaluation
Device Holder & Phantom	2.4%	R	1.7321	1	1	1.4%	1.4%	SPEAG HAC Extension Application Note (April 2005)
Power Drift	5.0%	R	1.7321	1	1	2.9%	2.9%	SPEAG HAC Extension Application Note (April 2005)
<b>PHANTOM AND SETUP RELATED</b>								
Phantom Thickness	0.0%	R	1.7321	1	0.67	0.0%	0.0%	SPEAG HAC Extension Application Note (April 2005)
<b>Combined Std.Uncertainty</b>						<b>13.5%</b>	<b>9.2%</b>	
<b>Expanded Std. Uncertainty on Power</b>						<b>27.0%</b>	<b>18.3%</b>	

### A3.2 Probe Rotation Contributions to Isotropy Error

Probe rotation data was taken “for special focus on spherical isotropicity in measurement uncertainty and perturbation of EM fields.” This data was taken at the interpolated maximum and directly accounted for in the uncertainty budget as “Axial Isotropy.” Thirteen mobile devices were used to determine the probe isotropy uncertainty factors in section A4.1. Based on the resulting 82 E-Field probe rotations and 82 H-Field probe rotations, the upper 95% confidence interval value was calculated for each. These values represent a conservative assessment of the effect of the probe isotropy and have been appropriately included in the respective E- and H-uncertainty budgets.

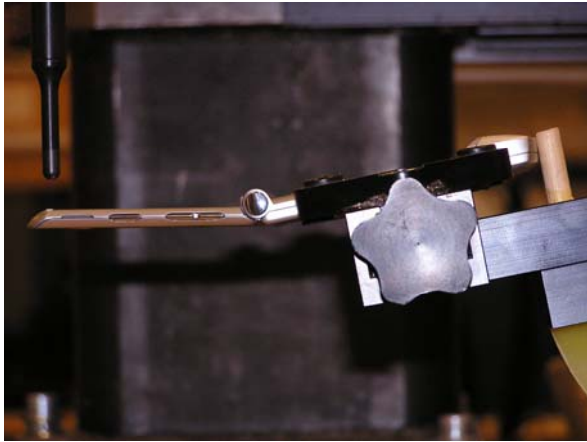
**TABLE A3.2: Probe Rotation Data Summary**

	AVE	ST.DEV	Sample Size (n)	2σ	(ci)	Standard Uncertainty
E-field	4.4%	1.7%	82	7.8%	1	4.5%
H-field	3.8%	1.2%	82	6.1%	0.786	3.5%

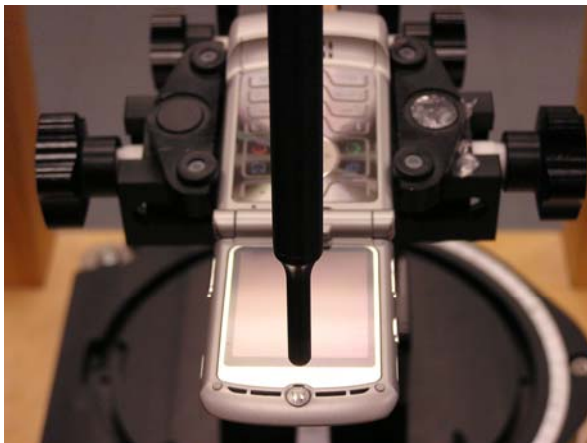
Isotropy error measurements were taken for 13 products across the respective frequency bands. The +2σ values of all measurements was used as a worst case value for the uncertainty budget. Any significant differences between bands was also evaluated.

**Appendix 4**

**Pictures of Test Setup**



**Figure A4-1. Views from the side**



**Figure A4-2. Views from above**

**Appendix 5**

**Probe Calibration Certificates**



Accredited by the Swiss Federal Office of Metrology and Accreditation  
**The Swiss Accreditation Service is one of the signatories to the EA  
Multilateral Agreement for the recognition of calibration certificates**

Accreditation No.: **SCS 108**

Client **Motorola MDb**

Certificate No: **ER3-2247\_Jul05**

## CALIBRATION CERTIFICATE

Object **ER3DV6R - SN:2247**

Calibration procedure(s) **QA CAL-02.v4  
Calibration procedure for E-field probes optimized for close near field  
evaluations in air**

Calibration date: **July 20, 2005**

Condition of the calibrated item **In Tolerance**

This calibration certificate documents the traceability to national standards, which realize the physical units of measurements (SI).  
The measurements and the uncertainties with confidence probability are given on the following pages and are part of the certificate.

All calibrations have been conducted in the closed laboratory facility: environment temperature (22 ± 3)°C and humidity < 70%.

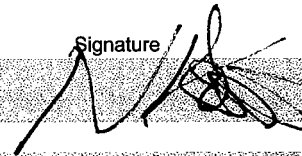
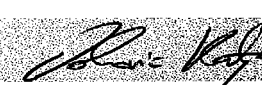
Calibration Equipment used (M&TE critical for calibration)

Primary Standards	ID #	Cal Date (Calibrated by, Certificate No.)	Scheduled Calibration
Power meter E4419B	GB41293874	3-May-05 (METAS, No. 251-00466)	May-06
Power sensor E4412A	MY41495277	3-May-05 (METAS, No. 251-00466)	May-06
Power sensor E4412A	MY41498087	3-May-05 (METAS, No. 251-00466)	May-06
Reference 3 dB Attenuator	SN: S5054 (3c)	10-Aug-04 (METAS, No. 251-00403)	Aug-05
Reference 20 dB Attenuator	SN: S5086 (20b)	3-May-05 (METAS, No. 251-00467)	May-06
Reference 30 dB Attenuator	SN: S5129 (30b)	10-Aug-04 (METAS, No. 251-00404)	Aug-05
Reference Probe ER3DV6	SN: 2328	6-Oct-04 (SPEAG, No. ER3-2328_Oct04)	Oct-05
DAE4	SN: 907	21-Jun-05 (SPEAG, No. DAE4-907_Jun05)	Jun-06

Secondary Standards	ID #	Check Date (in house)	Scheduled Check
RF generator HP 8648C	US3642U01700	4-Aug-99 (SPEAG, in house check Dec-03)	In house check: Dec-05
Network Analyzer HP 8753E	US37390585	18-Oct-01 (SPEAG, in house check Nov-04)	In house check: Nov 05

Calibrated by: **Nico Vetterli** Laboratory Technician

Approved by: **Katja Pokovic** Technical Manager

Signature  
  


Issued: July 20, 2005

This calibration certificate shall not be reproduced except in full without written approval of the laboratory.



Accredited by the Swiss Federal Office of Metrology and Accreditation  
The Swiss Accreditation Service is one of the signatories to the EA  
Multilateral Agreement for the recognition of calibration certificates

Accreditation No.: **SCS 108**

**Glossary:**

NORM <sub>x,y,z</sub>	sensitivity in free space
DCP	diode compression point
Polarization $\varphi$	$\varphi$ rotation around probe axis
Polarization $\vartheta$	$\vartheta$ rotation around an axis that is in the plane normal to probe axis (at measurement center), i.e., $\vartheta = 0$ is normal to probe axis
Connector Angle	information used in DASY system to align probe sensor X to the robot coordinate system

**Calibration is Performed According to the Following Standards:**

- a) IEEE Std 1309-1996, "IEEE Standard for calibration of electromagnetic field sensors and probes, excluding antennas, from 9 kHz to 40 GHz", 1996.

**Methods Applied and Interpretation of Parameters:**

- *NORM<sub>x,y,z</sub>*: Assessed for E-field polarization  $\vartheta = 0$  for XY sensors and  $\vartheta = 90$  for Z sensor ( $f \leq 900$  MHz in TEM-cell;  $f > 1800$  MHz: R22 waveguide).
- *NORM(f)<sub>x,y,z</sub>* = *NORM<sub>x,y,z</sub>* \* *frequency\_response* (see Frequency Response Chart).
- *DCP<sub>x,y,z</sub>*: DCP are numerical linearization parameters assessed based on the data of power sweep (no uncertainty required). DCP does not depend on frequency.
- *Spherical isotropy (3D deviation from isotropy)*: in a locally homogeneous field realized using an open waveguide setup.
- *Sensor Offset*: The sensor offset corresponds to the offset of virtual measurement center from the probe tip (on probe axis). No tolerance required.
- *Connector Angle*: The angle is assessed using the information gained by determining the *NORM<sub>x</sub>* (no uncertainty required).

# Probe ER3DV6R

## SN:2247

Manufactured:	February 1, 2000
Last calibrated:	March 6, 2000
Recalibrated:	July 20, 2005

Calibrated for DASY Systems

(Note: non-compatible with DASY2 system!)

**DASY - Parameters of Probe: ER3DV6R SN:2247**Sensitivity in Free Space [ $\mu\text{V}/(\text{V}/\text{m})^2$ ]Diode Compression<sup>A</sup>NormX      **1.76 ± 10.1 % (k=2)**DCP X      **97 mV**NormY      **1.51 ± 10.1 % (k=2)**DCP Y      **97 mV**NormZ      **1.47 ± 10.1 % (k=2)**DCP Z      **96 mV**

Frequency Correction

X                      **0.0**Y                      **0.0**Z                      **0.0**

Sensor Offset

(Probe Tip to Sensor Center)

X                      **2.5 mm**Y                      **2.5 mm**Z                      **2.5 mm**

Connector Angle

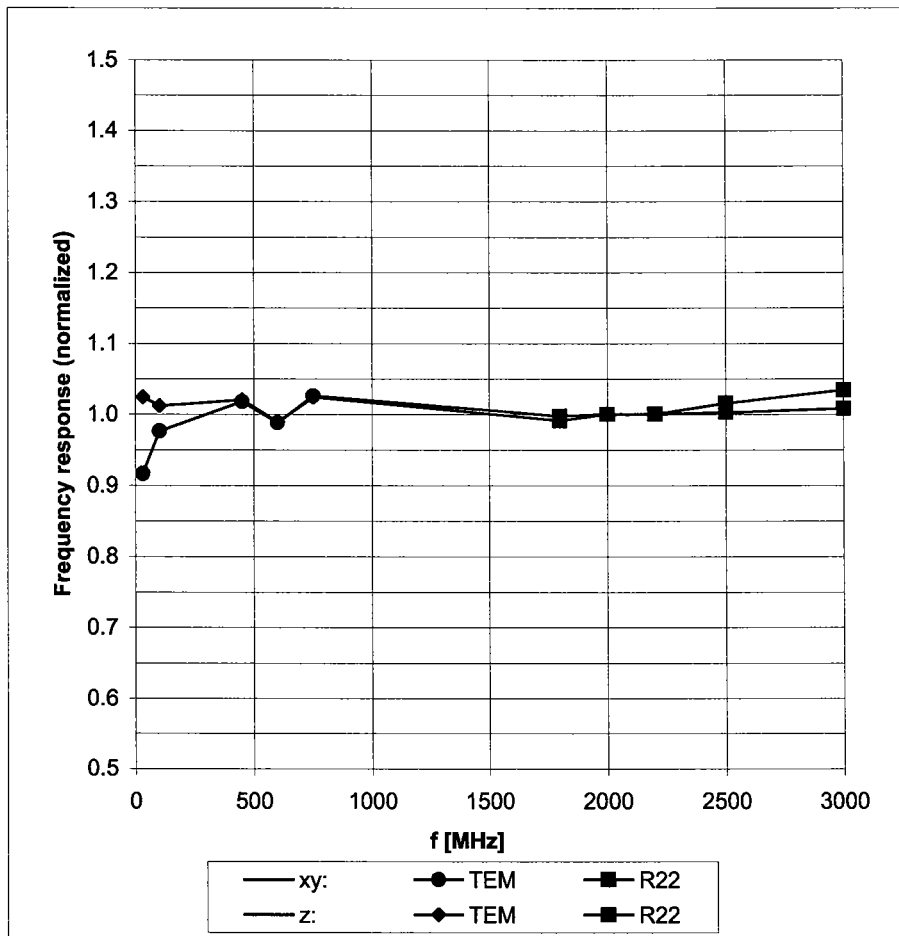
**214 °**

**The reported uncertainty of measurement is stated as the standard uncertainty of measurement multiplied by the coverage factor k=2, which for a normal distribution corresponds to a coverage probability of approximately 95%.**

<sup>A</sup> numerical linearization parameter: uncertainty not required

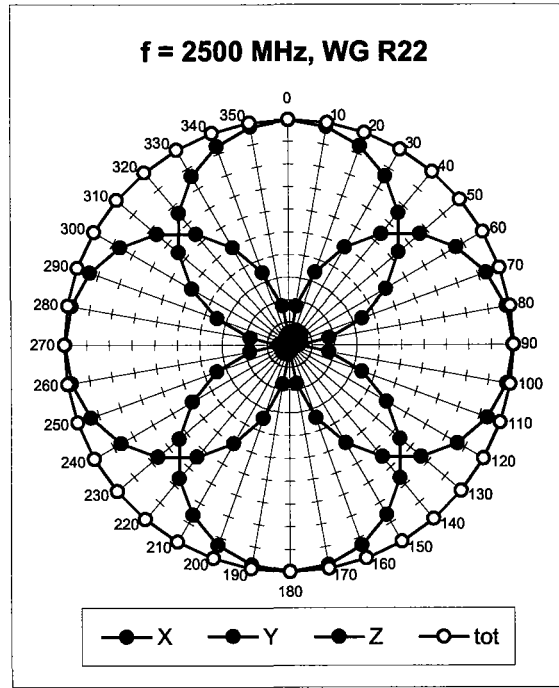
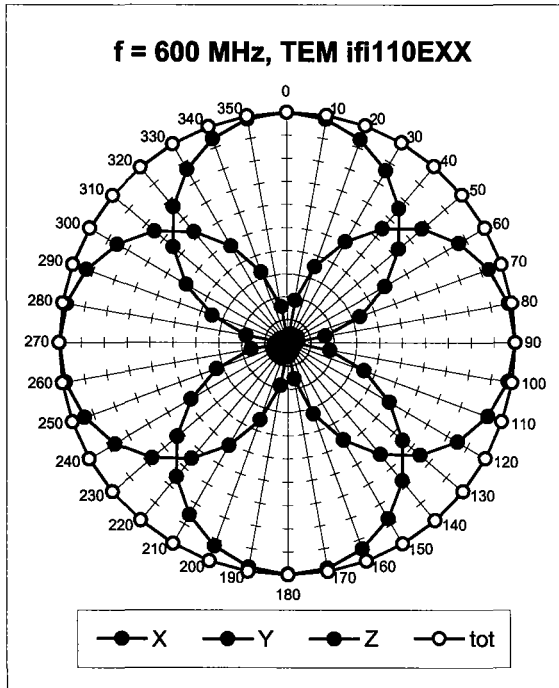
# Frequency Response of E-Field

(TEM-Cell:ifi110 EXX, Waveguide R22)

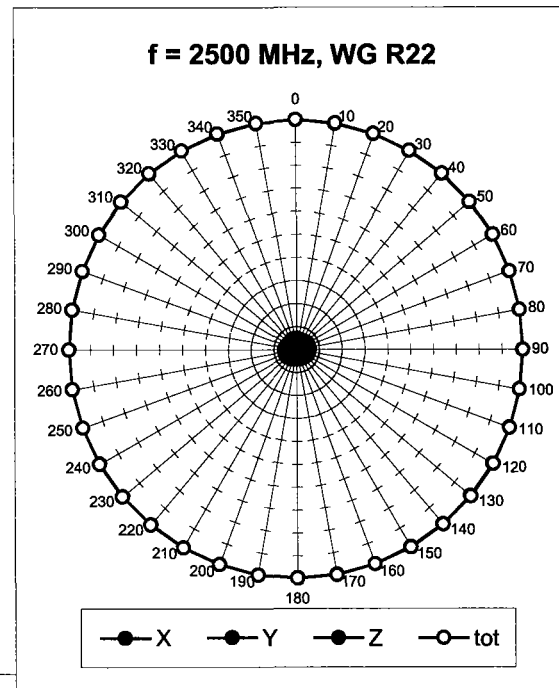
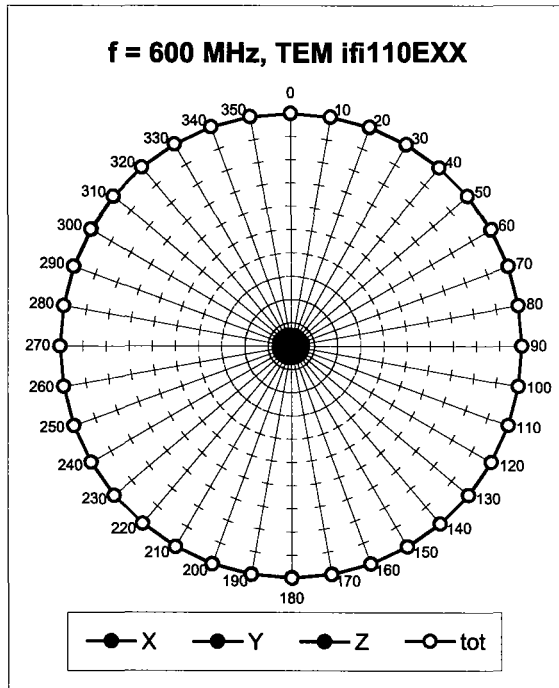


Uncertainty of Frequency Response of E-field:  $\pm 6.3\%$  ( $k=2$ )

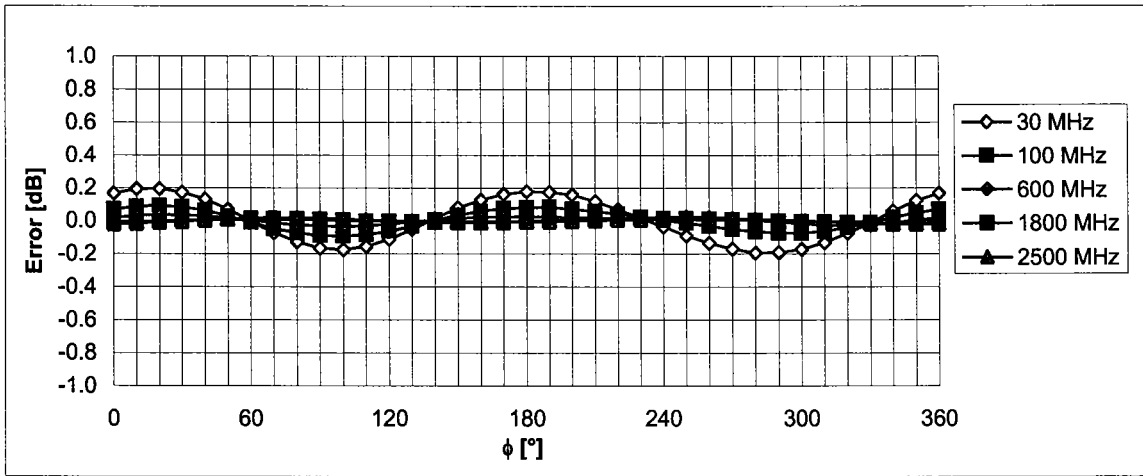
### Receiving Pattern ( $\phi$ ), $\vartheta = 0^\circ$



### Receiving Pattern ( $\phi$ ), $\vartheta = 90^\circ$

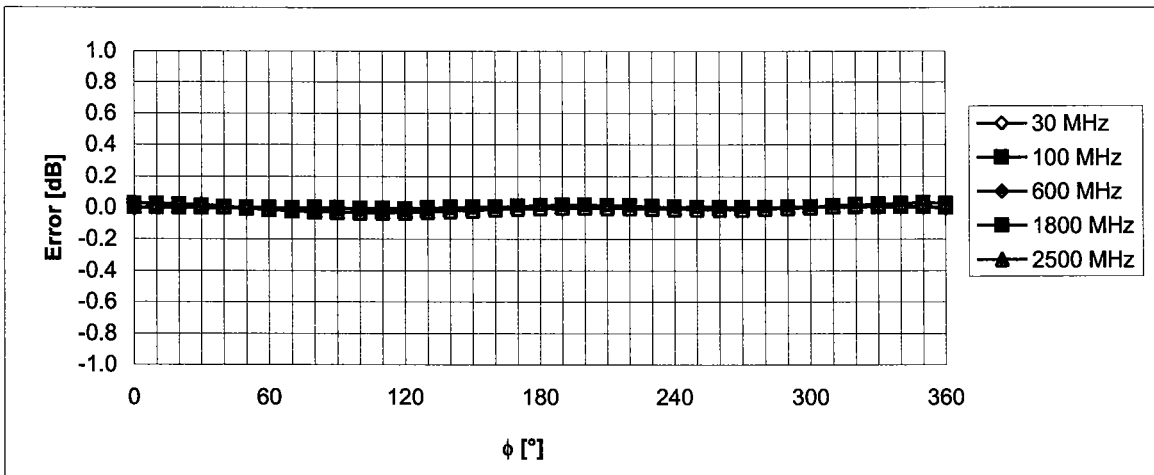


### Receiving Pattern ( $\phi$ ), $\vartheta = 0^\circ$



Uncertainty of Axial Isotropy Assessment:  $\pm 0.5\%$  ( $k=2$ )

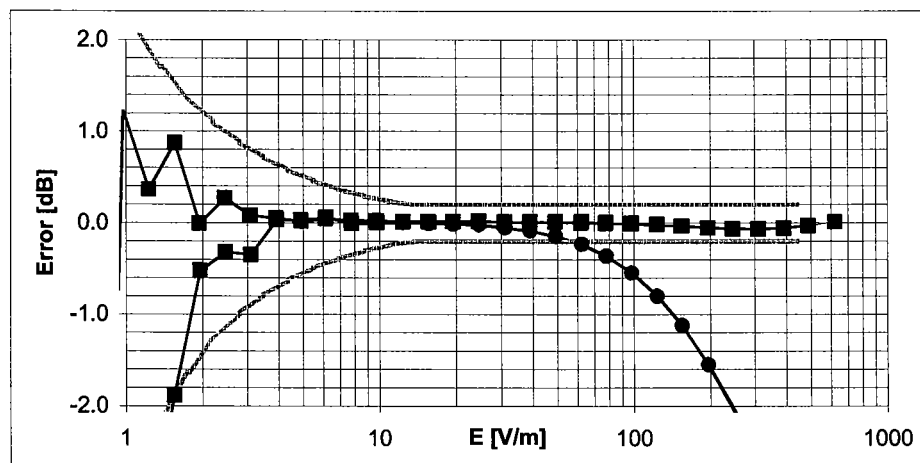
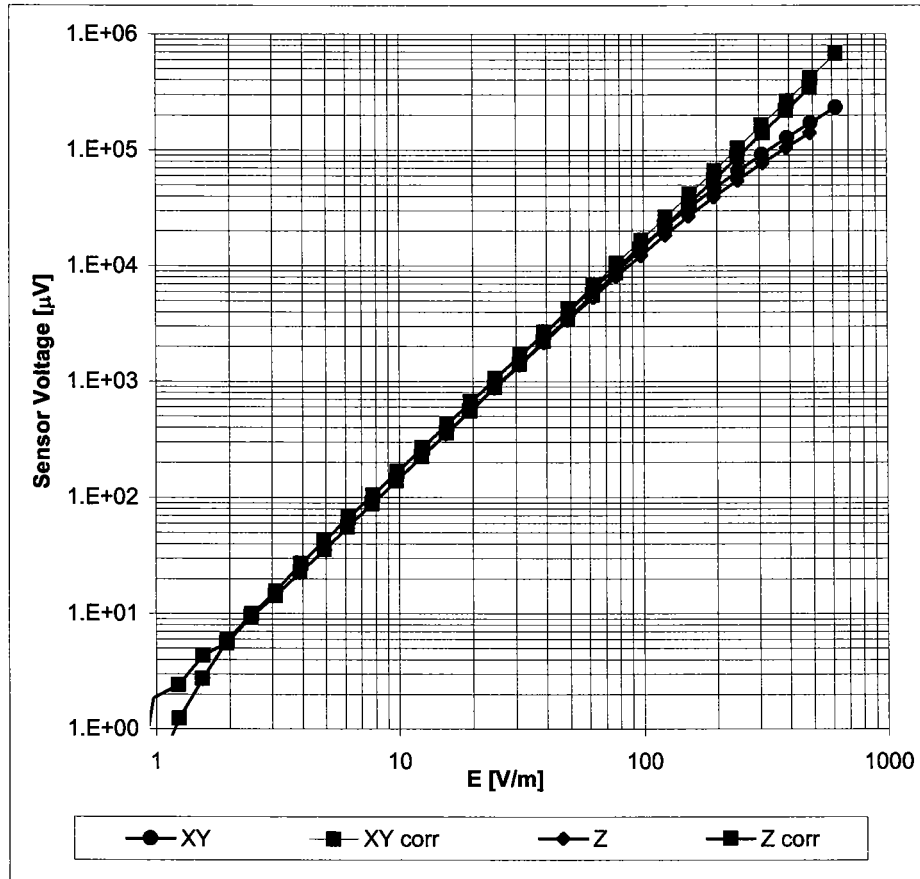
### Receiving Pattern ( $\phi$ ), $\vartheta = 90^\circ$



Uncertainty of Axial Isotropy Assessment:  $\pm 0.5\%$  ( $k=2$ )

## Dynamic Range f(E-field)

(Waveguide R22, f = 1800 MHz)



**Uncertainty of Linearity Assessment:  $\pm 0.6\%$  ( $k=2$ )**



Accredited by the Swiss Federal Office of Metrology and Accreditation  
The Swiss Accreditation Service is one of the signatories to the EA  
Multilateral Agreement for the recognition of calibration certificates

Accreditation No.: **SCS 108**

Client **Motorola MDb**

Certificate No: **H3-6074\_Jul05**

## CALIBRATION CERTIFICATE

Object **H3DV6 - SN:6074**

Calibration procedure(s) **QA CAL-03.v4  
Calibration procedure for H-field probes optimized for close near field  
evaluations in air**

Calibration date: **July 20, 2005**

Condition of the calibrated item **In Tolerance**

This calibration certificate documents the traceability to national standards, which realize the physical units of measurements (SI).  
The measurements and the uncertainties with confidence probability are given on the following pages and are part of the certificate.

All calibrations have been conducted in the closed laboratory facility: environment temperature ( $22 \pm 3$ )°C and humidity < 70%.

Calibration Equipment used (M&TE critical for calibration)

Primary Standards	ID #	Cal Date (Calibrated by, Certificate No.)	Scheduled Calibration
Power meter E4419B	GB41293874	3-May-05 (METAS, No. 251-00466)	May-06
Power sensor E4412A	MY41495277	3-May-05 (METAS, No. 251-00466)	May-06
Power sensor E4412A	MY41498087	3-May-05 (METAS, No. 251-00466)	May-06
Reference 3 dB Attenuator	SN: S5054 (3c)	10-Aug-04 (METAS, No. 251-00403)	Aug-05
Reference 20 dB Attenuator	SN: S5086 (20b)	3-May-05 (METAS, No. 251-00467)	May-06
Reference 30 dB Attenuator	SN: S5129 (30b)	10-Aug-04 (METAS, No. 251-00404)	Aug-05
Reference Probe H3DV6	SN: 6182	6-Oct-04 (SPEAG, No. H3-6182_Oct04)	Oct-05
DAE4	SN: 907	21-Jun-05 (SPEAG, No. DAE4-907_Jun05)	Jun-06

Secondary Standards	ID #	Check Date (in house)	Scheduled Check
RF generator HP 8648C	US3642U01700	4-Aug-99 (SPEAG, in house check Dec-03)	In house check: Dec-05
Network Analyzer HP 8753E	US37390585	18-Oct-01 (SPEAG, in house check Nov-04)	In house check: Nov 05

Calibrated by: **Nico Vetterli**      Function: **Laboratory Technician**

Signature

Approved by: **Katja Pokovic**      Technical Manager

Issued: July 20, 2005

This calibration certificate shall not be reproduced except in full without written approval of the laboratory.



Accredited by the Swiss Federal Office of Metrology and Accreditation  
The Swiss Accreditation Service is one of the signatories to the EA  
Multilateral Agreement for the recognition of calibration certificates

Accreditation No.: **SCS 108**

**Glossary:**

NORM <sub>x,y,z</sub>	sensitivity in free space
DCP	diode compression point
Polarization $\varphi$	$\varphi$ rotation around probe axis
Polarization $\vartheta$	$\vartheta$ rotation around an axis that is in the plane normal to probe axis (at measurement center), i.e., $\vartheta = 0$ is normal to probe axis
Connector Angle	information used in DASY system to align probe sensor X to the robot coordinate system

**Calibration is Performed According to the Following Standards:**

- a) IEEE Std 1309-1996, "IEEE Standard for calibration of electromagnetic field sensors and probes, excluding antennas, from 9 kHz to 40 GHz", 1996.

**Methods Applied and Interpretation of Parameters:**

- $X, Y, Z_{a0a1a2}$ : Assessed for E-field polarization  $\vartheta = 90$  for XY sensors and  $\vartheta = 0$  for Z sensor ( $f \leq 900$  MHz in TEM-cell;  $f > 1800$  MHz: R22 waveguide).
- $X, Y, Z(f)_{a0a1a2} = X, Y, Z_{a0a1a2} \cdot \text{frequency\_response}$  (see Frequency Response Chart).
- $DCP_{x,y,z}$ : DCP are numerical linearization parameters assessed based on the data of power sweep (no uncertainty required). DCP does not depend on frequency.
- *Spherical isotropy (3D deviation from isotropy)*: in a locally homogeneous field realized using an open waveguide setup.
- *Sensor Offset*: The sensor offset corresponds to the offset of virtual measurement center from the probe tip (on probe axis). No tolerance required.
- *Connector Angle*: The angle is assessed using the information gained by determining the  $X_{a0a1a2}$  (no uncertainty required).

# Probe H3DV6

## SN:6074

Manufactured:	October 2, 2000
Last calibrated:	September 18, 2003
Recalibrated:	July 20, 2005

Calibrated for DASY Systems

(Note: non-compatible with DASY2 system!)

## DASY - Parameters of Probe: H3DV6 SN:6074

Sensitivity in Free Space [A/m /  $\sqrt{\mu\text{V}}$ ]

	a0	a1	a2
X	2.732E-03	-1.128E-4	2.808E-5 ± 5.1 % (k=2)
Y	2.654E-03	-8.281E-5	-6.750E-5 ± 5.1 % (k=2)
Z	3.180E-03	-2.987E-4	-2.131E-5 ± 5.1 % (k=2)

Diode Compression<sup>1</sup>

DCP X	86 mV
DCP Y	86 mV
DCP Z	86 mV

Sensor Offset (Probe Tip to Sensor Center)

X	3.0 mm
Y	3.0 mm
Z	3.0 mm

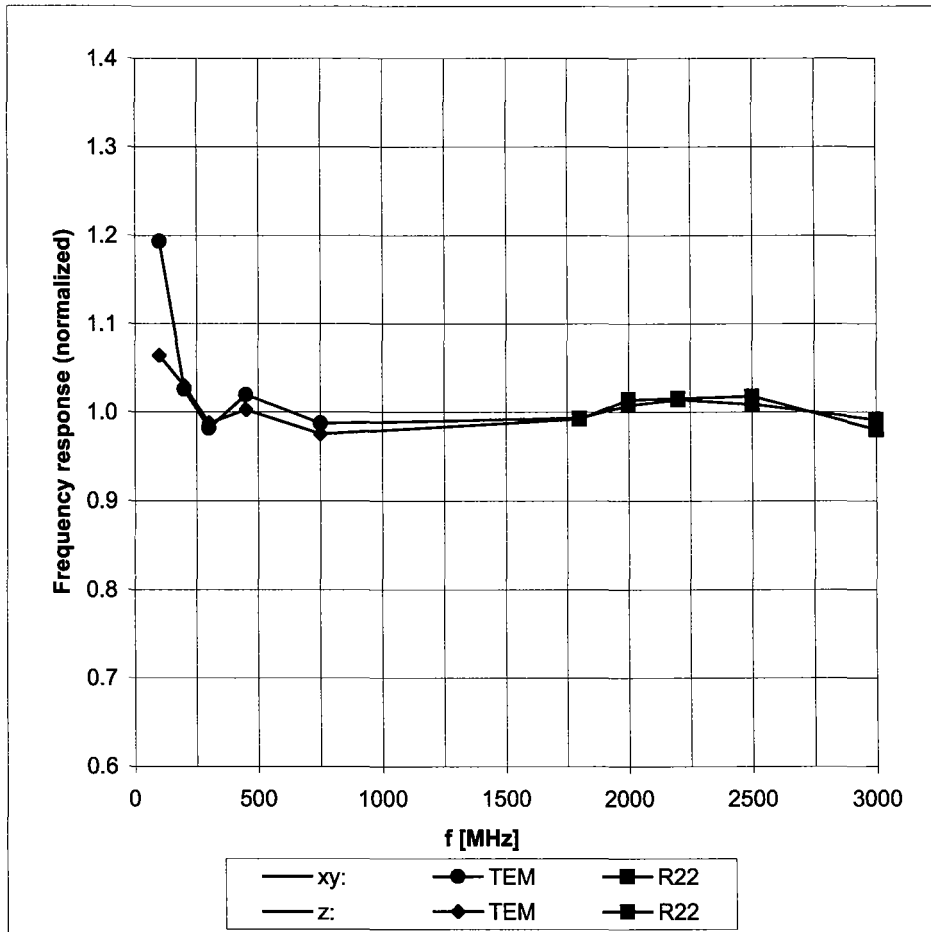
Connector Angle 190 °

The reported uncertainty of measurement is stated as the standard uncertainty of measurement multiplied by the coverage factor k=2, which for a normal distribution corresponds to a coverage probability of approximately 95%.

<sup>1</sup> numerical linearization parameter: uncertainty not required

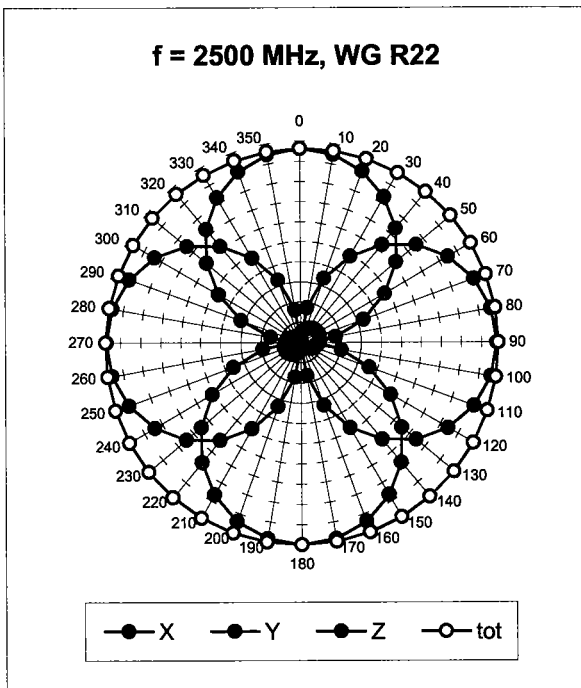
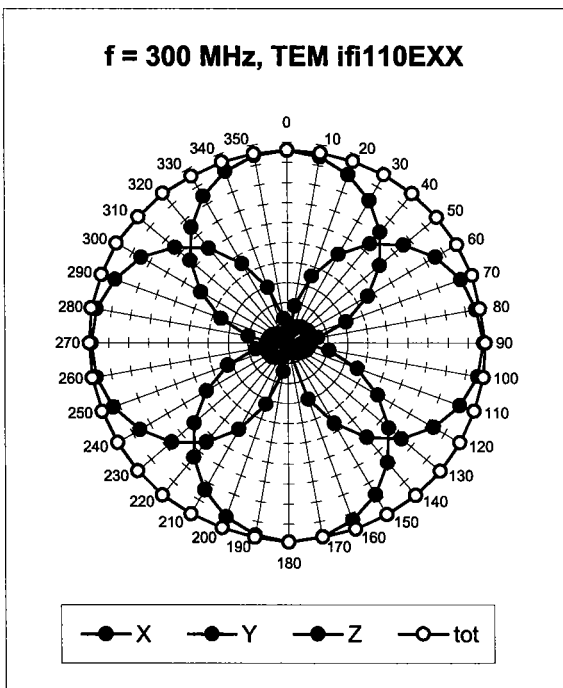
# Frequency Response of H-Field

(TEM-Cell:ifi110, Waveguide R22)

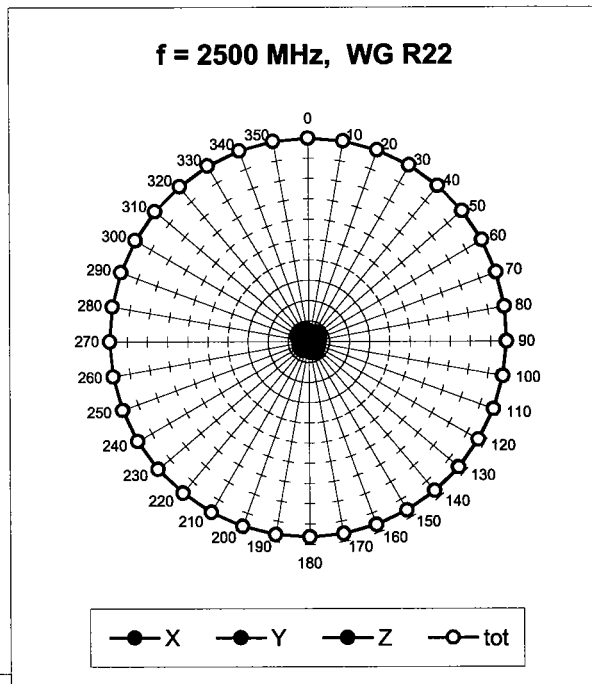
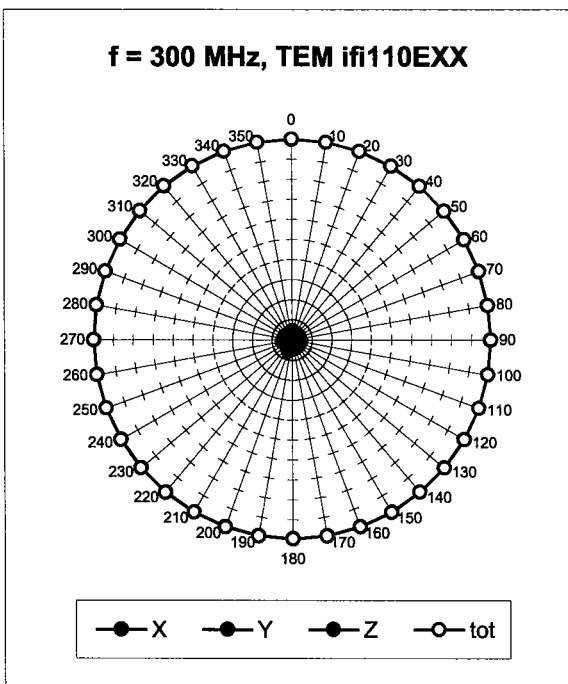


Uncertainty of Frequency Response of E-field:  $\pm 6.3\%$  (k=2)

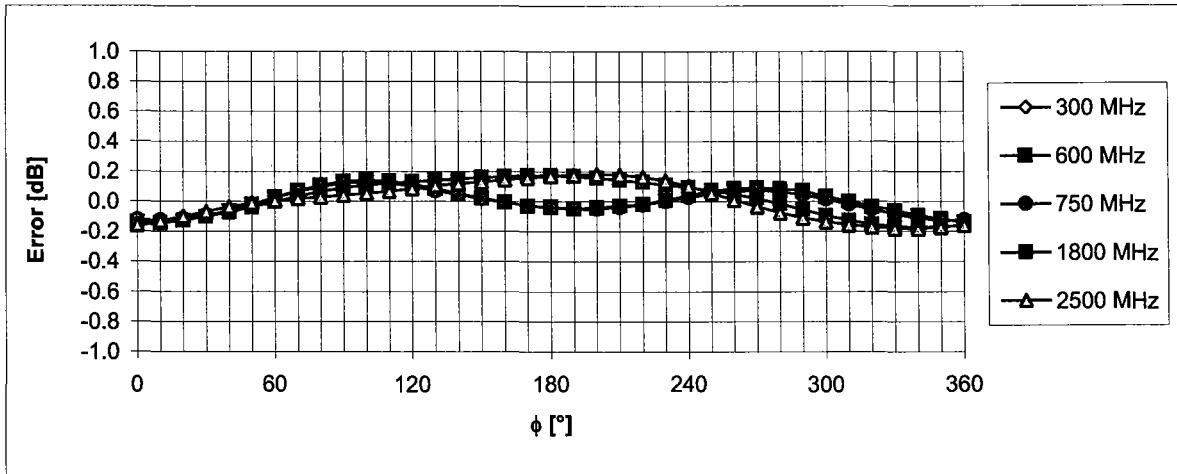
### Receiving Pattern ( $\phi$ ), $\vartheta = 90^\circ$



### Receiving Pattern ( $\phi$ ), $\vartheta = 0^\circ$

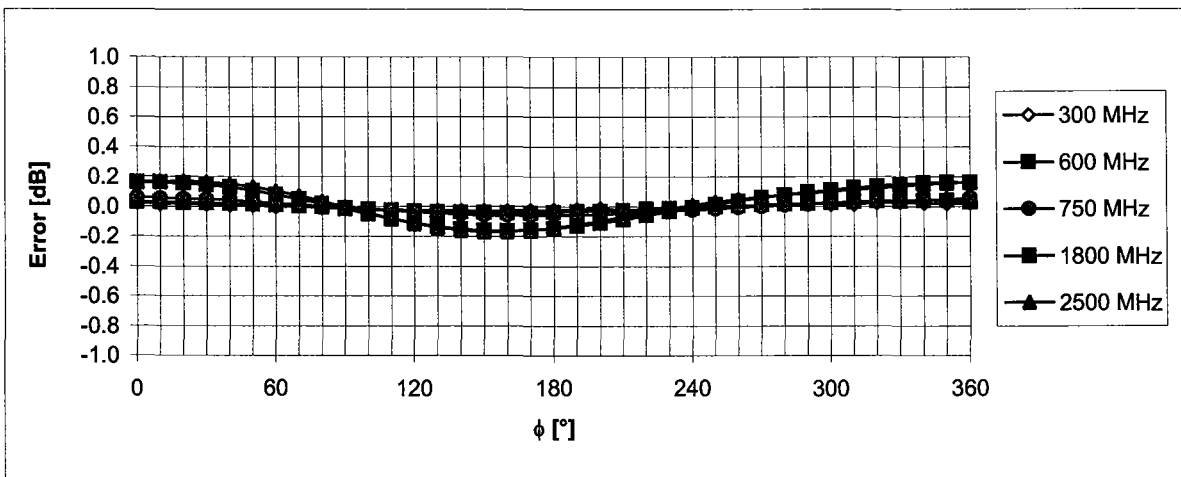


### Receiving Pattern ( $\phi$ ), $\vartheta = 90^\circ$



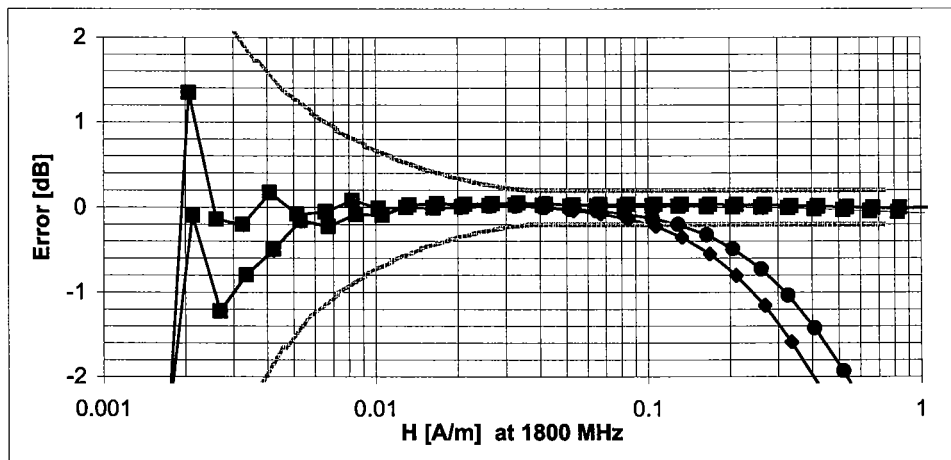
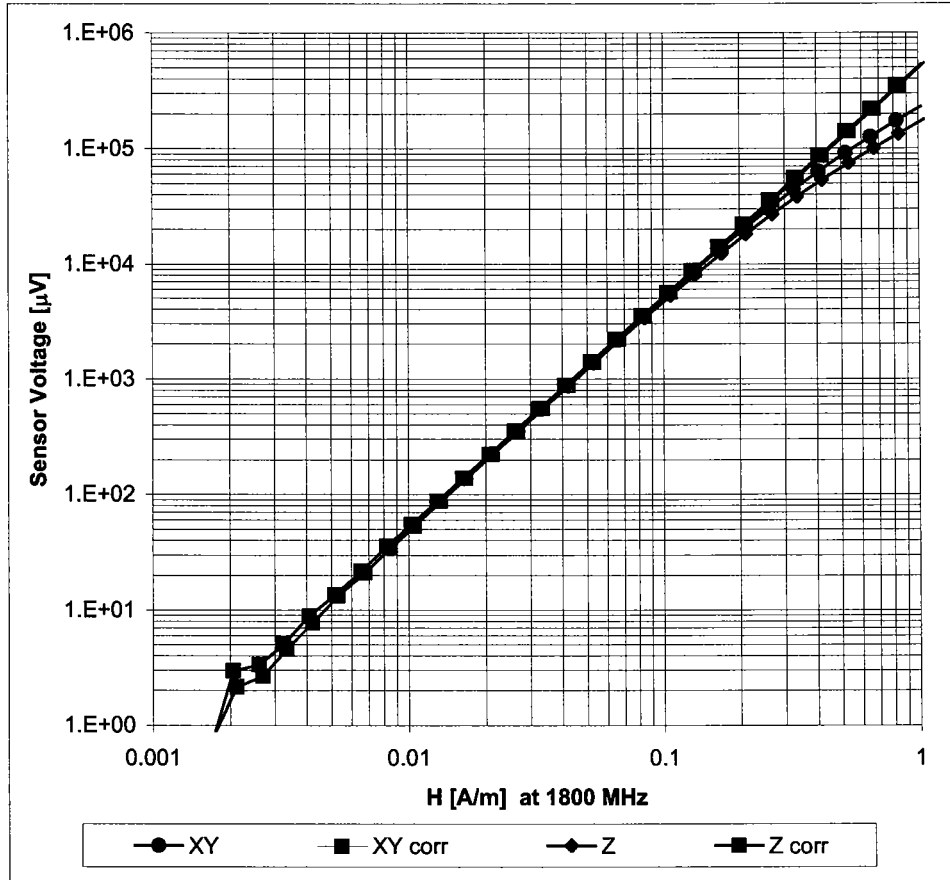
Uncertainty of Axial Isotropy Assessment:  $\pm 0.5\%$  ( $k=2$ )

### Receiving Pattern ( $\phi$ ), $\vartheta = 0^\circ$



Uncertainty of Axial Isotropy Assessment:  $\pm 0.5\%$  ( $k=2$ )

### Dynamic Range f(H-field) (Waveguide R22, f = 1800 MHz)



Uncertainty of Linearity Assessment:  $\pm 0.6\%$  ( $k=2$ )