



# Spot Check Evaluation

**APPLICANT** : Motorola Mobility LLC  
**EQUIPMENT** : Mobile Cellular Phone  
**BRAND NAME** : Motorola  
**MODEL NAME** : XT2527-2  
**FCC ID** : IHDT56AV4  
**STANDARD** : 47 CFR Part 22(H), 24(E), 27(M), 27(Q), 90(S)  
47 CFR Part 15 Subpart C §15.225  
47 CFR Part 15 Subpart C §15.247  
47 CFR Part 15 Subpart E §15.407  
**TEST DATE(S)** : Apr. 05, 2025 ~ Apr. 27, 2025

We, Sporton International Inc. (Kunshan), would like to declare that the tested sample has been evaluated in accordance with the test procedures and has been in compliance with the applicable technical standards.

This report contains data that were produced under subcontract by Sporton International Inc. (ShenZhen)

The test results in this report apply exclusively to the tested model / sample. Without written approval of Sporton International Inc. (Kunshan), the test report shall not be reproduced except in full.

Jason Jia

Approved by: Jason Jia



**Sporton International Inc. (Kunshan)**

No. 1098, Pengxi North Road, Kunshan Economic Development Zone Jiangsu Province 215300  
People's Republic of China



# TABLE OF CONTENTS

**REVISION HISTORY..... 3**

**1 GENERAL DESCRIPTION..... 4**

1.1 Applicant ..... 4

1.2 Manufacturer..... 4

1.3 Product Feature of Equipment Under Test..... 4

1.4 Modification of EUT ..... 4

1.5 Testing Site..... 5

1.6 Test Software..... 5

1.7 Applicable Standards..... 6

1.8 Specification of Accessory..... 6

**2 RE-USE OF MEASURED DATA..... 7**

2.1 Introduction Section ..... 7

2.2 Model Difference Information ..... 7

2.3 Reference detail Section: ..... 8

2.4 Spot Check Verification Data Section..... 9

**3 LIST OF MEASURING EQUIPMENT..... 13**

**4 MEASUREMENT UNCERTAINTY ..... 16**

**APPENDIX A. RADIATED SPURIOUS EMISSION**

**APPENDIX B. SETUP PHOTOGRAPHS**

**APPENDIX C. REFERENCE REPORT**





# 1 General Description

## 1.1 Applicant

Motorola Mobility LLC  
222 W,Merchandise Mart Plaza, Chicago IL 60654 USA

## 1.2 Manufacturer

Motorola Mobility LLC  
222 W,Merchandise Mart Plaza, Chicago IL 60654 USA

## 1.3 Product Feature of Equipment Under Test

Product Feature	
Equipment	Mobile Cellular Phone
Brand Name	Motorola
Model Name	XT2527-2
FCC ID	IHDT56AV4
IMEI Code	Conducted/DFS: 258674600017032/258674600017040 Radiation: 358674600016810/358674600016828 Conduction: 358674600016612/358674600016620
HW Version	DVT2
SW Version	V2VN35.50
EUT Stage	Identical Prototype

Remark: The above EUT's information was declared by manufacturer. Please refer to the specifications or user's manual for more detailed description.

## 1.4 Modification of EUT

No modifications are made to the EUT during all test items.



### 1.5 Testing Site

Sporton International Inc. (Kunshan) is accredited to ISO/IEC 17025:2017 by American Association for Laboratory Accreditation with Certificate Number 5145.02.

<b>Test Firm</b>	Sporton International Inc. (Kunshan)		
<b>Test Site Location</b>	No. 1098, Pengxi North Road, Kunshan Economic Development Zone Jiangsu Province 215300 People's Republic of China TEL : +86-512-57900158		
<b>Test Site No.</b>	<b>Sporton Site No.</b>	<b>FCC Designation No.</b>	<b>FCC Test Firm Registration No.</b>
	TH01-KS DFS01-KS	CN1257	314309

Sporton International Inc. (Shenzhen) is accredited to ISO/IEC 17025:2017 by American Association for Laboratory Accreditation with Certificate Number 5145.01.

<b>Test Firm</b>	Sporton International Inc. (Shenzhen)		
<b>Test Site Location</b>	101, 1st Floor, Block B, Building 1, No. 2, Tengfeng 4th Road, Fenghuang Community, Fuyong Street, Baoan District, Shenzhen City, Guangdong Province 518103 People's Republic of China TEL: +86-755-86066985		
<b>Test Site No.</b>	<b>Sporton Site No.</b>	<b>FCC Designation No.</b>	<b>FCC Test Firm Registration No.</b>
	CO02-SZ 03CH02-SZ 03CH03-SZ 03CH05-SZ	CN1256	421272

### 1.6 Test Software

Item	Site	Manufacturer	Name	Version
1.	TH01-KS	SPORTON	FCC 15C-15E Test Tools Ver10.0_210607	10.0
2.	DFS01-KS	Sporton	Test Tools	1.0
3.	03CH02-SZ	AUDIX	E3	6.2009-8-24a
4.	03CH03-SZ	AUDIX	E3	6.2009-8-24
5.	03CH05-SZ	AUDIX	E3	6.2009-8-24a1
6.	CO02-SZ	AUDIX	E3	6.120613b

## 1.7 Applicable Standards

According to the specifications of the manufacturer, the EUT must comply with the requirements of the following standards:

- FCC KDB 484596 D01 Referencing Test Data v02r03
- 47 CFR Part 22(H), 24(E), 27(M), 27(Q), 90(S)
- 47 CFR Part 15 Subpart C §15.225
- 47 CFR Part 15 Subpart C §15.247
- 47 CFR Part 15 Subpart E §15.407
- ANSI C63.10-2013
- ANSI C63.26-2015

## 1.8 Specification of Accessory

Specification of Accessory				
AC Adapter 1(US)	Brand Name	Motorola(Salcomp)	Model Name	MC-331L
AC Adapter 1(EU)	Brand Name	Motorola(Salcomp)	Model Name	MC-332L
AC Adapter 1(UK)	Brand Name	Motorola(Salcomp)	Model Name	MC-333L
AC Adapter 1(AU)	Brand Name	Motorola(Salcomp)	Model Name	MC-335L
AC Adapter 1(AR)	Brand Name	Motorola(Salcomp)	Model Name	MC-336L
AC Adapter 1(BR)	Brand Name	Motorola(Salcomp)	Model Name	MC-337L
AC Adapter 2(US)	Brand Name	Motorola(Chenyang)	Model Name	MC-331L
AC Adapter 2(EU)	Brand Name	Motorola(Chenyang)	Model Name	MC-332L
AC Adapter 2(UK)	Brand Name	Motorola(Chenyang)	Model Name	MC-333L
AC Adapter 2(AR)	Brand Name	Motorola(Chenyang)	Model Name	MC-336L
AC Adapter 2(BR)	Brand Name	Motorola(Chenyang)	Model Name	MC-337L
Battery 1	Brand Name	Motorola(NVT)	Model Name	RA52
Battery 2	Brand Name	Motorola(SUNWODA)	Model Name	RA52
USB Cable 1	Brand Name	Motorola(Washin)	Model Name	HX-ZN-34
USB Cable 2	Brand Name	Motorola(Juwei)	Model Name	JWUB1928-ZN01H
Earphone	Brand Name	Motorola (Juwei)	Model Name	ZN80400118H001



## 2 Re-use of Measured Data

### 2.1 Introduction Section

This application re-uses data collected on a similar device. The subject device of this application (Model: XT2527-2, FCC ID: IHDT56AV4) is electrically identical to the reference device (Model: XT2527-1, FCC ID: IHDT56AV5) for the portions of the circuitry corresponding to the data being re-used, following the FCC KDB 484596 D01 Referencing Test Data v02r03.

ECR Data Referencing Inquiry has been approved by FCC, and the data referencing and spot check test plan includes RF/EMC, the details are presented in section 2.3 of this report, and for SAR Reference detail, please refer to FCC SAR report FA530724-01.

The criteria set in section 3 of KDB 484596 D01 v02r03 is followed to determine whether the data referencing is justified. For SAR, the higher between the referenced value and the spot check value is used to determine compliance in both standalone and simultaneous transmission conditions

The applicant takes full responsibility that the test data as referenced in this report represent compliance for this FCC ID: IHDT56AV4 .

### 2.2 Model Difference Information

The **main** difference between FCC ID: IHDT56AV5 and FCC ID: IHDT56AV4 is as below:

- Remove WCDMA B4, LTE B4/12/13/17/25/66 and 5G NR n2/n66.
- Add LTE B20/32/71/38C/41C and 5G NR n8/n20/n71.
- B41/B41C/n77/n78 Enable PC2 by software.
- Add NSA mode for 5G NR n5/n77.

Other differences and all the details of similarity and difference can be found in the confidential documents (IHDT56AV4 Operational Description of Product Equality Declaration).



2.3 Reference detail Section:

Rule Part	Equipment Class	Frequency Band (MHz)	Reference FCC ID (Parent)	Reference on test	Reference Title	FCC ID Filling (Variant)	Test on the variant	Data Referencing (Y/N)
15C	DSS (BR/EDR)	2400~2483.5	IHDT56AV5	Full test	FR530724A	IHDT56AV4	Spot check	Y, All test items
	DTS (BLE)	2400~2483.5	IHDT56AV5	Full test	FR530724B	IHDT56AV4	Spot check	Y, All test items
	DTS (WLAN)	2400~2483.5	IHDT56AV5	Full test	FR530724C	IHDT56AV4	Spot check	Y, All test items
	DXX (NFC)	13.56	IHDT56AV5	Full test	FR530724D	IHDT56AV4	Spot check	Y, All test items
15E	U-NII	5180~5240	IHDT56AV5	Full test	FR530724E	IHDT56AV4	Spot check	Y, All test items
		5260~5320	IHDT56AV5	Full test	FR530724E	IHDT56AV4	Spot check	Y, All test items
		5500~5720	IHDT56AV5	Full test	FR530724E	IHDT56AV4	Spot check	Y, All test items
		5745~5825	IHDT56AV5	Full test	FR530724E	IHDT56AV4	Spot check	Y, All test items
		5260~5320 5500~5720	IHDT56AV5	Full test	FZ530724	IHDT56AV4	Spot check	Y, All test items
22, 24, 27, 90,	PCE (GSM)	GSM 850/1900	IHDT56AV5	Full test	FG530724A	IHDT56AV4	Spot check	Y, All test items
	PCE (WCDMA)	Band II, V	IHDT56AV5	Full test	FG530724A	IHDT56AV4	Spot check	Y, All test items
	PCE (LTE)	B5/26/7/7C/42	IHDT56AV5	Full test	FG530724B FG530724C FG530724E FG530724F	IHDT56AV4	Spot check	Y, All test items
	PCE (LTE)	B26 (90S)	IHDT56AV5	Full test	FG530724D	IHDT56AV4	Spot check	Y, All test items
	PCE (LTE)	B2/38/38C/41/41C/71	-	-	-	-	-	N

Y: Pointer to spot-check exhibit; N: Pointer to full test exhibit

**Remark:** All 5G NR spot check or full test bands are not included in this report and will be issued separately.



### 2.4 Spot Check Verification Data Section

All test items test against the variant model based on the worst-case condition from the original model was performed in this filing to demonstrate the test data from original model remains representative for the variant model.

All test procedures follow the related section of parent report.

Spot-check measurements, while being always compliant with the applicable rule part(s) for the test under consideration, show a deviation  $d_{dB}$  from the reference data no larger than 3 dB:

$$d_{dB} = |V_{dB} - R_{dB}| \leq 3 \text{ dB} \tag{1}$$

$V_{dB}$ , the variant spot-check level

$R_{dB}$ , the corresponding measurement level for the reference model

An alternative to the limit of eq. (1) is available, and is based on considering how far the reference data  $R_{dB}$  is from the compliance threshold  $C_{dB}$  (also expressed in dB), for the particular test under consideration. In this case, if  $M_{dB} = |C_{dB} - R_{dB}|$  is the margin in dB from the compliance limit, a spot check may be considered acceptable when the deviation  $d_{dB}$  from the reference data satisfies the following condition:

$$d_{dB} = |V_{dB} - R_{dB}| \leq (3 + M_{dB} / 20) \text{ dB} , \text{ for } 0 \leq M_{dB} \leq 60 \text{ dB} \tag{2}$$

$$d_{dB} = |V_{dB} - R_{dB}| = 6 \text{ dB} , \text{ for } M_{dB} > 60 \text{ dB}$$

where “| |” is the absolute value of the measured quantity.

When using the option in eq. (2),  $d_{dB}$  increases linearly from 3 dB to 6 dB.

Summary for spot check for each rule entry and technology is listed as below:

Mode	Test Item	IHDT56AV5 Parent Worst mode Test Result	IHDT56AV4 Variant Check Test Result	Deviation (dB)	Deviation Limit (dB)
BT 1Mbps (CH78)	Number of Channels	79	79	0	3
	Hopping Channel Separation	0.991	0.998	0.007	3
	Dwell Time of Each Channel	0.31	0.31	0	3
	20dB Bandwidth	0.86	0.86	0	3
	99% Bandwidth	0.758	0.758	0	3
	Conducted Band Edges	-46.95	-46.67	0.28	3
	Conducted Spurious Emission	-36.21	-36.45	0.24	3
BT 1Mbps (CH78)	Radiated Band Edges and Radiated Spurious Emission	46.35	46.95	0.6	3
BT	AC Conducted Emission	7.98	8.08	0.1	3
BLE 2Mbps (CH38)	6dB Bandwidth	1.18	1.17	0.01	3
	99% Bandwidth	2.054	2.054	0	3
	Power Spectral Density	-5	-5.08	0.08	3
	Conducted Band Edges	-46.83	-47.02	0.19	3
	Conducted Spurious Emission	-35.82	-35.51	0.31	3
BLE 2Mbps (CH39)	Radiated Band Edges and Spurious Emission	41.54	41.29	0.25	3
BLE	AC Conducted Emission	7.98	8.08	0.1	3
WIFI 2.4G	6dB Bandwidth	17.24	17.96	0.72	3



(802.11ax20 CH01)	99% Bandwidth	19.341	19.5	0.159	3
	Power Spectral Density	-7.83	-8.05	0.22	3
	Conducted Band Edges	-18.38	-18.82	0.44	3
	Conducted Spurious Emission	-36.09	-35.22	0.87	3
WIFI 2.4G (802.11g CH11)	Radiated Band Edges and Spurious Emission	50.75	49.21	1.54	3
WIFI 2.4G	AC Conducted Emission	7.98	8.08	0.1	3
FCC-WIFI 5G (802.11ax20 CH149)	26dB Bandwidth	29	28.06	0.94	3
FCC-WIFI 5G (802.11ax20 CH149)	99% Bandwidth	19.341	19.295	0.046	3
FCC-WIFI 5G (802.11ax20 CH149)	Power Spectral Density	3.98	3.93	0.05	3
FCC-WIFI 5G (802.11ax20 CH149)	Unwanted Emissions	17.52	18.14	0.62	3
WIFI 5G (802.11ax HE80 CH106)	DFS	0.91522	0.830828	0.084392	3
5G WIFI 11ax HE20_CH64	Radiated Band Edges and Spurious Emission	50.65	50.01	0.64	3
WIFI 5G	AC Conducted Emission	8.68	9.38	0.7	3
NFC	20dB Emission Bandwidth (MHz)	2.48	2.48	0	3
	99% Occupied Bandwidth (MHz)	2.10	2.11	0.01	3
	Frequency Stability	-0.5531	-0.5045	0.0486	3
	Field Strength of Fundamental (dBuV/m)	55.24	55.48	0.24	3
	Radiated Spurious Emissions (dBuV/m)	36.16	33.85	2.31	3
	AC Power Line Conducted Emissions(dBuV)	9.75	8.40	1.35	3
Part 22/24/27/90 (LTE Band 7C)	Equivalent Isotropic Radiated Power	20.47	20.15	0.32	3
	Peak-to-Average Ratio	6.41	6.22	0.19	3
	Occupied Bandwidth	28.77	28.89	0.12	3
	Conducted Band Edge	-26.22	-27.35	1.13	3
	Conducted Spurious Emission	-51.75	-53.16	1.41	3
Frequency Stability	0.0012	0.0027	0.0015	3	
Part 22/24/27/90 (GSM 850)	Radiated Spurious Emission	-34.48	-32.78	1.7	3



Test Item	Mode	IHDT56AV5 Parent Worst mode Test Result	IHDT56AV4 Variant Check Test Result	Deviation (dB)	Deviation Limit (dB)
Conducted Power (dBm)	BT BR/EDR	16.74	15.87	0.87	3
	BLE 1Mbps	11.92	11.67	0.25	3
	BLE 2Mbps	11.96	11.64	0.32	3
	11b, 2.4GHz	18.51	18.18	0.33	3
	11g, 2.4GHz	18.57	18.47	0.10	3
	11n HT20, 2.4GHz	18.59	18.25	0.34	3
	11n HT40, 2.4GHz	16.86	16.59	0.33	3
	11ax HE20, 2.4GHz	18.69	18.50	0.19	3
	11ax HE40, 2.4GHz	17.05	17.59	0.54	3
	11a, 5.2GHz	18.24	18.21	0.03	3
	11a, 5.3GHz	18.30	18.26	0.04	3
	11a, 5.5GHz	18.01	17.96	0.05	3
	11a, 5.8GHz	17.92	17.86	0.06	3
	11n HT20, 5.2GHz	18.07	17.92	0.15	3
	11n HT20, 5.3GHz	18.27	18.11	0.16	3
	11n HT20, 5.5GHz	18.08	17.97	0.11	3
	11n HT20, 5.8GHz	17.81	17.61	0.20	3
	11ac VHT20, 5.2GHz	18.12	18.04	0.08	3
	11ac VHT20, 5.3GHz	18.34	18.21	0.13	3
	11ac VHT20, 5.5GHz	18.12	18.03	0.09	3
	11ac VHT20, 5.8GHz	17.88	17.81	0.07	3
	11ax HE20, 5.2GHz	18.23	18.18	0.05	3
	11ax HE20, 5.3GHz	18.41	18.36	0.05	3
	11ax HE20, 5.5GHz	18.21	18.18	0.03	3
	11ax HE20, 5.8GHz	17.97	17.93	0.04	3
	11n HT40, 5.2GHz	17.29	17.21	0.08	3
	11n HT40, 5.3GHz	17.70	17.62	0.08	3
	11n HT40, 5.5GHz	17.19	17.07	0.12	3
	11n HT40, 5.8GHz	17.18	17.12	0.06	3
	11ac VHT40, 5.2GHz	17.36	17.35	0.01	3
	11ac VHT40, 5.3GHz	17.73	17.71	0.02	3
	11ac VHT40, 5.5GHz	17.25	17.21	0.04	3
	11ac VHT40, 5.8GHz	17.24	17.22	0.02	3
	11ax HE40, 5.2GHz	17.47	17.41	0.06	3
	11ax HE40, 5.3GHz	17.82	17.77	0.05	3
	11ax HE40, 5.5GHz	17.37	17.34	0.03	3
	11ax HE40, 5.8GHz	17.34	17.30	0.04	3
	11ac VHT80, 5.2GHz	16.33	16.26	0.07	3
	11ac VHT80, 5.3GHz	16.46	16.30	0.16	3
	11ac VHT80, 5.5GHz	16.27	16.23	0.04	3
	11ac VHT80, 5.8GHz	16.20	16.19	0.01	3
	11ax HE80, 5.2GHz	16.43	16.38	0.05	3
	11ax HE80, 5.3GHz	16.58	16.55	0.03	3
	11ax HE80, 5.5GHz	16.38	16.34	0.04	3
	11ax HE80, 5.8GHz	16.33	16.30	0.03	3
GSM 850	31.76	31.65	0.11	3	
GSM 1900	28.52	28.24	0.28	3	
WCDMA 850	22.58	22.53	0.05	3	
WCDMA 1900	22.70	22.65	0.05	3	
LTE B5	22.59	22.49	0.1	3	
LTE B26	22.65	22.54	0.11	3	



	LTE B26-90S	22.81	22.48	0.33	3
	LTE B7	22.84	22.72	0.12	3
	LTE B42	23.04	22.92	0.12	3
	LTE B7C	22.77	22.45	0.32	3

Conclusion:

All test items test against the variant model based on the worst-case condition from the original model was performed in this filing to demonstrate the test data from original model remains representative for the variant model.

Based on the spot check test result, the test data from the original model is representative for the variant model. All spot check test data are shown within expected level compliant to limit line.

We are using power and ERP/EIRP measurements from the original parent model reports to list on the grant.

We confirm that the test data referencing policy of FCC KDB 484596 D01 Referencing Test Data v02r03 has been followed and the test data as referenced from the parent model report represents compliance with new FCC ID.



### 3 List of Measuring Equipment

For BT/WIFI:

Instrument	Manufacturer	Model No.	Serial No.	Characteristics	Calibration Date	Test Date	Due Date	Remark
Spectrum Analyzer	R&S	FSV40	101040	10Hz~40GHz	Oct. 10, 2024	Apr. 23, 2025	Oct. 09, 2025	Conducted (TH01-KS)
Pulse Power Sensor	Anritsu	MA2411B	0917070	300MHz~40GHz	Jan. 02, 2025	Apr. 23, 2025	Jan. 01, 2026	Conducted (TH01-KS)
Power Meter	Anritsu	ML2495A	1005002	50MHz Bandwidth	Jan. 02, 2025	Apr. 23, 2025	Jan. 01, 2026	Conducted (TH01-KS)
EMI Test Receiver&SA	KEYSIGHT	N9038A	MY54450083	20Hz~8.4GHz	Apr. 08, 2025	Apr. 16, 2025	Apr. 07, 2026	Radiation (03CH03-SZ)
EXA Spectrum Analyzer	KEYSIGHT	N9010A	MY55150246	10Hz~44GHz;	Apr. 08, 2025	Apr. 16, 2025	Apr. 07, 2026	Radiation (03CH03-SZ)
Loop Antenna	R&S	HFH2-Z2E	101141	9kHz~30MHz	Dec. 28, 2024	Apr. 16, 2025	Dec. 27, 2025	Radiation (03CH03-SZ)
Bilog Antenna	TeseQ	CBL6112D	35408	30MHz~2GHz	Aug. 20, 2023	Apr. 16, 2025	Aug. 19, 2025	Radiation (03CH03-SZ)
Double Ridge Horn Antenna	SCHWARZBECK	BBHA9120D	9120D-1355	1GHz~18GHz	Apr. 08, 2025	Apr. 16, 2025	Apr. 07, 2026	Radiation (03CH03-SZ)
HF Amplifier	MITEQ	TTA1840-35-HG	1871923	18GHz~40GHz	Jul. 03, 2024	Apr. 16, 2025	Jul. 02, 2025	Radiation (03CH03-SZ)
SHF-EHF Horn	com-power	AH-840	101071	18GHz~40GHz	Apr. 08, 2025	Apr. 16, 2025	Apr. 07, 2026	Radiation (03CH03-SZ)
Amplifier	Burgeon	BPA-530	102211	0.01Hz~3000MHz	Oct. 18, 2024	Apr. 16, 2025	Oct. 17, 2025	Radiation (03CH03-SZ)
HF Amplifier	MITEQ	AMF-7D-00101800-30-10P-R	1943528	1GHz~18GHz	Oct. 14, 2024	Apr. 16, 2025	Oct. 13, 2025	Radiation (03CH03-SZ)
Amplifier	Agilent Technologies	83017A	MY39501302	500MHz~26.5GHz	Dec. 27, 2023	Apr. 16, 2025	Dec. 26, 2024	Radiation (03CH03-SZ)
AC Power Source	Chroma	61601	616010002729	N/A	Oct. 18, 2024	Apr. 16, 2025	Oct. 17, 2025	Radiation (03CH03-SZ)
Turn Table	EM	EM1000	N/A	0~360 degree	NCR	Apr. 16, 2025	NCR	Radiation (03CH03-SZ)
Antenna Mast	EM	EM1000	N/A	1 m~4 m	NCR	Apr. 16, 2025	NCR	Radiation (03CH03-SZ)
EMI Receiver	R&S	ESR7	102297	9kHz~7GHz;	Jul. 03, 2024	Apr. 17, 2025	Jul. 02, 2025	Conduction (CO02-SZ)
AC LISN	R&S	ENV216	101499	9kHz~30MHz	Jul. 03, 2024	Apr. 17, 2025	Jul. 02, 2025	Conduction (CO02-SZ)
AC Power Source	CHROMA	61601	616010002470	100Vac~250Vac	Dec. 25, 2024	Apr. 17, 2025	Dec. 24, 2025	Conduction (CO02-SZ)
Spectrum Analyzer	R&S	FSV7	101632	10Hz~7GHz	Jan. 03, 2025	Apr. 16, 2025	Jan. 02, 2026	Conducted (DFS01-KS)
Signal Generator	KEYSIGHT	N5182B	MY53050604	9KHz~6GHz	Apr. 17, 2024	Apr. 16, 2025	Apr. 16, 2025	Conducted (DFS01-KS)
Combiner	MTJ Cooperation	MTJ7112	N/A	0.4-6GHz	NCR	Apr. 16, 2025	NCR	Conducted (DFS01-KS)

NCR: No Calibration Required.



For NFC:

Instrument	Manufacturer	Model No.	Serial No.	Characteristics	Calibration Date	Test Date	Due Date	Remark
EMI Test Receiver	R&S	ESR7	102261	9kHz~7GHz	Apr. 08, 2025	Apr. 23, 2025	Apr. 07, 2026	Radiation (03CH05-SZ)
EXA Spectrum Analyzer	KEYSIGHT	N9010B	MY59071191	10Hz~44GHz	Apr. 08, 2025	Apr. 23, 2025	Apr. 07, 2026	Radiation (03CH05-SZ)
Loop Antenna	R&S	HFH2-Z2E	101141	9kHz~30MHz	Dec. 28, 2024	Apr. 23, 2025	Dec. 27, 2025	Radiation (03CH05-SZ)
Log-periodic Antenna	SCHWARZBECK	VULB 9168	01001	20MHz~1.5GHz	Jul. 08, 2024	Apr. 23, 2025	Jul. 07, 2025	Radiation (03CH05-SZ)
Amplifier	EM Electronics	EM330	060756	0.01Hz~3000MHz	Apr. 08, 2025	Apr. 23, 2025	Apr. 07, 2026	Radiation (03CH05-SZ)
AC Power Source	APC	AFV-S-600	F119050013	N/A	Oct. 14, 2024	Apr. 23, 2025	Oct. 13, 2025	Radiation (03CH05-SZ)
Turn Table	EMEC	T-200-S-1	060925-T	0~360 degree	NCR	Apr. 23, 2025	NCR	Radiation (03CH05-SZ)
Antenna Mast	EMEC	MBS-400-1	060927	1 m~4 m	NCR	Apr. 23, 2025	NCR	Radiation (03CH05-SZ)
Spectrum Analyzer	R&S	FSV40	101040	10Hz~40GHz	Oct. 10, 2024	Apr. 23, 2025	Oct. 09, 2025	Conducted (TH01-KS)
DC Power Supply	GW INSTEK	PLR36-10	GET220683	Max 20A, 36V	Jan. 02, 2025	Apr. 23, 2025	Jan. 01, 2026	Conducted (TH01-KS)
Temperature & humidity chamber	Hongzhan	LP-150U	H2014011440	-40~+150°C 20%~95%RH	Jul. 04, 2024	Apr. 23, 2025	Jul. 03, 2025	Conducted (TH01-KS)
EMI Receiver	R&S	ESR7	102297	9kHz~7GHz;	Jul. 03, 2024	Apr. 17, 2025	Jul. 02, 2025	Conduction (CO02-SZ)
AC LISN	R&S	ENV216	101499	9kHz~30MHz	Jul. 03, 2024	Apr. 17, 2025	Jul. 02, 2025	Conduction (CO02-SZ)
AC Power Source	CHROMA	61601	616010002470	100Vac~250Vac	Dec.25, 2024	Apr. 17, 2025	Dec. 24, 2025	Conduction (CO02-SZ)

NCR: No Calibration Required.



For WWAN Bands:

Instrument	Manufacturer	Model No.	Serial No.	Characteristics	Calibration Date	Test Date	Due Date	Remark
Spectrum Analyzer	R&S	FSV40	101040	10Hz~40GHz	Oct. 10, 2024	Apr. 22, 2025~ Apr. 23, 2025	Oct. 09, 2025	Conducted (TH01-KS)
Power divider	STI	STI08-0055	-	0.5~40GHz	NCR	Apr. 22, 2025~ Apr. 23, 2025	NCR	Conducted (TH01-KS)
Temperature & humidity chamber	Hongzhan	LP-150U	H2014011 440	-40~+150°C 20%~95%RH	Jul. 04, 2024	Apr. 22, 2025~ Apr. 23, 2025	Jul. 03, 2025	Conducted (TH01-KS)
EXA Spectrum Analyzer	KEYSIGHT	N9010A	MY551502 13	10Hz~44GHz	Jul. 03, 2024	Apr. 16, 2025~ Apr. 27, 2025	Jul. 02, 2025	Radiation (03CH02-SZ)
Loop Antenna	R&S	HFH2-Z2E	101141	9kHz~30MHz	Dec. 28, 2024	Apr. 16, 2025~ Apr. 27, 2025	Dec. 27, 2025	Radiation (03CH02-SZ)
Bilog Antenna	TeseQ	CBL6112D	35407	30MHz-2GHz	Oct. 24, 2023	Apr. 16, 2025~ Apr. 27, 2025	Oct. 23, 2025	Radiation (03CH02-SZ)
Double Ridge Horn Antenna	ETS-Lindgren	3117	00119436	1GHz~18GHz	Jul. 04, 2024	Apr. 16, 2025~ Apr. 27, 2025	Jul. 04, 2025	Radiation (03CH02-SZ)
HF Amplifier	MITEQ	TTA1840-35-HG	1871923	18GHz~40GHz	Jul. 03, 2024	Apr. 16, 2025~ Apr. 27, 2025	Jul. 03, 2025	Radiation (03CH02-SZ)
SHF-EHF Horn	com-power	AH-840	101071	18Ghz-40GHz	Apr. 08, 2025	Apr. 16, 2025~ Apr. 27, 2025	Apr. 07, 2026	Radiation (03CH02-SZ)
LF Amplifier	Burgeon	BPA-530	102211	0.01~3000Mhz	Oct. 18, 2024	Apr. 16, 2025~ Apr. 27, 2025	Oct. 17, 2025	Radiation (03CH02-SZ)
HF Amplifier	KEYSIGHT	83017A	MY532701 05	0.5GHz~26.5GHz	Oct. 14, 2024	Apr. 16, 2025~ Apr. 27, 2025	Oct. 13, 2025	Radiation (03CH02-SZ)
AC Power Source	Chroma	61601	616010003 043	N/A	Oct. 18, 2024	Apr. 16, 2025~ Apr. 27, 2025	Oct. 17, 2025	Radiation (03CH02-SZ)
Turn Table	Chaintek	T-200	N/A	0~360 degree	NCR	Apr. 16, 2025~ Apr. 27, 2025	NCR	Radiation (03CH02-SZ)
Antenna Mast	Chaintek	MBS-400	N/A	1 m~4 m	NCR	Apr. 16, 2025~ Apr. 27, 2025	NCR	Radiation (03CH02-SZ)

NCR: No Calibration Required.



## 4 Measurement Uncertainty

The measurement uncertainties shown below were calculated in accordance with the requirements of ANSI 63.26-2015. All the measurement uncertainty value were shown with a coverage K=2 to indicate 95% level of confidence. The measurement data show herein meets or exceeds the CISPR measurement uncertainty values specified in CISPR 16-4-2 and can be compared directly to specified limit to determine compliance.

### Uncertainty of Conducted Measurement (BT/WIFI2.4G/5G)

Test Item	Uncertainty
Conducted Spurious Emission & Bandedge	±2.22 dB
Occupied Channel Bandwidth	±0.1%
Conducted Power	±0.50 dB
Conducted Power Spectral Density	±0.90 dB
Frequency	±0.04 Hz

### Uncertainty of Conducted Measurement (DFS)

Conducted Generated signal Levels	±0.56 dB
Conducted Time	0.38%

### Uncertainty of Conducted Measurement (NFC)

Test Item	Uncertainty
Occupied Channel Bandwidth	±0.1%
Frequency	±0.04 Hz

### Uncertainty of Conducted Measurement (WWAN)

Test Item	Uncertainty
Conducted Spurious Emission & Bandedge	±2.22 dB
Occupied Channel Bandwidth	±0.1%
Conducted Power	±0.50 dB
Peak to Average Ratio	±0.90 dB
Frequency Stability	±0.04 ppm



**Uncertainty of AC Conducted Emission Measurement (0.15 MHz ~ 30 MHz)**

Measuring Uncertainty for a Level of Confidence of 95% (U = 2Uc(y))	2.5 dB
---	--------

03CH03-SZ(BT/WIF):

**Uncertainty of Radiated Emission Measurement (30 MHz ~ 1000 MHz)**

Measuring Uncertainty for a Level of Confidence of 95% (U = 2Uc(y))	5.00 dB
---	---------

**Uncertainty of Radiated Emission Measurement (1 GHz ~ 18 GHz)**

Measuring Uncertainty for a Level of Confidence of 95% (U = 2Uc(y))	4.90 dB
---	---------

**Uncertainty of Radiated Emission Measurement (18 GHz ~ 40 GHz)**

Measuring Uncertainty for a Level of Confidence of 95% (U = 2Uc(y))	5.00 dB
---	---------

03CH05-SZ(NFC):

**Uncertainty of Radiated Emission Measurement (9 kHz ~ 30 MHz)**

Measuring Uncertainty for a Level of Confidence of 95% (U = 2Uc(y))	2.50 dB
---	---------

**Uncertainty of Radiated Emission Measurement (30 MHz ~ 1000 MHz)**

Measuring Uncertainty for a Level of Confidence of 95% (U = 2Uc(y))	4.20 dB
---	---------

03CH02-SZ(WWAN):

**Uncertainty of Radiated Emission Measurement (30 MHz ~ 1000 MHz)**

Measuring Uncertainty for a Level of Confidence of 95% (U = 2Uc(y))	2.47 dB
---	---------

**Uncertainty of Radiated Emission Measurement (1 GHz ~ 18 GHz)**

Measuring Uncertainty for a Level of Confidence of 95% (U = 2Uc(y))	3.31 dB
---	---------

**Uncertainty of Radiated Emission Measurement (18 GHz ~ 40 GHz)**

Measuring Uncertainty for a Level of Confidence of 95% (U = 2Uc(y))	3.72 dB
---	---------

-THE END-



## Appendix A. Radiated Spurious Emission

Test Engineer :	Shunping You	Relative Humidity :	50%
		Temperature :	20-24°C

### Radiated Spurious Emission Test Modes

Mode	Band	Band (GHz)	Antenna	Modulation	Channel	Frequency	Data Rate	RU	Remark
Mode 1	CO-TX	5.25-5.35	5	802.11ax HE20	64	5320	MCS0	Full	-
		-	-	BT on	-	-	-	-	-
		-	-	NFC on	-	-	-	-	-
		-	-	LTE Band 71	LINK	-	-	-	-
Mode 2	CO-TX	5.25-5.35	5	802.11ax HE20	64	5320	MCS0	Full	-
		-	-	BT on	-	-	-	-	-
		-	-	NFC on	-	-	-	-	-
		-	-	LTE Band 41	LINK	-	-	-	-
Mode 3	CO-TX			LF					

### Summary of each worse mode

Mode	Modulation	Ch.	Freq. (MHz)	Level (dBuV/m)	Limit (dBuV/m)	Margin (dB)	Pol.	Peak Avg.	Result	Remark
1	802.11ax HE20	64	5350.24	49.99	54.00	-4.01	H	Average	Pass	Band Edge
	802.11ax HE20	64	15960.00	46.33	74.00	-27.67	H	Peak	Pass	Harmonic
2	802.11ax HE20	64	5350.10	49.71	54.00	-4.29	H	AVERAGE	Pass	Band Edge
	802.11ax HE20	64	10640.00	47.57	74.00	-26.43	H	Peak	Pass	Harmonic
3	802.11ax HE20_LF	64	34.85	26.73	40.00	-13.27	V	Peak	Pass	LF

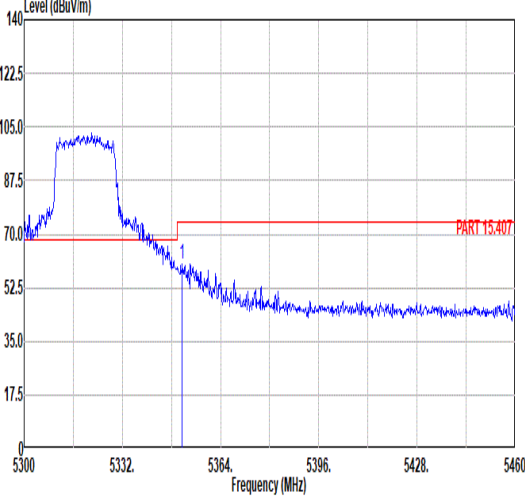
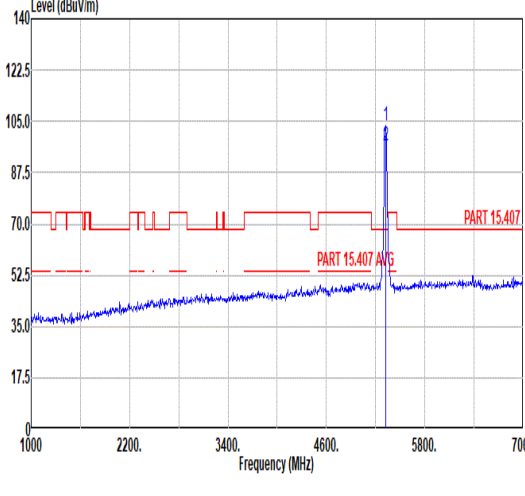
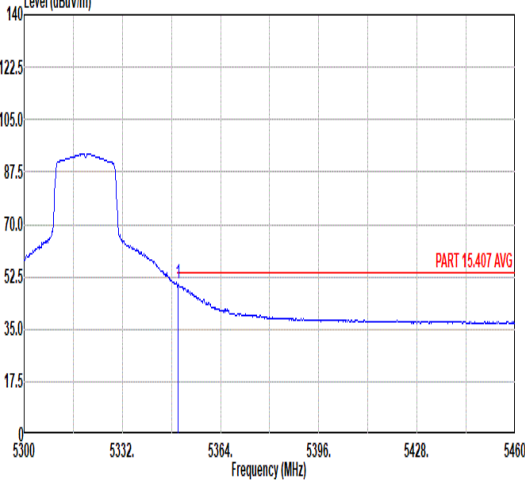

		1																																																																																				
Mode	Band Edge																																																																																					
	LTE Band 71 + 802.11ax HE20 + BT on + NFC on.																																																																																					
ANT	5																																																																																					
Pol.	Horizontal	Fundamental																																																																																				
Peak	 <p>Level (dBuV/m) vs Frequency (MHz) plot showing a peak at 5351.52 MHz. A red limit line is at 74.00 dBuV/m. A blue vertical line marks the peak at 5351.52 MHz.</p> <table border="1"> <thead> <tr> <th>Limit</th> <th>Read</th> <th>Ant</th> <th>Cable</th> <th>Preamp</th> <th>APos</th> <th>TPos</th> <th>Remark</th> </tr> <tr> <th>Freq</th> <th>Level</th> <th>Line Margin</th> <th>Level</th> <th>Factor</th> <th>Loss Factor</th> <th></th> <th></th> </tr> <tr> <th>MHz</th> <th>dBuV/m</th> <th>dBuV/m</th> <th>dB</th> <th>dBuV</th> <th>dB/m</th> <th>dB</th> <th>cm</th> </tr> </thead> <tbody> <tr> <td>1</td> <td>5351.52</td> <td>60.07</td> <td>74.00</td> <td>-13.93</td> <td>50.29</td> <td>34.11</td> <td>8.33</td> <td>32.66</td> <td>161</td> <td>40</td> <td>Peak</td> </tr> </tbody> </table>	Limit	Read	Ant	Cable	Preamp	APos	TPos	Remark	Freq	Level	Line Margin	Level	Factor	Loss Factor			MHz	dBuV/m	dBuV/m	dB	dBuV	dB/m	dB	cm	1	5351.52	60.07	74.00	-13.93	50.29	34.11	8.33	32.66	161	40	Peak	 <p>Level (dBuV/m) vs Frequency (MHz) plot showing a peak at 5320.00 MHz. A red limit line is at 74.00 dBuV/m. A blue vertical line marks the peak at 5320.00 MHz.</p> <table border="1"> <thead> <tr> <th>Limit</th> <th>Read</th> <th>Ant</th> <th>Cable</th> <th>Preamp</th> <th>APos</th> <th>TPos</th> <th>Remark</th> </tr> <tr> <th>Freq</th> <th>Level</th> <th>Line Margin</th> <th>Level</th> <th>Factor</th> <th>Loss Factor</th> <th></th> <th></th> </tr> <tr> <th>MHz</th> <th>dBuV/m</th> <th>dBuV/m</th> <th>dB</th> <th>dBuV</th> <th>dB/m</th> <th>dB</th> <th>cm</th> </tr> </thead> <tbody> <tr> <td>1</td> <td>5320.00</td> <td>103.66</td> <td>74.00</td> <td>29.66</td> <td>93.99</td> <td>34.09</td> <td>8.25</td> <td>32.67</td> <td>161</td> <td>40</td> <td>Peak</td> </tr> <tr> <td>2</td> <td>5320.00</td> <td>96.65</td> <td>74.00</td> <td>22.65</td> <td>86.98</td> <td>34.09</td> <td>8.25</td> <td>32.67</td> <td>161</td> <td>40</td> <td>Average</td> </tr> </tbody> </table>	Limit	Read	Ant	Cable	Preamp	APos	TPos	Remark	Freq	Level	Line Margin	Level	Factor	Loss Factor			MHz	dBuV/m	dBuV/m	dB	dBuV	dB/m	dB	cm	1	5320.00	103.66	74.00	29.66	93.99	34.09	8.25	32.67	161	40	Peak	2	5320.00	96.65	74.00	22.65	86.98	34.09	8.25	32.67	161	40	Average
	Limit	Read	Ant	Cable	Preamp	APos	TPos	Remark																																																																														
Freq	Level	Line Margin	Level	Factor	Loss Factor																																																																																	
MHz	dBuV/m	dBuV/m	dB	dBuV	dB/m	dB	cm																																																																															
1	5351.52	60.07	74.00	-13.93	50.29	34.11	8.33	32.66	161	40	Peak																																																																											
Limit	Read	Ant	Cable	Preamp	APos	TPos	Remark																																																																															
Freq	Level	Line Margin	Level	Factor	Loss Factor																																																																																	
MHz	dBuV/m	dBuV/m	dB	dBuV	dB/m	dB	cm																																																																															
1	5320.00	103.66	74.00	29.66	93.99	34.09	8.25	32.67	161	40	Peak																																																																											
2	5320.00	96.65	74.00	22.65	86.98	34.09	8.25	32.67	161	40	Average																																																																											
Avg	 <p>Level (dBuV/m) vs Frequency (MHz) plot showing an average level at 5350.24 MHz. A red limit line is at 54.00 dBuV/m. A blue vertical line marks the average at 5350.24 MHz.</p> <table border="1"> <thead> <tr> <th>Limit</th> <th>Read</th> <th>Ant</th> <th>Cable</th> <th>Preamp</th> <th>APos</th> <th>TPos</th> <th>Remark</th> </tr> <tr> <th>Freq</th> <th>Level</th> <th>Line Margin</th> <th>Level</th> <th>Factor</th> <th>Loss Factor</th> <th></th> <th></th> </tr> <tr> <th>MHz</th> <th>dBuV/m</th> <th>dBuV/m</th> <th>dB</th> <th>dBuV</th> <th>dB/m</th> <th>dB</th> <th>cm</th> </tr> </thead> <tbody> <tr> <td>1</td> <td>5350.24</td> <td>49.99</td> <td>54.00</td> <td>-4.01</td> <td>40.21</td> <td>34.11</td> <td>8.33</td> <td>32.66</td> <td>161</td> <td>40</td> <td>Average</td> </tr> </tbody> </table>	Limit	Read	Ant	Cable	Preamp	APos	TPos	Remark	Freq	Level	Line Margin	Level	Factor	Loss Factor			MHz	dBuV/m	dBuV/m	dB	dBuV	dB/m	dB	cm	1	5350.24	49.99	54.00	-4.01	40.21	34.11	8.33	32.66	161	40	Average	Blank																																																
Limit	Read	Ant	Cable	Preamp	APos	TPos	Remark																																																																															
Freq	Level	Line Margin	Level	Factor	Loss Factor																																																																																	
MHz	dBuV/m	dBuV/m	dB	dBuV	dB/m	dB	cm																																																																															
1	5350.24	49.99	54.00	-4.01	40.21	34.11	8.33	32.66	161	40	Average																																																																											



Mode	1																																																																																	
	Band Edge																																																																																	
	LTE Band 71 + 802.11ax HE20 + BT on + NFC on.																																																																																	
ANT	5																																																																																	
Pol.	Vertical	Fundamental																																																																																
Peak	<table border="1"> <thead> <tr> <th>Limit</th> <th>Read</th> <th>Ant</th> <th>Cable</th> <th>Preamp</th> <th>APos</th> <th>TPos</th> <th>Remark</th> </tr> <tr> <th>Freq</th> <th>Level</th> <th>Line Margin</th> <th>Level</th> <th>Factor</th> <th>Loss Factor</th> <th></th> <th></th> </tr> <tr> <th>MHz</th> <th>dBuV/m</th> <th>dBuV/m</th> <th>dB</th> <th>dBuV</th> <th>dB/m</th> <th>dB</th> <th>cm</th> <th>deg</th> </tr> </thead> <tbody> <tr> <td>1 5354.72</td> <td>98.84</td> <td>74.00</td> <td>-17.77</td> <td>46.44</td> <td>34.11</td> <td>8.34</td> <td>32.66</td> <td>115</td> <td>266 Peak</td> </tr> </tbody> </table>	Limit	Read	Ant	Cable	Preamp	APos	TPos	Remark	Freq	Level	Line Margin	Level	Factor	Loss Factor			MHz	dBuV/m	dBuV/m	dB	dBuV	dB/m	dB	cm	deg	1 5354.72	98.84	74.00	-17.77	46.44	34.11	8.34	32.66	115	266 Peak	<table border="1"> <thead> <tr> <th>Limit</th> <th>Read</th> <th>Ant</th> <th>Cable</th> <th>Preamp</th> <th>APos</th> <th>TPos</th> <th>Remark</th> </tr> <tr> <th>Freq</th> <th>Level</th> <th>Line Margin</th> <th>Level</th> <th>Factor</th> <th>Loss Factor</th> <th></th> <th></th> </tr> <tr> <th>MHz</th> <th>dBuV/m</th> <th>dBuV/m</th> <th>dB</th> <th>dBuV</th> <th>dB/m</th> <th>dB</th> <th>cm</th> <th>deg</th> </tr> </thead> <tbody> <tr> <td>1 5320.00</td> <td>98.84</td> <td>70.00</td> <td>28.84</td> <td>89.17</td> <td>34.09</td> <td>8.25</td> <td>32.67</td> <td>115</td> <td>266 Peak</td> </tr> <tr> <td>2 5320.00</td> <td>92.32</td> <td>70.00</td> <td>22.32</td> <td>82.65</td> <td>34.09</td> <td>8.25</td> <td>32.67</td> <td>115</td> <td>266 Average</td> </tr> </tbody> </table>	Limit	Read	Ant	Cable	Preamp	APos	TPos	Remark	Freq	Level	Line Margin	Level	Factor	Loss Factor			MHz	dBuV/m	dBuV/m	dB	dBuV	dB/m	dB	cm	deg	1 5320.00	98.84	70.00	28.84	89.17	34.09	8.25	32.67	115	266 Peak	2 5320.00	92.32	70.00	22.32	82.65	34.09	8.25	32.67	115	266 Average
	Limit	Read	Ant	Cable	Preamp	APos	TPos	Remark																																																																										
Freq	Level	Line Margin	Level	Factor	Loss Factor																																																																													
MHz	dBuV/m	dBuV/m	dB	dBuV	dB/m	dB	cm	deg																																																																										
1 5354.72	98.84	74.00	-17.77	46.44	34.11	8.34	32.66	115	266 Peak																																																																									
Limit	Read	Ant	Cable	Preamp	APos	TPos	Remark																																																																											
Freq	Level	Line Margin	Level	Factor	Loss Factor																																																																													
MHz	dBuV/m	dBuV/m	dB	dBuV	dB/m	dB	cm	deg																																																																										
1 5320.00	98.84	70.00	28.84	89.17	34.09	8.25	32.67	115	266 Peak																																																																									
2 5320.00	92.32	70.00	22.32	82.65	34.09	8.25	32.67	115	266 Average																																																																									
Avg	<table border="1"> <thead> <tr> <th>Limit</th> <th>Read</th> <th>Ant</th> <th>Cable</th> <th>Preamp</th> <th>APos</th> <th>TPos</th> <th>Remark</th> </tr> <tr> <th>Freq</th> <th>Level</th> <th>Line Margin</th> <th>Level</th> <th>Factor</th> <th>Loss Factor</th> <th></th> <th></th> </tr> <tr> <th>MHz</th> <th>dBuV/m</th> <th>dBuV/m</th> <th>dB</th> <th>dBuV</th> <th>dB/m</th> <th>dB</th> <th>cm</th> <th>deg</th> </tr> </thead> <tbody> <tr> <td>1 5350.08</td> <td>45.73</td> <td>54.00</td> <td>-8.27</td> <td>35.95</td> <td>34.11</td> <td>8.33</td> <td>32.66</td> <td>115</td> <td>266 Average</td> </tr> </tbody> </table>	Limit	Read	Ant	Cable	Preamp	APos	TPos	Remark	Freq	Level	Line Margin	Level	Factor	Loss Factor			MHz	dBuV/m	dBuV/m	dB	dBuV	dB/m	dB	cm	deg	1 5350.08	45.73	54.00	-8.27	35.95	34.11	8.33	32.66	115	266 Average	Blank																																													
Limit	Read	Ant	Cable	Preamp	APos	TPos	Remark																																																																											
Freq	Level	Line Margin	Level	Factor	Loss Factor																																																																													
MHz	dBuV/m	dBuV/m	dB	dBuV	dB/m	dB	cm	deg																																																																										
1 5350.08	45.73	54.00	-8.27	35.95	34.11	8.33	32.66	115	266 Average																																																																									



Mode	1																																																																																										
	Harmonic																																																																																										
	LTE Band 71 + 802.11ax HE20 + BT on + NFC on.																																																																																										
ANT	5																																																																																										
Pol.	Horizontal	Vertical																																																																																									
Peak Avg																																																																																											
	<table border="1"> <thead> <tr> <th></th> <th>Limit</th> <th>Read</th> <th>Ant</th> <th>Cable</th> <th>Preamp</th> <th>APos</th> <th>TPos</th> <th></th> </tr> <tr> <th>Freq</th> <th>Level</th> <th>Line Margin</th> <th>Level Factor</th> <th>Loss Factor</th> <th></th> <th></th> <th></th> <th>Remark</th> </tr> <tr> <th>MHz</th> <th>dBuV/m</th> <th>dBuV/m</th> <th>dB</th> <th>dBuV</th> <th>dB/m</th> <th>dB</th> <th>cm</th> <th>deg</th> </tr> </thead> <tbody> <tr> <td>1 10640.00</td> <td>46.26</td> <td>74.00</td> <td>-27.74</td> <td>56.23</td> <td>37.78</td> <td>10.94</td> <td>58.69</td> <td>-- -- Peak</td> </tr> <tr> <td>2 15960.00</td> <td>46.33</td> <td>74.00</td> <td>-27.67</td> <td>53.41</td> <td>39.59</td> <td>12.70</td> <td>59.37</td> <td>-- -- Peak</td> </tr> </tbody> </table>		Limit	Read	Ant	Cable	Preamp	APos	TPos		Freq	Level	Line Margin	Level Factor	Loss Factor				Remark	MHz	dBuV/m	dBuV/m	dB	dBuV	dB/m	dB	cm	deg	1 10640.00	46.26	74.00	-27.74	56.23	37.78	10.94	58.69	-- -- Peak	2 15960.00	46.33	74.00	-27.67	53.41	39.59	12.70	59.37	-- -- Peak	<table border="1"> <thead> <tr> <th></th> <th>Limit</th> <th>Read</th> <th>Ant</th> <th>Cable</th> <th>Preamp</th> <th>APos</th> <th>TPos</th> <th></th> </tr> <tr> <th>Freq</th> <th>Level</th> <th>Line Margin</th> <th>Level Factor</th> <th>Loss Factor</th> <th></th> <th></th> <th></th> <th>Remark</th> </tr> <tr> <th>MHz</th> <th>dBuV/m</th> <th>dBuV/m</th> <th>dB</th> <th>dBuV</th> <th>dB/m</th> <th>dB</th> <th>cm</th> <th>deg</th> </tr> </thead> <tbody> <tr> <td>1 10640.00</td> <td>46.15</td> <td>74.00</td> <td>-27.85</td> <td>56.12</td> <td>37.78</td> <td>10.94</td> <td>58.69</td> <td>-- -- Peak</td> </tr> <tr> <td>2 15960.00</td> <td>46.03</td> <td>74.00</td> <td>-27.97</td> <td>53.11</td> <td>39.59</td> <td>12.70</td> <td>59.37</td> <td>-- -- Peak</td> </tr> </tbody> </table>		Limit	Read	Ant	Cable	Preamp	APos	TPos		Freq	Level	Line Margin	Level Factor	Loss Factor				Remark	MHz	dBuV/m	dBuV/m	dB	dBuV	dB/m	dB	cm	deg	1 10640.00	46.15	74.00	-27.85	56.12	37.78	10.94	58.69	-- -- Peak	2 15960.00	46.03	74.00	-27.97	53.11	39.59	12.70	59.37
	Limit	Read	Ant	Cable	Preamp	APos	TPos																																																																																				
Freq	Level	Line Margin	Level Factor	Loss Factor				Remark																																																																																			
MHz	dBuV/m	dBuV/m	dB	dBuV	dB/m	dB	cm	deg																																																																																			
1 10640.00	46.26	74.00	-27.74	56.23	37.78	10.94	58.69	-- -- Peak																																																																																			
2 15960.00	46.33	74.00	-27.67	53.41	39.59	12.70	59.37	-- -- Peak																																																																																			
	Limit	Read	Ant	Cable	Preamp	APos	TPos																																																																																				
Freq	Level	Line Margin	Level Factor	Loss Factor				Remark																																																																																			
MHz	dBuV/m	dBuV/m	dB	dBuV	dB/m	dB	cm	deg																																																																																			
1 10640.00	46.15	74.00	-27.85	56.12	37.78	10.94	58.69	-- -- Peak																																																																																			
2 15960.00	46.03	74.00	-27.97	53.11	39.59	12.70	59.37	-- -- Peak																																																																																			

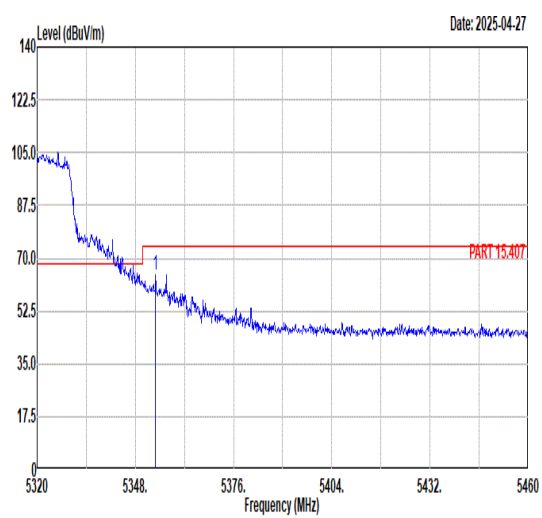
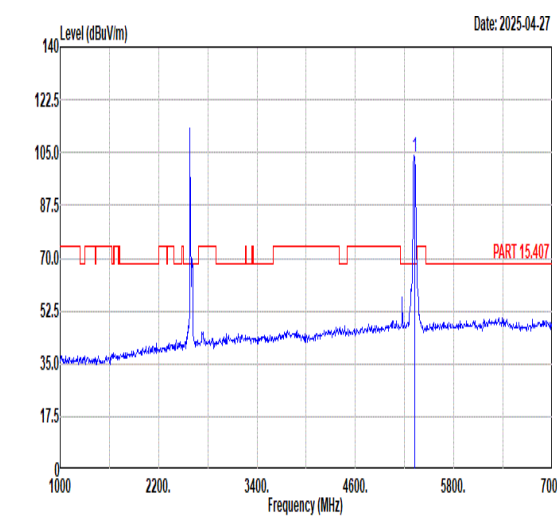
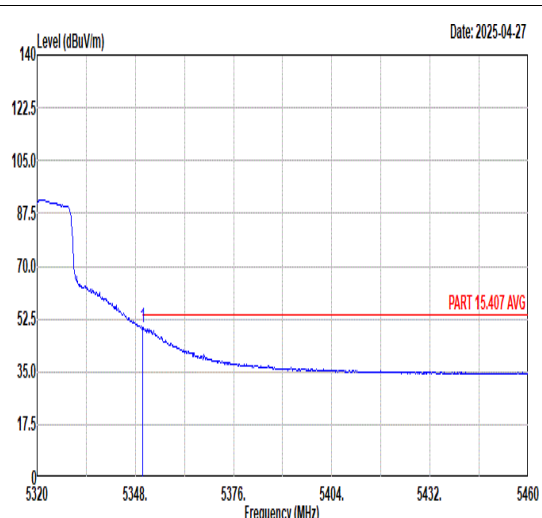
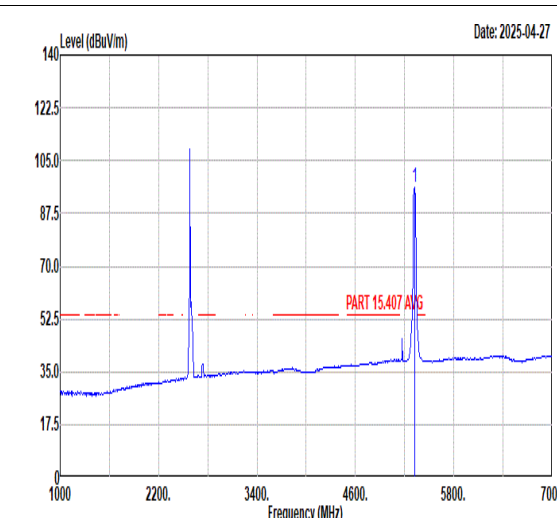

Mode	2																																																													
	Band Edge																																																													
	LTE Band 41 + 802.11ax HE20 + BT on + NFC on.																																																													
ANT	5																																																													
Pol.	Horizontal	Fundamental																																																												
Peak	 <p style="text-align: right;">Date: 2025-04-27</p> <table border="1"> <thead> <tr> <th>Limit Freq</th> <th>Limit Level</th> <th>Read Level</th> <th>Line Margin</th> <th>Ant Level</th> <th>Cable Loss</th> <th>Preamp Loss</th> <th>APos</th> <th>TPos</th> <th>Remark</th> </tr> <tr> <th>MHz</th> <th>dBuV/m</th> <th>dBuV/m</th> <th>dB</th> <th>dBuV</th> <th>dB/m</th> <th>dB</th> <th>cm</th> <th>deg</th> <th></th> </tr> </thead> <tbody> <tr> <td>1 5353.74</td> <td>64.56</td> <td>74.00</td> <td>-9.44</td> <td>54.77</td> <td>34.11</td> <td>8.34</td> <td>32.66</td> <td>106</td> <td>58 PEAK</td> </tr> </tbody> </table>	Limit Freq	Limit Level	Read Level	Line Margin	Ant Level	Cable Loss	Preamp Loss	APos	TPos	Remark	MHz	dBuV/m	dBuV/m	dB	dBuV	dB/m	dB	cm	deg		1 5353.74	64.56	74.00	-9.44	54.77	34.11	8.34	32.66	106	58 PEAK	 <p style="text-align: right;">Date: 2025-04-27</p> <table border="1"> <thead> <tr> <th>Limit Freq</th> <th>Limit Level</th> <th>Read Level</th> <th>Line Margin</th> <th>Ant Level</th> <th>Cable Loss</th> <th>Preamp Loss</th> <th>APos</th> <th>TPos</th> <th>Remark</th> </tr> <tr> <th>MHz</th> <th>dBuV/m</th> <th>dBuV/m</th> <th>dB</th> <th>dBuV</th> <th>dB/m</th> <th>dB</th> <th>cm</th> <th>deg</th> <th></th> </tr> </thead> <tbody> <tr> <td>1 5320.00</td> <td>103.80</td> <td>-----</td> <td>-----</td> <td>101.53</td> <td>30.64</td> <td>5.06</td> <td>33.43</td> <td>106</td> <td>58 PEAK</td> </tr> </tbody> </table>	Limit Freq	Limit Level	Read Level	Line Margin	Ant Level	Cable Loss	Preamp Loss	APos	TPos	Remark	MHz	dBuV/m	dBuV/m	dB	dBuV	dB/m	dB	cm	deg		1 5320.00	103.80	-----	-----	101.53	30.64	5.06	33.43	106	58 PEAK
	Limit Freq	Limit Level	Read Level	Line Margin	Ant Level	Cable Loss	Preamp Loss	APos	TPos	Remark																																																				
MHz	dBuV/m	dBuV/m	dB	dBuV	dB/m	dB	cm	deg																																																						
1 5353.74	64.56	74.00	-9.44	54.77	34.11	8.34	32.66	106	58 PEAK																																																					
Limit Freq	Limit Level	Read Level	Line Margin	Ant Level	Cable Loss	Preamp Loss	APos	TPos	Remark																																																					
MHz	dBuV/m	dBuV/m	dB	dBuV	dB/m	dB	cm	deg																																																						
1 5320.00	103.80	-----	-----	101.53	30.64	5.06	33.43	106	58 PEAK																																																					
Avg	 <p style="text-align: right;">Date: 2025-04-27</p> <table border="1"> <thead> <tr> <th>Limit Freq</th> <th>Limit Level</th> <th>Read Level</th> <th>Line Margin</th> <th>Ant Level</th> <th>Cable Loss</th> <th>Preamp Loss</th> <th>APos</th> <th>TPos</th> <th>Remark</th> </tr> <tr> <th>MHz</th> <th>dBuV/m</th> <th>dBuV/m</th> <th>dB</th> <th>dBuV</th> <th>dB/m</th> <th>dB</th> <th>cm</th> <th>deg</th> <th></th> </tr> </thead> <tbody> <tr> <td>1 5350.10</td> <td>49.71</td> <td>54.00</td> <td>-4.29</td> <td>39.93</td> <td>34.11</td> <td>8.33</td> <td>32.66</td> <td>106</td> <td>58 AVERAGE</td> </tr> </tbody> </table>	Limit Freq	Limit Level	Read Level	Line Margin	Ant Level	Cable Loss	Preamp Loss	APos	TPos	Remark	MHz	dBuV/m	dBuV/m	dB	dBuV	dB/m	dB	cm	deg		1 5350.10	49.71	54.00	-4.29	39.93	34.11	8.33	32.66	106	58 AVERAGE	 <p style="text-align: right;">Date: 2025-04-27</p> <table border="1"> <thead> <tr> <th>Limit Freq</th> <th>Limit Level</th> <th>Read Level</th> <th>Line Margin</th> <th>Ant Level</th> <th>Cable Loss</th> <th>Preamp Loss</th> <th>APos</th> <th>TPos</th> <th>Remark</th> </tr> <tr> <th>MHz</th> <th>dBuV/m</th> <th>dBuV/m</th> <th>dB</th> <th>dBuV</th> <th>dB/m</th> <th>dB</th> <th>cm</th> <th>deg</th> <th></th> </tr> </thead> <tbody> <tr> <td>1 5320.00</td> <td>95.90</td> <td>-----</td> <td>-----</td> <td>93.63</td> <td>30.64</td> <td>5.06</td> <td>33.43</td> <td>106</td> <td>58 AVERAGE</td> </tr> </tbody> </table>	Limit Freq	Limit Level	Read Level	Line Margin	Ant Level	Cable Loss	Preamp Loss	APos	TPos	Remark	MHz	dBuV/m	dBuV/m	dB	dBuV	dB/m	dB	cm	deg		1 5320.00	95.90	-----	-----	93.63	30.64	5.06	33.43	106	58 AVERAGE
Limit Freq	Limit Level	Read Level	Line Margin	Ant Level	Cable Loss	Preamp Loss	APos	TPos	Remark																																																					
MHz	dBuV/m	dBuV/m	dB	dBuV	dB/m	dB	cm	deg																																																						
1 5350.10	49.71	54.00	-4.29	39.93	34.11	8.33	32.66	106	58 AVERAGE																																																					
Limit Freq	Limit Level	Read Level	Line Margin	Ant Level	Cable Loss	Preamp Loss	APos	TPos	Remark																																																					
MHz	dBuV/m	dBuV/m	dB	dBuV	dB/m	dB	cm	deg																																																						
1 5320.00	95.90	-----	-----	93.63	30.64	5.06	33.43	106	58 AVERAGE																																																					

Remark: All signals exceeding the limit are fundamental frequency signals and can be ignored.



		2																																																																	
<b>Mode</b>	<b>Band Edge</b>																																																																		
	<b>LTE Band 41 + 802.11ax HE20 + BT on + NFC on.</b>																																																																		
<b>ANT</b>	5																																																																		
<b>Pol.</b>	<b>Vertical</b>	<b>Fundamental</b>																																																																	
<b>Peak</b>	<p style="text-align: right;">Date: 2025-04-27</p> <table border="1"> <thead> <tr> <th>Limit</th> <th>Read</th> <th>Ant</th> <th>Cable</th> <th>Preamp</th> <th>APos</th> <th>TPos</th> <th>Remark</th> </tr> <tr> <th>Freq</th> <th>Level</th> <th>Line Margin</th> <th>Level</th> <th>Factor</th> <th>Loss Factor</th> <th></th> <th></th> </tr> <tr> <th>MHz</th> <th>dBuV/m</th> <th>dBuV/m</th> <th>dB</th> <th>dBuV</th> <th>dB/m</th> <th>dB</th> <th>cm deg</th> </tr> </thead> <tbody> <tr> <td>1 5350.10</td> <td>55.49</td> <td>74.00</td> <td>-18.51</td> <td>45.71</td> <td>34.11</td> <td>8.33</td> <td>32.66 103 257 PEAK</td> </tr> </tbody> </table>	Limit	Read	Ant	Cable	Preamp	APos	TPos	Remark	Freq	Level	Line Margin	Level	Factor	Loss Factor			MHz	dBuV/m	dBuV/m	dB	dBuV	dB/m	dB	cm deg	1 5350.10	55.49	74.00	-18.51	45.71	34.11	8.33	32.66 103 257 PEAK	<p style="text-align: right;">Date: 2025-04-27</p> <table border="1"> <thead> <tr> <th>Limit</th> <th>Read</th> <th>Ant</th> <th>Cable</th> <th>Preamp</th> <th>APos</th> <th>TPos</th> <th>Remark</th> </tr> <tr> <th>Freq</th> <th>Level</th> <th>Line Margin</th> <th>Level</th> <th>Factor</th> <th>Loss Factor</th> <th></th> <th></th> </tr> <tr> <th>MHz</th> <th>dBuV/m</th> <th>dBuV/m</th> <th>dB</th> <th>dBuV</th> <th>dB/m</th> <th>dB</th> <th>cm deg</th> </tr> </thead> <tbody> <tr> <td>1 5320.00</td> <td>97.58</td> <td>-----</td> <td>-----</td> <td>95.31</td> <td>30.64</td> <td>5.06</td> <td>33.43 103 257 PEAK</td> </tr> </tbody> </table>		Limit	Read	Ant	Cable	Preamp	APos	TPos	Remark	Freq	Level	Line Margin	Level	Factor	Loss Factor			MHz	dBuV/m	dBuV/m	dB	dBuV	dB/m	dB	cm deg	1 5320.00	97.58	-----	-----	95.31	30.64	5.06	33.43 103 257 PEAK
	Limit	Read	Ant	Cable	Preamp	APos	TPos	Remark																																																											
Freq	Level	Line Margin	Level	Factor	Loss Factor																																																														
MHz	dBuV/m	dBuV/m	dB	dBuV	dB/m	dB	cm deg																																																												
1 5350.10	55.49	74.00	-18.51	45.71	34.11	8.33	32.66 103 257 PEAK																																																												
Limit	Read	Ant	Cable	Preamp	APos	TPos	Remark																																																												
Freq	Level	Line Margin	Level	Factor	Loss Factor																																																														
MHz	dBuV/m	dBuV/m	dB	dBuV	dB/m	dB	cm deg																																																												
1 5320.00	97.58	-----	-----	95.31	30.64	5.06	33.43 103 257 PEAK																																																												
<b>Avg</b>	<p style="text-align: right;">Date: 2025-04-27</p> <table border="1"> <thead> <tr> <th>Limit</th> <th>Read</th> <th>Ant</th> <th>Cable</th> <th>Preamp</th> <th>APos</th> <th>TPos</th> <th>Remark</th> </tr> <tr> <th>Freq</th> <th>Level</th> <th>Line Margin</th> <th>Level</th> <th>Factor</th> <th>Loss Factor</th> <th></th> <th></th> </tr> <tr> <th>MHz</th> <th>dBuV/m</th> <th>dBuV/m</th> <th>dB</th> <th>dBuV</th> <th>dB/m</th> <th>dB</th> <th>cm deg</th> </tr> </thead> <tbody> <tr> <td>1 5350.10</td> <td>46.21</td> <td>54.00</td> <td>-7.79</td> <td>36.43</td> <td>34.11</td> <td>8.33</td> <td>32.66 103 257 AVERAGE</td> </tr> </tbody> </table>	Limit	Read	Ant	Cable	Preamp	APos	TPos	Remark	Freq	Level	Line Margin	Level	Factor	Loss Factor			MHz	dBuV/m	dBuV/m	dB	dBuV	dB/m	dB	cm deg	1 5350.10	46.21	54.00	-7.79	36.43	34.11	8.33	32.66 103 257 AVERAGE	<p style="text-align: right;">Date: 2025-04-27</p> <table border="1"> <thead> <tr> <th>Limit</th> <th>Read</th> <th>Ant</th> <th>Cable</th> <th>Preamp</th> <th>APos</th> <th>TPos</th> <th>Remark</th> </tr> <tr> <th>Freq</th> <th>Level</th> <th>Line Margin</th> <th>Level</th> <th>Factor</th> <th>Loss Factor</th> <th></th> <th></th> </tr> <tr> <th>MHz</th> <th>dBuV/m</th> <th>dBuV/m</th> <th>dB</th> <th>dBuV</th> <th>dB/m</th> <th>dB</th> <th>cm deg</th> </tr> </thead> <tbody> <tr> <td>1 5320.00</td> <td>89.80</td> <td>-----</td> <td>-----</td> <td>87.53</td> <td>30.64</td> <td>5.06</td> <td>33.43 103 257 AVERAGE</td> </tr> </tbody> </table>		Limit	Read	Ant	Cable	Preamp	APos	TPos	Remark	Freq	Level	Line Margin	Level	Factor	Loss Factor			MHz	dBuV/m	dBuV/m	dB	dBuV	dB/m	dB	cm deg	1 5320.00	89.80	-----	-----	87.53	30.64	5.06	33.43 103 257 AVERAGE
	Limit	Read	Ant	Cable	Preamp	APos	TPos	Remark																																																											
Freq	Level	Line Margin	Level	Factor	Loss Factor																																																														
MHz	dBuV/m	dBuV/m	dB	dBuV	dB/m	dB	cm deg																																																												
1 5350.10	46.21	54.00	-7.79	36.43	34.11	8.33	32.66 103 257 AVERAGE																																																												
Limit	Read	Ant	Cable	Preamp	APos	TPos	Remark																																																												
Freq	Level	Line Margin	Level	Factor	Loss Factor																																																														
MHz	dBuV/m	dBuV/m	dB	dBuV	dB/m	dB	cm deg																																																												
1 5320.00	89.80	-----	-----	87.53	30.64	5.06	33.43 103 257 AVERAGE																																																												



Mode	2																																																																																																
	Harmonic																																																																																																
	LTE Band 41 + 802.11ax HE20 + BT on + NFC on.																																																																																																
ANT	5																																																																																																
Pol.	Horizontal	Vertical																																																																																															
Peak Avg	<p>Date: 2025-04-27</p>	<p>Date: 2025-04-27</p>																																																																																															
	<table border="1"> <thead> <tr> <th>Limit</th> <th>Read</th> <th>Ant</th> <th>Cable</th> <th>Preamp</th> <th>APos</th> <th>TPos</th> <th>Remark</th> </tr> <tr> <th>Freq</th> <th>Level</th> <th>Line Margin</th> <th>Level</th> <th>Factor</th> <th>Loss Factor</th> <th></th> <th></th> </tr> <tr> <th>MHz</th> <th>dBuV/m</th> <th>dBuV/m</th> <th>dB</th> <th>dBuV</th> <th>dB/m</th> <th>dB</th> <th>dB</th> </tr> </thead> <tbody> <tr> <td>1</td> <td>10640.00</td> <td>47.57</td> <td>74.00</td> <td>-26.43</td> <td>57.54</td> <td>37.78</td> <td>10.94</td> <td>58.69</td> <td>--</td> <td>--</td> <td>Peak</td> </tr> <tr> <td>2</td> <td>15960.00</td> <td>45.19</td> <td>74.00</td> <td>-28.81</td> <td>52.27</td> <td>39.59</td> <td>12.70</td> <td>59.37</td> <td>--</td> <td>--</td> <td>Peak</td> </tr> </tbody> </table>	Limit	Read	Ant	Cable	Preamp	APos	TPos	Remark	Freq	Level	Line Margin	Level	Factor	Loss Factor			MHz	dBuV/m	dBuV/m	dB	dBuV	dB/m	dB	dB	1	10640.00	47.57	74.00	-26.43	57.54	37.78	10.94	58.69	--	--	Peak	2	15960.00	45.19	74.00	-28.81	52.27	39.59	12.70	59.37	--	--	Peak	<table border="1"> <thead> <tr> <th>Limit</th> <th>Read</th> <th>Ant</th> <th>Cable</th> <th>Preamp</th> <th>APos</th> <th>TPos</th> <th>Remark</th> </tr> <tr> <th>Freq</th> <th>Level</th> <th>Line Margin</th> <th>Level</th> <th>Factor</th> <th>Loss Factor</th> <th></th> <th></th> </tr> <tr> <th>MHz</th> <th>dBuV/m</th> <th>dBuV/m</th> <th>dB</th> <th>dBuV</th> <th>dB/m</th> <th>dB</th> <th>dB</th> </tr> </thead> <tbody> <tr> <td>1</td> <td>10640.00</td> <td>46.77</td> <td>74.00</td> <td>-27.23</td> <td>56.74</td> <td>37.78</td> <td>10.94</td> <td>58.69</td> <td>--</td> <td>--</td> <td>Peak</td> </tr> <tr> <td>2</td> <td>15960.00</td> <td>45.21</td> <td>74.00</td> <td>-28.79</td> <td>52.29</td> <td>39.59</td> <td>12.70</td> <td>59.37</td> <td>--</td> <td>--</td> <td>Peak</td> </tr> </tbody> </table>	Limit	Read	Ant	Cable	Preamp	APos	TPos	Remark	Freq	Level	Line Margin	Level	Factor	Loss Factor			MHz	dBuV/m	dBuV/m	dB	dBuV	dB/m	dB	dB	1	10640.00	46.77	74.00	-27.23	56.74	37.78	10.94	58.69	--	--	Peak	2	15960.00	45.21	74.00	-28.79	52.29	39.59	12.70	59.37	--	--
Limit	Read	Ant	Cable	Preamp	APos	TPos	Remark																																																																																										
Freq	Level	Line Margin	Level	Factor	Loss Factor																																																																																												
MHz	dBuV/m	dBuV/m	dB	dBuV	dB/m	dB	dB																																																																																										
1	10640.00	47.57	74.00	-26.43	57.54	37.78	10.94	58.69	--	--	Peak																																																																																						
2	15960.00	45.19	74.00	-28.81	52.27	39.59	12.70	59.37	--	--	Peak																																																																																						
Limit	Read	Ant	Cable	Preamp	APos	TPos	Remark																																																																																										
Freq	Level	Line Margin	Level	Factor	Loss Factor																																																																																												
MHz	dBuV/m	dBuV/m	dB	dBuV	dB/m	dB	dB																																																																																										
1	10640.00	46.77	74.00	-27.23	56.74	37.78	10.94	58.69	--	--	Peak																																																																																						
2	15960.00	45.21	74.00	-28.79	52.29	39.59	12.70	59.37	--	--	Peak																																																																																						

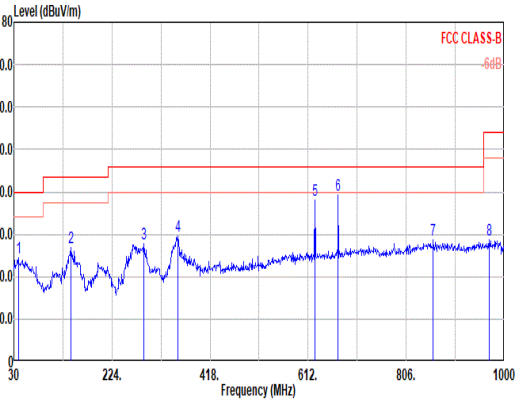
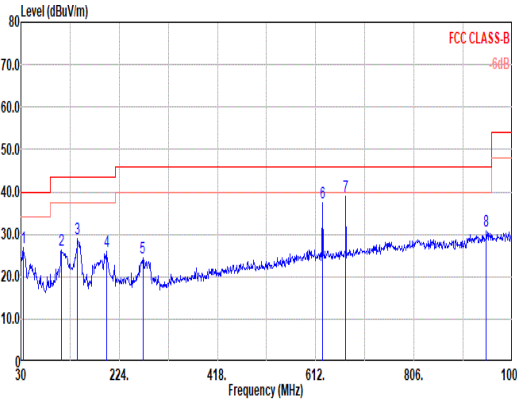

Mode	3																																																																																																																																																																																																																									
	LF																																																																																																																																																																																																																									
	LTE Band 71 + 802.11ax HE20 + BT on + NFC on.																																																																																																																																																																																																																									
ANT	5																																																																																																																																																																																																																									
Pol.	Horizontal	Vertical																																																																																																																																																																																																																								
Peak Avg	 <table border="1"> <thead> <tr> <th></th> <th>Limit</th> <th>Read</th> <th>Ant</th> <th>Cable</th> <th>Preamp</th> <th>APos</th> <th>TPos</th> <th>Remark</th> </tr> <tr> <th>Freq</th> <th>Level</th> <th>Line</th> <th>Margin</th> <th>Level</th> <th>Factor</th> <th>Loss</th> <th>Factor</th> <th></th> </tr> <tr> <th>MHz</th> <th>dBuV/m</th> <th>dBuV/m</th> <th>dB</th> <th>dBuV</th> <th>dB/m</th> <th>dB</th> <th>dB</th> <th>cm</th> <th>deg</th> </tr> </thead> <tbody> <tr><td>1</td><td>38.73</td><td>24.31</td><td>40.00</td><td>-15.69</td><td>39.43</td><td>19.16</td><td>0.62</td><td>34.90</td><td>-- -- Peak</td></tr> <tr><td>2</td><td>142.52</td><td>26.81</td><td>43.50</td><td>-16.69</td><td>41.93</td><td>18.35</td><td>1.25</td><td>34.72</td><td>-- -- Peak</td></tr> <tr><td>3</td><td>287.05</td><td>27.91</td><td>46.00</td><td>-18.09</td><td>42.06</td><td>18.72</td><td>1.76</td><td>34.63</td><td>-- -- Peak</td></tr> <tr><td>4</td><td>353.98</td><td>29.69</td><td>46.00</td><td>-16.31</td><td>42.02</td><td>20.31</td><td>1.95</td><td>34.59</td><td>-- -- Peak</td></tr> <tr><td>5</td><td>625.50</td><td>38.03</td><td></td><td></td><td>43.75</td><td>26.17</td><td>2.66</td><td>34.55</td><td>-- -- Peak</td></tr> <tr><td>6</td><td>671.50</td><td>39.23</td><td></td><td></td><td>44.32</td><td>26.62</td><td>2.75</td><td>34.46</td><td>-- -- Peak</td></tr> <tr><td>7</td><td>859.35</td><td>28.78</td><td>46.00</td><td>-17.22</td><td>31.20</td><td>28.77</td><td>3.11</td><td>34.30</td><td>-- -- Peak</td></tr> <tr><td>8</td><td>970.90</td><td>28.79</td><td>54.00</td><td>-25.21</td><td>29.87</td><td>29.88</td><td>3.30</td><td>34.26</td><td>-- -- Peak</td></tr> </tbody> </table>		Limit	Read	Ant	Cable	Preamp	APos	TPos	Remark	Freq	Level	Line	Margin	Level	Factor	Loss	Factor		MHz	dBuV/m	dBuV/m	dB	dBuV	dB/m	dB	dB	cm	deg	1	38.73	24.31	40.00	-15.69	39.43	19.16	0.62	34.90	-- -- Peak	2	142.52	26.81	43.50	-16.69	41.93	18.35	1.25	34.72	-- -- Peak	3	287.05	27.91	46.00	-18.09	42.06	18.72	1.76	34.63	-- -- Peak	4	353.98	29.69	46.00	-16.31	42.02	20.31	1.95	34.59	-- -- Peak	5	625.50	38.03			43.75	26.17	2.66	34.55	-- -- Peak	6	671.50	39.23			44.32	26.62	2.75	34.46	-- -- Peak	7	859.35	28.78	46.00	-17.22	31.20	28.77	3.11	34.30	-- -- Peak	8	970.90	28.79	54.00	-25.21	29.87	29.88	3.30	34.26	-- -- Peak	 <table border="1"> <thead> <tr> <th></th> <th>Limit</th> <th>Read</th> <th>Ant</th> <th>Cable</th> <th>Preamp</th> <th>APos</th> <th>TPos</th> <th>Remark</th> </tr> <tr> <th>Freq</th> <th>Level</th> <th>Line</th> <th>Margin</th> <th>Level</th> <th>Factor</th> <th>Loss</th> <th>Factor</th> <th></th> </tr> <tr> <th>MHz</th> <th>dBuV/m</th> <th>dBuV/m</th> <th>dB</th> <th>dBuV</th> <th>dB/m</th> <th>dB</th> <th>dB</th> <th>cm</th> <th>deg</th> </tr> </thead> <tbody> <tr><td>1</td><td>34.85</td><td>26.73</td><td>40.00</td><td>-13.27</td><td>42.37</td><td>18.68</td><td>0.58</td><td>34.90</td><td>-- -- Peak</td></tr> <tr><td>2</td><td>109.54</td><td>26.35</td><td>43.50</td><td>-17.15</td><td>44.34</td><td>15.68</td><td>1.11</td><td>34.78</td><td>-- -- Peak</td></tr> <tr><td>3</td><td>141.55</td><td>29.03</td><td>43.50</td><td>-14.47</td><td>44.23</td><td>18.27</td><td>1.25</td><td>34.72</td><td>-- -- Peak</td></tr> <tr><td>4</td><td>198.78</td><td>25.84</td><td>43.50</td><td>-17.66</td><td>43.01</td><td>16.05</td><td>1.48</td><td>34.70</td><td>-- -- Peak</td></tr> <tr><td>5</td><td>270.56</td><td>24.31</td><td>46.00</td><td>-21.69</td><td>39.05</td><td>18.21</td><td>1.71</td><td>34.66</td><td>-- -- Peak</td></tr> <tr><td>6</td><td>625.50</td><td>37.44</td><td></td><td></td><td>43.16</td><td>26.17</td><td>2.66</td><td>34.55</td><td>-- -- Peak</td></tr> <tr><td>7</td><td>671.50</td><td>38.82</td><td></td><td></td><td>43.91</td><td>26.62</td><td>2.75</td><td>34.46</td><td>-- -- Peak</td></tr> <tr><td>8</td><td>948.59</td><td>30.69</td><td>46.00</td><td>-15.31</td><td>31.99</td><td>29.74</td><td>3.26</td><td>34.30</td><td>-- -- Peak</td></tr> </tbody> </table>		Limit	Read	Ant	Cable	Preamp	APos	TPos	Remark	Freq	Level	Line	Margin	Level	Factor	Loss	Factor		MHz	dBuV/m	dBuV/m	dB	dBuV	dB/m	dB	dB	cm	deg	1	34.85	26.73	40.00	-13.27	42.37	18.68	0.58	34.90	-- -- Peak	2	109.54	26.35	43.50	-17.15	44.34	15.68	1.11	34.78	-- -- Peak	3	141.55	29.03	43.50	-14.47	44.23	18.27	1.25	34.72	-- -- Peak	4	198.78	25.84	43.50	-17.66	43.01	16.05	1.48	34.70	-- -- Peak	5	270.56	24.31	46.00	-21.69	39.05	18.21	1.71	34.66	-- -- Peak	6	625.50	37.44			43.16	26.17	2.66	34.55	-- -- Peak	7	671.50	38.82			43.91	26.62	2.75	34.46	-- -- Peak	8	948.59	30.69	46.00	-15.31	31.99	29.74	3.26	34.30	-- -- Peak
		Limit	Read	Ant	Cable	Preamp	APos	TPos	Remark																																																																																																																																																																																																																	
Freq	Level	Line	Margin	Level	Factor	Loss	Factor																																																																																																																																																																																																																			
MHz	dBuV/m	dBuV/m	dB	dBuV	dB/m	dB	dB	cm	deg																																																																																																																																																																																																																	
1	38.73	24.31	40.00	-15.69	39.43	19.16	0.62	34.90	-- -- Peak																																																																																																																																																																																																																	
2	142.52	26.81	43.50	-16.69	41.93	18.35	1.25	34.72	-- -- Peak																																																																																																																																																																																																																	
3	287.05	27.91	46.00	-18.09	42.06	18.72	1.76	34.63	-- -- Peak																																																																																																																																																																																																																	
4	353.98	29.69	46.00	-16.31	42.02	20.31	1.95	34.59	-- -- Peak																																																																																																																																																																																																																	
5	625.50	38.03			43.75	26.17	2.66	34.55	-- -- Peak																																																																																																																																																																																																																	
6	671.50	39.23			44.32	26.62	2.75	34.46	-- -- Peak																																																																																																																																																																																																																	
7	859.35	28.78	46.00	-17.22	31.20	28.77	3.11	34.30	-- -- Peak																																																																																																																																																																																																																	
8	970.90	28.79	54.00	-25.21	29.87	29.88	3.30	34.26	-- -- Peak																																																																																																																																																																																																																	
	Limit	Read	Ant	Cable	Preamp	APos	TPos	Remark																																																																																																																																																																																																																		
Freq	Level	Line	Margin	Level	Factor	Loss	Factor																																																																																																																																																																																																																			
MHz	dBuV/m	dBuV/m	dB	dBuV	dB/m	dB	dB	cm	deg																																																																																																																																																																																																																	
1	34.85	26.73	40.00	-13.27	42.37	18.68	0.58	34.90	-- -- Peak																																																																																																																																																																																																																	
2	109.54	26.35	43.50	-17.15	44.34	15.68	1.11	34.78	-- -- Peak																																																																																																																																																																																																																	
3	141.55	29.03	43.50	-14.47	44.23	18.27	1.25	34.72	-- -- Peak																																																																																																																																																																																																																	
4	198.78	25.84	43.50	-17.66	43.01	16.05	1.48	34.70	-- -- Peak																																																																																																																																																																																																																	
5	270.56	24.31	46.00	-21.69	39.05	18.21	1.71	34.66	-- -- Peak																																																																																																																																																																																																																	
6	625.50	37.44			43.16	26.17	2.66	34.55	-- -- Peak																																																																																																																																																																																																																	
7	671.50	38.82			43.91	26.62	2.75	34.46	-- -- Peak																																																																																																																																																																																																																	
8	948.59	30.69	46.00	-15.31	31.99	29.74	3.26	34.30	-- -- Peak																																																																																																																																																																																																																	

Remark: 625.5MHz & 671.5MHz are WWAN fundamental frequency signals and can be ignored



## **Appendix C. Reference Report**



# FCC RF Test Report

**APPLICANT** : Motorola Mobility LLC  
**EQUIPMENT** : Mobile Cellular Phone  
**BRAND NAME** : Motorola  
**MODEL NAME** : XT2527-1  
**FCC ID** : IHDT56AV5  
**STANDARD** : 47 CFR Part 22(H), 24(E), 27(L)  
**CLASSIFICATION** : PCS Licensed Transmitter Held to Ear (PCE)  
**TEST DATE(S)** : Mar. 29, 2025 ~ Apr. 03, 2025

We, Sporton International Inc. (Kunshan), would like to declare that the tested sample has been evaluated in accordance with the procedures given in ANSI C63.26-2015 and shown compliance with the applicable technical standards.

This report contains data that were produced under subcontract by Sporton International Inc. (Shenzhen)

The test results in this report apply exclusively to the tested model / sample. Without written approval of Sporton International Inc. (Kunshan), the test report shall not be reproduced except in full.

Jason Jia



Approved by: Jason Jia

**Sporton International Inc. (Kunshan)**

**No. 1098, Pengxi North Road, Kunshan Economic Development Zone Jiangsu Province 215300  
People's Republic of China**



# TABLE OF CONTENTS

**REVISION HISTORY..... 3**

**SUMMARY OF TEST RESULT ..... 4**

**1 GENERAL DESCRIPTION ..... 5**

    1.1 Applicant..... 5

    1.2 Manufacturer ..... 5

    1.3 Product Feature of Equipment Under Test ..... 5

    1.4 Product Specification of Equipment Under Test ..... 5

    1.5 Modification of EUT ..... 6

    1.6 Maximum ERP/EIRP, and Emission Designator ..... 6

    1.7 Testing Location ..... 7

    1.8 Test Software ..... 7

    1.9 Applicable Standards ..... 8

    1.10 Specification of Accessory ..... 8

**2 TEST CONFIGURATION OF EQUIPMENT UNDER TEST ..... 9**

    2.1 Test Mode..... 9

    2.2 Connection Diagram of Test System ..... 10

    2.3 Support Unit used in test configuration ..... 10

    2.4 Measurement Results Explanation Example ..... 11

    2.5 Frequency List of Low/Middle/High Channels..... 11

**3 CONDUCTED TEST RESULT..... 12**

    3.1 Measuring Instruments..... 12

    3.2 Test Setup ..... 12

    3.3 Test Result of Conducted Test..... 12

    3.4 Conducted Output Power and ERP/EIRP ..... 13

    3.5 Peak-to-Average Ratio ..... 14

    3.6 99% Occupied Bandwidth and 26dB Bandwidth Measurement..... 15

    3.7 Conducted Band Edge ..... 16

    3.8 Conducted Spurious Emission ..... 17

    3.9 Frequency Stability..... 18

**4 RADIATED TEST ITEMS ..... 19**

    4.1 Measuring Instruments..... 19

    4.2 Test Setup ..... 19

    4.3 Test Result of Radiated Test..... 20

    4.4 Field Strength of Spurious Radiation Measurement ..... 21

**5 LIST OF MEASURING EQUIPMENT ..... 22**

**6 MEASUREMENT UNCERTAINTY ..... 23**

**APPENDIX A. TEST RESULTS OF CONDUCTED TEST**

**APPENDIX B. TEST RESULTS OF RADIATED TEST**

**APPENDIX C. TEST SETUP PHOTOGRAPHS**





## SUMMARY OF TEST RESULT

Report Section	FCC Rule	Description	Limit	Result	Remark
3.4	§2.1046	Conducted Output Power	-	Report Only	-
	§22.913(a)(5)	Effective Radiated Power	< 7 Watts	PASS	-
	§24.232(c)	Equivalent Isotropic Radiated Power	< 2 Watts	PASS	-
	§27.50(d)(4)	Equivalent Isotropic Radiated Power	< 1 Watts	PASS	-
3.5	§24.232(d)	Peak-to-Average Ratio	< 13 dB	PASS	-
3.6	§2.1049	Occupied Bandwidth	Reporting Only	PASS	-
3.7	§2.1051 §22.917(a) §24.238(a) §27.53(h)	Band Edge Measurement	< 43+10log10(P[Watts])	PASS	-
3.8	§2.1051 §22.917(a) §24.238(a) §27.53(h)	Conducted Emission	< 43+10log10(P[Watts])	PASS	-
3.9	§2.1055 §22.355	Frequency Stability for Temperature & Voltage	< 2.5 ppm for Part 22	PASS	-
	§2.1055 §24.235 §27.54		Within Authorized Band		
4.4	§2.1053; §22.917(a); §24.238(a); §27.53(h)	Field Strength of Spurious Radiation	< 43+10log10(P[Watts])	PASS	Under limit 21.48 dB at 2509.20 MHz

**Conformity Assessment Condition:**

1. The test results (PASS/FAIL) with all measurement uncertainty excluded are presented against the regulation limits or in accordance with the requirements stipulated by the applicant/manufacturer who shall bear all the risks of non-compliance that may potentially occur if measurement uncertainty is taken into account.
2. The measurement uncertainty please refer to each test result in the section "Measurement Uncertainty"

**Disclaimer:**

The product specifications of the EUT presented in the test report that may affect the test assessments are declared by the manufacturer who shall take full responsibility for the authenticity.



# 1 General Description

## 1.1 Applicant

Motorola Mobility LLC  
222 W,Merchandise Mart Plaza, Chicago IL 60654 USA

## 1.2 Manufacturer

Motorola Mobility LLC  
222 W,Merchandise Mart Plaza, Chicago IL 60654 USA

## 1.3 Product Feature of Equipment Under Test

Product Feature	
Equipment	Mobile Cellular Phone
Brand Name	Motorola
Model Name	XT2527-1
FCC ID	IHDT56AV5
IMEI Code	Conducted: 358887330041698/358887330041706 Radiation: 358887330039734/358887330039742
HW Version	DVT2
SW Version	V2VN35.50
EUT Stage	Identical Prototype

Remark: The above EUT's information was declared by manufacturer. Please refer to the specifications or user's manual for more detailed description.

## 1.4 Product Specification of Equipment Under Test

Standards-related Product Specification	
Tx Frequency	<b>GSM/GPRS/EDGE:</b> 850: 824 MHz ~ 849 MHz 1900: 1850MHz ~ 1910MHz <b>WCDMA:</b> Band V: 824 MHz ~ 849 MHz Band II: 1850 MHz ~ 1910 MHz Band IV: 1710 MHz ~ 1755 MHz
Rx Frequency	<b>GSM/GPRS/EDGE:</b> 850: 869 MHz ~ 894 MHz 1900: 1930 MHz ~ 1990 MHz <b>WCDMA:</b> Band V: 869 MHz ~ 894 MHz Band II: 1930 MHz ~ 1990 MHz Band IV: 2110 MHz ~ 2155 MHz



<b>Maximum Output Power to Antenna</b>	<b>GSM/GPRS/EDGE:</b> 850<ANT0>: 31.76 dBm 1900<ANT1>: 28.52 dBm <b>WCDMA:</b> Band V<ANT0>: 22.58 dBm Band II<ANT1>: 22.70 dBm Band IV<ANT1>: 22.72 dBm
<b>Antenna Gain</b>	Cellular Band: -5.4 dBi PCS Band: -3.1 dBi AWS Band: -3.6 dBi
<b>Type of Modulation</b>	GSM: GMSK GPRS: GMSK EDGE: GMSK / 8PSK WCDMA: BPSK (Uplink) HSDPA: QPSK (Uplink) HSUPA: QPSK (Uplink) HSPA+ : 16QAM (Uplink)

### 1.5 Modification of EUT

No modifications are made to the EUT during all test items.

### 1.6 Maximum ERP/EIRP, and Emission Designator

FCC Rule	Frequency Band	Frequency Range (MHz)	Type of Modulation	Maximum ERP/EIRP (W)	Emission Designator
Part 22	GSM850 (GSM)	824.2 ~ 848.8	GMSK	0.2636	245KGXW
Part 22	GSM850 (EDGE)	824.2 ~ 848.8	8PSK	0.0733	249KG7W
Part 22	WCDMA Band V	826.4 ~ 846.6	BPSK	0.0318	4M15F9W
Part 24	GSM1900 (GSM)	1850.2 ~ 1909.8	GMSK	0.3483	245KGXW
Part 24	GSM1900 (EDGE)	1850.2 ~ 1909.8	8PSK	0.1030	256KG7W
Part 24	WCDMA Band II	1852.4 ~ 1907.6	BPSK	0.0912	4M15F9W
Part 27	WCDMA Band IV	1712.4 ~ 1752.6	BPSK	0.0817	4M15F9W



### 1.7 Testing Location

Sporton International Inc. (Kunshan) is accredited to ISO/IEC 17025:2017 by American Association for Laboratory Accreditation with Certificate Number 5145.02.

<b>Test Firm</b>	Sporton International Inc. (Kunshan)		
<b>Test Site Location</b>	No. 1098, Pengxi North Road, Kunshan Economic Development Zone Jiangsu Province 215300 People’s Republic of China TEL : +86-512-57900158		
<b>Test Site No.</b>	<b>Sporton Site No.</b>	<b>FCC Designation No.</b>	<b>FCC Test Firm Registration No.</b>
	TH01-KS	CN1257	314309

Sporton International Inc. (ShenZhen) is accredited to ISO/IEC 17025:2017 by American Association for Laboratory Accreditation with Certificate Number 5145.01.

<b>Test Firm</b>	Sporton International Inc. (ShenZhen)		
<b>Test Site Location</b>	101, 1st Floor, Block B, Building 1, No. 2, Tengfeng 4th Road, Fenghuang Community, Fuyong Street, Baoan District, Shenzhen City, Guangdong Province 518103 People’s Republic of China TEL: +86-755-86066985		
<b>Test Site No.</b>	<b>Sporton Site No.</b>	<b>FCC Designation No.</b>	<b>FCC Test Firm Registration No.</b>
	03CH02-SZ	CN1256	421272

Test data subcontracted: Radiated Spurious Emission test case in section 4.4 of this report.

### 1.8 Test Software

Item	Site	Manufacturer	Name	Version
1.	TH01-KS	SPORTON	FCC LTE_Ver2.0 Auto_china_2105 03	2.0
2.	03CH02-SZ	AUDIX	E3	6.2009-8-24a



### 1.9 Applicable Standards

According to the specifications of the manufacturer, the EUT must comply with the requirements of the following standards:

- 47 CFR Part 22(H), 24(E), 27(L)
- ANSI C63.26-2015
- FCC KDB 971168 D01 Power Meas. License Digital Systems v03r01
- FCC KDB 412172 D01 Determining ERP and EIRP v01r01

**Remark:**

1. All test items were verified and recorded according to the standards and without any deviation during the test.
2. This EUT has also been tested and complied with the requirements of FCC Part 15, Subpart B, recorded in a separate test report.

### 1.10 Specification of Accessory

Specification of Accessory				
AC Adapter 1(US)	Brand Name	Motorola(Salcomp)	Model Name	MC-331L
AC Adapter 1(EU)	Brand Name	Motorola(Salcomp)	Model Name	MC-332L
AC Adapter 1(UK)	Brand Name	Motorola(Salcomp)	Model Name	MC-333L
AC Adapter 1(AU)	Brand Name	Motorola(Salcomp)	Model Name	MC-335L
AC Adapter 1(AR)	Brand Name	Motorola(Salcomp)	Model Name	MC-336L
AC Adapter 1(BR)	Brand Name	Motorola(Salcomp)	Model Name	MC-337L
AC Adapter 2(US)	Brand Name	Motorola(Chenyang)	Model Name	MC-331L
AC Adapter 2(EU)	Brand Name	Motorola(Chenyang)	Model Name	MC-332L
AC Adapter 2(UK)	Brand Name	Motorola(Chenyang)	Model Name	MC-333L
AC Adapter 2(AR)	Brand Name	Motorola(Chenyang)	Model Name	MC-336L
AC Adapter 2(BR)	Brand Name	Motorola(Chenyang)	Model Name	MC-337L
Battery 1	Brand Name	Motorola(NVT)	Model Name	RA52
Battery 2	Brand Name	Motorola(SUNWODA)	Model Name	RA52
USB Cable 1	Brand Name	Motorola(Washin)	Model Name	HX-ZN-34
USB Cable 2	Brand Name	Motorola(Juwei)	Model Name	JWUB1928-ZN01H
Wireless Earphones	Brand Name	Motorola	Model Name	XT2443-1



## 2 Test Configuration of Equipment Under Test

### 2.1 Test Mode

Antenna port conducted and radiated test items were performed according to KDB 971168 D01 Power Meas. License Digital Systems v03r01 with maximum output power.

Radiated measurements were performed with rotating EUT in different three orthogonal test planes to find the maximum emission.

Radiated emissions were investigated as following frequency range:

1. 30 MHz to 9000 MHz for GSM850 and WCDMA Band V.
2. 30 MHz to 18000 MHz for WCDMA Band IV.
3. 30 MHz to 19100 MHz for GSM1900 and WCDMA Band II.

All modes and data rates and positions were investigated.

Test modes are chosen to be reported as the worst case configuration below:

Test Modes		
Band	Radiated TCs	Conducted TCs
GSM 850	<ul style="list-style-type: none"> <li>■ GSM Link</li> <li>■ EDGE 1 Tx slots Link</li> </ul>	<ul style="list-style-type: none"> <li>■ GSM Link</li> <li>■ EDGE 1 Tx slots Link</li> </ul>
GSM 1900	<ul style="list-style-type: none"> <li>■ GSM Link</li> <li>■ EDGE 1 Tx slots Link</li> </ul>	<ul style="list-style-type: none"> <li>■ GSM Link</li> <li>■ EDGE 1 Tx slots Link</li> </ul>
WCDMA Band V	<ul style="list-style-type: none"> <li>■ RMC 12.2Kbps Link</li> </ul>	<ul style="list-style-type: none"> <li>■ RMC 12.2Kbps Link</li> </ul>
WCDMA Band II	<ul style="list-style-type: none"> <li>■ RMC 12.2Kbps Link</li> </ul>	<ul style="list-style-type: none"> <li>■ RMC 12.2Kbps Link</li> </ul>
WCDMA Band IV	<ul style="list-style-type: none"> <li>■ RMC 12.2Kbps Link</li> </ul>	<ul style="list-style-type: none"> <li>■ RMC 12.2Kbps Link</li> </ul>

## 2.2 Connection Diagram of Test System

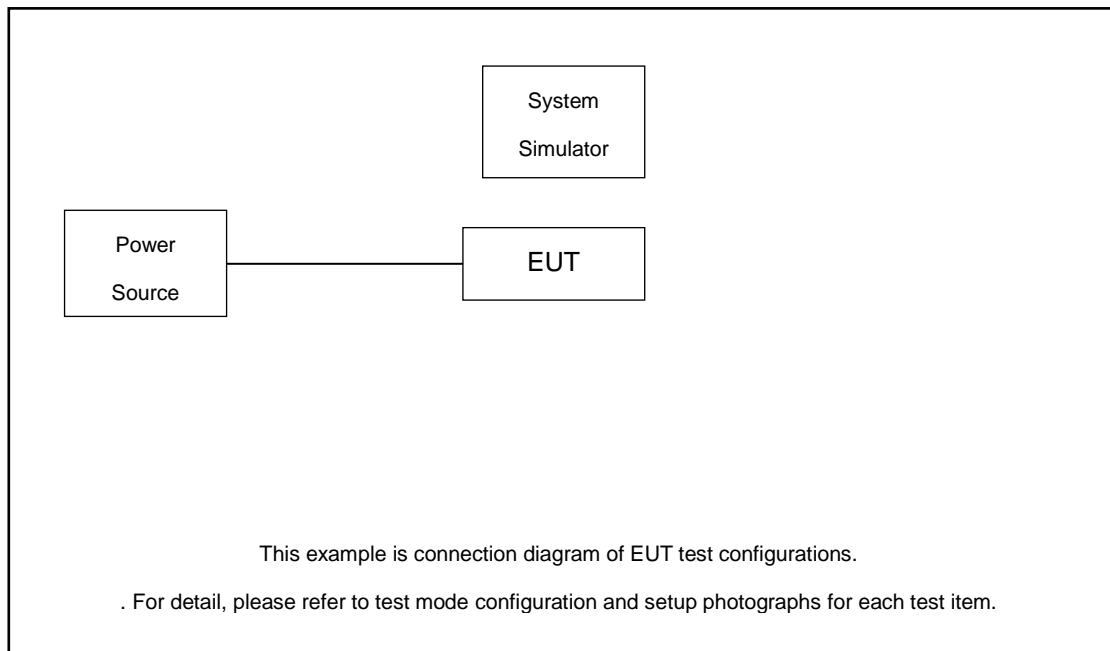

The EUT has been configuration operated in a manner tended to maximize its emission characteristics in a typical application.

## 2.3 Support Unit used in test configuration

Item	Equipment	Trade Name	Model No.	FCC ID	Data Cable	Power Cord
1.	System Simulator	R&S	CMU 200	N/A	N/A	Unshielded, 1.8 m
2.	System Simulator	Agilent	E5515C	N/A	N/A	Unshielded, 1.8 m



## 2.4 Measurement Results Explanation Example

**For all conducted test items:**

The offset level is set in the spectrum analyzer to compensate the RF cable loss and attenuator factor between RF conducted output port and spectrum analyzer. With the offset compensation, the spectrum analyzer reading level will be exactly the RF output level.

The spectrum analyzer offset is derived from RF cable loss and attenuator factor.

$$\text{Offset} = \text{RF cable loss} + \text{attenuator factor}.$$

The following shows an offset computation example with RF cable loss 4.8 dB and a 10dB attenuator.

Example :

$$\begin{aligned} \text{Offset(dB)} &= \text{RF cable loss(dB)} + \text{attenuator factor(dB)}. \\ &= 4.8 + 10 = 14.8 \text{ (dB)} \end{aligned}$$

## 2.5 Frequency List of Low/Middle/High Channels

Frequency List				
Band	Channel/Frequency(MHz)	Lowest	Middle	Highest
GSM850	Channel	128	189	251
	Frequency	824.2	836.4	848.8
WCDMA Band V	Channel	4132	4182	4233
	Frequency	826.4	836.4	846.6
GSM1900	Channel	512	661	810
	Frequency	1850.2	1880.0	1909.8
WCDMA Band II	Channel	9262	9400	9538
	Frequency	1852.4	1880.0	1907.6
WCDMA Band IV	Channel	1312	1413	1513
	Frequency	1712.4	1732.6	1752.6

### 3 Conducted Test Result

#### 3.1 Measuring Instruments

See list of measuring instruments of this test report.

#### 3.2 Test Setup

##### 3.2.1 Conducted Output Power

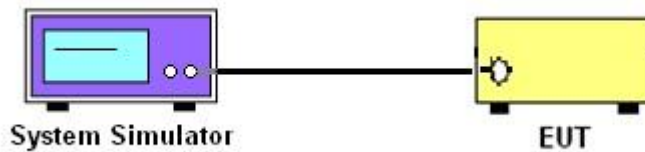

##### 3.2.2 Peak-to-Average Ratio, Occupied Bandwidth, Conducted Band-Edge and Conducted Spurious Emission

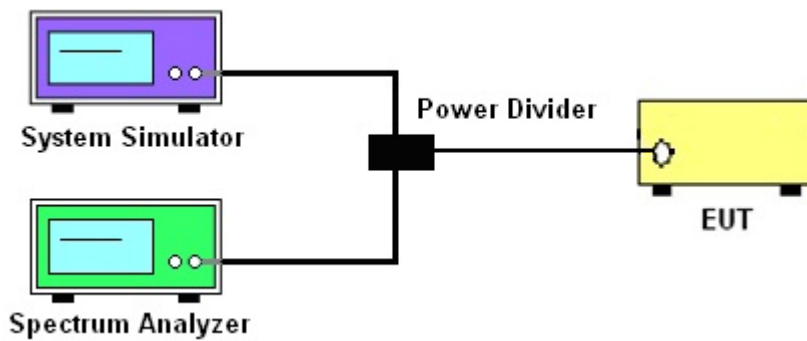

##### 3.2.3 Frequency Stability

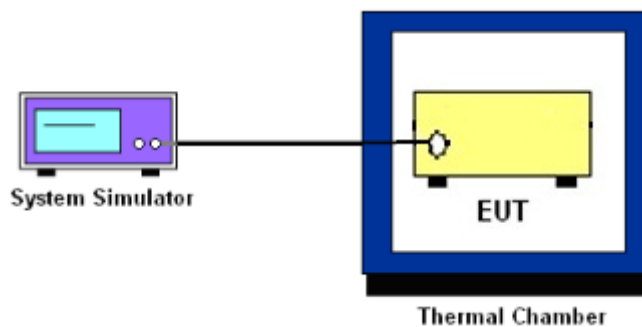

### 3.3 Test Result of Conducted Test

Please refer to Appendix A.



### 3.4 Conducted Output Power and ERP/EIRP

#### 3.4.1 Description of the Conducted Output Power and ERP/EIRP

A system simulator was used to establish communication with the EUT. Its parameters were set to enforce EUT transmitting at the maximum power. The measured power in the radio frequency on the transmitter output terminals shall be reported.

The ERP of mobile transmitters must not exceed 7 Watts for GSM850 and WCDMA Band V.

The EIRP of mobile transmitters must not exceed 2 Watts for GSM1900 and WCDMA Band II.

The EIRP of mobile transmitters must not exceed 1 Watts for WCDMA Band IV.

According to KDB 412172 D01 Power Approach,

$EIRP = P_T + G_T - L_C$ ,  $ERP = EIRP - 2.15$ , where

$P_T$  = transmitter output power in dBm

$G_T$  = gain of the transmitting antenna in dBi

$L_C$  = signal attenuation in the connecting cable between the transmitter and antenna in dB

#### 3.4.2 Test Procedures

1. The testing follows ANSI C63.26 Section 5.2
2. The transmitter output port was connected to the system simulator.
3. Set EUT at maximum power through the system simulator.
4. Select lowest, middle, and highest channels for each band and different modulation.
5. Measure and record the power level from the system simulator.



## **3.5 Peak-to-Average Ratio**

### **3.5.1 Description of the PAR Measurement**

The peak-to-average ratio (PAR) of the transmission may not exceed 13 dB.

### **3.5.2 Test Procedures**

1. The testing follows ANSI C63.26 Section 5.2.3.4 (CCDF).
2. The EUT was connected to spectrum and system simulator via a power divider.
3. Set the CCDF (Complementary Cumulative Distribution Function) option in spectrum analyzer.
4. The highest RF powers were measured and recorded the maximum PAPR level associated with a probability of 0.1 %.
5. Record the deviation as Peak to Average Ratio.



### 3.6 99% Occupied Bandwidth and 26dB Bandwidth Measurement

#### 3.6.1 Description of 99% Occupied Bandwidth and 26dB Bandwidth Measurement

The occupied bandwidth is the width of a frequency band such that, below the lower and above the upper frequency limits, the mean powers emitted are each equal to a specified percentage 0.5% of the total mean transmitted power.

The 26 dB emission bandwidth is defined as the frequency range between two points, one above and one below the carrier frequency, at which the spectral density of the emission is attenuated 26 dB below the maximum in-band spectral density of the modulated signal. Spectral density (power per unit bandwidth) is to be measured with a detector of resolution bandwidth equal to approximately 1.0% of the emission bandwidth.

#### 3.6.2 Test Procedures

1. The testing follows ANSI C63.26 Section 5.4
2. The EUT was connected to spectrum analyzer and system simulator via a power divider.
3. The spectrum analyzer center frequency is set to the nominal EUT channel center frequency. The span range for the spectrum analyzer shall be between two and five times the anticipated OBW.
4. The nominal resolution bandwidth (RBW) shall be in the range of 1 to 5 % of the anticipated OBW, and the VBW shall be at least 3 times the RBW.
5. Set the detection mode to peak, and the trace mode to max hold.
6. Determine the reference value: Set the EUT to transmit a modulated signal. Allow the trace to stabilize. Set the spectrum analyzer marker to the highest level of the displayed trace. (this is the reference value)
7. Determine the “-26 dB down amplitude” as equal to (Reference Value – X).
8. Place two markers, one at the lowest and the other at the highest frequency of the envelope of the spectral display such that each marker is at or slightly below the “-X dB down amplitude” determined in step 6. If a marker is below this “-X dB down amplitude” value it shall be placed as close as possible to this value. The OBW is the positive frequency difference between the two markers.
9. Use the 99 % power bandwidth function of the spectrum analyzer and report the measured bandwidth.



## **3.7 Conducted Band Edge**

### **3.7.1 Description of Conducted Band Edge Measurement**

The power of any emission outside of the authorized operating frequency ranges must be lower than the transmitter power (P) by a factor of at least  $43 + 10 \log (P)$  dB.

### **3.7.2 Test Procedures**

1. The testing follows ANSI C63.26 section 5.7
2. The EUT was connected to the spectrum analyzer and system simulator via a power divider.
3. The RF output of EUT was connected to the spectrum analyzer by an RF cable and attenuator. The path loss was compensated to the results for each measurement.
4. The band edges of low and high channels for the highest RF powers were measured.
5. The RF fundamental frequency should be excluded against the limit line in the operating frequency band.
6. The limit line is derived from  $43 + 10\log(P)$  dB below the transmitter power P(Watts)



## 3.8 Conducted Spurious Emission

### 3.8.1 Description of Conducted Spurious Emission Measurement

The power of any emission outside of the authorized operating frequency ranges must be lower than the transmitter power (P) by a factor of at least  $43 + 10 \log (P)$  dB.

It is measured by means of a calibrated spectrum analyzer and scanned from 30 MHz up to a frequency including its 10<sup>th</sup> harmonic.

### 3.8.2 Test Procedures

1. The testing follows ANSI C63.26 section 5.7
2. The EUT was connected to the spectrum analyzer and system simulator via a power divider.
3. The RF output of EUT was connected to the spectrum analyzer by an RF cable and attenuator. The path loss was compensated to the results for each measurement.
4. The middle channel for the highest RF power within the transmitting frequency was measured.
5. The conducted spurious emission for the whole frequency range was taken.
6. The RF fundamental frequency should be excluded against the limit line in the operating frequency band.
7. The limit line is derived from  $43 + 10\log(P)$  dB below the transmitter power P(Watts)



## 3.9 Frequency Stability

### 3.9.1 Description of Frequency Stability Measurement

The frequency stability shall be measured by variation of ambient temperature and variation of primary supply voltage to ensure that the fundamental emission stays within the authorized frequency block. The frequency stability of the transmitter shall be maintained within  $\pm 0.00025\%$  ( $\pm 2.5\text{ppm}$ ) of the center frequency.

### 3.9.2 Test Procedures for Temperature Variation

1. The testing follows ANSI C63.26 section 5.6.4
2. The EUT was set up in the thermal chamber and connected with the system simulator.
3. With power OFF, the temperature was decreased to  $-30^{\circ}\text{C}$  and the EUT was stabilized before testing. Power was applied and the maximum change in frequency was recorded within one minute.
4. With power OFF, the temperature was raised in  $10^{\circ}\text{C}$  step up to  $50^{\circ}\text{C}$ . The EUT was stabilized at each step for at least half an hour. Power was applied and the maximum frequency change was recorded within one minute.

### 3.9.3 Test Procedures for Voltage Variation

1. The testing follows ANSI C63.26 section 5.6.5
2. The EUT was placed in a temperature chamber at  $20\pm 5^{\circ}\text{C}$  and connected with the system simulator.
3. The power supply voltage to the EUT was varied from 85% to 115% of the nominal value for other than hand carried battery equipment.
4. For hand carried, battery powered equipment, reduce the primary ac or dc supply voltage to the battery operating end point, which shall be specified by the manufacturer.
5. The variation in frequency was measured for the worst case.

## 4 Radiated Test Items

### 4.1 Measuring Instruments

See list of measuring instruments of this test report.

### 4.2 Test Setup

#### 4.2.1 For radiated test below 30MHz

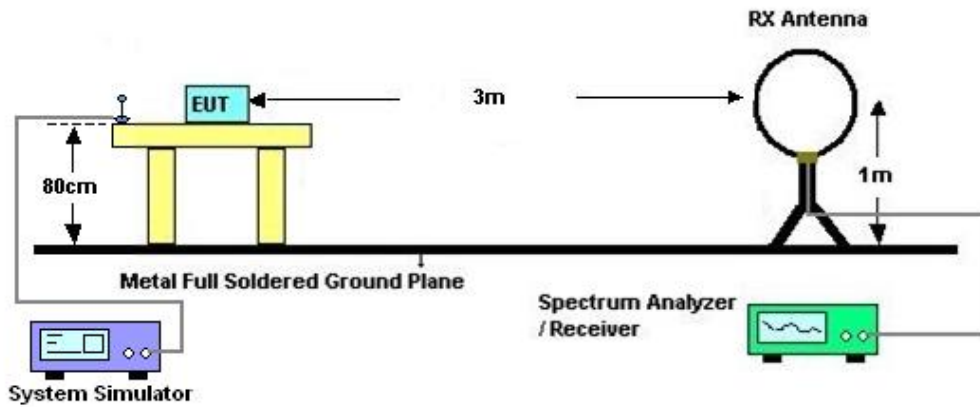

#### 4.2.2 For radiated test from 30MHz to 1GHz

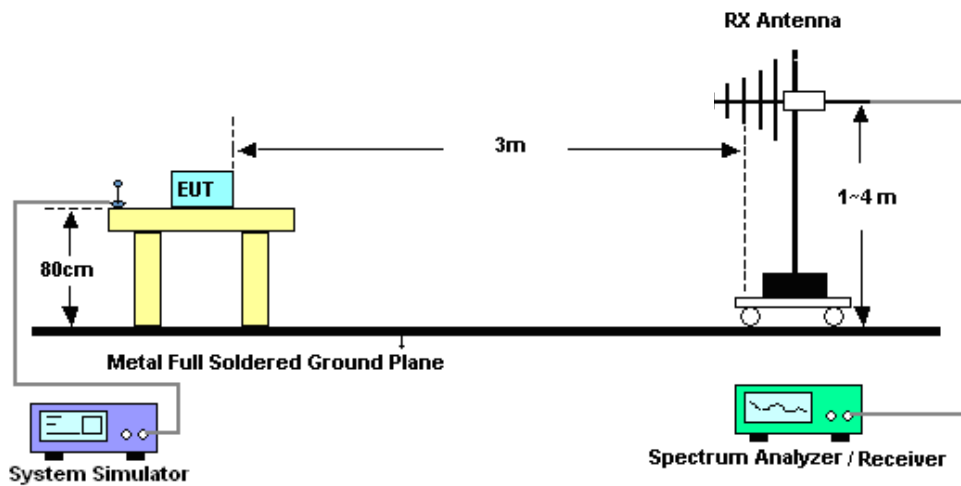

### 4.2.3 For radiated test above 1GHz

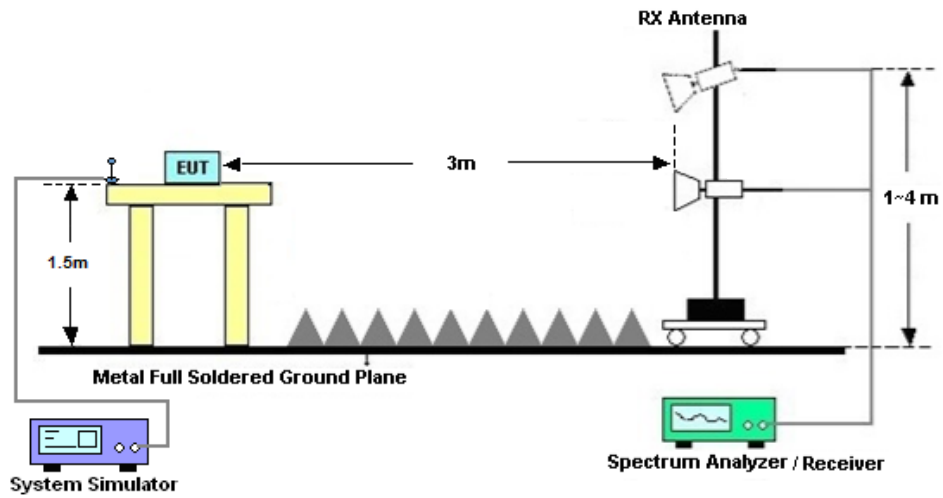

## 4.3 Test Result of Radiated Test

The low frequency, which started from 9 kHz to 30MHz, was pre-scanned and the result which was 20dB lower than the limit line was not reported.

Please refer to Appendix B.



## 4.4 Field Strength of Spurious Radiation Measurement

### 4.4.1 Description of Field Strength of Spurious Radiated Measurement

The power of any emission outside of the authorized operating frequency ranges must be attenuated below the transmitter power (P) by a factor of at least  $43 + 10 \log (P)$  dB. The spectrum is scanned from 30 MHz up to a frequency including its 10th harmonic.

### 4.4.2 Test Procedures

1. The testing follows ANSI C63.26 Section 5.5
2. The EUT was placed on a rotatable wooden table 0.8 meters for frequency below 1GHz and 1.5 meter for frequency above 1GHz above the ground.
3. The EUT was set 3 meters from the receiving antenna, which was mounted on the antenna tower.
4. The table was rotated 360 degrees to determine the position of the highest spurious emission.
5. The height of the receiving antenna is varied between one meter and four meters to search for the maximum spurious emission for both horizontal and vertical polarizations.
6. Make the measurement with the spectrum analyzer's RBW = 1MHz, VBW = 3MHz, taking record of maximum spurious emission.
7. A horn antenna was substituted in place of the EUT and was driven by a signal generator.
8. Tune the output power of signal generator to the same emission level with EUT maximum spurious emission.
9. Taking the record of output power at antenna port.
10. Repeat step 7 to step 8 for another polarization.
11.  $EIRP \text{ (dBm)} = S.G. \text{ Power} - Tx \text{ Cable Loss} + Tx \text{ Antenna Gain}$
12.  $ERP \text{ (dBm)} = EIRP - 2.15$
13. The RF fundamental frequency should be excluded against the limit line in the operating frequency band.
14. The limit line is derived from  $43 + 10\log(P)$  dB below the transmitter power P(Watts)



## 5 List of Measuring Equipment

Instrument	Manufacturer	Model No.	Serial No.	Characteristics	Calibration Date	Test Date	Due Date	Remark
Spectrum Analyzer	R&S	FSV40	101040	10Hz~40GHz	Oct. 10, 2024	Apr. 03, 2025	Oct. 09, 2025	Conducted (TH01-KS)
Power divider	STI	STI08-0055	-	0.5~40GHz	NCR	Apr. 03, 2025	NCR	Conducted (TH01-KS)
Temperature & humidity	Hongzhan	LP-150U	H2014011440	-40~+150°C 20%~95%RH	Jul. 04, 2024	Apr. 03, 2025	Jul. 03, 2025	Conducted (TH01-KS)
EXA Spectrum Analyzer	KEYSIGHT	N9010A	MY55150213	10Hz~44GHz	Jul. 03, 2024	Mar. 29, 2025	Jul. 02, 2025	Radiation (03CH02-SZ)
Loop Antenna	R&S	HFH2-Z2E	101141	9kHz~30MHz	Dec. 28, 2024	Mar. 29, 2025	Dec. 27, 2025	Radiation (03CH02-SZ)
Bilog Antenna	TeseQ	CBL6112D	35407	30MHz-2GHz	Oct. 24, 2023	Mar. 29, 2025	Oct. 23, 2025	Radiation (03CH02-SZ)
Double Ridge Horn Antenna	ETS-Lindgren	3117	00119436	1GHz~18GHz	Jul. 04, 2024	Mar. 29, 2025	Jul. 04, 2025	Radiation (03CH02-SZ)
HF Amplifier	MITEQ	TTA1840-35-HG	1871923	18GHz~40GHz	Jul. 03, 2024	Mar. 29, 2025	Jul. 03, 2025	Radiation (03CH02-SZ)
SHF-EHF Horn	com-power	AH-840	101071	18Ghz-40GHz	Apr. 09, 2024	Mar. 29, 2025	Apr. 08, 2025	Radiation (03CH02-SZ)
LF Amplifier	Burgeon	BPA-530	102211	0.01~3000Mhz	Oct. 18, 2024	Mar. 29, 2025	Oct. 17, 2025	Radiation (03CH02-SZ)
HF Amplifier	KEYSIGHT	83017A	MY53270105	0.5GHz~26.5Ghz	Oct. 14, 2024	Mar. 29, 2025	Oct. 13, 2025	Radiation (03CH02-SZ)
AC Power Source	Chroma	61601	616010003043	N/A	Oct. 18, 2024	Mar. 29, 2025	Oct. 17, 2025	Radiation (03CH02-SZ)
Turn Table	Chaintek	T-200	N/A	0~360 degree	NCR	Mar. 29, 2025	NCR	Radiation (03CH02-SZ)
Antenna Mast	Chaintek	MBS-400	N/A	1 m~4 m	NCR	Mar. 29, 2025	NCR	Radiation (03CH02-SZ)

NCR: No Calibration Required



## 6 Measurement Uncertainty

The measurement uncertainties shown below were calculated in accordance with the requirements of ANSI 63.26-2015. All the measurement uncertainty value were shown with a coverage K=2 to indicate 95% level of confidence. The measurement data show herein meets or exceeds the CISPR measurement uncertainty values specified in CISPR 16-4-2 and can be compared directly to specified limit to determine compliance.

### Uncertainty of Conducted Measurement

Conducted Spurious Emission & Bandedge	±2.22 dB
Occupied Channel Bandwidth	±0.1%
Conducted Power	±0.50 dB
Peak to Average Ratio	±0.90 dB
Frequency Stability	±0.04 ppm

### Uncertainty of Radiated Emission Measurement (30 MHz ~ 1000 MHz)

Measuring Uncertainty for a Level of Confidence of 95% (U = 2Uc(y))	2.47 dB
---	---------

### Uncertainty of Radiated Emission Measurement (1 GHz ~ 18 GHz)

Measuring Uncertainty for a Level of Confidence of 95% (U = 2Uc(y))	3.31 dB
---	---------

### Uncertainty of Radiated Emission Measurement (18 GHz ~ 40 GHz)

Measuring Uncertainty for a Level of Confidence of 95% (U = 2Uc(y))	3.72 dB
---	---------

----- THE END -----



### Appendix A. Test Results of Conducted Test

Test Engineer :	Smile Wang	Temperature :	22~23°C
		Relative Humidity :	40~42%

### Conducted Output Power(Average power) and ERP/EIRP

#### GSM 850\_ANT0:

GSM850 TX Channel	Burst Average Power (dBm)			ERP(W)		
	128	189	251	L	M	H
Frequency (MHz)	824.2	836.4	848.8			
GSM 1 Tx slot	31.75	31.76	31.61	0.2630	0.2636	0.2547
GPRS 1 Tx slot	31.74	31.63	31.60	0.2624	0.2559	0.2541
GPRS 2 Tx slots	30.23	30.08	30.05	0.1854	0.1791	0.1778
GPRS 3 Tx slots	28.77	28.61	28.62	0.1324	0.1276	0.1279
GPRS 4 Tx slots	27.25	27.16	27.15	0.0933	0.0914	0.0912
EDGE 1 Tx slot	26.18	26.20	26.16	0.0729	0.0733	0.0726
EDGE 2 Tx slots	24.41	24.65	24.63	0.0485	0.0513	0.0511
EDGE 3 Tx slots	22.61	22.78	22.73	0.0321	0.0333	0.0330
EDGE 4 Tx slots	20.98	21.02	21.03	0.0220	0.0222	0.0223

#### GSM1900\_ANT1:

GSM1900 TX Channel	Burst Average Power (dBm)			EIRP(W)		
	512	661	810	L	M	H
Frequency (MHz)	1850.2	1880	1909.8			
GSM 1 Tx slot	28.42	28.52	28.43	0.3404	0.3483	0.3412
GPRS 1 Tx slot	28.39	28.49	28.36	0.3381	0.3459	0.3357
GPRS 2 Tx slots	26.86	26.92	26.84	0.2377	0.2410	0.2366
GPRS 3 Tx slots	25.39	25.39	25.36	0.1694	0.1694	0.1683
GPRS 4 Tx slots	23.89	23.90	23.83	0.1199	0.1202	0.1183
EDGE 1 Tx slot	23.15	23.23	22.99	0.1012	0.1030	0.0975
EDGE 2 Tx slots	21.43	21.48	21.24	0.0681	0.0689	0.0652
EDGE 3 Tx slots	19.61	19.70	19.36	0.0448	0.0457	0.0423
EDGE 4 Tx slots	17.69	17.93	17.65	0.0288	0.0304	0.0285



**WCDMA Band V\_ANT0:**

Band		WCDMA V			ERP(W)		
TX Channel		4132	4182	4233			
Rx Channel		4357	4407	4458			
Frequency (MHz)		826.4	836.4	846.6	L	M	H
3GPP Rel 99	AMR 12.2Kbps	22.29	22.46	22.46	0.0298	0.0310	0.0310
3GPP Rel 99	RMC 12.2Kbps	22.53	22.58	22.49	0.0315	0.0318	0.0312
3GPP Rel 6	HSDPA Subtest-1	21.44	21.64	21.68	0.0245	0.0256	0.0259
3GPP Rel 6	HSDPA Subtest-2	21.56	21.67	21.63	0.0252	0.0258	0.0256
3GPP Rel 6	HSDPA Subtest-3	21.04	21.09	21.07	0.0223	0.0226	0.0225
3GPP Rel 6	HSDPA Subtest-4	21.05	21.04	21.13	0.0224	0.0223	0.0228
3GPP Rel 8	DC-HSDPA Subtest-1	21.40	21.49	21.64	0.0243	0.0248	0.0256
3GPP Rel 8	DC-HSDPA Subtest-2	21.46	21.52	21.55	0.0246	0.0249	0.0251
3GPP Rel 8	DC-HSDPA Subtest-3	20.88	21.15	20.98	0.0215	0.0229	0.0220
3GPP Rel 8	DC-HSDPA Subtest-4	21.08	21.10	21.02	0.0225	0.0226	0.0222
3GPP Rel 6	HSUPA Subtest-1	21.47	21.52	21.54	0.0247	0.0249	0.0251
3GPP Rel 6	HSUPA Subtest-2	19.63	19.49	19.62	0.0161	0.0156	0.0161
3GPP Rel 6	HSUPA Subtest-3	20.58	20.53	20.58	0.0201	0.0199	0.0201
3GPP Rel 6	HSUPA Subtest-4	19.50	19.73	19.59	0.0157	0.0165	0.0160
3GPP Rel 6	HSUPA Subtest-5	21.50	21.60	21.57	0.0248	0.0254	0.0252
3GPP Rel 7	HSPA+ (16QAM) Subtest-1	18.95	19.00	19.06	0.0138	0.0140	0.0142

**WCDMA Band II\_ANT1:**

Band		WCDMA II			EIRP(W)		
TX Channel		9262	9400	9538			
Rx Channel		9662	9800	9938			
Frequency (MHz)		1852.4	1880	1907.6	L	M	H
3GPP Rel 99	AMR 12.2Kbps	22.47	22.65	22.51	0.0865	0.0902	0.0873
3GPP Rel 99	RMC 12.2Kbps	22.64	22.70	22.68	0.0899	0.0912	0.0908
3GPP Rel 6	HSDPA Subtest-1	21.61	21.72	21.73	0.0710	0.0728	0.0729
3GPP Rel 6	HSDPA Subtest-2	21.65	21.77	21.69	0.0716	0.0736	0.0723
3GPP Rel 6	HSDPA Subtest-3	21.17	21.19	21.24	0.0641	0.0644	0.0652
3GPP Rel 6	HSDPA Subtest-4	21.21	21.23	21.18	0.0647	0.0650	0.0643
3GPP Rel 8	DC-HSDPA Subtest-1	21.59	21.67	21.76	0.0706	0.0719	0.0735
3GPP Rel 8	DC-HSDPA Subtest-2	21.60	21.66	21.63	0.0708	0.0718	0.0713
3GPP Rel 8	DC-HSDPA Subtest-3	21.07	21.22	21.17	0.0627	0.0649	0.0641
3GPP Rel 8	DC-HSDPA Subtest-4	21.22	21.20	21.16	0.0649	0.0646	0.0640
3GPP Rel 6	HSUPA Subtest-1	21.64	21.68	21.69	0.0714	0.0721	0.0723
3GPP Rel 6	HSUPA Subtest-2	19.69	19.67	19.69	0.0456	0.0454	0.0456
3GPP Rel 6	HSUPA Subtest-3	20.67	20.70	20.64	0.0571	0.0575	0.0568
3GPP Rel 6	HSUPA Subtest-4	19.61	19.78	19.68	0.0448	0.0466	0.0455
3GPP Rel 6	HSUPA Subtest-5	21.64	21.73	21.63	0.0714	0.0729	0.0713
3GPP Rel 7	HSPA+ (16QAM) Subtest-1	19.06	19.15	19.14	0.0394	0.0403	0.0402



WCDMA Band IV\_ANT1:

Band		WCDMA IV			EIRP(W)		
TX Channel		1312	1413	1513			
Rx Channel		1537	1638	1738			
Frequency (MHz)		1712.4	1732.6	1752.6	L	M	H
3GPP Rel 99	AMR 12.2Kbps	22.55	22.64	22.55	0.0785	0.0802	0.0785
3GPP Rel 99	RMC 12.2Kbps	22.66	22.72	22.65	0.0805	0.0817	0.0804
3GPP Rel 6	HSDPA Subtest-1	21.58	21.74	21.66	0.0628	0.0652	0.0640
3GPP Rel 6	HSDPA Subtest-2	21.58	21.68	21.72	0.0628	0.0643	0.0649
3GPP Rel 6	HSDPA Subtest-3	21.12	21.24	21.21	0.0565	0.0581	0.0577
3GPP Rel 6	HSDPA Subtest-4	21.21	21.22	21.23	0.0577	0.0578	0.0579
3GPP Rel 8	DC-HSDPA Subtest-1	21.68	21.66	21.67	0.0643	0.0640	0.0641
3GPP Rel 8	DC-HSDPA Subtest-2	21.62	21.80	21.61	0.0634	0.0661	0.0632
3GPP Rel 8	DC-HSDPA Subtest-3	21.19	21.21	21.15	0.0574	0.0577	0.0569
3GPP Rel 8	DC-HSDPA Subtest-4	21.20	21.20	21.10	0.0575	0.0575	0.0562
3GPP Rel 6	HSUPA Subtest-1	21.69	21.78	21.61	0.0644	0.0658	0.0632
3GPP Rel 6	HSUPA Subtest-2	19.61	19.74	19.70	0.0399	0.0411	0.0407
3GPP Rel 6	HSUPA Subtest-3	20.64	20.71	20.71	0.0506	0.0514	0.0514
3GPP Rel 6	HSUPA Subtest-4	19.66	19.65	19.65	0.0404	0.0403	0.0403
3GPP Rel 6	HSUPA Subtest-5	21.73	21.67	21.58	0.0650	0.0641	0.0628
3GPP Rel 7	HSPA+ (16QAM) Subtest-1	19.13	19.27	19.19	0.0357	0.0369	0.0362



## A1. GSM

### Peak-to-Average Ratio

Mode	GSM850		Limit: 13dB
Mod.	GSM	EDGE class 8	Result
Lowest CH	0.17	3.07	PASS
Middle CH	0.12	3.07	
Highest CH	0.20	3.04	

Mode	GSM1900		Limit: 13dB
Mod.	GSM	EDGE class 8	Result
Lowest CH	0.17	2.75	PASS
Middle CH	0.17	2.67	
Highest CH	0.17	2.72	

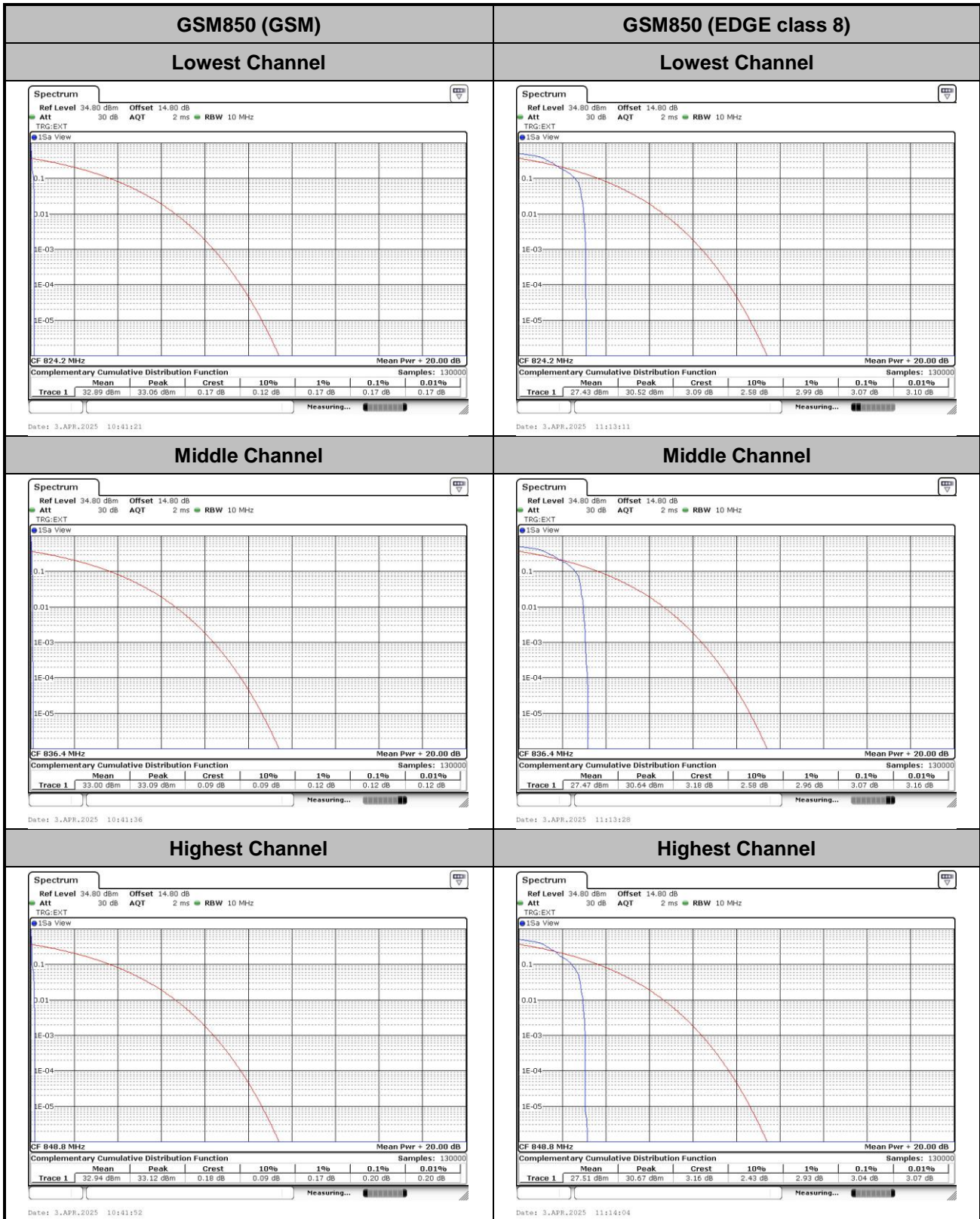



GSM1900 (GSM)

Lowest Channel

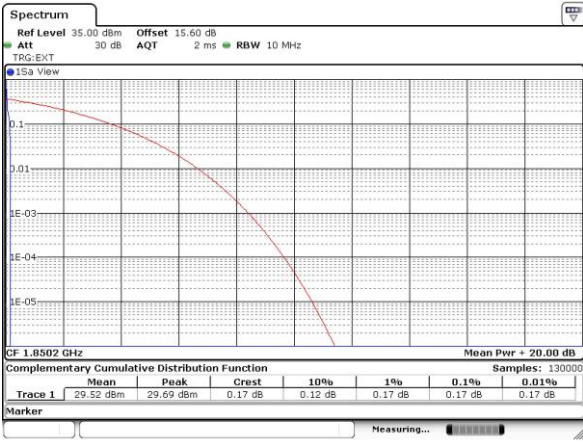

Date: 3.APR.2025 15:44:56

GSM1900 (EDGE class 8)

Lowest Channel



Date: 3.APR.2025 16:04:29

Middle Channel

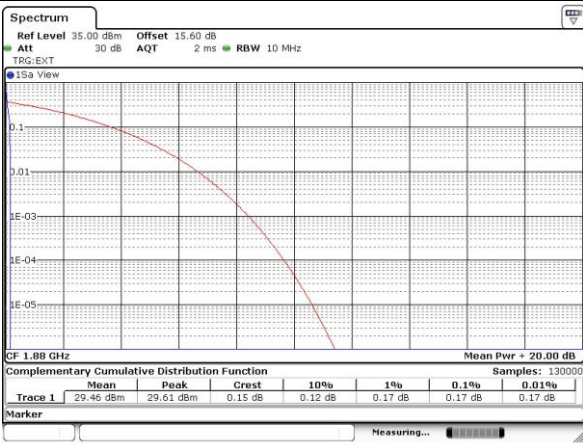

Date: 3.APR.2025 15:45:09

Middle Channel



Date: 3.APR.2025 16:04:42

Highest Channel

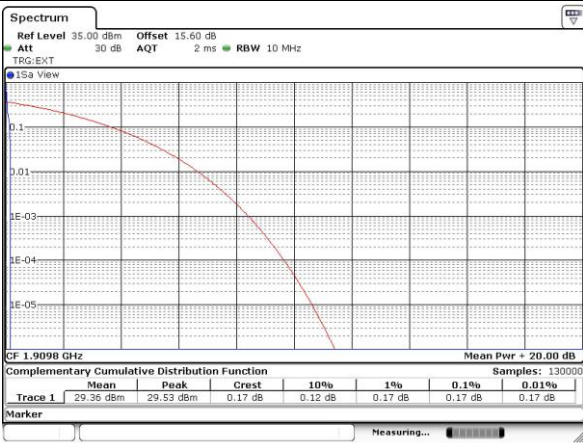

Date: 3.APR.2025 15:45:21

Highest Channel



Date: 3.APR.2025 16:04:55



**26dB Bandwidth**

Mode	GSM850	
Mod.	GSM	EDGE class 8
Lowest CH	0.317	0.313
Middle CH	0.317	0.315
Highest CH	0.314	0.318

Mode	GSM1900	
Mod.	GSM	EDGE class 8
Lowest CH	0.314	0.322
Middle CH	0.315	0.324
Highest CH	0.315	0.328



GSM850 (GSM)

Lowest Channel



Date: 3.APR.2025 10:11:33

GSM850 (EDGE class 8)

Lowest Channel



Date: 3.APR.2025 10:47:09

Middle Channel

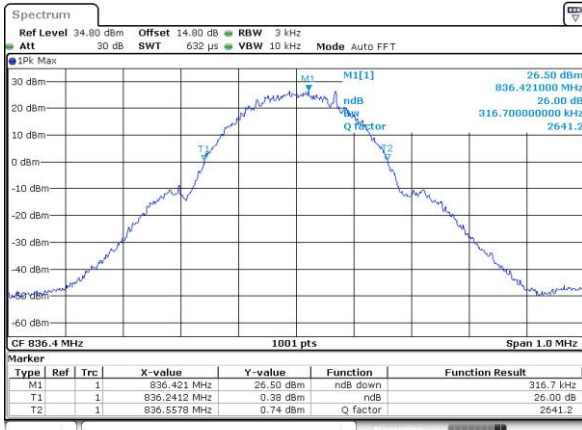

Date: 3.APR.2025 10:12:09

Middle Channel

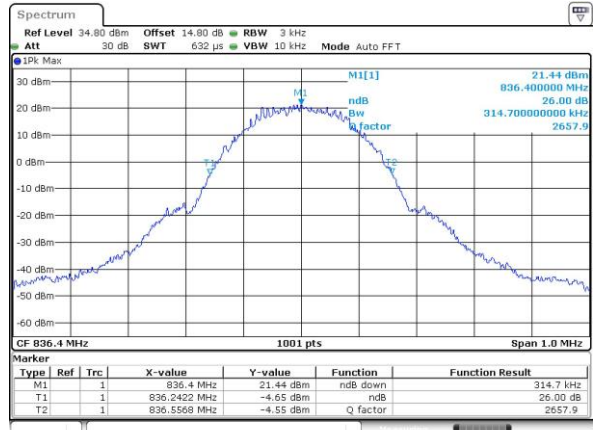

Date: 3.APR.2025 10:47:37

Highest Channel

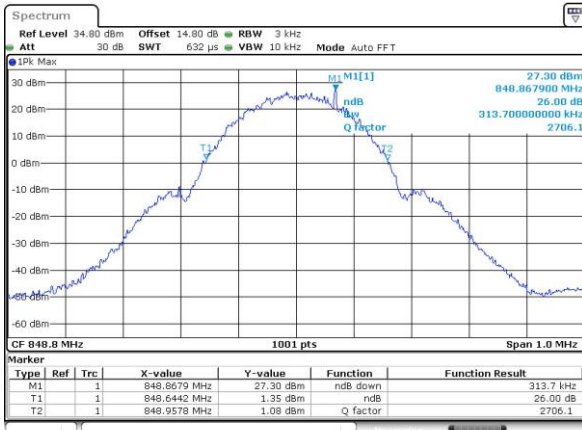

Date: 3.APR.2025 10:18:16

Highest Channel

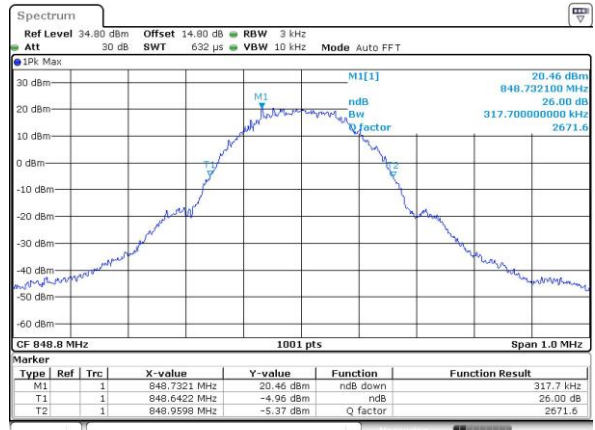

Date: 3.APR.2025 10:48:03



GSM1900 (GSM)

Lowest Channel

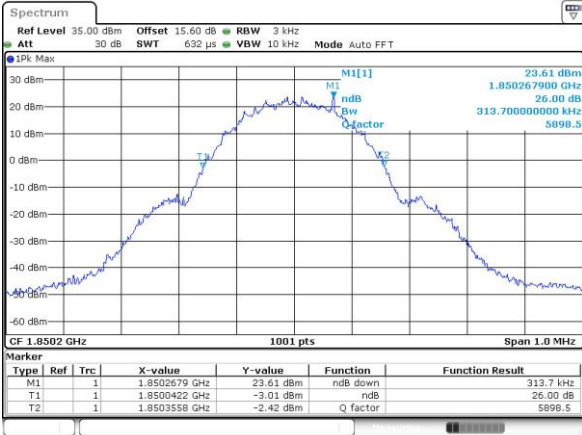

Date: 3.APR.2025 15:39:26

GSM1900 (EDGE class 8)

Lowest Channel

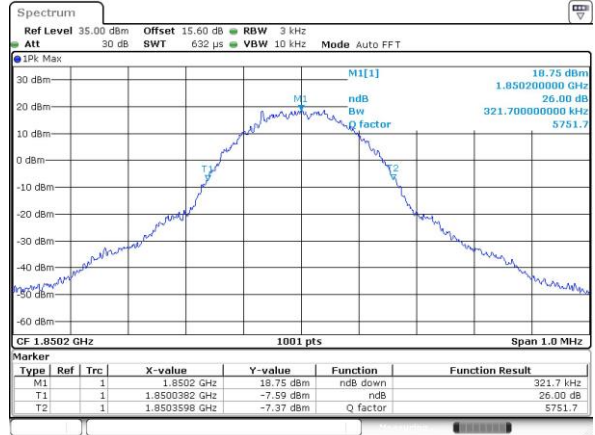

Date: 3.APR.2025 15:59:20

Middle Channel



Date: 3.APR.2025 15:39:56

Middle Channel

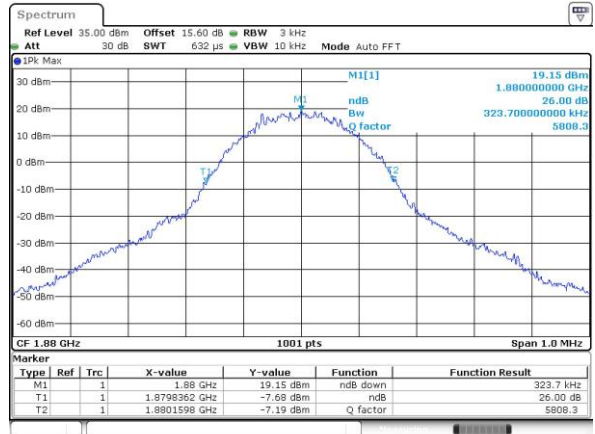

Date: 3.APR.2025 15:59:42

Highest Channel



Date: 3.APR.2025 15:40:26

Highest Channel

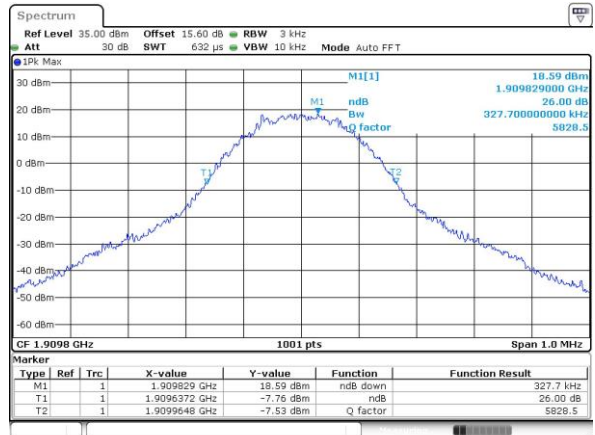

Date: 3.APR.2025 16:00:11



### Occupied Bandwidth

Mode	GSM850	
Mod.	GSM	EDGE class 8
Lowest CH	0.244	0.246
Middle CH	0.244	0.249
Highest CH	0.245	0.242

Mode	GSM1900	
Mod.	GSM	EDGE class 8
Lowest CH	0.245	0.256
Middle CH	0.242	0.254
Highest CH	0.244	0.254



GSM850 (GSM)

Lowest Channel

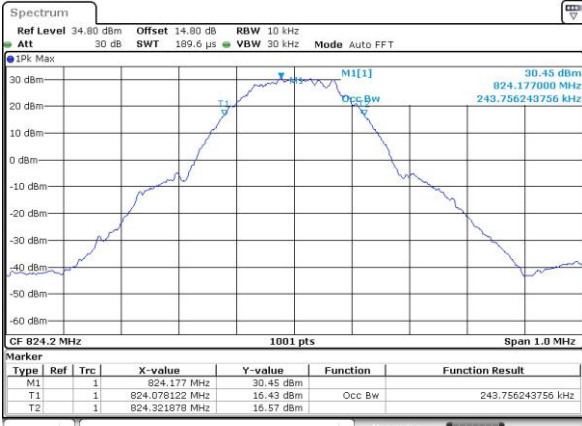

Date: 3.APR.2025 10:19:06

GSM850 (EDGE class 8)

Lowest Channel

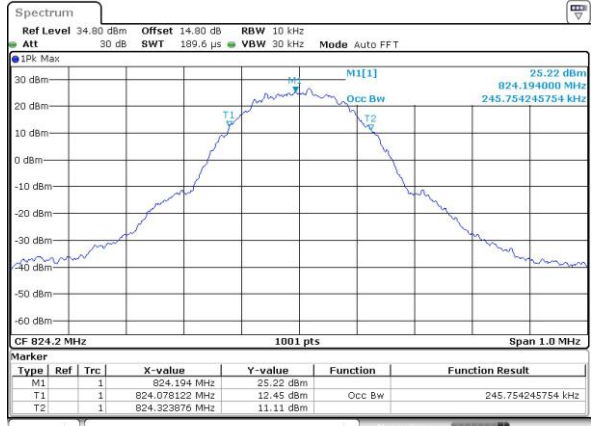

Date: 3.APR.2025 10:49:44

Middle Channel

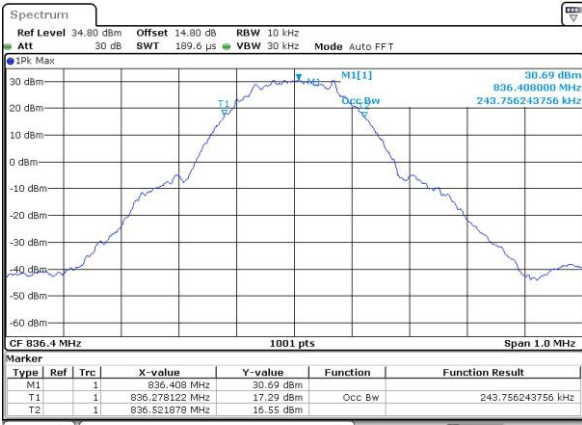

Date: 3.APR.2025 10:19:28

Middle Channel

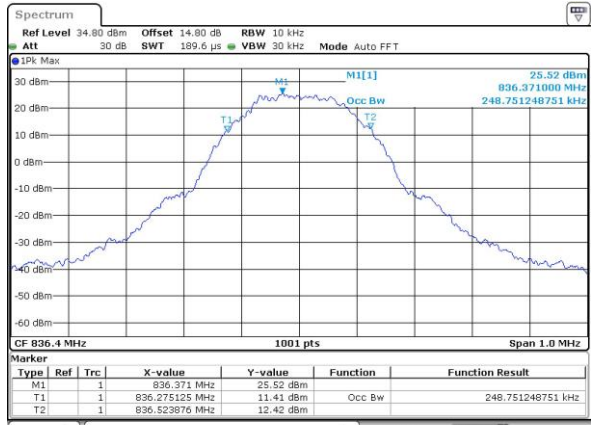

Date: 3.APR.2025 10:50:14

Highest Channel

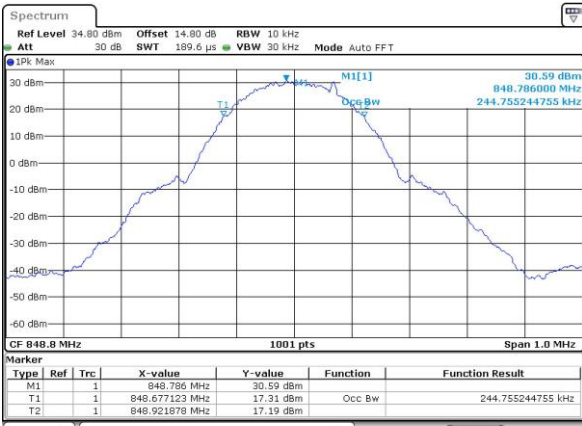

Date: 3.APR.2025 10:19:58

Highest Channel

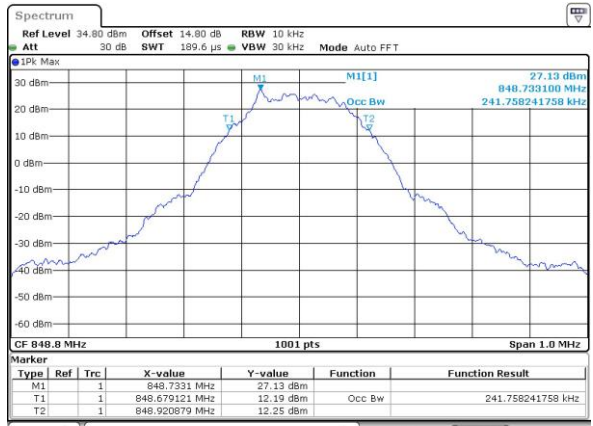

Date: 3.APR.2025 10:51:30



GSM1900 (GSM)

Lowest Channel

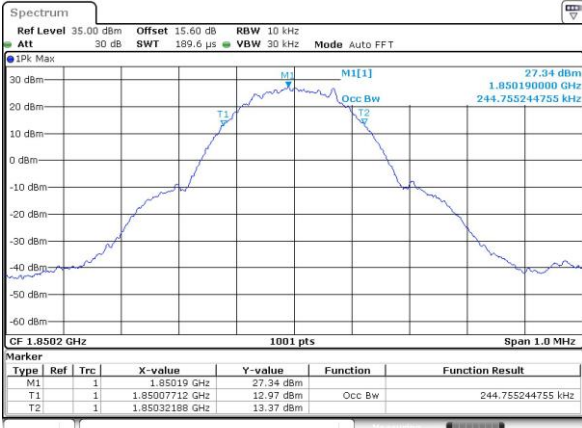

Date: 3.APR.2025 15:40:52

GSM1900 (EDGE class 8)

Lowest Channel

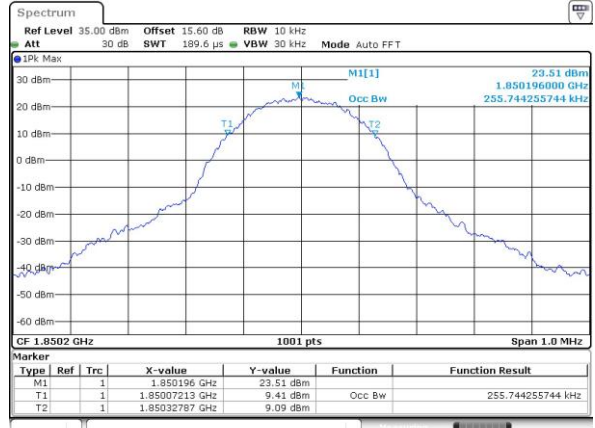

Date: 3.APR.2025 16:00:39

Middle Channel

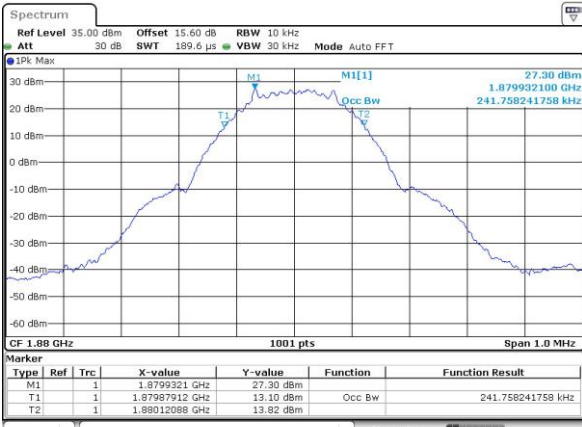

Date: 3.APR.2025 15:41:15

Middle Channel

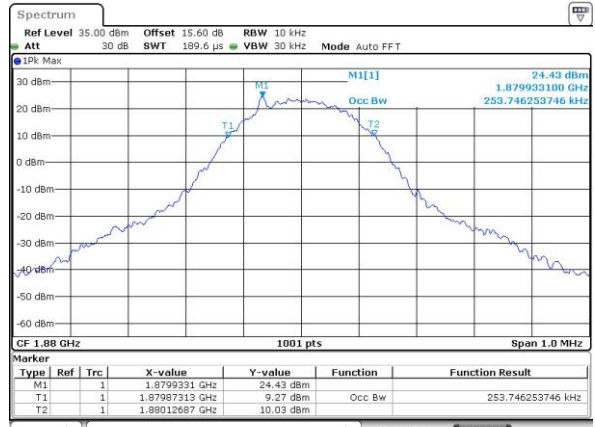

Date: 3.APR.2025 16:01:03

Highest Channel

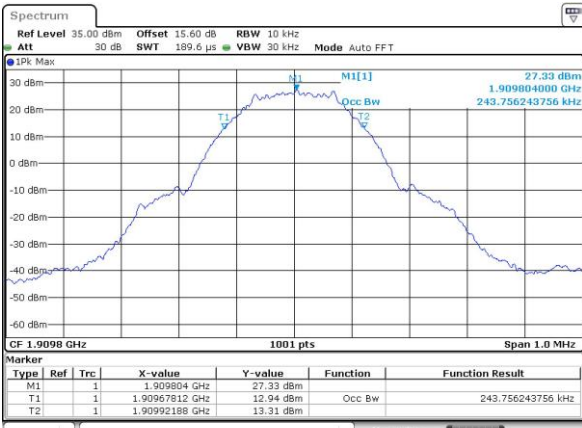

Date: 3.APR.2025 15:41:53

Highest Channel

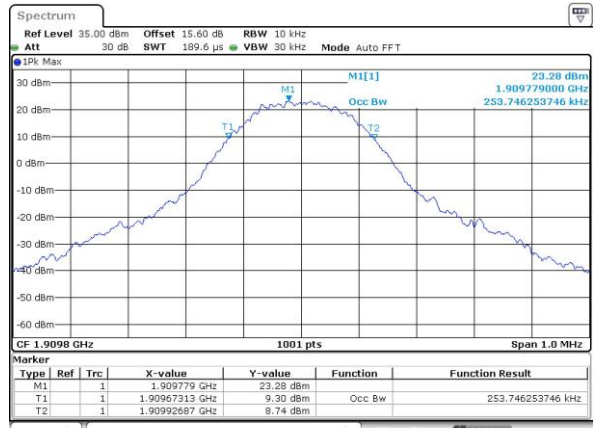

Date: 3.APR.2025 16:01:29



# Conducted Band Edge

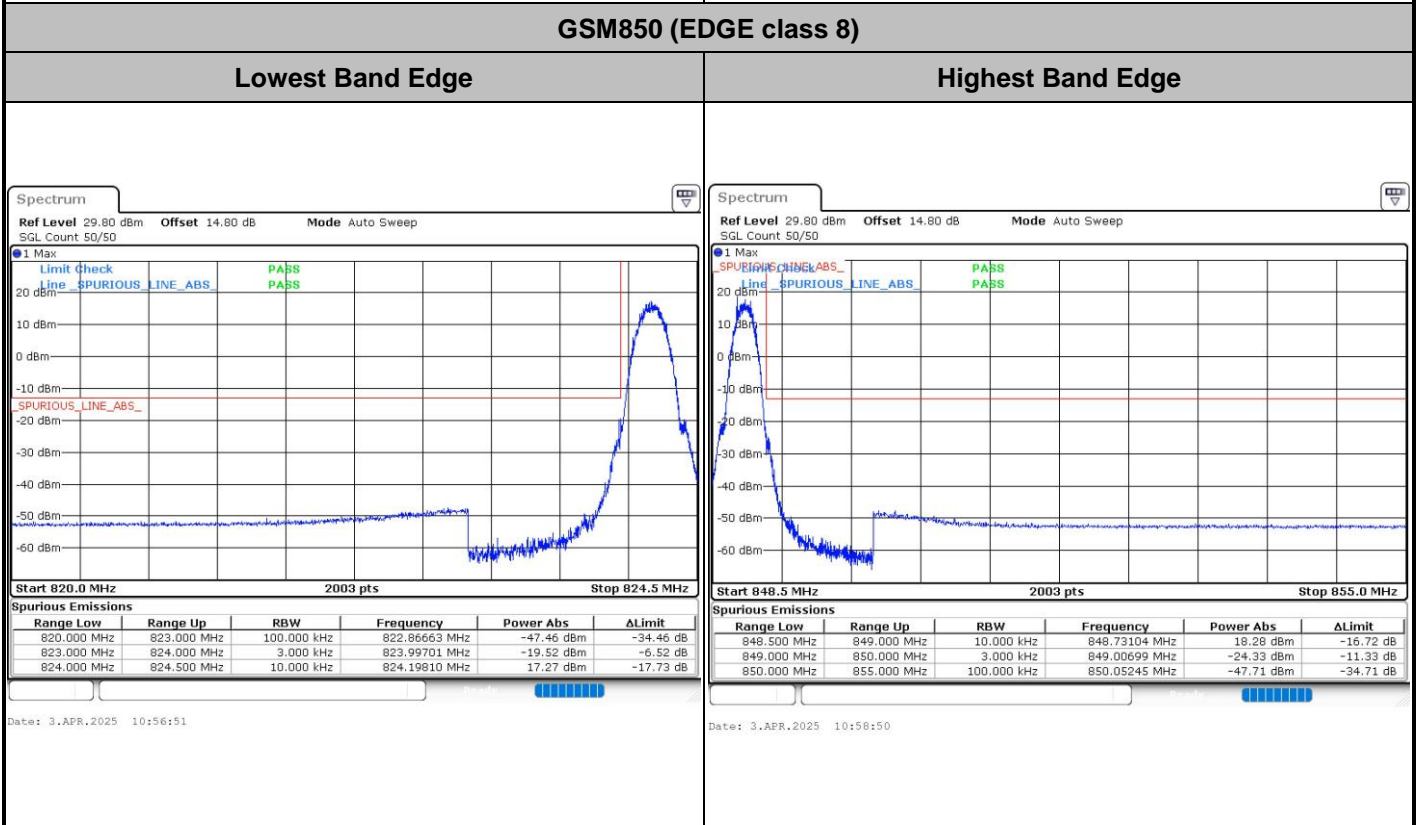
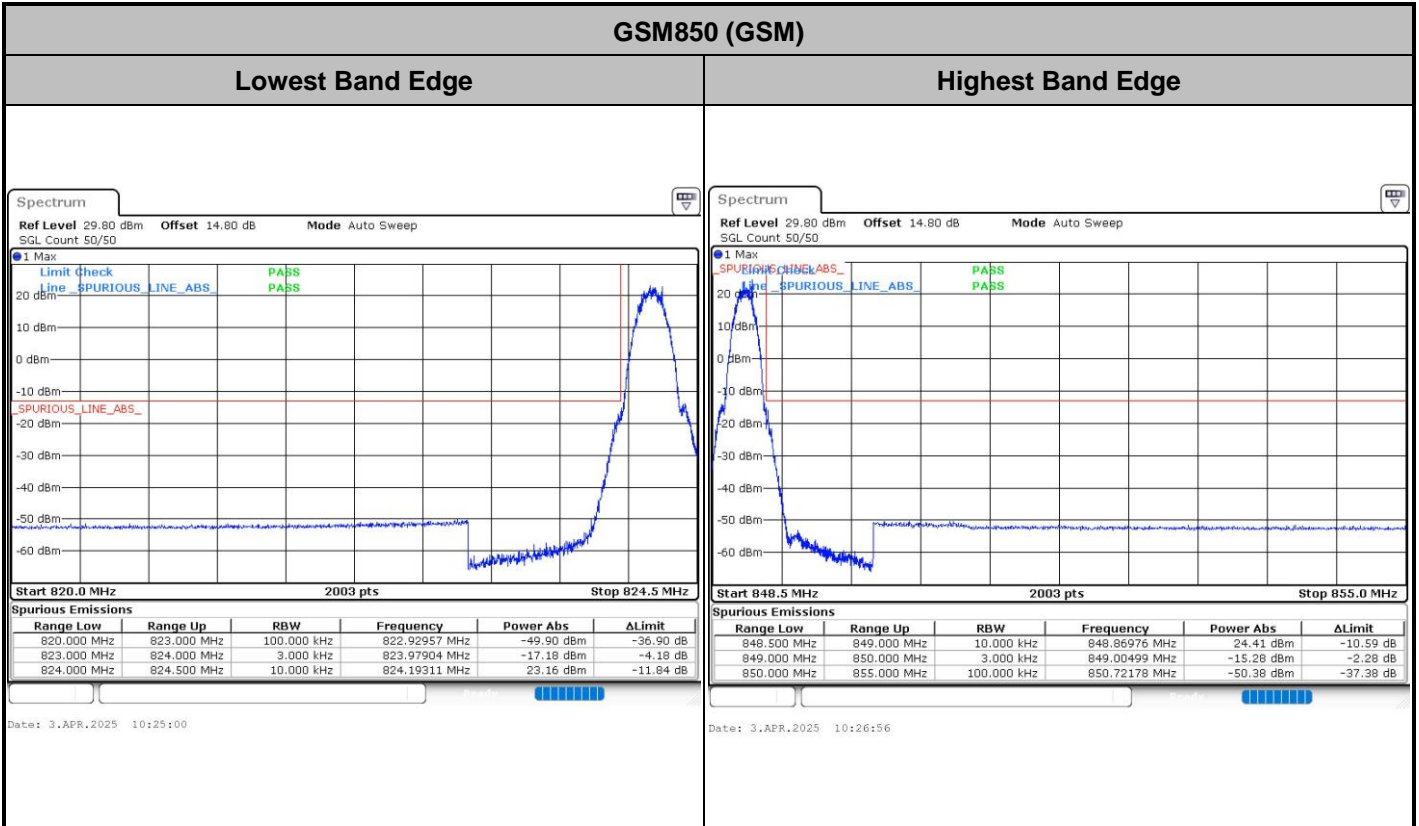



GSM1900 (GSM)

Lowest Band Edge

Highest Band Edge

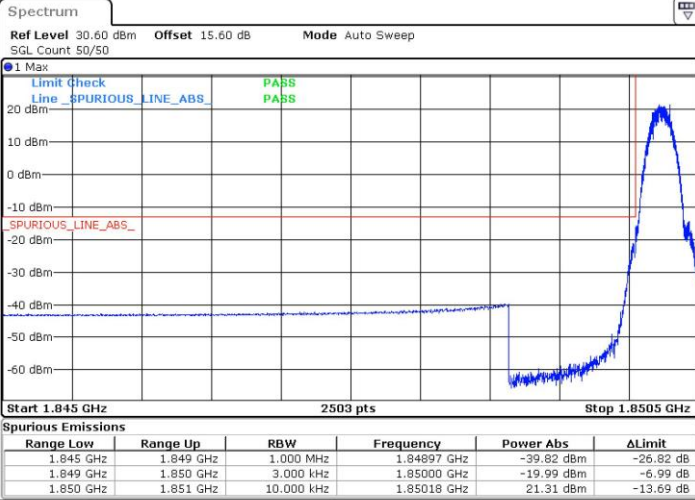

Date: 3.APR.2025 15:28:42

Date: 3.APR.2025 15:30:40

GSM1900 (EDGE class 8)

Lowest Band Edge

Highest Band Edge

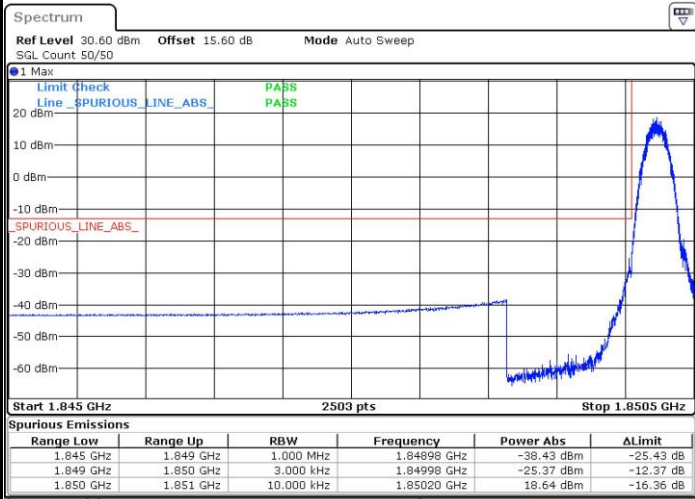

Date: 3.APR.2025 15:48:52

Date: 3.APR.2025 15:50:48



# Conducted Spurious Emission

## GSM850 (GSM)

### Lowest Channel

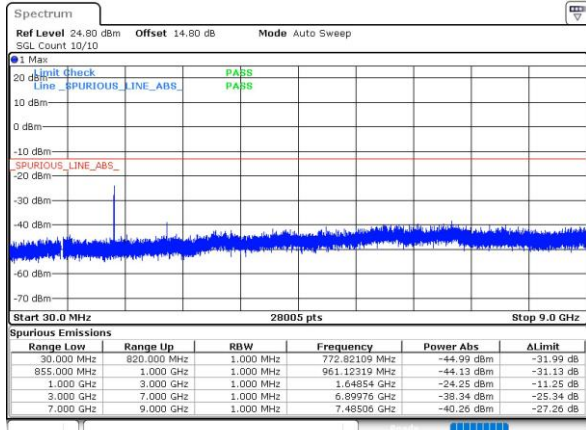

Date: 3.APR.2025 10:29:50

## GSM850 (EDGE class 8)

### Lowest Channel

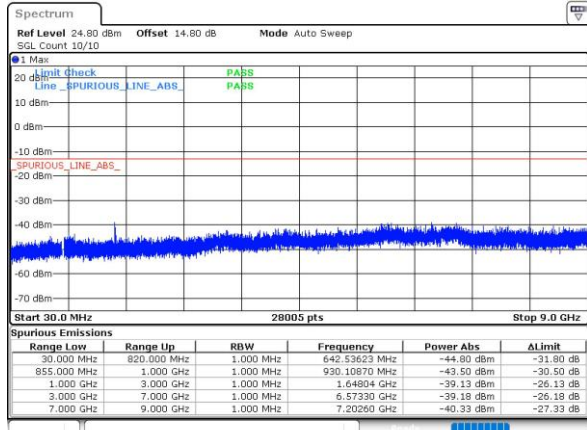

Date: 3.APR.2025 11:01:08

### Middle Channel

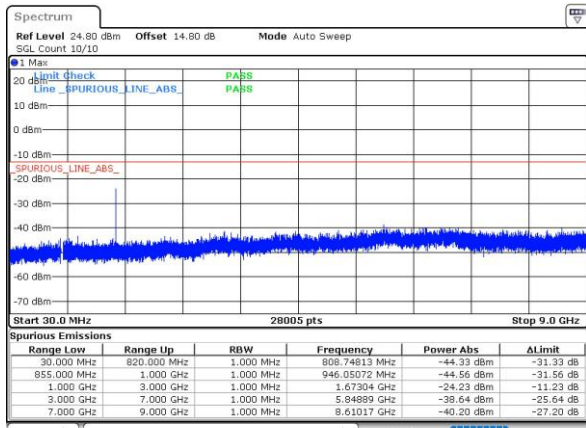

Date: 3.APR.2025 10:31:47

### Middle Channel

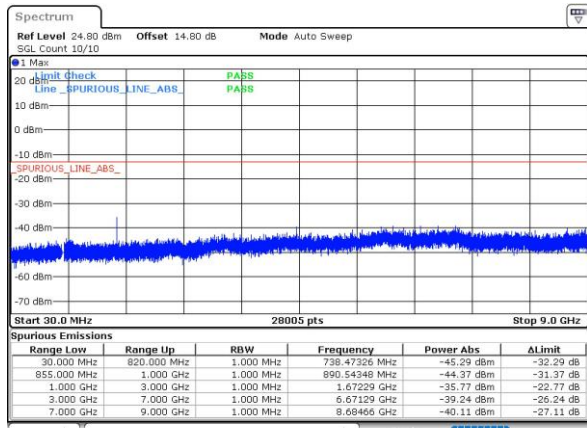

Date: 3.APR.2025 11:08:25

### Highest Channel

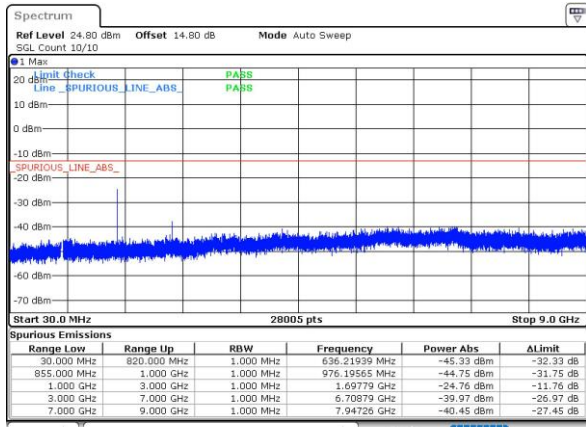

Date: 3.APR.2025 10:34:48

### Highest Channel

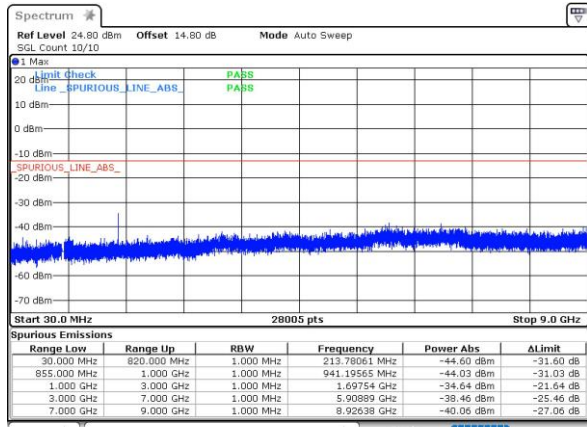

Date: 3.APR.2025 11:12:13



GSM1900 (GSM)

Lowest Channel

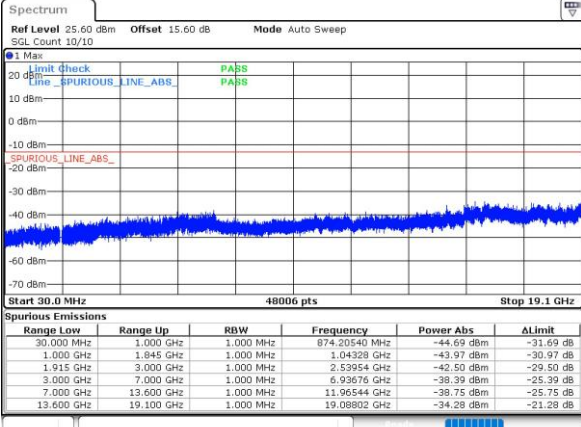

Date: 3.APR.2025 15:33:17

GSM1900 (EDGE class 8)

Lowest Channel

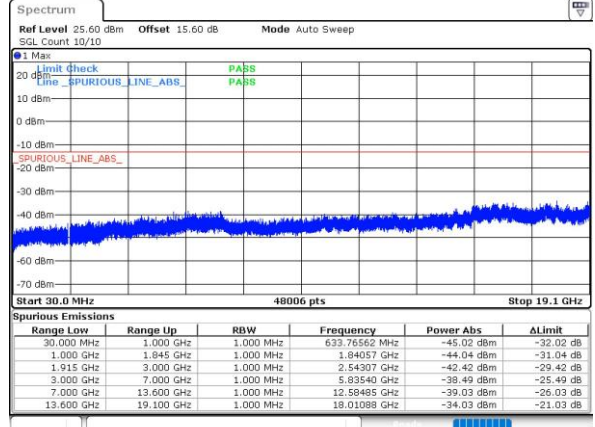

Date: 3.APR.2025 15:52:56

Middle Channel

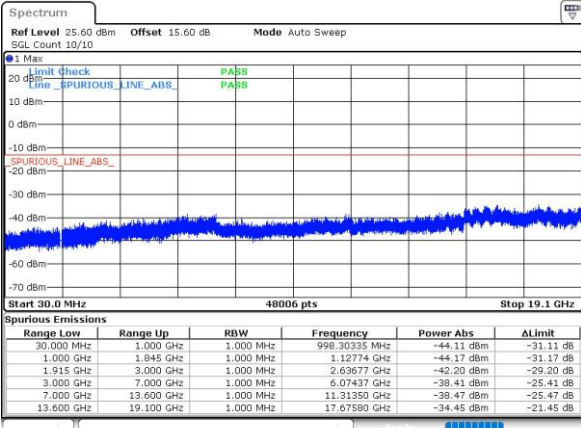

Date: 3.APR.2025 15:35:16

Middle Channel

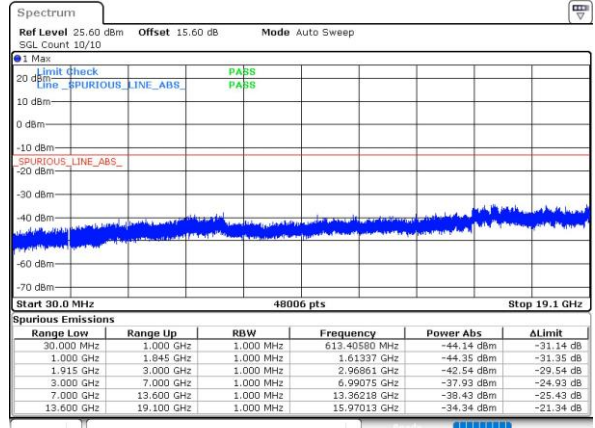

Date: 3.APR.2025 15:54:52

Highest Channel

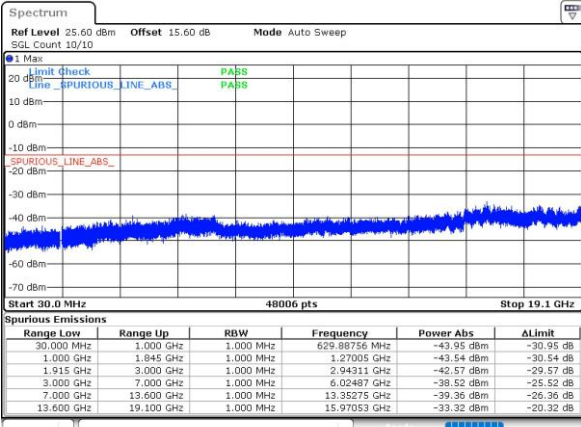

Date: 3.APR.2025 15:38:21

Highest Channel

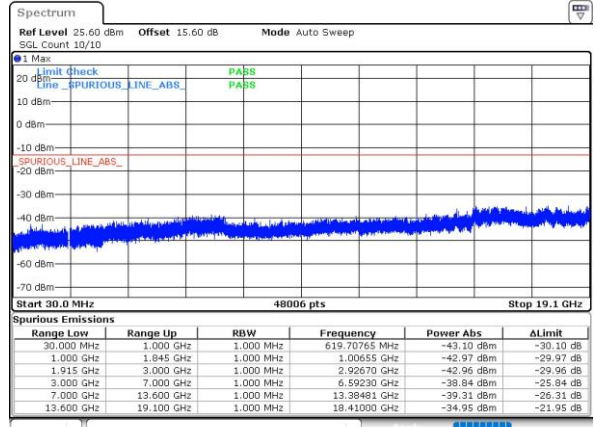

Date: 3.APR.2025 15:57:52



Frequency Stability

Test Conditions	Middle Channel	GSM850 (GSM)	GSM850 (EDGE class 8)	Limit 2.5ppm
Temperature (°C)	Voltage (Volt)	Deviation (ppm)		Result
50	Normal Voltage	0.0046	0.0078	PASS
40	Normal Voltage	0.0523	0.0116	
30	Normal Voltage	0.0579	0.0535	
20(Ref.)	Normal Voltage	0.0000	0.0000	
10	Normal Voltage	0.0432	0.0446	
0	Normal Voltage	0.0619	0.0127	
-10	Normal Voltage	0.0055	0.0463	
-20	Normal Voltage	0.0147	0.0138	
-30	Normal Voltage	0.0162	0.0469	
20	Maximum Voltage	0.0037	0.0734	
20	Normal Voltage	0.0128	0.0166	
20	Battery End Point	0.0943	0.0063	



Test Conditions	Middle Channel	GSM1900 (GSM)	GSM1900 (EDGE class 8)	Limit Note 2.
Temperature (°C)	Voltage (Volt)	Deviation (ppm)		Result
50	Normal Voltage	0.0049	0.0563	PASS
40	Normal Voltage	0.0051	0.0013	
30	Normal Voltage	0.0073	0.0024	
20(Ref.)	Normal Voltage	0.0000	0.0000	
10	Normal Voltage	0.0112	0.0268	
0	Normal Voltage	0.0034	0.0495	
-10	Normal Voltage	0.0162	0.0637	
-20	Normal Voltage	0.0277	0.0041	
-30	Normal Voltage	0.0269	0.0265	
20	Maximum Voltage	0.0048	0.0178	
20	Normal Voltage	0.0057	0.0033	
20	Battery End Point	0.0236	0.0029	

**Note:**

1. Normal Voltage = 3.81V ; Battery End Point (BEP) =3.4V.; Maximum Voltage =4.5V
2. The frequency fundamental emissions stay within the authorized frequency block.



## A2. WCDMA

### Peak-to-Average Ratio

Mode	WCDMA Band V	WCDMA Band II	WCDMA Band IV	Limit: 13dB
Mod.	RMC 12.2Kbps	RMC 12.2Kbps	RMC 12.2Kbps	Result
Lowest CH	3.16	2.81	2.61	<b>PASS</b>
Middle CH	2.99	2.96	2.38	
Highest CH	3.01	2.84	2.72	

