

PARTIAL FCC RADIO TEST REPORT

Name of Sample: Mobile Cellular Phone
Model of Sample: XT2527-2
Applicant: Motorola Mobility LLC
Issued Date: 2025-04-29



ADR TEST AND CERTIFICATION CENTER
Motorola Mobility LLC, a Lenovo Company

Add: No. 19, Gao Xin 4th Road Wuhan, People's Republic of China 430205

Phone: (86) 13696970830

E-mail: suyj3@motorola.com

Name of Client	Motorola Mobility LLC		
Address of Client	222 W, Merchandise Mart Plaza, Chicago IL 60654 USA		
Trademark	Motorola	Type Name or ID	IHDT56AV4
Applicant No.	RF190518	Sample No.	SN: NN0E230275
Delivering Date	2025-03-21	Test Date(s)	2025-04-14 to 2025-04-28
Sample Illustration	None		
Standard	47 CFR Part 2,22,27,90		
Conclusion	PASS		
Remarks	None		

Editor: Chuan Sun

Reviewer: Jianfeng Wen

Signatory: Eric Lin

Chuan Sun

Jianfeng Wen

Eric Lin

Matters Needing Attention

- a) The electronic report shall be valid after encryption.
- b) The paper report shall be valid after being stamped with the official seal of the company.
- c) The report is invalid without the signature of the Editor, Reviewer and Signatory.
- d) The test report is invalid if there is any evidence of erasure and/or falsification.
- e) If there is any dissidence for the test report, please file objection to the lab within 15 days from the date of receiving the test report.
- f) The test report is only responsible for the tested model/sample; the sample(s) presented in the report are provided by the Client.
- g) Context of the test report cannot be used partially or in full for publicity and/or promotional purposes without previous written approval of the lab.

REVISION HISTORY

REPORT NO.	VERSION	DESCRIP TION	ISSUED DATE
25ADRTCC5020	Rev. 01	Initial issue of report	2025-04-18
25ADRTCC5020	Rev. 02	1. Update product information and test set-up photo 2. Add test mode and reference report	2025-04-28
25ADRTCC5020	Rev. 03	Add reference report	2025-04-29
25ADRTCC5020	Rev. 04	Update 3.2 chapter	2025-04-29

Catalogue

1. Information Of Equipment Under Test(EUT)	5
2. Details Of Test	6
2.1 Applicant.....	6
2.2 Location of Test	6
2.3 Applied Standards.....	6
3. Re-use of Measured Data	7
3.1 Introduction Section	7
3.2 Model Difference Information	7
3.3 Spot Check Verification Data Section	7
3.4 Reference detail Section:.....	7
4. Result Summary	8
5. Tests Configuration Of EUT.....	9
5.1 EUT Test Modes.....	9
5.2 Configuration Of Test System.....	10
5.3 Support Unit For Test.....	10
6. Test Description.....	11
6.1 Radiated spurious emissions.....	11
6.1.1 Limit	11
6.1.2 Test Procedure.....	11
6.1.3 Test Results	13
7. Test Equipment And Software	14
8. System Measurement Uncertainty	14
8.1 RSE.....	15
9. EUT And Test Set-up Photos.....	18
9.1 EUT	18
9.2 Test Set-up	19
10. Reference report.....	20

1. Information Of Equipment Under Test(EUT)

Product Name:	Mobile Cellular Phone		
Brand Name:	Motorola		
Model Name:	XT2527-2		
FCC ID:	IHDT56AV4		
Software Version:	V2VN35.50		
Hardware Version:	DVT2		
IMEI Code:	358674600016596 / 358674600016604 for Sample 1		
Supports Radio application in this standard:			
5G NR	n5/n26/n71/n77/n78/n7/n38/n41		
ENDC Combos	DC_7A_n5A	DC_5A_n41A	DC_7A_n77A
	DC_5A_n78A	DC_7A_n78A	DC_41A_n78A
	DC_38A_n78A		
Accessory			
Product	Brand	model	
AC Adapter 1(US)	Motorola (Salcomp)	MC-331L	
AC Adapter 1(EU)	Motorola (Salcomp)	MC-332L	
AC Adapter 1(UK)	Motorola (Salcomp)	MC-333L	
AC Adapter 1(AU)	Motorola (Salcomp)	MC-335L	
AC Adapter 1(AR)	Motorola (Salcomp)	MC-336L	
AC Adapter 1(BR)	Motorola (Salcomp)	MC-337L	
AC Adapter 2(US)	Motorola (Chenyang)	MC-331L	
AC Adapter 2(EU)	Motorola (Chenyang)	MC-332L	
AC Adapter 2(UK)	Motorola (Chenyang)	MC-333L	
AC Adapter 2(AR)	Motorola (Chenyang)	MC-336L	
AC Adapter 2(BR)	Motorola (Chenyang)	MC-337L	
Battery 1	NVT	RA52	
Battery 2	SUNWODA	RA52	
Earphone 1	Juwei	ZN80400118H001	
USB Cable 1	Washin	HX-ZN-34	
USB Cable 2	Juwei	JWUB1928-ZN01H	

Remark:

1. The EUT's information was declared by manufacturer. Please refer to the manufacturer's specifications or user's manual for more detailed description.
2. This partial report only includes 5G NR RSE test data, 5G NR other test cases are shown separately.

2. Details Of Test

2.1 Applicant

Applicant Name:	Motorola Mobility LLC
Address:	222 W, Merchandise Mart Plaza, Chicago IL 60654 USA

2.2 Location of Test

Test Site 1:	ADR TEST AND CERTIFICATION CENTER
Address:	NO.19, Gao Xin 4 th Road, Wuhan, 430205, P.R China

2.3 Applied Standards

According to the specifications of the manufacturer, the EUT must comply with the requirements of the following standards:

47 CFR Part 2,22,27,90

ANSI C63.26-2015

FCC KDB 971168 D01 Power Meas License Digital Systems v03r01

FCC KDB 412172 D01 Determining ERP and EIRP v01r01

FCC KDB 484596 D01 Referencing Test Data v02r02

3. Re-use of Measured Data

3.1 Introduction Section

This application re-uses data collected on a similar device. The subject device of this application (Model: XT2527-2, FCC ID: IHDT56AV4) is electrically identical to the reference device (Model: XT2527-1, FCC ID: IHDT56AV5) for the portions of the circuitry corresponding to the data being re-used. Based on their similarity. The FCC Part 22,27,90 referencing the original model’s result and do spot check, following the FCC KDB484596 D01 Referencing Test Data v02r02.

The applicant takes full responsibility that the test data as referenced in this report represent compliance for this FCC ID: IHDT56AV4.

3.2 Model Difference Information

The main difference between FCC ID: IHDT56AV4 and FCC ID: IHDT56AV5 is as below:

- Remove WCDMA B4, LTE B4/12/13/17/25/66 and 5G NR n2/n66.
- Add LTE B20/32/71/38C/41C and 5G NR n8/n20/n71.
- B41/B41C/n77/n78 Enable PC2 by software.
- Add NSA mode for 5G NR n5/n77.

Other differences and all the details of similarity and difference can be found in the confidential documents (XT2527-1, XT2527-2_Operational Description of Product Equality Declaration).

3.3 Spot Check Verification Data Section

Test Item	Mode	Worst Mode Test Result		Deviation (dB)	Limit (dB)
		IHDT56AV5	IHDT56AV4		
Radiated spurious emission	n41	-8.49	-9.62	1.13	3

Conclusion:

Radiated spurious emission test against the variant model based on the worst-case condition from the original model was performed in this filing to demonstrate the test data from the original model remains representative for the variant model. Based on the spot check test result, the test data from the original model is representative for the variant model. All spot check test data are shown within expected level compliant to limit line.

3.4 Reference detail Section:

Rule Part	Equipment Class	Frequency Band (MHz)	Reference FCC ID (Parent)	Type Grant/ Permissive Change	Reference Title	FCC ID Filing (Variant)	Report Title/Section
22,27,90	PCE (NR)	N5/N7/N26/N38	IHDT56AV5	Original Grant	25ADRTCC5019	IHDT56AV4	All sections applicable

4. Result Summary

FCC Rule	Description	Limit	Result (PASS/FAIL)	Remark
§ 2.1053 § 27.53(g) § 27.53(l) (2)	Radiated Spurious Emission (5G NR n71) (5G NR n77) (5G NR n78)	$< 43+10\log_{10}(P[\text{Watts}])$	PASS	-
§ 2.1053 § 27.53(m)(4)	Radiated Spurious Emission (5G NR n41)	$< 55+10\log_{10}(P[\text{Watts}])$	PASS	-

decision rules: Statements of conformity (e.g., Pass/Fail) to specifications are made in this report without taking measurement uncertainty into account except when requested by the customer. Where statements of conformity are made in this report, the following decision rules are applied:

- PASS- Results within limits/specifications
- FAIL- Results exceed limits/specifications

Remark:

1. For the test result, the EUT had been tested with all test modes. But only the worst case was shown in test report.
2. 5G NR n77 cover n78

Summary of Environment Condition, Test Date and Test Engineer for all Test Items

Test items	Ambient Temperature (°C)	Relative Humidity (%)	Test Date	Test Engineer
Radiated spurious emissions	25-26	42-45	Apr.14, 2025~ Apr.28, 2025	Man Cao Mingzhu Li Chuanghui xiao



5. Tests Configuration Of EUT

5.1 EUT Test Modes

Antenna port conducted and radiated test items are performed according to KDB 971168 D01 Power Meas License Digital Systems v03r01 with maximum output power.

For radiated measurement, pre-scanned in three orthogonal panels, X, Y, Z. The worst cases (Y plane) were recorded in this report.

The device is investigated from 30MHz to 10 times of fundamental signal for radiated spurious emission test under different RB size/offset and modulations in exploratory test. Subsequently, only worst case emissions are reported.

	X Plane	Y Plane	Z Plane
Orthogonal Planes of EUT			

5G SA

Cases	Ant.	Band	Channel	configuration
1	1	n41	M	QPSK, BW 100MHz, RB Size 1, RB Offset 1
2	0	n71	M	QPSK, BW 20MHz, RB Size 1, RB Offset 1
3	5	n77	M	QPSK, BW 100MHz, RB Size 1, RB Offset 1

5G NSA (ENDC Combos)

Cases	Ant.	Band	Channel		configuration	
			LTE	5GNR	LTE	5GNR
1	1+5	7A+n77A	M	M	QPSK, BW 20MHz, RB Size 1, RB Offset 0	QPSK, BW 100MHz, RB Size 1, RB Offset 1
2	0+5	5A+n78A	M	M	QPSK, BW 10MHz, RB Size 1, RB Offset 0	QPSK, BW 100MHz, RB Size 1, RB Offset 1

Remark:

1. If there is over one kind of accessories, each one should be applied in all the test modes.
2. All the supported SA and NSA(EN-DC) combinations are verified RSE, only the worse cases are shown in the report.
3. The NSA(EN-DC) combination could be referred to the product spec.
4. All the cases will be tested the Traffic Mode.

Traffic Mode: When the EUT state is switched on and with Radio Resource Control (RRC)

connection established.

- Pre-scanned harmonic for the different antenna combinations, we choose the worst antenna mode to perform final test. Only the worst case will be recorded in this report.

5.2 Configuration Of Test System

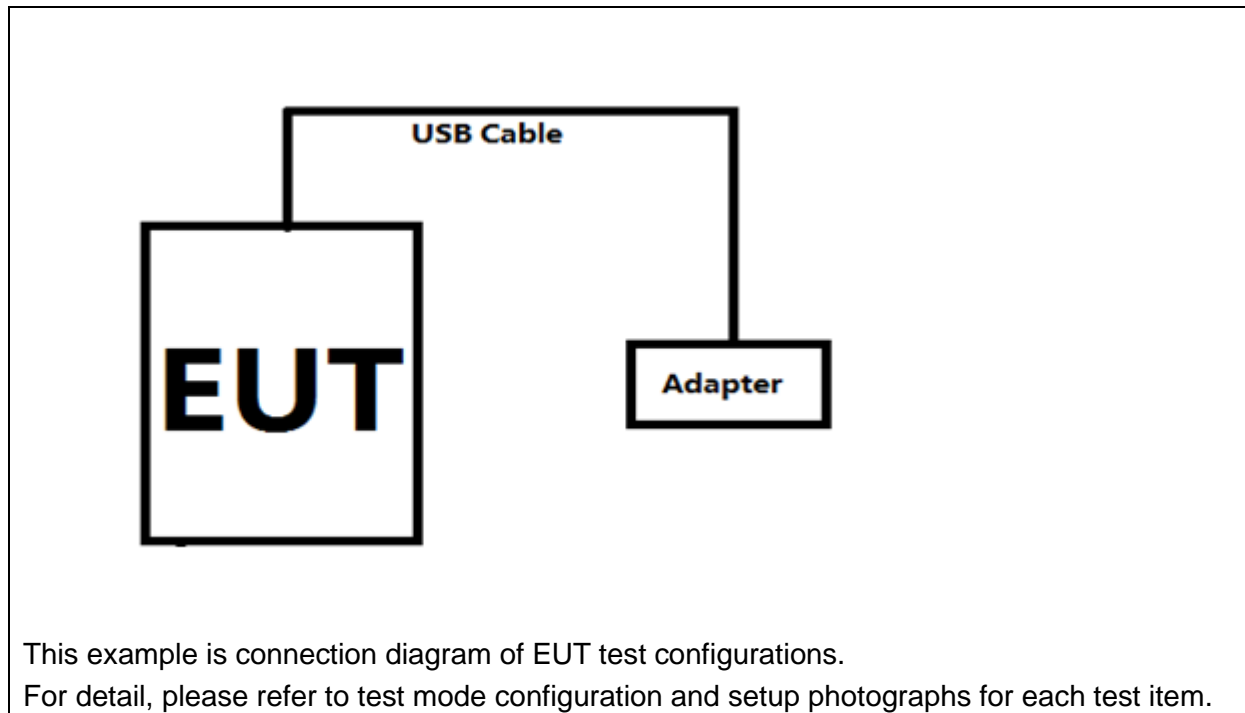

5.3 Support Unit For Test

Name	Model Name	Manufacturer	S/N
System Simulator	CMX500	R&S	102510

6. Test Description

6.1 Radiated spurious emissions

6.1.1 Limit

Based on 47 CFR Part 22,27,90, the RF fundamental frequency should be excluded against the limit line in the operating frequency band.

The limit line example:

$$43 + 10\log(P)\text{dB below the transmitter power } P(\text{Watts})$$

$$= P(\text{W}) - [43 + 10\log(P)] (\text{dB})$$

$$= [30 + 10\log(P)] (\text{dBm}) - [43 + 10\log(P)] (\text{dB})$$

$$= -13\text{dBm.}$$

6.1.2 Test Procedure

1. The testing follows ANSI C63.26 Section 5.5.
2. The EUT was placed on a turntable with 0.8 meter height for frequency below 1GHz and 1.5 meter height for frequency above 1GHz respectively above ground.
3. The EUT was set 3 meters from the receiving antenna mounted on the antenna tower.
4. The table was rotated 360 degrees to determine the position of the highest spurious emission.
5. The height of the receiving antenna is varied between 1m to 4m to search the maximum spurious emission for both horizontal and vertical polarizations.
6. During the measurement, the system simulator parameters were set to force the EUT transmitting at maximum output power.
7. Make the measurement with the spectrum analyzer's RBW=100kHz(30M~1GHz) or 1MHz(above 1GHz), VBW=300kHz(30M~1GHz) or 1MHz(above 1GHz), taking the record of maximum spurious emission.
8. Radiated measurement using the Field Strength Method. Using the test configuration shown in 5.1.3. We measure the radiated emissions directly from the EUT and convert the measured field strength or received power to ERP or EIRP, as required, for comparison to the applicable limits. As stated in 5.5.1 of ANSI C63.26-2015, the field strength measurement method using a test site validated to the requirements of ANSI C63.4 is an alternative to the substitution measurement method.
9. Radiated Power Measurement Calculation According to ANSI C63.26-2015.
 - a) $E (\text{dB}\mu\text{V}/\text{m}) = \text{Measured amplitude level (dB}\mu\text{V}) + \text{Cable Loss (dB)} + \text{Antenna Factor (dB/m)}$.
 - b) $E (\text{dB}\mu\text{V}/\text{m}) = \text{Measured amplitude level (dBm)} + 107 + \text{Cable Loss (dB)} + \text{Antenna Factor (dB/m)}$.
 - c) $E (\text{dB}\mu\text{V}/\text{m}) = \text{EIRP (dBm)} - 20\log(D) + 104.8$; where D is the measurement distance (in the far field region) in m.
 - d) $\text{EIRP (dBm)} = E (\text{dB}\mu\text{V}/\text{m}) + 20\log(D) - 104.8$; where D is the measurement distance (in the far field region) in m.

So, from d)

The measuring distance is usually at 3m, then $20*\text{Log}(3)=9.5424$.

Then, $\text{EIRP (dBm)} = E (\text{dB}\mu\text{V}/\text{m}) + 9.5424 - 104.8 = E (\text{dB}\mu\text{V}/\text{m}) - 95.2576$.
10. If the emission level of the EUT in PEAK measurement mode was 3 dB lower than the limit specified, peak values of EUT will be reported. Otherwise, the level will be measured by using the RMS mode and reported.

Test Set-up

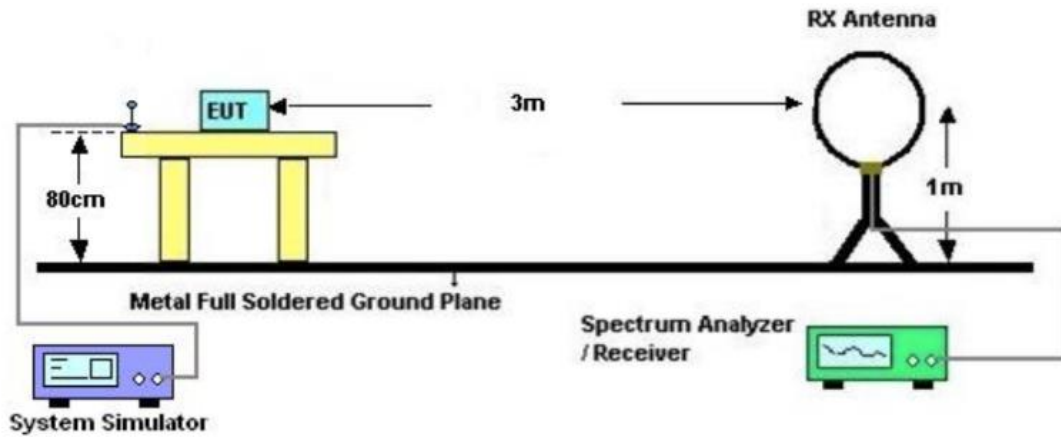

Figure.1 Test set-up of radiated emissions (Below 30MHz)

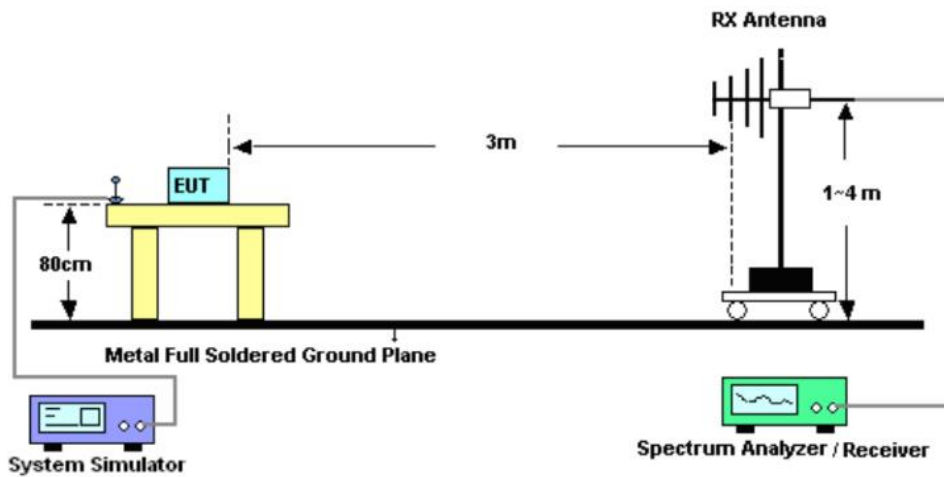

Figure.2 Test set-up of radiated emissions (30MHz~1GHz)

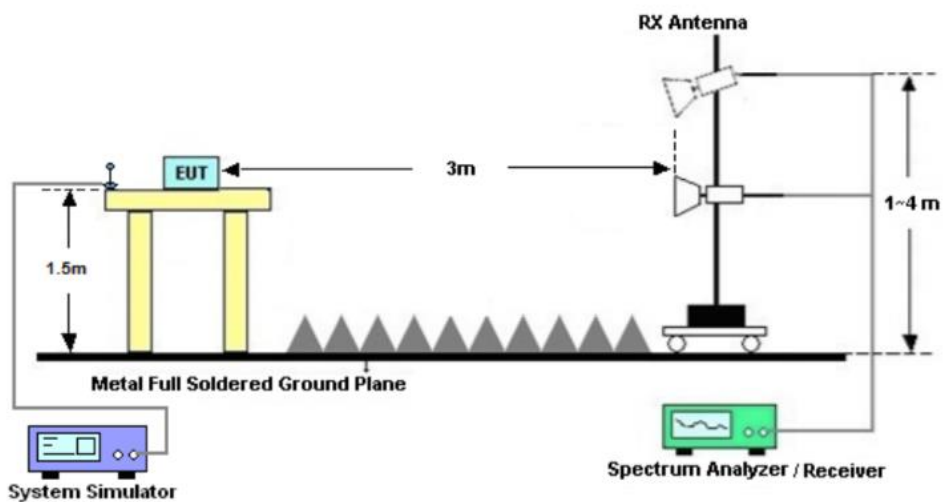

Figure.3 Test set-up of radiated emissions (above 1GHz)

6.1.3 Test Results

The EUT has met the requirements.

Test data refer to the section 8.1 of this report.

Only the worst test result was shown in this report.

Only the plots of the worst case are shown in this report.

The low frequency, which started from 9 kHz to 30MHz, was pre-scanned and the result which was 20dB lower than the limit line was not reported.

The data example:

Channel	Frequency (MHz)	EIRP (dBm)	Limit (dBm)	Over Limit (dB)	Correction [dB]	Detector	Polarization (H/V)
M	2014	-25.63	-13.00	-12.63	19.36	PK	H

Correction = Antenna factor + Cable loss – Preamplifier gain

E (dBuV/m) = Reading level + Correction

The measuring distance is 3m, then

EIRP= E (dBuV/m) - 95.26= Reading level + Correction- 95.26= Reading level+ Antenna factor + Cable loss – Preamplifier gain- 95.26

Over Limit = EIRP – Limit

Note: Reading level/ Antenna factor /Cable loss /Preamplifier gain are calculated by software background and are not shown in the data sheet.

7. Test Equipment And Software

Main Test Equipment						
Test items	Instrument	Manufacturer	Model No.	Serial No.	Calibration Date	Calibration interval(year)
RSE	Log-per.-Antenna	R&S	VULB9163	9163-893	2024/01/19	2
	Double Ridged Horde Antenna	R&S	HF907	100545	2025/02/10	3
	Double Ridged Horde Antenna	R&S	QWH-SL-18-40-K-SG	12004	2025/02/10	3
	Loop Antenna	R&S	FMZB	1513	2024/04/23	3
	EMI Test Receiver (Below30MHz /30M~1GHz)	R&S	ESR7	101188	2024/07/08	1
	Signal Analyzer (Above 1GHz)	R&S	FSV40	100956	2024/11/13	1
	SAC	ETS	/	5582	2025/01/15	3
	Turn Table	ETS	TT	2090	/	/
	Maturo NCA	Maturo	NCDv2.0	/	/	/
	Antenna Mast	Maturo	BAM 4.0-P	92536	/	/
	SCU18F	R&S	/	101084	/	/
	SCU40H48M	R&S	/	100250	/	/
	OSP	R&S	B155G	100852	/	/
Remark: OSP(B155G) is an integrated system of amplifiers and attenuators, for the frequency range of 1G -18 GHz, and during measurement the internal path will be switched to the appropriate amplifier and attenuator corresponding to frequencies to be measured. The complete system frequency response is verified prior to the measurement.						
Software Information						
Test Item	Software Name			Version		
RSE	ELEKTRA			V5.05.0		

8. System Measurement Uncertainty

The measurement uncertainties shown below were calculated in accordance with the requirements of ANSI 63.26-2015. All the measurement uncertainty value were shown with a coverage K=2 to indicate 95% level of confidence. The measurement data show herein meets or exceeds the CISPR measurement uncertainty values specified in CISPR 16-4-2 and can be compared directly to specified limit to determine compliance.

Measurement Uncertainty	
Items	Extended Uncertainty
RSE(30MHz~1GHz)	U=5.9dB; k=2
RSE(1GHz~18GHz)	U=5.0dB; k=2
RSE(18GHz-40GHz)	U=5.1dB; k=2

Test Data

8.1 RSE

Worse plot(N71 SA)

1G-18G H

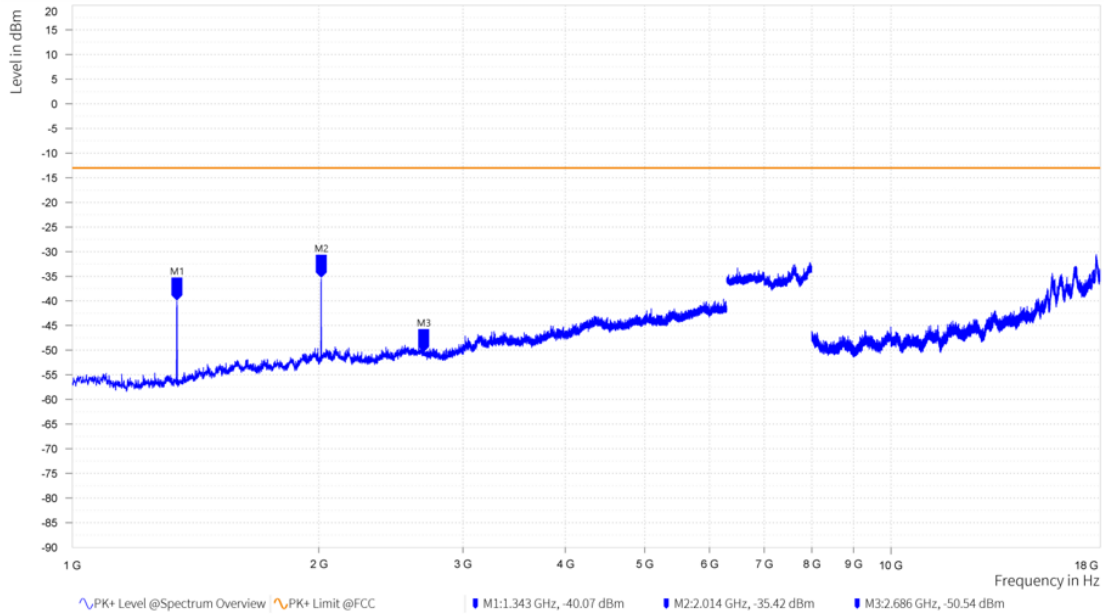

1G-18G V

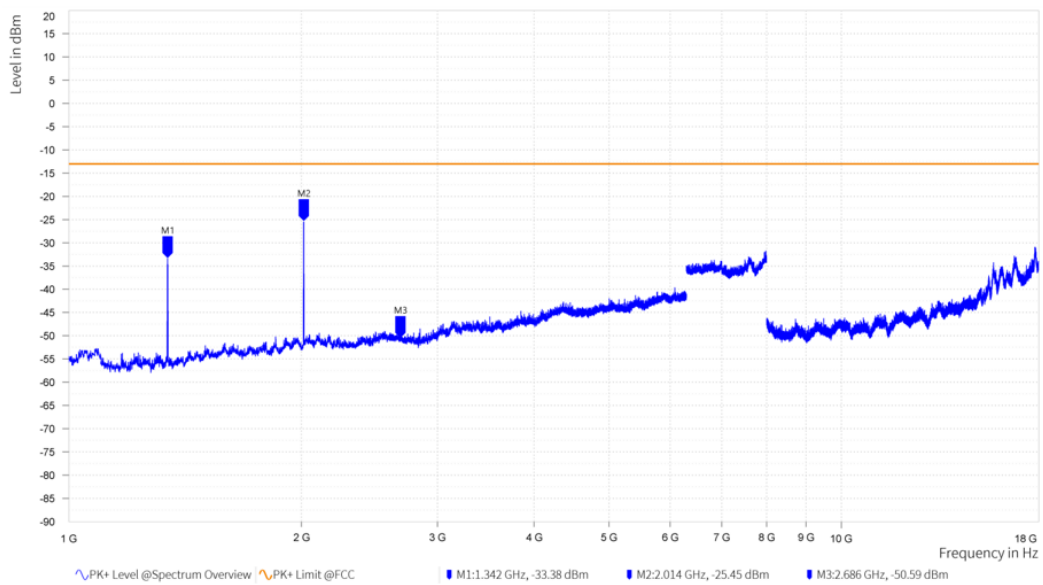

Data Table

N41 SA							
Channel	Frequency (MHz)	EIRP (dBm)	Limit (dBm)	Over Limit (dB)	Correction [dB]	Detector	Polarization (H/V)
Middle	5089	-43.91	-25.00	-18.91	29.05	PK	H
	7633	-34.62	-25.00	-9.62	39.25	PK	H
	10178	-48.12	-25.00	-23.12	26.51	PK	H
	5089	-43.04	-25.00	-18.04	29.03	PK	V
	7633	-34.80	-25.00	-9.80	39.27	PK	V
	10178	-48.12	-25.00	-23.12	26.53	PK	V

Remark: Spurious emissions within 30-1000MHz were found more than 20dB below limit line.

N71 SA							
Channel	Frequency (MHz)	EIRP (dBm)	Limit (dBm)	Over Limit (dB)	Correction [dB]	Detector	Polarization (H/V)
Middle	1342	-39.99	-13.00	-26.99	24.23	PK	H
	2014	-35.42	-13.00	-22.42	28.92	PK	H
	2686	-50.54	-13.00	-37.54	37.06	PK	H
	1342	-33.33	-13.00	-20.33	12.47	PK	V
	2014	-25.63	-13.00	-12.63	19.36	PK	V
	2686	-50.57	-13.00	-37.57	20.98	PK	V

Remark: Spurious emissions within 30-1000MHz were found more than 20dB below limit line.

N77 SA							
Channel	Frequency (MHz)	EIRP (dBm)	Limit (dBm)	Over Limit (dB)	Correction [dB]	Detector	Polarization (H/V)
Middle	7583	-34.20	-13.00	-21.20	38.99	PK	H
	11374	-44.04	-13.00	-31.04	27.26	PK	H
	15168	-42.21	-13.00	-29.21	32.42	PK	H
	7583	-34.80	-13.00	-21.80	39.00	PK	V
	11374	-44.45	-13.00	-31.45	27.26	PK	V
	15168	-42.15	-13.00	-29.15	32.42	PK	V

Remark: Spurious emissions within 30-1000MHz were found more than 20dB below limit line.

DC_7A_n77A							
Channel	Frequency (MHz)	EIRP (dBm)	Limit (dBm)	Over Limit (dB)	Correction [dB]	Detector	Polarization (H/V)
Middle	7583	-34.54	-13.00	-21.54	38.99	PK	H
	11374	-46.60	-13.00	-33.60	27.26	PK	H
	15166	-41.33	-13.00	-28.33	32.42	PK	H
	7583	-35.86	-13.00	-22.86	37.06	PK	V
	11374	-49.34	-13.00	-36.34	25.97	PK	V
	15166	-44.52	-13.00	-31.52	30.88	PK	V

Remark: Spurious emissions within 30-1000MHz were found more than 20dB below limit line.

DC_5A_n78A							
Channel	Frequency (MHz)	EIRP (dBm)	Limit (dBm)	Over Limit (dB)	Correction [dB]	Detector	Polarization (H/V)
Middle	7402	-35.94	-13.00	22.94	37.97	PK	H
	11103	-49.92	-13.00	36.92	27.26	PK	H
	14804	-44.40	-13.00	31.40	32.26	PK	H
	7402	-36.41	-13.00	23.41	37.96	PK	V
	11103	-49.63	-13.00	36.63	27.26	PK	V
	14804	-44.18	-13.00	31.18	32.26	PK	V

Remark: Spurious emissions within 30-1000MHz were found more than 20dB below limit line.

10. Reference report

PARTIAL FCC RADIO TEST REPORT

Name of Sample: Mobile Cellular Phone
Model of Sample: XT2527-1
Applicant: Motorola Mobility LLC
Issued Date: 2025-04-25



ADR TEST AND CERTIFICATION CENTER
Motorola Mobility LLC, a Lenovo Company

Add: No. 19, Gao Xin 4th Road Wuhan, People's Republic of China 430205

Phone: (86) 13696970830

E-mail: suyj3@motorola.com

Name of Client	Motorola Mobility LLC		
Address of Client	222 W, Merchandise Mart Plaza, Chicago IL 60654 USA		
Trademark	Motorola	Type Name or ID	IHDT56AV5
Applicant No.	RF190514	Sample No.	SN: NNOR210382
Delivering Date	2025-03-17	Test Date(s)	2025-04-03 to 2025-04-14
Sample Illustration	None		
Standard	47 CFR Part 2,22,24,27,90		
Conclusion	PASS		
Remarks	None		

Editor: Chuan Sun

Reviewer: Jianfeng Wen

Signatory: Eric Lin

Chuan Sun

Jianfeng Wen

Eric Lin

Matters Needing Attention

- h) The electronic report shall be valid after encryption.
- i) The paper report shall be valid after being stamped with the official seal of the company.
- j) The report is invalid without the signature of the Editor, Reviewer and Signatory.
- k) The test report is invalid if there is any evidence of erasure and/or falsification.
- l) If there is any dissidence for the test report, please file objection to the lab within 15 days from the date of receiving the test report.
- m) The test report is only responsible for the tested model/sample; the sample(s) presented in the report are provided by the Client.
- n) Context of the test report cannot be used partially or in full for publicity and/or promotional purposes without previous written approval of the lab.

REVISION HISTORY

REPORT NO.	VERSION	DESCRIP TION	ISSUED DATE
25ADRTCC5019	Rev. 01	Initial issue of report	2025-04-16
25ADRTCC5019	Rev. 02	Added product band information	2025-04-24
25ADRTCC5019	Rev. 03	Update table format,	2025-04-25
25ADRTCC5019	Rev. 04	Update test setup	2025-04-25

Catalogue

1.	Information Of Equipment Under Test(EUT)	25
2.	Details Of Test	26
2.1	Applicant.....	26
2.2	Location of Test	26
2.3	Applied Standards.....	26
3.	Result Summary	27
4.	Tests Configuration Of EUT.....	28
4.1	EUT Test Modes.....	28
4.2	Configuration Of Test System.....	30
4.3	Support Unit For Test.....	30
5.	Test Description.....	31
5.1	Radiated spurious emissions.....	31
5.1.1	Limit	31
5.1.2	Test Procedure.....	31
5.1.3	Test Results	33
6.	Test Equipment And Software	34
7.	System Measurement Uncertainty	34
7.1	RSE.....	35
8.	EUT And Test Set-up Photos.....	42
8.1	EUT	42
8.2	Test Set-up.....	43

1. Information Of Equipment Under Test(EUT)

Product Name:	Mobile Cellular Phone		
Brand Name:	Motorola		
Model Name:	XT2527-1		
FCC ID:	IHDT56AV5		
Software Version:	V2VN35.50		
Hardware Version:	DVT2		
IMEI Code:	358887330039692/358887330039700 for Sample 1		
Supports Radio application in this standard:			
5G NR	n2/n5/n7/n26/n38/n41/n66/n77/n78		
ENDC Combos	DC_2A_n7A	DC_4A_n7A	DC_5A_n7A
	DC_2A_n66A	DC_5A_n66A	DC_7A_n66A
	DC_66A_n41A	DC_2A_n78A	DC_4A_n78A
	DC_5A_n78A	DC_7A_n78A	DC_38A_n78A
	DC_41A_n78A	DC_66A_n78A	DC_26A_n78A
	DC_4A_n2A	DC_4A_n38A	DC_4A_n41A
	DC_66A_n38A	DC_66A_n7A	
Accessory			
Product	Brand	model	
AC Adapter 1(US)	Motorola (Salcomp)	MC-331L	
AC Adapter 1(EU)	Motorola (Salcomp)	MC-332L	
AC Adapter 1(UK)	Motorola (Salcomp)	MC-333L	
AC Adapter 1(AU)	Motorola (Salcomp)	MC-335L	
AC Adapter 1(AR)	Motorola (Salcomp)	MC-336L	
AC Adapter 1(BR)	Motorola (Salcomp)	MC-337L	
AC Adapter 2(US)	Motorola (Chenyang)	MC-331L	
AC Adapter 2(EU)	Motorola (Chenyang)	MC-332L	
AC Adapter 2(UK)	Motorola (Chenyang)	MC-333L	
AC Adapter 2(AR)	Motorola (Chenyang)	MC-336L	
AC Adapter 2(BR)	Motorola (Chenyang)	MC-337L	
Battery 1	NVT	RA52	
Battery 2	SUNWODA	RA52	
USB Cable 1	Washin	HX-ZN-34	
USB Cable 2	Juwei	JWUB1928-ZN01H	
Wireless Earphones	Motorola	XT2443-1	

Remark:

- The EUT's information was declared by manufacturer. Please refer to the manufacturer's specifications or user's manual for more detailed description.
- This partial report only includes 5G NR RSE test data, 5G NR other test cases are shown separately.

2. Details Of Test

2.1 Applicant

Applicant Name:	Motorola Mobility LLC
Address:	222 W, Merchandise Mart Plaza, Chicago IL 60654 USA

2.2 Location of Test

Test Site 1:	ADR TEST AND CERTIFICATION CENTER
Address:	NO.19, Gao Xin 4 th Road, Wuhan, 430205, P.R China

2.3 Applied Standards

According to the specifications of the manufacturer, the EUT must comply with the requirements of the following standards:

47 CFR Part 2,22,24,27,90

ANSI C63.26-2015

FCC KDB 971168 D01 Power Meas License Digital Systems v03r01

FCC KDB 412172 D01 Determining ERP and EIRP v01r01

3. Result Summary

FCC Rule	Description	Limit	Result (PASS/FAIL)	Remark
§ 2.1053 § 22.917(a) § 24.238(a) § 27.53(h) § 27.53(n)(2) § 90.691	Radiated Spurious Emission (5G NR n5, n26) (5G NR n2) (5G NR n66) (5G NR n77) (5G NR n78)	$< 43+10\log_{10}(P[\text{Watts}])$	PASS	-
§ 2.1053 § 27.53(m)(4)	Radiated Spurious Emission (5G NR n7, n38, n41)	$< 55+10\log_{10}(P[\text{Watts}])$	PASS	-

decision rules: Statements of conformity (e.g., Pass/Fail) to specifications are made in this report without taking measurement uncertainty into account except when requested by the customer. Where statements of conformity are made in this report, the following decision rules are applied:
 PASS- Results within limits/specifications
 FAIL- Results exceed limits/specifications

Remark:

- 3. For the test result, the EUT had been tested with all test modes. But only the worst case was shown in test report.
- 4. 5G NR n77 cover n78, n26 cover n5

Summary of Environment Condition, Test Date and Test Engineer for all Test Items

Test items	Ambient Temperature (°C)	Relative Humidity (%)	Test Date	Test Engineer
Radiated spurious emissions	23-26	40-45	Apr.03, 2025~ Apr.14, 2025	Man Cao Mingzhu Li Chuanghui xiao

4. Tests Configuration Of EUT

4.1 EUT Test Modes

Antenna port conducted and radiated test items are performed according to KDB 971168 D01 Power Meas License Digital Systems v03r01 with maximum output power.

For radiated measurement, pre-scanned in three orthogonal panels, X, Y, Z. The worst cases (Y plane) were recorded in this report.

The device is investigated from 30MHz to 10 times of fundamental signal for radiated spurious emission test under different RB size/offset and modulations in exploratory test. Subsequently, only worst case emissions are reported.

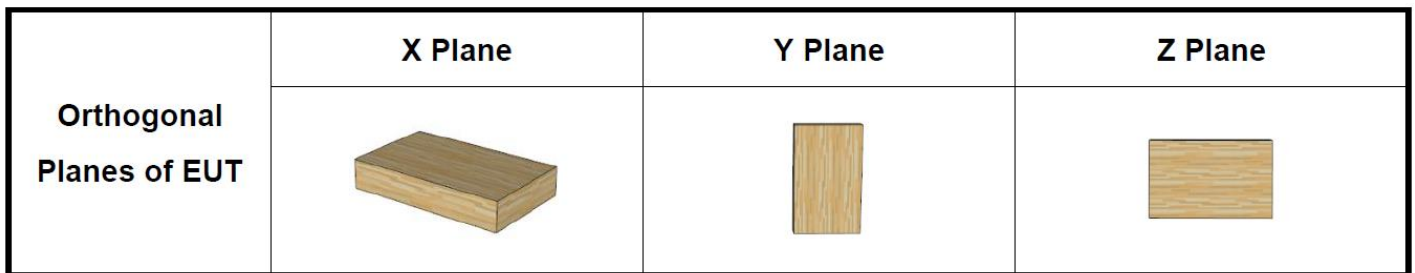

5G SA

Cases	Ant.	Band	Channel	configuration
1	1	n2	M	QPSK, BW 40MHz, RB Size 1, RB Offset 1
2	1	n7	M	QPSK, BW 50MHz, RB Size 1, RB Offset 1
3	0	n26 (Part 22)	M	QPSK, BW 20MHz, RB Size 1, RB Offset 1
4	0	n26 (Part 90)	M	QPSK, BW 20MHz, RB Size 1, RB Offset 1
5	1	n38	M	QPSK, BW 40MHz, RB Size 1, RB Offset 1
6	1	n41	M	QPSK, BW 100MHz, RB Size 1, RB Offset 1
7	1	n66	M	QPSK, BW 40MHz, RB Size 1, RB Offset 1
8	5	n77	M	QPSK, BW 100MHz, RB Size 1, RB Offset 1

5G NSA (ENDC Combos)

Cases	Ant.	Band	Channel		configuration	
			LTE	5GNR	LTE	5GNR
1	1+4	2A+n7A	M	M	QPSK, BW 20MHz, RB Size 1, RB Offset 0	QPSK, BW 50MHz, RB Size 1, RB Offset 1
2	1+4	7A+n66A	M	M	QPSK, BW 20MHz, RB	QPSK, BW 40MHz, RB

					Size 1, RB Offset 0	Size 1, RB Offset 1
3	1+4	66A+n41A	M	M	QPSK, BW 20MHz, RB Size 1, RB Offset 0	QPSK, BW 100MHz, RB Size 1, RB Offset 1
4	1+5	41A+n78A	M	M	QPSK, BW 20MHz, RB Size 1, RB Offset 0	QPSK, BW 100MHz, RB Size 1, RB Offset 1
5	1+4	66A+n38A	M	M	QPSK, BW 20MHz, RB Size 1, RB Offset 0	QPSK, BW 40MHz, RB Size 1, RB Offset 1

other PA

Cases	Ant.	Band	Channel		configuration	
			LTE	5GNR	LTE	5GNR
1	1+4	4A+n2A	M	M	QPSK, BW 20MHz, RB Size 1, RB Offset 0	QPSK, BW 40MHz, RB Size 1, RB Offset 1
2	4+1	5A+n66A	M	M	QPSK, BW 10MHz, RB Size 1, RB Offset 0	QPSK, BW 40MHz, RB Size 1, RB Offset 1

Remark:

6. If there is over one kind of accessories, each one should be applied in all the test modes.

7. All the cases will be tested the Traffic Mode.

Traffic Mode: When the EUT state is switched on and with Radio Resource Control (RRC) connection established.

8. Pre-scanned harmonic for the different antenna combinations, we choose the worst antenna mode to perform final test. Only the worst case will be recorded in this report.

4.2 Configuration Of Test System

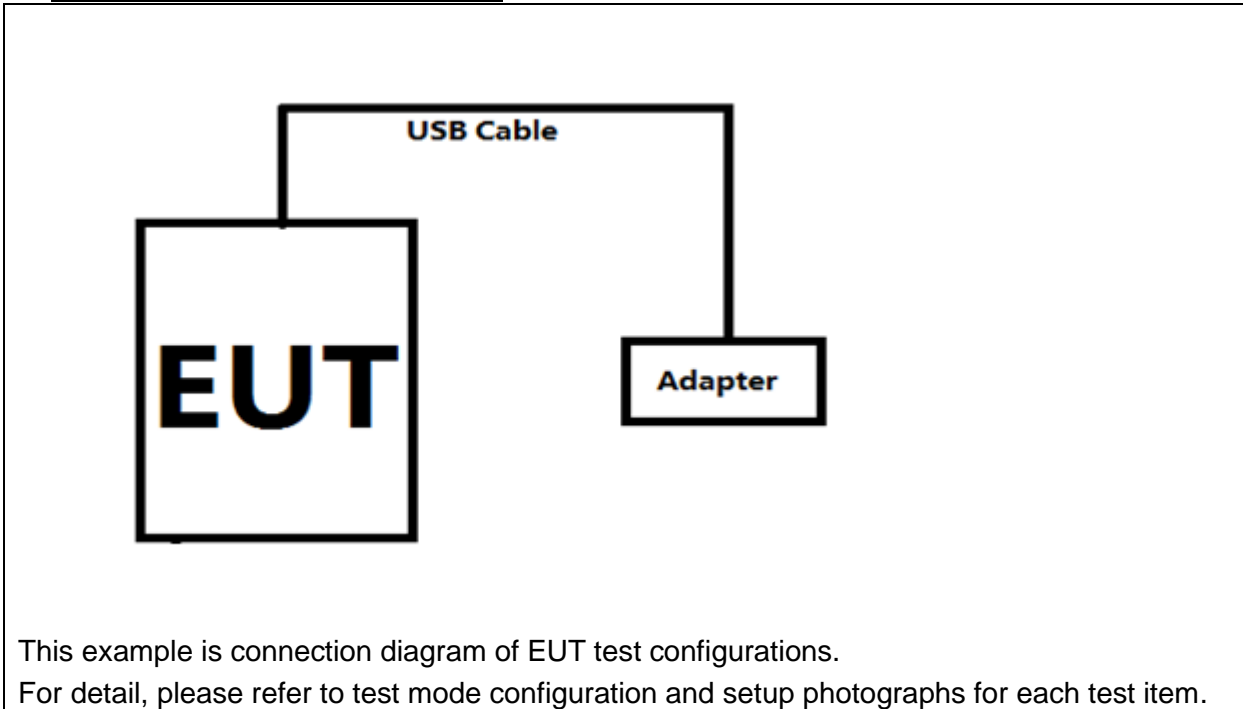

This example is connection diagram of EUT test configurations.
 For detail, please refer to test mode configuration and setup photographs for each test item.

4.3 Support Unit For Test

Name	Model Name	Manufacturer	S/N
System Simulator	CMX500	R&S	102510

5. Test Description

5.1 Radiated spurious emissions

5.1.1 Limit

Based on 47 CFR Part 22,24,27,90, the RF fundamental frequency should be excluded against the limit line in the operating frequency band.

The limit line example:

$$43 + 10\log(P)\text{dB below the transmitter power } P(\text{Watts})$$

$$= P(\text{W}) - [43 + 10\log(P)] (\text{dB})$$

$$= [30 + 10\log(P)] (\text{dBm}) - [43 + 10\log(P)] (\text{dB})$$

$$= -13\text{dBm.}$$

5.1.2 Test Procedure

1. The testing follows ANSI C63.26 Section 5.5.
 2. The EUT was placed on a turntable with 0.8 meter height for frequency below 1GHz and 1.5 meter height for frequency above 1GHz respectively above ground.
 3. The EUT was set 3 meters from the receiving antenna mounted on the antenna tower.
 4. The table was rotated 360 degrees to determine the position of the highest spurious emission.
 5. The height of the receiving antenna is varied between 1m to 4m to search the maximum spurious emission for both horizontal and vertical polarizations.
 6. During the measurement, the system simulator parameters were set to force the EUT transmitting at maximum output power.
 7. Make the measurement with the spectrum analyzer's RBW=100kHz(30M~1GHz) or 1MHz(above 1GHz), VBW=300kHz(30M~1GHz) or 1MHz(above 1GHz), taking the record of maximum spurious emission.
 8. Radiated measurement using the Field Strength Method. Using the test configuration shown in 5.1.3. We measure the radiated emissions directly from the EUT and convert the measured field strength or received power to ERP or EIRP, as required, for comparison to the applicable limits. As stated in 5.5.1 of ANSI C63.26-2015, the field strength measurement method using a test site validated to the requirements of ANSI C63.4 is an alternative to the substitution measurement method.
 9. Radiated Power Measurement Calculation According to ANSI C63.26-2015.
 - a) $E (\text{dB}\mu\text{V}/\text{m}) = \text{Measured amplitude level (dB}\mu\text{V}) + \text{Cable Loss (dB)} + \text{Antenna Factor (dB/m)}$.
 - b) $E (\text{dB}\mu\text{V}/\text{m}) = \text{Measured amplitude level (dBm)} + 107 + \text{Cable Loss (dB)} + \text{Antenna Factor (dB/m)}$.
 - c) $E (\text{dB}\mu\text{V}/\text{m}) = \text{EIRP (dBm)} - 20\log(D) + 104.8$; where D is the measurement distance (in the far field region) in m.
 - d) $\text{EIRP (dBm)} = E (\text{dB}\mu\text{V}/\text{m}) + 20\log(D) - 104.8$; where D is the measurement distance (in the far field region) in m.
- So, from d)
- The measuring distance is usually at 3m, then $20*\text{Log}(3)=9.5424$.
- Then, $\text{EIRP (dBm)} = E (\text{dB}\mu\text{V}/\text{m}) + 9.5424 - 104.8 = E (\text{dB}\mu\text{V}/\text{m}) - 95.2576$.
10. If the emission level of the EUT in PEAK measurement mode was 3 dB lower than the limit specified, peak values of EUT will be reported. Otherwise, the level will be measured by using the RMS mode and reported.

Test Set-up

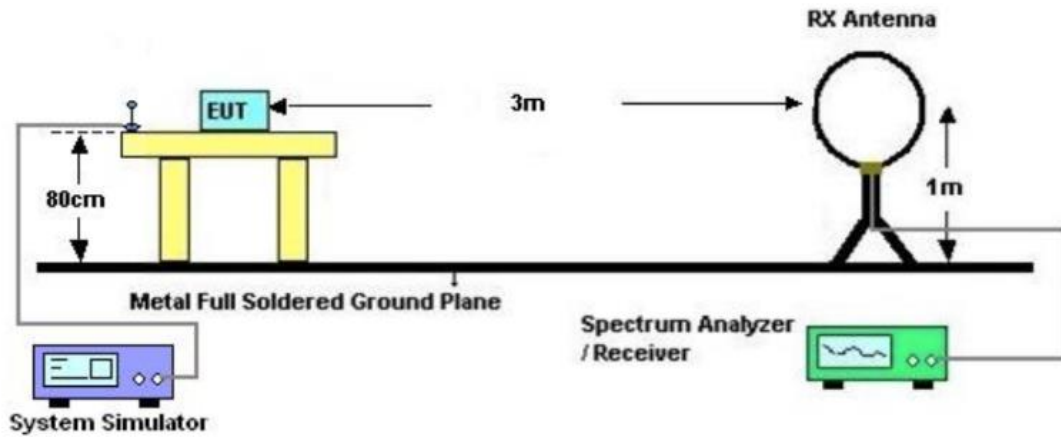

Figure.1 Test set-up of radiated emissions (Below 30MHz)

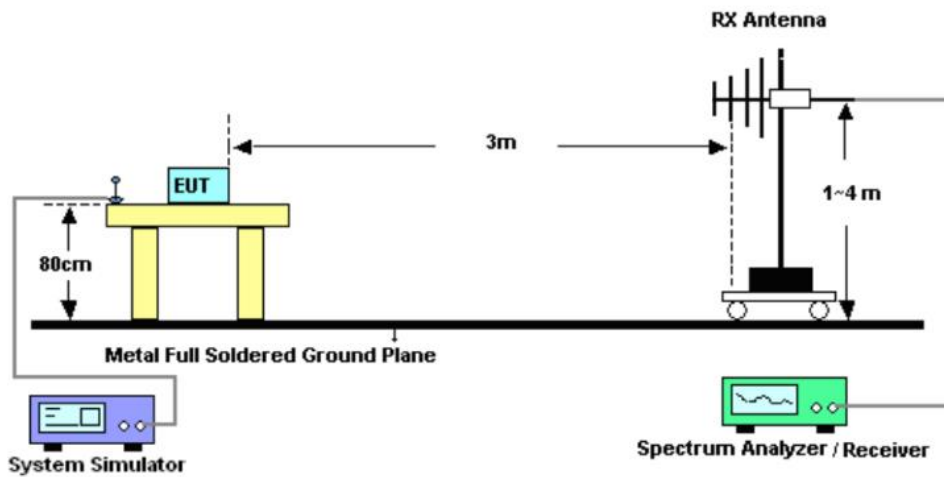

Figure.2 Test set-up of radiated emissions (30MHz~1GHz)

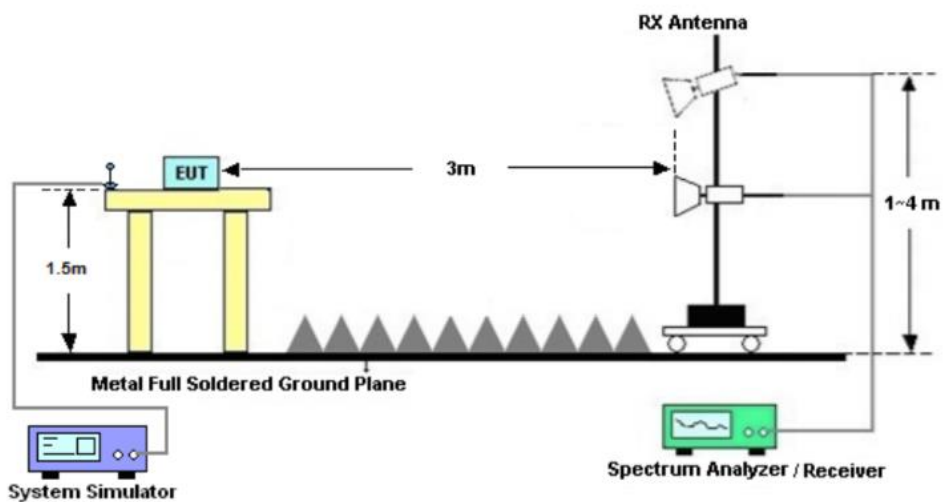

Figure.3 Test set-up of radiated emissions (above 1GHz)

5.1.3 Test Results

The EUT has met the requirements.

Test data refer to the section 7.1 of this report.

Only the worst test result was shown in this report.

Only the plots of the worst case are shown in this report.

The low frequency, which started from 9 kHz to 30MHz, was pre-scanned and the result which was 20dB lower than the limit line was not reported.

The data example:

Channel	Frequency (MHz)	EIRP (dBm)	Limit (dBm)	Over Limit (dB)	Correction [dB]	Detector	Polarization (H/V)
M	7639	-33.49	-25.00	-8.49	39.27	PK	H

Correction = Antenna factor + Cable loss – Preamplifier gain

E (dBuV/m) = Reading level + Correction

The measuring distance is 3m, then

EIRP= E (dBuV/m) - 95.26= Reading level + Correction- 95.26= Reading level+ Antenna factor + Cable loss – Preamplifier gain- 95.26

Over Limit = EIRP – Limit

Note: Reading level/ Antenna factor /Cable loss /Preamplifier gain are calculated by software background and are not shown in the data sheet.

6. Test Equipment And Software

Main Test Equipment						
Test items	Instrument	Manufacturer	Model No.	Serial No.	Calibration Date	Calibration interval(year)
RSE	Log-per.-Antenna	R&S	VULB9163	9163-893	2024/01/19	2
	Double Ridged Horde Antenna	R&S	HF907	100545	2025/02/10	3
	Double Ridged Horde Antenna	R&S	QWH-SL-18-40-K-SG	12004	2025/02/10	3
	Loop Antenna	R&S	FMZB	1513	2024/04/23	3
	EMI Test Receiver (Below30MHz /30M~1GHz)	R&S	ESR7	101188	2024/07/08	1
	Signal Analyzer (Above 1GHz)	R&S	FSV40	100956	2024/11/13	1
	SAC	ETS	/	5582	2025/01/15	3
	Turn Table	ETS	TT	2090	/	/
	Maturo NCA	Maturo	NCDv2.0	/	/	/
	Antenna Mast	Maturo	BAM 4.0-P	92536	/	/
	SCU18F	R&S	/	101084	/	/
	SCU40H48M	R&S	/	100250	/	/
	OSP	R&S	B155G	100852	/	/
Remark: OSP(B155G) is an integrated system of amplifiers and attenuators, for the frequency range of 1G -18 GHz, and during measurement the internal path will be switched to the appropriate amplifier and attenuator corresponding to frequencies to be measured. The complete system frequency response is verified prior to the measurement.						
Software Information						
Test Item	Software Name			Version		
RSE	ELEKTRA			V5.05.0		

7. System Measurement Uncertainty

The measurement uncertainties shown below were calculated in accordance with the requirements of ANSI 63.26-2015. All the measurement uncertainty value were shown with a coverage K=2 to indicate 95% level of confidence. The measurement data show herein meets or exceeds the CISPR measurement uncertainty values specified in CISPR 16-4-2 and can be compared directly to specified limit to determine compliance.

Measurement Uncertainty	
Items	Extended Uncertainty
RE(30MHz~1GHz)	U=5.9dB; k=2
RE(1GHz~18GHz)	U=5.0dB; k=2
RE(18GHz-40GHz)	U=5.1dB; k=2

Test Data

7.1 RSE

Worse plot(N41 SA)

1G-18G H

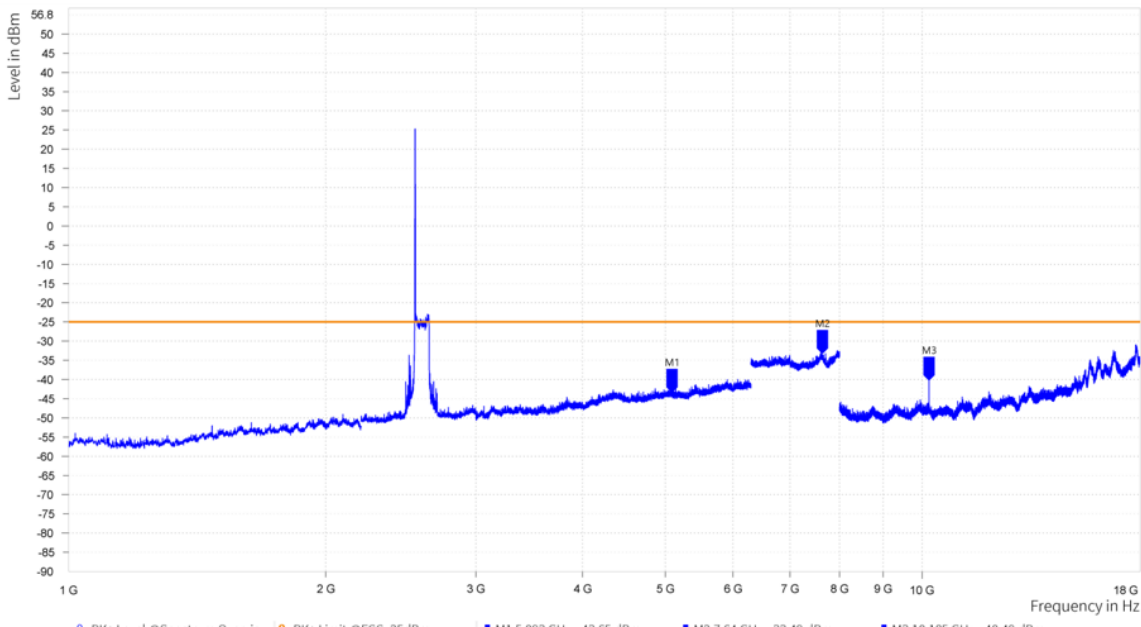

1G-18G V

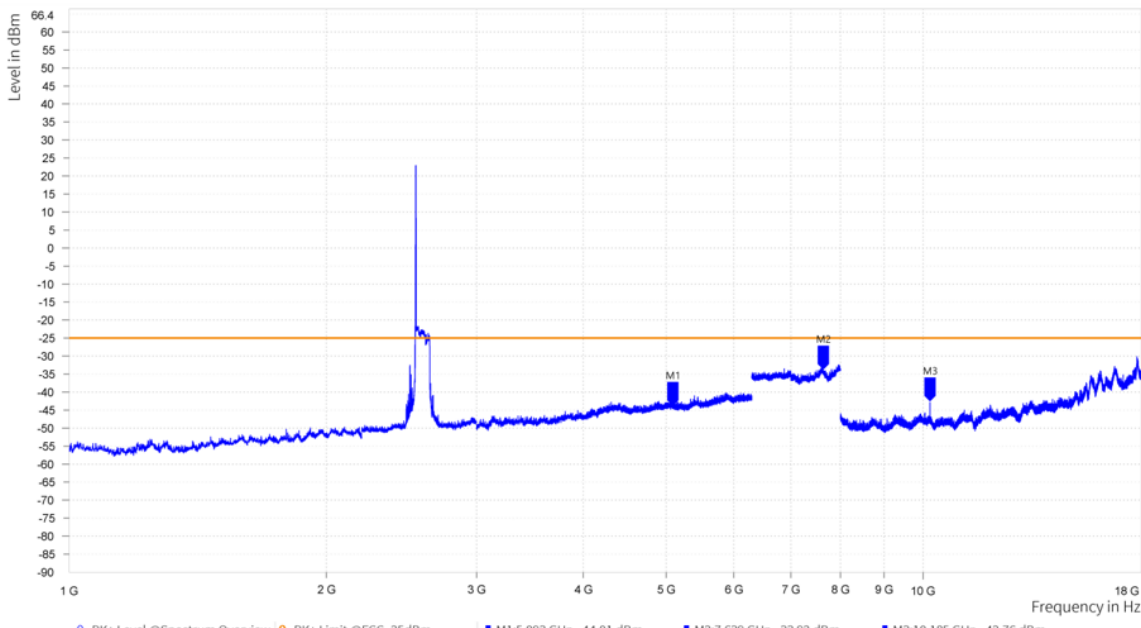

18G-40G-H

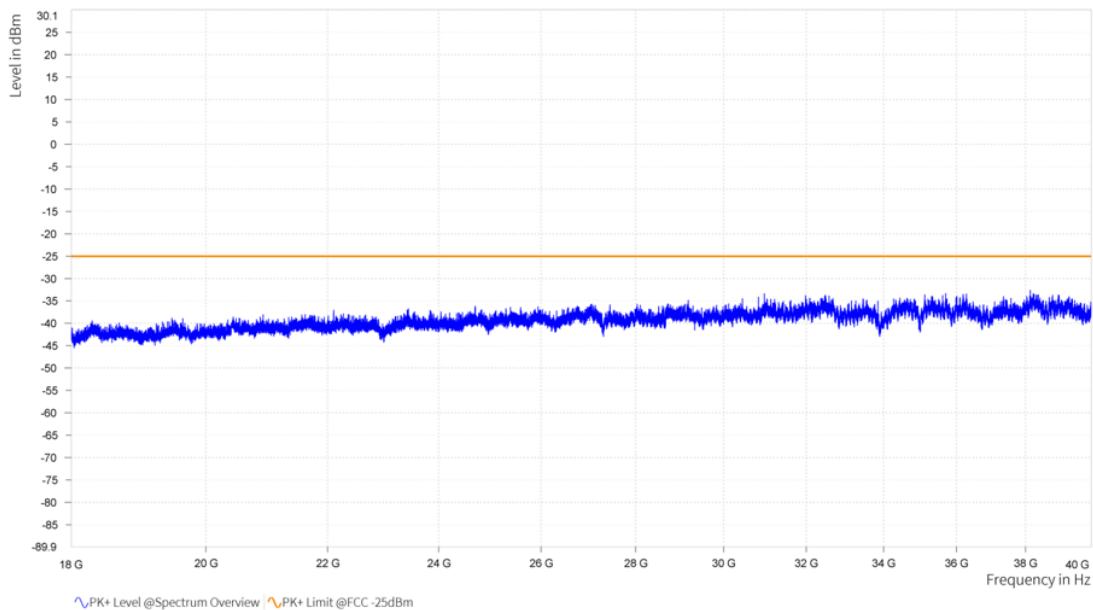

18G-40G-V

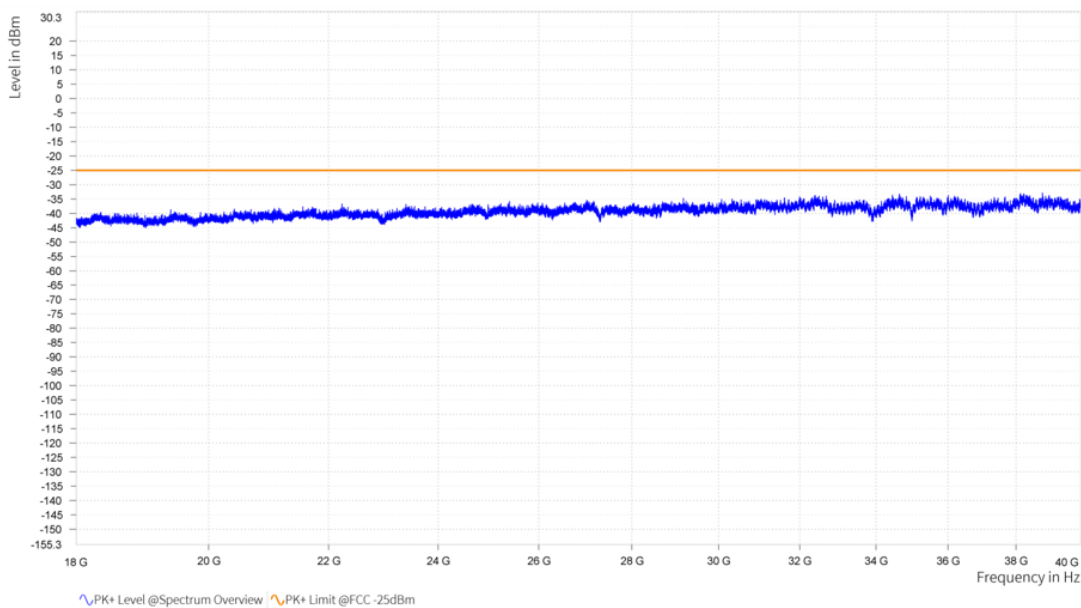

Data Table

N2 SA							
Channel	Frequency (MHz)	EIRP (dBm)	Limit (dBm)	Over Limit (dB)	Correction [dB]	Detector	Polarization (H/V)
Middle	3740	-47.78	-13.00	-34.78	25.39	PK	H
	5612	-37.67	-13.00	-24.67	29.84	PK	H
	7360	-36.71	-13.00	-23.71	37.92	PK	H
	3740	-47.64	-13.00	-34.64	25.39	PK	V
	5612	-37.75	-13.00	-24.75	29.84	PK	V
	7360	-34.33	-13.00	-21.33	38.53	PK	V

Remark: Spurious emissions within 30-1000MHz were found more than 20dB below limit line.

DC_4A_n2A/other PA							
Channel	Frequency (MHz)	EIRP (dBm)	Limit (dBm)	Over Limit (dB)	Correction [dB]	Detector	Polarization (H/V)
Middle	3722	-47.91	-13.00	-34.91	25.21	PK	H
	5583	-43.09	-13.00	-30.09	29.70	PK	H
	7440	-35.99	-13.00	-22.99	38.17	PK	H
	3722	-47.83	-13.00	-34.83	25.21	PK	V
	5583	-43.16	-13.00	-30.16	29.70	PK	V
	7440	-35.98	-13.00	-22.98	38.19	PK	V

Remark: Spurious emissions within 30-1000MHz were found more than 20dB below limit line.

N7 SA							
Channel	Frequency (MHz)	EIRP (dBm)	Limit (dBm)	Over Limit (dB)	Correction [dB]	Detector	Polarization (H/V)
Middle	5022	-44.37	-25.00	-19.37	29.35	PK	H
	7533	-34.21	-25.00	-9.21	38.68	PK	H
	10044	-41.80	-25.00	-16.80	26.52	PK	H
	5022	-44.46	-25.00	-19.46	29.35	PK	V
	7533	-35.13	-25.00	-10.13	38.68	PK	V
	10044	-45.13	-25.00	-20.13	26.52	PK	V

Remark: Spurious emissions within 30-1000MHz were found more than 20dB below limit line.

N26 SA/Part 22							
Channel	Frequency (MHz)	EIRP (dBm)	Limit (dBm)	Over Limit (dB)	Correction [dB]	Detector	Polarization (H/V)
Middle	1654	-27.54	-13.00	-14.54	16.65	RMS	H
	2481	-57.10	-13.00	-44.10	20.26	RMS	H
	3308	-58.59	-13.00	-45.59	24.18	RMS	H
	1654	-22.64	-13.00	-9.64	16.65	RMS	V
	2481	-55.91	-13.00	-42.91	20.26	RMS	V
	3308	-58.70	-13.00	-45.70	24.18	RMS	V

Remark: Spurious emissions within 30-1000MHz were found more than 20dB below limit line.

N26 SA/Part 90							
Channel	Frequency (MHz)	EIRP (dBm)	Limit (dBm)	Over Limit (dB)	Correction [dB]	Detector	Polarization (H/V)
Middle	1629	-24.63	-13.00	-11.63	16.74	RMS	H
	2444	-46.26	-13.00	-33.26	19.90	RMS	H
	3258	-57.94	-13.00	-44.94	24.08	RMS	H
	1629	-23.86	-13.00	-10.86	16.74	RMS	V
	2444	-44.36	-13.00	-31.36	19.90	RMS	V
	3258	-58.43	-13.00	-45.43	24.08	RMS	V

Remark: Spurious emissions within 30-1000MHz were found more than 20dB below limit line.

N38 SA							
Channel	Frequency (MHz)	EIRP (dBm)	Limit (dBm)	Over Limit (dB)	Correction [dB]	Detector	Polarization (H/V)
Middle	5153	-43.74	-25.00	-18.74	28.89	PK	H
	7729	-35.24	-25.00	-10.24	39.24	PK	H
	10306	-44.41	-25.00	-19.41	25.82	PK	H
	5153	-42.67	-25.00	-17.67	28.89	PK	V
	7729	-36.27	-25.00	-11.27	39.24	PK	V
	10306	-47.40	-25.00	-22.40	25.82	PK	V

Remark: Spurious emissions within 30-1000MHz were found more than 20dB below limit line.

N41 SA							
Channel	Frequency (MHz)	EIRP (dBm)	Limit (dBm)	Over Limit (dB)	Correction [dB]	Detector	Polarization (H/V)
Middle	5093	-43.65	-25.00	-18.65	29.03	PK	H
	7639	-33.49	-25.00	-8.49	39.27	PK	H
	10185	-40.05	-25.00	-15.05	26.53	PK	H
	5093	-44.03	-25.00	-19.03	29.03	PK	V
	7639	-33.92	-25.00	-8.92	39.27	PK	V
	10185	-42.75	-25.00	-17.75	26.53	PK	V

Remark: Spurious emissions within 30-1000MHz were found more than 20dB below limit line.

N66 SA							
Channel	Frequency (MHz)	EIRP (dBm)	Limit (dBm)	Over Limit (dB)	Correction [dB]	Detector	Polarization (H/V)
Middle	3471	-47.55	-13.00	-34.55	24.23	PK	H
	5207	-37.64	-13.00	-24.64	28.92	PK	H
	6942	-35.10	-13.00	-22.10	37.06	PK	H
	3471	-47.63	-13.00	-34.63	24.23	PK	V
	5207	-38.71	-13.00	-25.71	28.92	PK	V
	6942	-35.77	-13.00	-22.77	37.06	PK	V

Remark: Spurious emissions within 30-1000MHz were found more than 20dB below limit line.

DC_5A_n66A/other PA							
Channel	Frequency (MHz)	EIRP (dBm)	Limit (dBm)	Over Limit (dB)	Correction [dB]	Detector	Polarization (H/V)
Middle	3472	-47.86	-13.00	-34.86	24.23	PK	H
	5208	-44.16	-13.00	-31.16	28.91	PK	H
	6944	-35.17	-13.00	-22.17	37.07	PK	H
	3472	-48.14	-13.00	-35.14	24.23	PK	V
	5208	-44.34	-13.00	-31.34	28.91	PK	V
	6944	-35.61	-13.00	-22.61	37.07	PK	V

Remark: Spurious emissions within 30-1000MHz were found more than 20dB below limit line.

N77 SA							
Channel	Frequency (MHz)	EIRP (dBm)	Limit (dBm)	Over Limit (dB)	Correction [dB]	Detector	Polarization (H/V)
Middle	6902	-35.13	-13.00	-22.13	37.06	PK	H
	10353	-48.70	-13.00	-35.70	25.95	PK	H
	13804	-44.66	-13.00	-31.66	30.88	PK	H
	6902	-35.08	-13.00	-22.08	37.06	PK	V
	10353	-49.76	-13.00	-36.76	25.95	PK	V
	13804	-44.08	-13.00	-31.08	30.88	PK	V

Remark: Spurious emissions within 30-1000MHz were found more than 20dB below limit line.

DC_2A_n7A							
Channel	Frequency (MHz)	EIRP (dBm)	Limit (dBm)	Over Limit (dB)	Correction [dB]	Detector	Polarization (H/V)
Middle	5022	-44.03	-25.00	-19.03	29.35	PK	H
	7533	-35.41	-25.00	-10.41	38.68	PK	H
	10044	-46.68	-25.00	-21.68	26.52	PK	H
	5022	-43.69	-25.00	-18.69	29.35	PK	V
	7533	-34.77	-25.00	-9.77	38.68	PK	V
	10044	-47.42	-25.00	-22.42	26.53	PK	V

Remark: Spurious emissions within 30-1000MHz were found more than 20dB below limit line.

DC_7A_n66A							
Channel	Frequency (MHz)	EIRP (dBm)	Limit (dBm)	Over Limit (dB)	Correction [dB]	Detector	Polarization (H/V)
Middle	3471	-48.60	-13.00	-35.60	24.23	PK	H
	5206	-43.58	-13.00	-30.58	28.93	PK	H
	6942	-35.18	-13.00	-22.18	37.06	PK	H
	3471	-48.60	-13.00	-35.60	24.23	PK	V
	5206	-44.18	-13.00	-31.18	28.91	PK	V
	6942	-35.62	-13.00	-22.62	37.07	PK	V

Remark: Spurious emissions within 30-1000MHz were found more than 20dB below limit line.

DC_66A_n41A							
Channel	Frequency (MHz)	EIRP (dBm)	Limit (dBm)	Over Limit (dB)	Correction [dB]	Detector	Polarization (H/V)
Middle	3471	-32.05	-25.00	-7.05	28.91	PK	H
	5206	-34.28	-25.00	-9.28	39.25	PK	H
	6942	-43.79	-25.00	-18.79	26.51	PK	H
	3471	-39.16	-25.00	-14.16	28.91	PK	V
	5206	-34.00	-25.00	-9.00	39.25	PK	V
	6942	-48.65	-25.00	-23.65	26.51	PK	V

Remark: Spurious emissions within 30-1000MHz were found more than 20dB below limit line.

DC_41A_n78A							
Channel	Frequency (MHz)	EIRP (dBm)	Limit (dBm)	Over Limit (dB)	Correction [dB]	Detector	Polarization (H/V)
Middle	6903	-34.39	-13.00	-21.39	37.06	PK	H
	10353	-48.68	-13.00	-35.68	25.97	PK	H
	13806	-43.63	-13.00	-30.63	30.88	PK	H
	6903	-36.08	-13.00	-23.08	37.06	PK	V
	10353	-47.78	-13.00	-34.78	25.96	PK	V
	13806	-41.78	-13.00	-28.78	30.88	PK	V

Remark: Spurious emissions within 30-1000MHz were found more than 20dB below limit line.

DC_66A_n38A							
Channel	Frequency (MHz)	EIRP (dBm)	Limit (dBm)	Over Limit (dB)	Correction [dB]	Detector	Polarization (H/V)
Middle	5153	-44.55	-25.00	-19.55	28.89	PK	H
	7729	-36.23	-25.00	-11.23	39.24	PK	H
	10306	-47.18	-25.00	-22.18	25.82	PK	H
	5153	-44.30	-25.00	-19.30	28.89	PK	V
	7729	-36.53	-25.00	-11.53	39.24	PK	V
	10306	-48.31	-25.00	-23.31	25.82	PK	V

Remark: Spurious emissions within 30-1000MHz were found more than 20dB below limit line.