



FCC RF Test Report

APPLICANT : Motorola Mobility LLC
EQUIPMENT : Mobile Cellular Phone
BRAND NAME : Motorola
MODEL NAME : XT2529-1
FCC ID : IHDT56AV1
STANDARD : 47 CFR Part 27(M)
CLASSIFICATION : PCS Licensed Transmitter Held to Ear (PCE)
TEST DATE(S) : Apr. 29, 2025

We, Sporton International Inc. (Shenzhen), would like to declare that the tested sample has been evaluated in accordance with the procedures given in ANSI C63.26-2015 and shown compliance with the applicable technical standards.

The test results in this report apply exclusively to the tested model / sample. Without written approval of Sporton International Inc. (Shenzhen), the test report shall not be reproduced except in full.

Fly Liang



Approved by: Fly Liang

Sporton International Inc. (ShenZhen)

1/F, 2/F, Bldg 5, Shiling Industrial Zone, Xinwei Village, Xili, Nanshan, Shenzhen, 518055

People's Republic of China



TABLE OF CONTENTS

REVISION HISTORY...3
SUMMARY OF TEST RESULT...4
1 GENERAL DESCRIPTION...5
1.1 Applicant...5
1.2 Manufacturer...5
1.3 Product Feature of Equipment Under Test...5
1.4 Product Specification of Equipment Under Test...5
1.5 Modification of EUT...6
1.6 Maximum EIRP and Emission Designator...6
1.7 Testing Location...6
1.8 Applicable Standards...7
2 TEST CONFIGURATION OF EQUIPMENT UNDER TEST...8
2.1 Test Mode...8
2.2 Support Unit used in test configuration and system...8
2.3 Measurement Results Explanation Example...9
2.4 Frequency List of Low/Middle/High Channels...9
3 CONDUCTED TEST ITEMS...10
3.1 Measuring Instruments...10
3.2 Test Setup...10
3.3 Test Result of Conducted Test...10
3.4 Conducted Output Power and EIRP...11
3.5 Peak-to-Average Ratio...12
3.6 Occupied Bandwidth...13
3.7 Conducted Band Edge...14
3.8 Conducted Spurious Emission...15
4 LIST OF MEASURING EQUIPMENT...16
5 MEASUREMENT UNCERTAINTY...17
APPENDIX A. TEST RESULTS OF CONDUCTED TEST



SUMMARY OF TEST RESULT

Report Section	FCC Rule	Description	Limit	Result	Remark
3.4	§2.1046	Conducted Output Power	Reporting Only	PASS	-
	§27.50(h)(2)	Equivalent Isotropic Radiated Power (5G NR n38)	EIRP < 2Watt		
3.5	§24.232(d) §27.50(j)(4)	Peak-to-Average Ratio	<13 dB	PASS	-
3.6	§2.1049	Occupied Bandwidth	Reporting Only	PASS	-
3.7	§27.53(m)(4)	Conducted Band Edge Measurement (5G NR n38)	§27.53(m)(4)	PASS	-
3.8	§2.1051 §27.53(m)(4)	Conducted Spurious Emission (5G NR n38)	< 55+10log ₁₀ (P[Watts])	PASS	-

Note:

This is a variant report for XT2529-1. The difference between current and previous is as below:

Add 5G NR n38 bandwidth 5M (SCS 15kHz only) by software.

Since the conducted power is less than the original report, only the n38 bandwidth 5M was tested for conducted, all the other test results refer to the original report FG520602G.

Conformity Assessment Condition:
1. The test results (PASS/FAIL) with all measurement uncertainty excluded are presented against the regulation limits or in accordance with the requirements stipulated by the applicant/manufacturer who shall bear all the risks of non-compliance that may potentially occur if measurement uncertainty is taken into account.
2. The measurement uncertainty please refer to each test result in the section "Measurement Uncertainty"
Disclaimer:
The product specifications of the EUT presented in the test report that may affect the test assessments are declared by the manufacturer who shall take full responsibility for the authenticity.



1 General Description

1.1 Applicant

Motorola Mobility LLC
222 W,Merchandise Mart Plaza, Chicago IL 60654 USA

1.2 Manufacturer

Motorola Mobility LLC
222 W,Merchandise Mart Plaza, Chicago IL 60654 USA

1.3 Product Feature of Equipment Under Test

Product Feature	
Equipment	Mobile Cellular Phone
Brand Name	Motorola
Model Name	XT2529-1
FCC ID	IHDT56AV1
IMEI Code	Conducted : 351291190034439/351291190034447
HW Version	DVT2
SW Version	V2VO35.57
EUT Stage	Identical Prototype

1.4 Product Specification of Equipment Under Test

Standards-related Product Specification	
Tx Frequency	5G NR n38: 2570 MHz ~ 2620 MHz
Rx Frequency	5G NR n38: 2570 MHz ~ 2620 MHz
Bandwidth	For SCS 15kHz: n38: 5MHz / 10MHz / 15MHz / 20MHz / 25MHz / 30MHz / 40MHz For SCS 30kHz: n38: 10MHz / 15MHz / 20MHz / 25MHz / 30MHz / 40MHz
SCS	15kHz, 30kHz
Antenna Gain	<Ant. 1>: n38: -3.9 dBi <Ant. 4>: n38: -4.1 dBi
Type of Modulation	CP-OFDM: QPSK / 16QAM / 64QAM / 256QAM DFT-s-OFDM: PI/2 BPSK / QPSK / 16QAM / 64QAM / 256QAM

Remark:

1. The maximum EIRP is calculated from max output power and max antenna gain, only the maximum EIRP are shown in the report, 5G NR n38 for Ant. 1.
2. All the supported ENDC combinations are verified conducted power, only the ENDC combination with highest power are shown in the report.
3. 5G NR n38 support SCS 15kHz and 30kHz. According to the maximum power, full test 15kHz to



cover 30kHz for n38;

- 4. 5G NR n38 support SA mode and NSA mode. According to the maximum power between SA and NSA mode, SA covers NSA mode.
- 5. The device supports two PAs for 5G NR n38 (main PA, and other PA support NSA mode only), both the PAs are full test, only the worst EIRP are shown in the report.
- 6. The EN-DC mode combination could be referred to the product spec.

1.5 Modification of EUT

No modifications are made to the EUT during all test items.

1.6 Maximum EIRP and Emission Designator

5G NR n38 for SCS 15kHz		PI/2 BPSK / QPSK		16QAM / 64QAM / 256QAM	
BW (MHz)	Frequency Range (MHz)	Maximum EIRP(W)	Emission Designator (99%OBW)	Maximum EIRP(W)	Emission Designator (99%OBW)
5	2572.5 ~ 2617.5	0.0897	4M48G7D	0.0713	4M47W7D

Note: All modulations have been tested, only the worst test results of PSK & QAM are shown in the report.

1.7 Testing Location

Sporton International Inc. (ShenZhen) is accredited to ISO/IEC 17025:2017 by American Association for Laboratory Accreditation with Certificate Number 5145.01.

Test Firm	Sporton International Inc. (ShenZhen)		
Test Site Location	101, 1st Floor, Block B, Building 1, No. 2, Tengfeng 4th Road, Fenghuang Community, Fuyong Street, Baoan District, Shenzhen City, Guangdong Province 518103 People's Republic of China TEL: +86-755-86066985		
Test Site No.	Sporton Site No.	FCC Designation No.	FCC Test Firm Registration No.
	TH01-SZ	CN1256	421272



1.8 Applicable Standards

According to the specifications of the manufacturer, the EUT must comply with the requirements of the following standards:

- ♦ 47 CFR Part 27
- ♦ ANSI C63.26-2015
- ♦ FCC KDB 971168 D01 Power Meas License Digital Systems v03r01
- ♦ FCC KDB 412172 D01 Determining ERP and EIRP v01r01

Remark:

All test items were verified and recorded according to the standards and without any deviation during the test.



2 Test Configuration of Equipment Under Test

2.1 Test Mode

Antenna port conducted and radiated test items are performed according to KDB 971168 D01 Power Meas License Digital Systems v03r01 with maximum output power.

Test Items	5G NR	Bandwidth (MHz)												Modulation					RB #		Test Channel					
		5	10	15	20	25	30	35	40	50	60	70~80	90	100	PI/2 BPSK	QPSK	16 QAM	64 QAM	256 QAM	1	Full	L	M	H		
Max. Output Power	n38	v						-		-	-	-	-	-	v	v	v	v	v	v	v			v	v	v
Peak-to-Average Ratio	n38	v						-		-	-	-	-	-	v	v										v
26dB and 99% Bandwidth	n38	v						-		-	-	-	-	-		v	v	v	v							v
Conducted Band Edge	n38	v						-		-	-	-	-	-	v	v										v
Conducted Spurious Emission	n38	v						-		-	-	-	-	-	v	v										v
E.I.R.P	n38	v						-		-	-	-	-	-	v	v	v	v	v	v	v	v	v	v	v	v
Note	1. The mark "v " means that this configuration is chosen for testing 2. The mark "-" means that this bandwidth is not supported. 3. The device is investigated from 30MHz to 10 times of fundamental signal for radiated spurious emission test under different RB size/offset and modulations in exploratory test. Subsequently, only the worst case emissions are reported. 4. Frequency Stability: Normal Voltage = 3.91V; Low Voltage =3.45V; High Voltage =4.5V;																									

2.2 Support Unit used in test configuration and system

Item	Equipment	Trade Name	Model No.	FCC ID	Data Cable	Power Cord
1.	DC Power Supply	GW	GPS-3030D	N/A	N/A	Unshielded, 1.8 m
2.	LTE Base Station	Anritsu	MT8821C	N/A	N/A	Unshielded, 1.8 m
3.	NR Base Station	Anritsu	MT8000A	N/A	N/A	Unshielded, 1.8 m
4.	Earphone	N/A	N/A	N/A	N/A	N/A



2.3 Measurement Results Explanation Example

For all conducted test items:

The offset level is set in the spectrum analyzer to compensate the RF cable loss between EUT conducted output port and spectrum analyzer. With the offset compensation, the spectrum analyzer reading level is exactly the EUT RF output level.

The spectrum analyzer offset is derived from RF cable loss and attenuator factor.

$$\text{Offset} = \text{RF cable loss.}$$

Following shows an offset computation example with cable loss 8.6 dB.

Example :

$$\begin{aligned} \text{Offset(dB)} &= \text{RF cable loss(dB)}. \\ &= 8.6 \text{ (dB)} \end{aligned}$$

2.4 Frequency List of Low/Middle/High Channels

5G NR n38 Channel and Frequency List				
BW [MHz]	Channel/Frequency(MHz)	Lowest	Middle	Highest
40	Channel	518000	519000	520000
	Frequency	2590	2595	2600
30	Channel	517000	519000	521000
	Frequency	2585	2595	2605
25	Channel	516500	519000	521500
	Frequency	2582.5	2595	2607.5
20	Channel	516000	519000	522000
	Frequency	2580	2595	2610
15	Channel	515500	519000	522500
	Frequency	2577.5	2595	2612.5
10	Channel	515000	519000	523000
	Frequency	2575	2595	2615
5	Channel	514500	519000	523500
	Frequency	2572.5	2595	2617.5

3 Conducted Test Items

3.1 Measuring Instruments

See list of measuring instruments of this test report.

3.2 Test Setup

3.2.1 Conducted Output Power

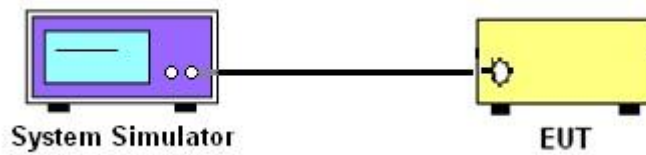

3.2.2 Peak-to-Average Ratio, Occupied Bandwidth ,Conducted Band-Edge and Conducted Spurious Emission

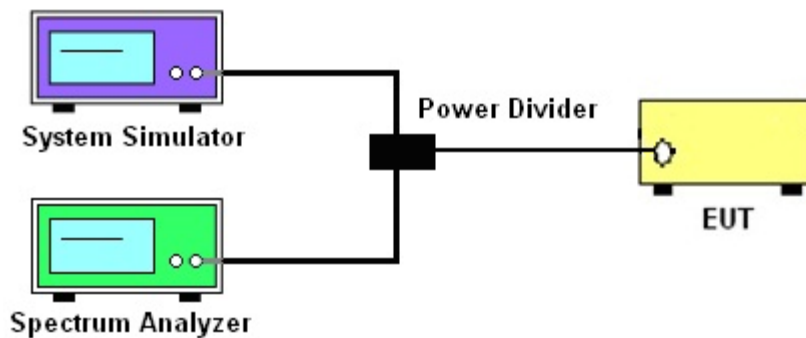

3.3 Test Result of Conducted Test

Please refer to Appendix A.



3.4 Conducted Output Power and EIRP

3.4.1 Description of the Conducted Output Power Measurement and EIRP Measurement

A system simulator was used to establish communication with the EUT. Its parameters were set to force the EUT transmitting at maximum output power. The measured power in the radio frequency on the transmitter output terminals shall be reported.

The EIRP of mobile transmitters must not exceed 2 Watts for 5G NR n38.

According to KDB 412172 D01 Power Approach,

$EIRP = P_T + G_T - L_C$, $ERP = EIRP - 2.15$, where

P_T = transmitter output power in dBm

G_T = gain of the transmitting antenna in dBi

L_C = signal attenuation in the connecting cable between the transmitter and antenna in dB

3.4.2 Test Procedures

1. The testing follows ANSI C63.26 Section 5.2
2. The transmitter output port was connected to the system simulator.
3. Set EUT at maximum power through the system simulator.
4. Select lowest, middle, and highest channels for each band and different modulation.
5. Measure and record the power level from the system simulator.



3.5 Peak-to-Average Ratio

3.5.1 Description of the PAR Measurement

Power Complementary Cumulative Distribution Function (CCDF) curves provide a means for characterizing the power peaks of a digitally modulated signal on a statistical basis. A CCDF curve depicts the probability of the peak signal amplitude exceeding the average power level. Most contemporary measurement instrumentation include the capability to produce CCDF curves for an input signal provided that the instrument's resolution bandwidth can be set wide enough to accommodate the entire input signal bandwidth. In measuring transmissions in this band using an average power technique, the peak-to-average ratio (PAR) of the transmission may not exceed 13 dB.

3.5.2 Test Procedures

1. The testing follows ANSI C63.26 Section 5.2.3.4 (CCDF).
2. The EUT was connected to spectrum and system simulator via a power divider.
3. Set the CCDF (Complementary Cumulative Distribution Function) option in spectrum analyzer.
4. The highest RF powers were measured and recorded the maximum PAPR level associated with a probability of 0.1 %.
5. Record the deviation as Peak to Average Ratio.



3.6 Occupied Bandwidth

3.6.1 Description of Occupied Bandwidth Measurement

The occupied bandwidth is the width of a frequency band such that, below the lower and above the upper frequency limits, the mean powers emitted are each equal to a specified percentage 0.5% of the total mean transmitted power.

The 26 dB emission bandwidth is defined as the frequency range between two points, one above and one below the carrier frequency, at which the spectral density of the emission is attenuated 26 dB below the maximum in-band spectral density of the modulated signal. Spectral density (power per unit bandwidth) is to be measured with a detector of resolution bandwidth equal to approximately 1.0% of the emission bandwidth.

3.6.2 Test Procedures

1. The testing follows ANSI C63.26 Section 5.4
2. The EUT was connected to spectrum analyzer and system simulator via a power divider.
3. The spectrum analyzer center frequency is set to the nominal EUT channel center frequency. The span range for the spectrum analyzer shall be between two and five times the anticipated OBW.
4. The nominal resolution bandwidth (RBW) shall be in the range of 1 to 5 % of the anticipated OBW, and the VBW shall be at least 3 times the RBW.
5. Set the detection mode to peak, and the trace mode to max hold.
6. Determine the reference value: Set the EUT to transmit a modulated signal. Allow the trace to stabilize. Set the spectrum analyzer marker to the highest level of the displayed trace.
(this is the reference value)
7. Determine the “-26 dB down amplitude” as equal to (Reference Value – X).
8. Place two markers, one at the lowest and the other at the highest frequency of the envelope of the spectral display such that each marker is at or slightly below the “-X dB down amplitude” determined in step 6. If a marker is below this “-X dB down amplitude” value it shall be placed as close as possible to this value. The OBW is the positive frequency difference between the two markers.
9. Use the 99 % power bandwidth function of the spectrum analyzer and report the measured bandwidth.



3.7 Conducted Band Edge

3.7.1 Description of Conducted Band Edge Measurement

27.53(m)(4)

For mobile digital stations, the attenuation factor shall be not less than $40 + 10 \log (P)$ dB on all frequencies between the channel edge and 5 megahertz from the channel edge, $43 + 10 \log (P)$ dB on all frequencies between 5 megahertz and X megahertz from the channel edge, and $55 + 10 \log (P)$ dB on all frequencies more than X megahertz from the channel edge, where X is the greater of 6 megahertz or the actual emission bandwidth as defined in paragraph (m)(6) of this section. In addition, the attenuation factor shall not be less that $43 + 10 \log (P)$ dB on all frequencies between 2490.5 MHz and 2496 MHz and $55 + 10 \log (P)$ dB at or below 2490.5 MHz. Mobile Satellite Service licensees operating on frequencies below 2495 MHz may also submit a documented interference complaint against BRS licensees operating on channel BRS Channel 1 on the same terms and conditions as adjacent channel BRS or EBS licensees.

3.7.2 Test Procedures

1. The testing follows ANSI C63.26 section 5.7
2. The EUT was connected to spectrum analyzer and system simulator via a power divider.
3. The band edges of low and high channels for the highest RF powers were measured.
4. Set RBW \geq 1% EBW in the 1MHz band immediately outside and adjacent to the band edge.
5. Beyond the 1 MHz band from the band edge, RBW=1MHz was used or a narrower RBW was used (generally limited to no less than 1% of the OBW) and the measured power was integrated over the full required measurement bandwidth.
6. Set spectrum analyzer with RMS detector.
7. The RF fundamental frequency should be excluded against the limit line in the operating frequency band.
8. Checked that all the results comply with the emission limit line.

Example:

The limit line is derived from $43 + 10\log(P)$ dB below the transmitter power P(Watts)
 $= P(W) - [43 + 10\log(P)]$ (dB)
 $= [30 + 10\log(P)]$ (dBm) - $[43 + 10\log(P)]$ (dB) = -13dBm.

9. For 5G NR n38, the other 40 dB, and 55 dB have additionally applied same calculation above.
10. When using the integration method, the starting frequency of the integration shall be centered at one-half of the RBW away from the band edge.



3.8 Conducted Spurious Emission

3.8.1 Description of Conducted Spurious Emission Measurement

For 5G NR n38:

The power of any emission outside of the authorized operating frequency ranges must be lower than the transmitter power (P) by a factor of at least $55 + 10 \log (P)$ dB.

It is measured by means of a calibrated spectrum analyzer and scanned from 30 MHz up to a frequency including its 10th harmonic.

3.8.2 Test Procedures

1. The testing follows ANSI C63.26 section 5.7
2. The EUT was connected to spectrum analyzer and system simulator via a power divider.
3. The RF output of EUT was connected to the spectrum analyzer by RF cable and attenuator. The path loss was compensated to the results for each measurement.
4. The middle channel for the highest RF power within the transmitting frequency was measured.
5. The conducted spurious emission for the whole frequency range was taken.
6. Make the measurement with the spectrum analyzer's RBW = 1MHz, VBW = 3MHz.
7. Set spectrum analyzer with RMS detector.
8. Taking the record of maximum spurious emission.
9. The RF fundamental frequency should be excluded against the limit line in the operating frequency band.

10. For 5G NR n38

The limit line is derived from $55 + 10\log(P)$ dB below the transmitter power P(Watts)
= P(W)- [55+ 10log(P)] (dB)
= [30+ 10log(P)] (dBm) - [55+ 10log(P)] (dB)
= -25dBm.



4 List of Measuring Equipment

Instrument	Manufacturer	Model No.	Serial No.	Characteristics	Calibration Date	Test Date	Due Date	Remark
Spectrum Analyzer	R&S	FSV40	101040	10Hz~40GHz	Oct. 10, 2024	Apr. 29, 2025	Oct. 09, 2025	Conducted (TH01-KS)
Pulse Power Sensor	Anritsu	MA2411B	0917070	300MHz~40GHz	Jan. 02, 2025	Apr. 29, 2025	Jan. 01, 2026	Conducted (TH01-KS)
Power Meter	Anritsu	ML2495A	1005002	50MHz Bandwidth	Jan. 02, 2025	Apr. 29, 2025	Jan. 01, 2026	Conducted (TH01-KS)

NCR: No Calibration Required



5 Measurement Uncertainty

The measurement uncertainties shown below were calculated in accordance with the requirements of ANSI 63.26-2015. All the measurement uncertainty value were shown with a coverage K=2 to indicate 95% level of confidence. The measurement data show herein meets or exceeds the CISPR measurement uncertainty values specified in CISPR 16-4-2 and can be compared directly to specified limit to determine compliance.

Uncertainty of Conducted Measurement

Conducted Spurious Emission & Bandedge	± 2.26 dB
Occupied Channel Bandwidth	$\pm 0.1\%$
Conducted Power	± 0.46 dB
Peak to Average Ratio	± 0.46 dB
Frequency Stability	± 0.4 Hz

----- THE END -----



Appendix A. Test Results of Conducted Test

Test Engineer :	Simle Wang	Temperature :	22~23°C
		Relative Humidity :	40~42%



Software Version: 23.06.1602

FR1 N38 (SCS15kHz)

Transmitter Conducted Output Power And EIRP, (G_T - L_c)= -3.9dBi

NR Band	SCS	Band Width	Arfcn	Freq (MHz)	Modulation	RB	Conducted Power(dBm)	EIRP (dBm)	EIRP (W)
38	15	5	514500	2572.5	DFT-s-OFDM PI/2 BPSK	12@6	23.32	19.42	0.0875
38	15	5	514500	2572.5	DFT-s-OFDM PI/2 BPSK	1@1	23.3	19.4	0.0871
38	15	5	514500	2572.5	DFT-s-OFDM PI/2 BPSK	1@23	23.32	19.42	0.0875
38	15	5	514500	2572.5	DFT-s-OFDM QPSK	12@6	23.32	19.42	0.0875
38	15	5	514500	2572.5	DFT-s-OFDM QPSK	1@1	23.43	19.53	0.0897
38	15	5	514500	2572.5	DFT-s-OFDM QPSK	1@23	23.33	19.43	0.0877
38	15	5	514500	2572.5	DFT-s-OFDM 16 QAM	12@6	22.35	18.45	0.0700
38	15	5	514500	2572.5	DFT-s-OFDM 16 QAM	1@1	22.15	18.25	0.0668
38	15	5	514500	2572.5	DFT-s-OFDM 16 QAM	1@23	22.18	18.28	0.0673
38	15	5	514500	2572.5	DFT-s-OFDM 64 QAM	12@6	20.83	16.93	0.0493
38	15	5	514500	2572.5	DFT-s-OFDM 64 QAM	1@1	20.83	16.93	0.0493
38	15	5	514500	2572.5	DFT-s-OFDM 64 QAM	1@23	20.94	17.04	0.0506
38	15	5	514500	2572.5	DFT-s-OFDM 256 QAM	12@6	18.95	15.05	0.0320
38	15	5	514500	2572.5	DFT-s-OFDM 256 QAM	1@1	18.69	14.79	0.0301
38	15	5	514500	2572.5	DFT-s-OFDM 256 QAM	1@23	18.71	14.81	0.0303
38	15	5	514500	2572.5	CP-OFDM QPSK	13@6	21.87	17.97	0.0627
38	15	5	514500	2572.5	CP-OFDM QPSK	1@1	21.86	17.96	0.0625
38	15	5	514500	2572.5	CP-OFDM QPSK	1@23	21.79	17.89	0.0615
38	15	5	518500	2592.5	DFT-s-OFDM PI/2 BPSK	12@6	23.37	19.47	0.0885
38	15	5	518500	2592.5	DFT-s-OFDM PI/2 BPSK	1@1	23.31	19.41	0.0873
38	15	5	518500	2592.5	DFT-s-OFDM PI/2 BPSK	1@23	23.35	19.45	0.0881
38	15	5	518500	2592.5	DFT-s-OFDM QPSK	12@6	23.38	19.48	0.0887
38	15	5	518500	2592.5	DFT-s-OFDM QPSK	1@1	23.39	19.49	0.0889
38	15	5	518500	2592.5	DFT-s-OFDM QPSK	1@23	23.41	19.51	0.0893
38	15	5	518500	2592.5	DFT-s-OFDM 16 QAM	12@6	22.43	18.53	0.0713
38	15	5	518500	2592.5	DFT-s-OFDM 16 QAM	1@1	22.25	18.35	0.0684
38	15	5	518500	2592.5	DFT-s-OFDM 16 QAM	1@23	22.21	18.31	0.0678
38	15	5	518500	2592.5	DFT-s-OFDM 64 QAM	12@6	20.9	17	0.0501
38	15	5	518500	2592.5	DFT-s-OFDM 64 QAM	1@1	21	17.1	0.0513
38	15	5	518500	2592.5	DFT-s-OFDM 64 QAM	1@23	21.05	17.15	0.0519
38	15	5	518500	2592.5	DFT-s-OFDM 256 QAM	12@6	19.04	15.14	0.0327
38	15	5	518500	2592.5	DFT-s-OFDM 256 QAM	1@1	18.87	14.97	0.0314
38	15	5	518500	2592.5	DFT-s-OFDM 256 QAM	1@23	18.79	14.89	0.0308
38	15	5	518500	2592.5	CP-OFDM QPSK	13@6	21.93	18.03	0.0635
38	15	5	518500	2592.5	CP-OFDM QPSK	1@1	21.87	17.97	0.0627



38	15	5	518500	2592.5	CP-OFDM QPSK	1@23	21.89	17.99	0.0630
38	15	5	523500	2617.5	DFT-s-OFDM PI/2 BPSK	12@6	23.4	19.5	0.0891
38	15	5	523500	2617.5	DFT-s-OFDM PI/2 BPSK	1@1	23.35	19.45	0.0881
38	15	5	523500	2617.5	DFT-s-OFDM PI/2 BPSK	1@23	23.38	19.48	0.0887
38	15	5	523500	2617.5	DFT-s-OFDM QPSK	12@6	23.39	19.49	0.0889
38	15	5	523500	2617.5	DFT-s-OFDM QPSK	1@1	23.4	19.5	0.0891
38	15	5	523500	2617.5	DFT-s-OFDM QPSK	1@23	23.42	19.52	0.0895
38	15	5	523500	2617.5	DFT-s-OFDM 16 QAM	12@6	22.4	18.5	0.0708
38	15	5	523500	2617.5	DFT-s-OFDM 16 QAM	1@1	22.35	18.45	0.0700
38	15	5	523500	2617.5	DFT-s-OFDM 16 QAM	1@23	22.35	18.45	0.0700
38	15	5	523500	2617.5	DFT-s-OFDM 64 QAM	12@6	20.9	17	0.0501
38	15	5	523500	2617.5	DFT-s-OFDM 64 QAM	1@1	21.05	17.15	0.0519
38	15	5	523500	2617.5	DFT-s-OFDM 64 QAM	1@23	21.13	17.23	0.0528
38	15	5	523500	2617.5	DFT-s-OFDM 256 QAM	12@6	19.03	15.13	0.0326
38	15	5	523500	2617.5	DFT-s-OFDM 256 QAM	1@1	18.86	14.96	0.0313
38	15	5	523500	2617.5	DFT-s-OFDM 256 QAM	1@23	18.92	15.02	0.0318
38	15	5	523500	2617.5	CP-OFDM QPSK	13@6	22.02	18.12	0.0649
38	15	5	523500	2617.5	CP-OFDM QPSK	1@1	21.8	17.9	0.0617
38	15	5	523500	2617.5	CP-OFDM QPSK	1@23	21.92	18.02	0.0634



FR1 N38(BW 5M)

Peak to Average Ratio

NR Band	SCS (kHz)	Bandwidth (MHz)	Arfcn	Freq (MHz)	Modulation	RB	Result (dB)	Limit (dB)	Verdict
38	15	5	518500	2592.5	DFT-s-OFDM PI/2 BPSK	25@0	4.1	13	PASS
38	15	5	518500	2592.5	DFT-s-OFDM QPSK	25@0	5.05	13	PASS



N38(5M)_DFT-s-OFDM_PI_2-
BPSK_Outer_Full_Mid_CH



N38(5M)_DFT-s-
OFDM_QPSK_Outer_Full_Mid_CH





Occupied Bandwidth

NR Band	SCS (kHz)	Bandwidth (MHz)	Arfcn	Freq (MHz)	Modulation	RB	OBW (MHz)	26dB BW (MHz)
38	15	5	518500	2592.5	CP-OFDM QPSK	25@0	4.4762	4.929
38	15	5	518500	2592.5	CP-OFDM 16 QAM	25@0	4.4662	4.792
38	15	5	518500	2592.5	CP-OFDM 64 QAM	25@0	4.4598	4.75
38	15	5	518500	2592.5	CP-OFDM 256 QAM	25@0	4.4573	4.767



N38(5M)_CP-OFDM_QPSK_Outer_Full_Mid_CH

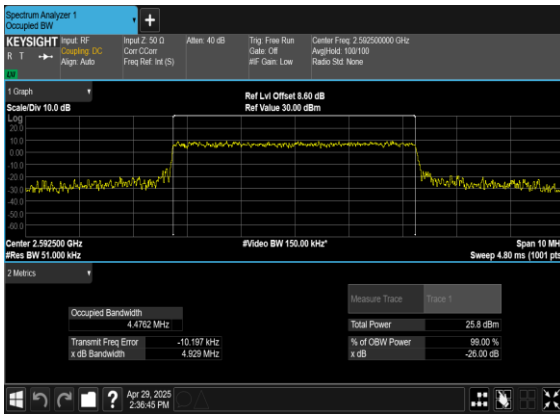

N38(5M)_CP-OFDM_16QAM_Outer_Full_Mid_CH

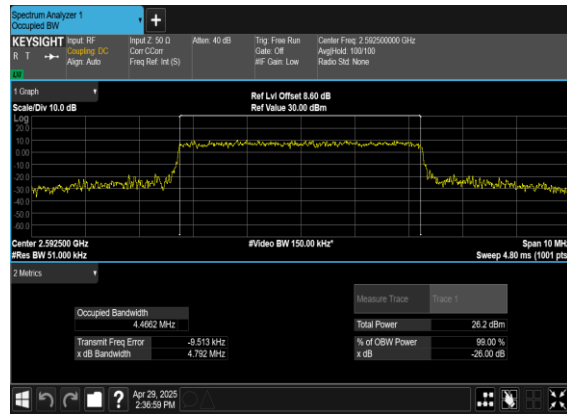

N38(5M)_CP-OFDM_64QAM_Outer_Full_Mid_CH

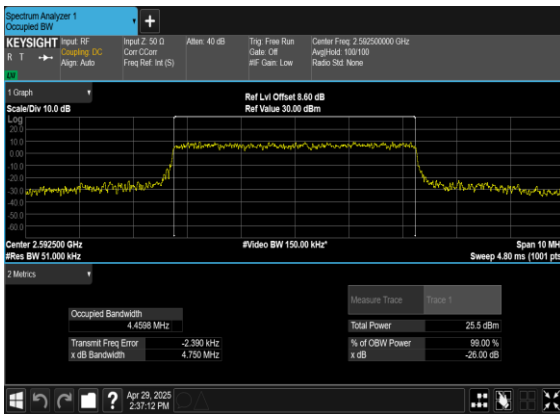

N38(5M)_CP-OFDM_256QAM_Outer_Full_Mid_CH

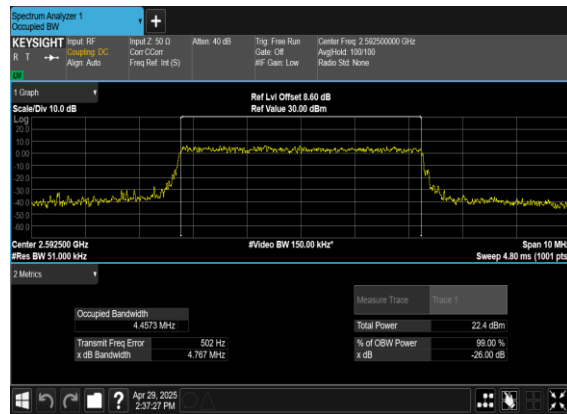



Conducted Spurious Emissions

NR Band	SCS (kHz)	Bandwidth (MHz)	Arfcn	Freq (MHz)	Modulation	RB	Result	Verdict
38	15	5	514500	2572.5	DFT-s-OFDM BPSK	1@0	see graph	---
38	15	5	514500	2572.5	DFT-s-OFDM BPSK	1@0	see graph	PASS
38	15	5	514500	2572.5	DFT-s-OFDM BPSK	1@0	see graph	PASS
38	15	5	514500	2572.5	DFT-s-OFDM QPSK	1@0	see graph	---
38	15	5	514500	2572.5	DFT-s-OFDM QPSK	1@0	see graph	PASS
38	15	5	514500	2572.5	DFT-s-OFDM QPSK	1@0	see graph	PASS
38	15	5	518500	2592.5	DFT-s-OFDM BPSK	1@0	see graph	---
38	15	5	518500	2592.5	DFT-s-OFDM BPSK	1@0	see graph	PASS
38	15	5	518500	2592.5	DFT-s-OFDM BPSK	1@0	see graph	PASS
38	15	5	518500	2592.5	DFT-s-OFDM QPSK	1@0	see graph	---
38	15	5	518500	2592.5	DFT-s-OFDM QPSK	1@0	see graph	PASS
38	15	5	518500	2592.5	DFT-s-OFDM QPSK	1@0	see graph	PASS
38	15	5	523500	2617.5	DFT-s-OFDM BPSK	1@0	see graph	---
38	15	5	523500	2617.5	DFT-s-OFDM BPSK	1@0	see graph	PASS
38	15	5	523500	2617.5	DFT-s-OFDM BPSK	1@0	see graph	PASS
38	15	5	523500	2617.5	DFT-s-OFDM QPSK	1@0	see graph	---
38	15	5	523500	2617.5	DFT-s-OFDM QPSK	1@0	see graph	PASS
38	15	5	523500	2617.5	DFT-s-OFDM QPSK	1@0	see graph	PASS



N38(5M)_DFT-s-OFDM_BPSK_Edge_1RB_Left_Low_CH



N38(5M)_DFT-s-OFDM_BPSK_Edge_1RB_Left_Low_CH

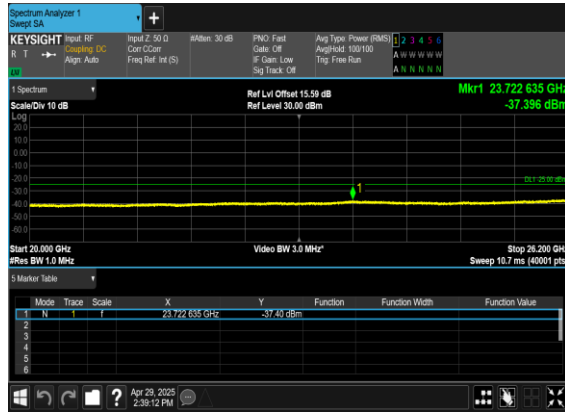

N38(5M)_DFT-s-OFDM_QPSK_Edge_1RB_Left_Low_CH

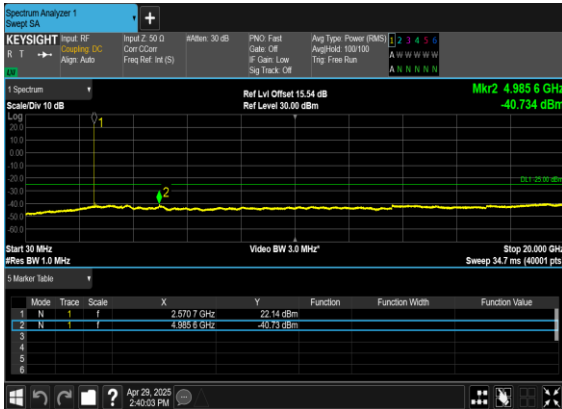

N38(5M)_DFT-s-OFDM_QPSK_Edge_1RB_Left_Low_CH

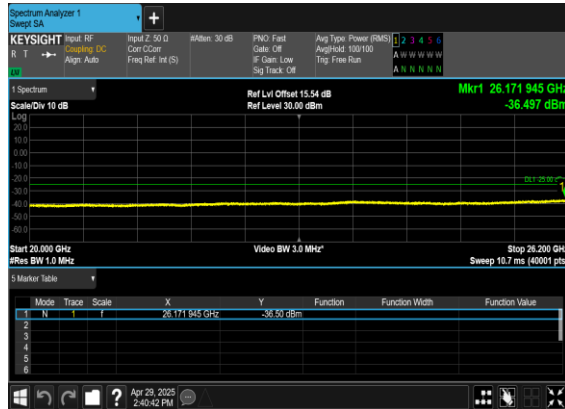



N38(5M)_DFT-s-OFDM_BPSK_Edge_1RB_Left_Mid_CH

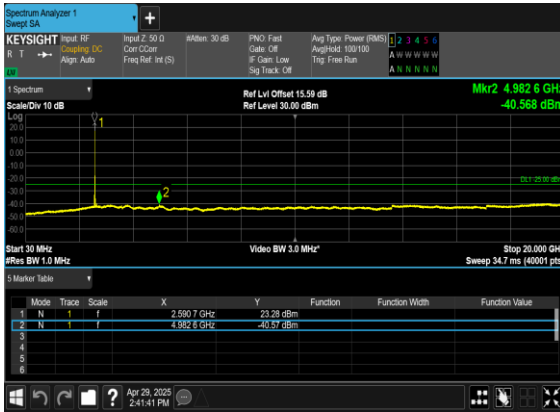

N38(5M)_DFT-s-OFDM_BPSK_Edge_1RB_Left_Mid_CH

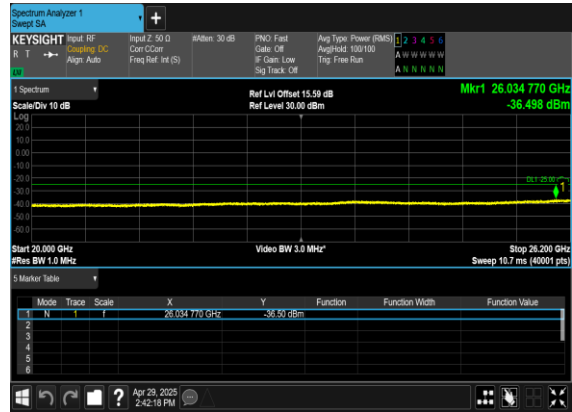

N38(5M)_DFT-s-OFDM_QPSK_Edge_1RB_Left_Mid_CH



N38(5M)_DFT-s-OFDM_QPSK_Edge_1RB_Left_Mid_CH

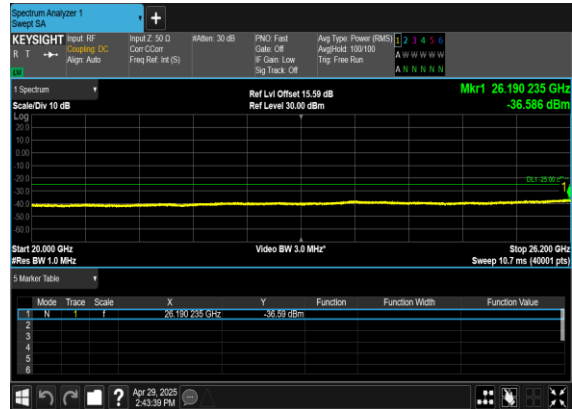



N38(5M)_DFT-s-OFDM_BPSK_Edge_1RB_Left_High_CH

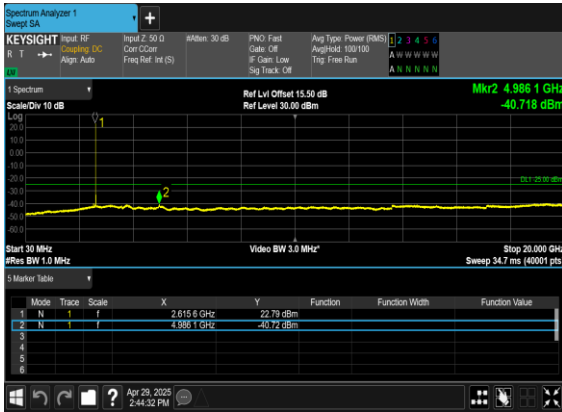

N38(5M)_DFT-s-OFDM_BPSK_Edge_1RB_Left_High_CH

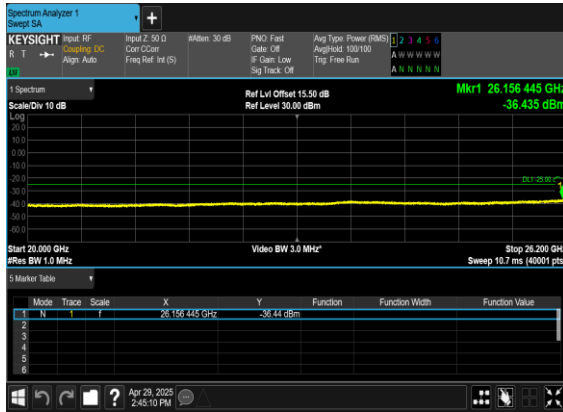

N38(5M)_DFT-s-OFDM_QPSK_Edge_1RB_Left_High_CH

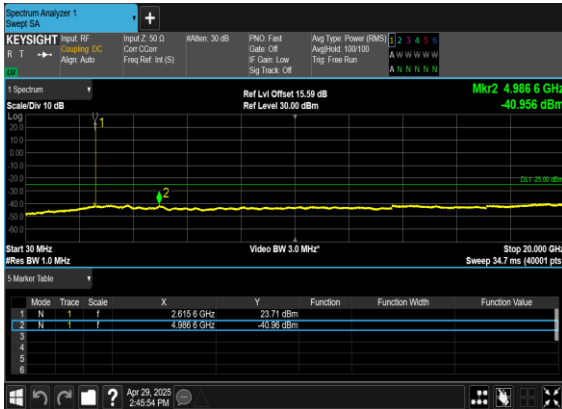

N38(5M)_DFT-s-OFDM_QPSK_Edge_1RB_Left_High_CH

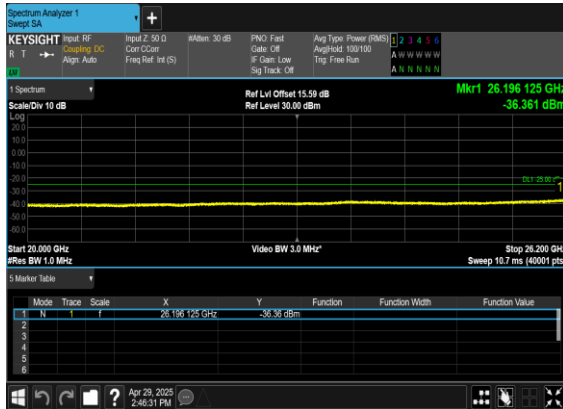



Conducted Band Edge

NR Band	SCS (kHz)	Bandwidth (MHz)	Arfcn	Freq (MHz)	Modulation	RB	Result	Verdict
38	15	5	514500	2572.5	DFT-s-OFDM BPSK	1@0	see graph	PASS
38	15	5	514500	2572.5	DFT-s-OFDM QPSK	1@0	see graph	PASS
38	15	5	514500	2572.5	DFT-s-OFDM BPSK	25@0	see graph	PASS
38	15	5	514500	2572.5	DFT-s-OFDM QPSK	25@0	see graph	PASS
38	15	5	523500	2617.5	DFT-s-OFDM BPSK	1@24	see graph	PASS
38	15	5	523500	2617.5	DFT-s-OFDM QPSK	1@24	see graph	PASS
38	15	5	523500	2617.5	DFT-s-OFDM BPSK	25@0	see graph	PASS
38	15	5	523500	2617.5	DFT-s-OFDM QPSK	25@0	see graph	PASS



N38(5M)_DFT-s-OFDM_BPSK_Edge_1RB_Left_Low_CH

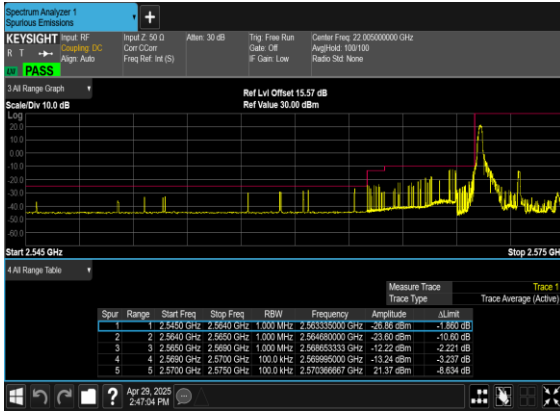

N38(5M)_DFT-s-OFDM_QPSK_Edge_1RB_Left_Low_CH

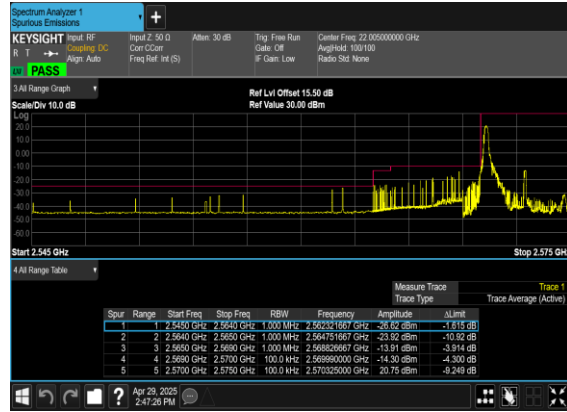

N38(5M)_DFT-s-OFDM_BPSK_Outer_Full_Low_CH

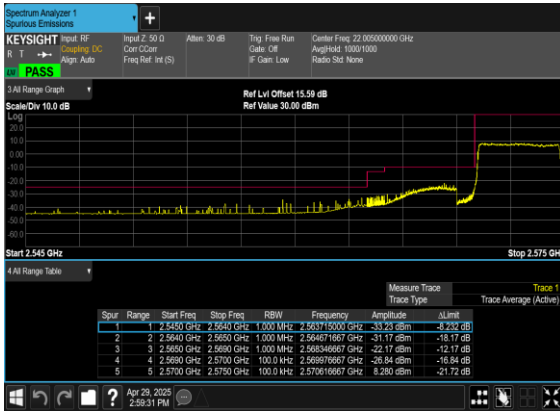

N38(5M)_DFT-s-OFDM_QPSK_Outer_Full_Low_CH

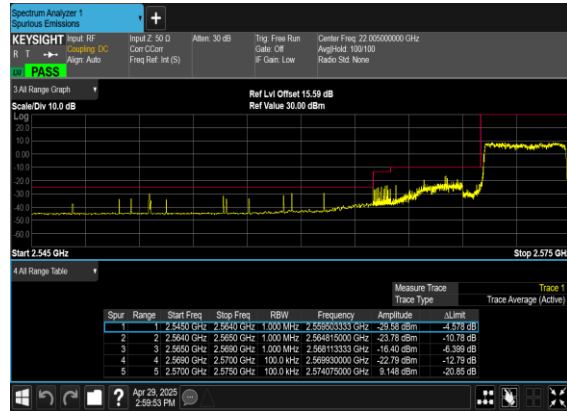



N38(5M)_DFT-s-OFDM_BPSK_Edge_1RB_Right_High_CH



N38(5M)_DFT-s-OFDM_QPSK_Edge_1RB_Right_High_CH

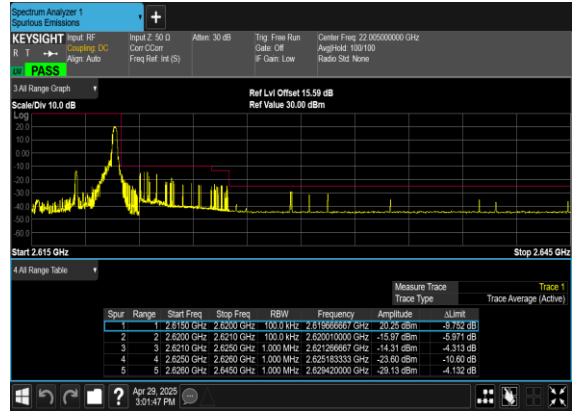

N38(5M)_DFT-s-OFDM_BPSK_Outer_Full_High_CH



N38(5M)_DFT-s-OFDM_QPSK_Outer_Full_High_CH

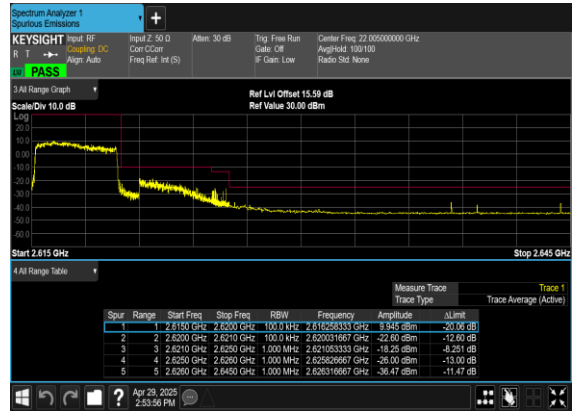



Software Version: 23.06.1602

FR1 N38 ANT4(Other PA)

LTE Band: 2, LTE BW: 10M, LTE ARFCN: Mid

Transmitter Conducted Output Power And EIRP, (G_T - L_c)= -4.1dBi

NR Band	SCS	Band Width	Arfcn	Freq (MHz)	Modulation	RB	Conducted Power(dBm)	EIRP (dBm)	EIRP (W)
38	15	5	514500	2572.5	DFT-s-OFDM PI/2 BPSK	12@6	22.72	18.62	0.0728
38	15	5	514500	2572.5	DFT-s-OFDM PI/2 BPSK	1@1	22.58	18.48	0.0705
38	15	5	514500	2572.5	DFT-s-OFDM PI/2 BPSK	1@23	22.6	18.5	0.0708
38	15	5	514500	2572.5	DFT-s-OFDM QPSK	12@6	22.84	18.74	0.0748
38	15	5	514500	2572.5	DFT-s-OFDM QPSK	1@1	22.72	18.62	0.0728
38	15	5	514500	2572.5	DFT-s-OFDM QPSK	1@23	22.81	18.71	0.0743
38	15	5	514500	2572.5	DFT-s-OFDM 16 QAM	12@6	21.77	17.67	0.0585
38	15	5	514500	2572.5	DFT-s-OFDM 16 QAM	1@1	22.12	18.02	0.0634
38	15	5	514500	2572.5	DFT-s-OFDM 16 QAM	1@23	22.18	18.08	0.0643
38	15	5	514500	2572.5	DFT-s-OFDM 64 QAM	12@6	20.31	16.21	0.0418
38	15	5	514500	2572.5	DFT-s-OFDM 64 QAM	1@1	20.56	16.46	0.0443
38	15	5	514500	2572.5	DFT-s-OFDM 64 QAM	1@23	20.7	16.6	0.0457
38	15	5	514500	2572.5	DFT-s-OFDM 256 QAM	12@6	18.45	14.35	0.0272
38	15	5	514500	2572.5	DFT-s-OFDM 256 QAM	1@1	18.17	14.07	0.0255
38	15	5	514500	2572.5	DFT-s-OFDM 256 QAM	1@23	18.19	14.09	0.0256
38	15	5	514500	2572.5	CP-OFDM QPSK	13@6	21.26	17.16	0.0520
38	15	5	514500	2572.5	CP-OFDM QPSK	1@1	21.34	17.24	0.0530
38	15	5	514500	2572.5	CP-OFDM QPSK	1@23	21.42	17.32	0.0540
38	15	5	518500	2592.5	DFT-s-OFDM PI/2 BPSK	12@6	22.69	18.59	0.0723
38	15	5	518500	2592.5	DFT-s-OFDM PI/2 BPSK	1@1	22.5	18.4	0.0692
38	15	5	518500	2592.5	DFT-s-OFDM PI/2 BPSK	1@23	22.54	18.44	0.0698
38	15	5	518500	2592.5	DFT-s-OFDM QPSK	12@6	22.81	18.71	0.0743
38	15	5	518500	2592.5	DFT-s-OFDM QPSK	1@1	22.78	18.68	0.0738
38	15	5	518500	2592.5	DFT-s-OFDM QPSK	1@23	22.83	18.73	0.0746
38	15	5	518500	2592.5	DFT-s-OFDM 16 QAM	12@6	21.76	17.66	0.0583
38	15	5	518500	2592.5	DFT-s-OFDM 16 QAM	1@1	22.3	18.2	0.0661
38	15	5	518500	2592.5	DFT-s-OFDM 16 QAM	1@23	22.32	18.22	0.0664
38	15	5	518500	2592.5	DFT-s-OFDM 64 QAM	12@6	20.33	16.23	0.0420
38	15	5	518500	2592.5	DFT-s-OFDM 64 QAM	1@1	20.72	16.62	0.0459
38	15	5	518500	2592.5	DFT-s-OFDM 64 QAM	1@23	20.74	16.64	0.0461
38	15	5	518500	2592.5	DFT-s-OFDM 256 QAM	12@6	18.44	14.34	0.0272
38	15	5	518500	2592.5	DFT-s-OFDM 256 QAM	1@1	18.18	14.08	0.0256
38	15	5	518500	2592.5	DFT-s-OFDM 256 QAM	1@23	18.17	14.07	0.0255



38	15	5	518500	2592.5	CP-OFDM QPSK	13@6	21.3	17.2	0.0525
38	15	5	518500	2592.5	CP-OFDM QPSK	1@1	21.52	17.42	0.0552
38	15	5	518500	2592.5	CP-OFDM QPSK	1@23	21.58	17.48	0.0560
38	15	5	523500	2617.5	DFT-s-OFDM PI/2 BPSK	12@6	22.73	18.63	0.0729
38	15	5	523500	2617.5	DFT-s-OFDM PI/2 BPSK	1@1	22.54	18.44	0.0698
38	15	5	523500	2617.5	DFT-s-OFDM PI/2 BPSK	1@23	22.63	18.53	0.0713
38	15	5	523500	2617.5	DFT-s-OFDM QPSK	12@6	22.89	18.79	0.0757
38	15	5	523500	2617.5	DFT-s-OFDM QPSK	1@1	22.81	18.71	0.0743
38	15	5	523500	2617.5	DFT-s-OFDM QPSK	1@23	22.91	18.81	0.0760
38	15	5	523500	2617.5	DFT-s-OFDM 16 QAM	12@6	21.81	17.71	0.0590
38	15	5	523500	2617.5	DFT-s-OFDM 16 QAM	1@1	22.34	18.24	0.0667
38	15	5	523500	2617.5	DFT-s-OFDM 16 QAM	1@23	22.34	18.24	0.0667
38	15	5	523500	2617.5	DFT-s-OFDM 64 QAM	12@6	20.36	16.26	0.0423
38	15	5	523500	2617.5	DFT-s-OFDM 64 QAM	1@1	20.73	16.63	0.0460
38	15	5	523500	2617.5	DFT-s-OFDM 64 QAM	1@23	20.79	16.69	0.0467
38	15	5	523500	2617.5	DFT-s-OFDM 256 QAM	12@6	18.48	14.38	0.0274
38	15	5	523500	2617.5	DFT-s-OFDM 256 QAM	1@1	18.29	14.19	0.0262
38	15	5	523500	2617.5	DFT-s-OFDM 256 QAM	1@23	18.35	14.25	0.0266
38	15	5	523500	2617.5	CP-OFDM QPSK	13@6	21.35	17.25	0.0531
38	15	5	523500	2617.5	CP-OFDM QPSK	1@1	21.53	17.43	0.0553
38	15	5	523500	2617.5	CP-OFDM QPSK	1@23	21.63	17.53	0.0566



Peak to Average Ratio

NR Band	SCS (kHz)	Bandwidth (MHz)	Arfcn	Freq (MHz)	Modulation	RB	Result (dB)	Limit (dB)	Verdict
38	15	5	518500	2592.5	DFT-s-OFDM PI/2 BPSK	25@0	3.1	13	PASS
38	15	5	518500	2592.5	DFT-s-OFDM QPSK	25@0	3.89	13	PASS



B2_N38(5M)_DFT-s-OFDM_PI_2-BPSK_Outer_Full_Mid_CH



B2_N38(5M)_DFT-s-OFDM_QPSK_Outer_Full_Mid_CH





Occupied Bandwidth

NR Band	SCS (kHz)	Bandwidth (MHz)	Arfcn	Freq (MHz)	Modulation	RB	OBW (MHz)	26dB BW (MHz)
38	15	5	518500	2592.5	CP-OFDM QPSK	25@0	4.4684	4.717
38	15	5	518500	2592.5	CP-OFDM 16 QAM	25@0	4.466	4.786
38	15	5	518500	2592.5	CP-OFDM 64 QAM	25@0	4.4537	4.748
38	15	5	518500	2592.5	CP-OFDM 256 QAM	25@0	4.465	4.759



B2_N38 (5M)_CP-OFDM_QPSK_Outer_Full_Mid_CH

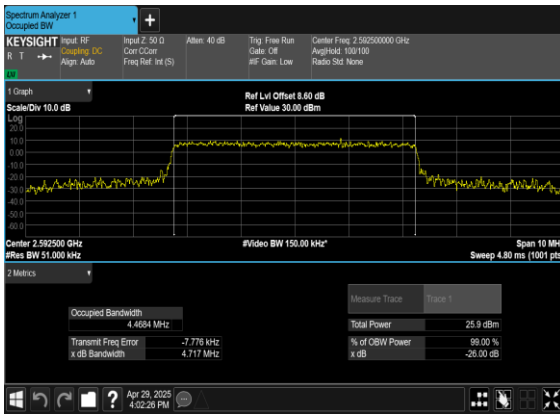

B2_N38 (5M)_CP-OFDM_16 QAM_Outer_Full_Mid_CH

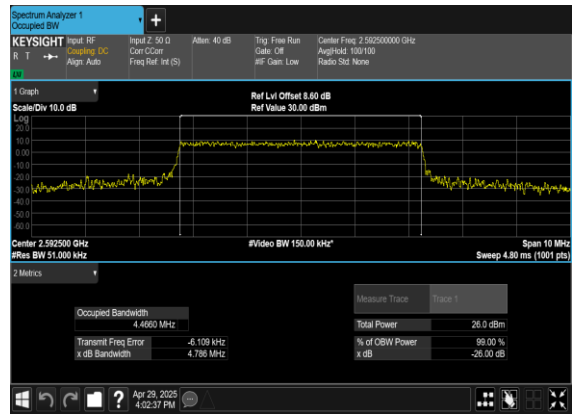

B2_N38 (5M)_CP-OFDM_64 QAM_Outer_Full_Mid_CH

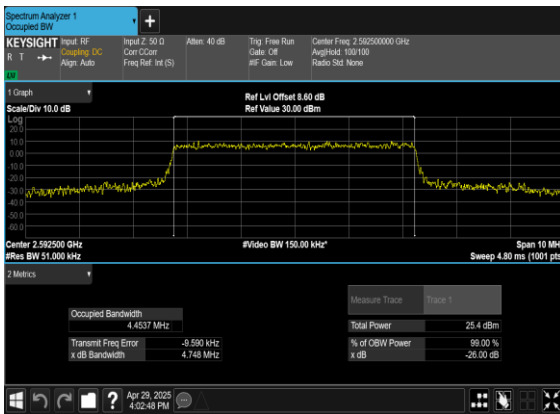

B2_N38 (5M)_CP-OFDM_256 QAM_Outer_Full_Mid_CH





Conducted Spurious Emissions

NR Band	SCS (kHz)	Bandwidth (MHz)	Arfcn	Freq (MHz)	Modulation	RB	Result	Verdict
38	15	5	514500	2572.5	DFT-s-OFDM BPSK	1@0	see graph	---
38	15	5	514500	2572.5	DFT-s-OFDM BPSK	1@0	see graph	PASS
38	15	5	514500	2572.5	DFT-s-OFDM BPSK	1@0	see graph	PASS
38	15	5	514500	2572.5	DFT-s-OFDM QPSK	1@0	see graph	---
38	15	5	514500	2572.5	DFT-s-OFDM QPSK	1@0	see graph	PASS
38	15	5	514500	2572.5	DFT-s-OFDM QPSK	1@0	see graph	PASS
38	15	5	518500	2592.5	DFT-s-OFDM BPSK	1@0	see graph	---
38	15	5	518500	2592.5	DFT-s-OFDM BPSK	1@0	see graph	PASS
38	15	5	518500	2592.5	DFT-s-OFDM BPSK	1@0	see graph	PASS
38	15	5	518500	2592.5	DFT-s-OFDM QPSK	1@0	see graph	---
38	15	5	518500	2592.5	DFT-s-OFDM QPSK	1@0	see graph	PASS
38	15	5	518500	2592.5	DFT-s-OFDM QPSK	1@0	see graph	PASS
38	15	5	523500	2617.5	DFT-s-OFDM BPSK	1@0	see graph	---
38	15	5	523500	2617.5	DFT-s-OFDM BPSK	1@0	see graph	PASS
38	15	5	523500	2617.5	DFT-s-OFDM BPSK	1@0	see graph	PASS
38	15	5	523500	2617.5	DFT-s-OFDM QPSK	1@0	see graph	---
38	15	5	523500	2617.5	DFT-s-OFDM QPSK	1@0	see graph	PASS
38	15	5	523500	2617.5	DFT-s-OFDM QPSK	1@0	see graph	PASS



B2_N38(5M)_DFT-s-OFDM_BPSK_Edge_1RB_Left_Low_CH

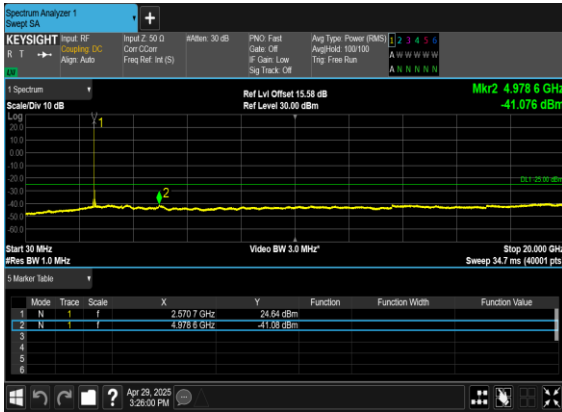

B2_N38(5M)_DFT-s-OFDM_BPSK_Edge_1RB_Left_Low_CH

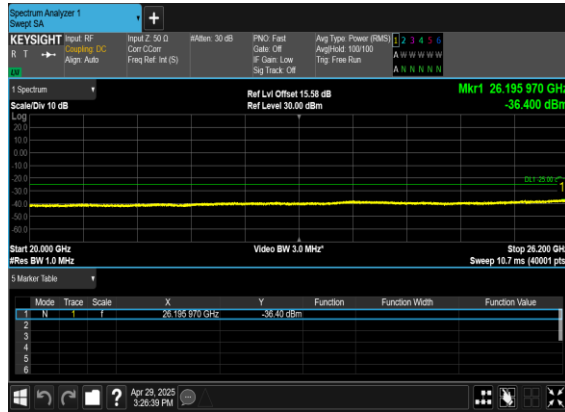

B2_N38(5M)_DFT-s-OFDM_QPSK_Edge_1RB_Left_Low_CH

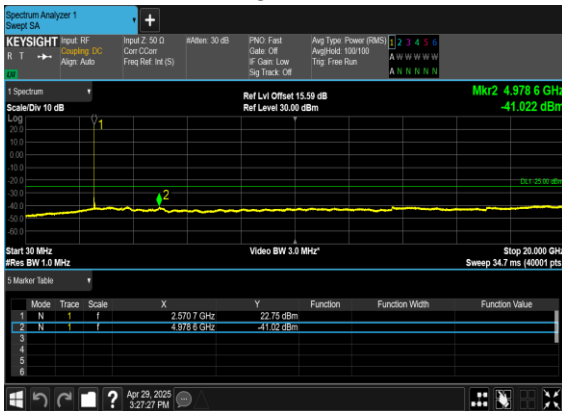

B2_N38(5M)_DFT-s-OFDM_QPSK_Edge_1RB_Left_Low_CH

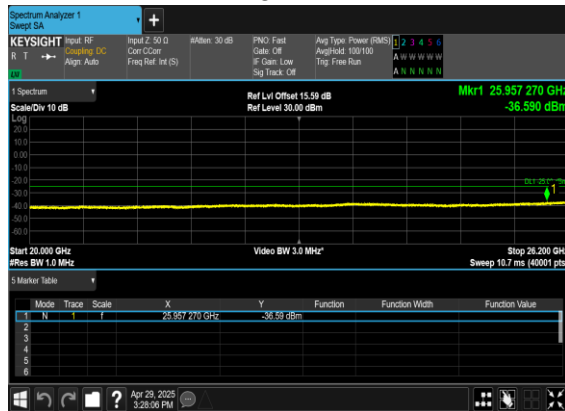



B2_N38(5M)_DFT-s-OFDM_BPSK_Edge_1RB_Left_Mid_CH



B2_N38(5M)_DFT-s-OFDM_BPSK_Edge_1RB_Left_Mid_CH

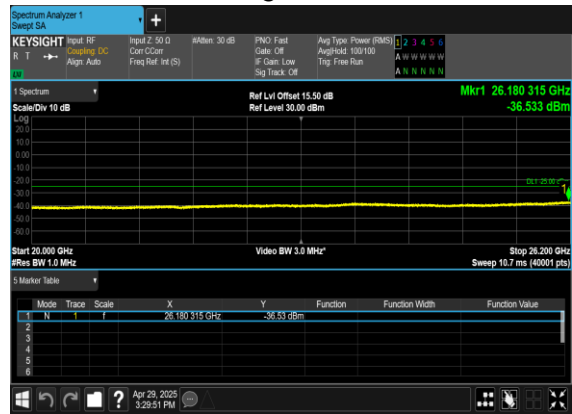

B2_N38(5M)_DFT-s-OFDM_QPSK_Edge_1RB_Left_Mid_CH

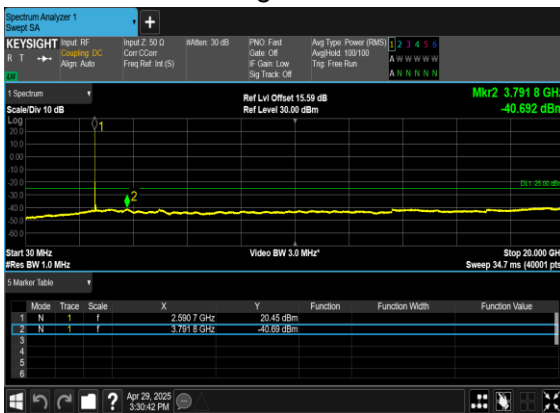

B2_N38(5M)_DFT-s-OFDM_QPSK_Edge_1RB_Left_Mid_CH

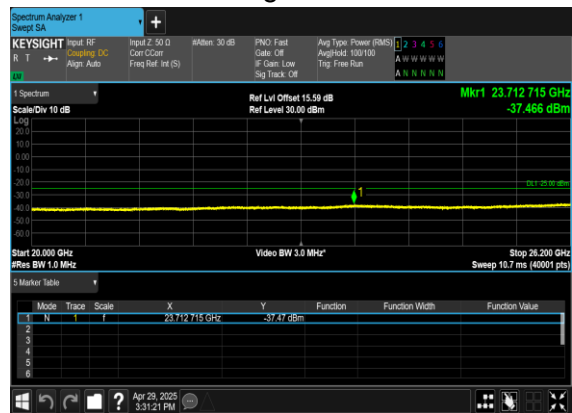



B2_N38(5M)_DFT-s-OFDM_BPSK_Edge_1RB_Left_High_CH



B2_N38(5M)_DFT-s-OFDM_BPSK_Edge_1RB_Left_High_CH

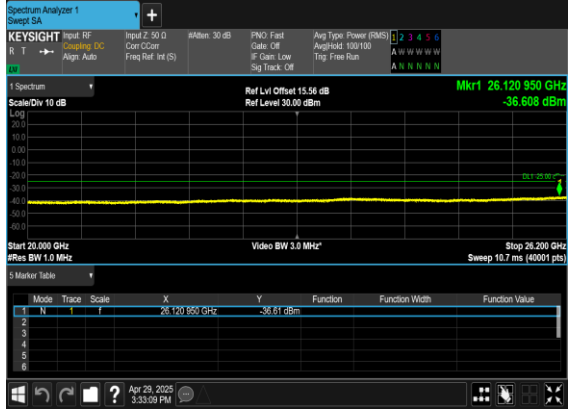

B2_N38(5M)_DFT-s-OFDM_QPSK_Edge_1RB_Left_High_CH



B2_N38(5M)_DFT-s-OFDM_QPSK_Edge_1RB_Left_High_CH

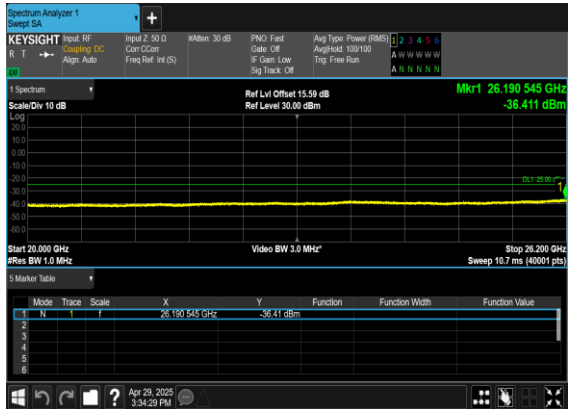



Conducted Band Edge

NR Band	SCS (kHz)	Bandwidth (MHz)	Arfcn	Freq (MHz)	Modulation	RB	Result	Verdict
38	15	5	514500	2572.5	DFT-s-OFDM BPSK	1@0	see graph	PASS
38	15	5	514500	2572.5	DFT-s-OFDM QPSK	1@0	see graph	PASS
38	15	5	514500	2572.5	DFT-s-OFDM BPSK	25@0	see graph	PASS
38	15	5	514500	2572.5	DFT-s-OFDM QPSK	25@0	see graph	PASS
38	15	5	523500	2617.5	DFT-s-OFDM BPSK	1@24	see graph	PASS
38	15	5	523500	2617.5	DFT-s-OFDM QPSK	1@24	see graph	PASS
38	15	5	523500	2617.5	DFT-s-OFDM BPSK	25@0	see graph	PASS
38	15	5	523500	2617.5	DFT-s-OFDM QPSK	25@0	see graph	PASS



B2_N38(5M)_DFT-s-OFDM_BPSK_Edge_1RB_Left_Low_CH

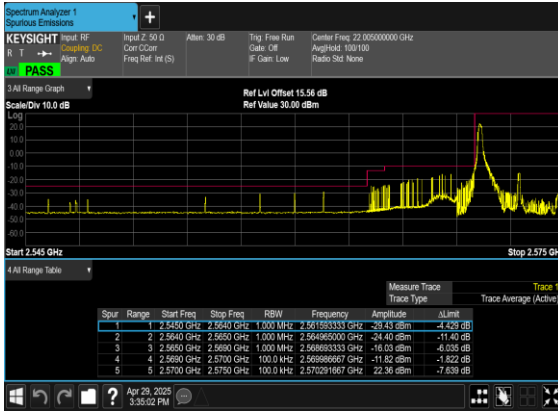

B2_N38(5M)_DFT-s-OFDM_QPSK_Edge_1RB_Left_Low_CH

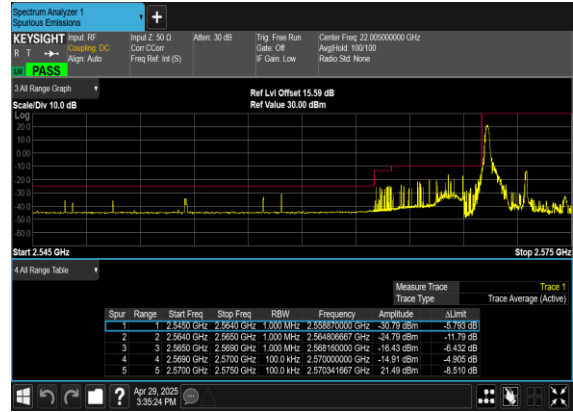

B2_N38(5M)_DFT-s-OFDM_BPSK_Outer_Full_Low_CH

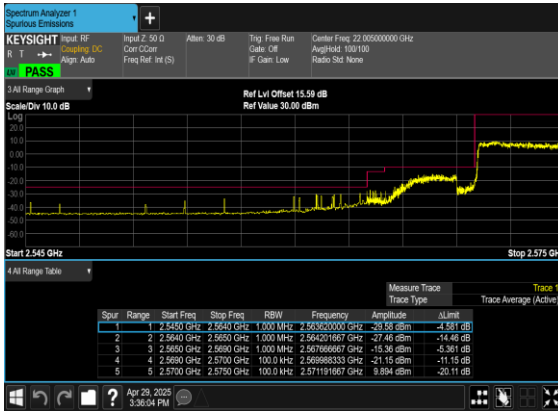

B2_N38(5M)_DFT-s-OFDM_QPSK_Outer_Full_Low_CH

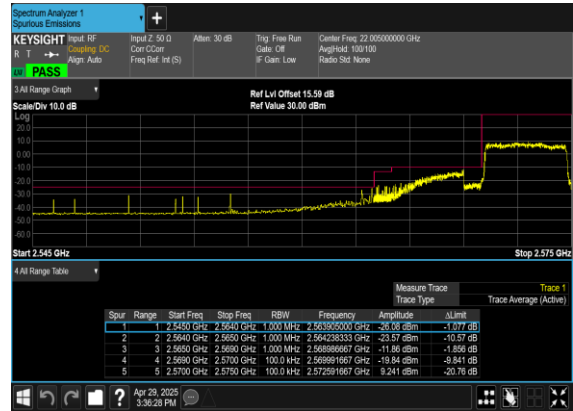



B2_N38(5M)_DFT-s-OFDM_BPSK_Edge_1RB_Right_High_CH

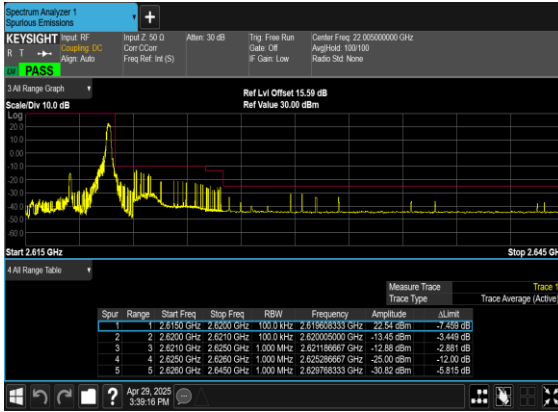

B2_N38(5M)_DFT-s-OFDM_QPSK_Edge_1RB_Right_High_CH

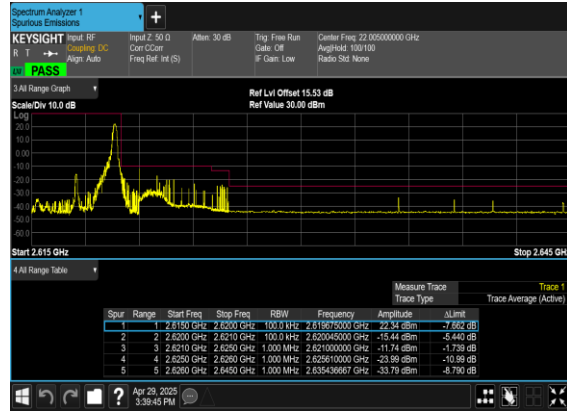

B2_N38(5M)_DFT-s-OFDM_BPSK_Outer_Full_High_CH

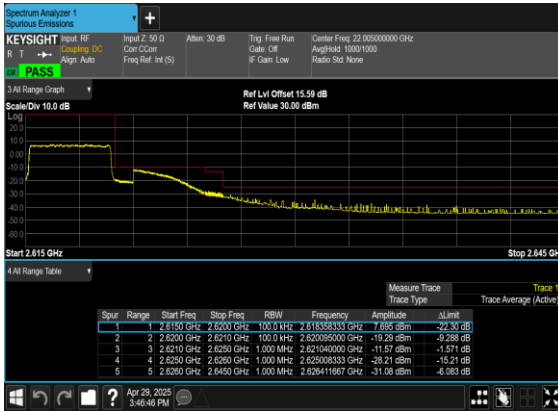

B2_N38(5M)_DFT-s-OFDM_QPSK_Outer_Full_High_CH

