



FCC RF Test Report

APPLICANT : Motorola Mobility LLC
EQUIPMENT : Mobile Cellular Phone
BRAND NAME : Motorola
MODEL NAME : XT2519-1, XT2519-2, XT2519V
FCC ID : IHDT56AU6
STANDARD : 47 CFR Part 27
CLASSIFICATION : PCS Licensed Transmitter Held to Ear (PCE)
TEST DATE(S) : Jan. 20, 2025 ~ Feb. 17, 2025

We, Sporton International Inc. (Kunshan), would like to declare that the tested sample has been evaluated in accordance with the procedures given in ANSI C63.26-2015 and shown compliance with the applicable technical standards.

This report contains data that were produced under subcontract by Sporton International Inc. (ShenZhen)

The test results in this report apply exclusively to the tested model / sample. Without written approval of Sporton International Inc. (Kunshan), the test report shall not be reproduced except in full.

Jason Jia

Approved by: Jason Jia



Sporton International Inc. (Kunshan)

**No. 1098, Pengxi North Road, Kunshan Economic Development Zone Jiangsu Province 215300
People's Republic of China**



TABLE OF CONTENTS

REVISION HISTORY...3
SUMMARY OF TEST RESULT...4
1 GENERAL DESCRIPTION...5
1.1 Applicant...5
1.2 Manufacturer...5
1.3 Product Feature of Equipment Under Test...5
1.4 Product Specification of Equipment Under Test...5
1.5 Modification of EUT...6
1.6 Maximum ERP/EIRP and Emission Designator...7
1.7 Testing Location...9
1.8 Test Software...9
1.9 Applicable Standards...10
1.10 Specification of Accessory...10
2 TEST CONFIGURATION OF EQUIPMENT UNDER TEST...11
2.1 Test Mode...11
2.2 Connection Diagram of Test System...13
2.3 Support Unit used in test configuration and system...13
2.4 Measurement Results Explanation Example...14
2.5 Frequency List of Low/Middle/High Channels...14
3 CONDUCTED TEST ITEMS...16
3.1 Measuring Instruments...16
3.2 Test Setup...16
3.3 Test Result of Conducted Test...16
3.4 Conducted Output Power and ERP/EIRP...17
3.5 Peak-to-Average Ratio...18
3.6 Occupied Bandwidth...19
3.7 Conducted Band Edge...20
3.8 Conducted Spurious Emission...21
3.9 Frequency Stability...22
4 RADIATED TEST ITEMS...23
4.1 Measuring Instruments...23
4.2 Test Setup...23
4.3 Test Result of Radiated Test...24
4.4 Radiated Spurious Emission...25
5 LIST OF MEASURING EQUIPMENT...26
6 MEASUREMENT UNCERTAINTY...27
APPENDIX A. TEST RESULTS OF CONDUCTED TEST
APPENDIX B. TEST RESULTS OF RADIATED TEST
APPENDIX C. TEST SETUP PHOTOGRAPHS



SUMMARY OF TEST RESULT

Report Section	FCC Rule	Description	Limit	Result	Remark
3.4	§2.1046	Conducted Output Power	Reporting Only	PASS	-
	§27.50(c)(10)	Effective Radiated Power (5G NR n12, n71)	ERP < 3 Watt		
	§27.50(d)(4)	Equivalent Isotropic Radiated Power (5G NR n66, n70)	EIRP < 1Watt		
3.5	N/A	Peak-to-Average Ratio	<13 dB	PASS	-
3.6	§2.1049	Occupied Bandwidth	Reporting Only	PASS	-
3.7	§2.1051 §27.53(h) §27.53(g)	Conducted Band Edge Measurement (5G NR n66, n70) (5G NR n12, n71)	< 43+10log10(P[Watts])	PASS	-
3.8	§2.1051 §27.53(h) §27.53(g)	Conducted Spurious Emission (5G NR n66, n70) (5G NR n12, n71)	< 43+10log10(P[Watts])	PASS	-
3.9	§27.54	Frequency Stability Temperature & Voltage	Within Authorized Band	PASS	-
4.4	§2.1053 §27.53(h) §27.53(g)	Radiated Spurious Emission (5G NR n66, n70) (5G NR n12, n71)	< 43+10log ₁₀ (P[Watts])	PASS	Under limit 9.72 dB at 14464.00 MHz

Conformity Assessment Condition:
1. The test results (PASS/FAIL) with all measurement uncertainty excluded are presented against the regulation limits or in accordance with the requirements stipulated by the applicant/manufacturer who shall bear all the risks of non-compliance that may potentially occur if measurement uncertainty is taken into account.
2. The measurement uncertainty please refer to each test result in the section "Measurement Uncertainty"
Disclaimer:
The product specifications of the EUT presented in the test report that may affect the test assessments are declared by the manufacturer who shall take full responsibility for the authenticity.



1 General Description

1.1 Applicant

Motorola Mobility LLC
222 W,Merchandise Mart Plaza, Chicago IL 60654 USA

1.2 Manufacturer

Motorola Mobility LLC
222 W,Merchandise Mart Plaza, Chicago IL 60654 USA

1.3 Product Feature of Equipment Under Test

Product Feature	
Equipment	Mobile Cellular Phone
Brand Name	Motorola
Model Name	XT2519-1, XT2519-2, XT2519V
FCC ID	IHDT56AU6
IMEI Code	Conducted: 355782390039091/355782390039109 Radiation: 355782390037798/355782390037806
HW Version	DVT2
SW Version	V2VD35.27
EUT Stage	Identical Prototype

Remark:

1. The above EUT's information was declared by manufacturer. Please refer to the specifications or user's manual for more detailed description.
2. The different model name is different for market purpose.

1.4 Product Specification of Equipment Under Test

Standards-related Product Specification	
Tx Frequency	5G NR n12 : 699 MHz ~ 716 MHz 5G NR n66 : 1710 MHz ~ 1780 MHz 5G NR n70 : 1695 MHz ~ 1710 MHz 5G NR n71: 663 MHz ~ 698 MHz
Rx Frequency	5G NR n12: 729 MHz ~ 746 MHz 5G NR n66 : 2110 MHz~ 2200 MHz 5G NR n70 : 1995 MHz ~ 2020 MHz 5G NR n71: 617 MHz ~ 652 MHz
Bandwidth	n12, n70 : 5MHz / 10MHz / 15MHz n66 : 5MHz / 10MHz / 15MHz / 20MHz / 25MHz / 30MHz / 35MHz / 40MHz / 45MHz n71 : 5MHz / 10MHz / 15MHz / 20MHz / 25MHz / 30MHz / 35MHz
SCS	15kHz,
Antenna Gain	<Ant. 0> n12 : -5.2 dBi



	n66 : -2.27 dBi n70 : -2.27 dBi n71 : -5.74 dBi <Ant. 1> : n12 : -6.0 dBi n66 : -4.7 dBi n70 : -4.7 dBi n71 : -5.7 dBi <Ant. 5> : n66 : -9.5 dBi n70 : -9.5 dBi
Type of Modulation	CP-OFDM: QPSK / 16QAM / 64QAM / 256QAM DFT-s-OFDM: PI/2 BPSK / QPSK / 16QAM / 64QAM / 256QAM

Remark:

1. The maximum ERP/EIRP is calculated from max output power and max antenna gain, only the maximum ERP/EIRP are shown in the report, 5G NR n12/n66/n70/n71 for Ant. 0 and n66/n70_UL MIMO for Ant.(0+1).
2. 5G NR support SA (n12/n66/n70/n71) mode and NSA(n12/n66/n71) mode. According to the maximum power between SA and NSA mode, SA covers NSA mode for (n12/n71).
3. The device supports two PAs for 5G NR n66 (main PA and other PA), both the PAs are full tested, only the worst EIRP are shown in the report. According to the maximum power between SA and NSA mode, SA covers NSA mode for main PA, and NSA covers SA mode for other PA.
4. The device supports two PAs for 5G NR n70 (main PA and other PA), both the PAs are full tested.
5. 5G NR n66 SA mode and NSA mode supports ant.0/1.
6. 5G NR n66/n70 supports UL MIMO mode for Ant.(0+1)/Ant.(5+1), only the worst test data of Ant.(0+1) is shown in the report.
7. 5G NR n66/n70 UL MIMO mode supports PC2.
8. MIMO Antenna gain = $10 \log[(10^{G1/20} + 10^{G2/20})^2 / 2]$.
9. For n66/n70 MIMO mode, the conducted BE/Spurious are tested at single antenna port and add $10 \cdot \log(N_{ANT})$ according to KDB 662911 D01.
10. All the supported ENDC combinations are verified conducted power, only the ENDC combination with highest power are shown in the report.
11. The EN-DC mode combination could be referred to the product spec.

1.5 Modification of EUT

No modifications are made to the EUT during all test items.



1.6 Maximum ERP/EIRP and Emission Designator

5G NR n12		PI/2 BPSK / QPSK		16QAM / 64QAM / 256QAM	
BW (MHz)	Frequency Range (MHz)	Maximum ERP(W)	Emission Designator (99%OBW)	Maximum ERP(W)	Emission Designator (99%OBW)
5	701.5 ~ 713.5	0.0385	4M46G7D	0.0303	4M48W7D
10	704.0~ 711.0	0.0390	9M27G7D	0.0308	9M29W7D
15	706.5 ~ 708.5	0.0391	14M0G7D	0.0303	14M1W7D

5G NR n66		PI/2 BPSK / QPSK		16QAM / 64QAM / 256QAM	
BW (MHz)	Frequency Range (MHz)	Maximum EIRP(W)	Emission Designator (99%OBW)	Maximum EIRP(W)	Emission Designator (99%OBW)
5	1712.5 ~ 1777.5	0.1189	4M47G7D	0.0946	4M48W7D
10	1715.0 ~ 1775.0	0.1186	9M27G7D	0.0933	9M29W7D
15	1717.5 ~ 1772.5	0.1167	14M1G7D	0.0923	14M1W7D
20	1720.0 ~ 1770.0	0.1153	18M9G7D	0.0923	18M9W7D
25	1722.5 ~ 1767.5	0.1122	23M7G7D	0.0883	23M8W7D
30	1725.0 ~ 1765.0	0.1104	28M6G7D	0.0867	28M6W7D
35	1727.5 ~ 1762.5	0.1102	33M6G7D	0.0881	33M7W7D
40	1730.0 ~ 1760.0	0.1109	38M5G7D	0.0861	38M6W7D
45	1732.5 ~ 1757.5	0.1211	43M2G7D	0.0962	43M3W7D

5G NR n66 UL MIMO		PI/2 BPSK / QPSK		16QAM / 64QAM / 256QAM	
BW (MHz)	Frequency Range (MHz)	Maximum EIRP(W)	Emission Designator (99%OBW)	Maximum EIRP(W)	Emission Designator (99%OBW)
5	1712.5 ~ 1777.5	0.3177	4M45G7D	0.2399	4M47W7D
10	1715.0 ~ 1775.0	0.3192	9M27G7D	0.2415	9M28W7D
15	1717.5 ~ 1772.5	0.3184	14M1G7D	0.2393	14M1W7D
20	1720.0 ~ 1770.0	0.3170	18M9G7D	0.2399	18M9W7D
25	1722.5 ~ 1767.5	0.3055	23M7G7D	0.2317	23M8W7D
30	1725.0 ~ 1765.0	0.3062	28M6G7D	0.2307	28M6W7D
35	1727.5 ~ 1762.5	0.3041	33M6G7D	0.2328	33M5W7D
40	1730.0 ~ 1760.0	0.3034	38M5G7D	0.2312	38M6W7D
45	1732.5 ~ 1757.5	0.3199	43M2G7D	0.2382	43M2W7D



5G NR n70		PI/2 BPSK / QPSK		16QAM / 64QAM / 256QAM	
BW (MHz)	Frequency Range (MHz)	Maximum EIRP(W)	Emission Designator (99%OBW)	Maximum EIRP(W)	Emission Designator (99%OBW)
5	1697.5 ~ 1707.5	0.1197	4M46G7D	0.0923	4M47W7D
10	1700.0 ~ 1705.0	0.1191	9M28G7D	0.0938	9M29W7D
15	1702.5	0.1202	14M1G7D	0.0897	14M1W7D

5G NR n70 UL MIMO		PI/2 BPSK / QPSK		16QAM / 64QAM / 256QAM	
BW (MHz)	Frequency Range (MHz)	Maximum EIRP(W)	Emission Designator (99%OBW)	Maximum EIRP(W)	Emission Designator (99%OBW)
5	1697.5 ~ 1707.5	0.3192	4M46G7D	0.2404	4M47W7D
10	1700.0 ~ 1705.0	0.3126	9M27G7D	0.2377	9M28W7D
15	1702.5	0.3350	14M1G7D	0.2541	14M1W7D

5G NR n71		PI/2 BPSK / QPSK		16QAM / 64QAM / 256QAM	
BW (MHz)	Frequency Range (MHz)	Maximum ERP(W)	Emission Designator (99%OBW)	Maximum ERP(W)	Emission Designator (99%OBW)
5	665.5 ~ 695.5	0.0399	4M47G7D	0.0333	4M47W7D
10	668.0 ~ 693.0	0.0398	9M28G7D	0.0328	9M30W7D
15	670.5 ~ 690.5	0.0398	14M1G7D	0.0327	14M1W7D
20	673.0 ~ 688.0	0.0399	18M9G7D	0.0327	18M9W7D
25	675.5 ~ 685.5	0.0394	23M7G7D	0.0331	23M7W7D
30	678.0 ~ 683.0	0.0398	28M5G7D	0.0318	28M5W7D
35	680.5	0.0400	33M6G7D	0.0316	33M5W7D

Note: All modulations have been tested, only the worst test results of PSK & QAM are shown in the report.



1.7 Testing Location

Sporton International Inc. (Kunshan) is accredited to ISO/IEC 17025:2017 by American Association for Laboratory Accreditation with Certificate Number 5145.02.

Test Firm	Sporton International Inc. (Kunshan)		
Test Site Location	No. 1098, Pengxi North Road, Kunshan Economic Development Zone Jiangsu Province 215300 People’s Republic of China TEL : +86-512-57900158		
Test Site No.	Sporton Site No.	FCC Designation No.	FCC Test Firm Registration No.
	TH01-KS	CN1257	314309

Sporton International Inc. (ShenZhen) is accredited to ISO/IEC 17025:2017 by American Association for Laboratory Accreditation with Certificate Number 5145.01.

Test Firm	Sporton International Inc. (ShenZhen)		
Test Site Location	101, 1st Floor, Block B, Building 1, No. 2, Tengfeng 4th Road, Fenghuang Community, Fuyong Street, Baoan District, Shenzhen City, Guangdong Province 518103 People’s Republic of China TEL: +86-755-86066985		
Test Site No.	Sporton Site No.	FCC Designation No.	FCC Test Firm Registration No.
	03CH03-SZ	CN1256	421272

Test data subcontracted: Radiated Spurious Emission test case in section 4 of this report

1.8 Test Software

Item	Site	Manufacture	Name	Version
1.	03CH03-SZ	AUDIX	E3	6.2009-8-24



1.9 Applicable Standards

According to the specifications of the manufacturer, the EUT must comply with the requirements of the following standards:

- 47 CFR Part 27
- ANSI C63.26-2015
- FCC KDB 971168 D01 Power Meas License Digital Systems v03r01
- FCC KDB 412172 D01 Determining ERP and EIRP v01r01

Remark:

All test items were verified and recorded according to the standards and without any deviation during the test.

1.10 Specification of Accessory

Accessories Information				
Battery	Brand Name	Motorola(ATL)	Model Name	RM52
USB Cable 1	Brand Name	Motorola(saibao)	Model Name	SC18D86731
USB Cable 2	Brand Name	Motorola(Luxshare)	Model Name	SC18E08103



2 Test Configuration of Equipment Under Test

2.1 Test Mode

Antenna port conducted and radiated test items are performed according to KDB 971168 D01 Power Meas License Digital Systems v03r01 with maximum output power.

For radiated measurement, pre-scanned in three orthogonal panels, X, Y, Z. The worst cases (Z plane) were recorded in this report.

The device is investigated from 30MHz to 10 times of fundamental signal for radiated spurious emission test under different RB size/offset and modulations in exploratory test. Subsequently, only the worst case emissions are reported.

Orthogonal Planes of EUT	X Plane	Y Plane	Z Plane
			

Test Items	5G NR	Bandwidth (MHz)												Modulation					RB #		Test Channel			
		5	10	15	20	25	30	35	40	45	70	80	90	100	PI/2 BPSK	QPSK	16QAM	64QAM	256QAM	1	Full	L	M	H
Max. Output Power	n12	v	v	v	-	-	-	-	-	-	-	-	-	-	v	v	v	v	v	v	v	v	v	v
	n66	v	v	v	v	v	v	v	v	v	-	-	-	-	v	v	v	v	v	v	v	v	v	v
	n70	v	v	v	-	-	-	-	-	-	-	-	-	-	v	v	v	v	v	v	v	v	v	v
	n71	v	v	v	v	v	v	v	-	-	-	-	-	-	v	v	v	v	v	v	v	v	v	v
Peak-to-Average Ratio	n12		v		-	-	-	-	-	-	-	-	-	-	v	v						v		v
	n66				v						-	-	-	-	v	v						v		v
	n70		v		-	-	-	-	-	-	-	-	-	-	v	v						v		v
	n71				v				-	-	-	-	-	-	v	v						v		v
26dB and 99% Bandwidth	n12	v	v	v	-	-	-	-	-	-	-	-	-	-		v	v	v	v			v		v
	n66	v	v	v	v	v	v	v	v	v	-	-	-	-		v	v	v	v			v		v
	n70	v	v	v	-	-	-	-	-	-	-	-	-	-		v	v	v	v			v		v
	n71	v	v	v	v	v	v	v	-	-	-	-	-	-		v	v	v	v			v		v
Conducted Band Edge	n12	v	v	v	-	-	-	-	-	-	-	-	-	-	v	v				v	v	v		v
	n66	v				v				v	-	-	-	-	v	v						v		v
	n70	v	v	v	-	-	-	-	-	-	-	-	-	-	v	v						v		v
	n71	v			v			v	-	-	-	-	-	-	v	v						v		v
Conducted	n12	v	v	v	-	-	-	-	-	-	-	-	-	-	v	v				v		v	v	v



Test Items	5G NR	Bandwidth (MHz)												Modulation					RB #		Test Channel			
		5	10	15	20	25	30	35	40	45	70	80	90	100	PI/2 BPSK	QPSK	16QAM	64QAM	256QAM	1	Full	L	M	H
Spurious Emission	n66	v				v				v	-	-	-	-	v	v				v		v	v	v
	n70	v	v	v	-	-	-	-	-	-	-	-	-	-	v	v				v		v	v	v
	n71	v			v			v	-	-	-	-	-	-	v	v				v		v	v	v
Frequency Stability	n12		v		-	-	-	-	-	-	-	-	-		v					v		v		
	n66				v					-	-	-	-		v					v		v		
	n70		v		-	-	-	-	-	-	-	-	-		v					v		v		
	n71				v				-	-	-	-	-		v					v		v		
E.R.P / E.I.R.P	n12	v	v	v	-	-	-	-	-	-	-	-	-	v	v	v	v	v	v	v	v	v	v	v
	n66	v	v	v	v	v	v	v	v	v	-	-	-	-	v	v	v	v	v	v	v	v	v	v
	n70	v	v	v	-	-	-	-	-	-	-	-	-	v	v	v	v	v	v	v	v	v	v	v
	n71	v	v	v	v	v	v	v	-	-	-	-	-	v	v	v	v	v	v	v	v	v	v	v
Radiated Spurious Emission	n12	Worst Case																			v	v	v	
	n66	Worst Case																			v	v	v	
	n70	Worst Case																			v	v	v	
	n71	Worst Case																			v	v	v	
Note	1. The mark "v" means that this configuration is chosen for testing 2. The mark "-" means that this bandwidth is not supported. 3. The device is investigated from 30MHz to 10 times of fundamental signal for radiated spurious emission test under different RB size/offset and modulations in exploratory test. Subsequently, only the worst case emissions are reported. 4. Frequency Stability : Normal Voltage = 3.91V ; Low Voltage =3.60V. ; High Voltage =4.5V																							

2.2 Connection Diagram of Test System

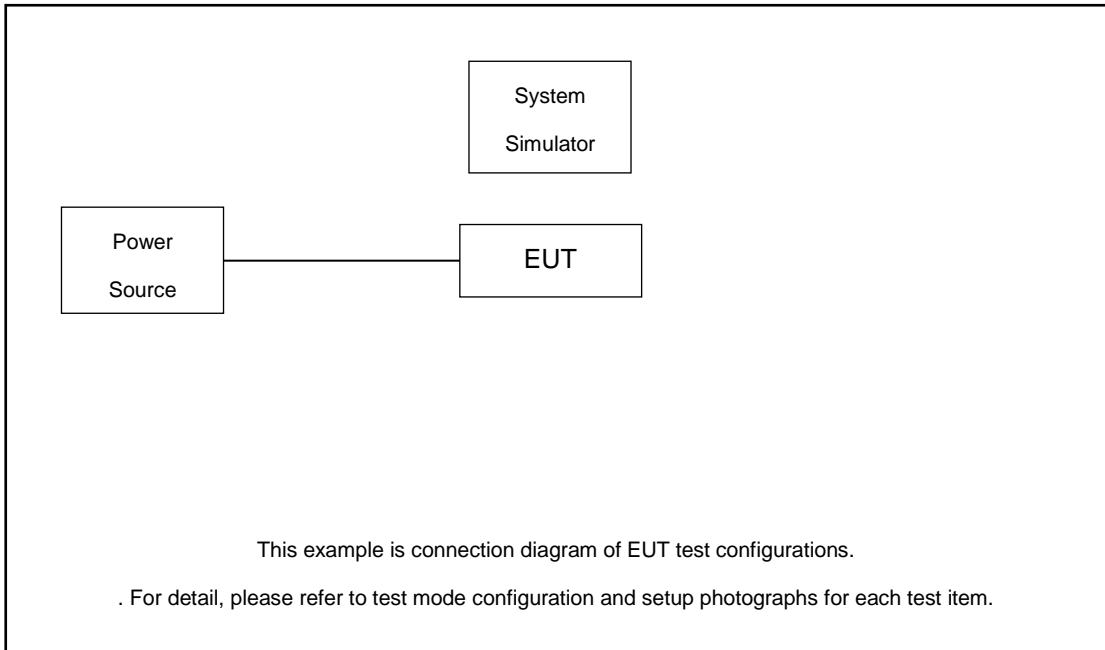

The EUT has been configuration operated in a manner tended to maximize its emission characteristics in a typical application.

2.3 Support Unit used in test configuration and system

Item	Equipment	Trade Name	Model No.	FCC ID	Data Cable	Power Cord
1.	DC Power Supply	GW	GPS-3030D	N/A	N/A	Unshielded, 1.8 m
2.	LTE Base Station	Anritsu	MT8821C	N/A	N/A	Unshielded, 1.8 m
3.	NR Base Station	Anritsu	MT8000A	N/A	N/A	Unshielded, 1.8 m



2.4 Measurement Results Explanation Example

For all conducted test items:

The offset level is set in the spectrum analyzer to compensate the RF cable loss between EUT conducted output port and spectrum analyzer. With the offset compensation, the spectrum analyzer reading level is exactly the EUT RF output level.

The spectrum analyzer offset is derived from RF cable loss.

$$\text{Offset} = \text{RF cable loss.}$$

Following shows an offset computation example with cable loss 7.5 dB.

Example :

$$\begin{aligned} \text{Offset(dB)} &= \text{RF cable loss(dB)}. \\ &= 7.5 \text{ (dB)} \end{aligned}$$

2.5 Frequency List of Low/Middle/High Channels

5G NR n12 Channel and Frequency List				
BW [MHz]	Channel/Frequency(MHz)	Lowest	Middle	Highest
15	Channel	141300	141500	141700
	Frequency	706.5	707.5	708.5
10	Channel	140800	141500	142200
	Frequency	704	707.5	711
5	Channel	140300	141500	142700
	Frequency	701.5	707.5	713.5

5G NR n66 Channel and Frequency List				
BW [MHz]	Channel/Frequency(MHz)	Lowest	Middle	Highest
45	Channel	346500	349000	351500
	Frequency	1732.5	1745	1757.5
40	Channel	346000	349000	352000
	Frequency	1730	1745	1760
35	Channel	345500	349000	352500
	Frequency	1727.5	1745	1762.5
30	Channel	345000	349000	353000
	Frequency	1725	1745	1765
25	Channel	344500	349000	353500
	Frequency	1722.5	1745	1767.5



20	Channel	344000	349000	354000
	Frequency	1720	1745	1770
15	Channel	343500	349000	354500
	Frequency	1717.5	1745	1772.5
10	Channel	343000	349000	355000
	Frequency	1715	1745	1775
5	Channel	342500	349000	355500
	Frequency	1712.5	1745	1777.5

5G NR n70 Channel and Frequency List				
BW [MHz]	Channel/Frequency(MHz)	Lowest	Middle	Highest
15	Channel	340500		
	Frequency	1702.5		
10	Channel	340000	340500	341000
	Frequency	1700	1702.5	1705
5	Channel	399500	340500	341500
	Frequency	1697.5	1702.5	1707.5

5G NR n71 Channel and Frequency List				
BW [MHz]	Channel/Frequency(MHz)	Lowest	Middle	Highest
35	Channel	136100		
	Frequency	680.5		
30	Channel	135600	136100	136600
	Frequency	678	680.5	683
25	Channel	135100	136100	137100
	Frequency	675.5	680.5	685.5
20	Channel	134600	136100	137600
	Frequency	673	680.5	688
15	Channel	134100	136100	138100
	Frequency	670.5	680.5	690.5
10	Channel	133600	136100	138600
	Frequency	668	680.5	693
5	Channel	133100	136100	139100
	Frequency	665.5	680.5	695.5

3 Conducted Test Items

3.1 Measuring Instruments

See list of measuring instruments of this test report.

3.2 Test Setup

3.2.1 Conducted Output Power

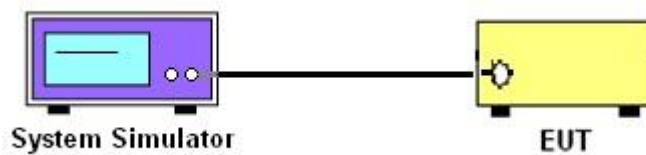

3.2.2 Peak-to-Average Ratio, Occupied Bandwidth ,Conducted Band-Edge and Conducted Spurious Emission

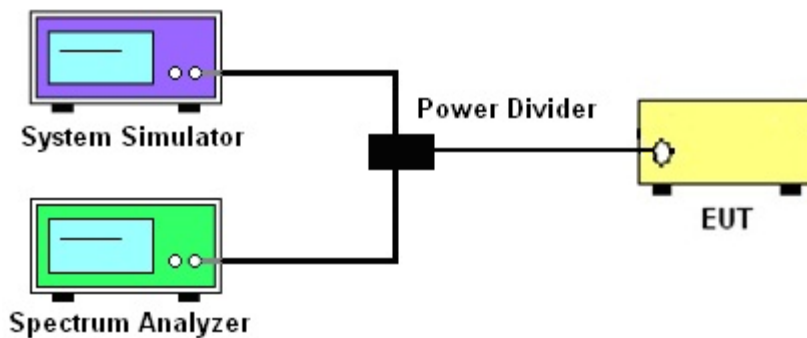

3.2.3 Frequency Stability

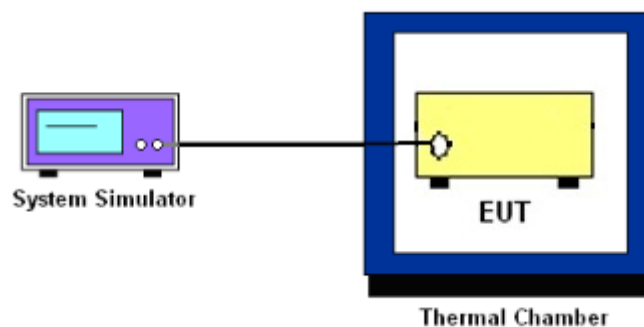

3.3 Test Result of Conducted Test

Please refer to Appendix A.



3.4 Conducted Output Power and ERP/EIRP

3.4.1 Description of the Conducted Output Power Measurement and ERP/EIRP Measurement

A system simulator was used to establish communication with the EUT. Its parameters were set to force the EUT transmitting at maximum output power. The measured power in the radio frequency on the transmitter output terminals shall be reported.

The ERP of mobile transmitters must not exceed 3 Watts for 5G NR n12, n71.

The EIRP of mobile transmitters must not exceed 1 Watts for 5G NR n66.

According to KDB 412172 D01 Power Approach,

$EIRP = P_T + G_T - L_C$, $ERP = EIRP - 2.15$, where

P_T = transmitter output power in dBm

G_T = gain of the transmitting antenna in dBi

L_C = signal attenuation in the connecting cable between the transmitter and antenna in dB

3.4.2 Test Procedures

1. The testing follows ANSI C63.26 Section 5.2
2. The transmitter output port was connected to the system simulator.
3. Set EUT at maximum power through the system simulator.
4. Select lowest, middle, and highest channels for each band and different modulation.
5. Measure and record the power level from the system simulator.



3.5 Peak-to-Average Ratio

3.5.1 Description of the PAR Measurement

Power Complementary Cumulative Distribution Function (CCDF) curves provide a means for characterizing the power peaks of a digitally modulated signal on a statistical basis. A CCDF curve depicts the probability of the peak signal amplitude exceeding the average power level. Most contemporary measurement instrumentation include the capability to produce CCDF curves for an input signal provided that the instrument's resolution bandwidth can be set wide enough to accommodate the entire input signal bandwidth. In measuring transmissions in this band using an average power technique, the peak-to-average ratio (PAR) of the transmission may not exceed 13 dB.

3.5.2 Test Procedures

1. The testing follows ANSI C63.26 Section 5.2.3.4 (CCDF).
2. The EUT was connected to spectrum and system simulator via a power divider.
3. Set the CCDF (Complementary Cumulative Distribution Function) option in spectrum analyzer.
4. The highest RF powers were measured and recorded the maximum PAPR level associated with a probability of 0.1 %.
5. Record the deviation as Peak to Average Ratio.



3.6 Occupied Bandwidth

3.6.1 Description of Occupied Bandwidth Measurement

The occupied bandwidth is the width of a frequency band such that, below the lower and above the upper frequency limits, the mean powers emitted are each equal to a specified percentage 0.5% of the total mean transmitted power.

The 26 dB emission bandwidth is defined as the frequency range between two points, one above and one below the carrier frequency, at which the spectral density of the emission is attenuated 26 dB below the maximum in-band spectral density of the modulated signal. Spectral density (power per unit bandwidth) is to be measured with a detector of resolution bandwidth equal to approximately 1.0% of the emission bandwidth.

3.6.2 Test Procedures

1. The testing follows ANSI C63.26 Section 5.4
2. The EUT was connected to spectrum analyzer and system simulator via a power divider.
3. The spectrum analyzer center frequency is set to the nominal EUT channel center frequency. The span range for the spectrum analyzer shall be between two and five times the anticipated OBW.
4. The nominal resolution bandwidth (RBW) shall be in the range of 1 to 5 % of the anticipated OBW, and the VBW shall be at least 3 times the RBW.
5. Set the detection mode to peak, and the trace mode to max hold.
6. Determine the reference value: Set the EUT to transmit a modulated signal. Allow the trace to stabilize. Set the spectrum analyzer marker to the highest level of the displayed trace.
(this is the reference value)
7. Determine the “-26 dB down amplitude” as equal to (Reference Value – X).
8. Place two markers, one at the lowest and the other at the highest frequency of the envelope of the spectral display such that each marker is at or slightly below the “-X dB down amplitude” determined in step 6. If a marker is below this “-X dB down amplitude” value it shall be placed as close as possible to this value. The OBW is the positive frequency difference between the two markers.
9. Use the 99 % power bandwidth function of the spectrum analyzer and report the measured bandwidth.



3.7 Conducted Band Edge

3.7.1 Description of Conducted Band Edge Measurement

27.53 (h)

For operations in the 1710 – 1755 MHz band, the FCC limit is $43 + 10\log_{10}(P[\text{Watts}])$ dB below the transmitter power $P(\text{Watts})$ in a 1 MHz bandwidth. However, in the 1MHz bands immediately outside and adjacent to the licensee's frequency block, a resolution bandwidth of at least one percent of the emission bandwidth of the fundamental emission of the transmitter may be employed.

27.53 (g)

For operations in the 600MHz band and 698 -746 MHz band, the FCC limit is $43 + 10\log_{10}(P[\text{Watts}])$ dB below the transmitter power $P(\text{Watts})$ in a 100 kHz bandwidth. However, in the 100 kilohertz bands immediately outside and adjacent to a licensee's frequency block, a resolution bandwidth of at least 30 kHz may be employed.

3.7.2 Test Procedures

1. The testing follows ANSI C63.26 section 5.7
2. The EUT was connected to spectrum analyzer and system simulator via a power divider.
3. The band edges of low and high channels for the highest RF powers were measured.
4. Set RBW \geq 1% EBW in the 1MHz band immediately outside and adjacent to the band edge.
5. Beyond the 1 MHz band from the band edge, RBW=1MHz was used or a narrower RBW was used (generally limited to no less than 1% of the OBW) and the measured power was integrated over the full required measurement bandwidth.
6. Set spectrum analyzer with RMS detector.
7. The RF fundamental frequency should be excluded against the limit line in the operating frequency band.
8. Checked that all the results comply with the emission limit line.

Example:

$$\begin{aligned} &\text{The limit line is derived from } 43 + 10\log(P)\text{dB below the transmitter power } P(\text{Watts}) \\ &= P(\text{W}) - [43 + 10\log(P)] \text{ (dB)} \\ &= [30 + 10\log(P)] \text{ (dBm)} - [43 + 10\log(P)] \text{ (dB)} = -13\text{dBm}. \end{aligned}$$

9. When using the integration method, the starting frequency of the integration shall be centered at one-half of the RBW away from the band edge.



3.8 Conducted Spurious Emission

3.8.1 Description of Conducted Spurious Emission Measurement

The power of any emission outside of the authorized operating frequency ranges must be lower than the transmitter power (P) by a factor of at least $43 + 10 \log (P)$ dB.

It is measured by means of a calibrated spectrum analyzer and scanned from 30 MHz up to a frequency including its 10th harmonic.

3.8.2 Test Procedures

1. The testing follows ANSI C63.26 section 5.7
2. The EUT was connected to spectrum analyzer and system simulator via a power divider.
3. The RF output of EUT was connected to the spectrum analyzer by RF cable and attenuator. The path loss was compensated to the results for each measurement.
4. The middle channel for the highest RF power within the transmitting frequency was measured.
5. The conducted spurious emission for the whole frequency range was taken.
6. Make the measurement with the spectrum analyzer's RBW = 1MHz, VBW = 3MHz.
7. Set spectrum analyzer with RMS detector.
8. Taking the record of maximum spurious emission.
9. The RF fundamental frequency should be excluded against the limit line in the operating frequency band.
10. The limit line is derived from $43 + 10\log(P)$ dB below the transmitter power P(Watts)
= P(W)- [43 + 10log(P)] (dB)
= [30 + 10log(P)] (dBm) - [43 + 10log(P)] (dB)
= -13dBm.



3.9 Frequency Stability

3.9.1 Description of Frequency Stability Measurement

The frequency stability shall be measured by variation of ambient temperature and variation of primary supply voltage to ensure that the fundamental emission stays within the authorized frequency block. The frequency stability of the transmitter shall be maintained within $\pm 0.00025\%$ ($\pm 2.5\text{ppm}$) of the center frequency.

3.9.2 Test Procedures for Temperature Variation

1. The testing follows ANSI C63.26 section 5.6.4
2. The EUT was set up in the thermal chamber and connected with the system simulator.
3. With power OFF, the temperature was decreased to -30°C and the EUT was stabilized before testing. Power was applied and the maximum change in frequency was recorded within one minute.
4. With power OFF, the temperature was raised in 10°C step up to 50°C . The EUT was stabilized at each step for at least half an hour. Power was applied and the maximum frequency change was recorded within one minute.

3.9.3 Test Procedures for Voltage Variation

1. The testing follows ANSI C63.26 section 5.6.5
2. The EUT was placed in a temperature chamber at $20\pm 5^{\circ}\text{C}$ and connected with the system simulator.
3. The power supply voltage to the EUT was varied from 85% to 115% of the nominal value for other than hand carried battery equipment.
4. For hand carried, battery powered equipment, reduce the primary ac or dc supply voltage to the battery operating end point, which shall be specified by the manufacturer.
5. The variation in frequency was measured for the worst case.

4 Radiated Test Items

4.1 Measuring Instruments

See list of measuring instruments of this test report.

4.2 Test Setup

4.2.1 For radiated test below 30MHz

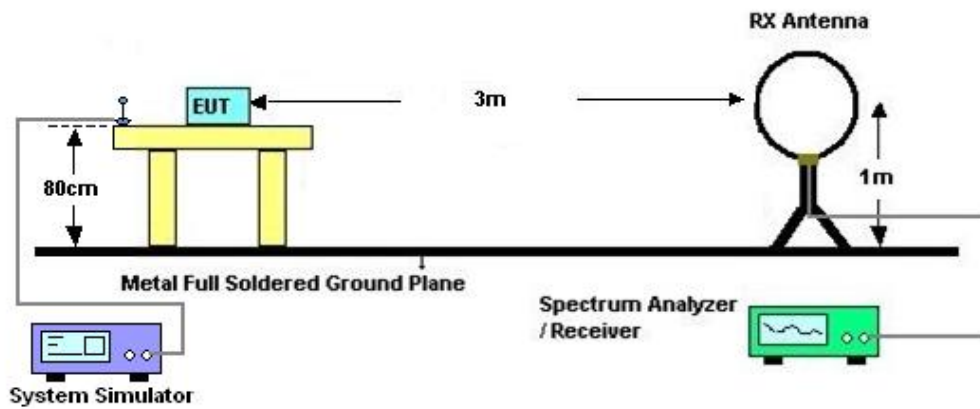

4.2.2 For radiated test from 30MHz to 1GHz

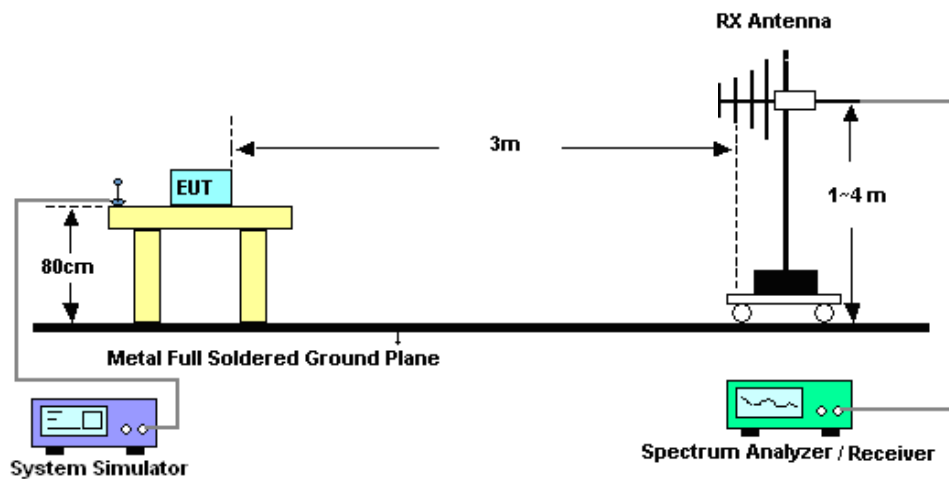

4.2.3 For radiated test above 1GHz

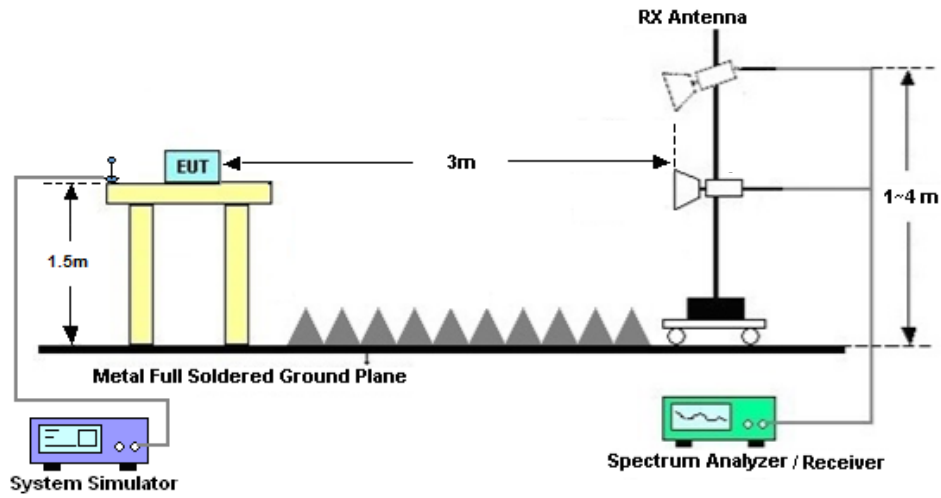

4.3 Test Result of Radiated Test

The low frequency, which started from 9 kHz to 30MHz, was pre-scanned and the result which was 20dB lower than the limit line was not reported.

Please refer to Appendix B.



4.4 Radiated Spurious Emission

4.4.1 Description of Radiated Spurious Emission

The radiated spurious emission was measured by substitution method according to ANSI C63.26. The power of any emission outside of the authorized operating frequency ranges must be attenuated below the transmitter power (P) by a factor of at least $43 + 10 \log (P)$ dB.

The spectrum is scanned from 30 MHz up to a frequency including its 10th harmonic.

4.4.2 Test Procedures

1. The testing follows ANSI C63.26 Section 5.5
2. The EUT was placed on a turntable with 0.8 meter height for frequency below 1GHz and 1.5 meter height for frequency above 1GHz respectively above ground.
3. The EUT was set 3 meters from the receiving antenna mounted on the antenna tower.
4. The table was rotated 360 degrees to determine the position of the highest spurious emission.
5. The height of the receiving antenna is varied between 1m to 4m to search the maximum spurious emission for both horizontal and vertical polarizations.
6. During the measurement, the system simulator parameters were set to force the EUT transmitting at maximum output power.
7. Make the measurement with the spectrum analyzer's RBW = 1MHz, VBW = 3MHz, taking the record of maximum spurious emission.
8. A horn antenna was substituted in place of the EUT and was driven by a signal generator.
9. Tune the output power of signal generator to the same emission level with EUT maximum spurious emission.
10. $EIRP (dBm) = S.G. Power - Tx Cable Loss + Tx Antenna Gain$
11. $ERP (dBm) = EIRP - 2.15$
12. The RF fundamental frequency should be excluded against the limit line in the operating frequency band.

The limit line is derived from $43 + 10\log(P)$ dB below the transmitter power P(Watts)
 $= P(W) - [43 + 10\log(P)] (dB)$
 $= [30 + 10\log(P)] (dBm) - [43 + 10\log(P)] (dB)$
 $= -13dBm.$



5 List of Measuring Equipment

Instrument	Manufacturer	Model No.	Serial No.	Characteristics	Calibration Date	Test Date	Due Date	Remark
Spectrum Analyzer	R&S	FSV40	101040	10Hz~40GHz	Oct. 10, 2024	Jan. 20, 2025~ Feb. 17, 2025	Oct. 09, 2025	Conducted (TH01-KS)
Power divider	STI	STI08-0055	-	0.5~40GHz	NCR	Jan. 20, 2025~ Feb. 17, 2025	NCR	Conducted (TH01-KS)
Temperature & humidity chamber	Hongzhan	LP-150U	H2014011440	-40~+150°C 20%~95%RH	Jul. 04, 2024	Jan. 20, 2025~ Feb. 17, 2025	Jul. 03, 2025	Conducted (TH01-KS)
EMI Test Receiver&SA	KEYSIGHT	N9038A	MY54450083	20Hz~8.4GHz	Apr. 09, 2024	Feb. 14, 2025~ Feb. 15, 2025	Apr. 08, 2025	Radiation (03CH03-SZ)
Loop Antenna	R&S	HFH2-Z2E	101141	9kHz~30MHz	Dec. 28, 2024	Feb. 14, 2025~ Feb. 15, 2025	Dec. 27, 2025	Radiation (03CH03-SZ)
EXA Spectrum Analyzer	KEYSIGHT	N9010A	MY55150246	10Hz~44GHz;	Apr. 09, 2024	Feb. 14, 2025~ Feb. 15, 2025	Apr. 08, 2025	Radiation (03CH03-SZ)
Bilog Antenna	TeseQ	CBL6112D	35408	30MHz-2GHz	Aug. 20, 2023	Feb. 14, 2025~ Feb. 15, 2025	Aug. 19, 2025	Radiation (03CH03-SZ)
Double Ridge Horn Antenna	SCHWARZBECK	BBHA9120D	9120D-1355	1GHz~18GHz	Apr. 09, 2024	Feb. 14, 2025~ Feb. 15, 2025	Apr. 08, 2025	Radiation (03CH03-SZ)
LF Amplifier	Burgeon	BPA-530	102209	0.01~3000Mhz	Apr. 09, 2024	Feb. 14, 2025~ Feb. 15, 2025	Apr. 08, 2025	Radiation (03CH03-SZ)
HF Amplifier	MITEQ	TTA1840-35-HG	1871923	18GHz~40GHz	Jul. 03, 2024	Feb. 14, 2025~ Feb. 15, 2025	Jul. 02, 2025	Radiation (03CH03-SZ)
SHF-EHF Horn	com-power	AH-840	101071	18Ghz-40GHz	Apr. 09, 2024	Feb. 14, 2025~ Feb. 15, 2025	Apr. 08, 2025	Radiation (03CH03-SZ)
AC Power Source	Chroma	61601	616010002729	N/A	Oct. 18, 2024	Feb. 14, 2025~ Feb. 15, 2025	Oct. 17, 2025	Radiation (03CH03-SZ)
Turn Table	EM	EM1000	N/A	0~360 degree	NCR	Feb. 14, 2025~ Feb. 15, 2025	NCR	Radiation (03CH03-SZ)
Antenna Mast	EM	EM1000	N/A	1 m~4 m	NCR	Feb. 14, 2025~ Feb. 15, 2025	NCR	Radiation (03CH03-SZ)

NCR: No Calibration Required



6 Measurement Uncertainty

The measurement uncertainties shown below were calculated in accordance with the requirements of ANSI 63.26-2015. All the measurement uncertainty value were shown with a coverage K=2 to indicate 95% level of confidence. The measurement data show herein meets or exceeds the CISPR measurement uncertainty values specified in CISPR 16-4-2 and can be compared directly to specified limit to determine compliance.

Uncertainty of Conducted Measurement

Test Item	Uncertainty
Conducted Spurious Emission & Bandedge	±2.22 dB
Occupied Channel Bandwidth	±0.1%
Conducted Power	±0.50 dB
Peak to Average Ratio	±0.90 dB
Frequency Stability	±0.04ppm

Uncertainty of Radiated Emission Measurement (30 MHz ~ 1000 MHz)

Measuring Uncertainty for a Level of Confidence of 95% (U = 2Uc(y))	3.0 dB
---	--------

Uncertainty of Radiated Emission Measurement (1 GHz ~ 18 GHz)

Measuring Uncertainty for a Level of Confidence of 95% (U = 2Uc(y))	3.6 dB
---	--------

Uncertainty of Radiated Emission Measurement (18 GHz ~ 40 GHz)

Measuring Uncertainty for a Level of Confidence of 95% (U = 2Uc(y))	3.8 dB
---	--------

----- THE END -----



Appendix A. Test Results of Conducted Test

Test Engineer :	Khan Zhen	Temperature :	22~23°C
		Relative Humidity :	40~42%



Software Version: 23.06.1602

FR1 N12 ANT0

Transmitter Conducted Output Power And ERP, (G_T - L_c)=-5.2dB

NR Band	SCS	Bandwidth	Arfcn	Freq(M Hz)	Modulation	RB	Conducted Power(dBm)	ERP(dBm)	ERP(W)
12	15	5	140300	701.5	DFT-s-OFDM QPSK	12@6	23.11	15.76	0.0377
12	15	5	140300	701.5	DFT-s-OFDM QPSK	1@1	22.97	15.62	0.0365
12	15	5	140300	701.5	DFT-s-OFDM QPSK	1@23	22.89	15.54	0.0358
12	15	5	140300	701.5	DFT-s-OFDM 16 QAM	12@6	21.94	14.59	0.0288
12	15	5	140300	701.5	DFT-s-OFDM 16 QAM	1@1	21.99	14.64	0.0291
12	15	5	140300	701.5	DFT-s-OFDM 16 QAM	1@23	22.04	14.69	0.0294
12	15	5	141500	707.5	DFT-s-OFDM QPSK	12@6	23.16	15.81	0.0381
12	15	5	141500	707.5	DFT-s-OFDM QPSK	1@1	23.19	15.84	0.0384
12	15	5	141500	707.5	DFT-s-OFDM QPSK	1@23	22.96	15.61	0.0364
12	15	5	141500	707.5	DFT-s-OFDM 16 QAM	12@6	21.95	14.6	0.0288
12	15	5	141500	707.5	DFT-s-OFDM 16 QAM	1@1	22.14	14.79	0.0301
12	15	5	141500	707.5	DFT-s-OFDM 16 QAM	1@23	22.15	14.8	0.0302
12	15	5	142700	713.5	DFT-s-OFDM QPSK	12@6	23.21	15.86	0.0385
12	15	5	142700	713.5	DFT-s-OFDM QPSK	1@1	23.14	15.79	0.0379
12	15	5	142700	713.5	DFT-s-OFDM QPSK	1@23	22.82	15.47	0.0352
12	15	5	142700	713.5	DFT-s-OFDM 16 QAM	12@6	22.02	14.67	0.0293
12	15	5	142700	713.5	DFT-s-OFDM 16 QAM	1@1	22.16	14.81	0.0303
12	15	5	142700	713.5	DFT-s-OFDM 16 QAM	1@23	22.03	14.68	0.0294
12	15	10	140800	704	DFT-s-OFDM QPSK	25@12	23.03	15.68	0.0370
12	15	10	140800	704	DFT-s-OFDM QPSK	1@1	22.9	15.55	0.0359
12	15	10	140800	704	DFT-s-OFDM QPSK	1@50	22.88	15.53	0.0357
12	15	10	140800	704	DFT-s-OFDM 16 QAM	25@12	21.96	14.61	0.0289
12	15	10	140800	704	DFT-s-OFDM 16 QAM	1@1	22.05	14.7	0.0295
12	15	10	140800	704	DFT-s-OFDM 16 QAM	1@50	22.11	14.76	0.0299
12	15	10	141500	707.5	DFT-s-OFDM QPSK	25@12	23.09	15.74	0.0375
12	15	10	141500	707.5	DFT-s-OFDM QPSK	1@1	23.26	15.91	0.0390
12	15	10	141500	707.5	DFT-s-OFDM QPSK	1@50	22.86	15.51	0.0356
12	15	10	141500	707.5	DFT-s-OFDM 16 QAM	25@12	21.98	14.63	0.0290
12	15	10	141500	707.5	DFT-s-OFDM 16 QAM	1@1	22.23	14.88	0.0308
12	15	10	141500	707.5	DFT-s-OFDM 16 QAM	1@50	22.16	14.81	0.0303
12	15	10	142200	711	DFT-s-OFDM QPSK	25@12	23.14	15.79	0.0379
12	15	10	142200	711	DFT-s-OFDM QPSK	1@1	23.1	15.75	0.0376
12	15	10	142200	711	DFT-s-OFDM QPSK	1@50	22.87	15.52	0.0356
12	15	10	142200	711	DFT-s-OFDM 16 QAM	25@12	21.89	14.54	0.0284



12	15	10	142200	711	DFT-s-OFDM 16 QAM	1@1	22.11	14.76	0.0299
12	15	10	142200	711	DFT-s-OFDM 16 QAM	1@50	22.12	14.77	0.0300
12	15	15	141300	706.5	DFT-s-OFDM PI/2 BPSK	36@18	23.27	15.92	0.0391
12	15	15	141300	706.5	DFT-s-OFDM PI/2 BPSK	1@1	22.99	15.64	0.0366
12	15	15	141300	706.5	DFT-s-OFDM PI/2 BPSK	1@77	22.9	15.55	0.0359
12	15	15	141300	706.5	DFT-s-OFDM QPSK	36@18	23	15.65	0.0367
12	15	15	141300	706.5	DFT-s-OFDM QPSK	1@1	22.89	15.54	0.0358
12	15	15	141300	706.5	DFT-s-OFDM QPSK	1@77	22.86	15.51	0.0356
12	15	15	141300	706.5	DFT-s-OFDM 16 QAM	36@18	22.01	14.66	0.0292
12	15	15	141300	706.5	DFT-s-OFDM 16 QAM	1@1	22.17	14.82	0.0303
12	15	15	141300	706.5	DFT-s-OFDM 16 QAM	1@77	22.04	14.69	0.0294
12	15	15	141300	706.5	DFT-s-OFDM 64 QAM	36@18	20.58	13.23	0.0210
12	15	15	141300	706.5	DFT-s-OFDM 64 QAM	1@1	20.29	12.94	0.0197
12	15	15	141300	706.5	DFT-s-OFDM 64 QAM	1@77	20.27	12.92	0.0196
12	15	15	141300	706.5	DFT-s-OFDM 256 QAM	36@18	18.55	11.2	0.0132
12	15	15	141300	706.5	DFT-s-OFDM 256 QAM	1@1	18.41	11.06	0.0128
12	15	15	141300	706.5	DFT-s-OFDM 256 QAM	1@77	18.43	11.08	0.0128
12	15	15	141300	706.5	CP-OFDM QPSK	39@19	21.58	14.23	0.0265
12	15	15	141300	706.5	CP-OFDM QPSK	1@1	21.62	14.27	0.0267
12	15	15	141300	706.5	CP-OFDM QPSK	1@77	21.56	14.21	0.0264
12	15	15	141500	707.5	DFT-s-OFDM PI/2 BPSK	36@18	23.09	15.74	0.0375
12	15	15	141500	707.5	DFT-s-OFDM PI/2 BPSK	1@1	22.97	15.62	0.0365
12	15	15	141500	707.5	DFT-s-OFDM PI/2 BPSK	1@77	22.87	15.52	0.0356
12	15	15	141500	707.5	DFT-s-OFDM QPSK	36@18	22.97	15.62	0.0365
12	15	15	141500	707.5	DFT-s-OFDM QPSK	1@1	22.97	15.62	0.0365
12	15	15	141500	707.5	DFT-s-OFDM QPSK	1@77	22.7	15.35	0.0343
12	15	15	141500	707.5	DFT-s-OFDM 16 QAM	36@18	22.01	14.66	0.0292
12	15	15	141500	707.5	DFT-s-OFDM 16 QAM	1@1	22.11	14.76	0.0299
12	15	15	141500	707.5	DFT-s-OFDM 16 QAM	1@77	22.1	14.75	0.0299
12	15	15	141500	707.5	DFT-s-OFDM 64 QAM	36@18	20.55	13.2	0.0209
12	15	15	141500	707.5	DFT-s-OFDM 64 QAM	1@1	20.33	12.98	0.0199
12	15	15	141500	707.5	DFT-s-OFDM 64 QAM	1@77	20.19	12.84	0.0192
12	15	15	141500	707.5	DFT-s-OFDM 256 QAM	36@18	18.63	11.28	0.0134
12	15	15	141500	707.5	DFT-s-OFDM 256 QAM	1@1	18.42	11.07	0.0128
12	15	15	141500	707.5	DFT-s-OFDM 256 QAM	1@77	18.31	10.96	0.0125
12	15	15	141500	707.5	CP-OFDM QPSK	39@19	21.54	14.19	0.0262
12	15	15	141500	707.5	CP-OFDM QPSK	1@1	21.5	14.15	0.0260
12	15	15	141500	707.5	CP-OFDM QPSK	1@77	21.65	14.3	0.0269



12	15	15	141700	708.5	DFT-s-OFDM PI/2 BPSK	36@18	23.18	15.83	0.0383
12	15	15	141700	708.5	DFT-s-OFDM PI/2 BPSK	1@1	22.94	15.59	0.0362
12	15	15	141700	708.5	DFT-s-OFDM PI/2 BPSK	1@77	22.81	15.46	0.0352
12	15	15	141700	708.5	DFT-s-OFDM QPSK	36@18	22.92	15.57	0.0361
12	15	15	141700	708.5	DFT-s-OFDM QPSK	1@1	23.17	15.82	0.0382
12	15	15	141700	708.5	DFT-s-OFDM QPSK	1@77	22.71	15.36	0.0344
12	15	15	141700	708.5	DFT-s-OFDM 16 QAM	36@18	22.02	14.67	0.0293
12	15	15	141700	708.5	DFT-s-OFDM 16 QAM	1@1	22.06	14.71	0.0296
12	15	15	141700	708.5	DFT-s-OFDM 16 QAM	1@77	22.01	14.66	0.0292
12	15	15	141700	708.5	DFT-s-OFDM 64 QAM	36@18	20.5	13.15	0.0207
12	15	15	141700	708.5	DFT-s-OFDM 64 QAM	1@1	20.26	12.91	0.0195
12	15	15	141700	708.5	DFT-s-OFDM 64 QAM	1@77	20.11	12.76	0.0189
12	15	15	141700	708.5	DFT-s-OFDM 256 QAM	36@18	18.56	11.21	0.0132
12	15	15	141700	708.5	DFT-s-OFDM 256 QAM	1@1	18.31	10.96	0.0125
12	15	15	141700	708.5	DFT-s-OFDM 256 QAM	1@77	18.35	11	0.0126
12	15	15	141700	708.5	CP-OFDM QPSK	39@19	21.49	14.14	0.0259
12	15	15	141700	708.5	CP-OFDM QPSK	1@1	21.4	14.05	0.0254
12	15	15	141700	708.5	CP-OFDM QPSK	1@77	21.48	14.13	0.0259



Frequency Stability

NR Band	SCS (kHz)	Bandwidth (MHz)	Arfcn	Freq (MHz)	Modulation	RB	Deviation (Hz)	Verdict	Environment
12	15	10	141500	707.5	DFT-s-OFDM QPSK	50@0	12.9	PASS	NV
12	15	10	141500	707.5	DFT-s-OFDM QPSK	50@0	17.7	PASS	LV
12	15	10	141500	707.5	DFT-s-OFDM QPSK	50@0	11.8	PASS	HV
12	15	10	141500	707.5	DFT-s-OFDM QPSK	50@0	16.3	PASS	-30°C
12	15	10	141500	707.5	DFT-s-OFDM QPSK	50@0	12.3	PASS	-20°C
12	15	10	141500	707.5	DFT-s-OFDM QPSK	50@0	13.5	PASS	-10°C
12	15	10	141500	707.5	DFT-s-OFDM QPSK	50@0	13.6	PASS	0°C
12	15	10	141500	707.5	DFT-s-OFDM QPSK	50@0	15.6	PASS	10°C
12	15	10	141500	707.5	DFT-s-OFDM QPSK	50@0	17.0	PASS	20°C
12	15	10	141500	707.5	DFT-s-OFDM QPSK	50@0	19.4	PASS	30°C
12	15	10	141500	707.5	DFT-s-OFDM QPSK	50@0	16.4	PASS	40°C
12	15	10	141500	707.5	DFT-s-OFDM QPSK	50@0	19.1	PASS	50°C

|MAX(Δf)| = 19.4 Hz

Frequency Stability	Frequency (MHz)	Limit Line	Result
$f_L - \text{MAX}(\Delta f) $	699.4270806	$\geq 699 \text{ MHz}$	PASS
$f_H + \text{MAX}(\Delta f) $	714.8237194	$\leq 716 \text{ MHz}$	



Peak to Average Ratio

NR Band	SCS (kHz)	Bandwidth (MHz)	Arfcn	Freq (MHz)	Modulation	RB	Result (dB)	Limit (dB)	Verdict
12	15	10	141500	707.5	DFT-s-OFDM PI/2 BPSK	50@0	4.21	13	PASS
12	15	10	141500	707.5	DFT-s-OFDM QPSK	50@0	5.3	13	PASS

N12(10M)_DFT-s-OFDM_PI_2-BPSK_Outer_Full_Mid_CH



N12(10M)_DFT-s-OFDM_QPSK_Outer_Full_Mid_CH





Occupied Bandwidth

NR Band	SCS (kHz)	Bandwidth (MHz)	Arfcn	Freq (MHz)	Modulation	RB	OBW (MHz)	26dB BW (MHz)
12	15	5	141500	707.5	CP-OFDM QPSK	25@0	4.4612	4.812
12	15	5	141500	707.5	CP-OFDM 16 QAM	25@0	4.4628	4.752
12	15	5	141500	707.5	CP-OFDM 64 QAM	25@0	4.4755	4.803
12	15	5	141500	707.5	CP-OFDM 256 QAM	25@0	4.4728	4.783
12	15	10	141500	707.5	CP-OFDM QPSK	52@0	9.2698	9.705
12	15	10	141500	707.5	CP-OFDM 16 QAM	52@0	9.263	9.694
12	15	10	141500	707.5	CP-OFDM 64 QAM	52@0	9.2902	9.736
12	15	10	141500	707.5	CP-OFDM 256 QAM	52@0	9.2684	9.649
12	15	15	141500	707.5	CP-OFDM QPSK	79@0	14.046	14.71
12	15	15	141500	707.5	CP-OFDM 16 QAM	79@0	14.073	14.67
12	15	15	141500	707.5	CP-OFDM 64 QAM	79@0	14.097	14.65
12	15	15	141500	707.5	CP-OFDM 256 QAM	79@0	14.106	14.7



N12(5M)_CP-OFDM_QPSK_Outer_Full_Mid_CH

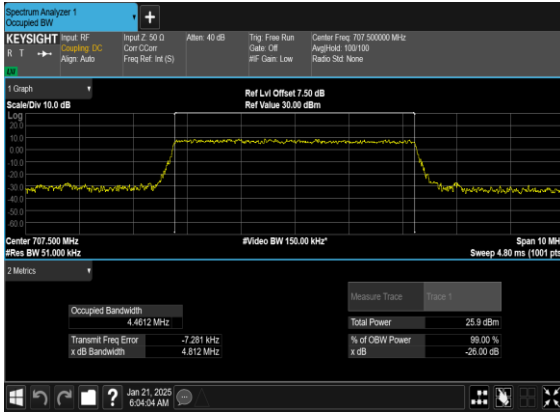

N12(5M)_CP-OFDM_16QAM_Outer_Full_Mid_CH

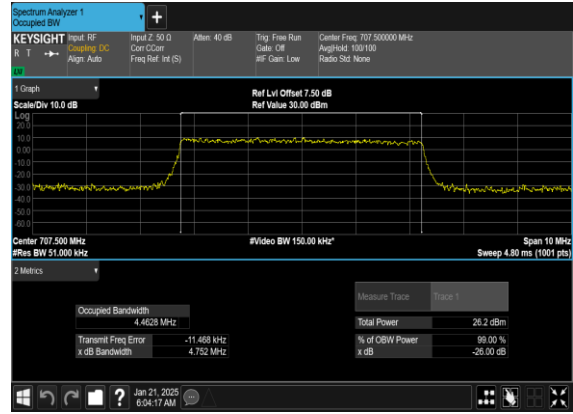

N12(5M)_CP-OFDM_64QAM_Outer_Full_Mid_CH

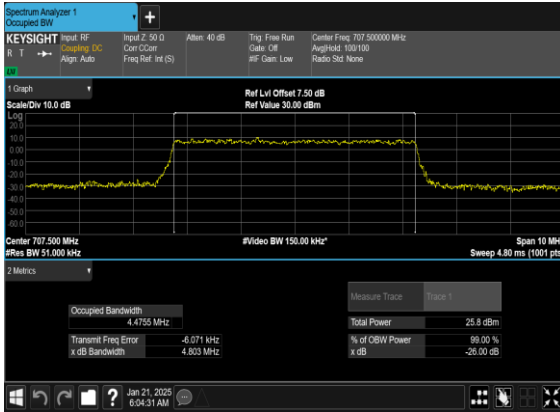

N12(5M)_CP-OFDM_256QAM_Outer_Full_Mid_CH





N12(10M)_CP-OFDM_QPSK_Outer_Full_Mid_CH

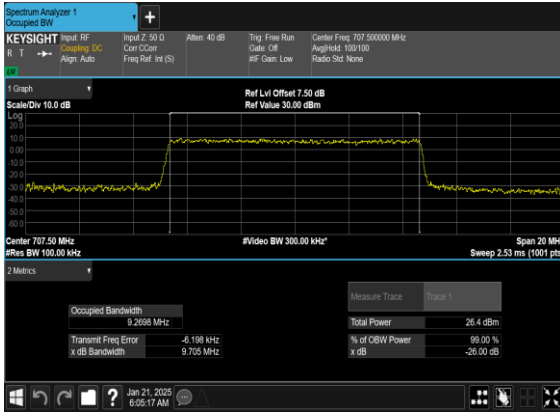

N12(10M)_CP-OFDM_16QAM_Outer_Full_Mid_CH

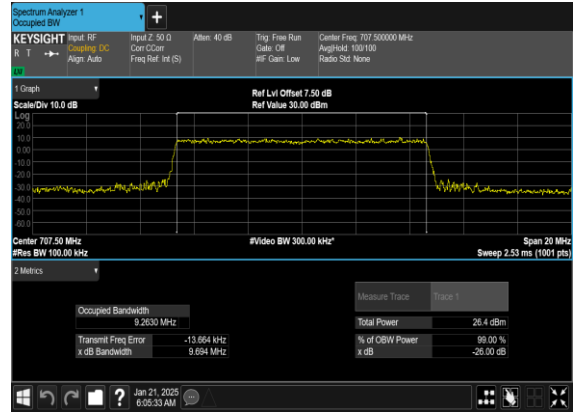

N12(10M)_CP-OFDM_64QAM_Outer_Full_Mid_CH



N12(10M)_CP-OFDM_256QAM_Outer_Full_Mid_CH





N12(15M)_CP-OFDM_QPSK_Outer_Full_Mid_CH

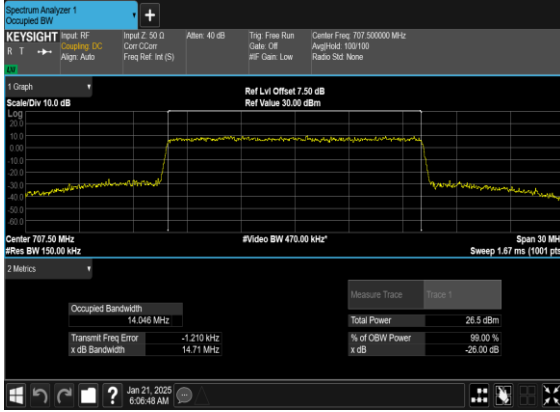

N12(15M)_CP-OFDM_16QAM_Outer_Full_Mid_CH

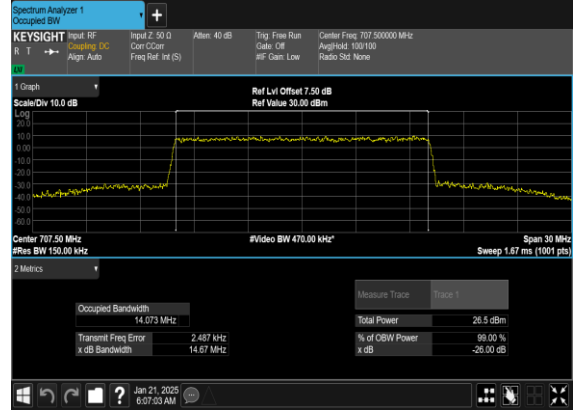

N12(15M)_CP-OFDM_64QAM_Outer_Full_Mid_CH

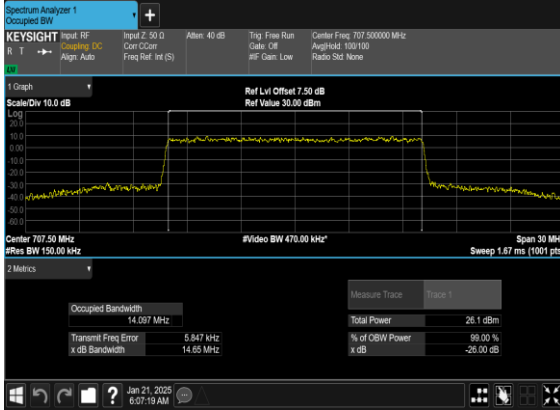

N12(15M)_CP-OFDM_256QAM_Outer_Full_Mid_CH

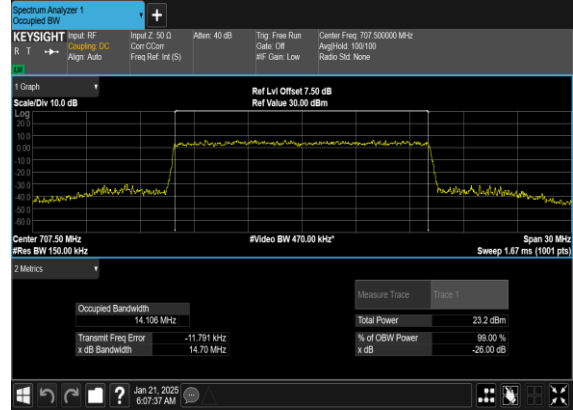



Conducted Spurious Emissions

NR Band	SCS (kHz)	Bandwidth (MHz)	Arfcn	Freq (MHz)	Modulation	RB	Result	Verdict
12	15	5	140300	701.5	DFT-s-OFDM BPSK	1@0	see graph	---
12	15	5	140300	701.5	DFT-s-OFDM BPSK	1@0	see graph	PASS
12	15	5	140300	701.5	DFT-s-OFDM QPSK	1@0	see graph	---
12	15	5	140300	701.5	DFT-s-OFDM QPSK	1@0	see graph	PASS
12	15	5	141500	707.5	DFT-s-OFDM BPSK	1@0	see graph	---
12	15	5	141500	707.5	DFT-s-OFDM BPSK	1@0	see graph	PASS
12	15	5	141500	707.5	DFT-s-OFDM QPSK	1@0	see graph	---
12	15	5	141500	707.5	DFT-s-OFDM QPSK	1@0	see graph	PASS
12	15	5	142700	713.5	DFT-s-OFDM BPSK	1@0	see graph	---
12	15	5	142700	713.5	DFT-s-OFDM BPSK	1@0	see graph	PASS
12	15	5	142700	713.5	DFT-s-OFDM QPSK	1@0	see graph	---
12	15	5	142700	713.5	DFT-s-OFDM QPSK	1@0	see graph	PASS
12	15	10	140800	704.0	DFT-s-OFDM BPSK	1@0	see graph	---
12	15	10	140800	704.0	DFT-s-OFDM BPSK	1@0	see graph	PASS
12	15	10	140800	704.0	DFT-s-OFDM QPSK	1@0	see graph	---
12	15	10	140800	704.0	DFT-s-OFDM QPSK	1@0	see graph	PASS
12	15	10	141500	707.5	DFT-s-OFDM BPSK	1@0	see graph	---
12	15	10	141500	707.5	DFT-s-OFDM BPSK	1@0	see graph	PASS
12	15	10	141500	707.5	DFT-s-OFDM QPSK	1@0	see graph	---
12	15	10	141500	707.5	DFT-s-OFDM QPSK	1@0	see graph	PASS



12	15	10	142200	711.0	DFT-s-OFDM BPSK	1@0	see graph	---
12	15	10	142200	711.0	DFT-s-OFDM BPSK	1@0	see graph	PASS
12	15	10	142200	711.0	DFT-s-OFDM QPSK	1@0	see graph	---
12	15	10	142200	711.0	DFT-s-OFDM QPSK	1@0	see graph	PASS
12	15	15	141300	706.5	DFT-s-OFDM BPSK	1@0	see graph	---
12	15	15	141300	706.5	DFT-s-OFDM BPSK	1@0	see graph	PASS
12	15	15	141300	706.5	DFT-s-OFDM QPSK	1@0	see graph	---
12	15	15	141300	706.5	DFT-s-OFDM QPSK	1@0	see graph	PASS
12	15	15	141500	707.5	DFT-s-OFDM BPSK	1@0	see graph	---
12	15	15	141500	707.5	DFT-s-OFDM BPSK	1@0	see graph	PASS
12	15	15	141500	707.5	DFT-s-OFDM QPSK	1@0	see graph	---
12	15	15	141500	707.5	DFT-s-OFDM QPSK	1@0	see graph	PASS
12	15	15	141700	708.5	DFT-s-OFDM BPSK	1@0	see graph	---
12	15	15	141700	708.5	DFT-s-OFDM BPSK	1@0	see graph	PASS
12	15	15	141700	708.5	DFT-s-OFDM QPSK	1@0	see graph	---
12	15	15	141700	708.5	DFT-s-OFDM QPSK	1@0	see graph	PASS



N12(5M)_DFT-s-OFDM_BPSK_Edge_1RB_Left_Low_CH

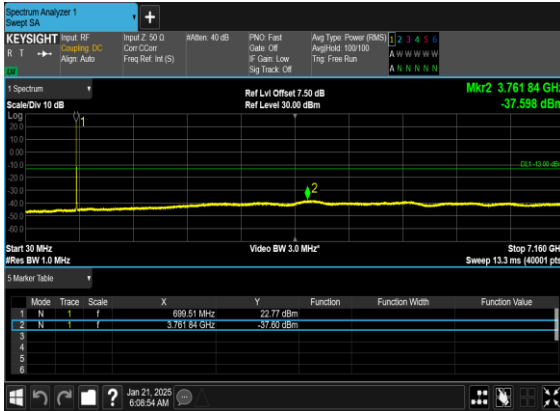

N12(5M)_DFT-s-OFDM_QPSK_Edge_1RB_Left_Low_CH



N12(5M)_DFT-s-OFDM_BPSK_Edge_1RB_Left_Mid_CH

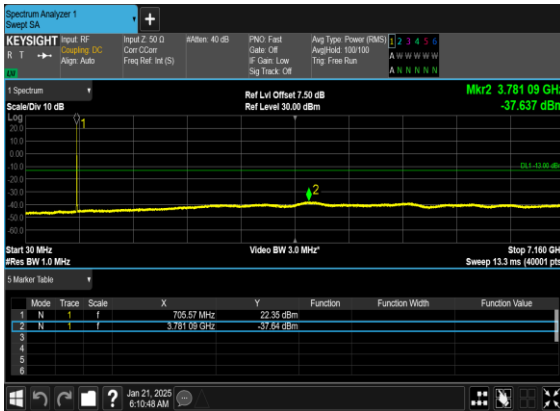

N12(5M)_DFT-s-OFDM_QPSK_Edge_1RB_Left_Mid_CH

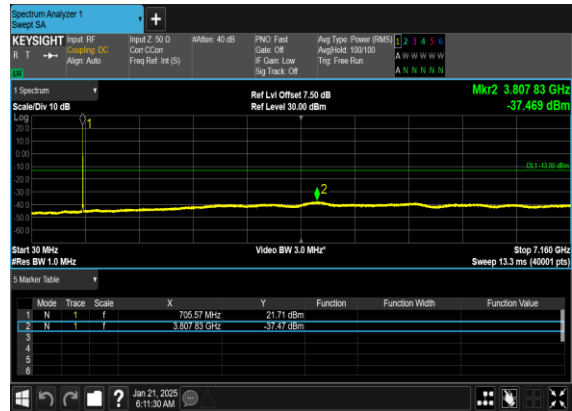



N12(5M)_DFT-s-OFDM_BPSK_Edge_1RB_Left_High_CH



N12(5M)_DFT-s-OFDM_QPSK_Edge_1RB_Left_High_CH

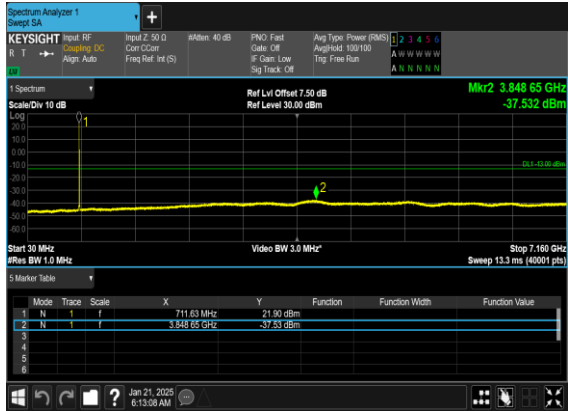

N12(10M)_DFT-s-OFDM_BPSK_Edge_1RB_Left_Low_CH

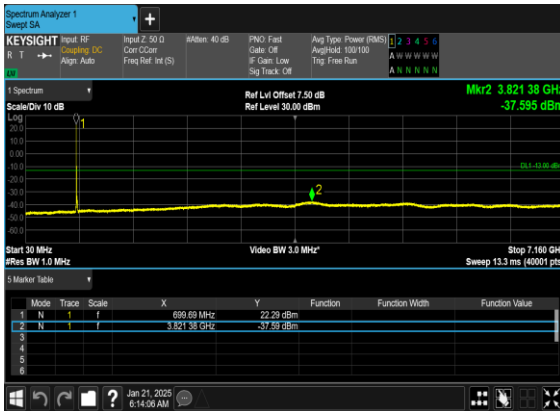

N12(10M)_DFT-s-OFDM_QPSK_Edge_1RB_Left_Low_CH

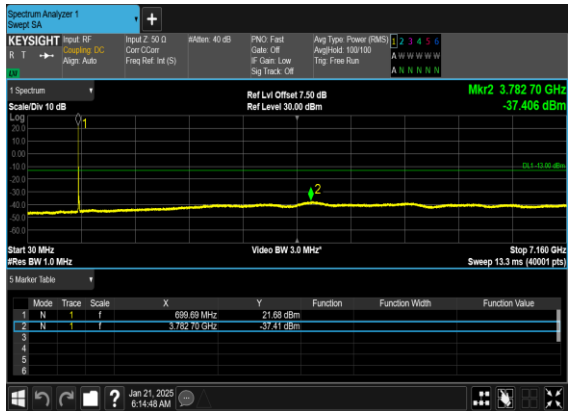



N12(10M)_DFT-s-OFDM_BPSK_Edge_1RB_Left_Mid_CH



N12(10M)_DFT-s-OFDM_QPSK_Edge_1RB_Left_Mid_CH

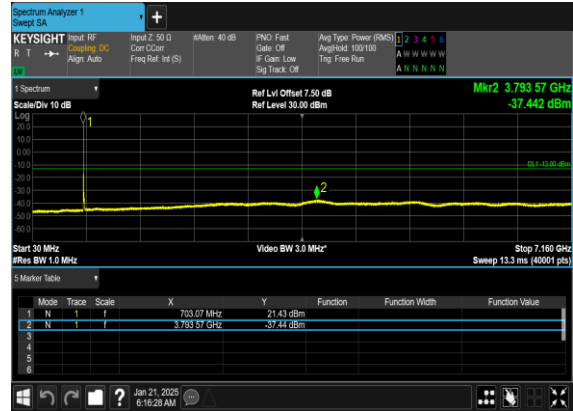

N12(10M)_DFT-s-OFDM_BPSK_Edge_1RB_Left_High_CH

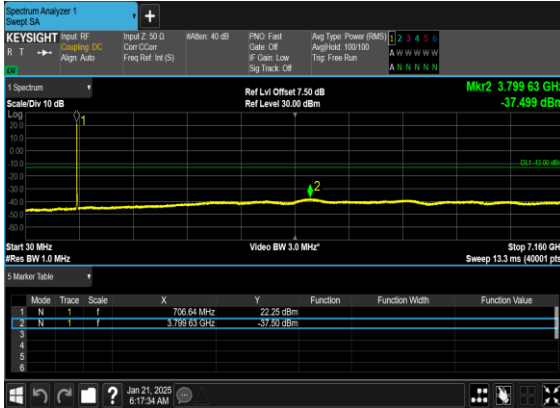

N12(10M)_DFT-s-OFDM_QPSK_Edge_1RB_Left_High_CH





N12(15M)_DFT-s-OFDM_BPSK_Edge_1RB_Left_Low_CH



N12(15M)_DFT-s-OFDM_QPSK_Edge_1RB_Left_Low_CH



N12(15M)_DFT-s-OFDM_BPSK_Edge_1RB_Left_Mid_CH

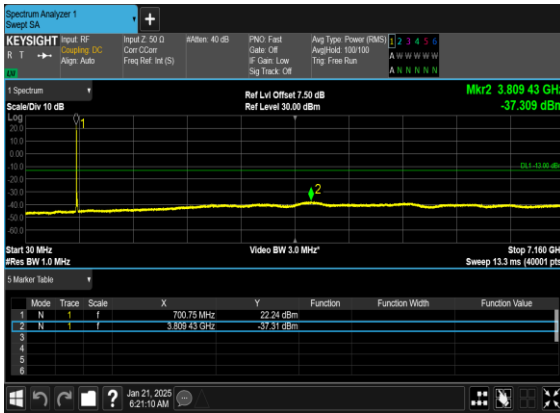

N12(15M)_DFT-s-OFDM_QPSK_Edge_1RB_Left_Mid_CH

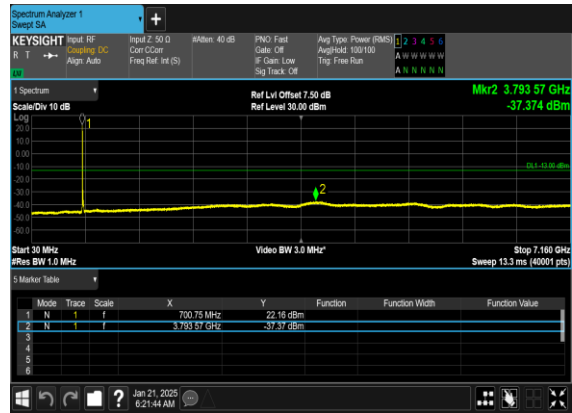



N12(15M)_DFT-s-OFDM_BPSK_Edge_1RB_Left_High_CH

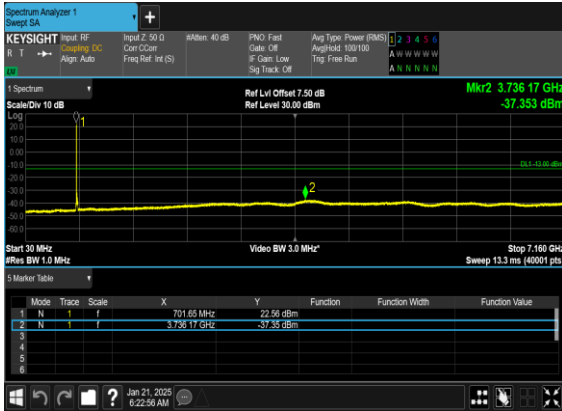

N12(15M)_DFT-s-OFDM_QPSK_Edge_1RB_Left_High_CH





Conducted Band Edge

NR Band	SCS (kHz)	Bandwidth (MHz)	Arfcn	Freq (MHz)	Modulation	RB	Result	Verdict
12	15	5	140300	701.5	DFT-s-OFDM BPSK	1@0	see graph	PASS
12	15	5	140300	701.5	DFT-s-OFDM QPSK	1@0	see graph	PASS
12	15	5	140300	701.5	DFT-s-OFDM BPSK	25@0	see graph	PASS
12	15	5	140300	701.5	DFT-s-OFDM QPSK	25@0	see graph	PASS
12	15	5	142700	713.5	DFT-s-OFDM BPSK	1@24	see graph	PASS
12	15	5	142700	713.5	DFT-s-OFDM QPSK	1@24	see graph	PASS
12	15	5	142700	713.5	DFT-s-OFDM BPSK	25@0	see graph	PASS
12	15	5	142700	713.5	DFT-s-OFDM QPSK	25@0	see graph	PASS
12	15	10	140800	704.0	DFT-s-OFDM BPSK	1@0	see graph	PASS
12	15	10	140800	704.0	DFT-s-OFDM QPSK	1@0	see graph	PASS
12	15	10	140800	704.0	DFT-s-OFDM BPSK	50@0	see graph	PASS
12	15	10	140800	704.0	DFT-s-OFDM QPSK	50@0	see graph	PASS
12	15	10	142200	711.0	DFT-s-OFDM BPSK	1@51	see graph	PASS
12	15	10	142200	711.0	DFT-s-OFDM QPSK	1@51	see graph	PASS
12	15	10	142200	711.0	DFT-s-OFDM BPSK	50@0	see graph	PASS
12	15	10	142200	711.0	DFT-s-OFDM QPSK	50@0	see graph	PASS
12	15	15	141300	706.5	DFT-s-OFDM BPSK	1@0	see graph	PASS
12	15	15	141300	706.5	DFT-s-OFDM QPSK	1@0	see graph	PASS
12	15	15	141300	706.5	DFT-s-OFDM BPSK	75@0	see graph	PASS
12	15	15	141300	706.5	DFT-s-OFDM QPSK	75@0	see graph	PASS



12	15	15	141700	708.5	DFT-s-OFDM BPSK	1@78	see graph	PASS
12	15	15	141700	708.5	DFT-s-OFDM QPSK	1@78	see graph	PASS
12	15	15	141700	708.5	DFT-s-OFDM BPSK	75@0	see graph	PASS
12	15	15	141700	708.5	DFT-s-OFDM QPSK	75@0	see graph	PASS



N12(5M)_DFT-s-OFDM_BPSK_Edge_1RB_Left_Low_CH

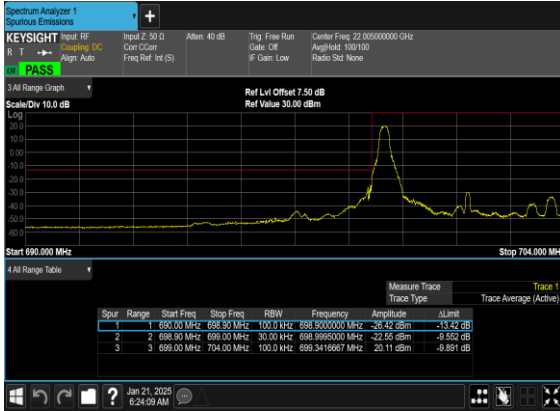

N12(5M)_DFT-s-OFDM_QPSK_Edge_1RB_Left_Low_CH

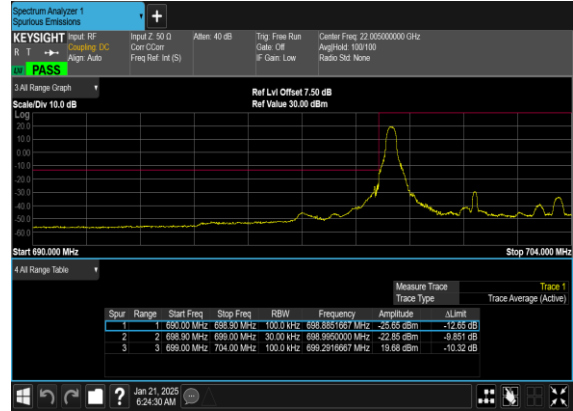

N12(5M)_DFT-s-OFDM_BPSK_Outer_Full_Low_CH

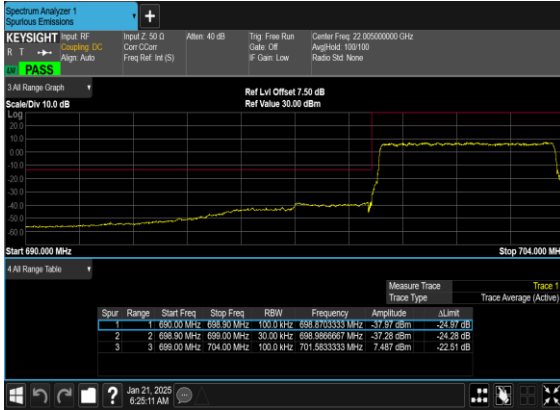

N12(5M)_DFT-s-OFDM_QPSK_Outer_Full_Low_CH

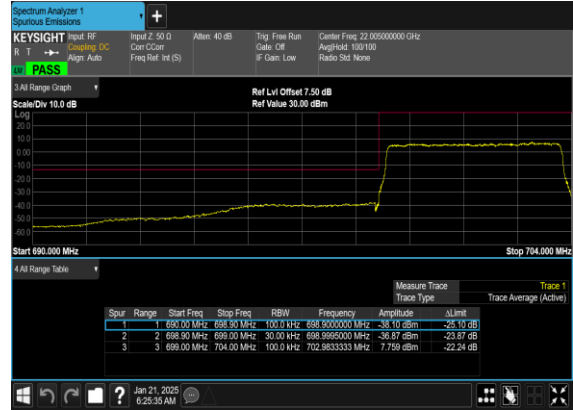



N12(5M)_DFT-s-OFDM_BPSK_Edge_1RB_Right_High_CH

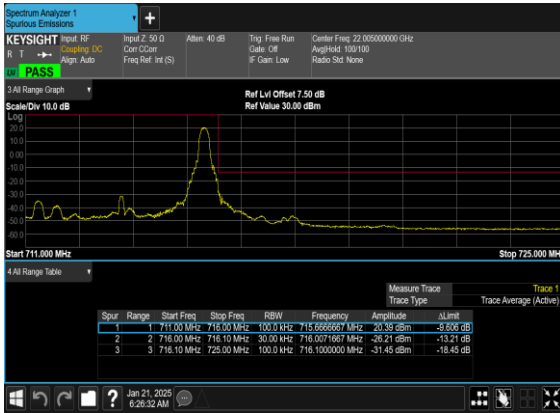

N12(5M)_DFT-s-OFDM_QPSK_Edge_1RB_Right_High_CH

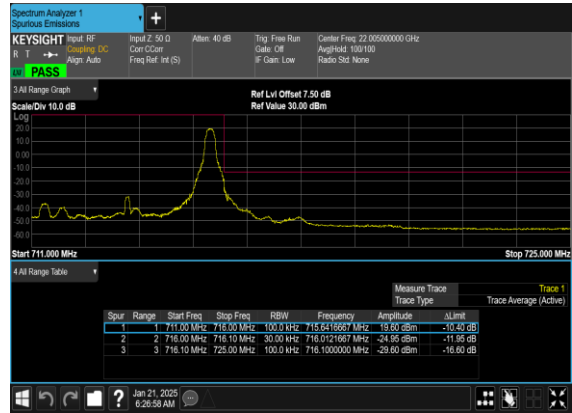

N12(5M)_DFT-s-OFDM_BPSK_Outer_Full_High_CH

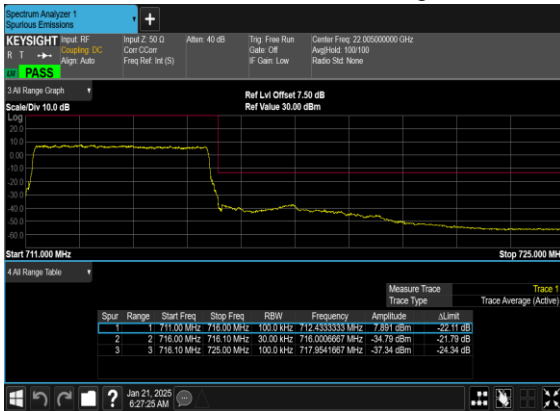

N12(5M)_DFT-s-OFDM_QPSK_Outer_Full_High_CH





N12(10M)_DFT-s-OFDM_BPSK_Edge_1RB_Left_Low_CH

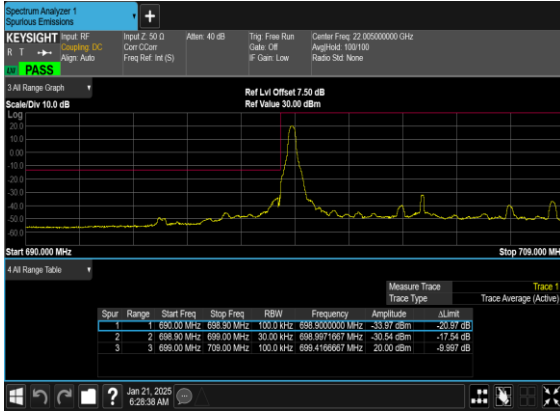

N12(10M)_DFT-s-OFDM_QPSK_Edge_1RB_Left_Low_CH



N12(10M)_DFT-s-OFDM_BPSK_Outer_Full_Low_CH



N12(10M)_DFT-s-OFDM_QPSK_Outer_Full_Low_CH

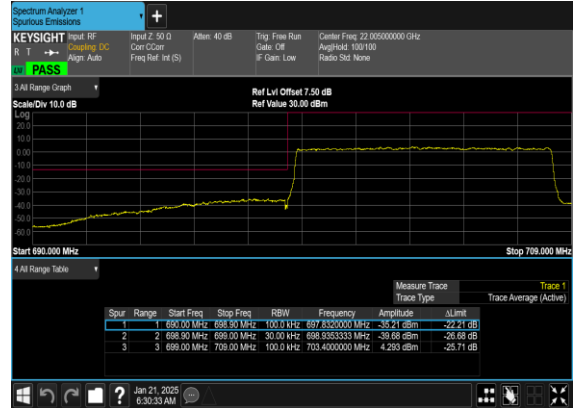



N12(10M)_DFT-s-OFDM_BPSK_Edge_1RB_Right_High_CH

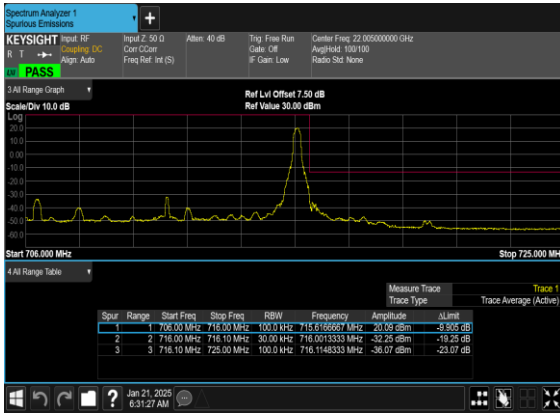

N12(10M)_DFT-s-OFDM_QPSK_Edge_1RB_Right_High_CH

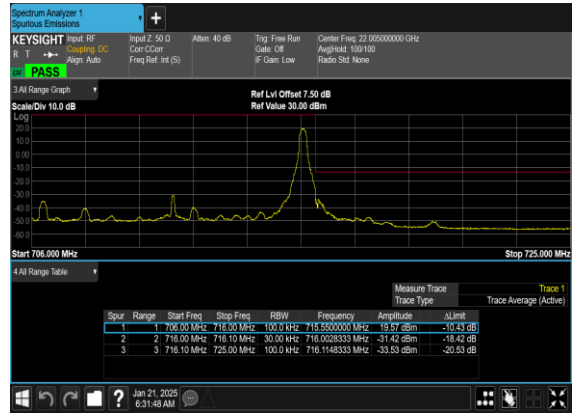

N12(10M)_DFT-s-OFDM_BPSK_Outer_Full_High_CH



N12(10M)_DFT-s-OFDM_QPSK_Outer_Full_High_CH





N12(15M)_DFT-s-OFDM_BPSK_Edge_1RB_Left_Low_CH

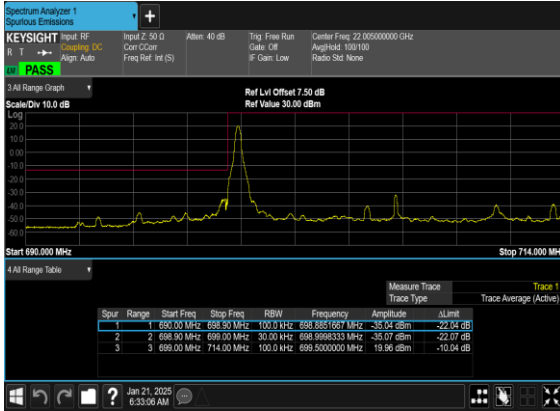

N12(15M)_DFT-s-OFDM_QPSK_Edge_1RB_Left_Low_CH

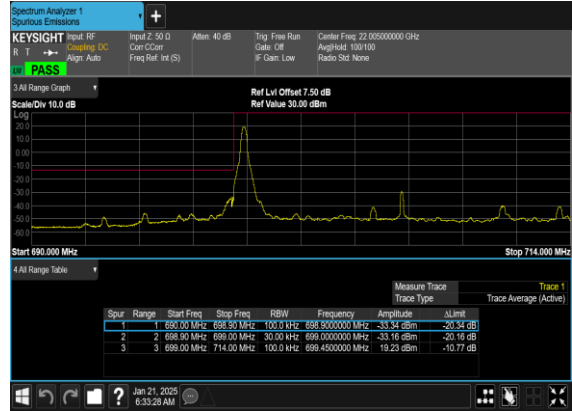

N12(15M)_DFT-s-OFDM_BPSK_Outer_Full_Low_CH

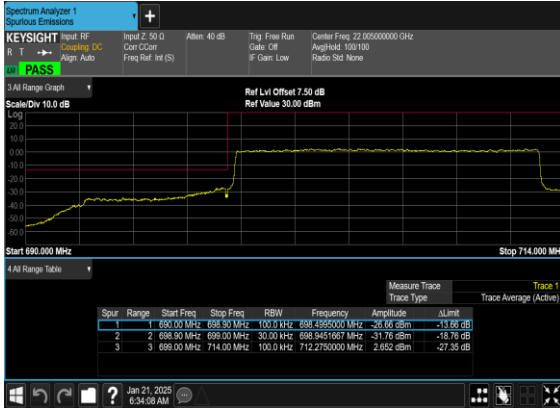

N12(15M)_DFT-s-OFDM_QPSK_Outer_Full_Low_CH

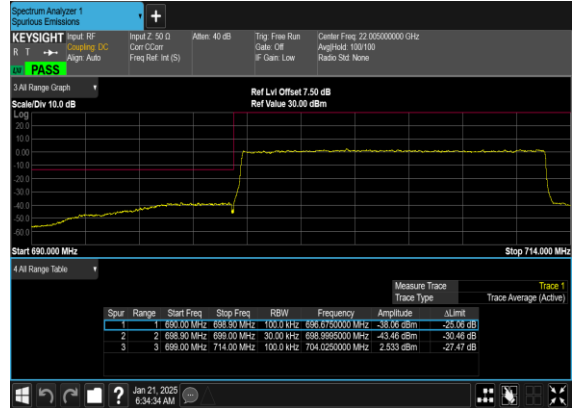



N12(15M)_DFT-s-OFDM_BPSK_Edge_1RB_Right_High_CH



N12(15M)_DFT-s-OFDM_QPSK_Edge_1RB_Right_High_CH



N12(15M)_DFT-s-OFDM_BPSK_Outer_Full_High_CH

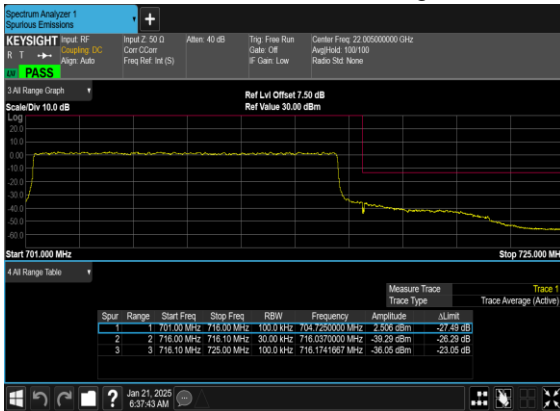

N12(15M)_DFT-s-OFDM_QPSK_Outer_Full_High_CH

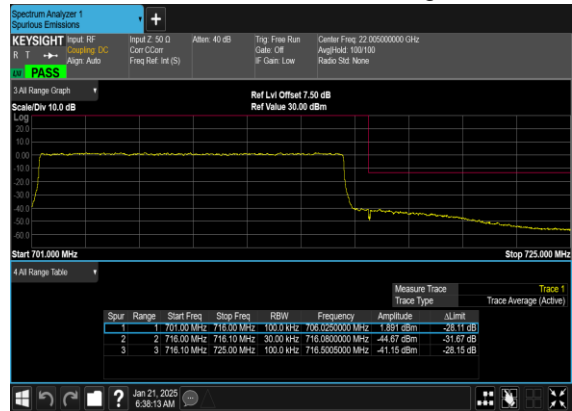



Software Version: 23.06.1602

FR1 N66 ANT0

Transmitter Conducted Output Power And EIRP, (G_T - L_c)=-2.27dB

NR Band	SCS	BandWidth	Arfcn	Freq(MHz)	Modulation	RB	Conducted Power(dBm)	EIRP(dBm)	EIRP(W)
66	15	5	342500	1712.5	DFT-s-OFDM QPSK	12@6	23	20.73	0.1183
66	15	5	342500	1712.5	DFT-s-OFDM QPSK	1@1	22.96	20.69	0.1172
66	15	5	342500	1712.5	DFT-s-OFDM QPSK	1@23	22.74	20.47	0.1114
66	15	5	342500	1712.5	DFT-s-OFDM 16 QAM	12@6	21.76	19.49	0.0889
66	15	5	342500	1712.5	DFT-s-OFDM 16 QAM	1@1	21.96	19.69	0.0931
66	15	5	342500	1712.5	DFT-s-OFDM 16 QAM	1@23	21.89	19.62	0.0916
66	15	5	349000	1745	DFT-s-OFDM QPSK	12@6	23.02	20.75	0.1189
66	15	5	349000	1745	DFT-s-OFDM QPSK	1@1	22.92	20.65	0.1161
66	15	5	349000	1745	DFT-s-OFDM QPSK	1@23	22.76	20.49	0.1119
66	15	5	349000	1745	DFT-s-OFDM 16 QAM	12@6	21.75	19.48	0.0887
66	15	5	349000	1745	DFT-s-OFDM 16 QAM	1@1	22.03	19.76	0.0946
66	15	5	349000	1745	DFT-s-OFDM 16 QAM	1@23	21.92	19.65	0.0923
66	15	5	355500	1777.5	DFT-s-OFDM QPSK	12@6	22.97	20.7	0.1175
66	15	5	355500	1777.5	DFT-s-OFDM QPSK	1@1	22.94	20.67	0.1167
66	15	5	355500	1777.5	DFT-s-OFDM QPSK	1@23	22.77	20.5	0.1122
66	15	5	355500	1777.5	DFT-s-OFDM 16 QAM	12@6	21.77	19.5	0.0891
66	15	5	355500	1777.5	DFT-s-OFDM 16 QAM	1@1	21.94	19.67	0.0927
66	15	5	355500	1777.5	DFT-s-OFDM 16 QAM	1@23	22	19.73	0.0940
66	15	10	343000	1715	DFT-s-OFDM QPSK	25@12	22.92	20.65	0.1161
66	15	10	343000	1715	DFT-s-OFDM QPSK	1@1	22.93	20.66	0.1164
66	15	10	343000	1715	DFT-s-OFDM QPSK	1@50	22.73	20.46	0.1112
66	15	10	343000	1715	DFT-s-OFDM 16 QAM	25@12	21.76	19.49	0.0889
66	15	10	343000	1715	DFT-s-OFDM 16 QAM	1@1	21.91	19.64	0.0920
66	15	10	343000	1715	DFT-s-OFDM 16 QAM	1@50	21.93	19.66	0.0925
66	15	10	349000	1745	DFT-s-OFDM QPSK	25@12	23.01	20.74	0.1186
66	15	10	349000	1745	DFT-s-OFDM QPSK	1@1	22.77	20.5	0.1122
66	15	10	349000	1745	DFT-s-OFDM QPSK	1@50	22.82	20.55	0.1135
66	15	10	349000	1745	DFT-s-OFDM 16 QAM	25@12	21.85	19.58	0.0908
66	15	10	349000	1745	DFT-s-OFDM 16 QAM	1@1	21.97	19.7	0.0933



66	15	10	349000	1745	DFT-s-OFDM 16 QAM	1@50	21.92	19.65	0.0923
66	15	10	355000	1775	DFT-s-OFDM QPSK	25@12	22.9	20.63	0.1156
66	15	10	355000	1775	DFT-s-OFDM QPSK	1@1	22.76	20.49	0.1119
66	15	10	355000	1775	DFT-s-OFDM QPSK	1@50	22.77	20.5	0.1122
66	15	10	355000	1775	DFT-s-OFDM 16 QAM	25@12	21.86	19.59	0.0910
66	15	10	355000	1775	DFT-s-OFDM 16 QAM	1@1	21.95	19.68	0.0929
66	15	10	355000	1775	DFT-s-OFDM 16 QAM	1@50	21.97	19.7	0.0933
66	15	15	343500	1717.5	DFT-s-OFDM QPSK	36@18	22.9	20.63	0.1156
66	15	15	343500	1717.5	DFT-s-OFDM QPSK	1@1	22.82	20.55	0.1135
66	15	15	343500	1717.5	DFT-s-OFDM QPSK	1@77	22.76	20.49	0.1119
66	15	15	343500	1717.5	DFT-s-OFDM 16 QAM	36@18	21.67	19.4	0.0871
66	15	15	343500	1717.5	DFT-s-OFDM 16 QAM	1@1	21.89	19.62	0.0916
66	15	15	343500	1717.5	DFT-s-OFDM 16 QAM	1@77	21.88	19.61	0.0914
66	15	15	349000	1745	DFT-s-OFDM QPSK	36@18	22.93	20.66	0.1164
66	15	15	349000	1745	DFT-s-OFDM QPSK	1@1	22.88	20.61	0.1151
66	15	15	349000	1745	DFT-s-OFDM QPSK	1@77	22.75	20.48	0.1117
66	15	15	349000	1745	DFT-s-OFDM 16 QAM	36@18	21.76	19.49	0.0889
66	15	15	349000	1745	DFT-s-OFDM 16 QAM	1@1	21.92	19.65	0.0923
66	15	15	349000	1745	DFT-s-OFDM 16 QAM	1@77	21.85	19.58	0.0908
66	15	15	354500	1772.5	DFT-s-OFDM QPSK	36@18	22.94	20.67	0.1167
66	15	15	354500	1772.5	DFT-s-OFDM QPSK	1@1	22.84	20.57	0.1140
66	15	15	354500	1772.5	DFT-s-OFDM QPSK	1@77	22.81	20.54	0.1132
66	15	15	354500	1772.5	DFT-s-OFDM 16 QAM	36@18	21.72	19.45	0.0881
66	15	15	354500	1772.5	DFT-s-OFDM 16 QAM	1@1	21.82	19.55	0.0902
66	15	15	354500	1772.5	DFT-s-OFDM 16 QAM	1@77	21.88	19.61	0.0914
66	15	20	344000	1720	DFT-s-OFDM QPSK	50@25	22.86	20.59	0.1146
66	15	20	344000	1720	DFT-s-OFDM QPSK	1@1	22.83	20.56	0.1138
66	15	20	344000	1720	DFT-s-OFDM QPSK	1@104	22.72	20.45	0.1109
66	15	20	344000	1720	DFT-s-OFDM 16 QAM	50@25	21.66	19.39	0.0869
66	15	20	344000	1720	DFT-s-OFDM 16 QAM	1@1	21.82	19.55	0.0902
66	15	20	344000	1720	DFT-s-OFDM 16 QAM	1@104	21.8	19.53	0.0897
66	15	20	349000	1745	DFT-s-OFDM QPSK	50@25	22.85	20.58	0.1143
66	15	20	349000	1745	DFT-s-OFDM QPSK	1@1	22.8	20.53	0.1130
66	15	20	349000	1745	DFT-s-OFDM QPSK	1@104	22.66	20.39	0.1094
66	15	20	349000	1745	DFT-s-OFDM 16 QAM	50@25	21.78	19.51	0.0893
66	15	20	349000	1745	DFT-s-OFDM 16 QAM	1@1	21.92	19.65	0.0923



66	15	20	349000	1745	DFT-s-OFDM 16 QAM	1@104	21.86	19.59	0.0910
66	15	20	354000	1770	DFT-s-OFDM QPSK	50@25	22.89	20.62	0.1153
66	15	20	354000	1770	DFT-s-OFDM QPSK	1@1	22.68	20.41	0.1099
66	15	20	354000	1770	DFT-s-OFDM QPSK	1@104	22.76	20.49	0.1119
66	15	20	354000	1770	DFT-s-OFDM 16 QAM	50@25	21.74	19.47	0.0885
66	15	20	354000	1770	DFT-s-OFDM 16 QAM	1@1	21.85	19.58	0.0908
66	15	20	354000	1770	DFT-s-OFDM 16 QAM	1@104	21.89	19.62	0.0916
66	15	25	344500	1722.5	DFT-s-OFDM QPSK	64@32	22.68	20.41	0.1099
66	15	25	344500	1722.5	DFT-s-OFDM QPSK	1@1	22.58	20.31	0.1074
66	15	25	344500	1722.5	DFT-s-OFDM QPSK	1@131	22.44	20.17	0.1040
66	15	25	344500	1722.5	DFT-s-OFDM 16 QAM	64@32	21.45	19.18	0.0828
66	15	25	344500	1722.5	DFT-s-OFDM 16 QAM	1@1	21.66	19.39	0.0869
66	15	25	344500	1722.5	DFT-s-OFDM 16 QAM	1@131	21.6	19.33	0.0857
66	15	25	349000	1745	DFT-s-OFDM QPSK	64@32	22.76	20.49	0.1119
66	15	25	349000	1745	DFT-s-OFDM QPSK	1@1	22.47	20.2	0.1047
66	15	25	349000	1745	DFT-s-OFDM QPSK	1@131	22.42	20.15	0.1035
66	15	25	349000	1745	DFT-s-OFDM 16 QAM	64@32	21.58	19.31	0.0853
66	15	25	349000	1745	DFT-s-OFDM 16 QAM	1@1	21.58	19.31	0.0853
66	15	25	349000	1745	DFT-s-OFDM 16 QAM	1@131	21.73	19.46	0.0883
66	15	25	353500	1767.5	DFT-s-OFDM QPSK	64@32	22.77	20.5	0.1122
66	15	25	353500	1767.5	DFT-s-OFDM QPSK	1@1	22.49	20.22	0.1052
66	15	25	353500	1767.5	DFT-s-OFDM QPSK	1@131	22.45	20.18	0.1042
66	15	25	353500	1767.5	DFT-s-OFDM 16 QAM	64@32	21.57	19.3	0.0851
66	15	25	353500	1767.5	DFT-s-OFDM 16 QAM	1@1	21.55	19.28	0.0847
66	15	25	353500	1767.5	DFT-s-OFDM 16 QAM	1@131	21.6	19.33	0.0857
66	15	30	345000	1725	DFT-s-OFDM QPSK	80@40	22.62	20.35	0.1084
66	15	30	345000	1725	DFT-s-OFDM QPSK	1@1	22.66	20.39	0.1094
66	15	30	345000	1725	DFT-s-OFDM QPSK	1@158	22.5	20.23	0.1054
66	15	30	345000	1725	DFT-s-OFDM 16 QAM	80@40	21.38	19.11	0.0815
66	15	30	345000	1725	DFT-s-OFDM 16 QAM	1@1	21.65	19.38	0.0867
66	15	30	345000	1725	DFT-s-OFDM 16 QAM	1@158	21.6	19.33	0.0857
66	15	30	349000	1745	DFT-s-OFDM QPSK	80@40	22.7	20.43	0.1104
66	15	30	349000	1745	DFT-s-OFDM QPSK	1@1	22.56	20.29	0.1069
66	15	30	349000	1745	DFT-s-OFDM QPSK	1@158	22.01	19.74	0.0942
66	15	30	349000	1745	DFT-s-OFDM 16 QAM	80@40	21.5	19.23	0.0838
66	15	30	349000	1745	DFT-s-OFDM 16 QAM	1@1	21.06	18.79	0.0757



66	15	30	349000	1745	DFT-s-OFDM 16 QAM	1@158	21.18	18.91	0.0778
66	15	30	353000	1765	DFT-s-OFDM QPSK	80@40	22.7	20.43	0.1104
66	15	30	353000	1765	DFT-s-OFDM QPSK	1@1	22.59	20.32	0.1076
66	15	30	353000	1765	DFT-s-OFDM QPSK	1@158	22.53	20.26	0.1062
66	15	30	353000	1765	DFT-s-OFDM 16 QAM	80@40	21.54	19.27	0.0845
66	15	30	353000	1765	DFT-s-OFDM 16 QAM	1@1	21.56	19.29	0.0849
66	15	30	353000	1765	DFT-s-OFDM 16 QAM	1@158	21.64	19.37	0.0865
66	15	35	345500	1727.5	DFT-s-OFDM QPSK	90@45	22.67	20.4	0.1096
66	15	35	345500	1727.5	DFT-s-OFDM QPSK	1@1	22.47	20.2	0.1047
66	15	35	345500	1727.5	DFT-s-OFDM QPSK	1@186	22.45	20.18	0.1042
66	15	35	345500	1727.5	DFT-s-OFDM 16 QAM	90@45	21.55	19.28	0.0847
66	15	35	345500	1727.5	DFT-s-OFDM 16 QAM	1@1	21.56	19.29	0.0849
66	15	35	345500	1727.5	DFT-s-OFDM 16 QAM	1@186	21.72	19.45	0.0881
66	15	35	349000	1745	DFT-s-OFDM QPSK	90@45	22.69	20.42	0.1102
66	15	35	349000	1745	DFT-s-OFDM QPSK	1@1	22.42	20.15	0.1035
66	15	35	349000	1745	DFT-s-OFDM QPSK	1@186	22.53	20.26	0.1062
66	15	35	349000	1745	DFT-s-OFDM 16 QAM	90@45	21.52	19.25	0.0841
66	15	35	349000	1745	DFT-s-OFDM 16 QAM	1@1	21.62	19.35	0.0861
66	15	35	349000	1745	DFT-s-OFDM 16 QAM	1@186	21.68	19.41	0.0873
66	15	35	352500	1762.5	DFT-s-OFDM QPSK	90@45	22.6	20.33	0.1079
66	15	35	352500	1762.5	DFT-s-OFDM QPSK	1@1	22.38	20.11	0.1026
66	15	35	352500	1762.5	DFT-s-OFDM QPSK	1@186	22.48	20.21	0.1050
66	15	35	352500	1762.5	DFT-s-OFDM 16 QAM	90@45	21.48	19.21	0.0834
66	15	35	352500	1762.5	DFT-s-OFDM 16 QAM	1@1	21.53	19.26	0.0843
66	15	35	352500	1762.5	DFT-s-OFDM 16 QAM	1@186	21.62	19.35	0.0861
66	15	40	346000	1730	DFT-s-OFDM QPSK	108@54	22.72	20.45	0.1109
66	15	40	346000	1730	DFT-s-OFDM QPSK	1@1	22.57	20.3	0.1072
66	15	40	346000	1730	DFT-s-OFDM QPSK	1@214	22.58	20.31	0.1074
66	15	40	346000	1730	DFT-s-OFDM 16 QAM	108@54	21.53	19.26	0.0843
66	15	40	346000	1730	DFT-s-OFDM 16 QAM	1@1	21.62	19.35	0.0861
66	15	40	346000	1730	DFT-s-OFDM 16 QAM	1@214	21.6	19.33	0.0857
66	15	40	349000	1745	DFT-s-OFDM QPSK	108@54	22.7	20.43	0.1104
66	15	40	349000	1745	DFT-s-OFDM QPSK	1@1	21.92	19.65	0.0923
66	15	40	349000	1745	DFT-s-OFDM QPSK	1@214	22.02	19.75	0.0944
66	15	40	349000	1745	DFT-s-OFDM 16 QAM	108@54	21.47	19.2	0.0832
66	15	40	349000	1745	DFT-s-OFDM 16 QAM	1@1	21	18.73	0.0746



66	15	40	349000	1745	DFT-s-OFDM 16 QAM	1@214	21.16	18.89	0.0774
66	15	40	352000	1760	DFT-s-OFDM QPSK	108@54	22.57	20.3	0.1072
66	15	40	352000	1760	DFT-s-OFDM QPSK	1@1	22.45	20.18	0.1042
66	15	40	352000	1760	DFT-s-OFDM QPSK	1@214	22.42	20.15	0.1035
66	15	40	352000	1760	DFT-s-OFDM 16 QAM	108@54	21.48	19.21	0.0834
66	15	40	352000	1760	DFT-s-OFDM 16 QAM	1@1	21.55	19.28	0.0847
66	15	40	352000	1760	DFT-s-OFDM 16 QAM	1@214	20.99	18.72	0.0745
66	15	45	346500	1732.5	DFT-s-OFDM PI/2 BPSK	120@60	23.05	20.78	0.1197
66	15	45	346500	1732.5	DFT-s-OFDM PI/2 BPSK	1@1	22.92	20.65	0.1161
66	15	45	346500	1732.5	DFT-s-OFDM PI/2 BPSK	1@240	22.94	20.67	0.1167
66	15	45	346500	1732.5	DFT-s-OFDM QPSK	120@60	23.09	20.82	0.1208
66	15	45	346500	1732.5	DFT-s-OFDM QPSK	1@1	23.1	20.83	0.1211
66	15	45	346500	1732.5	DFT-s-OFDM QPSK	1@240	22.95	20.68	0.1169
66	15	45	346500	1732.5	DFT-s-OFDM 16 QAM	120@60	22.1	19.83	0.0962
66	15	45	346500	1732.5	DFT-s-OFDM 16 QAM	1@1	22.08	19.81	0.0957
66	15	45	346500	1732.5	DFT-s-OFDM 16 QAM	1@240	22.1	19.83	0.0962
66	15	45	346500	1732.5	DFT-s-OFDM 64 QAM	120@60	20.48	18.21	0.0662
66	15	45	346500	1732.5	DFT-s-OFDM 64 QAM	1@1	20.33	18.06	0.0640
66	15	45	346500	1732.5	DFT-s-OFDM 64 QAM	1@240	20.22	17.95	0.0624
66	15	45	346500	1732.5	DFT-s-OFDM 256 QAM	120@60	18.57	16.3	0.0427
66	15	45	346500	1732.5	DFT-s-OFDM 256 QAM	1@1	18.44	16.17	0.0414
66	15	45	346500	1732.5	DFT-s-OFDM 256 QAM	1@240	18.4	16.13	0.0410
66	15	45	346500	1732.5	CP-OFDM QPSK	121@60	21.46	19.19	0.0830
66	15	45	346500	1732.5	CP-OFDM QPSK	1@1	21.33	19.06	0.0805
66	15	45	346500	1732.5	CP-OFDM QPSK	1@240	21.29	19.02	0.0798
66	15	45	349000	1745	DFT-s-OFDM PI/2 BPSK	120@60	23.06	20.79	0.1199
66	15	45	349000	1745	DFT-s-OFDM PI/2 BPSK	1@1	22.78	20.51	0.1125
66	15	45	349000	1745	DFT-s-OFDM PI/2 BPSK	1@240	22.92	20.65	0.1161
66	15	45	349000	1745	DFT-s-OFDM QPSK	120@60	22.9	20.63	0.1156
66	15	45	349000	1745	DFT-s-OFDM QPSK	1@1	22.67	20.4	0.1096
66	15	45	349000	1745	DFT-s-OFDM QPSK	1@240	22.88	20.61	0.1151
66	15	45	349000	1745	DFT-s-OFDM 16 QAM	120@60	21.84	19.57	0.0906
66	15	45	349000	1745	DFT-s-OFDM 16 QAM	1@1	21.81	19.54	0.0899
66	15	45	349000	1745	DFT-s-OFDM 16 QAM	1@240	21.99	19.72	0.0938



66	15	45	349000	1745	DFT-s-OFDM 64 QAM	120@60	20.31	18.04	0.0637
66	15	45	349000	1745	DFT-s-OFDM 64 QAM	1@1	19.95	17.68	0.0586
66	15	45	349000	1745	DFT-s-OFDM 64 QAM	1@240	20.11	17.84	0.0608
66	15	45	349000	1745	DFT-s-OFDM 256 QAM	120@60	18.52	16.25	0.0422
66	15	45	349000	1745	DFT-s-OFDM 256 QAM	1@1	18.35	16.08	0.0406
66	15	45	349000	1745	DFT-s-OFDM 256 QAM	1@240	18.59	16.32	0.0429
66	15	45	349000	1745	CP-OFDM QPSK	121@60	21.31	19.04	0.0802
66	15	45	349000	1745	CP-OFDM QPSK	1@1	21.1	18.83	0.0764
66	15	45	349000	1745	CP-OFDM QPSK	1@240	21.16	18.89	0.0774
66	15	45	351500	1757.5	DFT-s-OFDM PI/2 BPSK	120@60	22.96	20.69	0.1172
66	15	45	351500	1757.5	DFT-s-OFDM PI/2 BPSK	1@1	22.68	20.41	0.1099
66	15	45	351500	1757.5	DFT-s-OFDM PI/2 BPSK	1@240	22.64	20.37	0.1089
66	15	45	351500	1757.5	DFT-s-OFDM QPSK	120@60	22.81	20.54	0.1132
66	15	45	351500	1757.5	DFT-s-OFDM QPSK	1@1	22.58	20.31	0.1074
66	15	45	351500	1757.5	DFT-s-OFDM QPSK	1@240	22.67	20.4	0.1096
66	15	45	351500	1757.5	DFT-s-OFDM 16 QAM	120@60	21.81	19.54	0.0899
66	15	45	351500	1757.5	DFT-s-OFDM 16 QAM	1@1	21.72	19.45	0.0881
66	15	45	351500	1757.5	DFT-s-OFDM 16 QAM	1@240	21.81	19.54	0.0899
66	15	45	351500	1757.5	DFT-s-OFDM 64 QAM	120@60	20.27	18	0.0631
66	15	45	351500	1757.5	DFT-s-OFDM 64 QAM	1@1	19.93	17.66	0.0583
66	15	45	351500	1757.5	DFT-s-OFDM 64 QAM	1@240	19.94	17.67	0.0585
66	15	45	351500	1757.5	DFT-s-OFDM 256 QAM	120@60	18.5	16.23	0.0420
66	15	45	351500	1757.5	DFT-s-OFDM 256 QAM	1@1	18.25	15.98	0.0396
66	15	45	351500	1757.5	DFT-s-OFDM 256 QAM	1@240	18.37	16.1	0.0407
66	15	45	351500	1757.5	CP-OFDM QPSK	121@60	21.22	18.95	0.0785
66	15	45	351500	1757.5	CP-OFDM QPSK	1@1	20.98	18.71	0.0743
66	15	45	351500	1757.5	CP-OFDM QPSK	1@240	21.04	18.77	0.0753



Frequency Stability

NR Band	SCS (kHz)	Bandwidth (MHz)	Arfcn	Freq (MHz)	Modulation	RB	Deviation (Hz)	Verdict	Environment
66	15	20	349000	1745.0	DFT-s-OFDM QPSK	100@0	17.3	PASS	NV
66	15	20	349000	1745.0	DFT-s-OFDM QPSK	100@0	15.3	PASS	LV
66	15	20	349000	1745.0	DFT-s-OFDM QPSK	100@0	15.0	PASS	HV
66	15	20	349000	1745.0	DFT-s-OFDM QPSK	100@0	13.2	PASS	-30°C
66	15	20	349000	1745.0	DFT-s-OFDM QPSK	100@0	11.0	PASS	-20°C
66	15	20	349000	1745.0	DFT-s-OFDM QPSK	100@0	14.8	PASS	-10°C
66	15	20	349000	1745.0	DFT-s-OFDM QPSK	100@0	16.3	PASS	0°C
66	15	20	349000	1745.0	DFT-s-OFDM QPSK	100@0	17.6	PASS	10°C
66	15	20	349000	1745.0	DFT-s-OFDM QPSK	100@0	13.7	PASS	20°C
66	15	20	349000	1745.0	DFT-s-OFDM QPSK	100@0	11.3	PASS	30°C
66	15	20	349000	1745.0	DFT-s-OFDM QPSK	100@0	11.6	PASS	40°C
66	15	20	349000	1745.0	DFT-s-OFDM QPSK	100@0	19.1	PASS	50°C

|MAX(Δf)| = 19.1 Hz

Frequency Stability	Frequency (MHz)	Limit Line	Result
$f_L - \text{MAX}(\Delta f) $	1710.489481	$\geq 1710 \text{ MHz}$	PASS
$f_H + \text{MAX}(\Delta f) $	1778.391619	$\leq 1780 \text{ MHz}$	



Peak to Average Ratio

NR Band	SCS (kHz)	Bandwidth (MHz)	Arfcn	Freq (MHz)	Modulation	RB	Result (dB)	Limit (dB)	Verdict
66	15	20	349000	1745.0	DFT-s-OFDM PI/2 BPSK	100@0	4.15	13	PASS
66	15	20	349000	1745.0	DFT-s-OFDM QPSK	100@0	5.18	13	PASS

N66(20M)_DFT-s-OFDM_PI_2-BPSK_Outer_Full_Mid_CH



N66(20M)_DFT-s-OFDM_QPSK_Outer_Full_Mid_CH

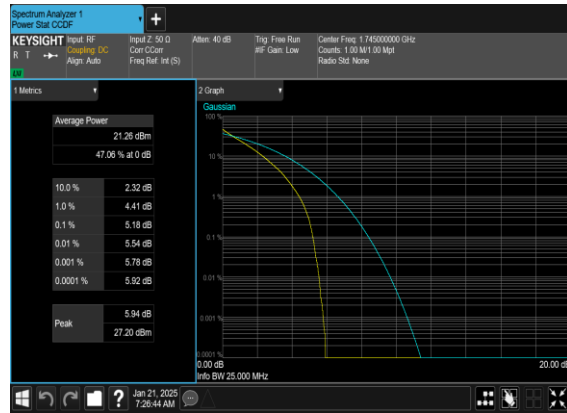



Occupied Bandwidth

NR Band	SCS (kHz)	Bandwidth (MHz)	Arfcn	Freq (MHz)	Modulation	RB	OBW (MHz)	26dB BW (MHz)
66	15	5	349000	1745.0	CP-OFDM QPSK	25@0	4.4607	4.792
66	15	5	349000	1745.0	CP-OFDM 16 QAM	25@0	4.468	4.792
66	15	5	349000	1745.0	CP-OFDM 64 QAM	25@0	4.4762	4.806
66	15	5	349000	1745.0	CP-OFDM 256 QAM	25@0	4.4738	4.796
66	15	10	349000	1745.0	CP-OFDM QPSK	52@0	9.2707	9.713
66	15	10	349000	1745.0	CP-OFDM 16 QAM	52@0	9.2665	9.693
66	15	10	349000	1745.0	CP-OFDM 64 QAM	52@0	9.2901	9.695
66	15	10	349000	1745.0	CP-OFDM 256 QAM	52@0	9.2654	9.708
66	15	15	349000	1745.0	CP-OFDM QPSK	79@0	14.099	14.66
66	15	15	349000	1745.0	CP-OFDM 16 QAM	79@0	14.076	14.69
66	15	15	349000	1745.0	CP-OFDM 64 QAM	79@0	14.104	14.67
66	15	15	349000	1745.0	CP-OFDM 256 QAM	79@0	14.101	14.69
66	15	20	349000	1745.0	CP-OFDM QPSK	106@0	18.923	19.69
66	15	20	349000	1745.0	CP-OFDM 16 QAM	106@0	18.87	19.63
66	15	20	349000	1745.0	CP-OFDM 64 QAM	106@0	18.905	19.69
66	15	20	349000	1745.0	CP-OFDM 256 QAM	106@0	18.897	19.63
66	15	25	349000	1745.0	CP-OFDM QPSK	133@0	23.726	24.62
66	15	25	349000	1745.0	CP-OFDM 16 QAM	133@0	23.675	24.75
66	15	25	349000	1745.0	CP-OFDM 64 QAM	133@0	23.699	24.66
66	15	25	349000	1745.0	CP-OFDM 256 QAM	133@0	23.73	24.64
66	15	30	349000	1745.0	CP-OFDM QPSK	160@0	28.597	29.75
66	15	30	349000	1745.0	CP-OFDM 16 QAM	160@0	28.519	29.68



66	15	30	349000	1745.0	CP-OFDM 64 QAM	160@0	28.518	29.56
66	15	30	349000	1745.0	CP-OFDM 256 QAM	160@0	28.51	29.68
66	15	35	349000	1745.0	CP-OFDM QPSK	188@0	33.566	34.87
66	15	35	349000	1745.0	CP-OFDM 16 QAM	188@0	33.481	34.74
66	15	35	349000	1745.0	CP-OFDM 64 QAM	188@0	33.597	34.69
66	15	35	349000	1745.0	CP-OFDM 256 QAM	188@0	33.538	34.78
66	15	40	349000	1745.0	CP-OFDM QPSK	216@0	38.538	39.89
66	15	40	349000	1745.0	CP-OFDM 16 QAM	216@0	38.617	39.89
66	15	40	349000	1745.0	CP-OFDM 64 QAM	216@0	38.53	39.96
66	15	40	349000	1745.0	CP-OFDM 256 QAM	216@0	38.549	39.88
66	15	45	349000	1745.0	CP-OFDM QPSK	242@0	43.182	44.61
66	15	45	349000	1745.0	CP-OFDM 16 QAM	242@0	43.299	44.65
66	15	45	349000	1745.0	CP-OFDM 64 QAM	242@0	43.199	44.68
66	15	45	349000	1745.0	CP-OFDM 256 QAM	242@0	43.122	44.73



N66(5M)_CP-OFDM_QPSK_Outer_Full_Mid_CH



N66(5M)_CP-OFDM_16_QAM_Outer_Full_Mid_CH

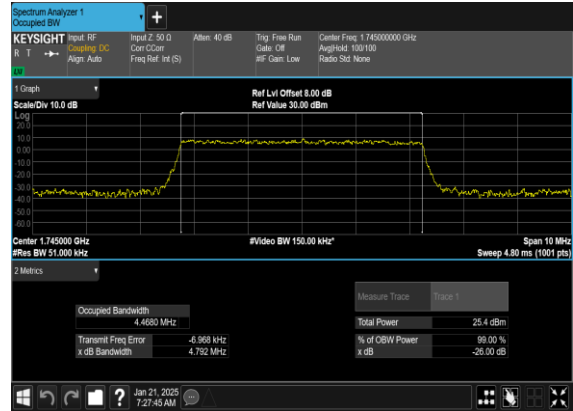

N66(5M)_CP-OFDM_64_QAM_Outer_Full_Mid_CH

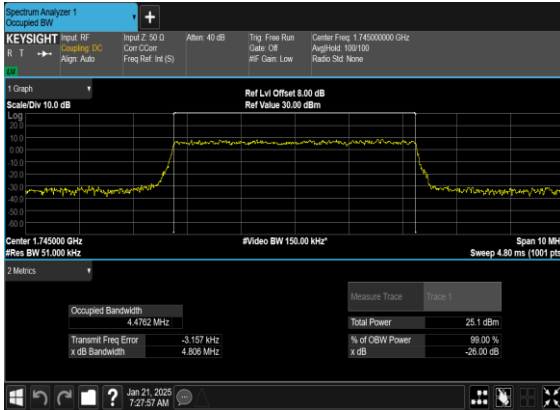

N66(5M)_CP-OFDM_256_QAM_Outer_Full_Mid_CH

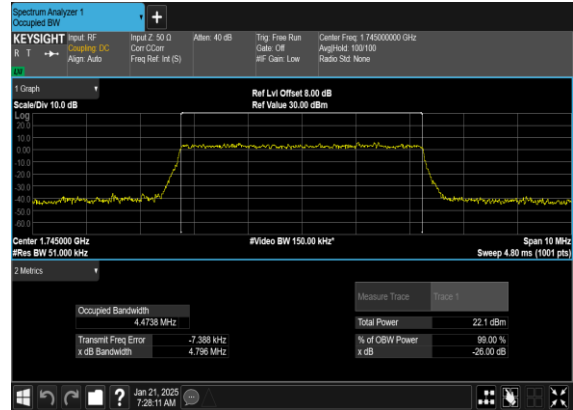



N66(10M)_CP-OFDM_QPSK_Outer_Full_Mid_CH

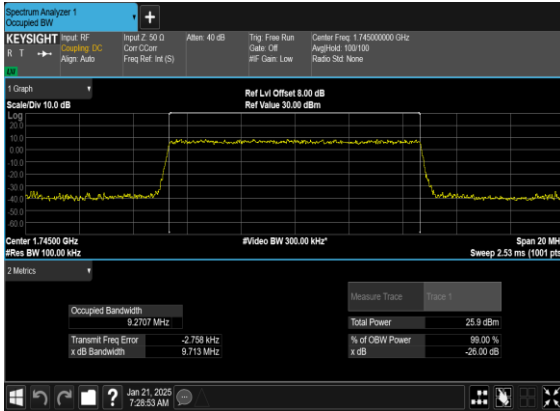

N66(10M)_CP-OFDM_16QAM_Outer_Full_Mid_CH

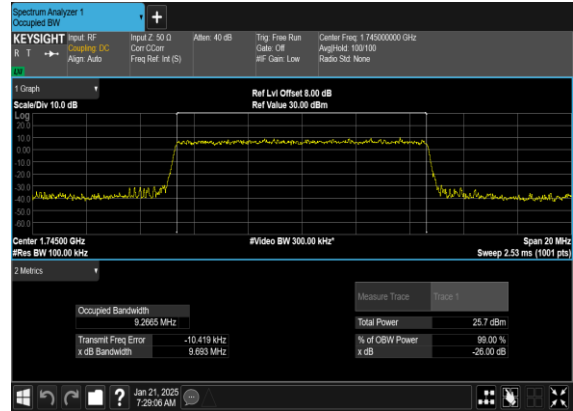

N66(10M)_CP-OFDM_64QAM_Outer_Full_Mid_CH

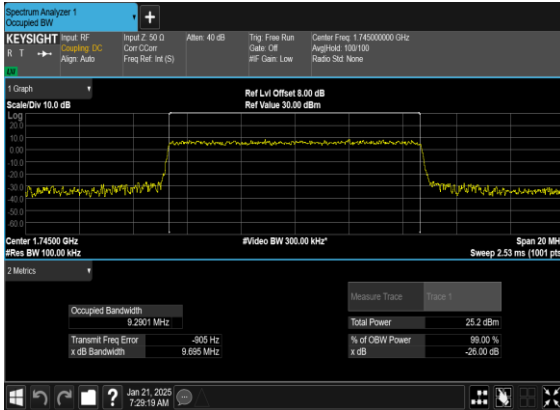

N66(10M)_CP-OFDM_256QAM_Outer_Full_Mid_CH





N66(15M)_CP-OFDM_QPSK_Outer_Full_Mid_CH

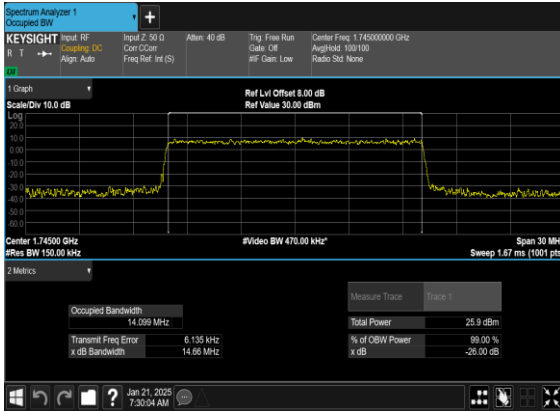

N66(15M)_CP-OFDM_16QAM_Outer_Full_Mid_CH

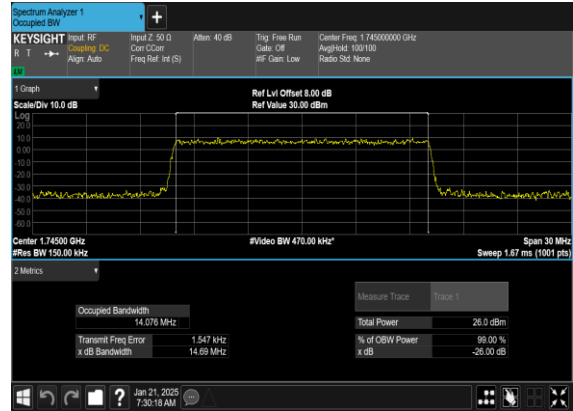

N66(15M)_CP-OFDM_64QAM_Outer_Full_Mid_CH

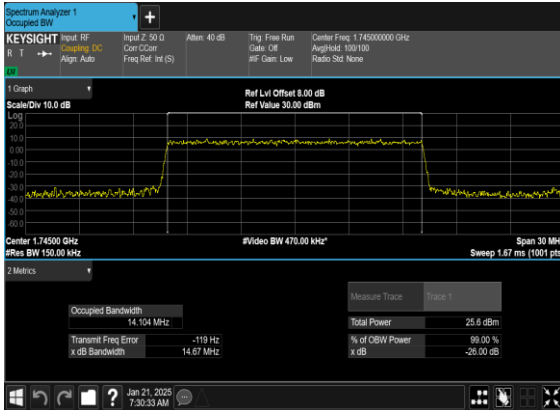

N66(15M)_CP-OFDM_256QAM_Outer_Full_Mid_CH

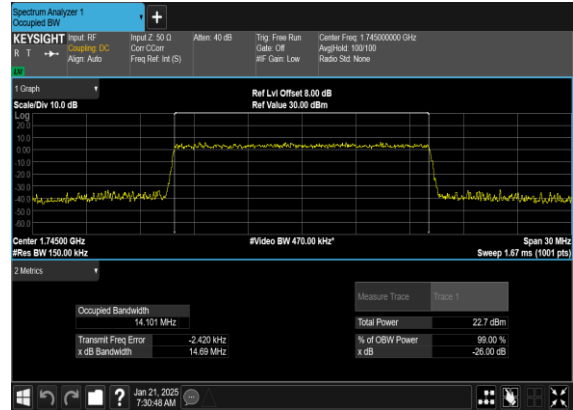



N66(20M)_CP-OFDM_QPSK_Outer_Full_Mid_CH

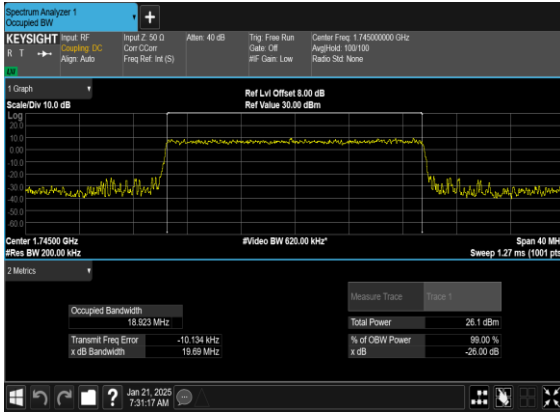

N66(20M)_CP-OFDM_16QAM_Outer_Full_Mid_CH

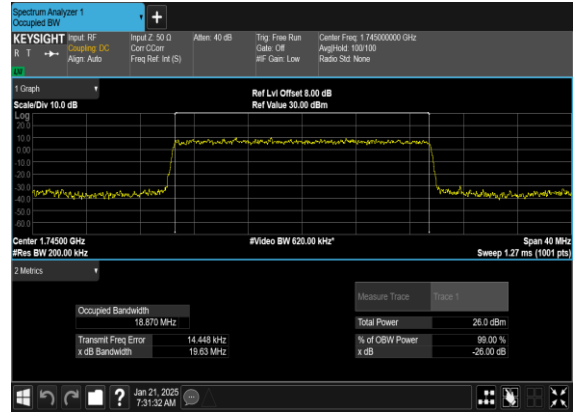

N66(20M)_CP-OFDM_64QAM_Outer_Full_Mid_CH

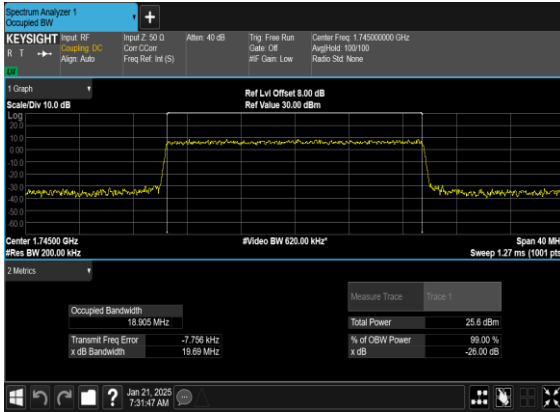

N66(20M)_CP-OFDM_256QAM_Outer_Full_Mid_CH

