



FCC RF Test Report

APPLICANT : Motorola Mobility LLC
EQUIPMENT : Mobile Cellular Phone
BRAND NAME : Motorola
MODEL NAME : XT2515-1, XT2515-2, XT2515-3, XT2515V
FCC ID : IHDT56AU5
STANDARD : 47 CFR Part 96
CLASSIFICATION : Citizens Band End User Devices (CBE)
EQUIPMENT TYPE : End User Equipment
TEST DATE(S) : Sep. 24, 2024 ~ Oct. 08, 2024

We, Sporton International Inc. (Kunshan), would like to declare that the tested sample has been evaluated in accordance with the procedures given in ANSI C63.26-2015 and shown compliance with the applicable technical standards.

The test results in this report apply exclusively to the tested model / sample. Without written approval of Sporton International Inc. (Kunshan), the test report shall not be reproduced except in full.

Jason Jia



Approved by: Jason Jia

Sporton International Inc. (Kunshan)

**No. 1098, Pengxi North Road, Kunshan Economic Development Zone Jiangsu Province 215300
People's Republic of China**



Table of Contents

History of this test report..... 3

Summary of Test Result..... 4

1 General Description 5

 1.1 Applicant..... 5

 1.2 Manufacturer 5

 1.3 Feature of Equipment Under Test..... 5

 1.4 Maximum EIRP Power and Emission Designator 6

 1.5 Specification of Accessory 6

 1.6 Testing Site..... 7

 1.7 Test Software 7

 1.8 Applied Standards 7

2 Test Configuration of Equipment Under Test 8

 2.1 Test Mode..... 8

 2.2 Connection Diagram of Test System 9

 2.3 Support Unit used in test configuration 9

 2.4 Measurement Results Explanation Example 9

 2.5 Frequency List of Low/Middle/High Channels..... 10

3 Conducted Test Items 11

 3.1 Measuring Instruments..... 11

 3.2 Conducted Output Power 12

 3.3 EIRP 13

 3.4 Occupied Bandwidth 14

 3.5 Conducted Band Edge 15

 3.6 Conducted Spurious Emission 16

 3.7 Frequency Stability..... 17

4 Radiated Test Items 18

 4.1 Measuring Instruments..... 18

 4.2 Test Setup 18

 4.3 Test Result of Radiated Test..... 19

 4.4 Radiated Spurious Emission 20

5 List of Measuring Equipment..... 21

6 Measurement Uncertainty 22

Appendix A. Test Results of Conducted Test

Appendix B. Test Results of Radiated Test

Appendix C. Test Setup Photographs



Summary of Test Result

Report Clause	Ref Std. Clause	Test Items	Result (PASS/FAIL)	Remark
3.2	§2.1046	Conducted Output Power	Reporting only	-
-	§96.41	Peak-to-Average Ratio	Not Applicable	Not applicable for End User Devices
3.3	§96.41	Maximum E.I.R.P	Pass	-
		Maximum Power Spectral Density	Not Applicable	Not applicable for End User Devices
3.4	§2.1049 §96.41	Occupied Bandwidth	Reporting only	-
3.5	§2.1051 §96.41	Conducted Band Edge Measurement Adjacent Channel Leakage Ratio	Pass	-
3.6	§2.1051 §96.41	Conducted Spurious Emission	Pass	
3.7	§2.1055	Frequency Stability for Temperature & Voltage	Pass	-
4.4	§2.1051 §96.41	Radiated Spurious Emission	Pass	Under limit 4.42 dB at 7152.00 MHz

Conformity Assessment Condition:
1. The test results (PASS/FAIL) with all measurement uncertainty excluded are presented against the regulation limits or in accordance with the requirements stipulated by the applicant/manufacture who shall bear all the risks of non-compliance that may potentially occur if measurement uncertainty is taken into account.
2. The measurement uncertainty please refer to each test result in the section "Measurement Uncertainty"
Disclaimer:
The product specifications of the EUT presented in the test report that may affect the test assessments are declared by the manufacturer who shall take full responsibility for the authenticity.



1 General Description

1.1 Applicant

Motorola Mobility LLC
222 W,Merchandise Mart Plaza, Chicago IL 60654 USA

1.2 Manufacturer

Motorola Mobility LLC
222 W,Merchandise Mart Plaza, Chicago IL 60654 USA

1.3 Feature of Equipment Under Test

Product Feature	
Equipment	Mobile Cellular Phone
Brand Name	Motorola
Model Name	XT2515-1, XT2515-2, XT2515-3, XT2515V
FCC ID	IHDT56AU5
Tx Frequency	5G NR n48: 3550 MHz ~ 3700 MHz
Rx Frequency	5G NR n48: 3550 MHz ~ 3700 MHz
SCS	30kHz
Bandwidth	10MHz / 15MHz / 20MHz / 30MHz / 40MHz / 50MHz / 60MHz / 70 MHz / 80MHz / 90MHz / 100MHz
Antenna Gain	<Ant. 3> 5G NR n48: -5.5 dBi <Ant. 5> 5G NR n48: -6.1 dBi <Ant. 7> 5G NR n48: -8.3 dBi <Ant. 9> 5G NR n48: -8.5 dBi
Type of Modulation	DFT-s-OFDM (PI/2 BPSK / QPSK / 16QAM / 64QAM / 256QAM) CP-OFDM (QPSK / 16QAM / 64QAM / 256QAM)
IMEI Code	Conducted: 350213730022436/350213730022444 Radiation: 350213730021792/350213730021800
HW Version	DVT2
SW Version	VVE35.35
EUT Stage	Identical Prototype

Remark:

1. There are four models, the four models are for different markets and no other difference.
2. The maximum EIRP is calculated from max output power and max antenna gain, so only the maximum EIRP of Antenna 3 for 5G NR n48 is shown in the report.
3. The maximum conducted power is on antenna 9, so antenna 9 performs the test for all conducted measurement.
4. 5G NR n48 support SA and NSA mode. The whole testing has assessed SA mode by referring to the higher conducted power for conducted test items.
5. The EN-DC mode combination could be referred to the product spec.



1.4 Maximum EIRP Power and Emission Designator

5G NR n48		PI/2 BPSK / QPSK		16QAM/64QAM/256QAM	
BW (MHz)	Frequency Range (MHz)	Maximum EIRP(W)	Emission Designator (99%OBW)	Maximum EIRP(W)	Emission Designator (99%OBW)
10	3555.00~3694.98	0.0547	8M56G7D	0.0439	8M59W7D
15	3557.52~ 3692.49	0.0550	13M5G7D	0.0438	13M6W7D
20	3560.01~3690.00	0.0556	18M2G7D	0.0442	18M2W7D
30	3565.02 ~ 3684.99	0.0555	27M9G7D	0.0444	27M9W7D
40	3570.00~3679.98	0.0557	38M0G7D	0.0446	37M9W7D
50	3575.01 ~ 3675	0.0548	47M6G7D	0.0437	47M6W7D
60	3580.02 ~ 3669.99	0.0545	57M8G7D	0.0433	57M9W7D
70	3585 ~ 3664.98	0.0532	67M3G7D	0.0424	67M6W7D
80	3590.01 ~ 3660	0.0537	77M5G7D	0.0430	77M7W7D
90	3595.02 ~ 3654.99	0.0542	87M5G7D	0.0428	87M5W7D
100	3600 ~ 3649.98	0.0541	97M4G7D	0.0431	97M5W7D

Note: All modulations have been tested, and only the worst test results of PSK & QAM are shown in the report.

1.5 Specification of Accessory

Accessories Information				
AC Adapter 1	Brand Name	Motorola(Aohai)	Model Name	MC-201L
Battery 1	Brand Name	Motorola(NVT)	Model Name	RW50
USB Cable 1	Brand Name	Motorola(Saibao)	Model Name	S928E42856
USB Cable 2	Brand Name	Motorola(Naiyi)	Model Name	S928E42857
USB Cable 3	Brand Name	Motorola(Saibao)	Model Name	S928E44701
USB Cable 4	Brand Name	Motorola(Naiyi)	Model Name	S928E44702



1.6 Testing Site

Sporton International Inc. (Kunshan) is accredited to ISO/IEC 17025:2017 by American Association for Laboratory Accreditation with Certificate Number 5145.02.

Test Firm	Sporton International Inc. (Kunshan)		
Test Site Location	No. 1098, Pengxi North Road, Kunshan Economic Development Zone Jiangsu Province 215300 People's Republic of China TEL : +86-512-57900158		
Test Site No.	Sporton Site No.	FCC Designation No.	FCC Test Firm Registration No.
	03CH04-KS TH01-KS	CN1257	314309

1.7 Test Software

Item	Site	Manufacturer	Name	Version
1.	TH01-KS	SPORTON	Part2224_Ver5.0 200330	5.0
2.	03CH04-KS	AUDIX	E3	210616

1.8 Applied Standards

According to the specifications of the manufacturer, the EUT must comply with the requirements of the following standards:

- ♦ ANSI C63.26-2015
- ♦ 47 CFR Part 96
- ♦ FCC KDB 971168 D01 Power Meas. License Digital Systems v03r01
- ♦ FCC KDB 940660 D01 Part 96 CBRS v03
- ♦ FCC KDB 412172 D01 Determining ERP and EIRP v01r01

Remark:

1. All test items were verified and recorded according to the standards and without any deviation during the test.
2. This EUT has also been tested and complied with the requirements of FCC Part 15, Subpart B, recorded in a separate test report.



2 Test Configuration of Equipment Under Test

2.1 Test Mode

Antenna port conducted and radiated test items listed below are performed according to KDB 971168 D01 Power Meas. License Digital Systems v03r01 with maximum output power.

For radiated measurement, pre-scanned in three orthogonal panels, X, Y, Z. The worst cases (Y plane) were recorded in this report.

Test Items	Band	Bandwidth (MHz)							Modulation					RB #		Test Channel		
		10	15	20	30-40	50	60-90	100	PI/2 BPSK	QPSK	16QAM	64QAM	256 QAM	1	Full	L	M	H
Max. Output Power	n48	v	v	v	v	v	v	v	v	v	v	v	v	v	v	v	v	v
26dB and 99% Bandwidth	n48	v	v	v	v	v	v	v		v	v	v	v		v	v	v	
Adjacent Channel Leakage Ratio	n48	v	v	v	v	v	v	v	v	v				v	v		v	
Conducted Band Edge	n48	v	v	v	v	v	v	v	v	v				v	v	v	v	
Conducted Spurious Emission	n48	v	v	v	v	v	v	v	v	v				v		v	v	
E.I.R.P	n48	v	v	v	v	v	v	v	v	v	v	v	v	v	v	v	v	
Frequency Stability	n48			v						v				v		v		
Radiated Spurious Emission	n48	Worst Case														v	v	v
Remark	<ol style="list-style-type: none"> The mark "v " means that this configuration is chosen for testing The mark "- " means that this bandwidth is not supported. The device is investigated from 30MHz to 10 times of fundamental signal for radiated spurious emission test under different RB size/offset and modulations in exploratory test. Subsequently, only the worst case emissions are reported. All test items are based on engineering evaluation. Frequency Stability : Normal Voltage = 3.8V ; Low Voltage =3.6V. ; High Voltage =4.2V. 																	

2.2 Connection Diagram of Test System

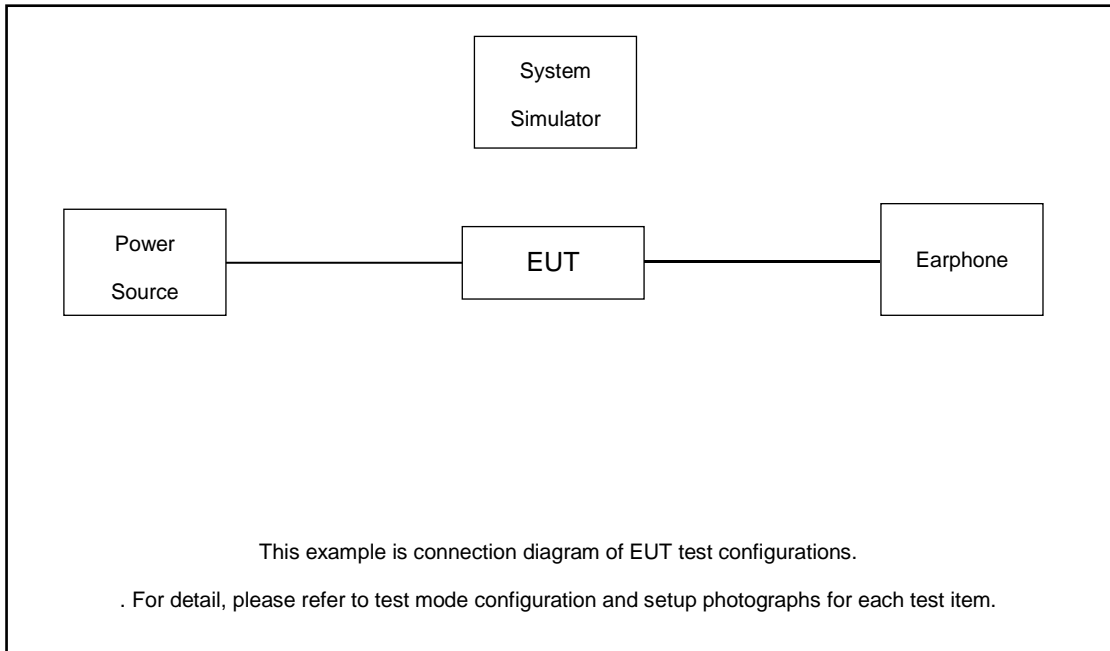

2.3 Support Unit used in test configuration

Item	Equipment	Trade Name	Model No.	FCC ID	Data Cable	Power Cord
1.	Power Supply	GWINSTEK	PSS-2002	N/A	N/A	Unshielded, 1.8 m
2.	LTE Base Station	Anritsu	MT8820C	N/A	N/A	Unshielded, 1.8 m
3.	NR Base Station	Anritsu	MT8000A	N/A	N/A	Unshielded, 1.8 m
4.	Earphone	N/A	N/A	N/A	N/A	N/A

2.4 Measurement Results Explanation Example

For all conducted test items:

The offset level is set in the spectrum analyzer to compensate the RF cable loss and attenuator factor between EUT conducted output port and spectrum analyzer. With the offset compensation, the spectrum analyzer reading level is exactly the EUT RF output level.

The spectrum analyzer offset is derived from RF cable loss and attenuator factor.

$$\text{Offset} = \text{RF cable loss} + \text{attenuator factor}.$$

Following shows an offset computation example with cable loss 3.43 dB and 20dB attenuator.

Example :

$$\begin{aligned} \text{Offset(dB)} &= \text{RF cable loss(dB)} + \text{attenuator factor(dB)}. \\ &= 3.43 + 20 = 23.43 \text{ (dB)} \end{aligned}$$



2.5 Frequency List of Low/Middle/High Channels

5G NR n48 Channel and Frequency List				
BW [MHz]	Channel/Frequency(MHz)	Lowest	Middle	Highest
100	Channel	640000	641666	643332
	Frequency	3600	3624.99	3649.98
90	Channel	639668	641666	643666
	Frequency	3595.02	3624.99	3654.99
80	Channel	639334	641666	644000
	Frequency	3590.01	3624.99	3660
70	Channel	639000	641666	644332
	Frequency	3585	3624.99	3664.98
60	Channel	638668	641666	644666
	Frequency	3580.02	3624.99	3669.99
50	Channel	638334	645000	645000
	Frequency	3575.01	3624.99	3675
40	Channel	638000	641666	645332
	Frequency	3570	3624.99	3679.98
30	Channel	637668	641666	645666
	Frequency	3565.02	3624.99	3684.99
20	Channel	637334	641666	646000
	Frequency	3560.01	3624.99	3690
15	Channel	637168	641666	646166
	Frequency	3557.52	3624.99	3692.49
10	Channel	637000	641666	646332
	Frequency	3555	3624.99	3694.98

3 Conducted Test Items

3.1 Measuring Instruments

See list of measuring instruments of this test report.

3.1.1 Test Setup

3.1.2 Conducted Output Power / ACLR

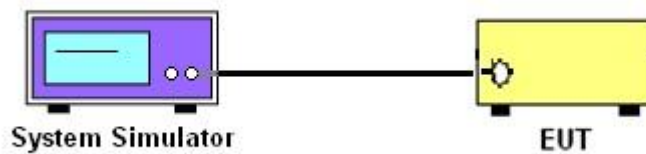

3.1.3 Occupied Bandwidth, Conducted Band-Edge and Conducted Spurious Emission

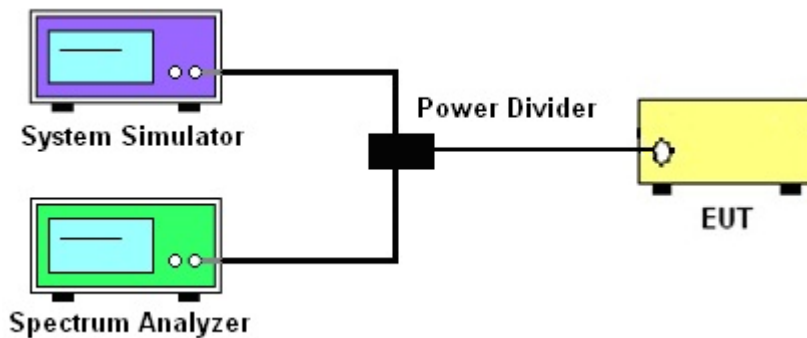

3.1.4 Frequency Stability

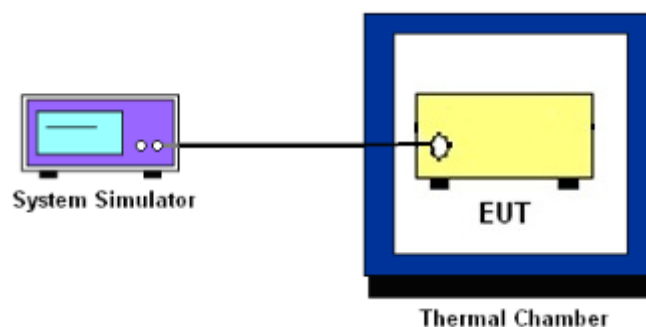

3.1.5 Test Result of Conducted Test

Please refer to Appendix A.



3.2 Conducted Output Power

3.2.1 Description of the Conducted Output Power Measurement

A system simulator was used to establish communication with the EUT. Its parameters were set to force the EUT transmitting at maximum output power. The measured power in the radio frequency on the transmitter output terminals shall be reported.

3.2.2 Test Procedures

1. The transmitter output port was connected to the system simulator.
2. Set EUT at maximum power through the system simulator.
3. Select lowest, middle, and highest channels for each band and different modulation.
4. Measure and record the power level from the system simulator.

3.3 EIRP

3.3.1 Description of the EIRP Measurement

EIRP limits for CBRS equipment as below table:

Device		Maximum EIRP (dBm/10 MHz)	Maximum PSD (dBm/MHz)
Applied	End User Device	23	n/a
<input type="checkbox"/>	Category A CBSD	30	20
<input type="checkbox"/>	Category B CBSD	47	37

Remark:

1. The worst case EIRP shown in this section is found with NR operating only using 1RB. As such, the EIRP/10MHz and full channel EIRP values will be identical since 1RB is fully contained within all available channel bandwidths for n48 (i.e. 10, 15, 20, 30MHz)

3.3.2 Test Procedures for EIRP

1. Establishing a communications link with the call box (Base station) to measure the Maximum conducted power, the parameters were set to force the EUT transmitting at maximum output power level. Use the average power measurement function to measure total channel power of each channel bandwidth (per ANSI C63.26-2015 Section 5.2.1)
2. Determining ERP and/or EIRP from conducted RF output power measurements (Per ANSI C63.26-2015 Section 5.2.5.5)

$EIRP = P_T + G_T - L_C$, $ERP = EIRP - 2.15$, where
 P_T = transmitter output power in dBm
 G_T = gain of the transmitting antenna in dBi
 L_C = signal attenuation in the connecting cable between the transmitter and antenna in dB



3.4 Occupied Bandwidth

3.4.1 Description of Occupied Bandwidth Measurement

The occupied bandwidth is the width of a frequency band such that, below the lower and above the upper frequency limits, the mean powers emitted are each equal to a specified percentage 0.5% of the total mean transmitted power.

The 26 dB emission bandwidth is defined as the frequency range between two points, one above and one below the carrier frequency, at which the spectral density of the emission is attenuated 26 dB below the maximum in-band spectral density of the modulated signal. Spectral density (power per unit bandwidth) is to be measured with a detector of resolution bandwidth equal to approximately 1.0% of the emission bandwidth.

3.4.2 Test Procedures

The testing follows ANSI C63.26-2015 Section 5.4.3 (26dB) and Section 5.4.4 (99OB)

1. The EUT was connected to spectrum analyzer and system simulator via a power divider.
2. The spectrum analyzer center frequency is set to the nominal EUT channel center frequency. The span range for the spectrum analyzer shall be between two and five times the anticipated OBW.
3. The nominal resolution bandwidth (RBW) shall be in the range of 1 to 5 % of the anticipated OBW, and the VBW shall be at least 3 times the RBW.
4. Set the detection mode to peak, and the trace mode to max hold.
5. Determine the reference value: Set the EUT to transmit a modulated signal. Allow the trace to stabilize. Set the spectrum analyzer marker to the highest level of the displayed trace.
(this is the reference value)
6. Determine the “-26 dB down amplitude” as equal to (Reference Value – X).
7. Place two markers, one at the lowest and the other at the highest frequency of the envelope of the spectral display such that each marker is at or slightly below the “-X dB down amplitude” determined in step 6. If a marker is below this “-X dB down amplitude” value it shall be placed as close as possible to this value. The OBW is the positive frequency difference between the two markers.
8. Use the 99 % power bandwidth function of the spectrum analyzer and report the measured bandwidth.

3.5 Conducted Band Edge

3.5.1 Description of Conducted Band Edge Measurement

Part 96.41 (e) (1) (i)

For CBSD the emission limits outside the fundamental are as follows:

Within 0 MHz to 10 MHz above and below the assigned channel ≤ -13 dBm/MHz

Greater than 10 MHz above and below the assigned channel ≤ -25 dBm/MHz

Part 96.41 (e) (1) (ii)

For End User Devices the emission limits outside the fundamental are as follows:

Within 0 MHz to B MHz above and below the assigned channel ≤ -13 dBm/MHz

Greater than B MHz above and below the assigned channel ≤ -25 dBm/MHz

where B is the bandwidth in megahertz of the assigned channel or multiple contiguous channels of the End User Device.

Notwithstanding the emission limits in this paragraph, the Adjacent Channel Leakage Ratio for End User Devices shall be at least 30 dB.

Part 96.41 (e) (2)

For CBSDs and End User Devices, the conducted power of emissions below 3540 MHz or above 3710 MHz shall not exceed -25 dBm/MHz, and the conducted power of emissions below 3530 MHz or above 3720 MHz shall not exceed -40 dBm/MHz

3.5.2 Test Procedures

The testing follows FCC KDB 971168 D01 v03r01 Section 6.1.

1. The EUT was connected to spectrum analyzer and system simulator via a power divider.
2. The band edges of low and high channels for the highest RF powers were measured.
3. Set RBW $\geq 1\%$ EBW in the 1MHz band immediately outside and adjacent to the band edge.
4. Beyond the 1 MHz band from the band edge, RBW=1MHz was used or a narrower RBW was used (generally limited to no less than 1% of the OBW) and the measured power was integrated over the full required measurement bandwidth.
5. Offset has included the duty factor for LTE Band 48. Duty factor $=10 \log (1/x)$, where x is the measured duty cycle.
6. Set spectrum analyzer with RMS detector.
7. The RF fundamental frequency should be excluded against the limit line in the operating frequency band.



3.6 Conducted Spurious Emission

3.6.1 Description of Conducted Spurious Emission Measurement

96.41 (e)(2)

The conducted power of any emissions below 3530 MHz or above 3720 MHz shall not exceed -40dBm/MHz.

3.6.2 Test Procedures

The testing follows FCC KDB 971168 D01 v03r01 Section 6.1.

1. The EUT was connected to spectrum analyzer and system simulator via a power divider.
2. The RF output of EUT was connected to the spectrum analyzer by RF cable and attenuator. The path loss was compensated to the results for each measurement.
3. The middle channel for the highest RF power within the transmitting frequency was measured.
4. The conducted spurious emission for the whole frequency range was taken.
5. Make the measurement with the spectrum analyzer's RBW = 1MHz, VBW = 3MHz.
6. Set spectrum analyzer with RMS detector.
7. Taking the record of maximum spurious emission.
8. The RF fundamental frequency should be excluded against the limit line in the operating frequency band.
9. The limit line is -40dBm/MHz.



3.7 Frequency Stability

3.7.1 Description of Frequency Stability Measurement

The frequency stability shall be measured by variation of ambient temperature and variation of primary supply voltage to ensure that the fundamental emission stays within the authorized frequency block.

3.7.2 Test Procedures for Temperature Variation

The testing follows FCC KDB 971168 D01 v03r01 Section 9.0.

1. The EUT was set up in the thermal chamber and connected with the system simulator.
2. With power OFF, the temperature was decreased to -30°C and the EUT was stabilized before testing. Power was applied and the maximum change in frequency was recorded within one minute.
3. With power OFF, the temperature was raised in 10°C step up to 50°C . The EUT was stabilized at each step for at least half an hour. Power was applied and the maximum frequency change was recorded within one minute.

3.7.3 Test Procedures for Voltage Variation

The testing follows FCC KDB 971168 D01 v03r01 Section 9.0.

1. The EUT was placed in a temperature chamber at $25\pm 5^{\circ}\text{C}$ and connected with the system simulator.
2. The power supply voltage to the EUT was varied from 85% to 115% of the nominal value measured at the input to the EUT.
3. The variation in frequency was measured for the worst case.

4 Radiated Test Items

4.1 Measuring Instruments

See list of measuring instruments of this test report.

4.2 Test Setup

4.2.1 For radiated test below 30MHz

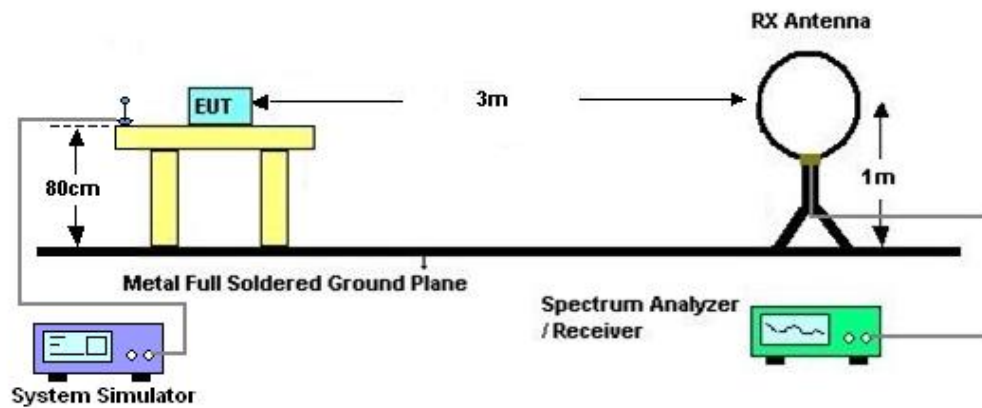

4.2.2 For radiated test from 30MHz to 1GHz

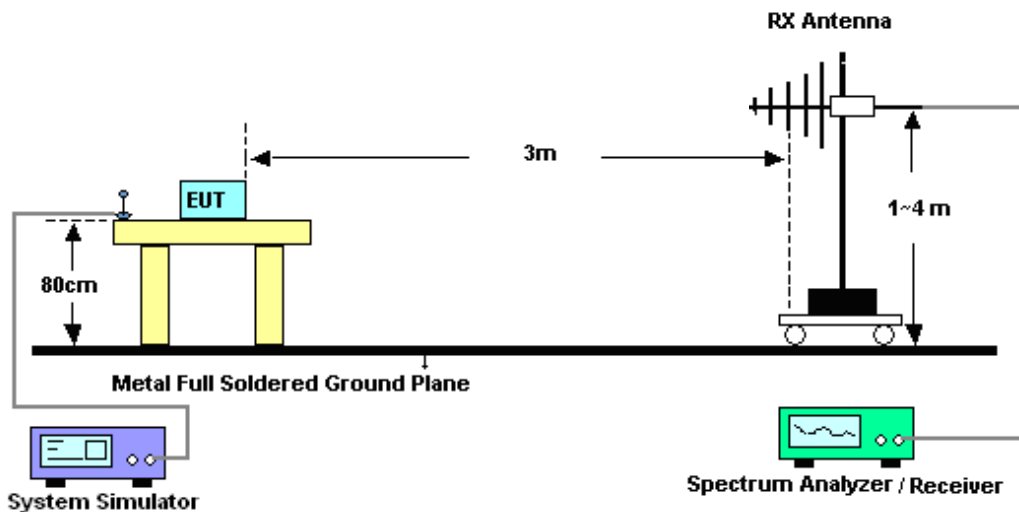

4.2.3 For radiated test above 1GHz

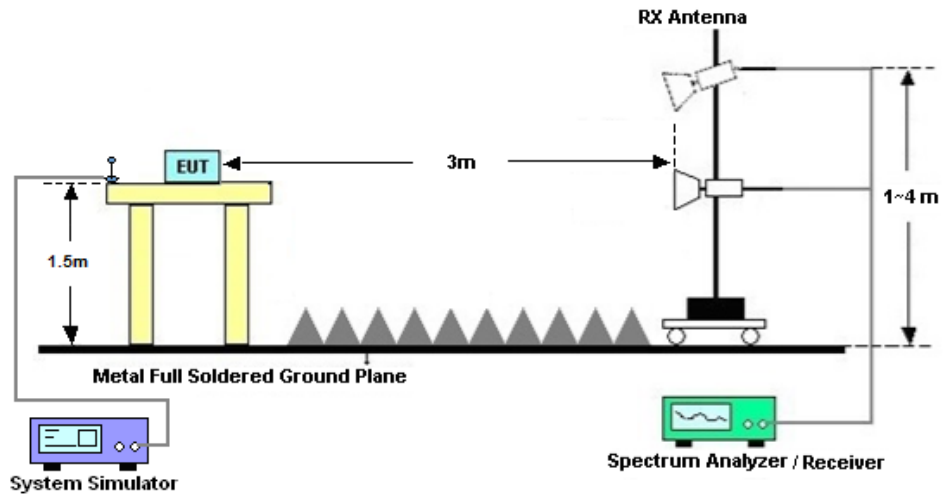

4.3 Test Result of Radiated Test

The low frequency, which started from 9 kHz to 30MHz, was pre-scanned and the result which was 20dB lower than the limit line was not reported.

Please refer to Appendix B.



4.4 Radiated Spurious Emission

4.4.1 Description of Radiated Spurious Emission Measurement

The radiated spurious emission was measured by substitution method according to ANSI C63.26. The power of any emission outside of the authorized operating frequency ranges must be attenuated below the transmitter power (P) by a factor of at least -40dBm / MHz.

The spectrum is scanned from 30 MHz up to a frequency including its 10th harmonic.

4.4.2 Test Procedures

1. The EUT was placed on a turntable with 0.8 meter height for frequency below 1GHz and 1.5 meter height for frequency above 1GHz respectively above ground.
2. The EUT was set 3 meters from the receiving antenna mounted on the antenna tower.
3. The table was rotated 360 degrees to determine the position of the highest spurious emission.
4. The height of the receiving antenna is varied between 1m to 4m to search the maximum spurious emission for both horizontal and vertical polarizations.
5. During the measurement, the system simulator parameters were set to force the EUT transmitting at maximum output power.
6. Make the measurement with the spectrum analyzer's RBW = 1MHz, VBW = 3MHz, taking the record of maximum spurious emission.
7. A horn antenna was substituted in place of the EUT and was driven by a signal generator. Tune the output power of signal generator to the same emission level with EUT maximum spurious emission.
EIRP (dBm) = S.G. Power – Tx Cable Loss + Tx Antenna Gain
ERP (dBm) = EIRP - 2.15
8. The RF fundamental frequency should be excluded against the limit line in the operating frequency band.

The limit line is -40dBm/MHz



5 List of Measuring Equipment

Instrument	Manufacturer	Model No.	Serial No.	Characteristics	Calibration Date	Test Date	Due Date	Remark
Spectrum Analyzer	R&S	FSV40	101040	10Hz~40GHz	Oct. 11, 2023	Sep. 24, 2024~ Oct. 06, 2024	Oct. 10, 2024	Conducted (TH01-KS)
Power divider	STI	STI08-0055	-	0.5~40GHz	NCR	Sep. 24, 2024~ Oct. 06, 2024	NCR	Conducted (TH01-KS)
Temperature & humidity	Hongzhan	LP-150U	H2014011440	-40~+150°C 20%~95%RH	Jul. 04, 2024	Sep. 24, 2024~ Oct. 06, 2024	Jul. 03, 2025	Conducted (TH01-KS)
EXA Spectrum Analyzer	Keysight	N9010B	MY57471079	10Hz~44G,MAX 30dB	Oct. 11, 2023	Oct. 08, 2024	Oct. 10, 2024	Radiation (03CH04-KS)
Loop Antenna	R&S	HFH2-Z2E	101125	9kHz~30MHz	Sep. 08, 2024	Oct. 08, 2024	Sep. 07, 2025	Radiation (03CH04-KS)
Bilog Antenna	TeseQ	CBL6111D	44483	30MHz-1GHz	Dec. 06, 2023	Oct. 08, 2024	Dec. 05, 2024	Radiation (03CH04-KS)
Double Ridge Horn Antenna	ETS-Lindgren	3117	75957	1GHz~18GHz	Oct. 23, 2023	Oct. 08, 2024	Oct. 22, 2024	Radiation (03CH04-KS)
SHF-EHF Horn	Com-power	AH-840	101070	18GHz~40GHz	Jan. 27, 2024	Oct. 08, 2024	Jan. 26, 2025	Radiation (03CH04-KS)
Amplifier	SONOMA	310N	413740	9KHz-1GHz	Jan. 03, 2024	Oct. 08, 2024	Jan. 02, 2025	Radiation (03CH04-KS)
Amplifier	EM	EM18G40G A	060728	18~40GHz	Jan. 02, 2024	Oct. 08, 2024	Jan. 01, 2025	Radiation (03CH04-KS)
high gain Amplifier	EM	EM01G18G A	060840	1Ghz-18Ghz	Oct. 11, 2023	Oct. 08, 2024	Oct. 10, 2024	Radiation (03CH04-KS)
Amplifier	EM	EM01G18G A	060892	1Ghz-18Ghz	Oct. 11, 2023	Oct. 08, 2024	Oct. 10, 2024	Radiation (03CH04-KS)
AC Power Source	Chroma	61601	F104090004	N/A	NCR	Oct. 08, 2024	NCR	Radiation (03CH04-KS)
Turn Table	ChamPro	EM 1000-T	060762-T	0~360 degree	NCR	Oct. 08, 2024	NCR	Radiation (03CH04-KS)
Antenna Mast	ChamPro	EM 1000-A	060762-A	1 m~4 m	NCR	Oct. 08, 2024	NCR	Radiation (03CH04-KS)

NCR: No Calibration Required



6 Measurement Uncertainty

Uncertainty of Conducted Measurement

Conducted Spurious Emission & Bandedge	±2.22 dB
Occupied Channel Bandwidth	±0.1%
Conducted Power	±0.50 dB
Peak to Average Ratio	±0.50 dB
Frequency Stability	±0.04 Hz

Uncertainty of Radiated Emission Measurement (30 MHz ~ 1000 MHz)

Measuring Uncertainty for a Level of Confidence of 95% (U = 2Uc(y))	2.83 dB
---------------------------------------------------------------------	---------

Uncertainty of Radiated Emission Measurement (1 GHz ~ 18 GHz)

Measuring Uncertainty for a Level of Confidence of 95% (U = 2Uc(y))	2.83 dB
---------------------------------------------------------------------	---------

Uncertainty of Radiated Emission Measurement (18 GHz ~ 40 GHz)

Measuring Uncertainty for a Level of Confidence of 95% (U = 2Uc(y))	2.82 dB
---------------------------------------------------------------------	---------

----- THE END -----



Appendix A. Test Results of Conducted Test

Test Engineer :	Smile	Temperature :	22~23°C
		Relative Humidity :	40~42%



Software Version: 23.06.1602

FR1 N48

For Ant3:

Transmitter Conducted Output Power And EIRP, (G_T - L_C)=-5.5dB

NR Band	SCS	BandWidth	Arfcn	Freq (MHz)	Modulation	RB	Conducted Power(dBm)	EIRP (dBm)	EIRP (W)
48	30	10	637000	3555	DFT-s-OFDM PI/2 BPSK	12@6	22.33	16.83	0.0482
48	30	10	637000	3555	DFT-s-OFDM PI/2 BPSK	1@1	22.40	16.90	0.0490
48	30	10	637000	3555	DFT-s-OFDM PI/2 BPSK	1@22	22.42	16.92	0.0492
48	30	10	637000	3555	DFT-s-OFDM QPSK	12@6	22.50	17.00	0.0501
48	30	10	637000	3555	DFT-s-OFDM QPSK	1@1	22.33	16.83	0.0482
48	30	10	637000	3555	DFT-s-OFDM QPSK	1@22	22.40	16.90	0.0490
48	30	10	637000	3555	DFT-s-OFDM 16 QAM	12@6	21.46	15.96	0.0394
48	30	10	637000	3555	DFT-s-OFDM 16 QAM	1@1	21.43	15.93	0.0392
48	30	10	637000	3555	DFT-s-OFDM 16 QAM	1@22	21.51	16.01	0.0399
48	30	10	637000	3555	DFT-s-OFDM 64 QAM	12@6	19.92	14.42	0.0277
48	30	10	637000	3555	DFT-s-OFDM 64 QAM	1@1	19.87	14.37	0.0274
48	30	10	637000	3555	DFT-s-OFDM 64 QAM	1@22	19.90	14.40	0.0275
48	30	10	637000	3555	DFT-s-OFDM 256 QAM	12@6	18.09	12.59	0.0182
48	30	10	637000	3555	DFT-s-OFDM 256 QAM	1@1	17.76	12.26	0.0168
48	30	10	637000	3555	DFT-s-OFDM 256 QAM	1@22	17.78	12.28	0.0169
48	30	10	637000	3555	CP-OFDM QPSK	12@6	20.79	15.29	0.0338
48	30	10	637000	3555	CP-OFDM QPSK	1@1	20.95	15.45	0.0351
48	30	10	637000	3555	CP-OFDM QPSK	1@22	20.93	15.43	0.0349
48	30	10	641666	3624.99	DFT-s-OFDM PI/2 BPSK	12@6	22.83	17.33	0.0541
48	30	10	641666	3624.99	DFT-s-OFDM PI/2 BPSK	1@1	22.73	17.23	0.0528
48	30	10	641666	3624.99	DFT-s-OFDM PI/2 BPSK	1@22	22.82	17.32	0.0540
48	30	10	641666	3624.99	DFT-s-OFDM QPSK	12@6	22.81	17.31	0.0538
48	30	10	641666	3624.99	DFT-s-OFDM QPSK	1@1	22.72	17.22	0.0527
48	30	10	641666	3624.99	DFT-s-OFDM QPSK	1@22	22.88	17.38	0.0547
48	30	10	641666	3624.99	DFT-s-OFDM 16 QAM	12@6	21.92	16.42	0.0439
48	30	10	641666	3624.99	DFT-s-OFDM 16 QAM	1@1	21.74	16.24	0.0421
48	30	10	641666	3624.99	DFT-s-OFDM 16 QAM	1@22	21.83	16.33	0.0430
48	30	10	641666	3624.99	DFT-s-OFDM 64 QAM	12@6	20.21	14.71	0.0296
48	30	10	641666	3624.99	DFT-s-OFDM 64 QAM	1@1	20.12	14.62	0.0290
48	30	10	641666	3624.99	DFT-s-OFDM 64 QAM	1@22	20.32	14.82	0.0303
48	30	10	641666	3624.99	DFT-s-OFDM 256 QAM	12@6	18.54	13.04	0.0201
48	30	10	641666	3624.99	DFT-s-OFDM 256 QAM	1@1	18.14	12.64	0.0184
48	30	10	641666	3624.99	DFT-s-OFDM 256 QAM	1@22	18.31	12.81	0.0191
48	30	10	641666	3624.99	CP-OFDM QPSK	12@6	21.18	15.68	0.0370
48	30	10	641666	3624.99	CP-OFDM QPSK	1@1	21.31	15.81	0.0381



48	30	10	641666	3624.99	CP-OFDM QPSK	1@22	21.50	16.00	0.0398
48	30	10	646332	3694.98	DFT-s-OFDM PI/2 BPSK	12@6	22.59	17.09	0.0512
48	30	10	646332	3694.98	DFT-s-OFDM PI/2 BPSK	1@1	22.47	16.97	0.0498
48	30	10	646332	3694.98	DFT-s-OFDM PI/2 BPSK	1@22	22.44	16.94	0.0494
48	30	10	646332	3694.98	DFT-s-OFDM QPSK	12@6	22.58	17.08	0.0511
48	30	10	646332	3694.98	DFT-s-OFDM QPSK	1@1	22.48	16.98	0.0499
48	30	10	646332	3694.98	DFT-s-OFDM QPSK	1@22	22.41	16.91	0.0491
48	30	10	646332	3694.98	DFT-s-OFDM 16 QAM	12@6	21.58	16.08	0.0406
48	30	10	646332	3694.98	DFT-s-OFDM 16 QAM	1@1	21.50	16.00	0.0398
48	30	10	646332	3694.98	DFT-s-OFDM 16 QAM	1@22	21.54	16.04	0.0402
48	30	10	646332	3694.98	DFT-s-OFDM 64 QAM	12@6	20.10	14.60	0.0288
48	30	10	646332	3694.98	DFT-s-OFDM 64 QAM	1@1	19.97	14.47	0.0280
48	30	10	646332	3694.98	DFT-s-OFDM 64 QAM	1@22	19.87	14.37	0.0274
48	30	10	646332	3694.98	DFT-s-OFDM 256 QAM	12@6	18.18	12.68	0.0185
48	30	10	646332	3694.98	DFT-s-OFDM 256 QAM	1@1	17.81	12.31	0.0170
48	30	10	646332	3694.98	DFT-s-OFDM 256 QAM	1@22	17.86	12.36	0.0172
48	30	10	646332	3694.98	CP-OFDM QPSK	12@6	20.86	15.36	0.0344
48	30	10	646332	3694.98	CP-OFDM QPSK	1@1	20.92	15.42	0.0348
48	30	10	646332	3694.98	CP-OFDM QPSK	1@22	20.89	15.39	0.0346
48	30	15	637168	3557.52	DFT-s-OFDM PI/2 BPSK	18@9	22.53	17.03	0.0505
48	30	15	637168	3557.52	DFT-s-OFDM PI/2 BPSK	1@1	22.44	16.94	0.0494
48	30	15	637168	3557.52	DFT-s-OFDM PI/2 BPSK	1@36	22.51	17.01	0.0502
48	30	15	637168	3557.52	DFT-s-OFDM QPSK	18@9	22.58	17.08	0.0511
48	30	15	637168	3557.52	DFT-s-OFDM QPSK	1@1	22.46	16.96	0.0497
48	30	15	637168	3557.52	DFT-s-OFDM QPSK	1@36	22.52	17.02	0.0504
48	30	15	637168	3557.52	DFT-s-OFDM 16 QAM	18@9	21.56	16.06	0.0404
48	30	15	637168	3557.52	DFT-s-OFDM 16 QAM	1@1	21.48	15.98	0.0396
48	30	15	637168	3557.52	DFT-s-OFDM 16 QAM	1@36	21.54	16.04	0.0402
48	30	15	637168	3557.52	DFT-s-OFDM 64 QAM	18@9	20.17	14.67	0.0293
48	30	15	637168	3557.52	DFT-s-OFDM 64 QAM	1@1	20.02	14.52	0.0283
48	30	15	637168	3557.52	DFT-s-OFDM 64 QAM	1@36	19.89	14.39	0.0275
48	30	15	637168	3557.52	DFT-s-OFDM 256 QAM	18@9	18.04	12.54	0.0179
48	30	15	637168	3557.52	DFT-s-OFDM 256 QAM	1@1	17.86	12.36	0.0172
48	30	15	637168	3557.52	DFT-s-OFDM 256 QAM	1@36	17.91	12.41	0.0174
48	30	15	637168	3557.52	CP-OFDM QPSK	19@9	21.05	15.55	0.0359
48	30	15	637168	3557.52	CP-OFDM QPSK	1@1	21.12	15.62	0.0365
48	30	15	637168	3557.52	CP-OFDM QPSK	1@36	21.08	15.58	0.0361
48	30	15	641666	3624.99	DFT-s-OFDM PI/2 BPSK	18@9	22.84	17.34	0.0542
48	30	15	641666	3624.99	DFT-s-OFDM PI/2 BPSK	1@1	22.71	17.21	0.0526
48	30	15	641666	3624.99	DFT-s-OFDM PI/2 BPSK	1@36	22.90	17.40	0.0550
48	30	15	641666	3624.99	DFT-s-OFDM QPSK	18@9	22.86	17.36	0.0545
48	30	15	641666	3624.99	DFT-s-OFDM QPSK	1@1	22.74	17.24	0.0530



48	30	15	641666	3624.99	DFT-s-OFDM QPSK	1@36	22.89	17.39	0.0548
48	30	15	641666	3624.99	DFT-s-OFDM 16 QAM	18@9	21.88	16.38	0.0435
48	30	15	641666	3624.99	DFT-s-OFDM 16 QAM	1@1	21.70	16.20	0.0417
48	30	15	641666	3624.99	DFT-s-OFDM 16 QAM	1@36	21.91	16.41	0.0438
48	30	15	641666	3624.99	DFT-s-OFDM 64 QAM	18@9	20.53	15.03	0.0318
48	30	15	641666	3624.99	DFT-s-OFDM 64 QAM	1@1	20.20	14.70	0.0295
48	30	15	641666	3624.99	DFT-s-OFDM 64 QAM	1@36	20.44	14.94	0.0312
48	30	15	641666	3624.99	DFT-s-OFDM 256 QAM	18@9	18.45	12.95	0.0197
48	30	15	641666	3624.99	DFT-s-OFDM 256 QAM	1@1	18.14	12.64	0.0184
48	30	15	641666	3624.99	DFT-s-OFDM 256 QAM	1@36	18.36	12.86	0.0193
48	30	15	641666	3624.99	CP-OFDM QPSK	19@9	21.35	15.85	0.0385
48	30	15	641666	3624.99	CP-OFDM QPSK	1@1	21.44	15.94	0.0393
48	30	15	641666	3624.99	CP-OFDM QPSK	1@36	21.47	15.97	0.0395
48	30	15	646166	3692.49	DFT-s-OFDM PI/2 BPSK	18@9	22.50	17.00	0.0501
48	30	15	646166	3692.49	DFT-s-OFDM PI/2 BPSK	1@1	22.47	16.97	0.0498
48	30	15	646166	3692.49	DFT-s-OFDM PI/2 BPSK	1@36	22.43	16.93	0.0493
48	30	15	646166	3692.49	DFT-s-OFDM QPSK	18@9	22.57	17.07	0.0509
48	30	15	646166	3692.49	DFT-s-OFDM QPSK	1@1	22.50	17.00	0.0501
48	30	15	646166	3692.49	DFT-s-OFDM QPSK	1@36	22.54	17.04	0.0506
48	30	15	646166	3692.49	DFT-s-OFDM 16 QAM	18@9	21.58	16.08	0.0406
48	30	15	646166	3692.49	DFT-s-OFDM 16 QAM	1@1	21.51	16.01	0.0399
48	30	15	646166	3692.49	DFT-s-OFDM 16 QAM	1@36	21.49	15.99	0.0397
48	30	15	646166	3692.49	DFT-s-OFDM 64 QAM	18@9	20.13	14.63	0.0290
48	30	15	646166	3692.49	DFT-s-OFDM 64 QAM	1@1	20.03	14.53	0.0284
48	30	15	646166	3692.49	DFT-s-OFDM 64 QAM	1@36	19.91	14.41	0.0276
48	30	15	646166	3692.49	DFT-s-OFDM 256 QAM	18@9	18.10	12.60	0.0182
48	30	15	646166	3692.49	DFT-s-OFDM 256 QAM	1@1	17.86	12.36	0.0172
48	30	15	646166	3692.49	DFT-s-OFDM 256 QAM	1@36	17.95	12.45	0.0176
48	30	15	646166	3692.49	CP-OFDM QPSK	19@9	21.09	15.59	0.0362
48	30	15	646166	3692.49	CP-OFDM QPSK	1@1	20.89	15.39	0.0346
48	30	15	646166	3692.49	CP-OFDM QPSK	1@36	21.06	15.56	0.0360
48	30	20	637334	3560.01	DFT-s-OFDM PI/2 BPSK	25@12	22.47	16.97	0.0498
48	30	20	637334	3560.01	DFT-s-OFDM PI/2 BPSK	1@1	22.47	16.97	0.0498
48	30	20	637334	3560.01	DFT-s-OFDM PI/2 BPSK	1@49	22.51	17.01	0.0502
48	30	20	637334	3560.01	DFT-s-OFDM QPSK	25@12	22.62	17.12	0.0515
48	30	20	637334	3560.01	DFT-s-OFDM QPSK	1@1	22.52	17.02	0.0504
48	30	20	637334	3560.01	DFT-s-OFDM QPSK	1@49	22.54	17.04	0.0506
48	30	20	637334	3560.01	DFT-s-OFDM 16 QAM	25@12	21.60	16.10	0.0407
48	30	20	637334	3560.01	DFT-s-OFDM 16 QAM	1@1	21.52	16.02	0.0400
48	30	20	637334	3560.01	DFT-s-OFDM 16 QAM	1@49	21.67	16.17	0.0414
48	30	20	637334	3560.01	DFT-s-OFDM 64 QAM	25@12	20.07	14.57	0.0286
48	30	20	637334	3560.01	DFT-s-OFDM 64 QAM	1@1	20.02	14.52	0.0283



48	30	20	637334	3560.01	DFT-s-OFDM 64 QAM	1@49	20.16	14.66	0.0292
48	30	20	637334	3560.01	DFT-s-OFDM 256 QAM	25@12	18.09	12.59	0.0182
48	30	20	637334	3560.01	DFT-s-OFDM 256 QAM	1@1	17.90	12.40	0.0174
48	30	20	637334	3560.01	DFT-s-OFDM 256 QAM	1@49	17.94	12.44	0.0175
48	30	20	637334	3560.01	CP-OFDM QPSK	25@12	21.08	15.58	0.0361
48	30	20	637334	3560.01	CP-OFDM QPSK	1@1	21.03	15.53	0.0357
48	30	20	637334	3560.01	CP-OFDM QPSK	1@49	21.08	15.58	0.0361
48	30	20	641666	3624.99	DFT-s-OFDM PI/2 BPSK	25@12	22.86	17.36	0.0545
48	30	20	641666	3624.99	DFT-s-OFDM PI/2 BPSK	1@1	22.66	17.16	0.0520
48	30	20	641666	3624.99	DFT-s-OFDM PI/2 BPSK	1@49	22.95	17.45	0.0556
48	30	20	641666	3624.99	DFT-s-OFDM QPSK	25@12	22.89	17.39	0.0548
48	30	20	641666	3624.99	DFT-s-OFDM QPSK	1@1	22.70	17.20	0.0525
48	30	20	641666	3624.99	DFT-s-OFDM QPSK	1@49	22.91	17.41	0.0551
48	30	20	641666	3624.99	DFT-s-OFDM 16 QAM	25@12	21.95	16.45	0.0442
48	30	20	641666	3624.99	DFT-s-OFDM 16 QAM	1@1	21.75	16.25	0.0422
48	30	20	641666	3624.99	DFT-s-OFDM 16 QAM	1@49	21.91	16.41	0.0438
48	30	20	641666	3624.99	DFT-s-OFDM 64 QAM	25@12	20.35	14.85	0.0305
48	30	20	641666	3624.99	DFT-s-OFDM 64 QAM	1@1	20.19	14.69	0.0294
48	30	20	641666	3624.99	DFT-s-OFDM 64 QAM	1@49	20.40	14.90	0.0309
48	30	20	641666	3624.99	DFT-s-OFDM 256 QAM	25@12	18.39	12.89	0.0195
48	30	20	641666	3624.99	DFT-s-OFDM 256 QAM	1@1	18.12	12.62	0.0183
48	30	20	641666	3624.99	DFT-s-OFDM 256 QAM	1@49	18.25	12.75	0.0188
48	30	20	641666	3624.99	CP-OFDM QPSK	25@12	21.43	15.93	0.0392
48	30	20	641666	3624.99	CP-OFDM QPSK	1@1	21.11	15.61	0.0364
48	30	20	641666	3624.99	CP-OFDM QPSK	1@49	21.30	15.80	0.0380
48	30	20	646000	3690	DFT-s-OFDM PI/2 BPSK	25@12	22.52	17.02	0.0504
48	30	20	646000	3690	DFT-s-OFDM PI/2 BPSK	1@1	22.51	17.01	0.0502
48	30	20	646000	3690	DFT-s-OFDM PI/2 BPSK	1@49	22.41	16.91	0.0491
48	30	20	646000	3690	DFT-s-OFDM QPSK	25@12	22.57	17.07	0.0509
48	30	20	646000	3690	DFT-s-OFDM QPSK	1@1	22.55	17.05	0.0507
48	30	20	646000	3690	DFT-s-OFDM QPSK	1@49	22.44	16.94	0.0494
48	30	20	646000	3690	DFT-s-OFDM 16 QAM	25@12	21.60	16.10	0.0407
48	30	20	646000	3690	DFT-s-OFDM 16 QAM	1@1	21.54	16.04	0.0402
48	30	20	646000	3690	DFT-s-OFDM 16 QAM	1@49	21.41	15.91	0.0390
48	30	20	646000	3690	DFT-s-OFDM 64 QAM	25@12	20.04	14.54	0.0284
48	30	20	646000	3690	DFT-s-OFDM 64 QAM	1@1	20.05	14.55	0.0285
48	30	20	646000	3690	DFT-s-OFDM 64 QAM	1@49	19.89	14.39	0.0275
48	30	20	646000	3690	DFT-s-OFDM 256 QAM	25@12	17.96	12.46	0.0176
48	30	20	646000	3690	DFT-s-OFDM 256 QAM	1@1	17.82	12.32	0.0171
48	30	20	646000	3690	DFT-s-OFDM 256 QAM	1@49	17.74	12.24	0.0167
48	30	20	646000	3690	CP-OFDM QPSK	25@12	21.05	15.55	0.0359
48	30	20	646000	3690	CP-OFDM QPSK	1@1	21.07	15.57	0.0361



48	30	20	646000	3690	CP-OFDM QPSK	1@49	20.97	15.47	0.0352
48	30	30	637668	3565.02	DFT-s-OFDM PI/2 BPSK	36@18	22.50	17.00	0.0501
48	30	30	637668	3565.02	DFT-s-OFDM PI/2 BPSK	1@1	22.49	16.99	0.0500
48	30	30	637668	3565.02	DFT-s-OFDM PI/2 BPSK	1@76	22.40	16.90	0.0490
48	30	30	637668	3565.02	DFT-s-OFDM QPSK	36@18	22.51	17.01	0.0502
48	30	30	637668	3565.02	DFT-s-OFDM QPSK	1@1	22.47	16.97	0.0498
48	30	30	637668	3565.02	DFT-s-OFDM QPSK	1@76	22.37	16.87	0.0486
48	30	30	637668	3565.02	DFT-s-OFDM 16 QAM	36@18	21.48	15.98	0.0396
48	30	30	637668	3565.02	DFT-s-OFDM 16 QAM	1@1	21.52	16.02	0.0400
48	30	30	637668	3565.02	DFT-s-OFDM 16 QAM	1@76	21.44	15.94	0.0393
48	30	30	637668	3565.02	DFT-s-OFDM 64 QAM	36@18	20.09	14.59	0.0288
48	30	30	637668	3565.02	DFT-s-OFDM 64 QAM	1@1	19.92	14.42	0.0277
48	30	30	637668	3565.02	DFT-s-OFDM 64 QAM	1@76	19.90	14.40	0.0275
48	30	30	637668	3565.02	DFT-s-OFDM 256 QAM	36@18	18.03	12.53	0.0179
48	30	30	637668	3565.02	DFT-s-OFDM 256 QAM	1@1	17.92	12.42	0.0175
48	30	30	637668	3565.02	DFT-s-OFDM 256 QAM	1@76	17.78	12.28	0.0169
48	30	30	637668	3565.02	CP-OFDM QPSK	39@19	20.98	15.48	0.0353
48	30	30	637668	3565.02	CP-OFDM QPSK	1@1	20.90	15.40	0.0347
48	30	30	637668	3565.02	CP-OFDM QPSK	1@76	20.93	15.43	0.0349
48	30	30	641666	3624.99	DFT-s-OFDM PI/2 BPSK	36@18	22.83	17.33	0.0541
48	30	30	641666	3624.99	DFT-s-OFDM PI/2 BPSK	1@1	22.66	17.16	0.0520
48	30	30	641666	3624.99	DFT-s-OFDM PI/2 BPSK	1@76	22.91	17.41	0.0551
48	30	30	641666	3624.99	DFT-s-OFDM QPSK	36@18	22.91	17.41	0.0551
48	30	30	641666	3624.99	DFT-s-OFDM QPSK	1@1	22.68	17.18	0.0522
48	30	30	641666	3624.99	DFT-s-OFDM QPSK	1@76	22.94	17.44	0.0555
48	30	30	641666	3624.99	DFT-s-OFDM 16 QAM	36@18	21.94	16.44	0.0441
48	30	30	641666	3624.99	DFT-s-OFDM 16 QAM	1@1	21.65	16.15	0.0412
48	30	30	641666	3624.99	DFT-s-OFDM 16 QAM	1@76	21.97	16.47	0.0444
48	30	30	641666	3624.99	DFT-s-OFDM 64 QAM	36@18	20.46	14.96	0.0313
48	30	30	641666	3624.99	DFT-s-OFDM 64 QAM	1@1	20.11	14.61	0.0289
48	30	30	641666	3624.99	DFT-s-OFDM 64 QAM	1@76	20.54	15.04	0.0319
48	30	30	641666	3624.99	DFT-s-OFDM 256 QAM	36@18	18.37	12.87	0.0194
48	30	30	641666	3624.99	DFT-s-OFDM 256 QAM	1@1	18.04	12.54	0.0179
48	30	30	641666	3624.99	DFT-s-OFDM 256 QAM	1@76	18.26	12.76	0.0189
48	30	30	641666	3624.99	CP-OFDM QPSK	39@19	21.45	15.95	0.0394
48	30	30	641666	3624.99	CP-OFDM QPSK	1@1	21.08	15.58	0.0361
48	30	30	641666	3624.99	CP-OFDM QPSK	1@76	21.52	16.02	0.0400
48	30	30	645666	3684.99	DFT-s-OFDM PI/2 BPSK	36@18	22.59	17.09	0.0512
48	30	30	645666	3684.99	DFT-s-OFDM PI/2 BPSK	1@1	22.76	17.26	0.0532
48	30	30	645666	3684.99	DFT-s-OFDM PI/2 BPSK	1@76	22.43	16.93	0.0493
48	30	30	645666	3684.99	DFT-s-OFDM QPSK	36@18	22.62	17.12	0.0515
48	30	30	645666	3684.99	DFT-s-OFDM QPSK	1@1	22.78	17.28	0.0535



48	30	30	645666	3684.99	DFT-s-OFDM QPSK	1@76	22.43	16.93	0.0493
48	30	30	645666	3684.99	DFT-s-OFDM 16 QAM	36@18	21.58	16.08	0.0406
48	30	30	645666	3684.99	DFT-s-OFDM 16 QAM	1@1	21.78	16.28	0.0425
48	30	30	645666	3684.99	DFT-s-OFDM 16 QAM	1@76	21.41	15.91	0.0390
48	30	30	645666	3684.99	DFT-s-OFDM 64 QAM	36@18	20.14	14.64	0.0291
48	30	30	645666	3684.99	DFT-s-OFDM 64 QAM	1@1	20.26	14.76	0.0299
48	30	30	645666	3684.99	DFT-s-OFDM 64 QAM	1@76	19.93	14.43	0.0277
48	30	30	645666	3684.99	DFT-s-OFDM 256 QAM	36@18	18.16	12.66	0.0185
48	30	30	645666	3684.99	DFT-s-OFDM 256 QAM	1@1	18.13	12.63	0.0183
48	30	30	645666	3684.99	DFT-s-OFDM 256 QAM	1@76	17.83	12.33	0.0171
48	30	30	645666	3684.99	CP-OFDM QPSK	39@19	21.13	15.63	0.0366
48	30	30	645666	3684.99	CP-OFDM QPSK	1@1	21.13	15.63	0.0366
48	30	30	645666	3684.99	CP-OFDM QPSK	1@76	21.02	15.52	0.0356
48	30	40	638000	3570	DFT-s-OFDM PI/2 BPSK	50@25	22.70	17.20	0.0525
48	30	40	638000	3570	DFT-s-OFDM PI/2 BPSK	1@1	22.64	17.14	0.0518
48	30	40	638000	3570	DFT-s-OFDM PI/2 BPSK	1@104	22.46	16.96	0.0497
48	30	40	638000	3570	DFT-s-OFDM QPSK	50@25	22.67	17.17	0.0521
48	30	40	638000	3570	DFT-s-OFDM QPSK	1@1	22.65	17.15	0.0519
48	30	40	638000	3570	DFT-s-OFDM QPSK	1@104	22.49	16.99	0.0500
48	30	40	638000	3570	DFT-s-OFDM 16 QAM	50@25	21.66	16.16	0.0413
48	30	40	638000	3570	DFT-s-OFDM 16 QAM	1@1	21.65	16.15	0.0412
48	30	40	638000	3570	DFT-s-OFDM 16 QAM	1@104	21.49	15.99	0.0397
48	30	40	638000	3570	DFT-s-OFDM 64 QAM	50@25	20.20	14.70	0.0295
48	30	40	638000	3570	DFT-s-OFDM 64 QAM	1@1	20.26	14.76	0.0299
48	30	40	638000	3570	DFT-s-OFDM 64 QAM	1@104	20.03	14.53	0.0284
48	30	40	638000	3570	DFT-s-OFDM 256 QAM	50@25	18.19	12.69	0.0186
48	30	40	638000	3570	DFT-s-OFDM 256 QAM	1@1	18.02	12.52	0.0179
48	30	40	638000	3570	DFT-s-OFDM 256 QAM	1@104	17.84	12.34	0.0171
48	30	40	638000	3570	CP-OFDM QPSK	53@26	21.13	15.63	0.0366
48	30	40	638000	3570	CP-OFDM QPSK	1@1	21.03	15.53	0.0357
48	30	40	638000	3570	CP-OFDM QPSK	1@104	21.00	15.50	0.0355
48	30	40	641666	3624.99	DFT-s-OFDM PI/2 BPSK	50@25	22.96	17.46	0.0557
48	30	40	641666	3624.99	DFT-s-OFDM PI/2 BPSK	1@1	22.56	17.06	0.0508
48	30	40	641666	3624.99	DFT-s-OFDM PI/2 BPSK	1@104	22.87	17.37	0.0546
48	30	40	641666	3624.99	DFT-s-OFDM QPSK	50@25	22.93	17.43	0.0553
48	30	40	641666	3624.99	DFT-s-OFDM QPSK	1@1	22.56	17.06	0.0508
48	30	40	641666	3624.99	DFT-s-OFDM QPSK	1@104	22.91	17.41	0.0551
48	30	40	641666	3624.99	DFT-s-OFDM 16 QAM	50@25	21.89	16.39	0.0436
48	30	40	641666	3624.99	DFT-s-OFDM 16 QAM	1@1	21.57	16.07	0.0405
48	30	40	641666	3624.99	DFT-s-OFDM 16 QAM	1@104	21.99	16.49	0.0446
48	30	40	641666	3624.99	DFT-s-OFDM 64 QAM	50@25	20.45	14.95	0.0313
48	30	40	641666	3624.99	DFT-s-OFDM 64 QAM	1@1	20.22	14.72	0.0296



48	30	40	641666	3624.99	DFT-s-OFDM 64 QAM	1@104	20.36	14.86	0.0306
48	30	40	641666	3624.99	DFT-s-OFDM 256 QAM	50@25	18.35	12.85	0.0193
48	30	40	641666	3624.99	DFT-s-OFDM 256 QAM	1@1	17.91	12.41	0.0174
48	30	40	641666	3624.99	DFT-s-OFDM 256 QAM	1@104	18.22	12.72	0.0187
48	30	40	641666	3624.99	CP-OFDM QPSK	53@26	21.39	15.89	0.0388
48	30	40	641666	3624.99	CP-OFDM QPSK	1@1	21.03	15.53	0.0357
48	30	40	641666	3624.99	CP-OFDM QPSK	1@104	21.47	15.97	0.0395
48	30	40	645332	3679.98	DFT-s-OFDM PI/2 BPSK	50@25	22.61	17.11	0.0514
48	30	40	645332	3679.98	DFT-s-OFDM PI/2 BPSK	1@1	22.77	17.27	0.0533
48	30	40	645332	3679.98	DFT-s-OFDM PI/2 BPSK	1@104	22.32	16.82	0.0481
48	30	40	645332	3679.98	DFT-s-OFDM QPSK	50@25	22.59	17.09	0.0512
48	30	40	645332	3679.98	DFT-s-OFDM QPSK	1@1	22.78	17.28	0.0535
48	30	40	645332	3679.98	DFT-s-OFDM QPSK	1@104	22.36	16.86	0.0485
48	30	40	645332	3679.98	DFT-s-OFDM 16 QAM	50@25	21.56	16.06	0.0404
48	30	40	645332	3679.98	DFT-s-OFDM 16 QAM	1@1	21.77	16.27	0.0424
48	30	40	645332	3679.98	DFT-s-OFDM 16 QAM	1@104	21.31	15.81	0.0381
48	30	40	645332	3679.98	DFT-s-OFDM 64 QAM	50@25	20.10	14.60	0.0288
48	30	40	645332	3679.98	DFT-s-OFDM 64 QAM	1@1	20.33	14.83	0.0304
48	30	40	645332	3679.98	DFT-s-OFDM 64 QAM	1@104	19.86	14.36	0.0273
48	30	40	645332	3679.98	DFT-s-OFDM 256 QAM	50@25	18.08	12.58	0.0181
48	30	40	645332	3679.98	DFT-s-OFDM 256 QAM	1@1	18.07	12.57	0.0181
48	30	40	645332	3679.98	DFT-s-OFDM 256 QAM	1@104	17.75	12.25	0.0168
48	30	40	645332	3679.98	CP-OFDM QPSK	53@26	21.08	15.58	0.0361
48	30	40	645332	3679.98	CP-OFDM QPSK	1@1	21.17	15.67	0.0369
48	30	40	645332	3679.98	CP-OFDM QPSK	1@104	20.92	15.42	0.0348
48	30	50	638334	3575.01	DFT-s-OFDM PI/2 BPSK	64@32	22.59	17.09	0.0512
48	30	50	638334	3575.01	DFT-s-OFDM PI/2 BPSK	1@1	22.49	16.99	0.0500
48	30	50	638334	3575.01	DFT-s-OFDM PI/2 BPSK	1@131	22.40	16.90	0.0490
48	30	50	638334	3575.01	DFT-s-OFDM QPSK	64@32	22.54	17.04	0.0506
48	30	50	638334	3575.01	DFT-s-OFDM QPSK	1@1	22.52	17.02	0.0504
48	30	50	638334	3575.01	DFT-s-OFDM QPSK	1@131	22.36	16.86	0.0485
48	30	50	638334	3575.01	DFT-s-OFDM 16 QAM	64@32	21.54	16.04	0.0402
48	30	50	638334	3575.01	DFT-s-OFDM 16 QAM	1@1	21.49	15.99	0.0397
48	30	50	638334	3575.01	DFT-s-OFDM 16 QAM	1@131	21.47	15.97	0.0395
48	30	50	638334	3575.01	DFT-s-OFDM 64 QAM	64@32	20.05	14.55	0.0285
48	30	50	638334	3575.01	DFT-s-OFDM 64 QAM	1@1	20.04	14.54	0.0284
48	30	50	638334	3575.01	DFT-s-OFDM 64 QAM	1@131	19.83	14.33	0.0271
48	30	50	638334	3575.01	DFT-s-OFDM 256 QAM	64@32	18.05	12.55	0.0180
48	30	50	638334	3575.01	DFT-s-OFDM 256 QAM	1@1	17.87	12.37	0.0173
48	30	50	638334	3575.01	DFT-s-OFDM 256 QAM	1@131	17.70	12.20	0.0166
48	30	50	638334	3575.01	CP-OFDM QPSK	67@33	21.02	15.52	0.0356
48	30	50	638334	3575.01	CP-OFDM QPSK	1@1	20.94	15.44	0.0350



48	30	50	638334	3575.01	CP-OFDM QPSK	1@131	20.89	15.39	0.0346
48	30	50	641666	3624.99	DFT-s-OFDM PI/2 BPSK	64@32	22.88	17.38	0.0547
48	30	50	641666	3624.99	DFT-s-OFDM PI/2 BPSK	1@1	22.48	16.98	0.0499
48	30	50	641666	3624.99	DFT-s-OFDM PI/2 BPSK	1@131	22.81	17.31	0.0538
48	30	50	641666	3624.99	DFT-s-OFDM QPSK	64@32	22.89	17.39	0.0548
48	30	50	641666	3624.99	DFT-s-OFDM QPSK	1@1	22.42	16.92	0.0492
48	30	50	641666	3624.99	DFT-s-OFDM QPSK	1@131	22.76	17.26	0.0532
48	30	50	641666	3624.99	DFT-s-OFDM 16 QAM	64@32	21.87	16.37	0.0434
48	30	50	641666	3624.99	DFT-s-OFDM 16 QAM	1@1	21.47	15.97	0.0395
48	30	50	641666	3624.99	DFT-s-OFDM 16 QAM	1@131	21.90	16.40	0.0437
48	30	50	641666	3624.99	DFT-s-OFDM 64 QAM	64@32	20.44	14.94	0.0312
48	30	50	641666	3624.99	DFT-s-OFDM 64 QAM	1@1	20.03	14.53	0.0284
48	30	50	641666	3624.99	DFT-s-OFDM 64 QAM	1@131	20.41	14.91	0.0310
48	30	50	641666	3624.99	DFT-s-OFDM 256 QAM	64@32	18.38	12.88	0.0194
48	30	50	641666	3624.99	DFT-s-OFDM 256 QAM	1@1	17.81	12.31	0.0170
48	30	50	641666	3624.99	DFT-s-OFDM 256 QAM	1@131	18.13	12.63	0.0183
48	30	50	641666	3624.99	CP-OFDM QPSK	67@33	21.37	15.87	0.0386
48	30	50	641666	3624.99	CP-OFDM QPSK	1@1	20.97	15.47	0.0352
48	30	50	641666	3624.99	CP-OFDM QPSK	1@131	21.30	15.80	0.0380
48	30	50	645000	3675	DFT-s-OFDM PI/2 BPSK	64@32	22.59	17.09	0.0512
48	30	50	645000	3675	DFT-s-OFDM PI/2 BPSK	1@1	22.66	17.16	0.0520
48	30	50	645000	3675	DFT-s-OFDM PI/2 BPSK	1@131	22.22	16.72	0.0470
48	30	50	645000	3675	DFT-s-OFDM QPSK	64@32	22.56	17.06	0.0508
48	30	50	645000	3675	DFT-s-OFDM QPSK	1@1	22.61	17.11	0.0514
48	30	50	645000	3675	DFT-s-OFDM QPSK	1@131	22.13	16.63	0.0460
48	30	50	645000	3675	DFT-s-OFDM 16 QAM	64@32	21.57	16.07	0.0405
48	30	50	645000	3675	DFT-s-OFDM 16 QAM	1@1	21.66	16.16	0.0413
48	30	50	645000	3675	DFT-s-OFDM 16 QAM	1@131	21.22	15.72	0.0373
48	30	50	645000	3675	DFT-s-OFDM 64 QAM	64@32	20.11	14.61	0.0289
48	30	50	645000	3675	DFT-s-OFDM 64 QAM	1@1	20.18	14.68	0.0294
48	30	50	645000	3675	DFT-s-OFDM 64 QAM	1@131	19.77	14.27	0.0267
48	30	50	645000	3675	DFT-s-OFDM 256 QAM	64@32	18.11	12.61	0.0182
48	30	50	645000	3675	DFT-s-OFDM 256 QAM	1@1	17.95	12.45	0.0176
48	30	50	645000	3675	DFT-s-OFDM 256 QAM	1@131	17.68	12.18	0.0165
48	30	50	645000	3675	CP-OFDM QPSK	67@33	21.03	15.53	0.0357
48	30	50	645000	3675	CP-OFDM QPSK	1@1	21.22	15.72	0.0373
48	30	50	645000	3675	CP-OFDM QPSK	1@131	20.79	15.29	0.0338
48	30	60	638668	3580.02	DFT-s-OFDM PI/2 BPSK	81@40	22.52	17.02	0.0504
48	30	60	638668	3580.02	DFT-s-OFDM PI/2 BPSK	1@1	22.48	16.98	0.0499
48	30	60	638668	3580.02	DFT-s-OFDM PI/2 BPSK	1@160	22.43	16.93	0.0493
48	30	60	638668	3580.02	DFT-s-OFDM QPSK	81@40	22.51	17.01	0.0502
48	30	60	638668	3580.02	DFT-s-OFDM QPSK	1@1	22.50	17.00	0.0501



48	30	60	638668	3580.02	DFT-s-OFDM QPSK	1@160	22.44	16.94	0.0494
48	30	60	638668	3580.02	DFT-s-OFDM 16 QAM	81@40	21.53	16.03	0.0401
48	30	60	638668	3580.02	DFT-s-OFDM 16 QAM	1@1	21.53	16.03	0.0401
48	30	60	638668	3580.02	DFT-s-OFDM 16 QAM	1@160	21.55	16.05	0.0403
48	30	60	638668	3580.02	DFT-s-OFDM 64 QAM	81@40	20.10	14.60	0.0288
48	30	60	638668	3580.02	DFT-s-OFDM 64 QAM	1@1	20.10	14.60	0.0288
48	30	60	638668	3580.02	DFT-s-OFDM 64 QAM	1@160	19.97	14.47	0.0280
48	30	60	638668	3580.02	DFT-s-OFDM 256 QAM	81@40	18.03	12.53	0.0179
48	30	60	638668	3580.02	DFT-s-OFDM 256 QAM	1@1	17.90	12.40	0.0174
48	30	60	638668	3580.02	DFT-s-OFDM 256 QAM	1@160	17.82	12.32	0.0171
48	30	60	638668	3580.02	CP-OFDM QPSK	81@40	21.00	15.50	0.0355
48	30	60	638668	3580.02	CP-OFDM QPSK	1@1	21.05	15.55	0.0359
48	30	60	638668	3580.02	CP-OFDM QPSK	1@160	21.05	15.55	0.0359
48	30	60	641666	3624.99	DFT-s-OFDM PI/2 BPSK	81@40	22.84	17.34	0.0542
48	30	60	641666	3624.99	DFT-s-OFDM PI/2 BPSK	1@1	22.39	16.89	0.0489
48	30	60	641666	3624.99	DFT-s-OFDM PI/2 BPSK	1@160	22.82	17.32	0.0540
48	30	60	641666	3624.99	DFT-s-OFDM QPSK	81@40	22.86	17.36	0.0545
48	30	60	641666	3624.99	DFT-s-OFDM QPSK	1@1	22.35	16.85	0.0484
48	30	60	641666	3624.99	DFT-s-OFDM QPSK	1@160	22.80	17.30	0.0537
48	30	60	641666	3624.99	DFT-s-OFDM 16 QAM	81@40	21.86	16.36	0.0433
48	30	60	641666	3624.99	DFT-s-OFDM 16 QAM	1@1	21.42	15.92	0.0391
48	30	60	641666	3624.99	DFT-s-OFDM 16 QAM	1@160	21.85	16.35	0.0432
48	30	60	641666	3624.99	DFT-s-OFDM 64 QAM	81@40	20.42	14.92	0.0310
48	30	60	641666	3624.99	DFT-s-OFDM 64 QAM	1@1	19.89	14.39	0.0275
48	30	60	641666	3624.99	DFT-s-OFDM 64 QAM	1@160	20.32	14.82	0.0303
48	30	60	641666	3624.99	DFT-s-OFDM 256 QAM	81@40	18.33	12.83	0.0192
48	30	60	641666	3624.99	DFT-s-OFDM 256 QAM	1@1	17.75	12.25	0.0168
48	30	60	641666	3624.99	DFT-s-OFDM 256 QAM	1@160	18.11	12.61	0.0182
48	30	60	641666	3624.99	CP-OFDM QPSK	81@40	21.33	15.83	0.0383
48	30	60	641666	3624.99	CP-OFDM QPSK	1@1	20.94	15.44	0.0350
48	30	60	641666	3624.99	CP-OFDM QPSK	1@160	21.38	15.88	0.0387
48	30	60	644666	3669.99	DFT-s-OFDM PI/2 BPSK	81@40	22.70	17.20	0.0525
48	30	60	644666	3669.99	DFT-s-OFDM PI/2 BPSK	1@1	22.71	17.21	0.0526
48	30	60	644666	3669.99	DFT-s-OFDM PI/2 BPSK	1@160	22.28	16.78	0.0476
48	30	60	644666	3669.99	DFT-s-OFDM QPSK	81@40	22.67	17.17	0.0521
48	30	60	644666	3669.99	DFT-s-OFDM QPSK	1@1	22.68	17.18	0.0522
48	30	60	644666	3669.99	DFT-s-OFDM QPSK	1@160	22.28	16.78	0.0476
48	30	60	644666	3669.99	DFT-s-OFDM 16 QAM	81@40	21.72	16.22	0.0419
48	30	60	644666	3669.99	DFT-s-OFDM 16 QAM	1@1	21.69	16.19	0.0416
48	30	60	644666	3669.99	DFT-s-OFDM 16 QAM	1@160	21.36	15.86	0.0385
48	30	60	644666	3669.99	DFT-s-OFDM 64 QAM	81@40	20.26	14.76	0.0299
48	30	60	644666	3669.99	DFT-s-OFDM 64 QAM	1@1	20.30	14.80	0.0302



48	30	60	644666	3669.99	DFT-s-OFDM 64 QAM	1@160	19.81	14.31	0.0270
48	30	60	644666	3669.99	DFT-s-OFDM 256 QAM	81@40	18.20	12.70	0.0186
48	30	60	644666	3669.99	DFT-s-OFDM 256 QAM	1@1	18.02	12.52	0.0179
48	30	60	644666	3669.99	DFT-s-OFDM 256 QAM	1@160	17.72	12.22	0.0167
48	30	60	644666	3669.99	CP-OFDM QPSK	81@40	21.17	15.67	0.0369
48	30	60	644666	3669.99	CP-OFDM QPSK	1@1	21.16	15.66	0.0368
48	30	60	644666	3669.99	CP-OFDM QPSK	1@160	20.71	15.21	0.0332
48	30	70	639000	3585	DFT-s-OFDM PI/2 BPSK	90@45	22.34	16.84	0.0483
48	30	70	639000	3585	DFT-s-OFDM PI/2 BPSK	1@1	22.48	16.98	0.0499
48	30	70	639000	3585	DFT-s-OFDM PI/2 BPSK	1@187	22.43	16.93	0.0493
48	30	70	639000	3585	DFT-s-OFDM QPSK	90@45	22.32	16.82	0.0481
48	30	70	639000	3585	DFT-s-OFDM QPSK	1@1	22.41	16.91	0.0491
48	30	70	639000	3585	DFT-s-OFDM QPSK	1@187	22.44	16.94	0.0494
48	30	70	639000	3585	DFT-s-OFDM 16 QAM	90@45	21.39	15.89	0.0388
48	30	70	639000	3585	DFT-s-OFDM 16 QAM	1@1	21.45	15.95	0.0394
48	30	70	639000	3585	DFT-s-OFDM 16 QAM	1@187	21.48	15.98	0.0396
48	30	70	639000	3585	DFT-s-OFDM 64 QAM	90@45	19.90	14.40	0.0275
48	30	70	639000	3585	DFT-s-OFDM 64 QAM	1@1	19.99	14.49	0.0281
48	30	70	639000	3585	DFT-s-OFDM 64 QAM	1@187	20.02	14.52	0.0283
48	30	70	639000	3585	DFT-s-OFDM 256 QAM	90@45	17.91	12.41	0.0174
48	30	70	639000	3585	DFT-s-OFDM 256 QAM	1@1	17.93	12.43	0.0175
48	30	70	639000	3585	DFT-s-OFDM 256 QAM	1@187	17.89	12.39	0.0173
48	30	70	639000	3585	CP-OFDM QPSK	95@47	20.82	15.32	0.0340
48	30	70	639000	3585	CP-OFDM QPSK	1@1	20.87	15.37	0.0344
48	30	70	639000	3585	CP-OFDM QPSK	1@187	20.85	15.35	0.0343
48	30	70	641666	3624.99	DFT-s-OFDM PI/2 BPSK	90@45	22.76	17.26	0.0532
48	30	70	641666	3624.99	DFT-s-OFDM PI/2 BPSK	1@1	22.38	16.88	0.0488
48	30	70	641666	3624.99	DFT-s-OFDM PI/2 BPSK	1@187	22.66	17.16	0.0520
48	30	70	641666	3624.99	DFT-s-OFDM QPSK	90@45	22.72	17.22	0.0527
48	30	70	641666	3624.99	DFT-s-OFDM QPSK	1@1	22.34	16.84	0.0483
48	30	70	641666	3624.99	DFT-s-OFDM QPSK	1@187	22.63	17.13	0.0516
48	30	70	641666	3624.99	DFT-s-OFDM 16 QAM	90@45	21.72	16.22	0.0419
48	30	70	641666	3624.99	DFT-s-OFDM 16 QAM	1@1	21.37	15.87	0.0386
48	30	70	641666	3624.99	DFT-s-OFDM 16 QAM	1@187	21.70	16.20	0.0417
48	30	70	641666	3624.99	DFT-s-OFDM 64 QAM	90@45	20.25	14.75	0.0299
48	30	70	641666	3624.99	DFT-s-OFDM 64 QAM	1@1	19.94	14.44	0.0278
48	30	70	641666	3624.99	DFT-s-OFDM 64 QAM	1@187	20.25	14.75	0.0299
48	30	70	641666	3624.99	DFT-s-OFDM 256 QAM	90@45	18.34	12.84	0.0192
48	30	70	641666	3624.99	DFT-s-OFDM 256 QAM	1@1	17.76	12.26	0.0168
48	30	70	641666	3624.99	DFT-s-OFDM 256 QAM	1@187	18.07	12.57	0.0181
48	30	70	641666	3624.99	CP-OFDM QPSK	95@47	21.24	15.74	0.0375
48	30	70	641666	3624.99	CP-OFDM QPSK	1@1	20.96	15.46	0.0352



48	30	70	641666	3624.99	CP-OFDM QPSK	1@187	21.22	15.72	0.0373
48	30	70	644332	3664.98	DFT-s-OFDM PI/2 BPSK	90@45	22.76	17.26	0.0532
48	30	70	644332	3664.98	DFT-s-OFDM PI/2 BPSK	1@1	22.75	17.25	0.0531
48	30	70	644332	3664.98	DFT-s-OFDM PI/2 BPSK	1@187	22.22	16.72	0.0470
48	30	70	644332	3664.98	DFT-s-OFDM QPSK	90@45	22.76	17.26	0.0532
48	30	70	644332	3664.98	DFT-s-OFDM QPSK	1@1	22.66	17.16	0.0520
48	30	70	644332	3664.98	DFT-s-OFDM QPSK	1@187	22.24	16.74	0.0472
48	30	70	644332	3664.98	DFT-s-OFDM 16 QAM	90@45	21.77	16.27	0.0424
48	30	70	644332	3664.98	DFT-s-OFDM 16 QAM	1@1	21.68	16.18	0.0415
48	30	70	644332	3664.98	DFT-s-OFDM 16 QAM	1@187	21.27	15.77	0.0378
48	30	70	644332	3664.98	DFT-s-OFDM 64 QAM	90@45	20.28	14.78	0.0301
48	30	70	644332	3664.98	DFT-s-OFDM 64 QAM	1@1	20.27	14.77	0.0300
48	30	70	644332	3664.98	DFT-s-OFDM 64 QAM	1@187	19.79	14.29	0.0269
48	30	70	644332	3664.98	DFT-s-OFDM 256 QAM	90@45	18.31	12.81	0.0191
48	30	70	644332	3664.98	DFT-s-OFDM 256 QAM	1@1	18.09	12.59	0.0182
48	30	70	644332	3664.98	DFT-s-OFDM 256 QAM	1@187	17.70	12.20	0.0166
48	30	70	644332	3664.98	CP-OFDM QPSK	95@47	21.20	15.70	0.0372
48	30	70	644332	3664.98	CP-OFDM QPSK	1@1	21.15	15.65	0.0367
48	30	70	644332	3664.98	CP-OFDM QPSK	1@187	20.67	15.17	0.0329
48	30	80	639334	3590.01	DFT-s-OFDM PI/2 BPSK	108@54	22.53	17.03	0.0505
48	30	80	639334	3590.01	DFT-s-OFDM PI/2 BPSK	1@1	22.57	17.07	0.0509
48	30	80	639334	3590.01	DFT-s-OFDM PI/2 BPSK	1@215	22.76	17.26	0.0532
48	30	80	639334	3590.01	DFT-s-OFDM QPSK	108@54	22.52	17.02	0.0504
48	30	80	639334	3590.01	DFT-s-OFDM QPSK	1@1	22.53	17.03	0.0505
48	30	80	639334	3590.01	DFT-s-OFDM QPSK	1@215	22.69	17.19	0.0524
48	30	80	639334	3590.01	DFT-s-OFDM 16 QAM	108@54	21.53	16.03	0.0401
48	30	80	639334	3590.01	DFT-s-OFDM 16 QAM	1@1	21.55	16.05	0.0403
48	30	80	639334	3590.01	DFT-s-OFDM 16 QAM	1@215	21.80	16.30	0.0427
48	30	80	639334	3590.01	DFT-s-OFDM 64 QAM	108@54	20.05	14.55	0.0285
48	30	80	639334	3590.01	DFT-s-OFDM 64 QAM	1@1	20.12	14.62	0.0290
48	30	80	639334	3590.01	DFT-s-OFDM 64 QAM	1@215	20.33	14.83	0.0304
48	30	80	639334	3590.01	DFT-s-OFDM 256 QAM	108@54	18.13	12.63	0.0183
48	30	80	639334	3590.01	DFT-s-OFDM 256 QAM	1@1	18.06	12.56	0.0180
48	30	80	639334	3590.01	DFT-s-OFDM 256 QAM	1@215	18.16	12.66	0.0185
48	30	80	639334	3590.01	CP-OFDM QPSK	109@54	20.96	15.46	0.0352
48	30	80	639334	3590.01	CP-OFDM QPSK	1@1	21.03	15.53	0.0357
48	30	80	639334	3590.01	CP-OFDM QPSK	1@215	21.30	15.80	0.0380
48	30	80	641666	3624.99	DFT-s-OFDM PI/2 BPSK	108@54	22.80	17.30	0.0537
48	30	80	641666	3624.99	DFT-s-OFDM PI/2 BPSK	1@1	22.47	16.97	0.0498
48	30	80	641666	3624.99	DFT-s-OFDM PI/2 BPSK	1@215	22.69	17.19	0.0524
48	30	80	641666	3624.99	DFT-s-OFDM QPSK	108@54	22.80	17.30	0.0537
48	30	80	641666	3624.99	DFT-s-OFDM QPSK	1@1	22.45	16.95	0.0495



48	30	80	641666	3624.99	DFT-s-OFDM QPSK	1@215	22.73	17.23	0.0528
48	30	80	641666	3624.99	DFT-s-OFDM 16 QAM	108@54	21.83	16.33	0.0430
48	30	80	641666	3624.99	DFT-s-OFDM 16 QAM	1@1	21.54	16.04	0.0402
48	30	80	641666	3624.99	DFT-s-OFDM 16 QAM	1@215	21.78	16.28	0.0425
48	30	80	641666	3624.99	DFT-s-OFDM 64 QAM	108@54	20.36	14.86	0.0306
48	30	80	641666	3624.99	DFT-s-OFDM 64 QAM	1@1	20.02	14.52	0.0283
48	30	80	641666	3624.99	DFT-s-OFDM 64 QAM	1@215	20.33	14.83	0.0304
48	30	80	641666	3624.99	DFT-s-OFDM 256 QAM	108@54	18.41	12.91	0.0195
48	30	80	641666	3624.99	DFT-s-OFDM 256 QAM	1@1	17.90	12.40	0.0174
48	30	80	641666	3624.99	DFT-s-OFDM 256 QAM	1@215	18.15	12.65	0.0184
48	30	80	641666	3624.99	CP-OFDM QPSK	109@54	21.27	15.77	0.0378
48	30	80	641666	3624.99	CP-OFDM QPSK	1@1	20.96	15.46	0.0352
48	30	80	641666	3624.99	CP-OFDM QPSK	1@215	21.12	15.62	0.0365
48	30	80	644000	3660	DFT-s-OFDM PI/2 BPSK	108@54	22.74	17.24	0.0530
48	30	80	644000	3660	DFT-s-OFDM PI/2 BPSK	1@1	22.61	17.11	0.0514
48	30	80	644000	3660	DFT-s-OFDM PI/2 BPSK	1@215	22.34	16.84	0.0483
48	30	80	644000	3660	DFT-s-OFDM QPSK	108@54	22.77	17.27	0.0533
48	30	80	644000	3660	DFT-s-OFDM QPSK	1@1	22.62	17.12	0.0515
48	30	80	644000	3660	DFT-s-OFDM QPSK	1@215	22.36	16.86	0.0485
48	30	80	644000	3660	DFT-s-OFDM 16 QAM	108@54	21.81	16.31	0.0428
48	30	80	644000	3660	DFT-s-OFDM 16 QAM	1@1	21.65	16.15	0.0412
48	30	80	644000	3660	DFT-s-OFDM 16 QAM	1@215	21.40	15.90	0.0389
48	30	80	644000	3660	DFT-s-OFDM 64 QAM	108@54	20.34	14.84	0.0305
48	30	80	644000	3660	DFT-s-OFDM 64 QAM	1@1	20.20	14.70	0.0295
48	30	80	644000	3660	DFT-s-OFDM 64 QAM	1@215	19.92	14.42	0.0277
48	30	80	644000	3660	DFT-s-OFDM 256 QAM	108@54	18.37	12.87	0.0194
48	30	80	644000	3660	DFT-s-OFDM 256 QAM	1@1	18.05	12.55	0.0180
48	30	80	644000	3660	DFT-s-OFDM 256 QAM	1@215	17.82	12.32	0.0171
48	30	80	644000	3660	CP-OFDM QPSK	109@54	21.25	15.75	0.0376
48	30	80	644000	3660	CP-OFDM QPSK	1@1	21.10	15.60	0.0363
48	30	80	644000	3660	CP-OFDM QPSK	1@215	20.75	15.25	0.0335
48	30	90	639668	3595.02	DFT-s-OFDM PI/2 BPSK	120@60	22.40	16.90	0.0490
48	30	90	639668	3595.02	DFT-s-OFDM PI/2 BPSK	1@1	22.49	16.99	0.0500
48	30	90	639668	3595.02	DFT-s-OFDM PI/2 BPSK	1@243	22.66	17.16	0.0520
48	30	90	639668	3595.02	DFT-s-OFDM QPSK	120@60	22.40	16.90	0.0490
48	30	90	639668	3595.02	DFT-s-OFDM QPSK	1@1	22.40	16.90	0.0490
48	30	90	639668	3595.02	DFT-s-OFDM QPSK	1@243	22.61	17.11	0.0514
48	30	90	639668	3595.02	DFT-s-OFDM 16 QAM	120@60	21.37	15.87	0.0386
48	30	90	639668	3595.02	DFT-s-OFDM 16 QAM	1@1	21.46	15.96	0.0394
48	30	90	639668	3595.02	DFT-s-OFDM 16 QAM	1@243	21.71	16.21	0.0418
48	30	90	639668	3595.02	DFT-s-OFDM 64 QAM	120@60	19.90	14.40	0.0275
48	30	90	639668	3595.02	DFT-s-OFDM 64 QAM	1@1	20.05	14.55	0.0285



48	30	90	639668	3595.02	DFT-s-OFDM 64 QAM	1@243	20.18	14.68	0.0294
48	30	90	639668	3595.02	DFT-s-OFDM 256 QAM	120@60	17.96	12.46	0.0176
48	30	90	639668	3595.02	DFT-s-OFDM 256 QAM	1@1	17.91	12.41	0.0174
48	30	90	639668	3595.02	DFT-s-OFDM 256 QAM	1@243	18.06	12.56	0.0180
48	30	90	639668	3595.02	CP-OFDM QPSK	123@61	20.81	15.31	0.0340
48	30	90	639668	3595.02	CP-OFDM QPSK	1@1	20.84	15.34	0.0342
48	30	90	639668	3595.02	CP-OFDM QPSK	1@243	21.10	15.60	0.0363
48	30	90	641666	3624.99	DFT-s-OFDM PI/2 BPSK	120@60	22.71	17.21	0.0526
48	30	90	641666	3624.99	DFT-s-OFDM PI/2 BPSK	1@1	22.36	16.86	0.0485
48	30	90	641666	3624.99	DFT-s-OFDM PI/2 BPSK	1@243	22.56	17.06	0.0508
48	30	90	641666	3624.99	DFT-s-OFDM QPSK	120@60	22.70	17.20	0.0525
48	30	90	641666	3624.99	DFT-s-OFDM QPSK	1@1	22.35	16.85	0.0484
48	30	90	641666	3624.99	DFT-s-OFDM QPSK	1@243	22.51	17.01	0.0502
48	30	90	641666	3624.99	DFT-s-OFDM 16 QAM	120@60	21.70	16.20	0.0417
48	30	90	641666	3624.99	DFT-s-OFDM 16 QAM	1@1	21.37	15.87	0.0386
48	30	90	641666	3624.99	DFT-s-OFDM 16 QAM	1@243	21.61	16.11	0.0408
48	30	90	641666	3624.99	DFT-s-OFDM 64 QAM	120@60	20.26	14.76	0.0299
48	30	90	641666	3624.99	DFT-s-OFDM 64 QAM	1@1	19.98	14.48	0.0281
48	30	90	641666	3624.99	DFT-s-OFDM 64 QAM	1@243	20.09	14.59	0.0288
48	30	90	641666	3624.99	DFT-s-OFDM 256 QAM	120@60	18.36	12.86	0.0193
48	30	90	641666	3624.99	DFT-s-OFDM 256 QAM	1@1	17.84	12.34	0.0171
48	30	90	641666	3624.99	DFT-s-OFDM 256 QAM	1@243	17.99	12.49	0.0177
48	30	90	641666	3624.99	CP-OFDM QPSK	123@61	21.21	15.71	0.0372
48	30	90	641666	3624.99	CP-OFDM QPSK	1@1	20.77	15.27	0.0337
48	30	90	641666	3624.99	CP-OFDM QPSK	1@243	21.05	15.55	0.0359
48	30	90	643666	3654.99	DFT-s-OFDM PI/2 BPSK	120@60	22.84	17.34	0.0542
48	30	90	643666	3654.99	DFT-s-OFDM PI/2 BPSK	1@1	22.53	17.03	0.0505
48	30	90	643666	3654.99	DFT-s-OFDM PI/2 BPSK	1@243	22.21	16.71	0.0469
48	30	90	643666	3654.99	DFT-s-OFDM QPSK	120@60	22.80	17.30	0.0537
48	30	90	643666	3654.99	DFT-s-OFDM QPSK	1@1	22.50	17.00	0.0501
48	30	90	643666	3654.99	DFT-s-OFDM QPSK	1@243	22.21	16.71	0.0469
48	30	90	643666	3654.99	DFT-s-OFDM 16 QAM	120@60	21.81	16.31	0.0428
48	30	90	643666	3654.99	DFT-s-OFDM 16 QAM	1@1	21.51	16.01	0.0399
48	30	90	643666	3654.99	DFT-s-OFDM 16 QAM	1@243	21.26	15.76	0.0377
48	30	90	643666	3654.99	DFT-s-OFDM 64 QAM	120@60	20.39	14.89	0.0308
48	30	90	643666	3654.99	DFT-s-OFDM 64 QAM	1@1	20.11	14.61	0.0289
48	30	90	643666	3654.99	DFT-s-OFDM 64 QAM	1@243	19.74	14.24	0.0265
48	30	90	643666	3654.99	DFT-s-OFDM 256 QAM	120@60	18.43	12.93	0.0196
48	30	90	643666	3654.99	DFT-s-OFDM 256 QAM	1@1	17.89	12.39	0.0173
48	30	90	643666	3654.99	DFT-s-OFDM 256 QAM	1@243	17.63	12.13	0.0163
48	30	90	643666	3654.99	CP-OFDM QPSK	123@61	21.26	15.76	0.0377
48	30	90	643666	3654.99	CP-OFDM QPSK	1@1	20.89	15.39	0.0346



48	30	90	643666	3654.99	CP-OFDM QPSK	1@243	20.59	15.09	0.0323
48	30	100	640000	3600	DFT-s-OFDM PI/2 BPSK	135@67	22.54	17.04	0.0506
48	30	100	640000	3600	DFT-s-OFDM PI/2 BPSK	1@1	22.50	17.00	0.0501
48	30	100	640000	3600	DFT-s-OFDM PI/2 BPSK	1@271	22.71	17.21	0.0526
48	30	100	640000	3600	DFT-s-OFDM QPSK	135@67	22.57	17.07	0.0509
48	30	100	640000	3600	DFT-s-OFDM QPSK	1@1	22.53	17.03	0.0505
48	30	100	640000	3600	DFT-s-OFDM QPSK	1@271	22.74	17.24	0.0530
48	30	100	640000	3600	DFT-s-OFDM 16 QAM	135@67	21.59	16.09	0.0406
48	30	100	640000	3600	DFT-s-OFDM 16 QAM	1@1	21.61	16.11	0.0408
48	30	100	640000	3600	DFT-s-OFDM 16 QAM	1@271	21.81	16.31	0.0428
48	30	100	640000	3600	DFT-s-OFDM 64 QAM	135@67	20.11	14.61	0.0289
48	30	100	640000	3600	DFT-s-OFDM 64 QAM	1@1	20.13	14.63	0.0290
48	30	100	640000	3600	DFT-s-OFDM 64 QAM	1@271	20.38	14.88	0.0308
48	30	100	640000	3600	DFT-s-OFDM 256 QAM	135@67	18.20	12.70	0.0186
48	30	100	640000	3600	DFT-s-OFDM 256 QAM	1@1	18.02	12.52	0.0179
48	30	100	640000	3600	DFT-s-OFDM 256 QAM	1@271	18.14	12.64	0.0184
48	30	100	640000	3600	CP-OFDM QPSK	137@68	21.05	15.55	0.0359
48	30	100	640000	3600	CP-OFDM QPSK	1@1	20.94	15.44	0.0350
48	30	100	640000	3600	CP-OFDM QPSK	1@271	21.20	15.70	0.0372
48	30	100	641666	3624.99	DFT-s-OFDM PI/2 BPSK	135@67	22.83	17.33	0.0541
48	30	100	641666	3624.99	DFT-s-OFDM PI/2 BPSK	1@1	22.51	17.01	0.0502
48	30	100	641666	3624.99	DFT-s-OFDM PI/2 BPSK	1@271	22.54	17.04	0.0506
48	30	100	641666	3624.99	DFT-s-OFDM QPSK	135@67	22.82	17.32	0.0540
48	30	100	641666	3624.99	DFT-s-OFDM QPSK	1@1	22.50	17.00	0.0501
48	30	100	641666	3624.99	DFT-s-OFDM QPSK	1@271	22.52	17.02	0.0504
48	30	100	641666	3624.99	DFT-s-OFDM 16 QAM	135@67	21.84	16.34	0.0431
48	30	100	641666	3624.99	DFT-s-OFDM 16 QAM	1@1	21.55	16.05	0.0403
48	30	100	641666	3624.99	DFT-s-OFDM 16 QAM	1@271	21.58	16.08	0.0406
48	30	100	641666	3624.99	DFT-s-OFDM 64 QAM	135@67	20.37	14.87	0.0307
48	30	100	641666	3624.99	DFT-s-OFDM 64 QAM	1@1	20.10	14.60	0.0288
48	30	100	641666	3624.99	DFT-s-OFDM 64 QAM	1@271	20.15	14.65	0.0292
48	30	100	641666	3624.99	DFT-s-OFDM 256 QAM	135@67	18.41	12.91	0.0195
48	30	100	641666	3624.99	DFT-s-OFDM 256 QAM	1@1	17.89	12.39	0.0173
48	30	100	641666	3624.99	DFT-s-OFDM 256 QAM	1@271	17.94	12.44	0.0175
48	30	100	641666	3624.99	CP-OFDM QPSK	137@68	21.29	15.79	0.0379
48	30	100	641666	3624.99	CP-OFDM QPSK	1@1	20.88	15.38	0.0345
48	30	100	641666	3624.99	CP-OFDM QPSK	1@271	21.00	15.50	0.0355
48	30	100	643332	3649.98	DFT-s-OFDM PI/2 BPSK	135@67	22.77	17.27	0.0533
48	30	100	643332	3649.98	DFT-s-OFDM PI/2 BPSK	1@1	22.39	16.89	0.0489
48	30	100	643332	3649.98	DFT-s-OFDM PI/2 BPSK	1@271	22.30	16.80	0.0479
48	30	100	643332	3649.98	DFT-s-OFDM QPSK	135@67	22.74	17.24	0.0530
48	30	100	643332	3649.98	DFT-s-OFDM QPSK	1@1	22.33	16.83	0.0482



48	30	100	643332	3649.98	DFT-s-OFDM QPSK	1@271	22.27	16.77	0.0475
48	30	100	643332	3649.98	DFT-s-OFDM 16 QAM	135@67	21.76	16.26	0.0423
48	30	100	643332	3649.98	DFT-s-OFDM 16 QAM	1@1	21.41	15.91	0.0390
48	30	100	643332	3649.98	DFT-s-OFDM 16 QAM	1@271	21.33	15.83	0.0383
48	30	100	643332	3649.98	DFT-s-OFDM 64 QAM	135@67	20.27	14.77	0.0300
48	30	100	643332	3649.98	DFT-s-OFDM 64 QAM	1@1	19.95	14.45	0.0279
48	30	100	643332	3649.98	DFT-s-OFDM 64 QAM	1@271	19.79	14.29	0.0269
48	30	100	643332	3649.98	DFT-s-OFDM 256 QAM	135@67	18.38	12.88	0.0194
48	30	100	643332	3649.98	DFT-s-OFDM 256 QAM	1@1	17.80	12.30	0.0170
48	30	100	643332	3649.98	DFT-s-OFDM 256 QAM	1@271	17.76	12.26	0.0168
48	30	100	643332	3649.98	CP-OFDM QPSK	137@68	21.22	15.72	0.0373
48	30	100	643332	3649.98	CP-OFDM QPSK	1@1	20.79	15.29	0.0338
48	30	100	643332	3649.98	CP-OFDM QPSK	1@271	20.76	15.26	0.0336



For Ant9:

Transmitter Conducted Output Power And EIRP, (G_T - L_c)=-8.5dB

NR Band	SCS	BandWidth	Arfcn	Freq(MHz)	Modulation	RB	Conducted Power(dBm)	EIRP(dBm)	EIRP(W)
48	30	100	640000	3600	DFT-s-OFDM PI/2 BPSK	135@67	22.69	14.19	0.0262
48	30	100	640000	3600	DFT-s-OFDM PI/2 BPSK	1@1	22.44	13.94	0.0248
48	30	100	640000	3600	DFT-s-OFDM PI/2 BPSK	1@271	22.64	14.14	0.0259
48	30	100	640000	3600	DFT-s-OFDM QPSK	135@67	22.71	14.21	0.0264
48	30	100	640000	3600	DFT-s-OFDM QPSK	1@1	22.44	13.94	0.0248
48	30	100	640000	3600	DFT-s-OFDM QPSK	1@271	22.61	14.11	0.0258
48	30	100	640000	3600	DFT-s-OFDM 16 QAM	135@67	21.74	13.24	0.0211
48	30	100	640000	3600	DFT-s-OFDM 16 QAM	1@1	21.41	12.91	0.0195
48	30	100	640000	3600	DFT-s-OFDM 16 QAM	1@271	21.74	13.24	0.0211
48	30	100	640000	3600	DFT-s-OFDM 64 QAM	135@67	20.25	11.75	0.0150
48	30	100	640000	3600	DFT-s-OFDM 64 QAM	1@1	20.09	11.59	0.0144
48	30	100	640000	3600	DFT-s-OFDM 64 QAM	1@271	20.33	11.83	0.0152
48	30	100	640000	3600	DFT-s-OFDM 256 QAM	135@67	18.32	9.82	0.0096
48	30	100	640000	3600	DFT-s-OFDM 256 QAM	1@1	17.87	9.37	0.0086
48	30	100	640000	3600	DFT-s-OFDM 256 QAM	1@271	18.06	9.56	0.0090
48	30	100	640000	3600	CP-OFDM QPSK	137@68	21.17	12.67	0.0185
48	30	100	640000	3600	CP-OFDM QPSK	1@1	20.83	12.33	0.0171
48	30	100	640000	3600	CP-OFDM QPSK	1@271	21.17	12.67	0.0185
48	30	100	641666	3624.99	DFT-s-OFDM PI/2 BPSK	135@67	23.51	15.01	0.0317
48	30	100	641666	3624.99	DFT-s-OFDM PI/2 BPSK	1@1	22.57	14.07	0.0255
48	30	100	641666	3624.99	DFT-s-OFDM PI/2 BPSK	1@271	22.55	14.05	0.0254
48	30	100	641666	3624.99	DFT-s-OFDM QPSK	135@67	23.45	14.95	0.0313
48	30	100	641666	3624.99	DFT-s-OFDM QPSK	1@1	22.54	14.04	0.0254
48	30	100	641666	3624.99	DFT-s-OFDM QPSK	1@271	22.51	14.01	0.0252
48	30	100	641666	3624.99	DFT-s-OFDM 16 QAM	135@67	21.92	13.42	0.0220
48	30	100	641666	3624.99	DFT-s-OFDM 16 QAM	1@1	21.51	13.01	0.0200
48	30	100	641666	3624.99	DFT-s-OFDM 16 QAM	1@271	21.64	13.14	0.0206
48	30	100	641666	3624.99	DFT-s-OFDM 64 QAM	135@67	20.48	11.98	0.0158
48	30	100	641666	3624.99	DFT-s-OFDM 64 QAM	1@1	20.22	11.72	0.0149
48	30	100	641666	3624.99	DFT-s-OFDM 64 QAM	1@271	20.11	11.61	0.0145
48	30	100	641666	3624.99	DFT-s-OFDM 256 QAM	135@67	18.5	10	0.0100
48	30	100	641666	3624.99	DFT-s-OFDM 256 QAM	1@1	17.94	9.44	0.0088
48	30	100	641666	3624.99	DFT-s-OFDM 256 QAM	1@271	17.99	9.49	0.0089
48	30	100	641666	3624.99	CP-OFDM QPSK	137@68	21.38	12.88	0.0194
48	30	100	641666	3624.99	CP-OFDM QPSK	1@1	20.96	12.46	0.0176
48	30	100	641666	3624.99	CP-OFDM QPSK	1@271	21.01	12.51	0.0178
48	30	100	643332	3649.98	DFT-s-OFDM PI/2 BPSK	135@67	22.75	14.25	0.0266
48	30	100	643332	3649.98	DFT-s-OFDM PI/2 BPSK	1@1	22.56	14.06	0.0255
48	30	100	643332	3649.98	DFT-s-OFDM PI/2 BPSK	1@271	22.59	14.09	0.0256



48	30	100	643332	3649.98	DFT-s-OFDM QPSK	135@67	22.68	14.18	0.0262
48	30	100	643332	3649.98	DFT-s-OFDM QPSK	1@1	22.55	14.05	0.0254
48	30	100	643332	3649.98	DFT-s-OFDM QPSK	1@271	22.57	14.07	0.0255
48	30	100	643332	3649.98	DFT-s-OFDM 16 QAM	135@67	21.74	13.24	0.0211
48	30	100	643332	3649.98	DFT-s-OFDM 16 QAM	1@1	21.59	13.09	0.0204
48	30	100	643332	3649.98	DFT-s-OFDM 16 QAM	1@271	21.64	13.14	0.0206
48	30	100	643332	3649.98	DFT-s-OFDM 64 QAM	135@67	20.28	11.78	0.0151
48	30	100	643332	3649.98	DFT-s-OFDM 64 QAM	1@1	20.14	11.64	0.0146
48	30	100	643332	3649.98	DFT-s-OFDM 64 QAM	1@271	20.14	11.64	0.0146
48	30	100	643332	3649.98	DFT-s-OFDM 256 QAM	135@67	18.34	9.84	0.0096
48	30	100	643332	3649.98	DFT-s-OFDM 256 QAM	1@1	18	9.5	0.0089
48	30	100	643332	3649.98	DFT-s-OFDM 256 QAM	1@271	18.05	9.55	0.0090
48	30	100	643332	3649.98	CP-OFDM QPSK	137@68	21.19	12.69	0.0186
48	30	100	643332	3649.98	CP-OFDM QPSK	1@1	20.88	12.38	0.0173
48	30	100	643332	3649.98	CP-OFDM QPSK	1@271	21.04	12.54	0.0179
48	30	10	637000	3555	DFT-s-OFDM PI/2 BPSK	1@1	22.26	13.76	0.0238
48	30	10	637000	3555	DFT-s-OFDM QPSK	1@1	22.23	13.73	0.0236
48	30	10	637000	3555	DFT-s-OFDM 16 QAM	1@1	21.3	12.8	0.0191
48	30	10	641666	3624.99	DFT-s-OFDM PI/2 BPSK	1@1	22.84	14.34	0.0272
48	30	10	641666	3624.99	DFT-s-OFDM QPSK	1@1	22.85	14.35	0.0272
48	30	10	641666	3624.99	DFT-s-OFDM 16 QAM	1@1	21.92	13.42	0.0220
48	30	10	646332	3694.98	DFT-s-OFDM PI/2 BPSK	1@1	22.65	14.15	0.0260
48	30	10	646332	3694.98	DFT-s-OFDM QPSK	1@1	22.71	14.21	0.0264
48	30	10	646332	3694.98	DFT-s-OFDM 16 QAM	1@1	21.78	13.28	0.0213
48	30	15	637168	3557.52	DFT-s-OFDM PI/2 BPSK	1@1	22.33	13.83	0.0242
48	30	15	637168	3557.52	DFT-s-OFDM QPSK	1@1	22.31	13.81	0.0240
48	30	15	637168	3557.52	DFT-s-OFDM 16 QAM	1@1	21.34	12.84	0.0192
48	30	15	641666	3624.99	DFT-s-OFDM PI/2 BPSK	1@1	22.86	14.36	0.0273
48	30	15	641666	3624.99	DFT-s-OFDM QPSK	1@1	22.88	14.38	0.0274
48	30	15	641666	3624.99	DFT-s-OFDM 16 QAM	1@1	22	13.5	0.0224
48	30	15	646166	3692.49	DFT-s-OFDM PI/2 BPSK	1@1	22.67	14.17	0.0261
48	30	15	646166	3692.49	DFT-s-OFDM QPSK	1@1	22.67	14.17	0.0261
48	30	15	646166	3692.49	DFT-s-OFDM 16 QAM	1@1	21.71	13.21	0.0209
48	30	20	637334	3560.01	DFT-s-OFDM PI/2 BPSK	1@1	22.35	13.85	0.0243
48	30	20	637334	3560.01	DFT-s-OFDM QPSK	1@1	22.39	13.89	0.0245
48	30	20	637334	3560.01	DFT-s-OFDM 16 QAM	1@1	21.4	12.9	0.0195
48	30	20	641666	3624.99	DFT-s-OFDM PI/2 BPSK	1@1	22.89	14.39	0.0275
48	30	20	641666	3624.99	DFT-s-OFDM QPSK	1@1	22.89	14.39	0.0275
48	30	20	641666	3624.99	DFT-s-OFDM 16 QAM	1@1	21.94	13.44	0.0221
48	30	20	646000	3690	DFT-s-OFDM PI/2 BPSK	1@1	22.59	14.09	0.0256
48	30	20	646000	3690	DFT-s-OFDM QPSK	1@1	22.66	14.16	0.0261
48	30	20	646000	3690	DFT-s-OFDM 16 QAM	1@1	21.67	13.17	0.0207



48	30	30	637668	3565.02	DFT-s-OFDM PI/2 BPSK	1@1	22.37	13.87	0.0244
48	30	30	637668	3565.02	DFT-s-OFDM QPSK	1@1	22.35	13.85	0.0243
48	30	30	637668	3565.02	DFT-s-OFDM 16 QAM	1@1	21.4	12.9	0.0195
48	30	30	641666	3624.99	DFT-s-OFDM PI/2 BPSK	1@1	22.82	14.32	0.0270
48	30	30	641666	3624.99	DFT-s-OFDM QPSK	1@1	22.86	14.36	0.0273
48	30	30	641666	3624.99	DFT-s-OFDM 16 QAM	1@1	21.87	13.37	0.0217
48	30	30	645666	3684.99	DFT-s-OFDM PI/2 BPSK	1@1	22.76	14.26	0.0267
48	30	30	645666	3684.99	DFT-s-OFDM QPSK	1@1	22.78	14.28	0.0268
48	30	30	645666	3684.99	DFT-s-OFDM 16 QAM	1@1	21.79	13.29	0.0213
48	30	40	638000	3570	DFT-s-OFDM PI/2 BPSK	1@1	22.51	14.01	0.0252
48	30	40	638000	3570	DFT-s-OFDM QPSK	1@1	22.52	14.02	0.0252
48	30	40	638000	3570	DFT-s-OFDM 16 QAM	1@1	21.53	13.03	0.0201
48	30	40	641666	3624.99	DFT-s-OFDM PI/2 BPSK	1@1	22.74	14.24	0.0265
48	30	40	641666	3624.99	DFT-s-OFDM QPSK	1@1	22.72	14.22	0.0264
48	30	40	641666	3624.99	DFT-s-OFDM 16 QAM	1@1	21.76	13.26	0.0212
48	30	40	645332	3679.98	DFT-s-OFDM PI/2 BPSK	1@1	22.67	14.17	0.0261
48	30	40	645332	3679.98	DFT-s-OFDM QPSK	1@1	22.71	14.21	0.0264
48	30	40	645332	3679.98	DFT-s-OFDM 16 QAM	1@1	21.74	13.24	0.0211
48	30	50	638334	3575.01	DFT-s-OFDM PI/2 BPSK	1@1	22.44	13.94	0.0248
48	30	50	638334	3575.01	DFT-s-OFDM QPSK	1@1	22.39	13.89	0.0245
48	30	50	638334	3575.01	DFT-s-OFDM 16 QAM	1@1	21.49	12.99	0.0199
48	30	50	641666	3624.99	DFT-s-OFDM PI/2 BPSK	1@1	22.64	14.14	0.0259
48	30	50	641666	3624.99	DFT-s-OFDM QPSK	1@1	22.68	14.18	0.0262
48	30	50	641666	3624.99	DFT-s-OFDM 16 QAM	1@1	21.77	13.27	0.0212
48	30	50	645000	3675	DFT-s-OFDM PI/2 BPSK	1@1	22.58	14.08	0.0256
48	30	50	645000	3675	DFT-s-OFDM QPSK	1@1	22.6	14.1	0.0257
48	30	50	645000	3675	DFT-s-OFDM 16 QAM	1@1	21.62	13.12	0.0205
48	30	60	638668	3580.02	DFT-s-OFDM PI/2 BPSK	1@1	22.44	13.94	0.0248
48	30	60	638668	3580.02	DFT-s-OFDM QPSK	1@1	22.45	13.95	0.0248
48	30	60	638668	3580.02	DFT-s-OFDM 16 QAM	1@1	21.47	12.97	0.0198
48	30	60	641666	3624.99	DFT-s-OFDM PI/2 BPSK	1@1	22.56	14.06	0.0255
48	30	60	641666	3624.99	DFT-s-OFDM QPSK	1@1	22.58	14.08	0.0256
48	30	60	641666	3624.99	DFT-s-OFDM 16 QAM	1@1	21.62	13.12	0.0205
48	30	60	644666	3669.99	DFT-s-OFDM PI/2 BPSK	1@1	22.63	14.13	0.0259
48	30	60	644666	3669.99	DFT-s-OFDM QPSK	1@1	22.61	14.11	0.0258
48	30	60	644666	3669.99	DFT-s-OFDM 16 QAM	1@1	21.64	13.14	0.0206
48	30	70	639000	3585	DFT-s-OFDM PI/2 BPSK	1@1	22.43	13.93	0.0247
48	30	70	639000	3585	DFT-s-OFDM QPSK	1@1	22.37	13.87	0.0244
48	30	70	639000	3585	DFT-s-OFDM 16 QAM	1@1	21.44	12.94	0.0197
48	30	70	641666	3624.99	DFT-s-OFDM PI/2 BPSK	1@1	22.55	14.05	0.0254
48	30	70	641666	3624.99	DFT-s-OFDM QPSK	1@1	22.57	14.07	0.0255
48	30	70	641666	3624.99	DFT-s-OFDM 16 QAM	1@1	21.6	13.1	0.0204



48	30	70	644332	3664.98	DFT-s-OFDM PI/2 BPSK	1@1	22.82	14.32	0.0270
48	30	70	644332	3664.98	DFT-s-OFDM QPSK	1@1	22.79	14.29	0.0269
48	30	70	644332	3664.98	DFT-s-OFDM 16 QAM	1@1	21.83	13.33	0.0215
48	30	80	639334	3590.01	DFT-s-OFDM PI/2 BPSK	1@1	22.48	13.98	0.0250
48	30	80	639334	3590.01	DFT-s-OFDM QPSK	1@1	22.41	13.91	0.0246
48	30	80	639334	3590.01	DFT-s-OFDM 16 QAM	1@1	21.49	12.99	0.0199
48	30	80	641666	3624.99	DFT-s-OFDM PI/2 BPSK	1@1	22.63	14.13	0.0259
48	30	80	641666	3624.99	DFT-s-OFDM QPSK	1@1	22.56	14.06	0.0255
48	30	80	641666	3624.99	DFT-s-OFDM 16 QAM	1@1	21.6	13.1	0.0204
48	30	80	644000	3660	DFT-s-OFDM PI/2 BPSK	1@1	22.76	14.26	0.0267
48	30	80	644000	3660	DFT-s-OFDM QPSK	1@1	22.74	14.24	0.0265
48	30	80	644000	3660	DFT-s-OFDM 16 QAM	1@1	21.8	13.3	0.0214
48	30	90	639668	3595.02	DFT-s-OFDM PI/2 BPSK	1@1	22.39	13.89	0.0245
48	30	90	639668	3595.02	DFT-s-OFDM QPSK	1@1	22.42	13.92	0.0247
48	30	90	639668	3595.02	DFT-s-OFDM 16 QAM	1@1	21.47	12.97	0.0198
48	30	90	641666	3624.99	DFT-s-OFDM PI/2 BPSK	1@1	22.55	14.05	0.0254
48	30	90	641666	3624.99	DFT-s-OFDM QPSK	1@1	22.51	14.01	0.0252
48	30	90	641666	3624.99	DFT-s-OFDM 16 QAM	1@1	21.57	13.07	0.0203
48	30	90	643666	3654.99	DFT-s-OFDM PI/2 BPSK	1@1	22.78	14.28	0.0268
48	30	90	643666	3654.99	DFT-s-OFDM QPSK	1@1	22.76	14.26	0.0267
48	30	90	643666	3654.99	DFT-s-OFDM 16 QAM	1@1	21.8	13.3	0.0214



Frequency Stability

NR Band	SCS (kHz)	Bandwidth (MHz)	Arfcn	Freq (MHz)	Modulation	RB	Deviation (ppm)	Verdict	Environment
48	30	20	641666	3624.99	DFT-s-OFDM QPSK	50@0	0.0052	PASS	NV
48	30	20	641666	3624.99	DFT-s-OFDM QPSK	50@0	-0.0069	PASS	LV
48	30	20	641666	3624.99	DFT-s-OFDM QPSK	50@0	-0.0042	PASS	HV
48	30	20	641666	3624.99	DFT-s-OFDM QPSK	50@0	0.0032	PASS	-30°C
48	30	20	641666	3624.99	DFT-s-OFDM QPSK	50@0	0.0082	PASS	-20°C
48	30	20	641666	3624.99	DFT-s-OFDM QPSK	50@0	-0.0034	PASS	-10°C
48	30	20	641666	3624.99	DFT-s-OFDM QPSK	50@0	-0.0047	PASS	0°C
48	30	20	641666	3624.99	DFT-s-OFDM QPSK	50@0	0.0058	PASS	10°C
48	30	20	641666	3624.99	DFT-s-OFDM QPSK	50@0	0.0066	PASS	20°C
48	30	20	641666	3624.99	DFT-s-OFDM QPSK	50@0	-0.0041	PASS	30°C
48	30	20	641666	3624.99	DFT-s-OFDM QPSK	50@0	0.0037	PASS	40°C
48	30	20	641666	3624.99	DFT-s-OFDM QPSK	50@0	-0.0042	PASS	50°C



Peak to Average Ratio

NR Band	SCS (kHz)	Bandwidth (MHz)	Arfcn	Freq (MHz)	Modulation	RB	Result (dB)	Limit (dB)	Verdict
48	30	20	641666	3624.99	DFT-s-OFDM PI/2 BPSK	50@0	4.51	13	PASS
48	30	20	641666	3624.99	DFT-s-OFDM PI/2 BPSK	1@0	4.37	13	PASS
48	30	20	641666	3624.99	DFT-s-OFDM QPSK	50@0	5.79	13	PASS
48	30	20	641666	3624.99	DFT-s-OFDM QPSK	1@0	5.82	13	PASS



N48(20M)_DFT-s-OFDM_PI_2-BPSK_Outer_Full_Mid_CH



N48(20M)_DFT-s-OFDM_PI_2-BPSK_Edge_1RB_Left_Mid_CH



N48(20M)_DFT-s-OFDM_QPSK_Outer_Full_Mid_CH



N48(20M)_DFT-s-OFDM_QPSK_Edge_1RB_Left_Mid_CH





Occupied Bandwidth

NR Band	SCS (kHz)	Bandwidth (MHz)	Arfcn	Freq (MHz)	Modulation	RB	OBW (MHz)	26dB BW (MHz)
48	30	10	637000	3555.0	CP-OFDM QPSK	24@0	8.553	9.226
48	30	10	637000	3555.0	CP-OFDM 16 QAM	24@0	8.5778	9.137
48	30	10	637000	3555.0	CP-OFDM 64 QAM	24@0	8.5779	9.171
48	30	10	637000	3555.0	CP-OFDM 256 QAM	24@0	8.5876	9.169
48	30	10	641666	3624.99	CP-OFDM QPSK	24@0	8.5621	9.119
48	30	10	641666	3624.99	CP-OFDM 16 QAM	24@0	8.5552	9.125
48	30	10	641666	3624.99	CP-OFDM 64 QAM	24@0	8.5902	9.258
48	30	10	641666	3624.99	CP-OFDM 256 QAM	24@0	8.5522	9.104
48	30	10	646332	3694.98	CP-OFDM QPSK	24@0	8.5531	9.274
48	30	10	646332	3694.98	CP-OFDM 16 QAM	24@0	8.5694	9.16
48	30	10	646332	3694.98	CP-OFDM 64 QAM	24@0	8.5649	9.158
48	30	10	646332	3694.98	CP-OFDM 256 QAM	24@0	8.5484	9.073
48	30	15	637168	3557.52	CP-OFDM QPSK	38@0	13.544	14.17
48	30	15	637168	3557.52	CP-OFDM 16 QAM	38@0	13.575	14.24
48	30	15	637168	3557.52	CP-OFDM 64 QAM	38@0	13.61	14.17
48	30	15	637168	3557.52	CP-OFDM 256 QAM	38@0	13.572	14.36
48	30	15	641666	3624.99	CP-OFDM QPSK	38@0	13.535	14.32
48	30	15	641666	3624.99	CP-OFDM 16 QAM	38@0	13.576	14.5
48	30	15	641666	3624.99	CP-OFDM 64 QAM	38@0	13.604	14.11
48	30	15	641666	3624.99	CP-OFDM 256 QAM	38@0	13.525	14.26
48	30	15	646166	3692.49	CP-OFDM QPSK	38@0	13.547	14.24
48	30	15	646166	3692.49	CP-OFDM 16 QAM	38@0	13.557	14.27
48	30	15	646166	3692.49	CP-OFDM 64 QAM	38@0	13.535	14.28
48	30	15	646166	3692.49	CP-OFDM 256 QAM	38@0	13.52	14.27
48	30	20	637334	3560.01	CP-OFDM QPSK	51@0	18.237	19.02
48	30	20	637334	3560.01	CP-OFDM 16 QAM	51@0	18.195	19.02
48	30	20	637334	3560.01	CP-OFDM 64 QAM	51@0	18.178	18.87
48	30	20	637334	3560.01	CP-OFDM 256 QAM	51@0	18.194	18.95
48	30	20	641666	3624.99	CP-OFDM QPSK	51@0	18.187	18.99
48	30	20	641666	3624.99	CP-OFDM 16 QAM	51@0	18.193	19.1



48	30	20	641666	3624.99	CP-OFDM 64 QAM	51@0	18.186	18.91
48	30	20	641666	3624.99	CP-OFDM 256 QAM	51@0	18.241	18.98
48	30	20	646000	3690.0	CP-OFDM QPSK	51@0	18.179	19.21
48	30	20	646000	3690.0	CP-OFDM 16 QAM	51@0	18.198	18.93
48	30	20	646000	3690.0	CP-OFDM 64 QAM	51@0	18.153	18.95
48	30	20	646000	3690.0	CP-OFDM 256 QAM	51@0	18.206	18.86
48	30	30	637668	3565.02	CP-OFDM QPSK	78@0	27.799	28.93
48	30	30	637668	3565.02	CP-OFDM 16 QAM	78@0	27.873	29.05
48	30	30	637668	3565.02	CP-OFDM 64 QAM	78@0	27.798	28.75
48	30	30	637668	3565.02	CP-OFDM 256 QAM	78@0	27.837	29.18
48	30	30	641666	3624.99	CP-OFDM QPSK	78@0	27.862	28.94
48	30	30	641666	3624.99	CP-OFDM 16 QAM	78@0	27.868	28.92
48	30	30	641666	3624.99	CP-OFDM 64 QAM	78@0	27.874	28.93
48	30	30	641666	3624.99	CP-OFDM 256 QAM	78@0	27.778	28.97
48	30	30	645666	3684.99	CP-OFDM QPSK	78@0	27.851	29.02
48	30	30	645666	3684.99	CP-OFDM 16 QAM	78@0	27.829	28.82
48	30	30	645666	3684.99	CP-OFDM 64 QAM	78@0	27.789	29.0
48	30	30	645666	3684.99	CP-OFDM 256 QAM	78@0	27.91	29.09
48	30	40	638000	3570.0	CP-OFDM QPSK	106@0	37.818	39.21
48	30	40	638000	3570.0	CP-OFDM 16 QAM	106@0	37.883	39.35
48	30	40	638000	3570.0	CP-OFDM 64 QAM	106@0	37.827	39.1
48	30	40	638000	3570.0	CP-OFDM 256 QAM	106@0	37.838	39.28
48	30	40	641666	3624.99	CP-OFDM QPSK	106@0	37.967	39.29
48	30	40	641666	3624.99	CP-OFDM 16 QAM	106@0	37.86	39.36
48	30	40	641666	3624.99	CP-OFDM 64 QAM	106@0	37.875	39.27
48	30	40	641666	3624.99	CP-OFDM 256 QAM	106@0	37.78	39.24
48	30	40	645332	3679.98	CP-OFDM QPSK	106@0	37.877	39.14
48	30	40	645332	3679.98	CP-OFDM 16 QAM	106@0	37.83	39.55
48	30	40	645332	3679.98	CP-OFDM 64 QAM	106@0	37.876	39.18
48	30	40	645332	3679.98	CP-OFDM 256 QAM	106@0	37.678	39.18
48	30	50	638334	3575.01	CP-OFDM QPSK	133@0	47.352	49.0
48	30	50	638334	3575.01	CP-OFDM 16 QAM	133@0	47.488	49.18
48	30	50	638334	3575.01	CP-OFDM 64	133@0	47.533	49.06



					QAM			
48	30	50	638334	3575.01	CP-OFDM 256 QAM	133@0	47.567	49.14
48	30	50	641666	3624.99	CP-OFDM QPSK	133@0	47.345	48.96
48	30	50	641666	3624.99	CP-OFDM 16 QAM	133@0	47.359	49.1
48	30	50	641666	3624.99	CP-OFDM 64 QAM	133@0	47.443	49.01
48	30	50	641666	3624.99	CP-OFDM 256 QAM	133@0	47.558	48.99
48	30	50	645000	3675.0	CP-OFDM QPSK	133@0	47.568	49.1
48	30	50	645000	3675.0	CP-OFDM 16 QAM	133@0	47.396	49.05
48	30	50	645000	3675.0	CP-OFDM 64 QAM	133@0	47.455	49.18
48	30	50	645000	3675.0	CP-OFDM 256 QAM	133@0	47.448	48.98
48	30	60	638668	3580.02	CP-OFDM QPSK	162@0	57.755	59.71
48	30	60	638668	3580.02	CP-OFDM 16 QAM	162@0	57.862	59.76
48	30	60	638668	3580.02	CP-OFDM 64 QAM	162@0	57.794	59.72
48	30	60	638668	3580.02	CP-OFDM 256 QAM	162@0	57.849	59.7
48	30	60	641666	3624.99	CP-OFDM QPSK	162@0	57.833	59.77
48	30	60	641666	3624.99	CP-OFDM 16 QAM	162@0	57.756	59.65
48	30	60	641666	3624.99	CP-OFDM 64 QAM	162@0	57.844	59.75
48	30	60	641666	3624.99	CP-OFDM 256 QAM	162@0	57.688	59.67
48	30	60	644666	3669.99	CP-OFDM QPSK	162@0	57.728	59.71
48	30	60	644666	3669.99	CP-OFDM 16 QAM	162@0	57.687	59.67
48	30	60	644666	3669.99	CP-OFDM 64 QAM	162@0	57.822	59.74
48	30	60	644666	3669.99	CP-OFDM 256 QAM	162@0	57.88	59.75
48	30	70	639000	3585.0	CP-OFDM QPSK	189@0	67.324	69.71
48	30	70	639000	3585.0	CP-OFDM 16 QAM	189@0	67.566	69.53
48	30	70	639000	3585.0	CP-OFDM 64 QAM	189@0	67.534	69.66
48	30	70	639000	3585.0	CP-OFDM 256 QAM	189@0	67.312	69.69
48	30	70	641666	3624.99	CP-OFDM QPSK	189@0	67.283	69.69
48	30	70	641666	3624.99	CP-OFDM 16 QAM	189@0	67.448	69.72
48	30	70	641666	3624.99	CP-OFDM 64 QAM	189@0	67.514	69.7
48	30	70	641666	3624.99	CP-OFDM 256 QAM	189@0	67.439	69.7
48	30	70	644332	3664.98	CP-OFDM QPSK	189@0	67.244	69.77
48	30	70	644332	3664.98	CP-OFDM 16 QAM	189@0	67.422	69.7
48	30	70	644332	3664.98	CP-OFDM 64 QAM	189@0	67.569	69.77



48	30	70	644332	3664.98	CP-OFDM 256 QAM	189@0	67.549	69.71
48	30	80	639334	3590.01	CP-OFDM QPSK	217@0	77.468	79.96
48	30	80	639334	3590.01	CP-OFDM 16 QAM	217@0	77.418	79.88
48	30	80	639334	3590.01	CP-OFDM 64 QAM	217@0	77.576	79.93
48	30	80	639334	3590.01	CP-OFDM 256 QAM	217@0	77.45	79.86
48	30	80	641666	3624.99	CP-OFDM QPSK	217@0	77.449	79.88
48	30	80	641666	3624.99	CP-OFDM 16 QAM	217@0	77.464	80.02
48	30	80	641666	3624.99	CP-OFDM 64 QAM	217@0	77.502	79.97
48	30	80	641666	3624.99	CP-OFDM 256 QAM	217@0	77.503	79.92
48	30	80	644000	3660.0	CP-OFDM QPSK	217@0	77.399	79.89
48	30	80	644000	3660.0	CP-OFDM 16 QAM	217@0	77.669	79.99
48	30	80	644000	3660.0	CP-OFDM 64 QAM	217@0	77.431	79.92
48	30	80	644000	3660.0	CP-OFDM 256 QAM	217@0	77.412	79.93
48	30	90	639668	3595.02	CP-OFDM QPSK	245@0	87.375	90.26
48	30	90	639668	3595.02	CP-OFDM 16 QAM	245@0	87.479	90.18
48	30	90	639668	3595.02	CP-OFDM 64 QAM	245@0	87.519	90.28
48	30	90	639668	3595.02	CP-OFDM 256 QAM	245@0	87.436	90.42
48	30	90	641666	3624.99	CP-OFDM QPSK	245@0	87.424	90.22
48	30	90	641666	3624.99	CP-OFDM 16 QAM	245@0	87.498	90.25
48	30	90	641666	3624.99	CP-OFDM 64 QAM	245@0	87.548	90.26
48	30	90	641666	3624.99	CP-OFDM 256 QAM	245@0	87.402	90.21
48	30	90	643666	3654.99	CP-OFDM QPSK	245@0	87.473	90.18
48	30	90	643666	3654.99	CP-OFDM 16 QAM	245@0	87.506	90.16
48	30	90	643666	3654.99	CP-OFDM 64 QAM	245@0	87.474	90.22
48	30	90	643666	3654.99	CP-OFDM 256 QAM	245@0	87.251	90.25
48	30	100	640000	3600.0	CP-OFDM QPSK	273@0	97.443	100.5
48	30	100	640000	3600.0	CP-OFDM 16 QAM	273@0	97.349	100.4
48	30	100	640000	3600.0	CP-OFDM 64 QAM	273@0	97.331	100.4
48	30	100	640000	3600.0	CP-OFDM 256 QAM	273@0	97.343	100.6
48	30	100	641666	3624.99	CP-OFDM QPSK	273@0	97.404	100.6
48	30	100	641666	3624.99	CP-OFDM 16 QAM	273@0	97.406	100.5
48	30	100	641666	3624.99	CP-OFDM 64 QAM	273@0	97.316	100.5
48	30	100	641666	3624.99	CP-OFDM 256 QAM	273@0	97.376	100.5



					QAM			
48	30	100	643332	3649.98	CP-OFDM QPSK	273@0	97.229	100.4
48	30	100	643332	3649.98	CP-OFDM 16 QAM	273@0	97.453	100.5
48	30	100	643332	3649.98	CP-OFDM 64 QAM	273@0	97.405	100.5
48	30	100	643332	3649.98	CP-OFDM 256 QAM	273@0	97.192	100.4



N48(10M)_CP-OFDM_QPSK_Outer_Full_Low_CH

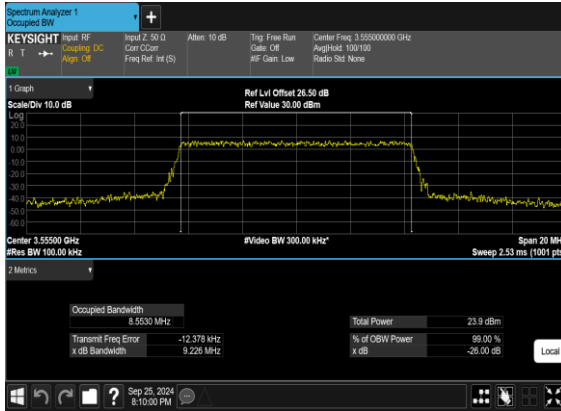

N48(10M)_CP-OFDM_16QAM_Outer_Full_Low_CH

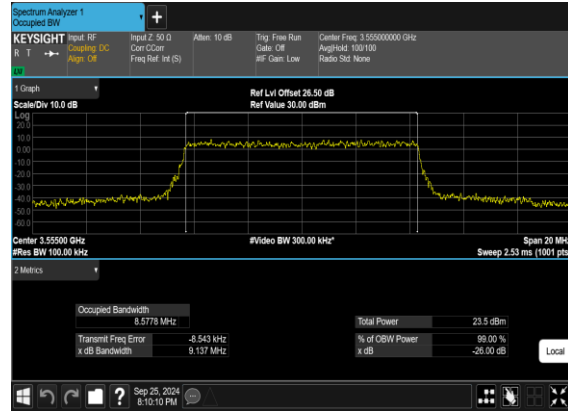

N48(10M)_CP-OFDM_64QAM_Outer_Full_Low_CH

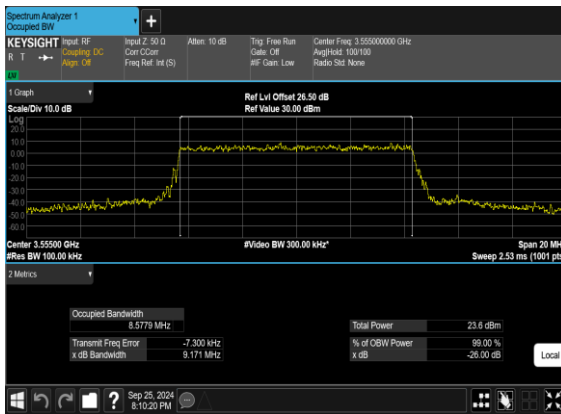

N48(10M)_CP-OFDM_256QAM_Outer_Full_Low_CH

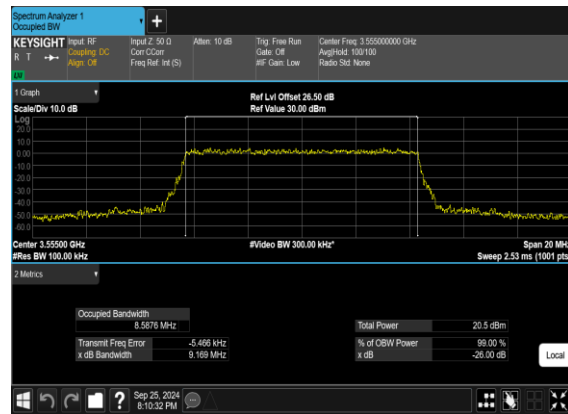



N48(10M)_CP-OFDM_QPSK_Outer_Full_Mid_CH

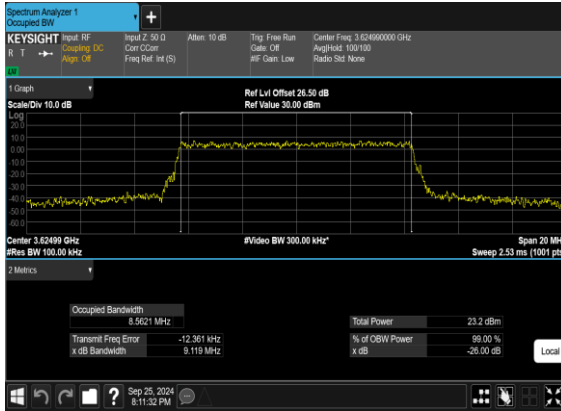

N48(10M)_CP-OFDM_16QAM_Outer_Full_Mid_CH

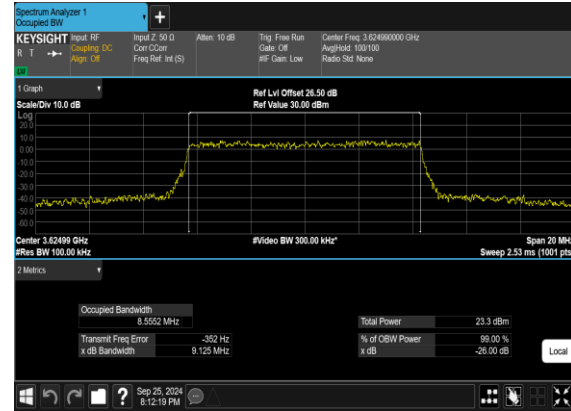

N48(10M)_CP-OFDM_64QAM_Outer_Full_Mid_CH



N48(10M)_CP-OFDM_256QAM_Outer_Full_Mid_CH

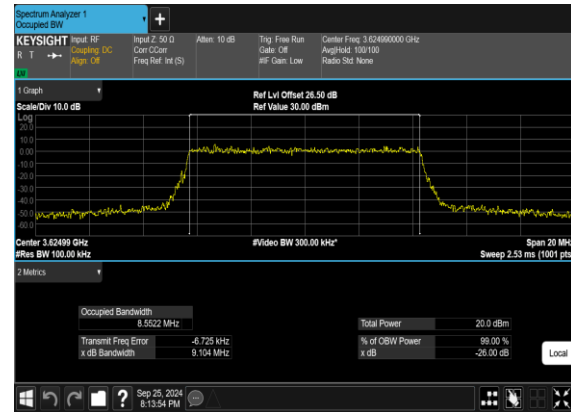



N48(10M)_CP-OFDM_QPSK_Outer_Full_High_CH

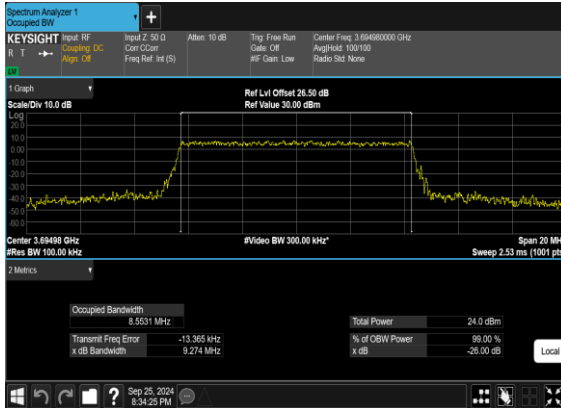

N48(10M)_CP-OFDM_16QAM_Outer_Full_High_CH

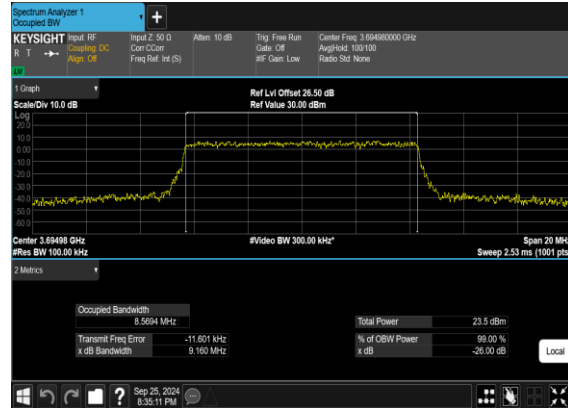

N48(10M)_CP-OFDM_64QAM_Outer_Full_High_CH

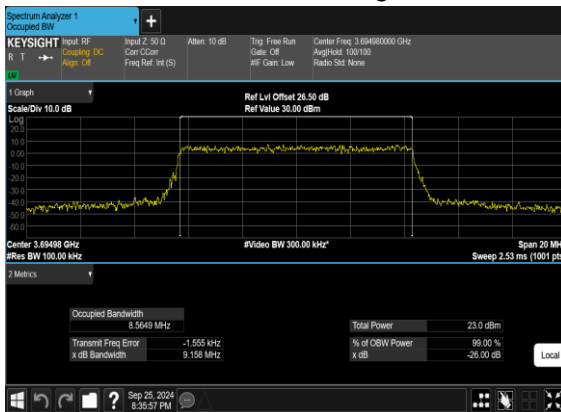

N48(10M)_CP-OFDM_256QAM_Outer_Full_High_CH

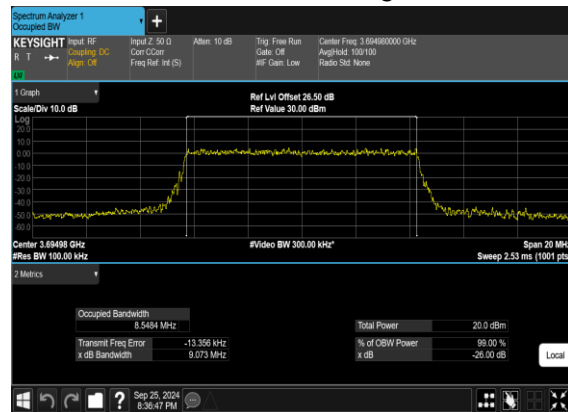



N48(15M)_CP-OFDM_QPSK_Outer_Full_Low_CH

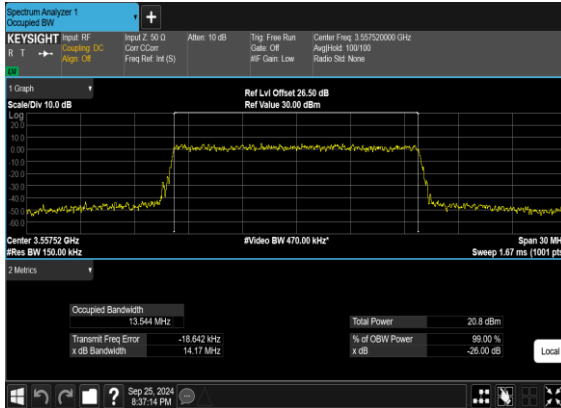

N48(15M)_CP-OFDM_16QAM_Outer_Full_Low_CH

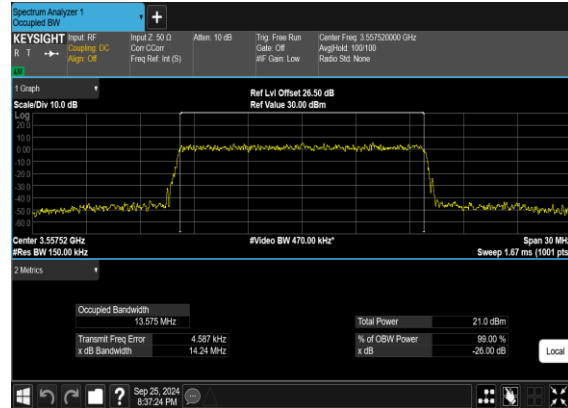

N48(15M)_CP-OFDM_64QAM_Outer_Full_Low_CH

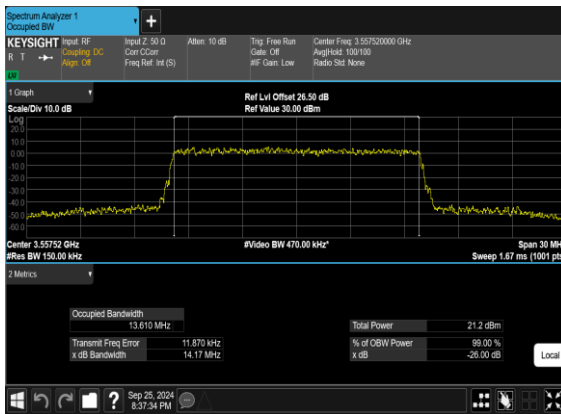

N48(15M)_CP-OFDM_256QAM_Outer_Full_Low_CH

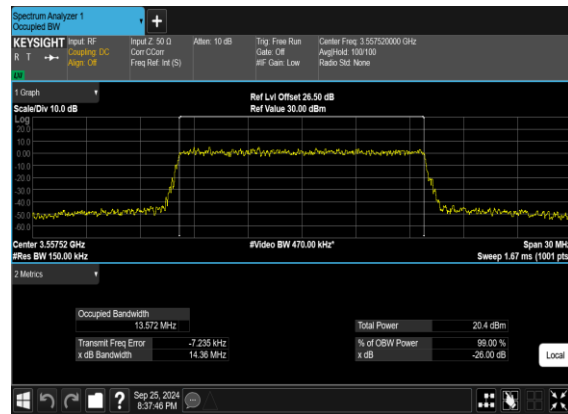



N48(15M)_CP-OFDM_QPSK_Outer_Full_Mid_CH

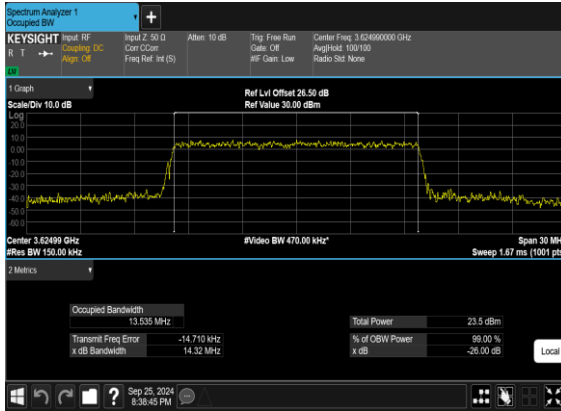

N48(15M)_CP-OFDM_16QAM_Outer_Full_Mid_CH

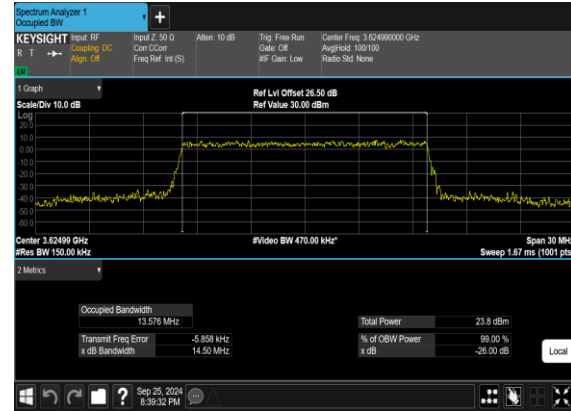

N48(15M)_CP-OFDM_64QAM_Outer_Full_Mid_CH

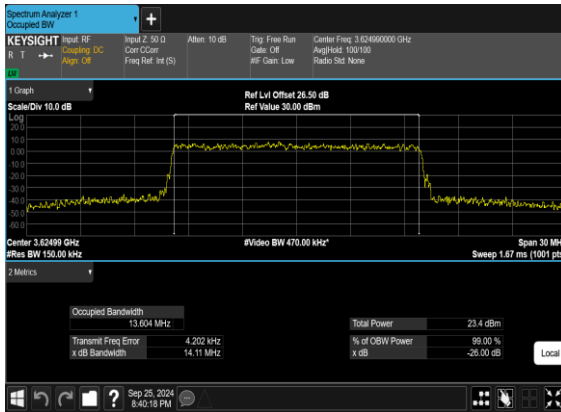

N48(15M)_CP-OFDM_256QAM_Outer_Full_Mid_CH

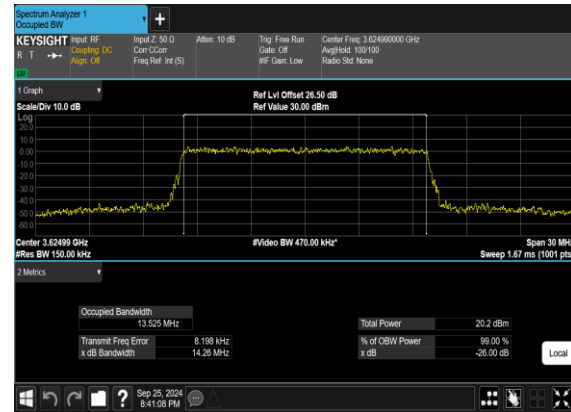



N48(15M)_CP-OFDM_QPSK_Outer_Full_High_CH

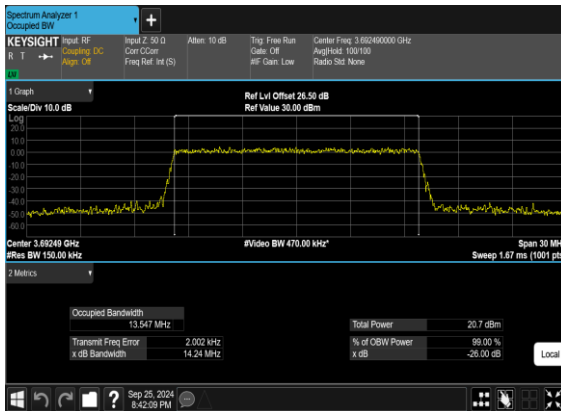

N48(15M)_CP-OFDM_16QAM_Outer_Full_High_CH

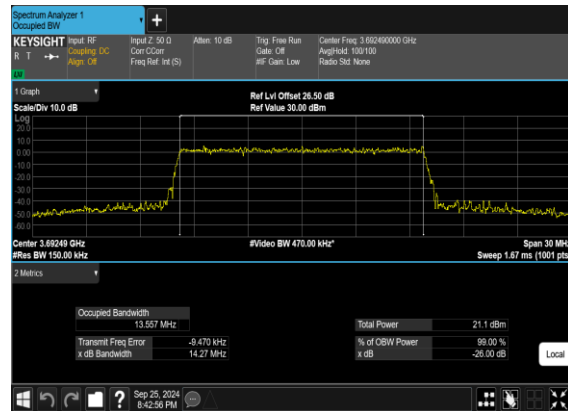

N48(15M)_CP-OFDM_64QAM_Outer_Full_High_CH

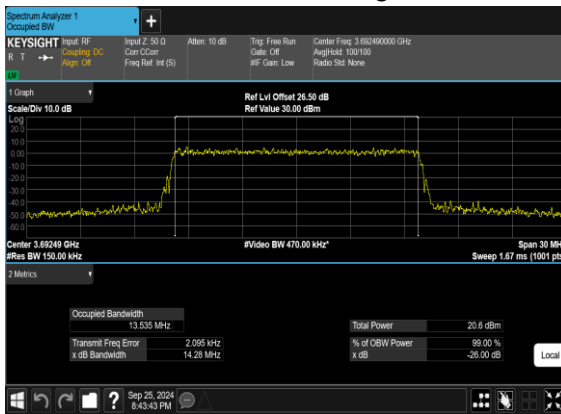

N48(15M)_CP-OFDM_256QAM_Outer_Full_High_CH

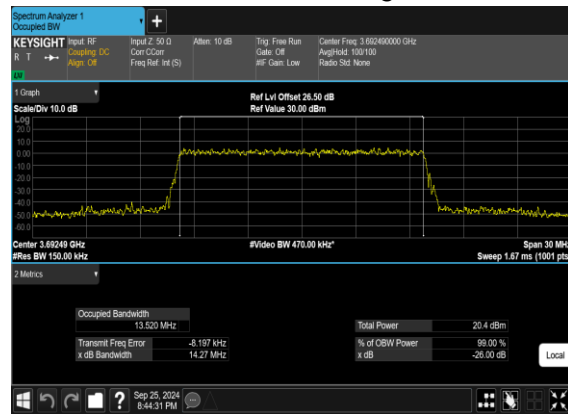



N48(20M)_CP-OFDM_QPSK_Outer_Full_Low_CH

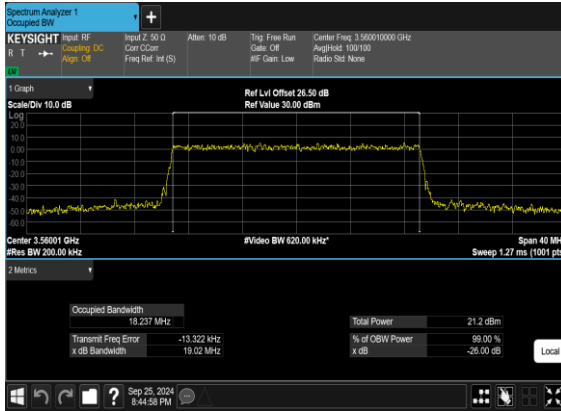

N48(20M)_CP-OFDM_16QAM_Outer_Full_Low_CH

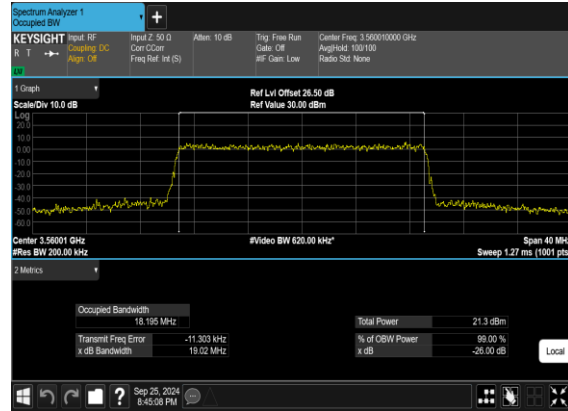

N48(20M)_CP-OFDM_64QAM_Outer_Full_Low_CH

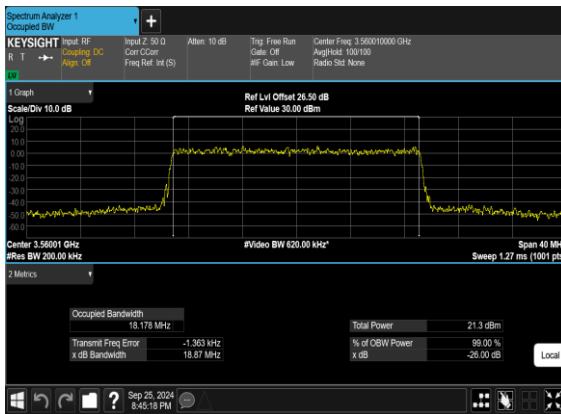

N48(20M)_CP-OFDM_256QAM_Outer_Full_Low_CH

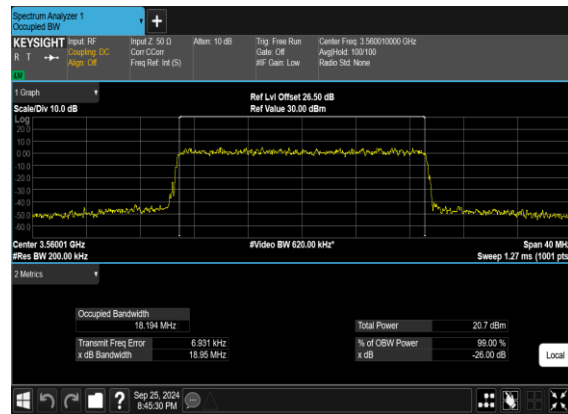



N48(20M)_CP-OFDM_QPSK_Outer_Full_Mid_CH

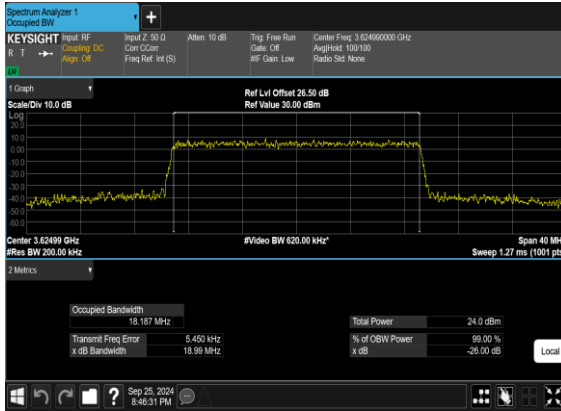

N48(20M)_CP-OFDM_16QAM_Outer_Full_Mid_CH

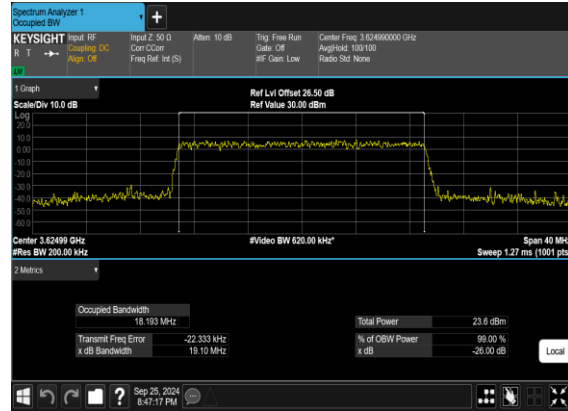

N48(20M)_CP-OFDM_64QAM_Outer_Full_Mid_CH

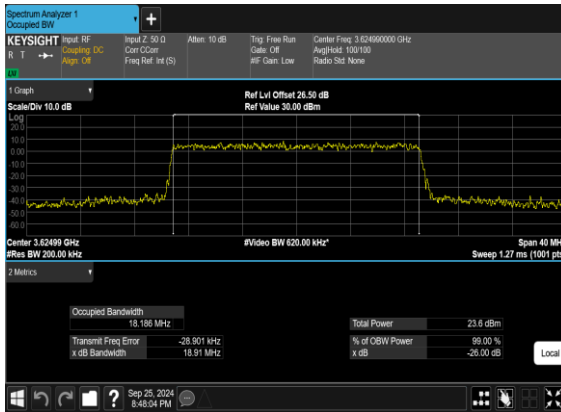

N48(20M)_CP-OFDM_256QAM_Outer_Full_Mid_CH

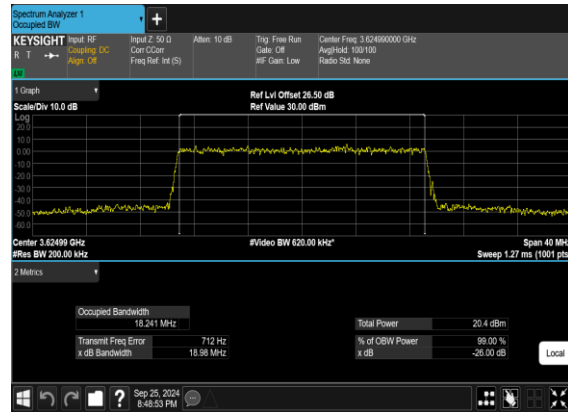



N48(20M)_CP-OFDM_QPSK_Outer_Full_High_CH

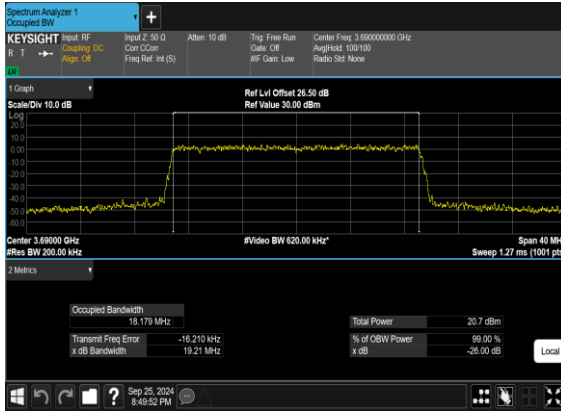

N48(20M)_CP-OFDM_16QAM_Outer_Full_High_CH

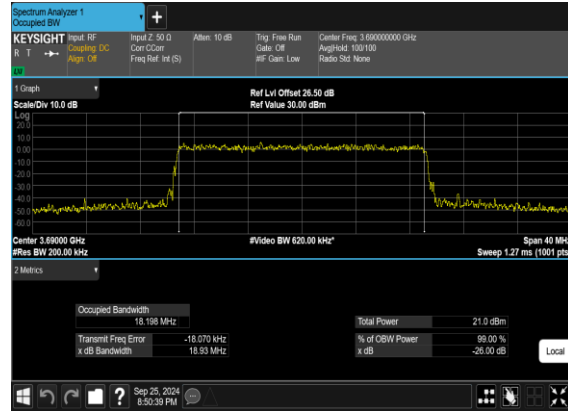

N48(20M)_CP-OFDM_64QAM_Outer_Full_High_CH

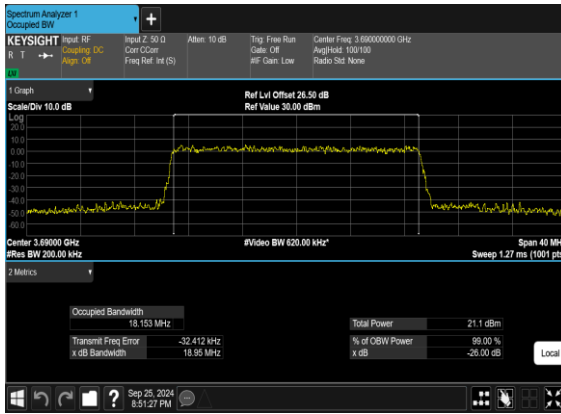

N48(20M)_CP-OFDM_256QAM_Outer_Full_High_CH

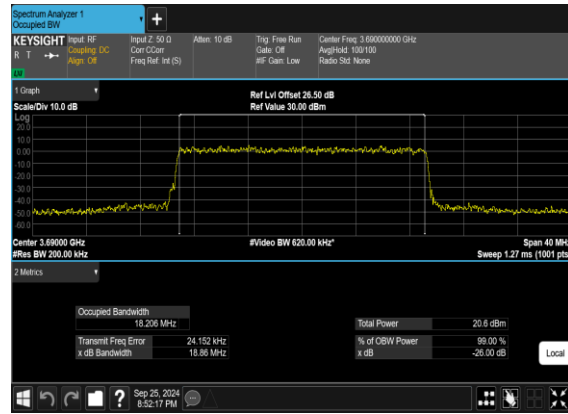



N48(30M)_CP-OFDM_QPSK_Outer_Full_Low_CH

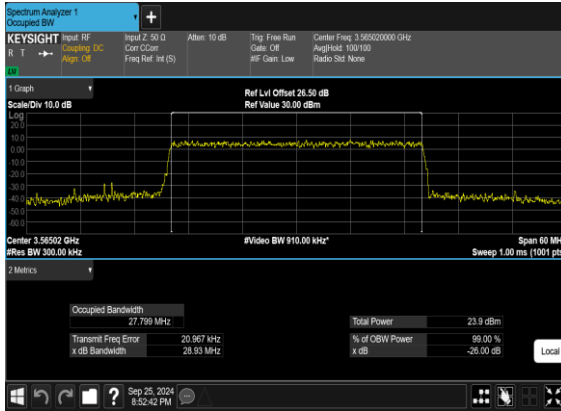

N48(30M)_CP-OFDM_16QAM_Outer_Full_Low_CH

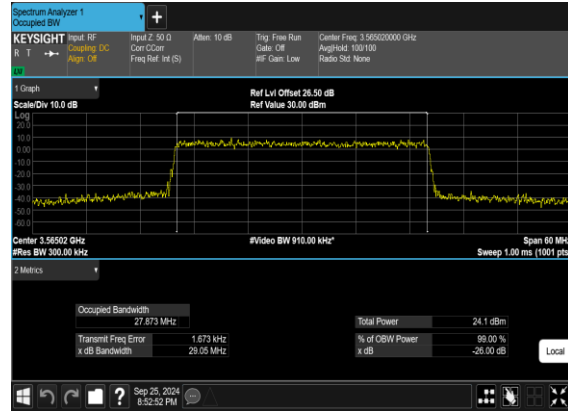

N48(30M)_CP-OFDM_64QAM_Outer_Full_Low_CH

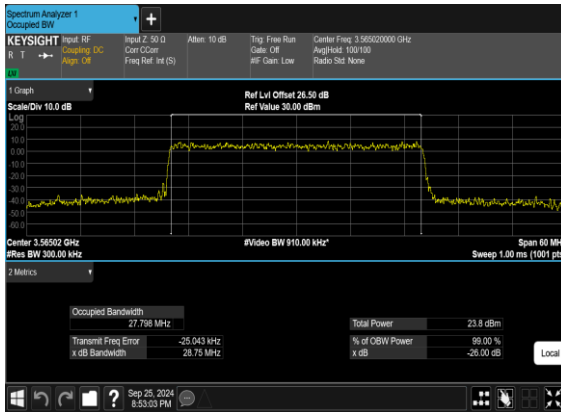

N48(30M)_CP-OFDM_256QAM_Outer_Full_Low_CH

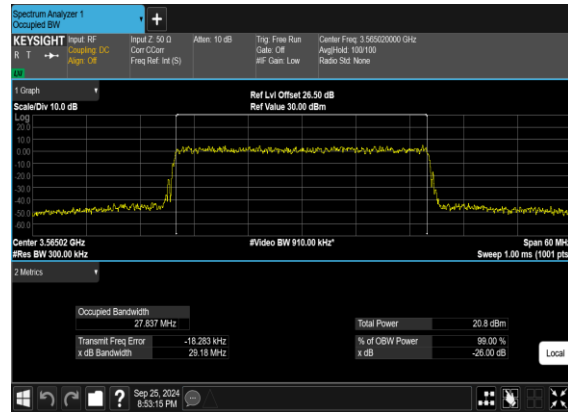



N48(30M)_CP-OFDM_QPSK_Outer_Full_Mid_CH

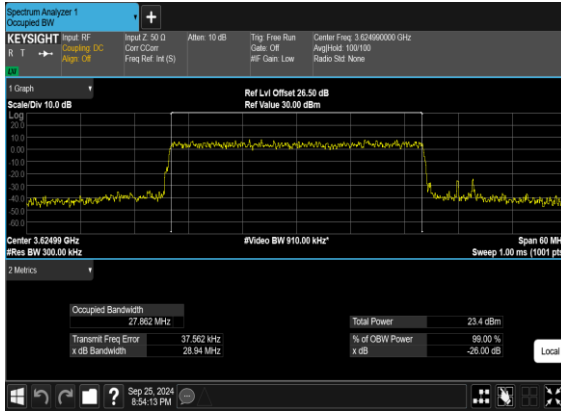

N48(30M)_CP-OFDM_16QAM_Outer_Full_Mid_CH

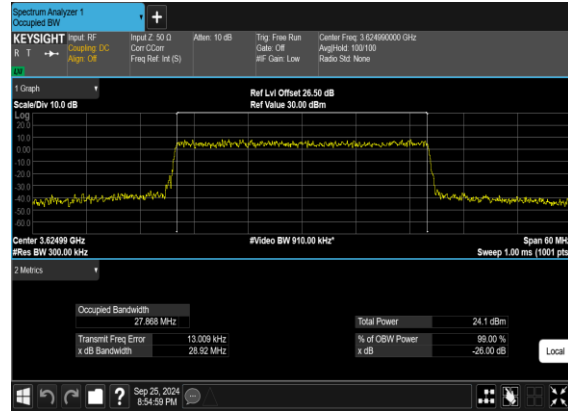

N48(30M)_CP-OFDM_64QAM_Outer_Full_Mid_CH

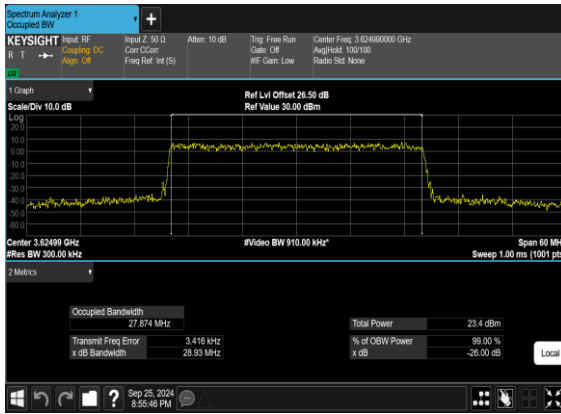

N48(30M)_CP-OFDM_256QAM_Outer_Full_Mid_CH

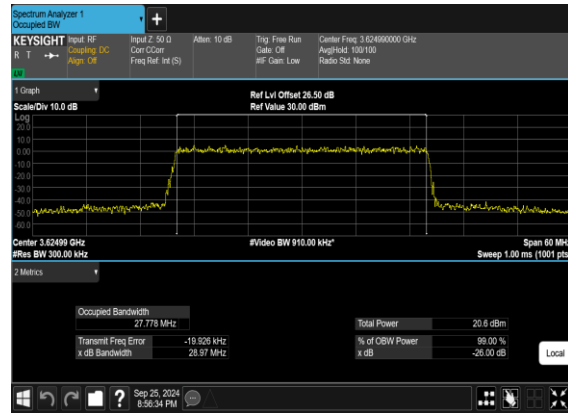



N48(30M)_CP-OFDM_QPSK_Outer_Full_High_CH

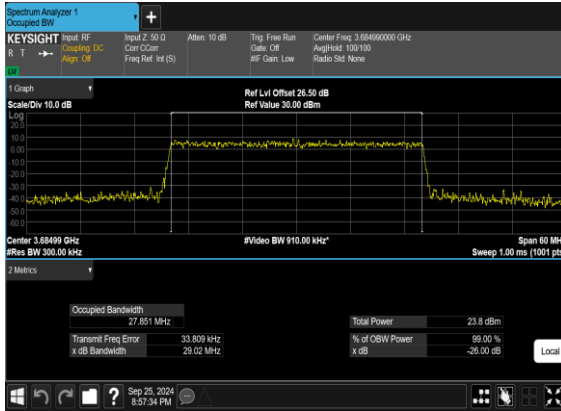

N48(30M)_CP-OFDM_16QAM_Outer_Full_High_CH

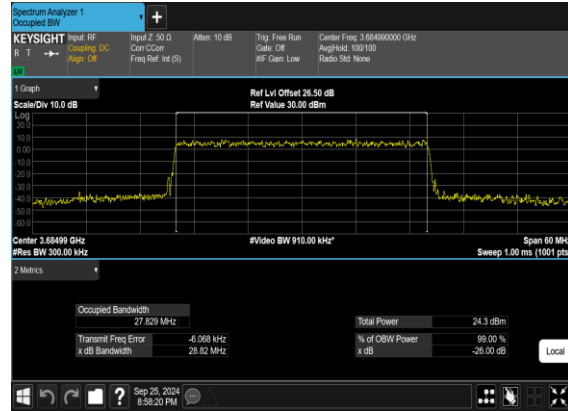

N48(30M)_CP-OFDM_64QAM_Outer_Full_High_CH

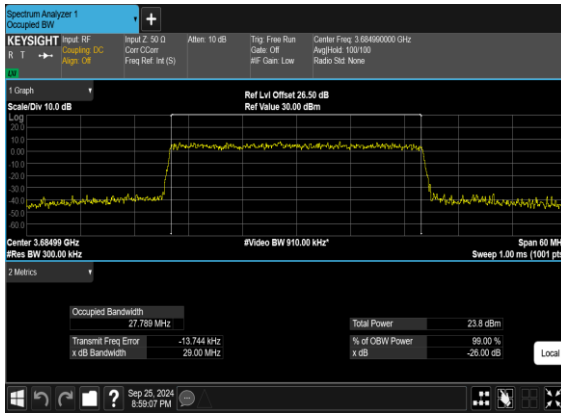

N48(30M)_CP-OFDM_256QAM_Outer_Full_High_CH

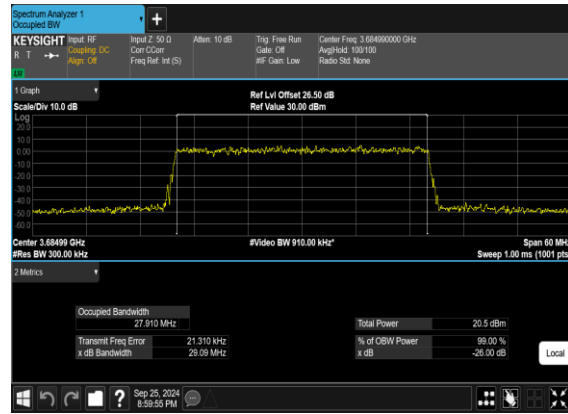



N48(40M)_CP-OFDM_QPSK_Outer_Full_Low_CH

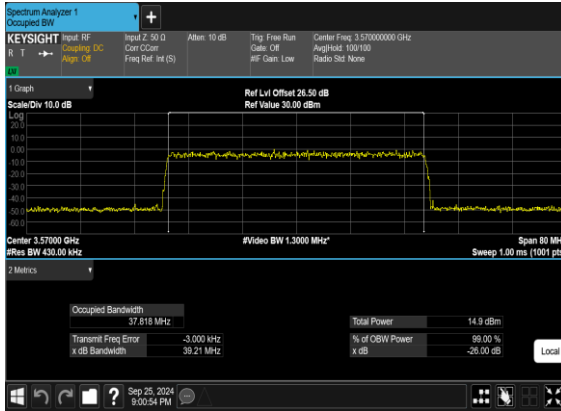

N48(40M)_CP-OFDM_16QAM_Outer_Full_Low_CH

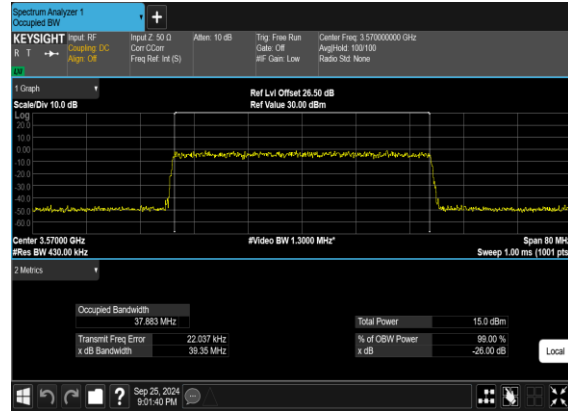

N48(40M)_CP-OFDM_64QAM_Outer_Full_Low_CH

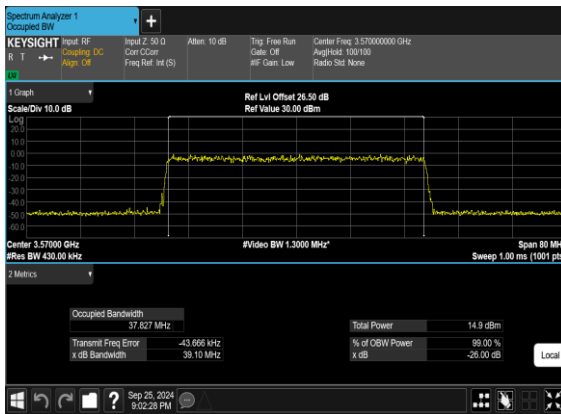

N48(40M)_CP-OFDM_256QAM_Outer_Full_Low_CH

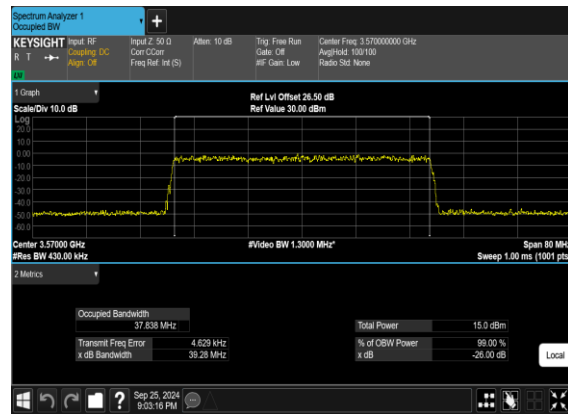



N48(40M)_CP-OFDM_QPSK_Outer_Full_Mid_CH

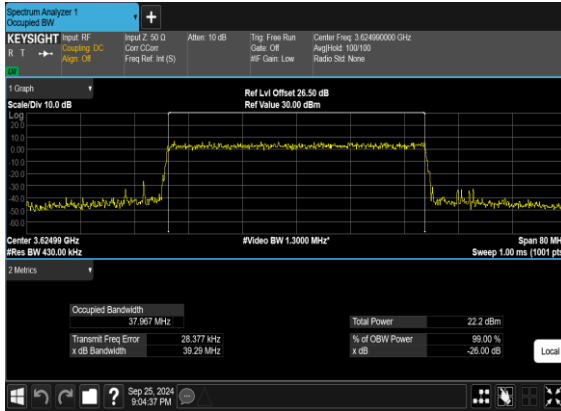

N48(40M)_CP-OFDM_16QAM_Outer_Full_Mid_CH

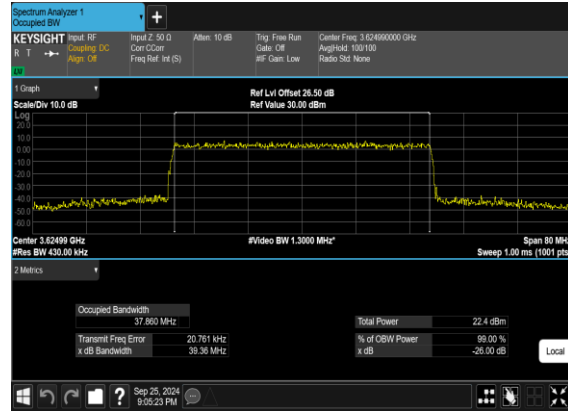

N48(40M)_CP-OFDM_64QAM_Outer_Full_Mid_CH

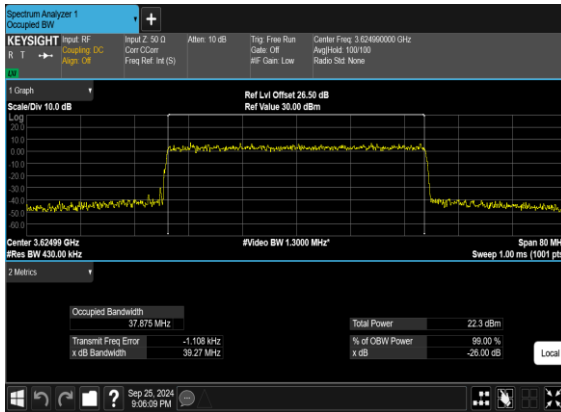

N48(40M)_CP-OFDM_256QAM_Outer_Full_Mid_CH

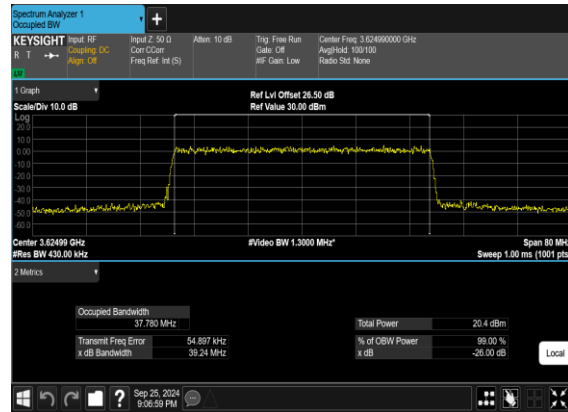



N48(40M)_CP-OFDM_QPSK_Outer_Full_High_CH

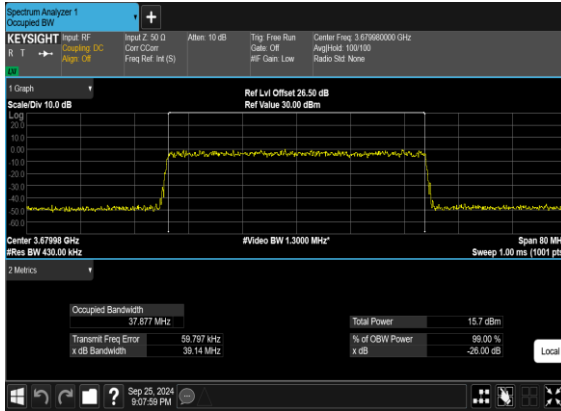

N48(40M)_CP-OFDM_16QAM_Outer_Full_High_CH

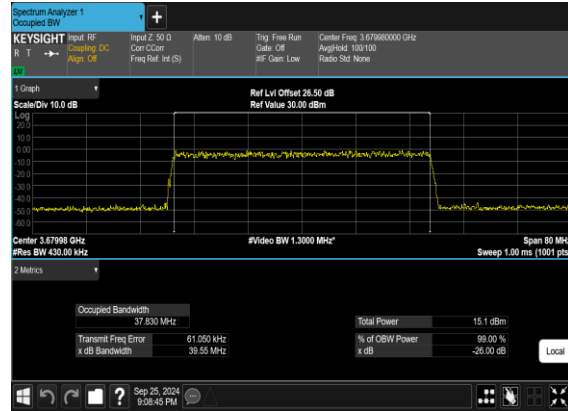

N48(40M)_CP-OFDM_64QAM_Outer_Full_High_CH

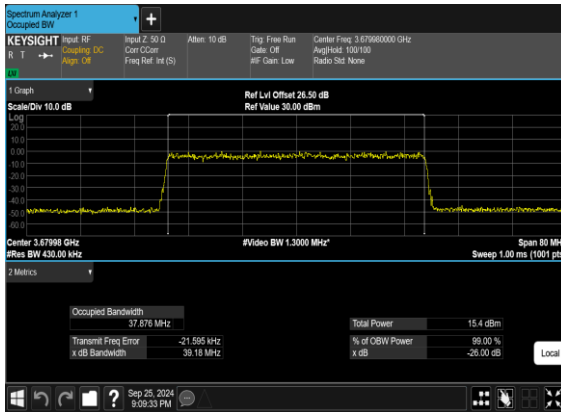

N48(40M)_CP-OFDM_256QAM_Outer_Full_High_CH

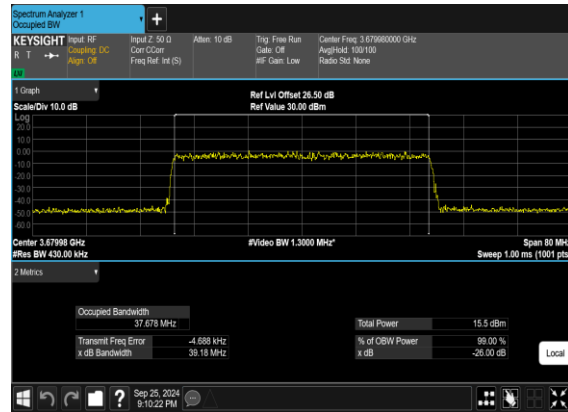



N48(50M)_CP-OFDM_QPSK_Outer_Full_Low_CH

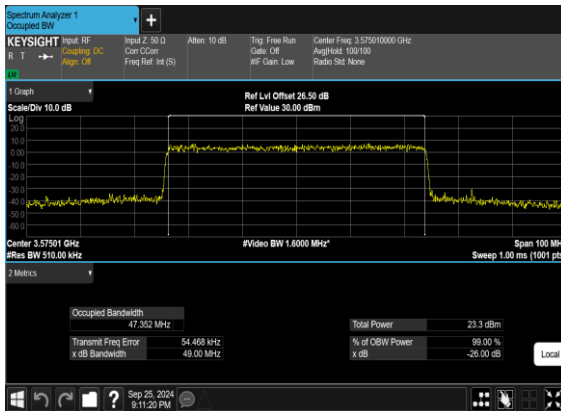

N48(50M)_CP-OFDM_16QAM_Outer_Full_Low_CH

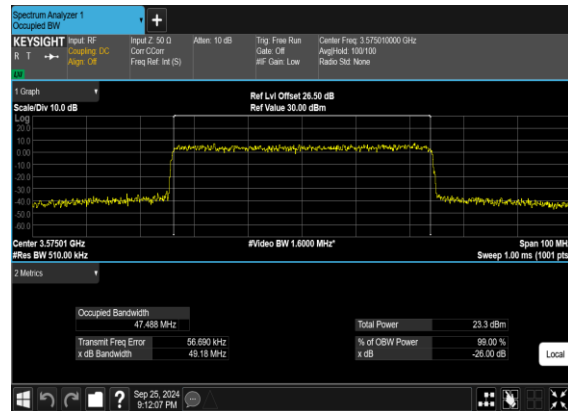

N48(50M)_CP-OFDM_64QAM_Outer_Full_Low_CH

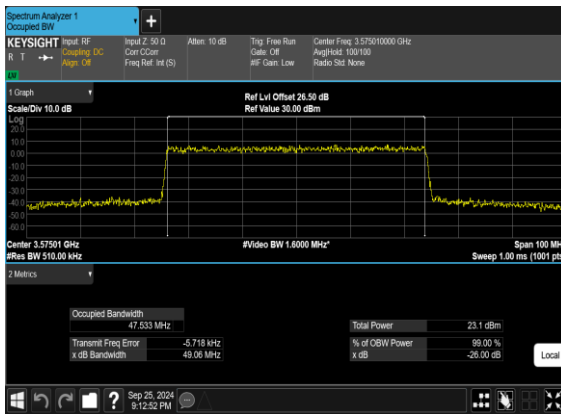

N48(50M)_CP-OFDM_256QAM_Outer_Full_Low_CH

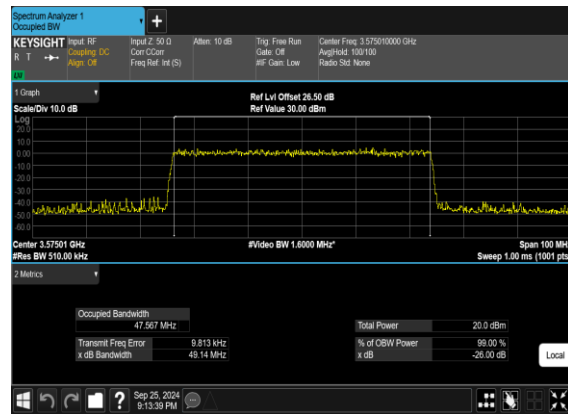



N48(50M)_CP-OFDM_QPSK_Outer_Full_Mid_CH

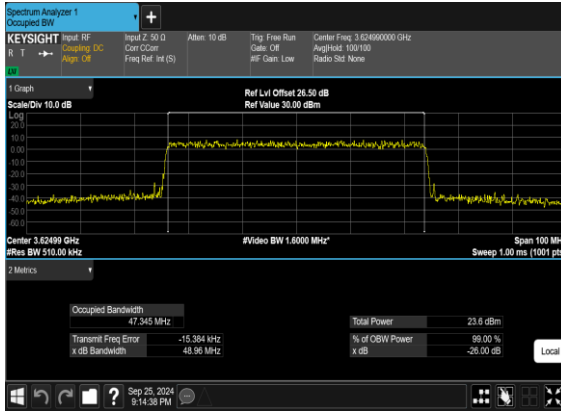

N48(50M)_CP-OFDM_16QAM_Outer_Full_Mid_CH

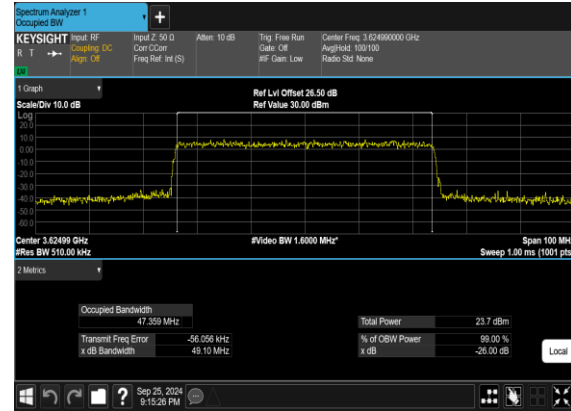

N48(50M)_CP-OFDM_64QAM_Outer_Full_Mid_CH

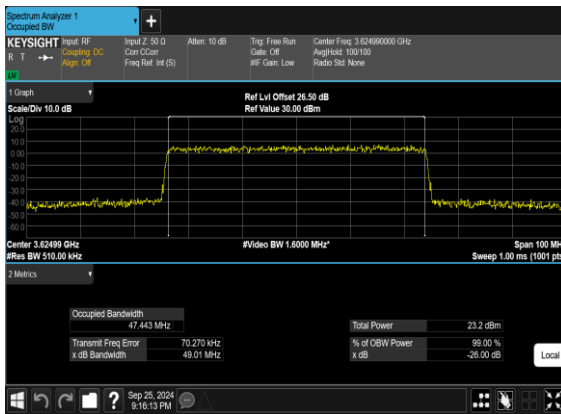

N48(50M)_CP-OFDM_256QAM_Outer_Full_Mid_CH

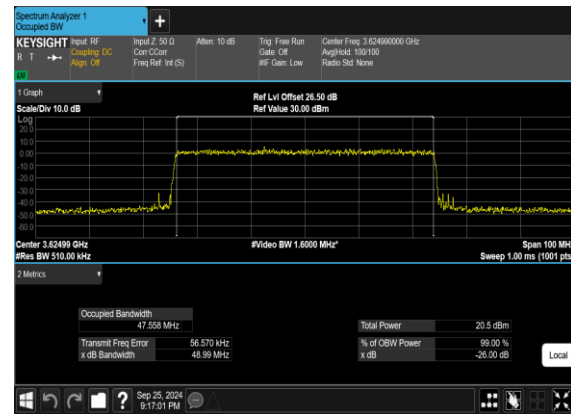



N48(50M)_CP-OFDM_QPSK_Outer_Full_High_CH

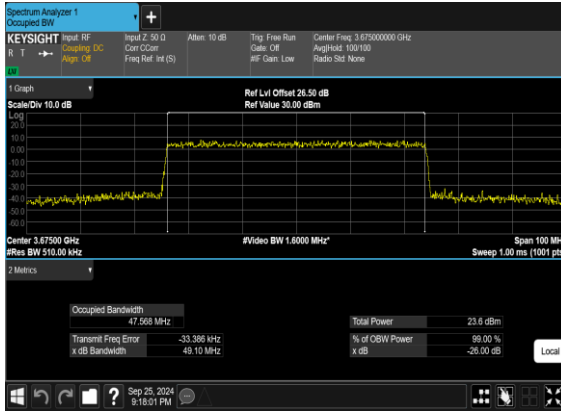

N48(50M)_CP-OFDM_16QAM_Outer_Full_High_CH

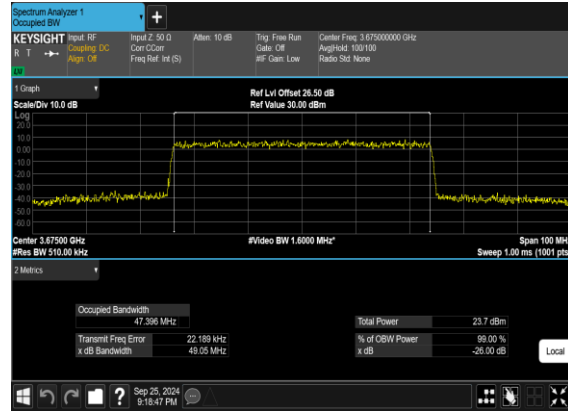

N48(50M)_CP-OFDM_64QAM_Outer_Full_High_CH

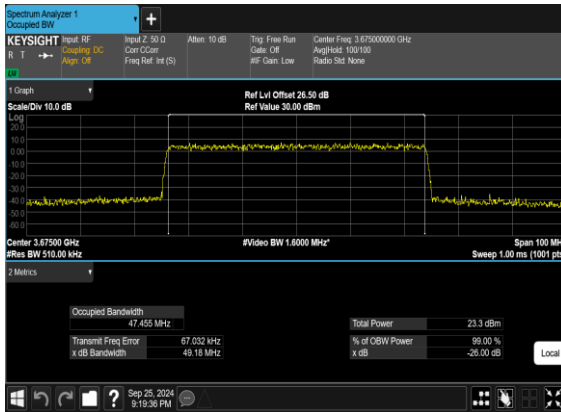

N48(50M)_CP-OFDM_256QAM_Outer_Full_High_CH

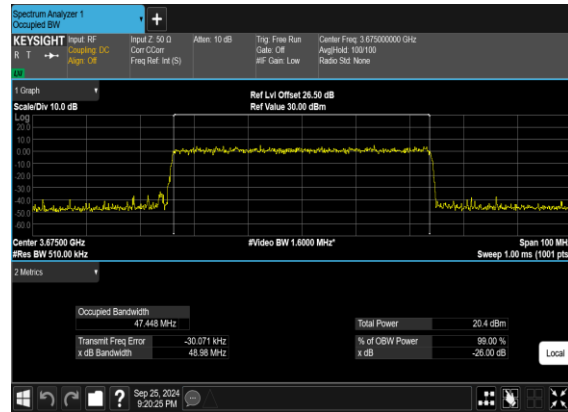



N48(60M)_CP-OFDM_QPSK_Outer_Full_Low_CH

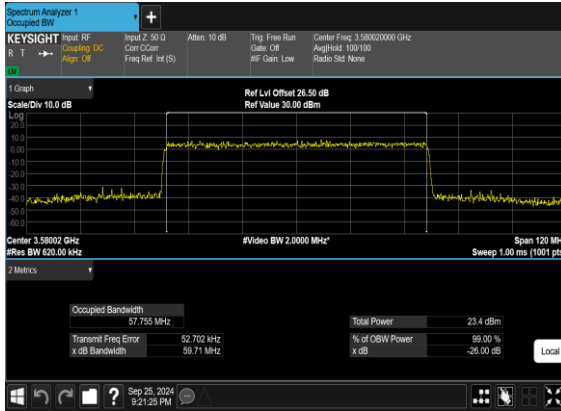

N48(60M)_CP-OFDM_16QAM_Outer_Full_Low_CH

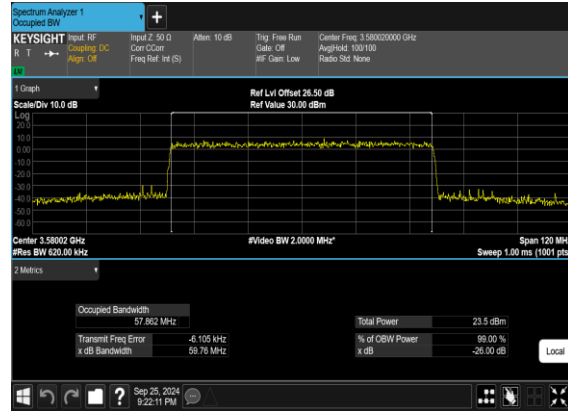

N48(60M)_CP-OFDM_64QAM_Outer_Full_Low_CH

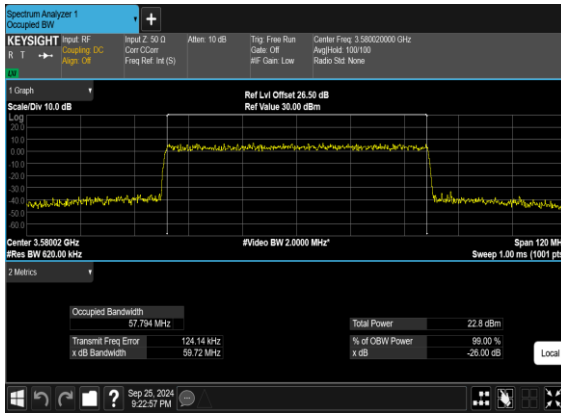

N48(60M)_CP-OFDM_256QAM_Outer_Full_Low_CH

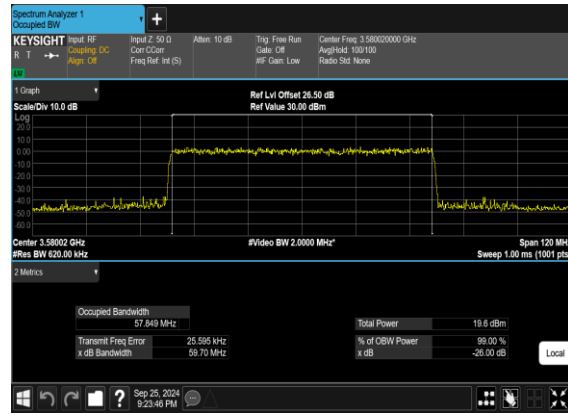



N48(60M)_CP-OFDM_QPSK_Outer_Full_Mid_CH

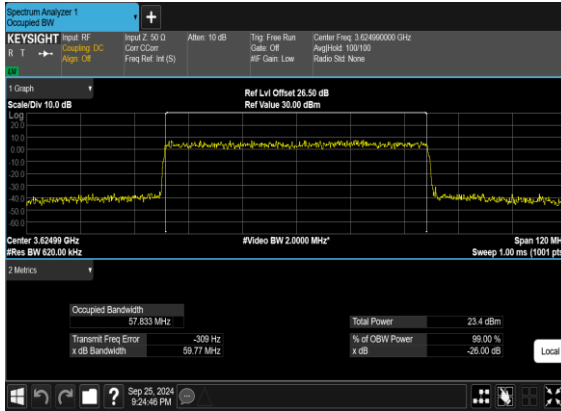

N48(60M)_CP-OFDM_16QAM_Outer_Full_Mid_CH

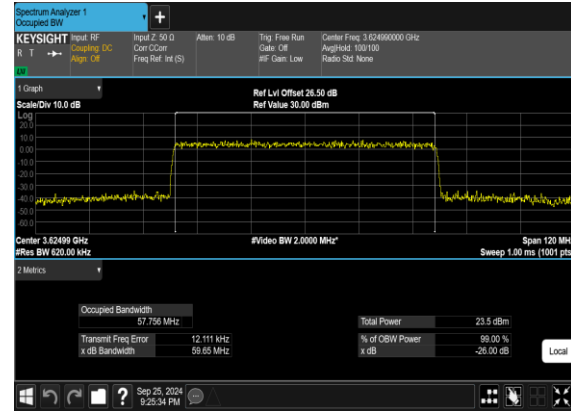

N48(60M)_CP-OFDM_64QAM_Outer_Full_Mid_CH

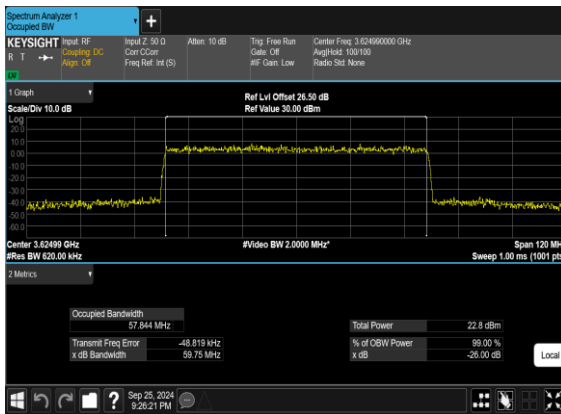

N48(60M)_CP-OFDM_256QAM_Outer_Full_Mid_CH

