



FCC RF Test Report

APPLICANT : Motorola Mobility LLC
EQUIPMENT : Mobile Cellular Phone
BRAND NAME : Motorola
MODEL NAME : XT2551-1, XT2551-2, XT2551-6
FCC ID : IHDT56AU1
STANDARD : 47 CFR Part 24, 27
CLASSIFICATION : PCS Licensed Transmitter Held to Ear (PCE)
TEST DATE(S) : Dec. 11, 2024 ~ Jan. 01, 2025

We, Sporton International Inc. (Kunshan), would like to declare that the tested sample has been evaluated in accordance with the procedures given in ANSI C63.26-2015 and shown compliance with the applicable technical standards.

The test results in this report apply exclusively to the tested model / sample. Without written approval of Sporton International Inc. (Kunshan), the test report shall not be reproduced except in full.

Jason Jia

Approved by: Jason Jia



Sporton International Inc. (Kunshan)

**No. 1098, Pengxi North Road, Kunshan Economic Development Zone Jiangsu Province 215300
People's Republic of China**



TABLE OF CONTENTS

REVISION HISTORY... 3
SUMMARY OF TEST RESULT ... 4
1 GENERAL DESCRIPTION ... 5
1.1 Applicant ... 5
1.2 Manufacturer ... 5
1.3 Product Feature of Equipment Under Test ... 5
1.4 Product Specification of Equipment Under Test ... 5
1.5 Modification of EUT ... 6
1.6 Maximum EIRP and Emission Designator ... 7
1.7 Testing Location ... 9
1.8 Test Software ... 9
1.9 Applicable Standards ... 10
1.10 Specification of Accessory ... 10
2 TEST CONFIGURATION OF EQUIPMENT UNDER TEST ... 11
2.1 Test Mode ... 11
2.2 Connection Diagram of Test System ... 13
2.3 Support Unit used in test configuration and system ... 13
2.4 Measurement Results Explanation Example ... 14
2.5 Frequency List of Low/Middle/High Channels ... 14
3 CONDUCTED TEST ITEMS ... 17
3.1 Measuring Instruments ... 17
3.2 Test Setup ... 17
3.3 Test Result of Conducted Test ... 17
3.4 Conducted Output Power and EIRP ... 18
3.5 Peak-to-Average Ratio ... 19
3.6 Occupied Bandwidth ... 20
3.7 Conducted Band Edge ... 21
3.8 Conducted Spurious Emission ... 22
3.9 Frequency Stability ... 23
4 RADIATED TEST ITEMS ... 24
4.1 Measuring Instruments ... 24
4.2 Test Setup ... 24
4.3 Test Result of Radiated Test ... 25
4.4 Radiated Spurious Emission ... 26
5 LIST OF MEASURING EQUIPMENT ... 27
6 MEASUREMENT UNCERTAINTY ... 28
APPENDIX A. TEST RESULTS OF CONDUCTED TEST
APPENDIX B. TEST RESULTS OF RADIATED TEST
APPENDIX C. TEST SETUP PHOTOGRAPHS



SUMMARY OF TEST RESULT

Report Section	FCC Rule	Description	Limit	Result	Remark
3.4	§2.1046	Conducted Output Power	Reporting Only	PASS	-
	§24.232(c)	Equivalent Isotropic Radiated Power (5G NR n2, n25)	EIRP < 2Watt		
	§27.50(d)(4)	Equivalent Isotropic Radiated Power (5G NR n66, n70)	EIRP < 1Watt		
3.5	§24.232(d)	Peak-to-Average Ratio	<13 dB	PASS	-
3.6	§2.1049	Occupied Bandwidth	Reporting Only	PASS	-
3.7	§2.1051 §24.238(a) §27.53(h)	Conducted Band Edge Measurement (5G NR n2, n25) (5G NR n66, n70)	< 43+10log10(P[Watts])	PASS	-
3.8	§2.1051 §24.238(a) §27.53(h)	Conducted Spurious Emission (5G NR n2, n25) (5G NR n66, n70)	< 43+10log10(P[Watts])	PASS	-
3.9	§2.1055 §24.235 §27.54	Frequency Stability Temperature & Voltage	Within Authorized Band	PASS	-
4.4	§2.1053 §24.238(a) §27.53(h)	Radiated Spurious Emission (5G NR n2, n25) (5G NR n66, n70)	< 43+10log10(P[Watts])	PASS	Under limit 26.63 dB at 5595.00 MHz

Conformity Assessment Condition:

- The test results (PASS/FAIL) with all measurement uncertainty excluded are presented against the regulation limits or in accordance with the requirements stipulated by the applicant/matrix manufacturer who shall bear all the risks of non-compliance that may potentially occur if measurement uncertainty is taken into account.
- The measurement uncertainty please refer to each test result in the section "Measurement Uncertainty"

Disclaimer:

The product specifications of the EUT presented in the test report that may affect the test assessments are declared by the manufacturer who shall take full responsibility for the authenticity.



1 General Description

1.1 Applicant

Motorola Mobility LLC
222 W,Merchandise Mart Plaza, Chicago IL 60654 USA

1.2 Manufacturer

Motorola Mobility LLC
222 W,Merchandise Mart Plaza, Chicago IL 60654 USA

1.3 Product Feature of Equipment Under Test

Product Feature	
Equipment	Mobile Cellular Phone
Brand Name	Motorola
Model Name	XT2551-1, XT2551-2, XT2551-6
FCC ID	IHDT56AU1
IMEI Code	Conducted : 350086570033998/350086570034004 Radiation : 350086570035852/350086570035860
HW Version	DVT2
SW Version	V2VL35.5
EUT Stage	Identical Prototype

Note : The three model name XT2551-1, XT2551-2, XT2551-6 are the same product except model name different for market segment.

1.4 Product Specification of Equipment Under Test

Standards-related Product Specification	
Tx Frequency	5G NR n2 : 1850 MHz ~ 1910 MHz 5G NR n25 : 1850 MHz ~ 1915 MHz 5G NR n66 : 1710 MHz ~ 1780 MHz 5G NR n70 : 1695 MHz ~ 1710 MHz
Rx Frequency	5G NR n2 : 1930 MHz ~ 1990 MHz 5G NR n25 : 1930 MHz ~ 1995 MHz 5G NR n66 : 2110 MHz~ 2200 MHz 5G NR n70 : 1995 MHz ~ 2020 MHz
Bandwidth	n2: 5MHz / 10MHz / 15MHz / 20MHz / 25MHz / 30MHz / 35MHz / 40MHz n25 : 5MHz / 10MHz / 15MHz / 20MHz / 25MHz / 30MHz / 35MHz / 40MHz / 45MHz(Downlink only) n66: 5MHz / 10MHz / 15MHz / 20MHz / 25MHz / 30MHz / 35MHz / 40MHz/ 45MHz n70: 5MHz / 10MHz / 15MHz / 20MHz(Downlink only) / 25MHz (Downlink only)



SCS	15kHz
Antenna Gain	<p><Ant. 0>: n2: -2.8 dBi n25: -2.8 dBi n66: -5.1 dBi n70: -8.1 dBi</p> <p><Ant. 1>: n2: -3.6 dBi n25: -3.6 dBi n66: -2.7 dBi n70: -3.0 dBi</p> <p><Ant. 2>: n2: -2.0 dBi n25: -2.0 dBi n66: -1.4 dBi n70: -1.4 dBi</p> <p><Ant. 3>: n2: -2.4 dBi n25: -2.3 dBi n66: -2.1 dBi n70: -1.8 dBi</p>
Type of Modulation	CP-OFDM: QPSK / 16QAM / 64QAM / 256QAM DFT-s-OFDM: PI/2 BPSK / QPSK / 16QAM / 64QAM / 256QAM

Remark:

1. The maximum EIRP is calculated from max output power and max antenna gain, only the maximum EIRP are shown in the report, 5G NR n66 for Ant. 2 and n2/n25/n70 for Ant. 3 and n2_UL MIMO/n25_UL MIMO/n66_UL MIMO for Ant.(2+3).
2. All the supported ENDC combinations are verified conducted power, only the ENDC combination with highest power are shown in the report.
3. 5G NR support SA (n2/n25/n66/n70) mode and NSA(n2/n25/n66) mode. According to the maximum power between SA and NSA mode, SA covers NSA mode for (n2/n25/n66) which support PC3.
4. For 5G NR n2/n25/n66 UL_MIMO mode support PC2.
5. 5G NR n2/n25/n66 supports UL MIMO mode (the two antennas are completely uncorrelated).
6. For n2/n25/n66MIMO mode, the conducted BE/Spurious are tested at single antenna port and add $10 \cdot \log(N_{ANT})$ according to KDB 662911 D01.
7. The device supports two PAs(Main PA and other PA) for 5G NR n2/n25/n66/n70, we chose higher power PA to calculate the EIRP and show in the report.
8. 5G NR n2/n66 also supports two paths, match to Main PA+1st Path/2nd Path or Other PA + 1st Path/2nd Path, we chose higher power of path with the same PA to test.
9. The EN-DC mode combination could be referred to the product spec.
10. 5G NR n25/n66 EN-DC mode supports maximum bandwidth is 40MHz.

1.5 Modification of EUT

No modifications are made to the EUT during all test items.



1.6 Maximum EIRP and Emission Designator

5G NR n2		PI/2 BPSK / QPSK		16QAM / 64QAM / 256QAM	
BW (MHz)	Frequency Range (MHz)	Maximum EIRP(W)	Emission Designator (99%OBW)	Maximum EIRP(W)	Emission Designator (99%OBW)
5	1852.5 ~ 1907.5	0.1239	4M47G7D	0.1047	4M48W7D
10	1855.0 ~ 1905.0	0.1271	9M28G7D	0.1030	9M29W7D
15	1857.5 ~ 1902.5	0.1271	14M1G7D	0.1059	14M1W7D
20	1860.0 ~ 1900.0	0.1265	18M9G7D	0.1042	18M9W7D
25	1862.5 ~ 1897.5	0.1315	23M7G7D	0.1064	23M8W7D
30	1865.0 ~ 1895.0	0.1282	28M6G7D	0.1033	28M6W7D
35	1867.5 ~ 1892.5	0.1285	33M5G7D	0.1052	33M6W7D
40	1870.0 ~ 1890.0	0.1303	38M6G7D	0.1074	38M6W7D

5G NR n2 UL MIMO		PI/2 BPSK / QPSK		16QAM / 64QAM / 256QAM	
BW (MHz)	Frequency Range (MHz)	Maximum EIRP(W)	Emission Designator (99%OBW)	Maximum EIRP(W)	Emission Designator (99%OBW)
5	1852.5 ~ 1907.5	0.2585	4M50G7D	0.2213	4M49W7D
10	1855.0 ~ 1905.0	0.2604	9M27G7D	0.2201	9M30W7D
15	1857.5 ~ 1902.5	0.2598	14M1G7D	0.2213	14M1W7D
20	1860.0 ~ 1900.0	0.2583	18M9G7D	0.2211	18M9W7D
25	1862.5 ~ 1897.5	0.2641	23M8G7D	0.2244	23M8W7D
30	1865.0 ~ 1895.0	0.2629	28M6G7D	0.2244	28M6W7D
35	1867.5 ~ 1892.5	0.2619	33M5G7D	0.2217	33M5W7D
40	1870.0 ~ 1890.0	0.2671	38M5G7D	0.2286	38M5W7D

5G NR n25		PI/2 BPSK / QPSK		16QAM / 64QAM / 256QAM	
BW (MHz)	Frequency Range (MHz)	Maximum EIRP(W)	Emission Designator (99%OBW)	Maximum EIRP(W)	Emission Designator (99%OBW)
5	1852.5 ~ 1912.5	0.1343	4M47G7D	0.1112	4M48W7D
10	1855.0 ~ 1910.0	0.1343	9M28G7D	0.1112	9M29W7D
15	1857.5 ~ 1907.5	0.1334	14M1G7D	0.1099	14M1W7D
20	1860.0 ~ 1905.0	0.1340	18M9G7D	0.1089	18M9W7D
25	1862.5 ~ 1902.5	0.1334	23M7G7D	0.1130	23M8W7D
30	1865.0 ~ 1900.0	0.1365	28M6G7D	0.1125	28M6W7D
35	1867.5 ~ 1897.5	0.1312	33M5G7D	0.1107	33M6W7D
40	1870.0 ~ 1895.0	0.1337	38M6G7D	0.1125	38M6W7D



5G NR n25 UL MIMO		PI/2 BPSK / QPSK		16QAM / 64QAM / 256QAM	
BW (MHz)	Frequency Range (MHz)	Maximum EIRP(W)	Emission Designator (99%OBW)	Maximum EIRP(W)	Emission Designator (99%OBW)
5	1852.5 ~ 1912.5	0.2661	4M50G7D	0.2242	4M49W7D
10	1855.0 ~ 1910.0	0.2681	9M27G7D	0.2273	9M30W7D
15	1857.5 ~ 1907.5	0.2683	14M1G7D	0.2286	14M1W7D
20	1860.0 ~ 1905.0	0.2678	18M9G7D	0.2281	18M9W7D
25	1862.5 ~ 1902.5	0.2728	23M8G7D	0.2247	23M8W7D
30	1865.0 ~ 1900.0	0.2674	28M6G7D	0.2226	28M6W7D
35	1867.5 ~ 1897.5	0.2759	33M5G7D	0.2321	33M5W7D
40	1870.0 ~ 1895.0	0.2660	38M5G7D	0.2257	38M5W7D
5G NR n66		PI/2 BPSK / QPSK		16QAM / 64QAM / 256QAM	
BW (MHz)	Frequency Range (MHz)	Maximum EIRP(W)	Emission Designator (99%OBW)	Maximum EIRP(W)	Emission Designator (99%OBW)
5	1712.5 ~ 1777.5	0.1524	4M48G7D	0.1274	4M49W7D
10	1715.0 ~ 1775.0	0.1552	9M29G7D	0.1288	9M31W7D
15	1717.5 ~ 1772.5	0.1570	14M1G7D	0.1294	14M1W7D
20	1720.0 ~ 1770.0	0.1524	18M9G7D	0.1282	19M0W7D
25	1722.5 ~ 1767.5	0.1528	23M8G7D	0.1274	23M8W7D
30	1725.0 ~ 1765.0	0.1552	28M5G7D	0.1276	28M6W7D
35	1727.5 ~ 1762.5	0.1510	33M6G7D	0.1294	33M6W7D
40	1730.0 ~ 1760.0	0.1521	38M5G7D	0.1279	38M6W7D
45	1732.5 ~ 1757.5	0.1614	43M3G7D	0.1374	43M3W7D
5G NR n66 UL MIMO		PI/2 BPSK / QPSK		16QAM / 64QAM / 256QAM	
BW (MHz)	Frequency Range (MHz)	Maximum EIRP(W)	Emission Designator (99%OBW)	Maximum EIRP(W)	Emission Designator (99%OBW)
5	1712.5 ~ 1777.5	0.2960	4M49G7D	0.2547	4M48W7D
10	1715.0 ~ 1775.0	0.3053	9M27G7D	0.2556	9M30W7D
15	1717.5 ~ 1772.5	0.3019	14M1G7D	0.2579	14M1W7D
20	1720.0 ~ 1770.0	0.2963	18M9G7D	0.2502	19M0W7D
25	1722.5 ~ 1767.5	0.3013	23M8G7D	0.2583	23M8W7D
30	1725.0 ~ 1765.0	0.3015	28M6G7D	0.2586	28M6W7D
35	1727.5 ~ 1762.5	0.2997	33M6G7D	0.2536	33M6W7D
40	1730.0 ~ 1760.0	0.3021	38M5G7D	0.2535	38M6W7D
45	1732.5 ~ 1757.5	0.3184	43M2G7D	0.2752	43M2W7D



5G NR n70		PI/2 BPSK / QPSK		16QAM / 64QAM / 256QAM	
BW (MHz)	Frequency Range (MHz)	Maximum EIRP(W)	Emission Designator (99%OBW)	Maximum EIRP(W)	Emission Designator (99%OBW)
5	1697.5 ~ 1707.5	0.1297	4M46G7D	0.1067	4M48W7D
10	1700.0 ~ 1705.0	0.1294	9M29G7D	0.1054	9M29W7D
15	1702.5	0.1297	14M1G7D	0.1059	14M1W7D

Note:

- 5G NR n25 overlaps the entire frequency range of 5G NR n2. Therefore, the test results provided in this report covers 5G NR n25 as well as 5G NR n2.
- All modulations have been tested, only the worst test results of PSK & QAM are shown in the report.

1.7 Testing Location

Sporton International Inc. (Kunshan) is accredited to ISO/IEC 17025:2017 by American Association for Laboratory Accreditation with Certificate Number 5145.02.

Test Firm	Sporton International Inc. (Kunshan)		
Test Site Location	No. 1098, Pengxi North Road, Kunshan Economic Development Zone Jiangsu Province 215300 People's Republic of China TEL : +86-512-57900158		
Test Site No.	Sporton Site No.	FCC Designation No.	FCC Test Firm Registration No.
	03CH03-KS TH01-KS	CN1257	314309

1.8 Test Software

Item	Site	Manufacture	Name	Version
1.	TH01-KS	Tonscend	JS1120-3 test system China_210602	3.3.10
2.	03CH03-KS	AUDIX	E3	210616



1.9 Applicable Standards

According to the specifications of the manufacturer, the EUT must comply with the requirements of the following standards:

- 47 CFR Part 24, 27
- ANSI C63.26-2015
- FCC KDB 971168 D01 Power Meas License Digital Systems v03r01
- FCC KDB 412172 D01 Determining ERP and EIRP v01r01

Remark:

All test items were verified and recorded according to the standards and without any deviation during the test.

1.10 Specification of Accessory

Accessories Information				
AC Adapter 1(US)	Brand Name	Motorola(Chenyang)	Model Name	MC-681N
AC Adapter 1(EU)	Brand Name	Motorola(Chenyang)	Model Name	MC-682N
AC Adapter 1(UK)	Brand Name	Motorola(Chenyang)	Model Name	MC-683N
AC Adapter 1(AU)	Brand Name	Motorola(Chenyang)	Model Name	MC-685N
AC Adapter 1(AR)	Brand Name	Motorola(Chenyang)	Model Name	MC-686N
AC Adapter 1(BR)	Brand Name	Motorola(Chenyang)	Model Name	MC-687N
AC Adapter 1(Chile)	Brand Name	Motorola(Chenyang)	Model Name	MC-689N
AC Adapter 2(US)	Brand Name	Motorola(Acbel)	Model Name	MC-681N
AC Adapter 2(EU)	Brand Name	Motorola(Acbel)	Model Name	MC-682N
AC Adapter 2(UK)	Brand Name	Motorola(Acbel)	Model Name	MC-683N
AC Adapter 2(AU)	Brand Name	Motorola(Acbel)	Model Name	MC-685N
AC Adapter 2(AR)	Brand Name	Motorola(Acbel)	Model Name	MC-686N
AC Adapter 2(BR)	Brand Name	Motorola(Acbel)	Model Name	MC-687N
Battery 1	Brand Name	Motorola(ATL)	Model Name	RS13
Battery 2	Brand Name	Motorola(ATL)	Model Name	RS35
USB Cable 1	Brand Name	Motorola(saibao)	Model Name	SC18D71644
USB Cable 2	Brand Name	Motorola(Luxshare)	Model Name	SC18E08104
USB Cable 3	Brand Name	Motorola(saibao)	Model Name	SC18D86731
USB Cable 4	Brand Name	Motorola(Luxshare)	Model Name	SC18E08103

2 Test Configuration of Equipment Under Test



2.1 Test Mode

Antenna port conducted and radiated test items are performed according to KDB 971168 D01 Power Meas License Digital Systems v03r01 with maximum output power.

For radiated measurement, pre-scanned in three orthogonal panels, X, Y, Z. The worst cases (Z plane) were recorded in this report.

The EUT is a folding phone, pretest the open status and closed status, only the worst status perform final test and record in the report. For the accessories, pretest standalone mode / Earphone mode / Adapter mode / Wireless charging mode, only the worst status perform final test and record in the report.

The device is investigated from 30MHz to 10 times of fundamental signal for radiated spurious emission test under different RB size/offset and modulations in exploratory test. Subsequently, only the worst case emissions are reported.

	X Plane	Y Plane	Z Plane
Orthogonal Planes of EUT			

Test Items	5G NR	Bandwidth (MHz)													Modulation					RB #		Test Channel		
		5	10	15	20	25	30	35	40	45	50~70	80	90	100	PI/2 BPSK	QPSK	16QAM	64QAM	256QAM	1	Full	L	M	H
Max. Output Power	n2	v	v	v	v	v	v	v	v	-	-	-	-	-	v	v	v	v	v	v	v	v	v	v
	n25	v	v	v	v	v	v	v	v	-	-	-	-	-	v	v	v	v	v	v	v	v	v	v
	n66	v	v	v	v	v	v	v	v	v	-	-	-	-	v	v	v	v	v	v	v	v	v	v
	n70	v	v	v	-	-	-	-	-	-	-	-	-	-	v	v	v	v	v	v	v	v	v	v
Peak-to-Average Ratio	n25				v					-	-	-	-	-	v	v				v	v			v
	n66				v					-	-	-	-	-	v	v				v	v			v
	n70			v	-	-	-	-	-	-	-	-	-	-	v	v				v	v			v
26dB and 99% Bandwidth	n25	v	v	v	v	v	v	v	v	-	-	-	-	-		v	v	v	v		v			v
	n66	v	v	v	v	v	v	v	v	v	-	-	-	-		v	v	v	v		v			v
	n70	v	v	v	-	-	-	-	-	-	-	-	-	-		v	v	v	v		v			v
Conducted Band Edge	n25	v			v				v	-	-	-	-	-	v	v				v	v	v		v
	n66	v			v				v	-	-	-	-	-	v	v				v	v	v		v
	n70	v	v	v	-	-	-	-	-	-	-	-	-	-	v	v				v	v	v		v



Test Items	5G NR	Bandwidth (MHz)												Modulation					RB #		Test Channel			
		5	10	15	20	25	30	35	40	45	50~70	80	90	100	PI/2 BPSK	QPSK	16QAM	64QAM	256QAM	1	Full	L	M	H
Conducted Spurious Emission	n25	v			v				v	-	-	-	-	-	v	v				v		v	v	v
	n66	v			v				v	-	-	-	-	-	v	v				v		v	v	v
	n70	v	v	v	-	-	-	-	-	-	-	-	-	-	v	v				v		v	v	v
Frequency Stability	n25				v					-	-	-	-	-		v					v		v	
	n66				v					-	-	-	-	-		v					v		v	
	n70			v	-	-	-	-	-	-	-	-	-	-		v					v		v	
E.I.R.P	n2	v	v	v	v	v	v	v	v	-	-	-	-	-	v	v	v	v	v	v	v	v	v	v
	n25	v	v	v	v	v	v	v	v	-	-	-	-	-	v	v	v	v	v	v	v	v	v	v
	n66	v	v	v	v	v	v	v	v	-	-	-	-	-	v	v	v	v	v	v	v	v	v	v
	n70	v	v	v	-	-	-	-	-	-	-	-	-	-	v	v	v	v	v	v	v	v	v	v
Radiated Spurious Emission	n25	Worst Case																				v		
	n66	Worst Case																				v		
	n70	Worst Case																				v		
Note	<ol style="list-style-type: none"> The mark "v" means that this configuration is chosen for testing The mark "-" means that this bandwidth is not supported. The device is investigated from 30MHz to 10 times of fundamental signal for radiated spurious emission test under different RB size/offset and modulations in exploratory test. Subsequently, only the worst case emissions are reported. Frequency Stability : Normal Voltage = 3.86V ; Low Voltage =3.50V. ; High Voltage =4.53V 																							

2.2 Connection Diagram of Test System

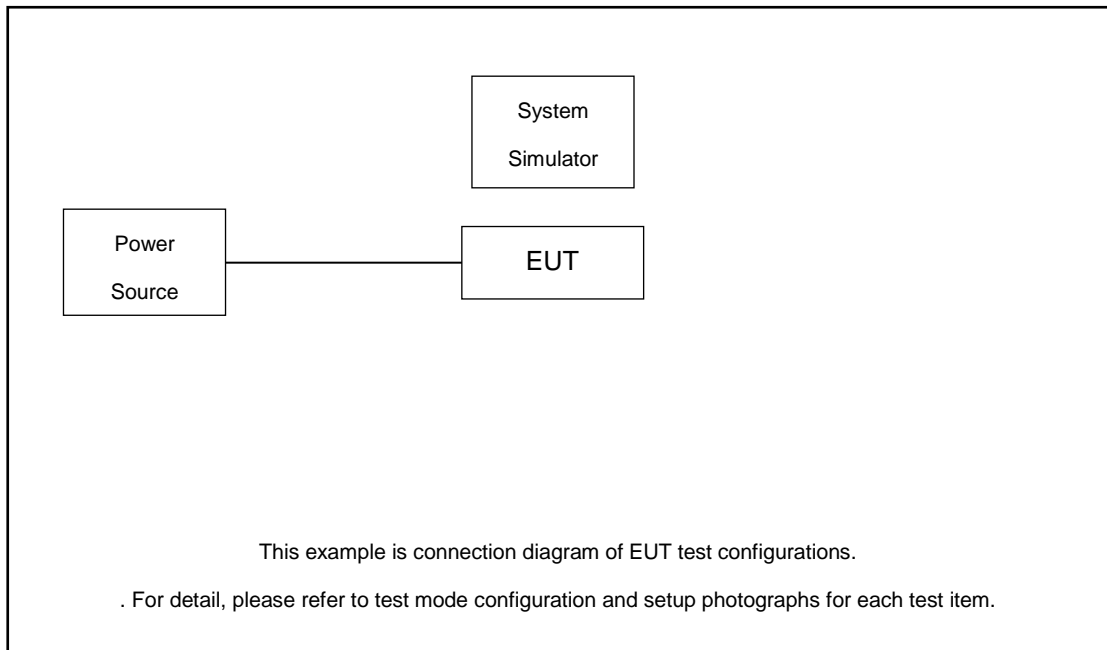

The EUT has been configuration operated in a manner tended to maximize its emission characteristics in a typical application.

2.3 Support Unit used in test configuration and system

Item	Equipment	Trade Name	Model No.	FCC ID	Data Cable	Power Cord
1.	DC Power Supply	GW	GPS-3030D	N/A	N/A	Unshielded, 1.8 m
2.	LTE Base Station	Anritsu	MT8821C	N/A	N/A	Unshielded, 1.8 m
3.	NR Base Station	Anritsu	MT8000A	N/A	N/A	Unshielded, 1.8 m



2.4 Measurement Results Explanation Example

For all conducted test items:

The offset level is set in the spectrum analyzer to compensate the RF cable loss and attenuator factor between EUT conducted output port and spectrum analyzer. With the offset compensation, the spectrum analyzer reading level is exactly the EUT RF output level.

The spectrum analyzer offset is derived from RF cable loss and attenuator factor.

$$\text{Offset} = \text{RF cable loss} + \text{attenuator factor}.$$

Following shows an offset computation example with cable loss 5.4 dB and 20dB attenuator.

Example :

$$\begin{aligned} \text{Offset(dB)} &= \text{RF cable loss(dB)} + \text{attenuator factor(dB)}. \\ &= 5.4 + 20 = 25.4 \text{ (dB)} \end{aligned}$$

2.5 Frequency List of Low/Middle/High Channels

5G NR n2 Channel and Frequency List				
BW [MHz]	Channel/Frequency(MHz)	Lowest	Middle	Highest
40	Channel	374000	376000	378000
	Frequency	1870	1880	1890
35	Channel	373500	376000	378500
	Frequency	1867.5	1880	1892.5
30	Channel	373000	376000	379000
	Frequency	1865	1880	1895
25	Channel	372500	376000	379500
	Frequency	1862.5	1880	1897.5
20	Channel	372000	376000	380000
	Frequency	1860	1880	1900
15	Channel	371500	376000	380500
	Frequency	1857.5	1880	1902.5
10	Channel	371000	376000	381000
	Frequency	1855	1880	1905
5	Channel	370500	376000	381500
	Frequency	1852.5	1880	1907.5



5G NR n25 Channel and Frequency List				
BW [MHz]	Channel/Frequency(MHz)	Lowest	Middle	Highest
40	Channel	390000	392500	395000
	Frequency	1870	1882.5	1895
35	Channel	373500	376500	379500
	Frequency	1867.5	1882.5	1897.5
30	Channel	389000	392500	396000
	Frequency	1865	1882.5	1900
25	Channel	388500	392500	396500
	Frequency	1862.5	1882.5	1902.5
20	Channel	372000	376500	381000
	Frequency	1860	1882.5	1905
15	Channel	371500	376500	381500
	Frequency	1857.5	1882.5	1907.5
10	Channel	371000	376500	382000
	Frequency	1855	1882.5	1910
5	Channel	370500	376500	382500
	Frequency	1852.5	1882.5	1912.5

5G NR n66 Channel and Frequency List				
BW [MHz]	Channel/Frequency(MHz)	Lowest	Middle	Highest
45	Channel	346500	349000	351500
	Frequency	1732.5	1745	1757.5
40	Channel	346000	349000	352000
	Frequency	1730	1745	1760
35	Channel	345500	349000	352500
	Frequency	1727.5	1745	1762.5
30	Channel	345000	349000	353000
	Frequency	1725	1745	1765
25	Channel	344500	349000	353500
	Frequency	1722.5	1745	1767.5
20	Channel	344000	349000	354000
	Frequency	1720	1745	1770
15	Channel	343500	349000	354500
	Frequency	1717.5	1745	1772.5
10	Channel	343000	349000	355000
	Frequency	1715	1745	1775



5	Channel	342500	349000	355500
	Frequency	1712.5	1745	1777.5

5G NR n70 Channel and Frequency List				
BW [MHz]	Channel/Frequency(MHz)	Lowest	Middle	Highest
15	Channel	340500		
	Frequency	1702.5		
10	Channel	340000	340500	341000
	Frequency	1700	1702.5	1705
5	Channel	399500	340500	341500
	Frequency	1697.5	1702.5	1707.5

3 Conducted Test Items

3.1 Measuring Instruments

See list of measuring instruments of this test report.

3.2 Test Setup

3.2.1 Conducted Output Power

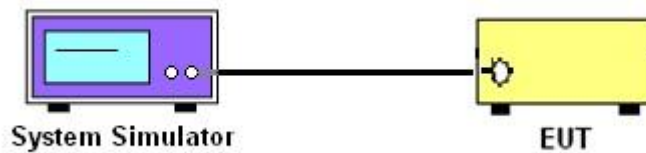

3.2.2 Peak-to-Average Ratio, Occupied Bandwidth ,Conducted Band-Edge and Conducted Spurious Emission

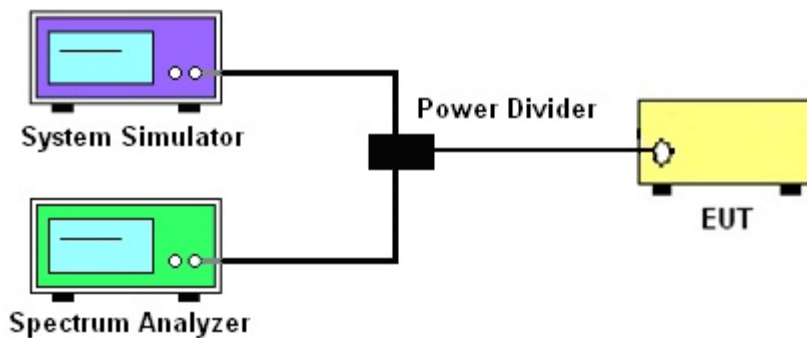

3.2.3 Frequency Stability

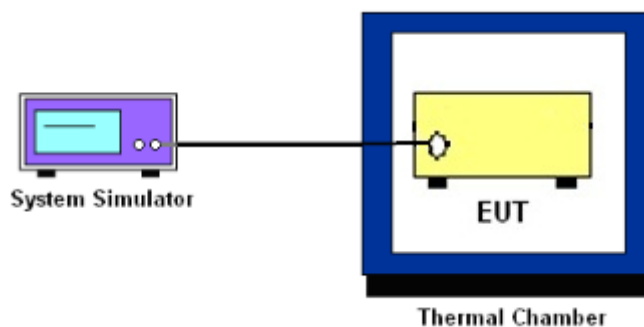

3.3 Test Result of Conducted Test

Please refer to Appendix A.



3.4 Conducted Output Power and EIRP

3.4.1 Description of the Conducted Output Power Measurement and EIRP Measurement

A system simulator was used to establish communication with the EUT. Its parameters were set to force the EUT transmitting at maximum output power. The measured power in the radio frequency on the transmitter output terminals shall be reported.

The EIRP of mobile transmitters must not exceed 2 Watts for 5G NR n2, n25.

The EIRP of mobile transmitters must not exceed 1 Watts for 5G NR n66, n70.

According to KDB 412172 D01 Power Approach,

$EIRP = P_T + G_T - L_C$, $ERP = EIRP - 2.15$, where

P_T = transmitter output power in dBm

G_T = gain of the transmitting antenna in dBi

L_C = signal attenuation in the connecting cable between the transmitter and antenna in dB

3.4.2 Test Procedures

1. The testing follows ANSI C63.26 Section 5.2
2. The transmitter output port was connected to the system simulator.
3. Set EUT at maximum power through the system simulator.
4. Select lowest, middle, and highest channels for each band and different modulation.
5. Measure and record the power level from the system simulator.



3.5 Peak-to-Average Ratio

3.5.1 Description of the PAR Measurement

Power Complementary Cumulative Distribution Function (CCDF) curves provide a means for characterizing the power peaks of a digitally modulated signal on a statistical basis. A CCDF curve depicts the probability of the peak signal amplitude exceeding the average power level. Most contemporary measurement instrumentation include the capability to produce CCDF curves for an input signal provided that the instrument's resolution bandwidth can be set wide enough to accommodate the entire input signal bandwidth. In measuring transmissions in this band using an average power technique, the peak-to-average ratio (PAR) of the transmission may not exceed 13 dB.

3.5.2 Test Procedures

1. The testing follows ANSI C63.26 Section 5.2.3.4 (CCDF).
2. The EUT was connected to spectrum and system simulator via a power divider.
3. Set the CCDF (Complementary Cumulative Distribution Function) option in spectrum analyzer.
4. The highest RF powers were measured and recorded the maximum PAPR level associated with a probability of 0.1 %.
5. Record the deviation as Peak to Average Ratio.



3.6 Occupied Bandwidth

3.6.1 Description of Occupied Bandwidth Measurement

The occupied bandwidth is the width of a frequency band such that, below the lower and above the upper frequency limits, the mean powers emitted are each equal to a specified percentage 0.5% of the total mean transmitted power.

The 26 dB emission bandwidth is defined as the frequency range between two points, one above and one below the carrier frequency, at which the spectral density of the emission is attenuated 26 dB below the maximum in-band spectral density of the modulated signal. Spectral density (power per unit bandwidth) is to be measured with a detector of resolution bandwidth equal to approximately 1.0% of the emission bandwidth.

3.6.2 Test Procedures

1. The testing follows ANSI C63.26 Section 5.4
2. The EUT was connected to spectrum analyzer and system simulator via a power divider.
3. The spectrum analyzer center frequency is set to the nominal EUT channel center frequency. The span range for the spectrum analyzer shall be between two and five times the anticipated OBW.
4. The nominal resolution bandwidth (RBW) shall be in the range of 1 to 5 % of the anticipated OBW, and the VBW shall be at least 3 times the RBW.
5. Set the detection mode to peak, and the trace mode to max hold.
6. Determine the reference value: Set the EUT to transmit a modulated signal. Allow the trace to stabilize. Set the spectrum analyzer marker to the highest level of the displayed trace.
(this is the reference value)
7. Determine the “-26 dB down amplitude” as equal to (Reference Value – X).
8. Place two markers, one at the lowest and the other at the highest frequency of the envelope of the spectral display such that each marker is at or slightly below the “-X dB down amplitude” determined in step 6. If a marker is below this “-X dB down amplitude” value it shall be placed as close as possible to this value. The OBW is the positive frequency difference between the two markers.
9. Use the 99 % power bandwidth function of the spectrum analyzer and report the measured bandwidth.



3.7 Conducted Band Edge

3.7.1 Description of Conducted Band Edge Measurement

24.238 (a)

For operations in the 1850-1910 and 1930-1990 MHz band, the FCC limit is $43 + 10\log_{10}(P[\text{Watts}])$ dB below the transmitter power $P(\text{Watts})$ in a 1MHz bandwidth. However, in the 1 MHz bands immediately outside and adjacent to the frequency block a resolution bandwidth of at least one percent of the emission bandwidth of the fundamental emission of the transmitter may be employed.

27.53 (h)

For operations in the 1710 – 1780 MHz band, the FCC limit is $43 + 10\log_{10}(P[\text{Watts}])$ dB below the transmitter power $P(\text{Watts})$ in a 1 MHz bandwidth. However, in the 1MHz bands immediately outside and adjacent to the licensee's frequency block, a resolution bandwidth of at least one percent of the emission bandwidth of the fundamental emission of the transmitter may be employed.

3.7.2 Test Procedures

1. The testing follows ANSI C63.26 section 5.7
2. The EUT was connected to spectrum analyzer and system simulator via a power divider.
3. The band edges of low and high channels for the highest RF powers were measured.
4. Set RBW \geq 1% EBW in the 1MHz band immediately outside and adjacent to the band edge.
5. Beyond the 1 MHz band from the band edge, RBW=1MHz was used or a narrower RBW was used (generally limited to no less than 1% of the OBW) and the measured power was integrated over the full required measurement bandwidth.
6. Set spectrum analyzer with RMS detector.
7. The RF fundamental frequency should be excluded against the limit line in the operating frequency band.
8. Checked that all the results comply with the emission limit line.

Example:

$$\begin{aligned} & \text{The limit line is derived from } 43 + 10\log(P)\text{dB below the transmitter power } P(\text{Watts}) \\ & = P(\text{W}) - [43 + 10\log(P)] \text{ (dB)} \\ & = [30 + 10\log(P)] \text{ (dBm)} - [43 + 10\log(P)] \text{ (dB)} = -13\text{dBm}. \end{aligned}$$

9. When using the integration method, the starting frequency of the integration shall be centered at one-half of the RBW away from the band edge.



3.8 Conducted Spurious Emission

3.8.1 Description of Conducted Spurious Emission Measurement

The power of any emission outside of the authorized operating frequency ranges must be lower than the transmitter power (P) by a factor of at least $43 + 10 \log (P)$ dB.

It is measured by means of a calibrated spectrum analyzer and scanned from 30 MHz up to a frequency including its 10th harmonic.

3.8.2 Test Procedures

1. The testing follows ANSI C63.26 section 5.7
2. The EUT was connected to spectrum analyzer and system simulator via a power divider.
3. The RF output of EUT was connected to the spectrum analyzer by RF cable and attenuator. The path loss was compensated to the results for each measurement.
4. The middle channel for the highest RF power within the transmitting frequency was measured.
5. The conducted spurious emission for the whole frequency range was taken.
6. Make the measurement with the spectrum analyzer's RBW = 1MHz, VBW = 3MHz.
7. Set spectrum analyzer with RMS detector.
8. Taking the record of maximum spurious emission.
9. The RF fundamental frequency should be excluded against the limit line in the operating frequency band.
10. The limit line is derived from $43 + 10\log(P)$ dB below the transmitter power P(Watts)
= P(W)- [43 + 10log(P)] (dB)
= [30 + 10log(P)] (dBm) - [43 + 10log(P)] (dB)
= -13dBm.



3.9 Frequency Stability

3.9.1 Description of Frequency Stability Measurement

The frequency stability shall be measured by variation of ambient temperature and variation of primary supply voltage to ensure that the fundamental emission stays within the authorized frequency block.

3.9.2 Test Procedures for Temperature Variation

1. The testing follows ANSI C63.26 section 5.6.4
2. The EUT was set up in the thermal chamber and connected with the system simulator.
3. With power OFF, the temperature was decreased to -30°C and the EUT was stabilized before testing. Power was applied and the maximum change in frequency was recorded within one minute.
4. With power OFF, the temperature was raised in 10°C step up to 50°C . The EUT was stabilized at each step for at least half an hour. Power was applied and the maximum frequency change was recorded within one minute.

3.9.3 Test Procedures for Voltage Variation

1. The testing follows ANSI C63.26 section 5.6.5
2. The EUT was placed in a temperature chamber at $20\pm 5^{\circ}\text{C}$ and connected with the system simulator.
3. The power supply voltage to the EUT was varied from 85% to 115% of the nominal value for other than hand carried battery equipment.
4. For hand carried, battery powered equipment, reduce the primary ac or dc supply voltage to the battery operating end point, which shall be specified by the manufacturer.
5. The variation in frequency was measured for the worst case.

4 Radiated Test Items

4.1 Measuring Instruments

See list of measuring instruments of this test report.

4.2 Test Setup

4.2.1 For radiated test below 30MHz

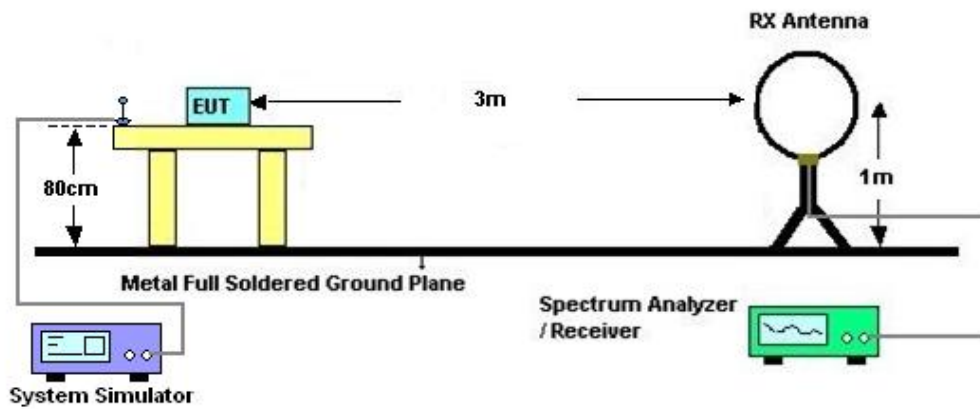

4.2.2 For radiated test from 30MHz to 1GHz

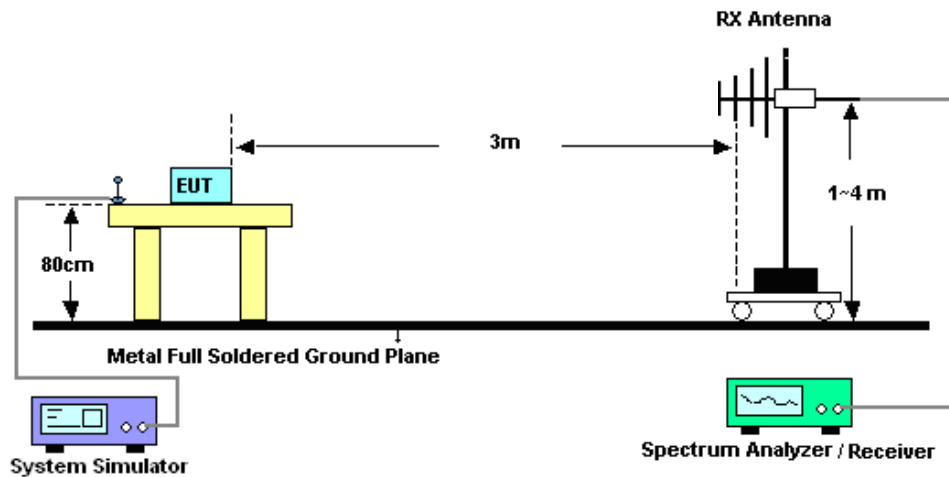

4.2.3 For radiated test above 1GHz

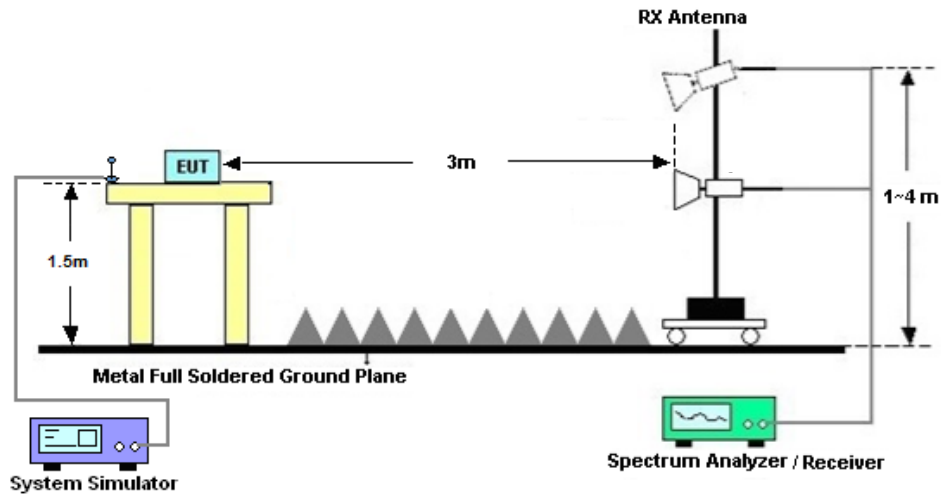

4.3 Test Result of Radiated Test

The low frequency, which started from 9 kHz to 30MHz, was pre-scanned and the result which was 20dB lower than the limit line was not reported.

Please refer to Appendix B.



4.4 Radiated Spurious Emission

4.4.1 Description of Radiated Spurious Emission

The radiated spurious emission was measured by substitution method according to ANSI C63.26. The power of any emission outside of the authorized operating frequency ranges must be attenuated below the transmitter power (P) by a factor of at least $43 + 10 \log (P)$ dB.

The spectrum is scanned from 30 MHz up to a frequency including its 10th harmonic.

4.4.2 Test Procedures

1. The testing follows ANSI C63.26 Section 5.5
2. The EUT was placed on a turntable with 0.8 meter height for frequency below 1GHz and 1.5 meter height for frequency above 1GHz respectively above ground.
3. The EUT was set 3 meters from the receiving antenna mounted on the antenna tower.
4. The table was rotated 360 degrees to determine the position of the highest spurious emission.
5. The height of the receiving antenna is varied between 1m to 4m to search the maximum spurious emission for both horizontal and vertical polarizations.
6. During the measurement, the system simulator parameters were set to force the EUT transmitting at maximum output power.
7. Make the measurement with the spectrum analyzer's RBW = 1MHz, VBW = 3MHz, taking the record of maximum spurious emission.
8. A horn antenna was substituted in place of the EUT and was driven by a signal generator.
9. Tune the output power of signal generator to the same emission level with EUT maximum spurious emission.
10. $EIRP (dBm) = S.G. Power - Tx Cable Loss + Tx Antenna Gain$
11. $ERP (dBm) = EIRP - 2.15$
12. The RF fundamental frequency should be excluded against the limit line in the operating frequency band.

The limit line is derived from $43 + 10\log(P)$ dB below the transmitter power P(Watts)
 $= P(W) - [43 + 10\log(P)] (dB)$
 $= [30 + 10\log(P)] (dBm) - [43 + 10\log(P)] (dB)$
 $= -13dBm.$



5 List of Measuring Equipment

Instrument	Manufacturer	Model No.	Serial No.	Characteristics	Calibration Date	Test Date	Due Date	Remark
Spectrum Analyzer	R&S	FSV40	101040	10Hz~40GHz	Oct. 10, 2024	Dec. 11, 2024~Jan. 01, 2025	Oct. 09, 2025	Conducted (TH01-KS)
Power divider	STI	STI08-0055	-	0.5~40GHz	NCR	Dec. 11, 2024~Jan. 01, 2025	NCR	Conducted (TH01-KS)
Temperature & humidity chamber	Hongzhan	LP-150U	H2014011440	-40~+150°C 20%~95%RH	Jul. 04, 2024	Dec. 11, 2024~Jan. 01, 2025	Jul. 03, 2025	Conducted (TH01-KS)
EMI Test Receiver	Keysight	N9038A	MY56400004	3Hz~8.5GHz;Max 30dBm	Oct. 11, 2024	Dec. 31, 2024	Oct. 10, 2025	Radiation (03CH03-KS)
EXA Spectrum Analyzer	Keysight	N9010A	MY55150244	10Hz-44GHz	Apr. 18, 2024	Dec. 31, 2024	Apr. 17, 2025	Radiation (03CH03-KS)
Loop Antenna	R&S	HFH2-Z2E	101125	9kHz~30MHz	Sep. 08, 2024	Dec. 31, 2024	Sep. 07, 2025	Radiation (03CH03-KS)
Bilog Antenna	TeseQ	CBL6112D	23182	30MHz-1GHz	Dec. 05, 2024	Dec. 31, 2024	Dec. 04, 2025	Radiation (03CH03-KS)
Double Ridge Horn Antenna	ETS-Lindgren	3117	00251982	1GHz~18GHz	Aug. 16, 2024	Dec. 31, 2024	Aug. 15, 2025	Radiation (03CH03-KS)
SHF-EHF Horn	com-power	AH-840	101093	18GHz~40GHz	Jan. 06, 2024	Dec. 31, 2024	Jan. 05, 2025	Radiation (03CH03-KS)
Amplifier	SONOMA	310N	413740	30MHz ~1000MHz	Jan. 03, 2024	Dec. 31, 2024	Jan. 02, 2025	Radiation (03CH03-KS)
Amplifier	EM	EM18G40G A	060851	18~40GHz	Jan. 03, 2024	Dec. 31, 2024	Jan. 02, 2025	Radiation (03CH03-KS)
high gain Amplifier	MITEQ	AMF-7D-00101800-30-10P	2082394	1Ghz-18Ghz	Jan. 03, 2024	Dec. 31, 2024	Jan. 02, 2025	Radiation (03CH03-KS)
Amplifier	Keysight	83017A	MY53270319	1GHz~26.5GHz	Oct. 09, 2024	Dec. 31, 2024	Oct. 08, 2025	Radiation (03CH03-KS)
AC Power Source	Chroma	61601	F104090004	N/A	NCR	Dec. 31, 2024	NCR	Radiation (03CH03-KS)
Turn Table	ChamPro	EM 1000-T	060762-T	0~360 degree	NCR	Dec. 31, 2024	NCR	Radiation (03CH03-KS)
Antenna Mast	ChamPro	EM 1000-A	060762-A	1 m~4 m	NCR	Dec. 31, 2024	NCR	Radiation (03CH03-KS)

NCR: No Calibration Required



6 Measurement Uncertainty

The measurement uncertainties shown below were calculated in accordance with the requirements of ANSI 63.26-2015. All the measurement uncertainty value were shown with a coverage K=2 to indicate 95% level of confidence. The measurement data show herein meets or exceeds the CISPR measurement uncertainty values specified in CISPR 16-4-2 and can be compared directly to specified limit to determine compliance.

Uncertainty of Conducted Measurement

Conducted Spurious Emission & Bandedge	±2.22 dB
Occupied Channel Bandwidth	±0.1%
Conducted Power	±0.50dB
Peak to Average Ratio	±0.46 dB
Frequency Stability	±0.04ppm

Uncertainty of Radiated Emission Measurement (30 MHz ~ 1000 MHz)

Measuring Uncertainty for a Level of Confidence of 95% (U = 2Uc(y))	2.84 dB
---	---------

Uncertainty of Radiated Emission Measurement (1 GHz ~ 18 GHz)

Measuring Uncertainty for a Level of Confidence of 95% (U = 2Uc(y))	2.84 dB
---	---------

Uncertainty of Radiated Emission Measurement (18 GHz ~ 40 GHz)

Measuring Uncertainty for a Level of Confidence of 95% (U = 2Uc(y))	2.83 dB
---	---------

----- THE END -----



Appendix A. Test Results of Conducted Test

Test Engineer :	Smile Wang	Temperature :	22~23°C
		Relative Humidity :	40~42%



FR1 N2 ANT3

Transmitter Conducted Output Power And EIRP, (G_T - L_C)=-2.4dB

NR Band	SCS	Bandwidth	Arfcn	Freq(MHz)	Modulation	RB	Conducted Power(dBm)	EIRP(dBm)	EIRP(W)
2	15	5	370500	1852.5	DFT-s-OFDM PI/2 BPSK	1@1	23.27	20.87	0.1222
2	15	5	370500	1852.5	DFT-s-OFDM QPSK	1@1	23.29	20.89	0.1227
2	15	5	370500	1852.5	DFT-s-OFDM 16 QAM	1@1	22.6	20.2	0.1047
2	15	5	376000	1880	DFT-s-OFDM PI/2 BPSK	1@1	23	20.6	0.1148
2	15	5	376000	1880	DFT-s-OFDM QPSK	1@1	23.12	20.72	0.1180
2	15	5	376000	1880	DFT-s-OFDM 16 QAM	1@1	22.3	19.9	0.0977
2	15	5	381500	1907.5	DFT-s-OFDM PI/2 BPSK	1@1	23.31	20.91	0.1233
2	15	5	381500	1907.5	DFT-s-OFDM QPSK	1@1	23.33	20.93	0.1239
2	15	5	381500	1907.5	DFT-s-OFDM 16 QAM	1@1	22.45	20.05	0.1012
2	15	10	371000	1855	DFT-s-OFDM PI/2 BPSK	1@1	23.44	21.04	0.1271
2	15	10	371000	1855	DFT-s-OFDM QPSK	1@1	23.26	20.86	0.1219
2	15	10	371000	1855	DFT-s-OFDM 16 QAM	1@1	22.53	20.13	0.1030
2	15	10	376000	1880	DFT-s-OFDM PI/2 BPSK	1@1	23.1	20.7	0.1175
2	15	10	376000	1880	DFT-s-OFDM QPSK	1@1	23.09	20.69	0.1172
2	15	10	376000	1880	DFT-s-OFDM 16 QAM	1@1	22.33	19.93	0.0984
2	15	10	381000	1905	DFT-s-OFDM PI/2 BPSK	1@1	23.35	20.95	0.1245
2	15	10	381000	1905	DFT-s-OFDM QPSK	1@1	23.17	20.77	0.1194
2	15	10	381000	1905	DFT-s-OFDM 16 QAM	1@1	22.45	20.05	0.1012
2	15	15	371500	1857.5	DFT-s-OFDM PI/2 BPSK	1@1	23.37	20.97	0.1250
2	15	15	371500	1857.5	DFT-s-OFDM QPSK	1@1	23.44	21.04	0.1271
2	15	15	371500	1857.5	DFT-s-OFDM 16 QAM	1@1	22.65	20.25	0.1059
2	15	15	376000	1880	DFT-s-OFDM PI/2 BPSK	1@1	23.25	20.85	0.1216
2	15	15	376000	1880	DFT-s-OFDM QPSK	1@1	23.23	20.83	0.1211
2	15	15	376000	1880	DFT-s-OFDM 16 QAM	1@1	22.43	20.03	0.1007
2	15	15	380500	1902.5	DFT-s-OFDM PI/2 BPSK	1@1	23.33	20.93	0.1239
2	15	15	380500	1902.5	DFT-s-OFDM QPSK	1@1	23.29	20.89	0.1227
2	15	15	380500	1902.5	DFT-s-OFDM 16 QAM	1@1	22.37	19.97	0.0993
2	15	20	372000	1860	DFT-s-OFDM PI/2 BPSK	1@1	23.42	21.02	0.1265
2	15	20	372000	1860	DFT-s-OFDM QPSK	1@1	23.34	20.94	0.1242
2	15	20	372000	1860	DFT-s-OFDM 16 QAM	1@1	22.58	20.18	0.1042
2	15	20	376000	1880	DFT-s-OFDM PI/2 BPSK	1@1	23.26	20.86	0.1219



2	15	20	376000	1880	DFT-s-OFDM QPSK	1@1	23.18	20.78	0.1197
2	15	20	376000	1880	DFT-s-OFDM 16 QAM	1@1	22.42	20.02	0.1005
2	15	20	380000	1900	DFT-s-OFDM PI/2 BPSK	1@1	23.24	20.84	0.1213
2	15	20	380000	1900	DFT-s-OFDM QPSK	1@1	23.1	20.7	0.1175
2	15	20	380000	1900	DFT-s-OFDM 16 QAM	1@1	22.39	19.99	0.0998
2	15	25	372500	1862.5	DFT-s-OFDM PI/2 BPSK	1@1	23.35	20.95	0.1245
2	15	25	372500	1862.5	DFT-s-OFDM QPSK	1@1	23.59	21.19	0.1315
2	15	25	372500	1862.5	DFT-s-OFDM 16 QAM	1@1	22.67	20.27	0.1064
2	15	25	376000	1880	DFT-s-OFDM PI/2 BPSK	1@1	23.43	21.03	0.1268
2	15	25	376000	1880	DFT-s-OFDM QPSK	1@1	23.36	20.96	0.1247
2	15	25	376000	1880	DFT-s-OFDM 16 QAM	1@1	22.5	20.1	0.1023
2	15	25	379500	1897.5	DFT-s-OFDM PI/2 BPSK	1@1	23.33	20.93	0.1239
2	15	25	379500	1897.5	DFT-s-OFDM QPSK	1@1	23.45	21.05	0.1274
2	15	25	379500	1897.5	DFT-s-OFDM 16 QAM	1@1	22.57	20.17	0.1040
2	15	30	373000	1865	DFT-s-OFDM PI/2 BPSK	1@1	23.35	20.95	0.1245
2	15	30	373000	1865	DFT-s-OFDM QPSK	1@1	23.48	21.08	0.1282
2	15	30	373000	1865	DFT-s-OFDM 16 QAM	1@1	22.54	20.14	0.1033
2	15	30	376000	1880	DFT-s-OFDM PI/2 BPSK	1@1	23.27	20.87	0.1222
2	15	30	376000	1880	DFT-s-OFDM QPSK	1@1	23.35	20.95	0.1245
2	15	30	376000	1880	DFT-s-OFDM 16 QAM	1@1	22.48	20.08	0.1019
2	15	30	379000	1895	DFT-s-OFDM PI/2 BPSK	1@1	23.25	20.85	0.1216
2	15	30	379000	1895	DFT-s-OFDM QPSK	1@1	23.13	20.73	0.1183
2	15	30	379000	1895	DFT-s-OFDM 16 QAM	1@1	22.46	20.06	0.1014
2	15	35	373500	1867.5	DFT-s-OFDM PI/2 BPSK	1@1	23.49	21.09	0.1285
2	15	35	373500	1867.5	DFT-s-OFDM QPSK	1@1	23.42	21.02	0.1265
2	15	35	373500	1867.5	DFT-s-OFDM 16 QAM	1@1	22.62	20.22	0.1052
2	15	35	376000	1880	DFT-s-OFDM PI/2 BPSK	1@1	23.22	20.82	0.1208
2	15	35	376000	1880	DFT-s-OFDM QPSK	1@1	23.36	20.96	0.1247
2	15	35	376000	1880	DFT-s-OFDM 16 QAM	1@1	22.42	20.02	0.1005
2	15	35	378500	1892.5	DFT-s-OFDM PI/2 BPSK	1@1	23.25	20.85	0.1216
2	15	35	378500	1892.5	DFT-s-OFDM QPSK	1@1	23.17	20.77	0.1194
2	15	35	378500	1892.5	DFT-s-OFDM 16 QAM	1@1	22.39	19.99	0.0998
2	15	40	374000	1870	DFT-s-OFDM PI/2 BPSK	108@54	23.19	20.79	0.1199
2	15	40	374000	1870	DFT-s-OFDM PI/2 BPSK	1@1	23.14	20.74	0.1186
2	15	40	374000	1870	DFT-s-OFDM PI/2 BPSK	1@214	23.04	20.64	0.1159
2	15	40	374000	1870	DFT-s-OFDM QPSK	108@54	23.13	20.73	0.1183
2	15	40	374000	1870	DFT-s-OFDM QPSK	1@1	23.13	20.73	0.1183



2	15	40	374000	1870	DFT-s-OFDM QPSK	1@214	23.04	20.64	0.1159
2	15	40	374000	1870	DFT-s-OFDM 16 QAM	108@54	22.3	19.9	0.0977
2	15	40	374000	1870	DFT-s-OFDM 16 QAM	1@1	22.26	19.86	0.0968
2	15	40	374000	1870	DFT-s-OFDM 16 QAM	1@214	22.26	19.86	0.0968
2	15	40	374000	1870	DFT-s-OFDM 64 QAM	108@54	20.35	17.95	0.0624
2	15	40	374000	1870	DFT-s-OFDM 64 QAM	1@1	20.65	18.25	0.0668
2	15	40	374000	1870	DFT-s-OFDM 64 QAM	1@214	20.6	18.2	0.0661
2	15	40	374000	1870	DFT-s-OFDM 256 QAM	108@54	17.89	15.49	0.0354
2	15	40	374000	1870	DFT-s-OFDM 256 QAM	1@1	17.35	14.95	0.0313
2	15	40	374000	1870	DFT-s-OFDM 256 QAM	1@214	17.38	14.98	0.0315
2	15	40	374000	1870	CP-OFDM QPSK	108@54	21.81	19.41	0.0873
2	15	40	374000	1870	CP-OFDM QPSK	1@1	22.02	19.62	0.0916
2	15	40	374000	1870	CP-OFDM QPSK	1@214	21.94	19.54	0.0899
2	15	40	376000	1880	DFT-s-OFDM PI/2 BPSK	108@54	23.21	20.81	0.1205
2	15	40	376000	1880	DFT-s-OFDM PI/2 BPSK	1@1	23.37	20.97	0.1250
2	15	40	376000	1880	DFT-s-OFDM PI/2 BPSK	1@214	23.4	21	0.1259
2	15	40	376000	1880	DFT-s-OFDM QPSK	108@54	23.11	20.71	0.1178
2	15	40	376000	1880	DFT-s-OFDM QPSK	1@1	23.35	20.95	0.1245
2	15	40	376000	1880	DFT-s-OFDM QPSK	1@214	23.53	21.13	0.1297
2	15	40	376000	1880	DFT-s-OFDM 16 QAM	108@54	22.43	20.03	0.1007
2	15	40	376000	1880	DFT-s-OFDM 16 QAM	1@1	22.4	20	0.1000
2	15	40	376000	1880	DFT-s-OFDM 16 QAM	1@214	22.59	20.19	0.1045
2	15	40	376000	1880	DFT-s-OFDM 64 QAM	108@54	20.42	18.02	0.0634
2	15	40	376000	1880	DFT-s-OFDM 64 QAM	1@1	20.55	18.15	0.0653
2	15	40	376000	1880	DFT-s-OFDM 64 QAM	1@214	20.78	18.38	0.0689
2	15	40	376000	1880	DFT-s-OFDM 256 QAM	108@54	17.83	15.43	0.0349
2	15	40	376000	1880	DFT-s-OFDM 256 QAM	1@1	17.37	14.97	0.0314
2	15	40	376000	1880	DFT-s-OFDM 256 QAM	1@214	17.63	15.23	0.0333
2	15	40	376000	1880	CP-OFDM QPSK	108@54	21.9	19.5	0.0891
2	15	40	376000	1880	CP-OFDM QPSK	1@1	22.12	19.72	0.0938
2	15	40	376000	1880	CP-OFDM QPSK	1@214	22.35	19.95	0.0989
2	15	40	378000	1890	DFT-s-OFDM PI/2 BPSK	108@54	23.21	20.81	0.1205
2	15	40	378000	1890	DFT-s-OFDM PI/2 BPSK	1@1	23.31	20.91	0.1233
2	15	40	378000	1890	DFT-s-OFDM PI/2 BPSK	1@214	23.55	21.15	0.1303
2	15	40	378000	1890	DFT-s-OFDM QPSK	108@54	23.28	20.88	0.1225
2	15	40	378000	1890	DFT-s-OFDM QPSK	1@1	23.19	20.79	0.1199
2	15	40	378000	1890	DFT-s-OFDM QPSK	1@214	23.52	21.12	0.1294



2	15	40	378000	1890	DFT-s-OFDM 16 QAM	108@54	22.46	20.06	0.1014
2	15	40	378000	1890	DFT-s-OFDM 16 QAM	1@1	22.42	20.02	0.1005
2	15	40	378000	1890	DFT-s-OFDM 16 QAM	1@214	22.71	20.31	0.1074
2	15	40	378000	1890	DFT-s-OFDM 64 QAM	108@54	20.45	18.05	0.0638
2	15	40	378000	1890	DFT-s-OFDM 64 QAM	1@1	20.63	18.23	0.0665
2	15	40	378000	1890	DFT-s-OFDM 64 QAM	1@214	20.91	18.51	0.0710
2	15	40	378000	1890	DFT-s-OFDM 256 QAM	108@54	17.96	15.56	0.0360
2	15	40	378000	1890	DFT-s-OFDM 256 QAM	1@1	17.34	14.94	0.0312
2	15	40	378000	1890	DFT-s-OFDM 256 QAM	1@214	17.7	15.3	0.0339
2	15	40	378000	1890	CP-OFDM QPSK	108@54	21.99	19.59	0.0910
2	15	40	378000	1890	CP-OFDM QPSK	1@1	22.01	19.61	0.0914
2	15	40	378000	1890	CP-OFDM QPSK	1@214	22.57	20.17	0.1040



FR1 N2 MIMO Ant2+Ant3

Transmitter Conducted Output Power And EIRP, (G_T - L_C)=-2dB

NR Band	SCS	BandWidth	Arfcn	Freq (MHz)	Modulation	RB	ANT2 Power (dBm)	ANT3 Power (dBm)	Conducted Power (dBm)	EIRP (dBm)	EIRP (W)
2	15	40	374000	1870	DFT-s-OFDM PI/2 BPSK	108@54	23.29	23.15	26.23	24.23	0.2649
2	15	40	374000	1870	DFT-s-OFDM PI/2 BPSK	1@1	23.13	23.17	26.16	24.16	0.2606
2	15	40	374000	1870	DFT-s-OFDM PI/2 BPSK	1@214	23.02	22.83	25.94	23.94	0.2475
2	15	40	374000	1870	DFT-s-OFDM QPSK	108@54	23.14	23.12	26.14	24.14	0.2594
2	15	40	374000	1870	DFT-s-OFDM QPSK	1@1	23.18	23.33	26.27	24.27	0.2671
2	15	40	374000	1870	DFT-s-OFDM QPSK	1@214	23.07	22.78	25.94	23.94	0.2476
2	15	40	374000	1870	DFT-s-OFDM 16 QAM	108@54	22.34	22.38	25.37	23.37	0.2173
2	15	40	374000	1870	DFT-s-OFDM 16 QAM	1@1	22.51	22.65	25.59	23.59	0.2286
2	15	40	374000	1870	DFT-s-OFDM 16 QAM	1@214	22.42	22.05	25.25	23.25	0.2113
2	15	40	374000	1870	DFT-s-OFDM 64 QAM	108@54	20.34	20.37	23.37	21.37	0.1369
2	15	40	374000	1870	DFT-s-OFDM 64 QAM	1@1	20.48	20.58	23.54	21.54	0.1426
2	15	40	374000	1870	DFT-s-OFDM 64 QAM	1@214	20.37	20	23.20	21.20	0.1318
2	15	40	374000	1870	DFT-s-OFDM 256 QAM	108@54	17.8	17.74	20.78	18.78	0.0755
2	15	40	374000	1870	DFT-s-OFDM 256 QAM	1@1	17.62	17.73	20.69	18.69	0.0739
2	15	40	374000	1870	DFT-s-OFDM 256 QAM	1@214	17.57	17.31	20.45	18.45	0.0700
2	15	40	374000	1870	CP-OFDM QPSK	108@54	21.84	21.93	24.90	22.90	0.1948
2	15	40	374000	1870	CP-OFDM QPSK	1@1	21.84	22	24.93	22.93	0.1964
2	15	40	374000	1870	CP-OFDM QPSK	1@214	21.73	21.47	24.61	22.61	0.1825
2	15	40	376000	1880	DFT-s-OFDM PI/2 BPSK	108@54	23.08	22.93	26.02	24.02	0.2521
2	15	40	376000	1880	DFT-s-OFDM PI/2 BPSK	1@1	23.12	23.22	26.18	24.18	0.2619
2	15	40	376000	1880	DFT-s-OFDM PI/2 BPSK	1@214	22.94	22.74	25.85	23.85	0.2427
2	15	40	376000	1880	DFT-s-OFDM QPSK	108@54	23.17	22.94	26.07	24.07	0.2551
2	15	40	376000	1880	DFT-s-OFDM QPSK	1@1	23.08	23.23	26.17	24.17	0.2610
2	15	40	376000	1880	DFT-s-OFDM QPSK	1@214	22.8	22.8	25.81	23.81	0.2405
2	15	40	376000	1880	DFT-s-OFDM 16 QAM	108@54	22.31	22.25	25.29	23.29	0.2133
2	15	40	376000	1880	DFT-s-OFDM 16 QAM	1@1	22.37	22.66	25.53	23.53	0.2253
2	15	40	376000	1880	DFT-s-OFDM 16 QAM	1@214	22.28	22.24	25.27	23.27	0.2123
2	15	40	376000	1880	DFT-s-OFDM 64 QAM	108@54	20.36	20.21	23.30	21.30	0.1348
2	15	40	376000	1880	DFT-s-OFDM 64 QAM	1@1	20.29	20.54	23.43	21.43	0.1389
2	15	40	376000	1880	DFT-s-OFDM 64 QAM	1@214	20.13	20.15	23.15	21.15	0.1303
2	15	40	376000	1880	DFT-s-OFDM 256 QAM	108@54	17.77	17.65	20.72	18.72	0.0745
2	15	40	376000	1880	DFT-s-OFDM 256 QAM	1@1	17.6	17.74	20.68	18.68	0.0738
2	15	40	376000	1880	DFT-s-OFDM 256 QAM	1@214	17.48	17.33	20.42	18.42	0.0694
2	15	40	376000	1880	CP-OFDM QPSK	108@54	21.77	21.71	24.75	22.75	0.1884
2	15	40	376000	1880	CP-OFDM QPSK	1@1	21.79	21.99	24.90	22.90	0.1950



2	15	40	376000	1880	CP-OFDM QPSK	1@214	21.66	21.74	24.71	22.71	0.1867
2	15	40	378000	1890	DFT-s-OFDM PI/2 BPSK	108@54	23.13	22.98	26.07	24.07	0.2550
2	15	40	378000	1890	DFT-s-OFDM PI/2 BPSK	1@1	23.13	23.34	26.25	24.25	0.2659
2	15	40	378000	1890	DFT-s-OFDM PI/2 BPSK	1@214	22.85	23.14	26.01	24.01	0.2516
2	15	40	378000	1890	DFT-s-OFDM QPSK	108@54	23.14	22.93	26.05	24.05	0.2539
2	15	40	378000	1890	DFT-s-OFDM QPSK	1@1	23.18	23.19	26.20	24.20	0.2627
2	15	40	378000	1890	DFT-s-OFDM QPSK	1@214	22.88	23.1	26.00	24.00	0.2513
2	15	40	378000	1890	DFT-s-OFDM 16 QAM	108@54	22.3	22.26	25.29	23.29	0.2133
2	15	40	378000	1890	DFT-s-OFDM 16 QAM	1@1	22.47	22.53	25.51	23.51	0.2244
2	15	40	378000	1890	DFT-s-OFDM 16 QAM	1@214	22.26	22.36	25.32	23.32	0.2148
2	15	40	378000	1890	DFT-s-OFDM 64 QAM	108@54	20.25	20.19	23.23	21.23	0.1328
2	15	40	378000	1890	DFT-s-OFDM 64 QAM	1@1	20.34	20.49	23.43	21.43	0.1389
2	15	40	378000	1890	DFT-s-OFDM 64 QAM	1@214	20.2	20.44	23.33	21.33	0.1359
2	15	40	378000	1890	DFT-s-OFDM 256 QAM	108@54	17.74	17.59	20.68	18.68	0.0737
2	15	40	378000	1890	DFT-s-OFDM 256 QAM	1@1	17.67	17.71	20.70	18.70	0.0741
2	15	40	378000	1890	DFT-s-OFDM 256 QAM	1@214	17.47	17.69	20.59	18.59	0.0723
2	15	40	378000	1890	CP-OFDM QPSK	108@54	21.75	21.65	24.71	22.71	0.1867
2	15	40	378000	1890	CP-OFDM QPSK	1@1	21.88	22.01	24.96	22.96	0.1975
2	15	40	378000	1890	CP-OFDM QPSK	1@214	21.63	21.69	24.67	22.67	0.1849
2	15	5	370500	1852.5	DFT-s-OFDM PI/2 BPSK	1@1	23.12	23.11	26.13	24.13	0.2585
2	15	5	370500	1852.5	DFT-s-OFDM QPSK	1@1	23.05	23.12	26.10	24.10	0.2568
2	15	5	370500	1852.5	DFT-s-OFDM 16 QAM	1@1	22.43	22.45	25.45	23.45	0.2213
2	15	5	376000	1880	DFT-s-OFDM PI/2 BPSK	1@1	22.99	22.82	25.92	23.92	0.2464
2	15	5	376000	1880	DFT-s-OFDM QPSK	1@1	22.88	22.92	25.91	23.91	0.2461
2	15	5	376000	1880	DFT-s-OFDM 16 QAM	1@1	22.29	22.22	25.27	23.27	0.2121
2	15	5	381500	1907.5	DFT-s-OFDM PI/2 BPSK	1@1	22.78	22.91	25.86	23.86	0.2430
2	15	5	381500	1907.5	DFT-s-OFDM QPSK	1@1	22.77	22.93	25.86	23.86	0.2433
2	15	5	381500	1907.5	DFT-s-OFDM 16 QAM	1@1	22.16	22.27	25.23	23.23	0.2102
2	15	10	371000	1855	DFT-s-OFDM PI/2 BPSK	1@1	23.04	23.08	26.07	24.07	0.2553
2	15	10	371000	1855	DFT-s-OFDM QPSK	1@1	23.07	23.22	26.16	24.16	0.2604
2	15	10	371000	1855	DFT-s-OFDM 16 QAM	1@1	22.42	22.41	25.43	23.43	0.2201
2	15	10	376000	1880	DFT-s-OFDM PI/2 BPSK	1@1	23	23.1	26.06	24.06	0.2547
2	15	10	376000	1880	DFT-s-OFDM QPSK	1@1	22.98	22.92	25.96	23.96	0.2489
2	15	10	376000	1880	DFT-s-OFDM 16 QAM	1@1	22.33	22.26	25.31	23.31	0.2141
2	15	10	381000	1905	DFT-s-OFDM PI/2 BPSK	1@1	22.82	22.76	25.80	23.80	0.2399
2	15	10	381000	1905	DFT-s-OFDM QPSK	1@1	22.76	22.91	25.85	23.85	0.2424
2	15	10	381000	1905	DFT-s-OFDM 16 QAM	1@1	22.16	22.25	25.22	23.22	0.2097
2	15	15	371500	1857.5	DFT-s-OFDM PI/2 BPSK	1@1	23.05	23.09	26.08	24.08	0.2559
2	15	15	371500	1857.5	DFT-s-OFDM QPSK	1@1	23.02	23.25	26.15	24.15	0.2598
2	15	15	371500	1857.5	DFT-s-OFDM 16 QAM	1@1	22.39	22.49	25.45	23.45	0.2213
2	15	15	376000	1880	DFT-s-OFDM PI/2 BPSK	1@1	23.01	23.15	26.09	24.09	0.2565
2	15	15	376000	1880	DFT-s-OFDM QPSK	1@1	22.9	23.09	26.01	24.01	0.2516



2	15	15	376000	1880	DFT-s-OFDM 16 QAM	1@1	22.33	22.42	25.39	23.39	0.2180
2	15	15	380500	1902.5	DFT-s-OFDM PI/2 BPSK	1@1	22.88	22.85	25.88	23.88	0.2441
2	15	15	380500	1902.5	DFT-s-OFDM QPSK	1@1	22.83	22.84	25.85	23.85	0.2424
2	15	15	380500	1902.5	DFT-s-OFDM 16 QAM	1@1	22.2	22.25	25.24	23.24	0.2106
2	15	20	372000	1860	DFT-s-OFDM PI/2 BPSK	1@1	22.96	23.1	26.04	24.04	0.2536
2	15	20	372000	1860	DFT-s-OFDM QPSK	1@1	23	23.22	26.12	24.12	0.2583
2	15	20	372000	1860	DFT-s-OFDM 16 QAM	1@1	22.36	22.51	25.45	23.45	0.2211
2	15	20	376000	1880	DFT-s-OFDM PI/2 BPSK	1@1	23.02	23.17	26.11	24.11	0.2574
2	15	20	376000	1880	DFT-s-OFDM QPSK	1@1	22.9	23.15	26.04	24.04	0.2533
2	15	20	376000	1880	DFT-s-OFDM 16 QAM	1@1	22.24	22.44	25.35	23.35	0.2163
2	15	20	380000	1900	DFT-s-OFDM PI/2 BPSK	1@1	22.96	22.86	25.92	23.92	0.2466
2	15	20	380000	1900	DFT-s-OFDM QPSK	1@1	22.84	22.79	25.83	23.83	0.2413
2	15	20	380000	1900	DFT-s-OFDM 16 QAM	1@1	22.21	22.21	25.22	23.22	0.2099
2	15	25	372500	1862.5	DFT-s-OFDM PI/2 BPSK	1@1	23.09	23.18	26.15	24.15	0.2597
2	15	25	372500	1862.5	DFT-s-OFDM QPSK	1@1	23.07	23.34	26.22	24.22	0.2641
2	15	25	372500	1862.5	DFT-s-OFDM 16 QAM	1@1	22.51	22.49	25.51	23.51	0.2244
2	15	25	376000	1880	DFT-s-OFDM PI/2 BPSK	1@1	23.02	23.24	26.14	24.14	0.2595
2	15	25	376000	1880	DFT-s-OFDM QPSK	1@1	22.95	23.21	26.09	24.09	0.2566
2	15	25	376000	1880	DFT-s-OFDM 16 QAM	1@1	22.4	22.47	25.45	23.45	0.2211
2	15	25	379500	1897.5	DFT-s-OFDM PI/2 BPSK	1@1	22.97	22.85	25.92	23.92	0.2466
2	15	25	379500	1897.5	DFT-s-OFDM QPSK	1@1	22.98	23.01	26.01	24.01	0.2515
2	15	25	379500	1897.5	DFT-s-OFDM 16 QAM	1@1	22.34	22.25	25.31	23.31	0.2141
2	15	30	373000	1865	DFT-s-OFDM PI/2 BPSK	1@1	23.09	23.21	26.16	24.16	0.2607
2	15	30	373000	1865	DFT-s-OFDM QPSK	1@1	23.03	23.34	26.20	24.20	0.2629
2	15	30	373000	1865	DFT-s-OFDM 16 QAM	1@1	22.47	22.53	25.51	23.51	0.2244
2	15	30	376000	1880	DFT-s-OFDM PI/2 BPSK	1@1	23.07	23.25	26.17	24.17	0.2613
2	15	30	376000	1880	DFT-s-OFDM QPSK	1@1	22.96	23.31	26.15	24.15	0.2599
2	15	30	376000	1880	DFT-s-OFDM 16 QAM	1@1	22.3	22.46	25.39	23.39	0.2183
2	15	30	379000	1895	DFT-s-OFDM PI/2 BPSK	1@1	23.1	22.89	26.01	24.01	0.2516
2	15	30	379000	1895	DFT-s-OFDM QPSK	1@1	23.13	23.02	26.09	24.09	0.2562
2	15	30	379000	1895	DFT-s-OFDM 16 QAM	1@1	22.37	22.26	25.33	23.33	0.2151
2	15	35	373500	1867.5	DFT-s-OFDM PI/2 BPSK	1@1	23.02	23.17	26.11	24.11	0.2574
2	15	35	373500	1867.5	DFT-s-OFDM QPSK	1@1	23.08	23.26	26.18	24.18	0.2619
2	15	35	373500	1867.5	DFT-s-OFDM 16 QAM	1@1	22.32	22.57	25.46	23.46	0.2217
2	15	35	376000	1880	DFT-s-OFDM PI/2 BPSK	1@1	23.04	23.2	26.13	24.13	0.2589
2	15	35	376000	1880	DFT-s-OFDM QPSK	1@1	22.99	23.17	26.09	24.09	0.2565
2	15	35	376000	1880	DFT-s-OFDM 16 QAM	1@1	22.3	22.51	25.42	23.42	0.2196
2	15	35	378500	1892.5	DFT-s-OFDM PI/2 BPSK	1@1	23.03	22.96	26.01	24.01	0.2515
2	15	35	378500	1892.5	DFT-s-OFDM QPSK	1@1	23.13	23.07	26.11	24.11	0.2577
2	15	35	378500	1892.5	DFT-s-OFDM 16 QAM	1@1	22.44	22.37	25.42	23.42	0.2196



FR1 N25_Main PA

Frequency Stability

NR Band	SCS (kHz)	Bandwidth (MHz)	Arfcn	Freq (MHz)	Modulation	RB	Deviation (ppm)	Verdict	Environment
25	15	20	376500	1882.5	DFT-s-OFDM QPSK	100@0	0.0034	PASS	NV
25	15	20	376500	1882.5	DFT-s-OFDM QPSK	100@0	-0.0016	PASS	LV
25	15	20	376500	1882.5	DFT-s-OFDM QPSK	100@0	0.0024	PASS	HV
25	15	20	376500	1882.5	DFT-s-OFDM QPSK	100@0	0.0019	PASS	-30°C
25	15	20	376500	1882.5	DFT-s-OFDM QPSK	100@0	0.0044	PASS	-20°C
25	15	20	376500	1882.5	DFT-s-OFDM QPSK	100@0	-0.0027	PASS	-10°C
25	15	20	376500	1882.5	DFT-s-OFDM QPSK	100@0	0.0016	PASS	0°C
25	15	20	376500	1882.5	DFT-s-OFDM QPSK	100@0	-0.0025	PASS	10°C
25	15	20	376500	1882.5	DFT-s-OFDM QPSK	100@0	-0.0013	PASS	20°C
25	15	20	376500	1882.5	DFT-s-OFDM QPSK	100@0	-0.0044	PASS	30°C
25	15	20	376500	1882.5	DFT-s-OFDM QPSK	100@0	0.0037	PASS	40°C
25	15	20	376500	1882.5	DFT-s-OFDM QPSK	100@0	0.0029	PASS	50°C



Peak to Average Ratio

NR Band	SCS (kHz)	Bandwidth (MHz)	Arfcn	Freq (MHz)	Modulation	RB	Result (dB)	Limit (dB)	Verdict
25	15	20	376500	1882.5	DFT-s-OFDM PI/2 BPSK	100@0	4.61	13	PASS
25	15	20	376500	1882.5	DFT-s-OFDM PI/2 BPSK	1@0	4.23	13	PASS
25	15	20	376500	1882.5	DFT-s-OFDM QPSK	100@0	5.76	13	PASS
25	15	20	376500	1882.5	DFT-s-OFDM QPSK	1@0	6.24	13	PASS



N25(20M)_DFT-s-OFDM_PI_2-BPSK_Outer_Full_Mid_CH



N25(20M)_DFT-s-OFDM_PI_2-BPSK_Edge_1RB_Left_Mid_CH



N25(20M)_DFT-s-OFDM_QPSK_Outer_Full_Mid_CH



N25(20M)_DFT-s-OFDM_QPSK_Edge_1RB_Left_Mid_CH





Occupied Bandwidth

NR Band	SCS (kHz)	Bandwidth (MHz)	Arfcn	Freq (MHz)	Modulation	RB	OBW (MHz)	26dB BW (MHz)
25	15	5	376500	1882.5	CP-OFDM QPSK	25@0	4.4716	5.01
25	15	5	376500	1882.5	CP-OFDM 16 QAM	25@0	4.4685	5.061
25	15	5	376500	1882.5	CP-OFDM 64 QAM	25@0	4.4694	5.027
25	15	5	376500	1882.5	CP-OFDM 256 QAM	25@0	4.477	5.005
25	15	10	376500	1882.5	CP-OFDM QPSK	52@0	9.2822	10.1
25	15	10	376500	1882.5	CP-OFDM 16 QAM	52@0	9.2938	9.966
25	15	10	376500	1882.5	CP-OFDM 64 QAM	52@0	9.2533	9.835
25	15	10	376500	1882.5	CP-OFDM 256 QAM	52@0	9.2759	10.0
25	15	15	376500	1882.5	CP-OFDM QPSK	79@0	14.08	14.8
25	15	15	376500	1882.5	CP-OFDM 16 QAM	79@0	14.102	14.91
25	15	15	376500	1882.5	CP-OFDM 64 QAM	79@0	14.106	14.81
25	15	15	376500	1882.5	CP-OFDM 256 QAM	79@0	14.096	14.78
25	15	20	376500	1882.5	CP-OFDM QPSK	106@0	18.917	19.81
25	15	20	376500	1882.5	CP-OFDM 16 QAM	106@0	18.931	19.92
25	15	20	376500	1882.5	CP-OFDM 64 QAM	106@0	18.918	19.67
25	15	20	376500	1882.5	CP-OFDM 256 QAM	106@0	18.913	19.71
25	15	25	376500	1882.5	CP-OFDM QPSK	133@0	23.699	24.84
25	15	25	376500	1882.5	CP-OFDM 16 QAM	133@0	23.724	24.86
25	15	25	376500	1882.5	CP-OFDM 64 QAM	133@0	23.797	24.93
25	15	25	376500	1882.5	CP-OFDM 256 QAM	133@0	23.707	24.81
25	15	30	376500	1882.5	CP-OFDM QPSK	160@0	28.562	29.62
25	15	30	376500	1882.5	CP-OFDM 16 QAM	160@0	28.569	29.53
25	15	30	376500	1882.5	CP-OFDM 64 QAM	160@0	28.585	29.67



25	15	30	376500	1882.5	CP-OFDM 256 QAM	160@0	28.59	29.78
25	15	35	376500	1882.5	CP-OFDM QPSK	188@0	33.441	34.76
25	15	35	376500	1882.5	CP-OFDM 16 QAM	188@0	33.447	34.82
25	15	35	376500	1882.5	CP-OFDM 64 QAM	188@0	33.484	34.89
25	15	35	376500	1882.5	CP-OFDM 256 QAM	188@0	33.508	34.84
25	15	40	376500	1882.5	CP-OFDM QPSK	216@0	38.491	39.89
25	15	40	376500	1882.5	CP-OFDM 16 QAM	216@0	38.526	39.84
25	15	40	376500	1882.5	CP-OFDM 64 QAM	216@0	38.59	39.89
25	15	40	376500	1882.5	CP-OFDM 256 QAM	216@0	38.484	39.79



N25(5M)_CP-OFDM_QPSK_Outer_Full_Mid_CH

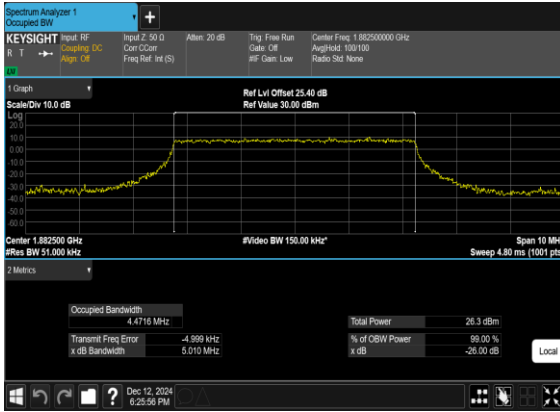

N25(5M)_CP-OFDM_16QAM_Outer_Full_Mid_CH



N25(5M)_CP-OFDM_64QAM_Outer_Full_Mid_CH



N25(5M)_CP-OFDM_256QAM_Outer_Full_Mid_CH

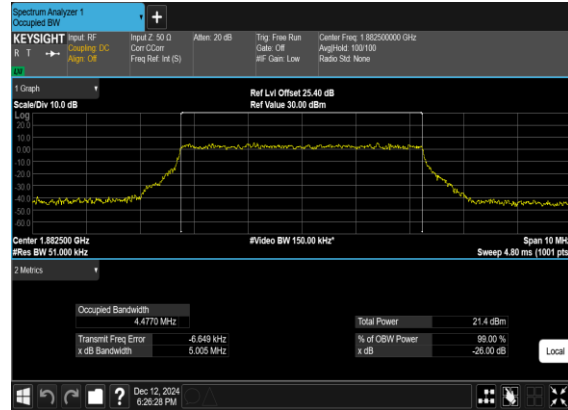



N25(10M)_CP-OFDM_QPSK_Outer_Full_Mid_CH

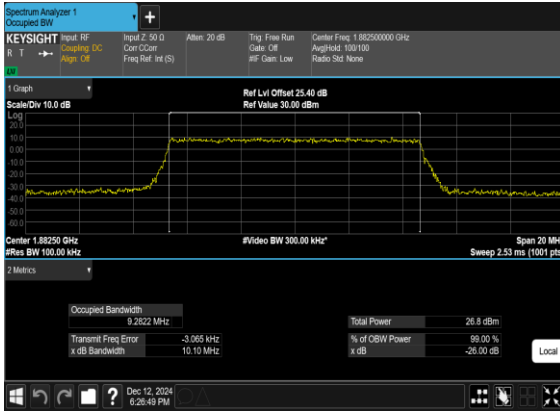

N25(10M)_CP-OFDM_16QAM_Outer_Full_Mid_CH

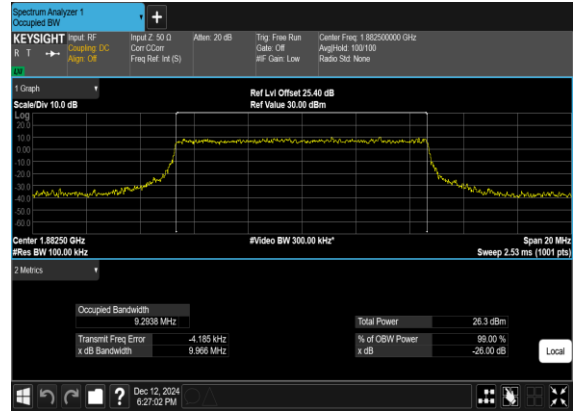

N25(10M)_CP-OFDM_64QAM_Outer_Full_Mid_CH



N25(10M)_CP-OFDM_256QAM_Outer_Full_Mid_CH

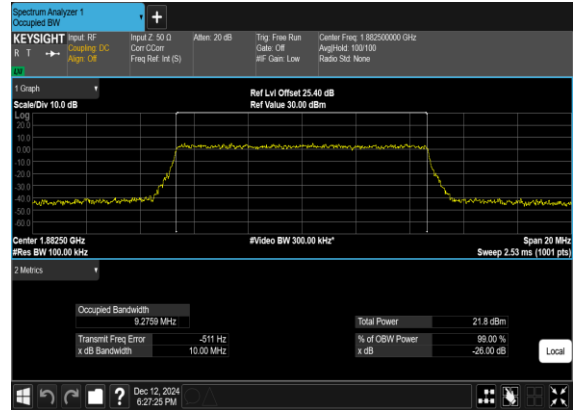



N25(15M)_CP-OFDM_QPSK_Outer_Full_Mid_CH



N25(15M)_CP-OFDM_16QAM_Outer_Full_Mid_CH

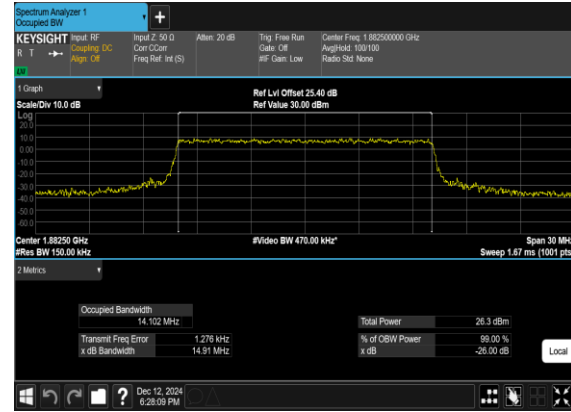

N25(15M)_CP-OFDM_64QAM_Outer_Full_Mid_CH

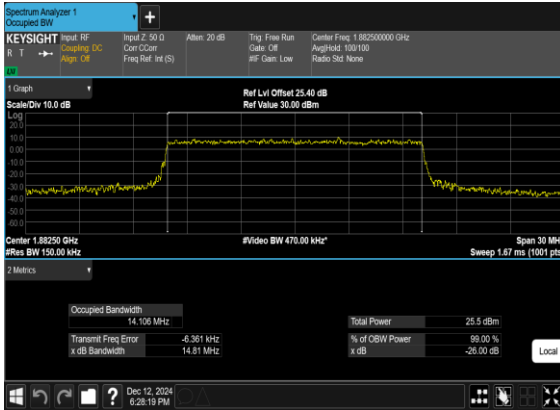

N25(15M)_CP-OFDM_256QAM_Outer_Full_Mid_CH

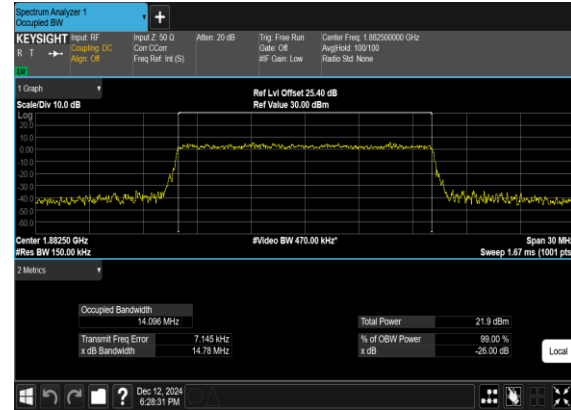



N25(20M)_CP-OFDM_QPSK_Outer_Full_Mid_CH



N25(20M)_CP-OFDM_16QAM_Outer_Full_Mid_CH

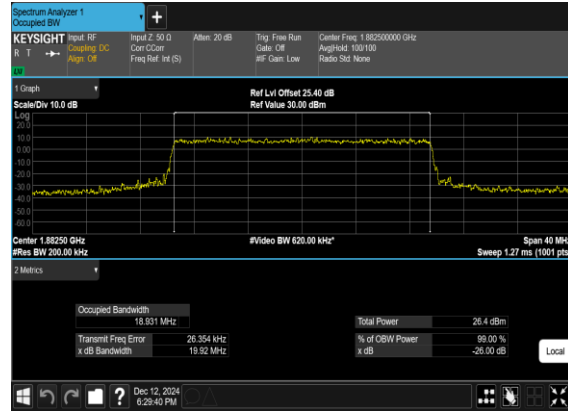

N25(20M)_CP-OFDM_64QAM_Outer_Full_Mid_CH

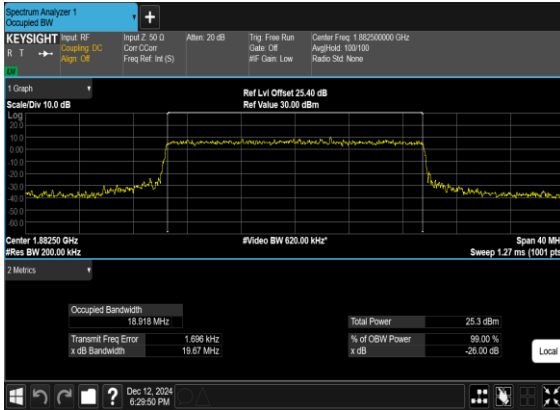

N25(20M)_CP-OFDM_256QAM_Outer_Full_Mid_CH

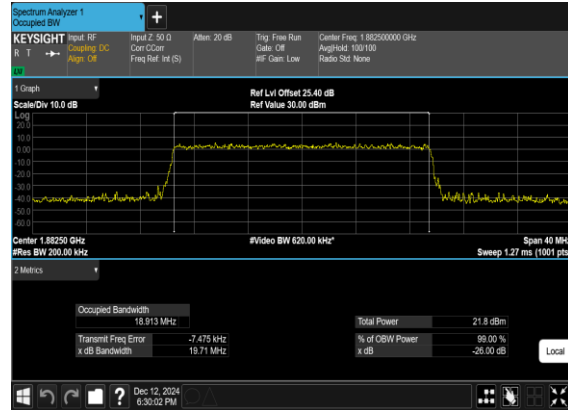



N25(25M)_CP-OFDM_QPSK_Outer_Full_Mid_CH

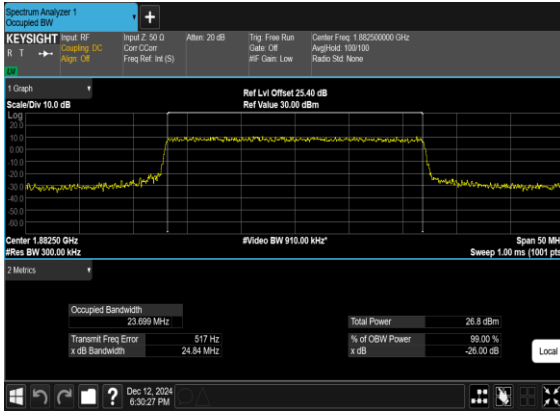

N25(25M)_CP-OFDM_16QAM_Outer_Full_Mid_CH

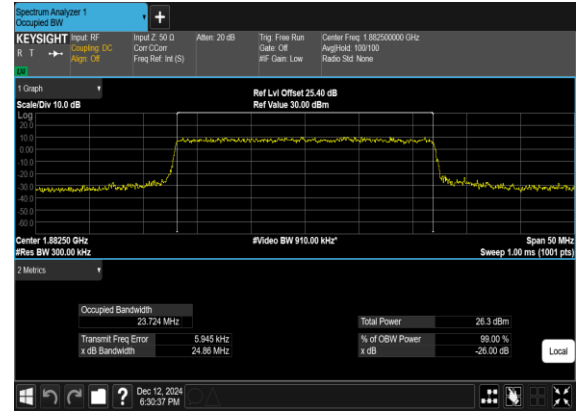

N25(25M)_CP-OFDM_64QAM_Outer_Full_Mid_CH

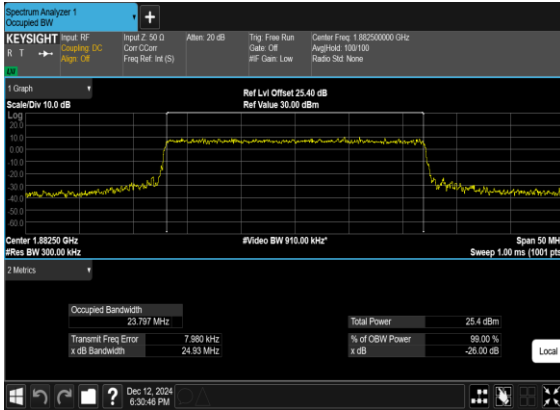

N25(25M)_CP-OFDM_256QAM_Outer_Full_Mid_CH

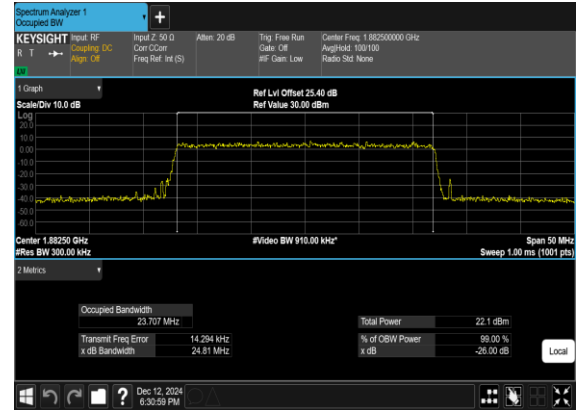



N25(30M)_CP-OFDM_QPSK_Outer_Full_Mid_CH

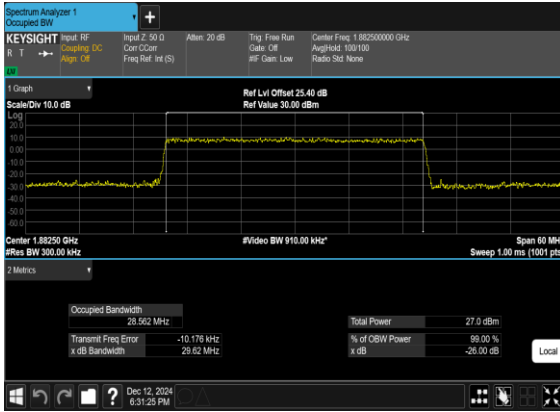

N25(30M)_CP-OFDM_16QAM_Outer_Full_Mid_CH



N25(30M)_CP-OFDM_64QAM_Outer_Full_Mid_CH

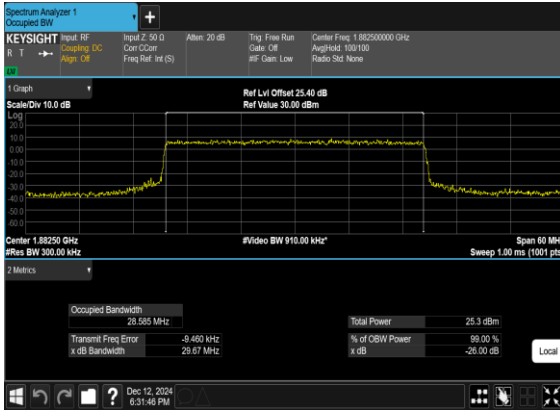

N25(30M)_CP-OFDM_256QAM_Outer_Full_Mid_CH

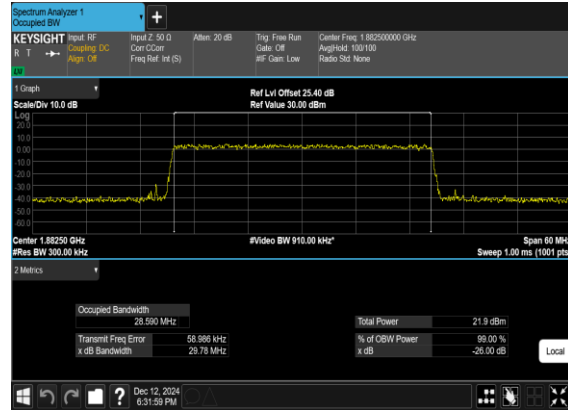



N25(35M)_CP-OFDM_QPSK_Outer_Full_Mid_CH

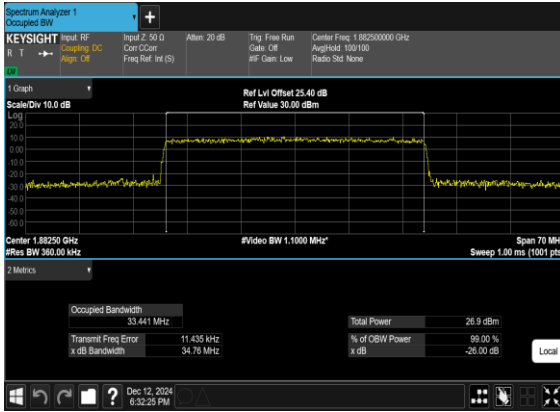

N25(35M)_CP-OFDM_16QAM_Outer_Full_Mid_CH

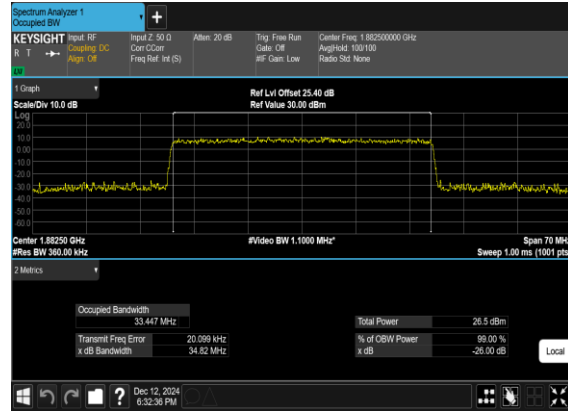

N25(35M)_CP-OFDM_64QAM_Outer_Full_Mid_CH

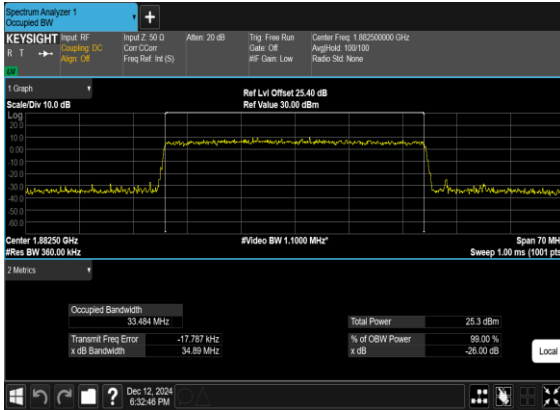

N25(35M)_CP-OFDM_256QAM_Outer_Full_Mid_CH

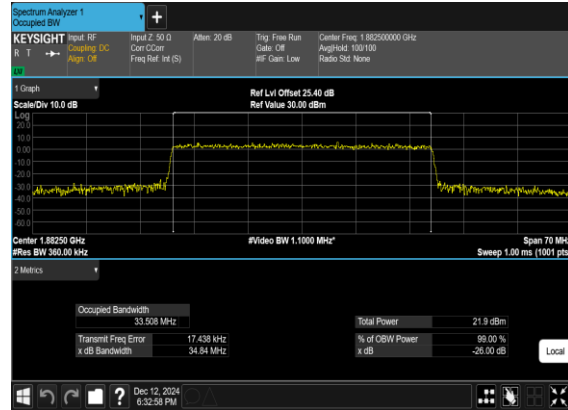



N25(40M)_CP-OFDM_QPSK_Outer_Full_Mid_CH

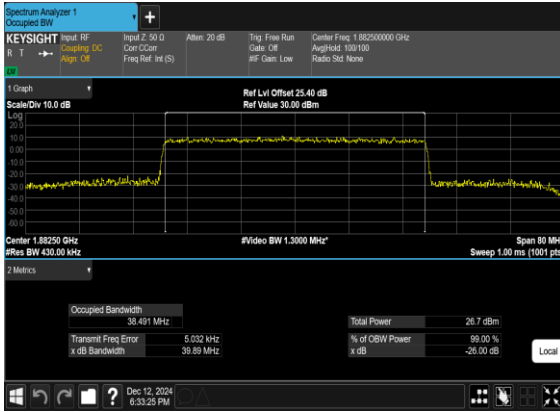

N25(40M)_CP-OFDM_16QAM_Outer_Full_Mid_CH

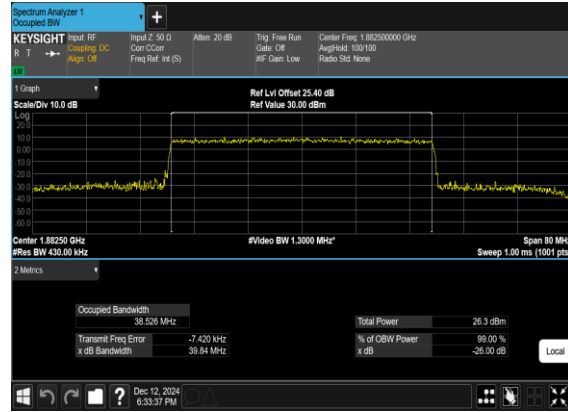

N25(40M)_CP-OFDM_64QAM_Outer_Full_Mid_CH

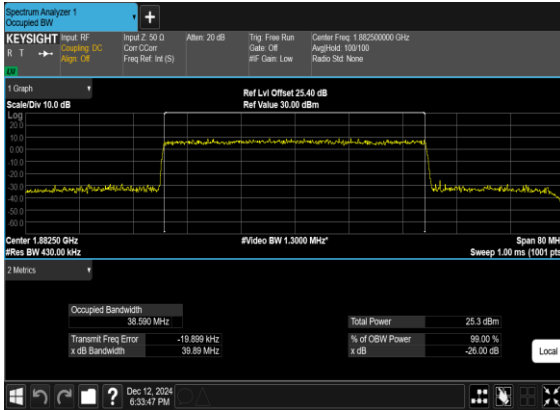

N25(40M)_CP-OFDM_256QAM_Outer_Full_Mid_CH

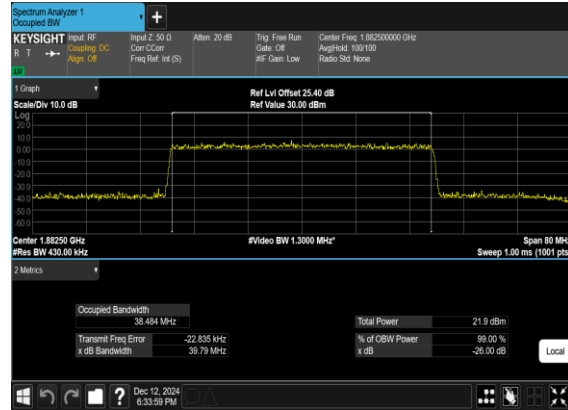



Conducted Spurious Emissions

NR Band	SCS (kHz)	Bandwidth (MHz)	Arfcn	Freq (MHz)	Modulation	RB	Result	Verdict
25	15	5	370500	1852.5	DFT-s-OFDM BPSK	1@0	see graph	---
25	15	5	370500	1852.5	DFT-s-OFDM BPSK	1@0	see graph	PASS
25	15	5	370500	1852.5	DFT-s-OFDM QPSK	1@0	see graph	---
25	15	5	370500	1852.5	DFT-s-OFDM QPSK	1@0	see graph	PASS
25	15	5	376500	1882.5	DFT-s-OFDM BPSK	1@0	see graph	---
25	15	5	376500	1882.5	DFT-s-OFDM BPSK	1@0	see graph	PASS
25	15	5	376500	1882.5	DFT-s-OFDM QPSK	1@0	see graph	---
25	15	5	376500	1882.5	DFT-s-OFDM QPSK	1@0	see graph	PASS
25	15	5	382500	1912.5	DFT-s-OFDM BPSK	1@0	see graph	---
25	15	5	382500	1912.5	DFT-s-OFDM BPSK	1@0	see graph	PASS
25	15	5	382500	1912.5	DFT-s-OFDM QPSK	1@0	see graph	---
25	15	5	382500	1912.5	DFT-s-OFDM QPSK	1@0	see graph	PASS
25	15	20	372000	1860.0	DFT-s-OFDM BPSK	1@0	see graph	---
25	15	20	372000	1860.0	DFT-s-OFDM BPSK	1@0	see graph	PASS
25	15	20	372000	1860.0	DFT-s-OFDM QPSK	1@0	see graph	---
25	15	20	372000	1860.0	DFT-s-OFDM QPSK	1@0	see graph	PASS
25	15	20	376500	1882.5	DFT-s-OFDM BPSK	1@0	see graph	---
25	15	20	376500	1882.5	DFT-s-OFDM BPSK	1@0	see graph	PASS
25	15	20	376500	1882.5	DFT-s-OFDM QPSK	1@0	see graph	---
25	15	20	376500	1882.5	DFT-s-OFDM QPSK	1@0	see graph	PASS



25	15	20	381000	1905.0	DFT-s-OFDM BPSK	1@0	see graph	---
25	15	20	381000	1905.0	DFT-s-OFDM BPSK	1@0	see graph	PASS
25	15	20	381000	1905.0	DFT-s-OFDM QPSK	1@0	see graph	---
25	15	20	381000	1905.0	DFT-s-OFDM QPSK	1@0	see graph	PASS
25	15	40	374000	1870.0	DFT-s-OFDM BPSK	1@0	see graph	---
25	15	40	374000	1870.0	DFT-s-OFDM BPSK	1@0	see graph	PASS
25	15	40	374000	1870.0	DFT-s-OFDM QPSK	1@0	see graph	---
25	15	40	374000	1870.0	DFT-s-OFDM QPSK	1@0	see graph	PASS
25	15	40	376500	1882.5	DFT-s-OFDM BPSK	1@0	see graph	---
25	15	40	376500	1882.5	DFT-s-OFDM BPSK	1@0	see graph	PASS
25	15	40	376500	1882.5	DFT-s-OFDM QPSK	1@0	see graph	---
25	15	40	376500	1882.5	DFT-s-OFDM QPSK	1@0	see graph	PASS
25	15	40	379000	1895.0	DFT-s-OFDM BPSK	1@0	see graph	---
25	15	40	379000	1895.0	DFT-s-OFDM BPSK	1@0	see graph	PASS
25	15	40	379000	1895.0	DFT-s-OFDM QPSK	1@0	see graph	---
25	15	40	379000	1895.0	DFT-s-OFDM QPSK	1@0	see graph	PASS



N25(5M)_DFT-s-OFDM_BPSK_Edge_1RB_Left_Low_CH

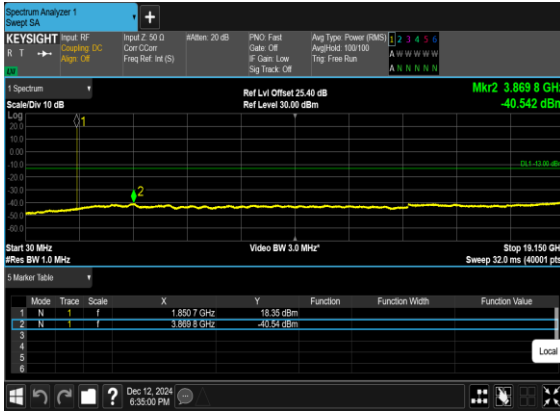

N25(5M)_DFT-s-OFDM_QPSK_Edge_1RB_Left_Low_CH

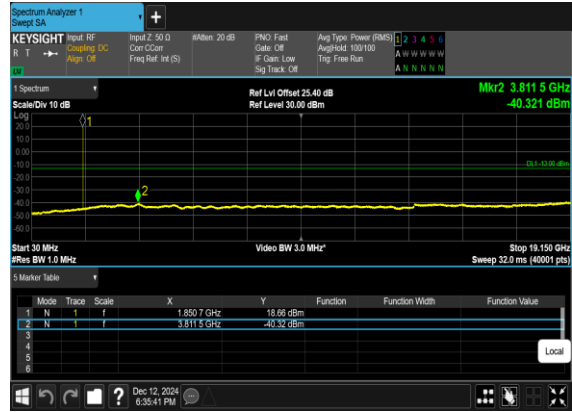

N25(5M)_DFT-s-OFDM_BPSK_Edge_1RB_Left_Mid_CH

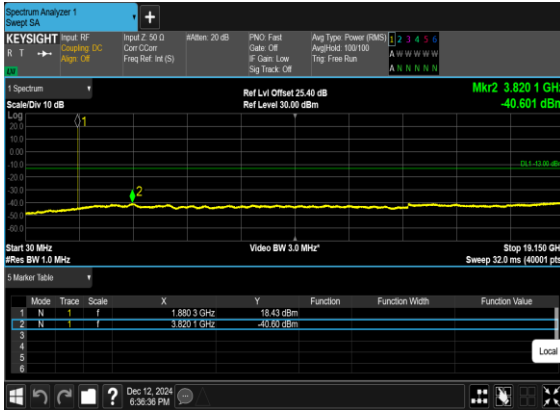

N25(5M)_DFT-s-OFDM_QPSK_Edge_1RB_Left_Mid_CH





N25(5M)_DFT-s-OFDM_BPSK_Edge_1RB_Left_High_CH

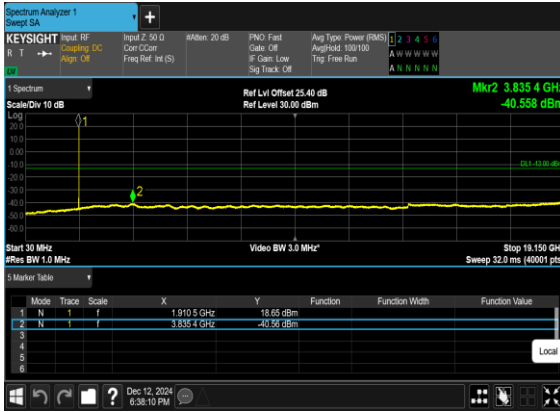

N25(5M)_DFT-s-OFDM_QPSK_Edge_1RB_Left_High_CH

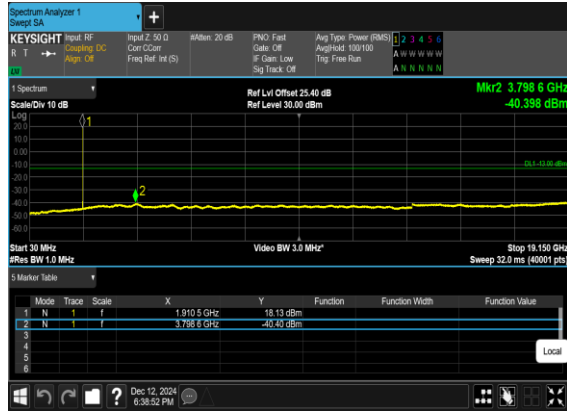

N25(20M)_DFT-s-OFDM_BPSK_Edge_1RB_Left_Low_CH

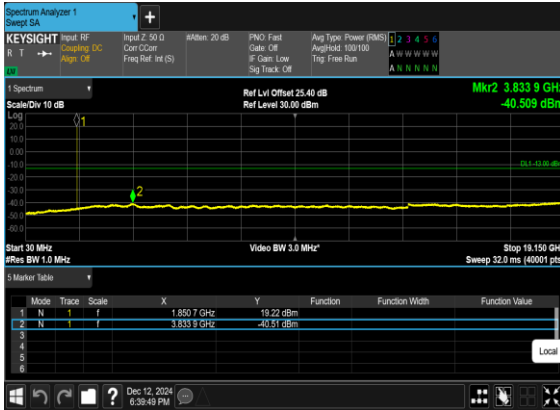

N25(20M)_DFT-s-OFDM_QPSK_Edge_1RB_Left_Low_CH

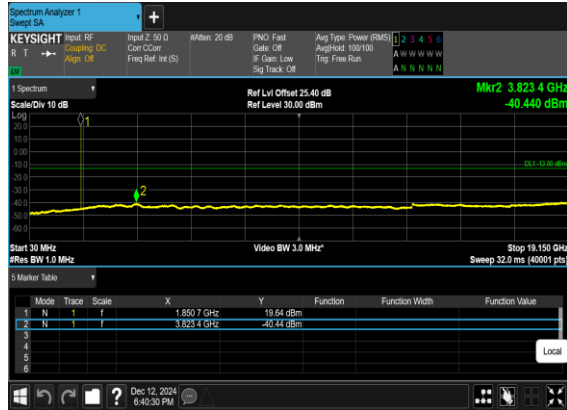



N25(20M)_DFT-s-OFDM_BPSK_Edge_1RB_Left_Mid_CH

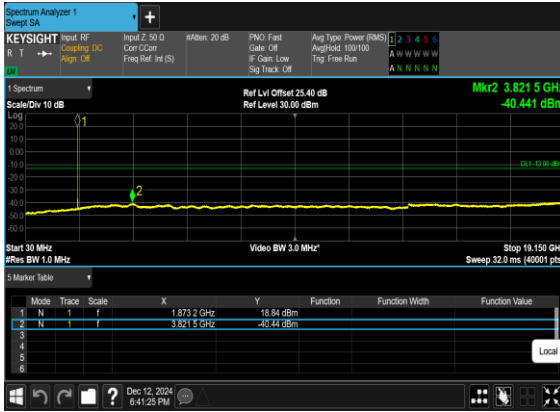

N25(20M)_DFT-s-OFDM_QPSK_Edge_1RB_Left_Mid_CH

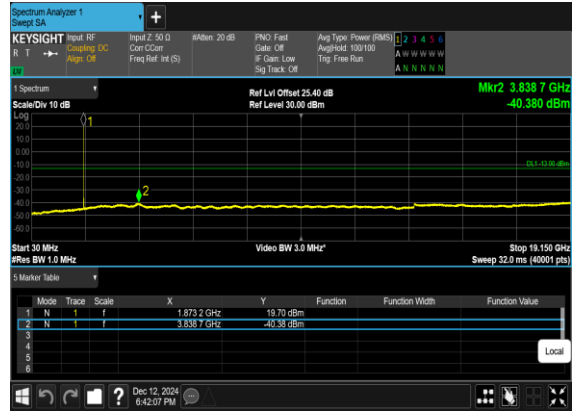

N25(20M)_DFT-s-OFDM_BPSK_Edge_1RB_Left_High_CH

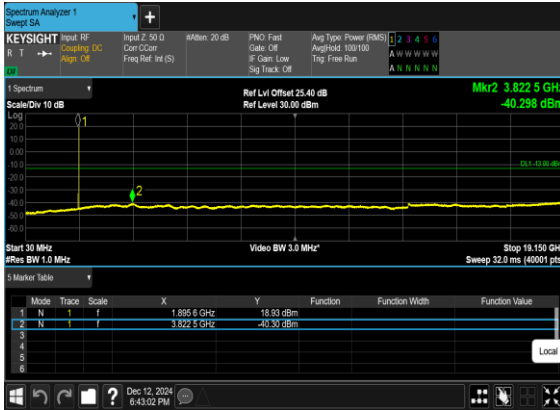

N25(20M)_DFT-s-OFDM_QPSK_Edge_1RB_Left_High_CH

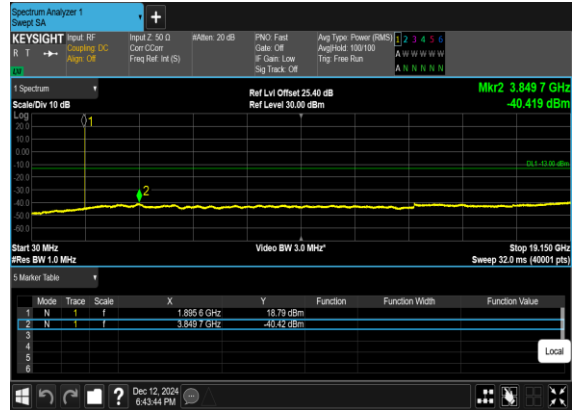



N25(40M)_DFT-s-OFDM_BPSK_Edge_1RB_Left_Low_CH

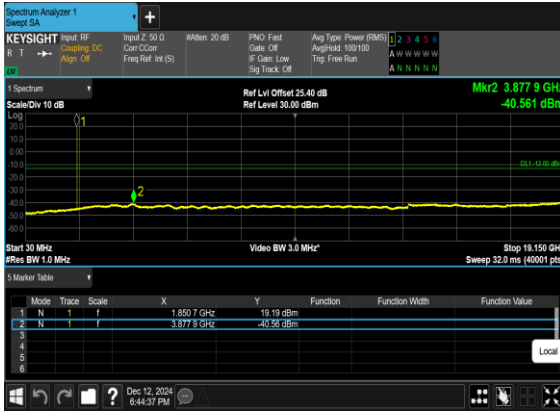

N25(40M)_DFT-s-OFDM_QPSK_Edge_1RB_Left_Low_CH

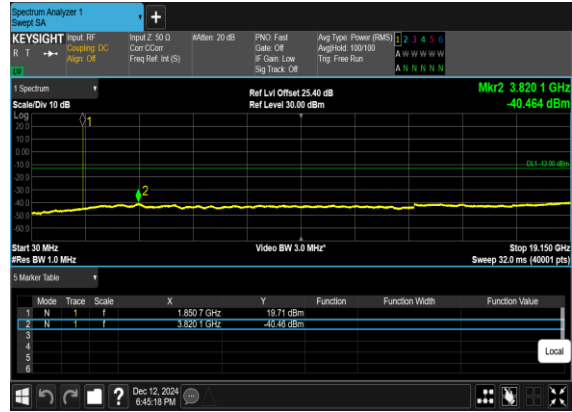

N25(40M)_DFT-s-OFDM_BPSK_Edge_1RB_Left_Mid_CH

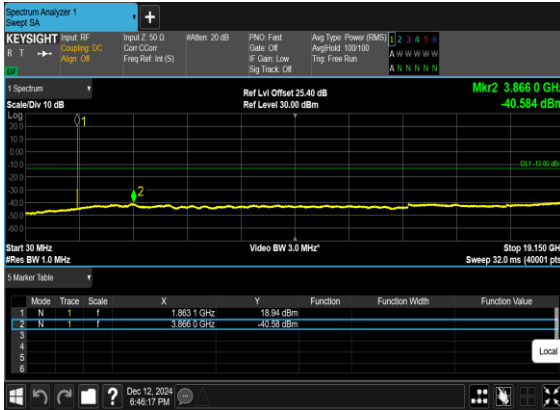

N25(40M)_DFT-s-OFDM_QPSK_Edge_1RB_Left_Mid_CH





N25(40M)_DFT-s-OFDM_BPSK_Edge_1RB_Left_High_CH

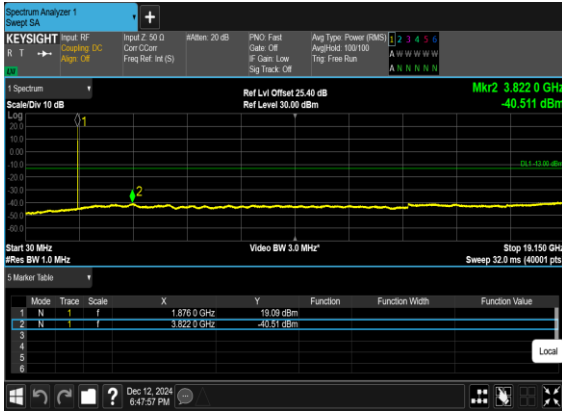

N25(40M)_DFT-s-OFDM_QPSK_Edge_1RB_Left_High_CH





Conducted Band Edge

NR Band	SCS (kHz)	Bandwidth (MHz)	Arfcn	Freq (MHz)	Modulation	RB	Result	Verdict
25	15	5	370500	1852.5	DFT-s-OFDM BPSK	1@0	see graph	PASS
25	15	5	370500	1852.5	DFT-s-OFDM QPSK	1@0	see graph	PASS
25	15	5	370500	1852.5	DFT-s-OFDM BPSK	25@0	see graph	PASS
25	15	5	370500	1852.5	DFT-s-OFDM QPSK	25@0	see graph	PASS
25	15	5	382500	1912.5	DFT-s-OFDM BPSK	1@24	see graph	PASS
25	15	5	382500	1912.5	DFT-s-OFDM QPSK	1@24	see graph	PASS
25	15	5	382500	1912.5	DFT-s-OFDM BPSK	25@0	see graph	PASS
25	15	5	382500	1912.5	DFT-s-OFDM QPSK	25@0	see graph	PASS
25	15	20	372000	1860.0	DFT-s-OFDM BPSK	1@0	see graph	PASS
25	15	20	372000	1860.0	DFT-s-OFDM QPSK	1@0	see graph	PASS
25	15	20	372000	1860.0	DFT-s-OFDM BPSK	100@0	see graph	PASS
25	15	20	372000	1860.0	DFT-s-OFDM QPSK	100@0	see graph	PASS
25	15	20	381000	1905.0	DFT-s-OFDM BPSK	1@105	see graph	PASS
25	15	20	381000	1905.0	DFT-s-OFDM QPSK	1@105	see graph	PASS
25	15	20	381000	1905.0	DFT-s-OFDM BPSK	100@0	see graph	PASS
25	15	20	381000	1905.0	DFT-s-OFDM QPSK	100@0	see graph	PASS
25	15	40	374000	1870.0	DFT-s-OFDM BPSK	1@0	see graph	PASS
25	15	40	374000	1870.0	DFT-s-OFDM QPSK	1@0	see graph	PASS
25	15	40	374000	1870.0	DFT-s-OFDM BPSK	216@0	see graph	PASS
25	15	40	374000	1870.0	DFT-s-OFDM QPSK	216@0	see graph	PASS



25	15	40	379000	1895.0	DFT-s-OFDM BPSK	1@215	see graph	PASS
25	15	40	379000	1895.0	DFT-s-OFDM QPSK	1@215	see graph	PASS
25	15	40	379000	1895.0	DFT-s-OFDM BPSK	216@0	see graph	PASS
25	15	40	379000	1895.0	DFT-s-OFDM QPSK	216@0	see graph	PASS



N25(5M)_DFT-s-OFDM_BPSK_Edge_1RB_Left_Low_CH



N25(5M)_DFT-s-OFDM_QPSK_Edge_1RB_Left_Low_CH

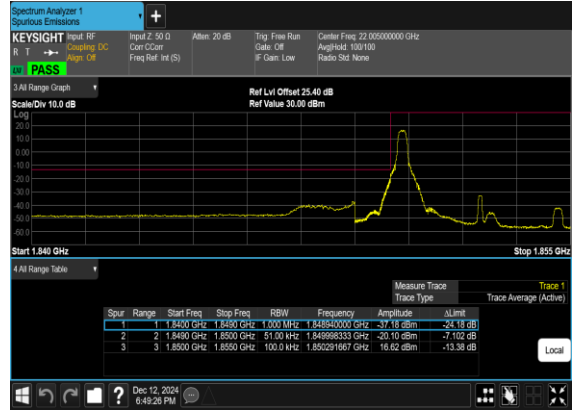

N25(5M)_DFT-s-OFDM_BPSK_Outer_Full_Low_CH

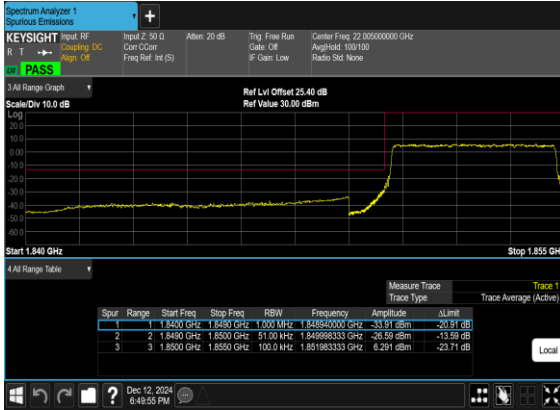

N25(5M)_DFT-s-OFDM_QPSK_Outer_Full_Low_CH

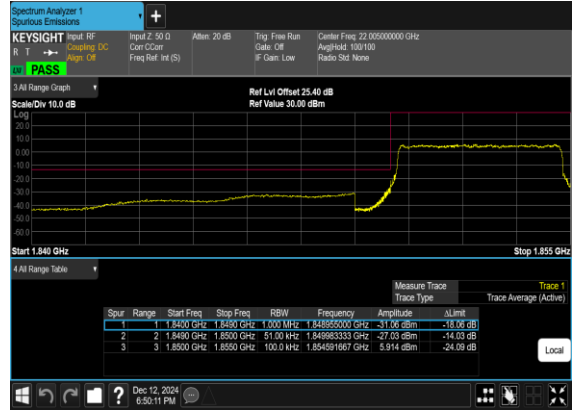



N25(5M)_DFT-s-OFDM_BPSK_Edge_1RB_Right_High_CH



N25(5M)_DFT-s-OFDM_QPSK_Edge_1RB_Right_High_CH

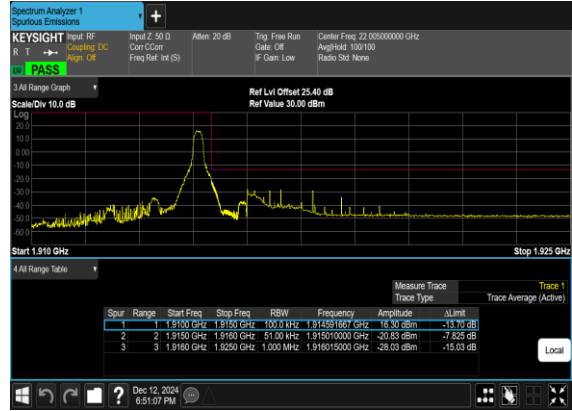

N25(5M)_DFT-s-OFDM_BPSK_Outer_Full_High_CH

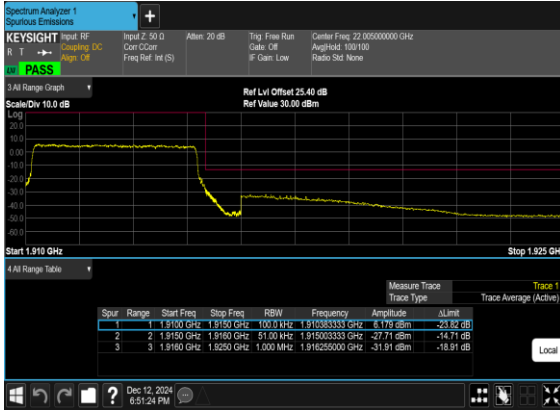

N25(5M)_DFT-s-OFDM_QPSK_Outer_Full_High_CH





N25(20M)_DFT-s-OFDM_BPSK_Edge_1RB_Left_Low_CH

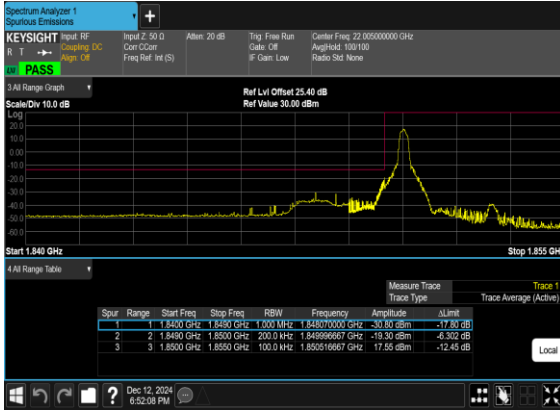

N25(20M)_DFT-s-OFDM_QPSK_Edge_1RB_Left_Low_CH

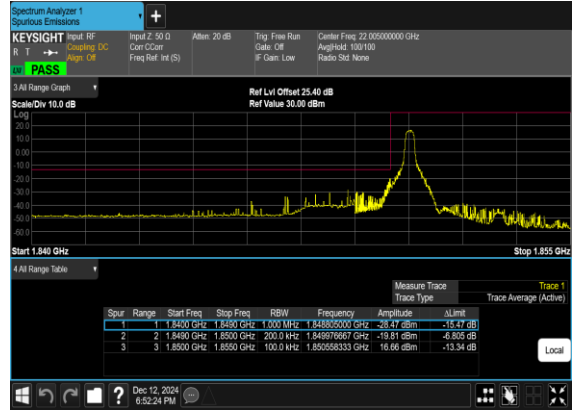

N25(20M)_DFT-s-OFDM_BPSK_Outer_Full_Low_CH

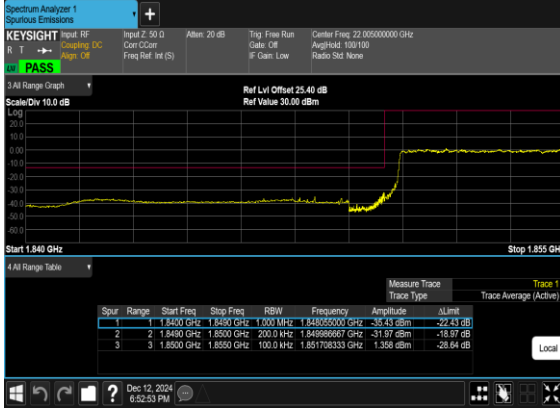

N25(20M)_DFT-s-OFDM_QPSK_Outer_Full_Low_CH

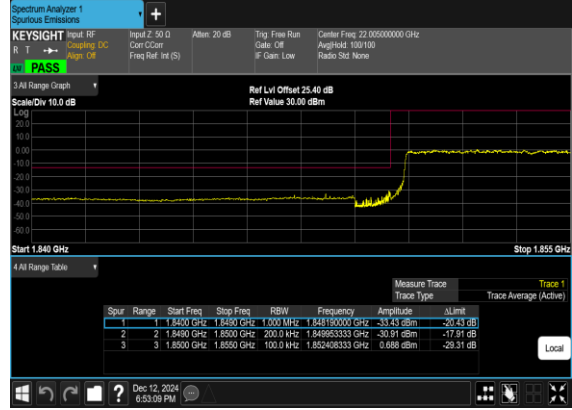



N25(20M)_DFT-s-OFDM_BPSK_Edge_1RB_Right_High_CH



N25(20M)_DFT-s-OFDM_QPSK_Edge_1RB_Right_High_CH

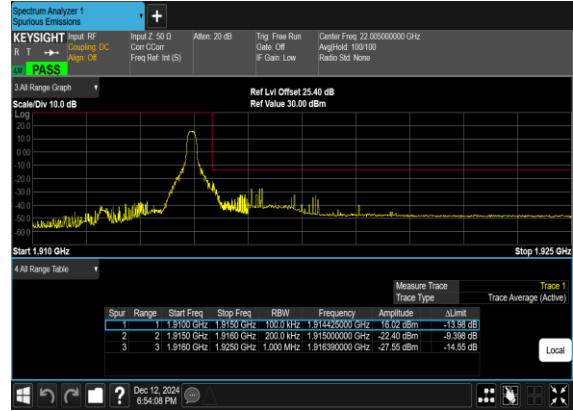

N25(20M)_DFT-s-OFDM_BPSK_Outer_Full_High_CH



N25(20M)_DFT-s-OFDM_QPSK_Outer_Full_High_CH

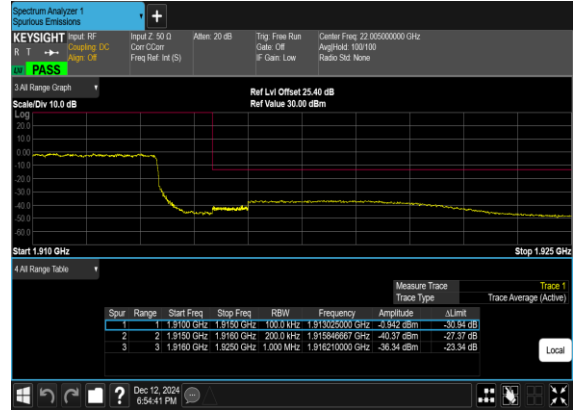



N25(40M)_DFT-s-OFDM_BPSK_Edge_1RB_Left_Low_CH

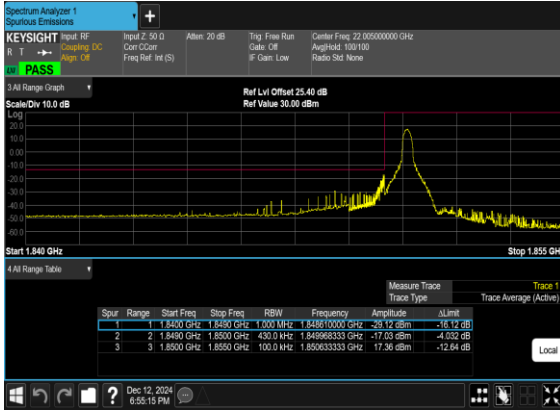

N25(40M)_DFT-s-OFDM_QPSK_Edge_1RB_Left_Low_CH

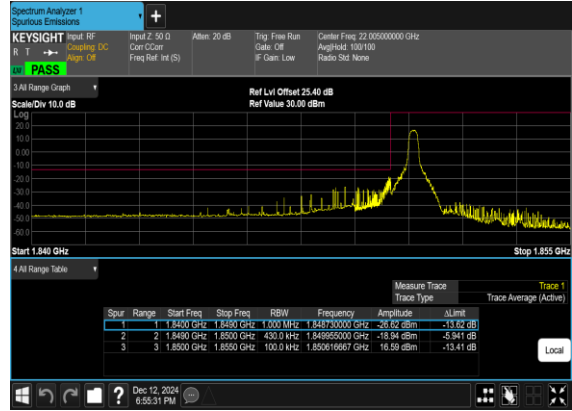

N25(40M)_DFT-s-OFDM_BPSK_Outer_Full_Low_CH

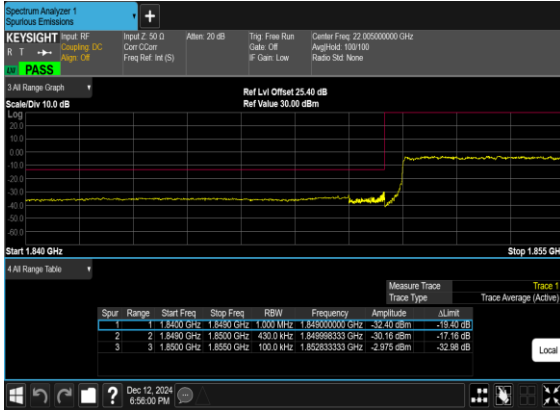

N25(40M)_DFT-s-OFDM_QPSK_Outer_Full_Low_CH

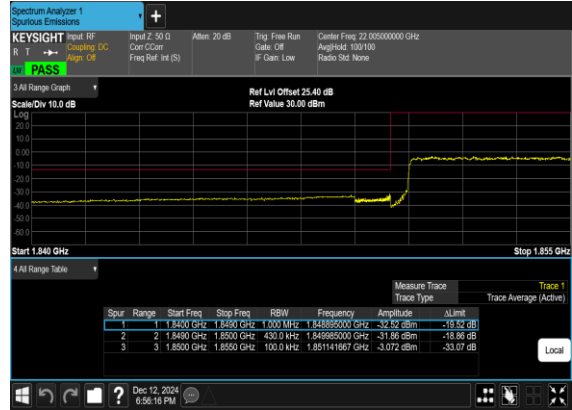



N25(40M)_DFT-s-OFDM_BPSK_Edge_1RB_Right_High_CH



N25(40M)_DFT-s-OFDM_QPSK_Edge_1RB_Right_High_CH

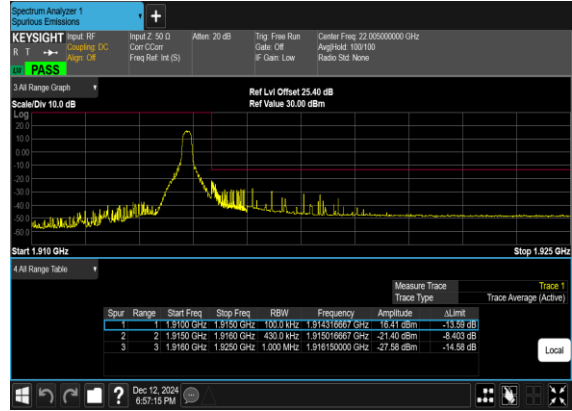

N25(40M)_DFT-s-OFDM_BPSK_Outer_Full_High_CH

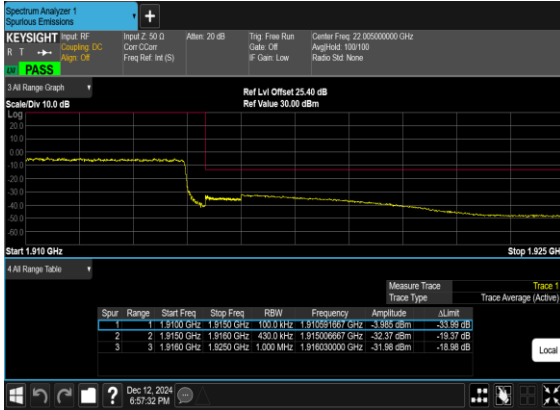

N25(40M)_DFT-s-OFDM_QPSK_Outer_Full_High_CH

