



FCC RF Test Report

APPLICANT : Motorola Mobility LLC
EQUIPMENT : Mobile Cellular Phone
BRAND NAME : Motorola
MODEL NAME : XT2551-1, XT2551-2, XT2551-6
FCC ID : IHDT56AU1
STANDARD : 47 CFR Part 27 Subpart Q
CLASSIFICATION : PCS Licensed Transmitter Held to Ear (PCE)
TEST DATE(S) : Dec. 11, 2024 ~ Dec. 31, 2024

We, Sporton International Inc. (KunShan), would like to declare that the tested sample has been evaluated in accordance with the procedures given in ANSI C63.26-2015 and shown compliance with the applicable technical standards.

The test results in this report apply exclusively to the tested model / sample. Without written approval of Sporton International Inc. (KunShan), the test report shall not be reproduced except in full.

Jason Jia

Approved by: Jason Jia



Sporton International Inc. (Kunshan)

No. 1098, Pengxi North Road, Kunshan Economic Development Zone Jiangsu Province 215300
People's Republic of China



TABLE OF CONTENTS

REVISION HISTORY..... 3
SUMMARY OF TEST RESULT 4
1 GENERAL DESCRIPTION 5
1.1 Applicant 5
1.2 Manufacturer 5
1.3 Product Feature of Equipment Under Test 5
1.4 Product Specification of Equipment Under Test 6
1.5 Modification of EUT 6
1.6 Maximum EIRP Power and Emission Designator 7
1.7 Testing Location 9
1.8 Test Software 9
1.9 Applied Standards 9
1.10 Specification of Accessory 10
2 TEST CONFIGURATION OF EQUIPMENT UNDER TEST 11
2.1 Test Mode 11
2.2 Connection Diagram of Test System 12
2.3 Support Unit used in test configuration and system 12
2.4 Measurement Results Explanation Example 12
2.5 Frequency List of Low/Middle/High Channels 13
3 CONDUCTED TEST ITEMS 14
3.1 Measuring Instruments 14
3.2 Test Setup 14
3.3 Test Result of Conducted Test 14
3.4 Conducted Output Power Measurement 15
3.5 Peak-to-Average Ratio 16
3.6 EIRP 17
3.7 Occupied Bandwidth 18
3.8 Conducted Band Edge Measurement 19
3.9 Conducted Spurious Emission Measurement 20
3.10 Frequency Stability Measurement 21
4 RADIATED TEST ITEMS 22
4.1 Measuring Instruments 22
4.2 Test Setup 22
4.3 Test Result of Radiated Test 23
4.4 Radiated Spurious Emission Measurement 24
5 LIST OF MEASURING EQUIPMENT 25
6 MEASUREMENT UNCERTAINTY 26
APPENDIX A. TEST RESULTS OF CONDUCTED TEST
APPENDIX B. TEST RESULTS OF RADIATED TEST
APPENDIX C. TEST SETUP PHOTOGRAPHS

SUMMARY OF TEST RESULT

Report Section	FCC Rule	Description	Limit	Result	Remark
3.4	§2.1046	Conducted Output Power	—	Report Only	-
3.5	§27.50 (k)(4)	Peak-to-Average Ratio	<13dB	PASS	
3.6	§27.50 (k)(3)	EIRP	EIRP < 1W (30dBm)	PASS	-
3.7	§2.1049	Occupied Bandwidth	—	Report Only	-
3.8	§2.1051 §27.53 (n)(2)	Conducted Band Edge Measurement	-13dBm/MHz	PASS	-
3.9	§2.1051 §27.53 (n)(2)	Conducted Spurious Emission	-13dBm/MHz	PASS	-
3.10	§2.1055 §27.54	Frequency Stability Temperature & Voltage	Within the band	PASS	-
4.4	§2.1053 §27.53 (n)(2)	Radiated Spurious Emission	-13dBm/MHz	PASS	Under limit 23.27 dB at 10356.000 MHz

Conformity Assessment Condition:

1. The test results (PASS/FAIL) with all measurement uncertainty excluded are presented against the regulation limits or in accordance with the requirements stipulated by the applicant/manufacturer who shall bear all the risks of non-compliance that may potentially occur if measurement uncertainty is taken into account.
2. The measurement uncertainty please refer to each test result in the section "Measurement Uncertainty"

Disclaimer:

The product specifications of the EUT presented in the test report that may affect the test assessments are declared by the manufacturer who shall take full responsibility for the authenticity.



1 General Description

1.1 Applicant

Motorola Mobility LLC
222 W,Merchandise Mart Plaza, Chicago IL 60654 USA

1.2 Manufacturer

Motorola Mobility LLC
222 W,Merchandise Mart Plaza, Chicago IL 60654 USA

1.3 Product Feature of Equipment Under Test

Product Feature	
Equipment	Mobile Cellular Phone
Brand Name	Motorola
Model Name	XT2551-1, XT2551-2, XT2551-6
FCC ID	IHDT56AU1
IMEI Code	Conducted : 350086570033998/350086570034004 Radiation : 350086570035852/350086570035860
HW Version	DVT2
SW Version	V2VL35.5
EUT Stage	Identical Prototype

Remark: The three models name XT2551-1, XT2551-2, XT2551-6 are the same product except model name different for market segment.

1.4 Product Specification of Equipment Under Test

Product Feature	
Tx/Rx Frequency	5G NR n77: 3450 MHz ~ 3550 MHz 5G NR n78: 3450 MHz ~ 3550 MHz
SCS	30kHz
Bandwidth	n77/n78: 10 / 15 / 20 / 25 / 30 / 40 / 50 / 60 / 70 / 80 / 90 / 100MHz
Antenna Gain	<Ant. 3> 5G NR n77/n78: -3.2 dBi <Ant. 4>5G NR n77/n78 : -0.9 dBi <Ant. 5>5G NR n77/n78: -5.4 dBi <Ant. 8>5G NR n77/n78: -3.0 dBi
Type of Modulation	CP-OFDM: QPSK / 16QAM / 64QAM / 256QAM DFT-s-OFDM: PI/2 BPSK / QPSK / 16QAM / 64QAM / 256QAM

Remark:

1. The maximum EIRP is calculated from max output power and max antenna gain, only the maximum EIRP is shown in the report, Ant.4 for n77/n78 SA mode and Ant(8+4) for n77/n78 MIMO mode.
2. 5G NR n77/n78 support SA and NSA mode. The whole conducted testing has assessed SA mode for n77 by referring to the higher conducted power.
3. 5G NR n77/n78 Single Carrier and 5G n78_UL MIMO support PC2 and 5G NR n77_UL MIMO mode is PC1.5.
4. The UL MIMO is completely uncorrelated, so the directional gain is selected the maximum gain among all antennas.
5. For UL MIMO mode, the conducted BE/Spurious are tested at single antenna port and add $10 \cdot \log(N_{ANT})$ according to KDB 662911 D01.
6. The device supports two Path for 5G NR n77/n78, we chose higher power of 1st Path to test.
7. The EN-DC mode combination could be referred to the product spec.

1.5 Modification of EUT

No modifications are made to the EUT during all test items.

1.6 Maximum EIRP Power and Emission Designator

5G NR n77 SA		PI/2 BPSK / QPSK		16QAM/64QAM/256QAM	
BW (MHz)	Frequency Range (MHz)	Maximum EIRP(W)	Emission Designator (99%OBW)	Maximum EIRP(W)	Emission Designator (99%OBW)
10	3455.01 ~ 3544.98	0.3698	8M57G7D	0.2438	8M57W7D
15	3457.50 ~ 3542.49	0.3758	13M6G7D	0.2477	13M6W7D
20	3460.02 ~ 3540.00	0.3673	18M2G7D	0.2477	18M3W7D
25	3462.51 ~ 3537.48	0.3990	23M2G7D	0.2529	23M3W7D
30	3465.00 ~ 3534.99	0.3837	27M7G7D	0.2535	27M9W7D
40	3470.01 ~ 3529.98	0.3707	37M9G7D	0.2443	37M9W7D
50	3475.02 ~ 3525.00	0.3855	47M5G7D	0.2606	47M6W7D
60	3480.00 ~ 3519.99	0.3784	58M0G7D	0.2443	57M9W7D
70	3485.01 ~ 3514.98	0.3855	67M4G7D	0.2649	67M6W7D
80	3490.02 ~ 3510.00	0.3917	77M4G7D	0.2588	77M6W7D
90	3495.00 ~ 3504.99	0.3936	87M4G7D	0.2564	87M5W7D
100	3500.01	0.3750	97M5G7D	0.2483	97M5W7D

5G NR n77 UL MIMO		PI/2 BPSK / QPSK		16QAM/64QAM/256QAM	
BW (MHz)	Frequency Range (MHz)	Maximum EIRP(W)	Emission Designator (99%OBW)	Maximum EIRP(W)	Emission Designator (99%OBW)
10	3455.01 ~ 3544.98	0.6354	8M58G7D	0.5397	8M60W7D
15	3457.50 ~ 3542.49	0.6296	13M6G7D	0.5297	13M6W7D
20	3460.02 ~ 3540.00	0.6224	18M2G7D	0.5316	18M2W7D
25	3462.51 ~ 3537.48	0.6420	23M2G7D	0.5471	23M2W7D
30	3465.00 ~ 3534.99	0.6450	27M8G7D	0.5427	27M9W7D
40	3470.01 ~ 3529.98	0.6235	37M8G7D	0.5226	37M9W7D
50	3475.02 ~ 3525.00	0.6686	47M6G7D	0.5554	47M7W7D
60	3480.00 ~ 3519.99	0.6542	58M0G7D	0.5422	57M9W7D
70	3485.01 ~ 3514.98	0.6685	67M4G7D	0.5663	67M5W7D
80	3490.02 ~ 3510.00	0.6625	77M5G7D	0.5569	77M6W7D
90	3495.00 ~ 3504.99	0.6678	87M6G7D	0.5739	87M7W7D
100	3500.01	0.6594	97M5G7D	0.5665	97M6W7D



5G NR n78 SA		PI/2 BPSK / QPSK		16QAM/64QAM/256QAM	
BW (MHz)	Frequency Range (MHz)	Maximum EIRP(W)	Emission Designator (99%OBW)	Maximum EIRP(W)	Emission Designator (99%OBW)
10	3455.01 ~ 3544.98	0.3724	8M57G7D	0.2323	8M57W7D
15	3457.50 ~ 3542.49	0.3664	13M6G7D	0.2280	13M6W7D
20	3460.02 ~ 3540.00	0.3639	18M2G7D	0.2239	18M3W7D
25	3462.51 ~ 3537.48	0.3707	23M2G7D	0.2333	23M3W7D
30	3465.00 ~ 3534.99	0.3741	27M7G7D	0.2323	27M9W7D
40	3470.01 ~ 3529.98	0.3664	37M9G7D	0.2254	37M9W7D
50	3475.02 ~ 3525.00	0.3767	47M5G7D	0.2339	47M6W7D
60	3480.00 ~ 3519.99	0.3597	58M0G7D	0.2270	57M9W7D
70	3485.01 ~ 3514.98	0.3715	67M4G7D	0.2333	67M6W7D
80	3490.02 ~ 3510.00	0.3828	77M4G7D	0.2404	77M6W7D
90	3495.00 ~ 3504.99	0.3917	87M4G7D	0.2438	87M5W7D
100	3500.01	0.3767	97M5G7D	0.2410	97M5W7D

5G NR n78 UL MIMO		PI/2 BPSK / QPSK		16QAM/64QAM/256QAM	
BW (MHz)	Frequency Range (MHz)	Maximum EIRP(W)	Emission Designator (99%OBW)	Maximum EIRP(W)	Emission Designator (99%OBW)
10	3455.01 ~ 3544.98	0.2795	8M58G7D	0.2381	8M60W7D
15	3457.50 ~ 3542.49	0.2762	13M6G7D	0.2373	13M6W7D
20	3460.02 ~ 3540.00	0.2742	18M2G7D	0.2321	18M2W7D
25	3462.51 ~ 3537.48	0.2875	23M2G7D	0.2380	23M2W7D
30	3465.00 ~ 3534.99	0.2888	27M8G7D	0.2425	27M9W7D
40	3470.01 ~ 3529.98	0.2721	37M8G7D	0.2335	37M9W7D
50	3475.02 ~ 3525.00	0.2879	47M6G7D	0.2453	47M7W7D
60	3480.00 ~ 3519.99	0.2820	58M0G7D	0.2402	57M9W7D
70	3485.01 ~ 3514.98	0.2921	67M4G7D	0.2472	67M5W7D
80	3490.02 ~ 3510.00	0.2915	77M5G7D	0.2487	77M6W7D
90	3495.00 ~ 3504.99	0.2942	87M6G7D	0.2487	87M7W7D
100	3500.01	0.3062	97M5G7D	0.2542	97M6W7D

Note:

- 5G NR Band n77 overlaps the entire frequency range of Band n78, and n77 power > n78 power, therefore the conducted test results of n77 provided in this report cover n78.
- All modulations have been tested, and only the worst test results of PSK & QAM are shown in the report.

1.7 Testing Location

Sporton International Inc. (Kunshan) is accredited to ISO/IEC 17025:2017 by American Association for Laboratory Accreditation with Certificate Number 5145.02.

Test Firm	Sporton International Inc. (Kunshan)		
Test Site Location	No. 1098, Pengxi North Road, Kunshan Economic Development Zone Jiangsu Province 215300 People's Republic of China TEL : +86-512-57900158		
Test Site No.	Sporton Site No.	FCC Designation No.	FCC Test Firm Registration No.
	TH01- KS 03CH04-KS	CN1257	314309

1.8 Test Software

Item	Site	Manufacture	Name	Version
1.	03CH04-KS	AUDIX	E3	210616

1.9 Applied Standards

According to the specifications of the manufacturer, the EUT must comply with the requirements of the following standards:

- ♦ 47 CFR Part 27 Subpart Q
- ♦ ANSI C63.26-2015
- ♦ FCC KDB 971168 Power Meas License Digital Systems D01 v03r01
- ♦ FCC KDB 412172 D01 Determining ERP and EIRP v01r01

Remark:

1. All test items were verified and recorded according to the standards and without any deviation during the test.
2. This EUT has also been tested and complied with the requirements of FCC Part 15, Subpart B, recorded in a separate test report.

1.10 Specification of Accessory

Accessories Information				
AC Adapter 1(US)	Brand Name	Motorola(Chenyang)	Model Name	MC-681N
AC Adapter 1(EU)	Brand Name	Motorola(Chenyang)	Model Name	MC-682N
AC Adapter 1(UK)	Brand Name	Motorola(Chenyang)	Model Name	MC-683N
AC Adapter 1(AU)	Brand Name	Motorola(Chenyang)	Model Name	MC-685N
AC Adapter 1(AR)	Brand Name	Motorola(Chenyang)	Model Name	MC-686N
AC Adapter 1(BR)	Brand Name	Motorola(Chenyang)	Model Name	MC-687N
AC Adapter 1(Chile)	Brand Name	Motorola(Chenyang)	Model Name	MC-689N
AC Adapter 2(US)	Brand Name	Motorola(Acbel)	Model Name	MC-681N
AC Adapter 2(EU)	Brand Name	Motorola(Acbel)	Model Name	MC-682N
AC Adapter 2(UK)	Brand Name	Motorola(Acbel)	Model Name	MC-683N
AC Adapter 2(AU)	Brand Name	Motorola(Acbel)	Model Name	MC-685N
AC Adapter 2(AR)	Brand Name	Motorola(Acbel)	Model Name	MC-686N
AC Adapter 2(BR)	Brand Name	Motorola(Acbel)	Model Name	MC-687N
Battery 1	Brand Name	Motorola(ATL)	Model Name	RS13
Battery 2	Brand Name	Motorola(ATL)	Model Name	RS35
USB Cable 1	Brand Name	Motorola(saibao)	Model Name	SC18D71644
USB Cable 2	Brand Name	Motorola(Luxshare)	Model Name	SC18E08104
USB Cable 3	Brand Name	Motorola(saibao)	Model Name	SC18D86731
USB Cable 4	Brand Name	Motorola(Luxshare)	Model Name	SC18E08103

2 Test Configuration of Equipment Under Test

2.1 Test Mode

Antenna port conducted and radiated test items listed below are performed according to KDB 971168 D01 Power Meas. License Digital Systems v03r01 with maximum output power.

Radiated measurements are performed by rotating the EUT in three different orthogonal test planes to find the maximum emission. (Y Plane)

The EUT is a folding phone, pretest the open status and closed status, only the worst status perform final test and record in the report. For the accessories, pretest standalone mode / Earphone mode / Adapter mode / Wireless charging mode, only the worst status perform final test and record in the report.

Test Cases	Band	Bandwidth (MHz)	Modulation	RB #	Test Channel
		eg. 5M, 10M, 15M, 20M	eg. PI/2 BPSK, QPSK, 16QAM, 64QAM, 256QAM	1RB, Partial RB, Full RB	L/M/H
Max. Output Power	5G n77	10M, 15M, 20M, 25M, 30M, 40M, 50M, 60M, 70M, 80M, 90M, 100M	All Modulations	1RB, Full RB	L, M, H
	5G n78	10M, 15M, 20M, 25M, 30M, 40M, 50M, 60M, 70M, 80M, 90M, 100M	All Modulations	1RB, Full RB	L, M, H
Peak-to-Average Ratio	5G n77	20M	PI/2 BPSK, QPSK	Full RB	M
E.I.R.P	5G n77	10M, 15M, 20M, 25M, 30M, 40M, 50M, 60M, 70M, 80M, 90M, 100M	All Modulations	1RB, Full RB	L, M, H
	5G n78	10M, 15M, 20M, 25M, 30M, 40M, 50M, 60M, 70M, 80M, 90M, 100M	All Modulations	1RB, Full RB	L, M, H
26dB and 99% Bandwidth	5G n77	10M, 15M, 20M, 25M, 30M, 40M, 50M, 60M, 70M, 80M, 90M, 100M	QPSK, 16QAM, 64QAM, 256QAM	Full RB	M
Conducted Band Edge	5G n77	10M, 50M, 100M	PI/2 BPSK, QPSK	1RB, Full RB	L, H
Conducted Spurious Emission	5G n77	10M, 50M, 100M	PI/2 BPSK, QPSK	1RB	L, M, H
Frequency Stability	5G n77	20M	QPSK	Full RB	M
Radiated Spurious Emission	5G n77	Worst case from maximum power			M

Note:

1. The device is investigated from 30MHz to 10 times of fundamental signal for radiated spurious emission test under different RB size/offset and modulations in exploratory test. Subsequently, only the worst case emissions are reported.
2. Frequency Stability: Normal Voltage = 3.86V; Low Voltage =3.50V; High Voltage =4.53V.

2.2 Connection Diagram of Test System

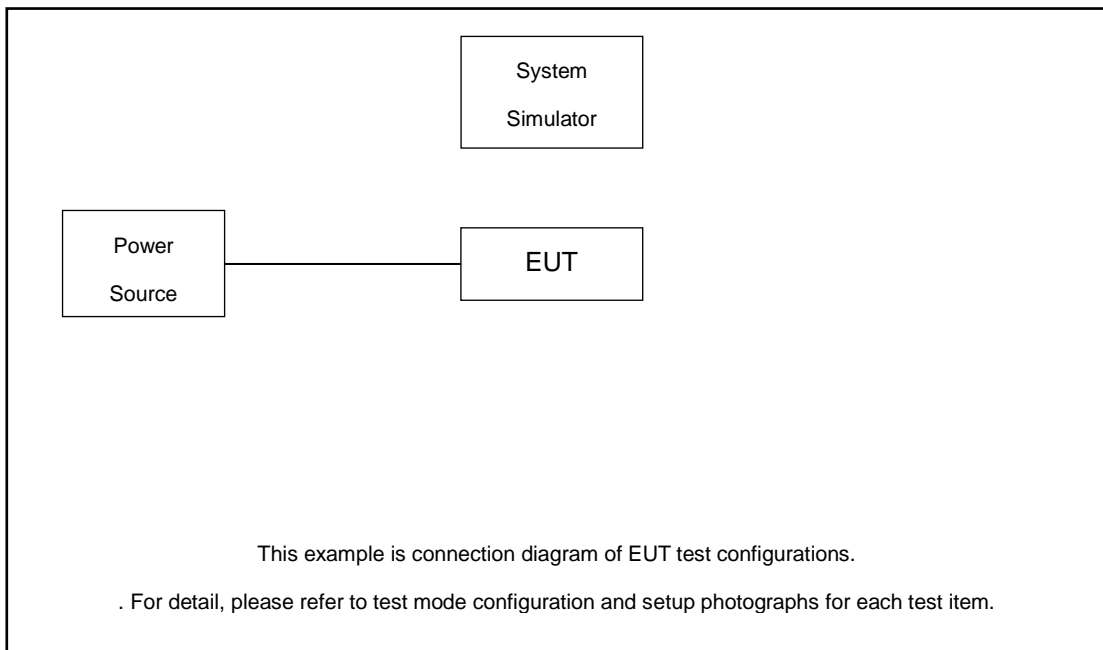

2.3 Support Unit used in test configuration and system

Item	Equipment	Trade Name	Model No.	FCC ID	Data Cable	Power Cord
1.	Power Supply	GWINSTEK	PSS-2002	N/A	N/A	Unshielded, 1.8 m
2.	LTE Base Station	Anritsu	MT8820C	N/A	N/A	Unshielded, 1.8 m
3.	NR Base Station	Anritsu	MT8000A	N/A	N/A	Unshielded, 1.8 m

2.4 Measurement Results Explanation Example

For all conducted test items:

The offset level is set in the spectrum analyzer to compensate the RF cable loss and attenuator factor between EUT conducted output port and spectrum analyzer. With the offset compensation, the spectrum analyzer reading level is exactly the EUT RF output level.

The spectrum analyzer offset is derived from RF cable loss and attenuator factor.

Offset = RF cable loss + attenuator factor.

Following shows an offset computation example with cable loss 6.5 dB and 20dB attenuator.

$$\begin{aligned}
 \text{Offset}(dB) &= \text{RF cable loss}(dB) + \text{attenuator factor}(dB). \\
 &= 6.5 + 20 = 26.5 \text{ (dB)}
 \end{aligned}$$



2.5 Frequency List of Low/Middle/High Channels

5G n77/n78 Channel and Frequency List for SCS 30kHz				
BW [MHz]	Channel/Frequency(MHz)	Lowest	Middle	Highest
100	Channel	-	633334	-
	Frequency	-	3500.01	-
90	Channel	633000	633334	633666
	Frequency	3495	3500.01	3504.99
80	Channel	632668	633334	634000
	Frequency	3490.02	3500.01	3510
70	Channel	632334	633334	634332
	Frequency	3485.01	3500.01	3514.98
60	Channel	632000	633334	634666
	Frequency	3480	3500.01	3519.99
50	Channel	631668	633334	635000
	Frequency	3475.02	3500.01	3525
40	Channel	631334	633334	635332
	Frequency	3470.01	3500.01	3529.98
30	Channel	631000	633334	635666
	Frequency	3465	3500.01	3534.99
25	Channel	630834	633334	635832
	Frequency	3462.51	3500.01	3537.48
20	Channel	630668	633334	636000
	Frequency	3460.02	3500.01	3540
15	Channel	630500	633334	636166
	Frequency	3457.5	3500.01	3542.49
10	Channel	630334	633334	636332
	Frequency	3455.01	3500.01	3544.98

3 Conducted Test Items

3.1 Measuring Instruments

See list of measuring instruments of this test report.

3.2 Test Setup

3.2.1 Conducted Output Power

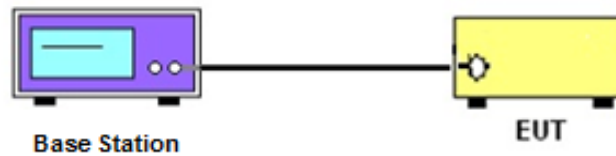

3.2.2 Peak-to-Average Ratio, Occupied / 26dB Bandwidth, Band-Edge and Conducted Spurious Emission

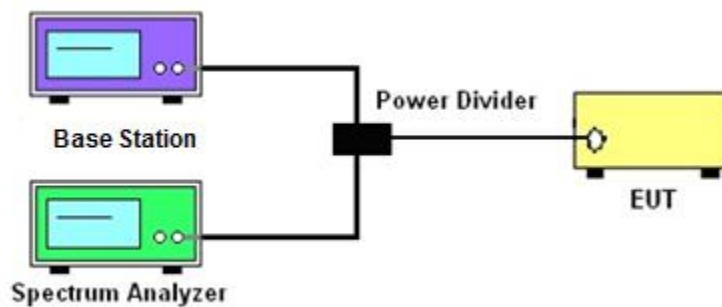

3.2.3 Frequency Stability

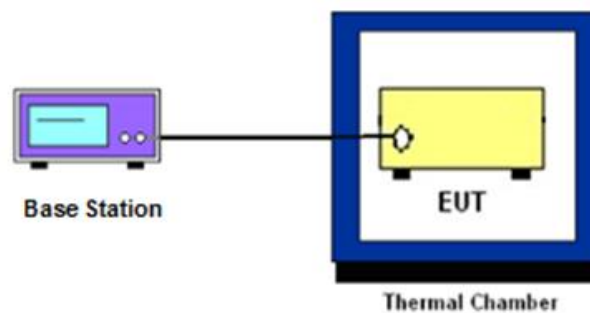

3.3 Test Result of Conducted Test

Please refer to Appendix A.



3.4 Conducted Output Power Measurement

3.4.1 Description of the Conducted Output Power Measurement

A base station simulator was used to establish communication with the EUT. Its parameters were set to transmit the maximum power on the EUT. The measured power in the radio frequency on the transmitter output terminals shall be reported.

3.4.2 Test Procedures

1. The testing follows ANSI C63.26 Section 5.2
2. The transmitter output port was connected to the system simulator.
3. Set EUT at maximum power through the system simulator.
4. Select lowest, middle, and highest channels for each band and different modulation.
5. Measure and record the power level from the system simulator.

3.5 Peak-to-Average Ratio

3.5.1 Description of the PAR Measurement

Power Complementary Cumulative Distribution Function (CCDF) curves provide a means for characterizing the power peaks of a digitally modulated signal on a statistical basis. A CCDF curve depicts the probability of the peak signal amplitude exceeding the average power level. Most contemporary measurement instrumentation include the capability to produce CCDF curves for an input signal provided that the instrument's resolution bandwidth can be set wide enough to accommodate the entire input signal bandwidth. In measuring transmissions in this band using an average power technique, the peak-to-average ratio (PAR) of the transmission may not exceed 13 dB.

3.5.2 Test Procedures

1. The testing follows ANSI C63.26 Section 5.2.3.4 (CCDF).
2. The EUT was connected to spectrum and system simulator via a power divider.
3. Set the CCDF (Complementary Cumulative Distribution Function) option in spectrum analyzer.
4. The highest RF powers were measured and recorded the maximum PAPR level associated with a probability of 0.1 %.
5. Record the deviation as Peak to Average Ratio.

3.6 EIRP

3.6.1 Description of EIRP Limit

§ 27.50 (k)(3)

Mobile devices are limited to 1Watt (30 dBm) EIRP. Mobile devices operating in these bands must employ a means for limiting power to the minimum necessary for successful communications

3.6.2 Test Procedures

1. According to KDB 412172 D01 Power Approach,
2. $EIRP = P_T + G_T - L_C$, $ERP = EIRP - 2.15$, where
 P_T = transmitter output power in dBm
 G_T = gain of the transmitting antenna in dBi
 L_C = signal attenuation in the connecting cable between the transmitter and antenna in dB

3.7 Occupied Bandwidth

3.7.1 Description of Occupied Bandwidth Measurement

The occupied bandwidth is the width of a frequency band such that, below the lower and above the upper frequency limits, the mean powers emitted are each equal to a specified percentage 0.5% of the total mean transmitted power.

The 26 dB emission bandwidth is defined as the frequency range between two points, one above and one below the carrier frequency, at which the spectral density of the emission is attenuated 26 dB below the maximum in-band spectral density of the modulated signal. Spectral density (power per unit bandwidth) is to be measured with a detector of resolution bandwidth equal to approximately 1.0% of the emission bandwidth.

3.7.2 Test Procedures

1. The testing follows ANSI C63.26 Section 5.4
2. The EUT was connected to spectrum analyzer and system simulator via a power divider.
3. The spectrum analyzer center frequency is set to the nominal EUT channel center frequency. The span range for the spectrum analyzer shall be between two and five times the anticipated OBW.
4. The nominal resolution bandwidth (RBW) shall be in the range of 1 to 5 % of the anticipated OBW, and the VBW shall be at least 3 times the RBW.
5. Set the detection mode to peak, and the trace mode to max hold.
6. Determine the reference value: Set the EUT to transmit a modulated signal. Allow the trace to stabilize. Set the spectrum analyzer marker to the highest level of the displayed trace.
(this is the reference value)
7. Determine the “-26 dB down amplitude” as equal to (Reference Value – X).
8. Place two markers, one at the lowest and the other at the highest frequency of the envelope of the spectral display such that each marker is at or slightly below the “-X dB down amplitude” determined in step 6. If a marker is below this “-X dB down amplitude” value it shall be placed as close as possible to this value. The OBW is the positive frequency difference between the two markers.
9. Use the 99 % power bandwidth function of the spectrum analyzer and report the measured bandwidth.

3.8 Conducted Band Edge Measurement

3.8.1 Description of Conducted Band Edge Measurement

§ 27.53 (n)(2)

For mobile operations in the 3450-3550 MHz band, the conducted power of any emission outside the licensee's authorized bandwidth shall not exceed -13 dBm/MHz.

Compliance with this paragraph is based on the use of measurement instrumentation employing a resolution bandwidth of 1 megahertz or greater. However, in the 1 megahertz bands immediately outside and adjacent to the licensee's frequency block, a resolution bandwidth of at least one percent of the emission bandwidth of the fundamental emission of the transmitter may be employed, but limited to a maximum of 200 kHz. In the bands between 1 and 5 MHz removed from the licensee's frequency block, the minimum resolution bandwidth for the measurement shall be 500 kHz.

3.8.2 Test Procedures

1. The testing follows ANSI C63.26 section 5.7
2. The EUT was connected to spectrum analyzer and system simulator via a power divider.
3. The band edges of low and high channels for the highest RF powers were measured.
4. Set RBW \geq 1% EBW but limited to a maximum of 200 kHz in the 1MHz band immediately outside and adjacent to the band edge.
5. Beyond the 1 MHz and 5 MHz removed from the band edge, set RBW \geq 500KHz.
6. Beyond the 5 MHz removed from the band edge, set RBW = 1MHz.
7. Set spectrum analyzer with RMS detector.
8. The RF fundamental frequency should be excluded against the limit line in the operating frequency band.
9. Checked that all the results comply with the emission limit line.

3.9 Conducted Spurious Emission Measurement

3.9.1 Description of Conducted Spurious Emission Measurement

The power of any emission outside of the authorized operating frequency ranges shall not exceed -13 dBm/MHz.

It is measured by means of a calibrated spectrum analyzer and scanned from 30MHz up to a frequency including its 10th harmonic.

3.9.2 Test Procedures

1. The testing follows ANSI C63.26 section 5.7
2. The EUT was connected to spectrum analyzer and system simulator via a power divider.
3. The RF output of EUT was connected to the spectrum analyzer by RF cable and attenuator. The path loss was compensated to the results for each measurement.
4. The middle channel for the highest RF power within the transmitting frequency was measured.
5. The conducted spurious emission for the whole frequency range was taken.
6. Make the measurement with the spectrum analyzer's RBW = 1MHz, VBW = 3MHz.
7. Set spectrum analyzer with RMS detector.
8. Taking the record of maximum spurious emission.
9. The RF fundamental frequency should be excluded against the limit line in the operating frequency band.
10. Checked that all the results comply with the emission limit line.

3.10 Frequency Stability Measurement

3.10.1 Description of Frequency Stability Measurement

The frequency stability shall be measured by variation of ambient temperature and variation of primary supply voltage to ensure that the fundamental emission stays within the authorized frequency block.

3.10.2 Test Procedures for Temperature Variation

1. The testing follows ANSI C63.26 section 5.6.4
2. The EUT was set up in the thermal chamber and connected with the system simulator.
3. With power OFF, the temperature was decreased to -30°C and the EUT was stabilized before testing. Power was applied and the maximum change in frequency was recorded within one minute.
4. With power OFF, the temperature was raised in 10°C step up to 50°C . The EUT was stabilized at each step for at least half an hour. Power was applied and the maximum frequency change was recorded within one minute.

3.10.3 Test Procedures for Voltage Variation

1. The testing follows ANSI C63.26 section 5.6.5.
2. The EUT was placed in a temperature chamber at $20\pm 5^{\circ}\text{C}$ and connected with the system simulator.
3. The power supply voltage to the EUT was varied from 85% to 115% of the nominal value for other than hand carried battery equipment.
4. For hand carried, battery powered equipment, reduce the primary ac or dc supply voltage to the battery operating end point, which shall be specified by the manufacturer.
5. The variation in frequency was measured for the worst case.

4 Radiated Test Items

4.1 Measuring Instruments

See list of measuring instruments of this test report.

4.2 Test Setup

4.2.1 For radiated test below 30MHz

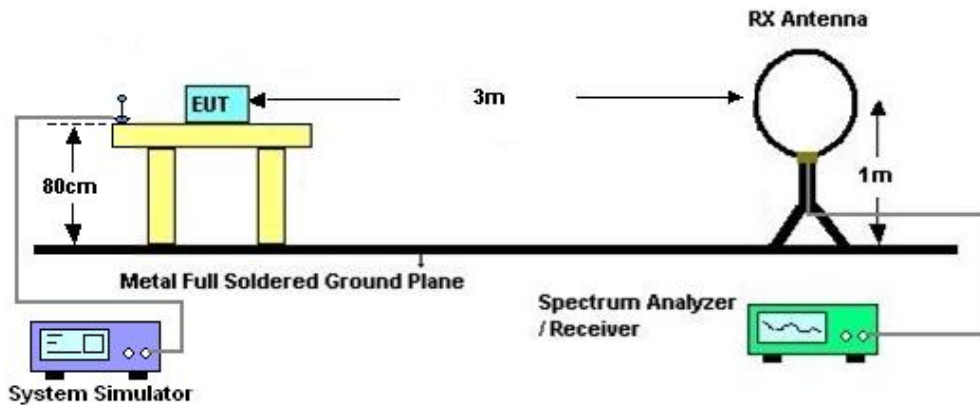

4.2.2 For radiated test from 30MHz to 1GHz

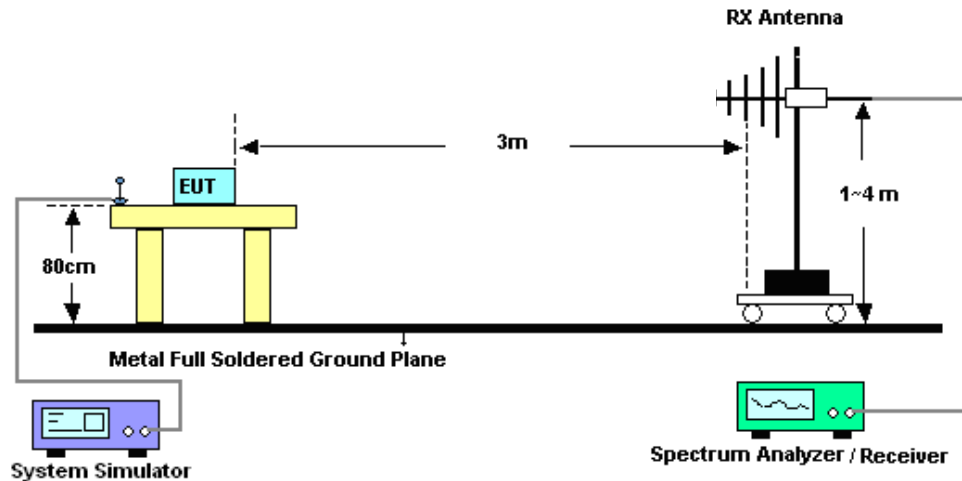

4.2.3 For radiated test above 1GHz

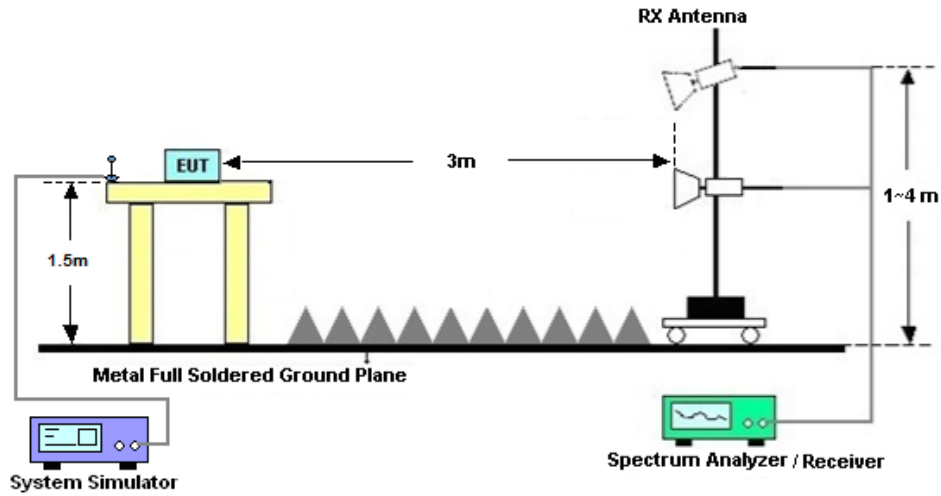

4.3 Test Result of Radiated Test

The low frequency, which started from 9 kHz to 30MHz, was pre-scanned and the result which was 20dB lower than the limit line was not reported.

Please refer to Appendix B.

4.4 Radiated Spurious Emission Measurement

4.4.1 Description of Radiated Spurious Emission

The radiated spurious emission was measured by substitution method according to ANSI C63.26. The power of any emission outside of the authorized operating frequency ranges shall not exceed -13 dBm/MHz.

The spectrum is scanned from 30 MHz up to a frequency including its 10th harmonic.

4.4.2 Test Procedures

1. The testing follows ANSI C63.26 Section 5.5
2. The EUT was placed on a turntable with 0.8 meter height for frequency below 1GHz and 1.5 meter height for frequency above 1GHz respectively above ground.
3. The EUT was set 3 meters from the receiving antenna mounted on the antenna tower.
4. The table was rotated 360 degrees to determine the position of the highest spurious emission.
5. The height of the receiving antenna is varied between 1m to 4m to search the maximum spurious emission for both horizontal and vertical polarizations.
6. During the measurement, the system simulator parameters were set to force the EUT transmitting at maximum output power.
7. Make the measurement with the spectrum analyzer's RBW = 1MHz, VBW = 3MHz, taking the record of maximum spurious emission.
8. A horn antenna was substituted in place of the EUT and was driven by a signal generator.
9. Tune the output power of signal generator to the same emission level with EUT maximum spurious emission.
$$\text{EIRP (dBm)} = \text{S.G. Power} - \text{Tx Cable Loss} + \text{Tx Antenna Gain}$$
$$\text{ERP (dBm)} = \text{EIRP} - 2.15$$
10. The RF fundamental frequency should be excluded against the limit line in the operating frequency band.



5 List of Measuring Equipment

Instrument	Manufacturer	Model No.	Serial No.	Characteristics	Calibration Date	Test Date	Due Date	Remark
Spectrum Analyzer	R&S	FSV40	101040	10Hz~40GHz	Oct. 10, 2024	Dec. 11, 2024~ Dec. 12, 2024	Oct. 09, 2025	Conducted (TH01-KS)
Power divider	STI	STI08-0055	-	0.5~40GHz	NCR	Dec. 11, 2024~ Dec. 12, 2024	NCR	Conducted (TH01-KS)
Temperature & humidity chamber	Hongzhan	LP-150U	H2014011440	-40~+150°C 20%~95%RH	Jul. 04, 2024	Dec. 11, 2024~ Dec. 12, 2024	Jul. 03, 2025	Conducted (TH01-KS)
EXA Spectrum Analyzer	Keysight	N9010A	MY55150244	10Hz~44GHz	Apr. 18, 2024	Dec. 31, 2024	Apr. 13, 2025	Radiation (03CH03-KS)
Loop Antenna	R&S	HFH2-Z2E	101125	9kHz~30MHz	Sep. 08, 2024	Dec. 31, 2024	Sep. 07, 2025	Radiation (03CH03-KS)
Bilog Antenna	TeseQ	CBL6112D	23182	30MHz~1GHz	Dec. 05, 2024	Dec. 31, 2024	Dec. 04, 2025	Radiation (03CH03-KS)
Double Ridge Horn Antenna	ETS-Lindgren	3117	00251982	1GHz~18GHz	Aug. 16, 2024	Dec. 31, 2024	Aug. 15, 2025	Radiation (03CH03-KS)
SHF-EHF Horn	com-power	AH-840	101093	18GHz~40GHz	Jan. 06, 2024	Dec. 31, 2024	Jan. 05, 2025	Radiation (03CH03-KS)
Amplifier	SONOMA	310N	413740	30MHz ~1000MHz	Jan. 03, 2024	Dec. 31, 2024	Jan. 02, 2025	Radiation (03CH03-KS)
Amplifier	EM	EM18G40G A	060851	18~40GHz	Jan. 03, 2024	Dec. 31, 2024	Jan. 02, 2025	Radiation (03CH03-KS)
high gain Amplifier	MITEQ	AMF-7D-00 101800-30-1 0P	2082394	1Ghz-18Ghz	Jan. 03, 2024	Dec. 31, 2024	Jan. 02, 2025	Radiation (03CH03-KS)
Amplifier	Keysight	83017A	MY53270319	1GHz~26.5GHz	Oct. 09, 2024	Dec. 31, 2024	Oct. 08, 2025	Radiation (03CH03-KS)
AC Power Source	Chroma	61601	F104090004	N/A	NCR	Dec. 31, 2024	NCR	Radiation (03CH03-KS)
Turn Table	ChamPro	EM 1000-T	060762-T	0~360 degree	NCR	Dec. 31, 2024	NCR	Radiation (03CH03-KS)
Antenna Mast	ChamPro	EM 1000-A	060762-A	1 m~4 m	NCR	Dec. 31, 2024	NCR	Radiation (03CH03-KS)

NCR: No Calibration Required



6 Measurement Uncertainty

The measurement uncertainties shown below were calculated in accordance with the requirements of ANSI 63.26-2015. All the measurement uncertainty value were shown with a coverage K=2 to indicate 95% level of confidence. The measurement data show herein meets or exceeds the CISPR measurement uncertainty values specified in CISPR 16-4-2 and can be compared directly to specified limit to determine compliance.

Uncertainty of Conducted Measurement

Test Item	Uncertainty
Conducted Spurious Emission & Bandedge	±2.22 dB
Occupied Channel Bandwidth	±0.1%
Conducted Power	±0.50 dB
Peak to Average Ratio	±0.50 dB
Frequency Stability	±0.04 ppm

Uncertainty of Radiated Emission Measurement (30 MHz ~ 1000 MHz)

Measuring Uncertainty for a Level of Confidence of 95% (U = 2Uc(y))	2.84dB
---	--------

Uncertainty of Radiated Emission Measurement (1 GHz ~ 18 GHz)

Measuring Uncertainty for a Level of Confidence of 95% (U = 2Uc(y))	2.84dB
---	--------

Uncertainty of Radiated Emission Measurement (18 GHz ~ 40 GHz)

Measuring Uncertainty for a Level of Confidence of 95% (U = 2Uc(y))	2.83dB
---	--------

----- THE END -----



Appendix A. Test Results of Conducted Test

Test Engineer :	Smile Wang	Temperature :	22~23°C
		Relative Humidity :	40~42%



Software Version: 23.06.1602

FR1 N77(Ant.4)

Transmitter Conducted Output Power and EIRP, (GT - LC)= -0.9dB

NR Band	SCS	BandWidth	Arfcn	Freq (MHz)	Modulation	RB	Conducted Power(dBm)	EIRP (dBm)	EIRP (W)
77	30	10	630334	3455.01	DFT-s-OFDM PI/2 BPSK	1@1	26.48	25.58	0.3614
77	30	10	630334	3455.01	DFT-s-OFDM QPSK	1@1	26.55	25.65	0.3673
77	30	10	630334	3455.01	DFT-s-OFDM 16 QAM	1@1	24.61	23.71	0.2350
77	30	10	633334	3500.01	DFT-s-OFDM PI/2 BPSK	1@1	26.26	25.36	0.3436
77	30	10	633334	3500.01	DFT-s-OFDM QPSK	1@1	26.33	25.43	0.3491
77	30	10	633334	3500.01	DFT-s-OFDM 16 QAM	1@1	24.57	23.67	0.2328
77	30	10	636332	3544.98	DFT-s-OFDM PI/2 BPSK	1@1	26.43	25.53	0.3573
77	30	10	636332	3544.98	DFT-s-OFDM QPSK	1@1	26.58	25.68	0.3698
77	30	10	636332	3544.98	DFT-s-OFDM 16 QAM	1@1	24.77	23.87	0.2438
77	30	15	630500	3457.5	DFT-s-OFDM PI/2 BPSK	1@1	26.61	25.71	0.3724
77	30	15	630500	3457.5	DFT-s-OFDM QPSK	1@1	26.43	25.53	0.3573
77	30	15	630500	3457.5	DFT-s-OFDM 16 QAM	1@1	24.76	23.86	0.2432
77	30	15	633334	3500.01	DFT-s-OFDM PI/2 BPSK	1@1	26.39	25.49	0.3540
77	30	15	633334	3500.01	DFT-s-OFDM QPSK	1@1	26.51	25.61	0.3639
77	30	15	633334	3500.01	DFT-s-OFDM 16 QAM	1@1	24.53	23.63	0.2307
77	30	15	636166	3542.49	DFT-s-OFDM PI/2 BPSK	1@1	26.65	25.75	0.3758
77	30	15	636166	3542.49	DFT-s-OFDM QPSK	1@1	26.61	25.71	0.3724
77	30	15	636166	3542.49	DFT-s-OFDM 16 QAM	1@1	24.84	23.94	0.2477
77	30	20	630668	3460.02	DFT-s-OFDM PI/2 BPSK	1@1	26.53	25.63	0.3656
77	30	20	630668	3460.02	DFT-s-OFDM QPSK	1@1	26.26	25.36	0.3436
77	30	20	630668	3460.02	DFT-s-OFDM 16 QAM	1@1	24.84	23.94	0.2477
77	30	20	633334	3500.01	DFT-s-OFDM PI/2 BPSK	1@1	26.47	25.57	0.3606
77	30	20	633334	3500.01	DFT-s-OFDM QPSK	1@1	26.36	25.46	0.3516
77	30	20	633334	3500.01	DFT-s-OFDM 16 QAM	1@1	24.77	23.87	0.2438
77	30	20	636000	3540	DFT-s-OFDM PI/2 BPSK	1@1	26.55	25.65	0.3673
77	30	20	636000	3540	DFT-s-OFDM QPSK	1@1	26.53	25.63	0.3656
77	30	20	636000	3540	DFT-s-OFDM 16 QAM	1@1	24.84	23.94	0.2477
77	30	25	630834	3462.51	DFT-s-OFDM PI/2 BPSK	1@1	26.91	26.01	0.3990
77	30	25	630834	3462.51	DFT-s-OFDM QPSK	1@1	26.73	25.83	0.3828
77	30	25	630834	3462.51	DFT-s-OFDM 16 QAM	1@1	24.93	24.03	0.2529
77	30	25	633334	3500.01	DFT-s-OFDM PI/2 BPSK	1@1	26.4	25.5	0.3548
77	30	25	633334	3500.01	DFT-s-OFDM QPSK	1@1	26.41	25.51	0.3556
77	30	25	633334	3500.01	DFT-s-OFDM 16 QAM	1@1	24.8	23.9	0.2455
77	30	25	635832	3537.48	DFT-s-OFDM PI/2 BPSK	1@1	26.58	25.68	0.3698
77	30	25	635832	3537.48	DFT-s-OFDM QPSK	1@1	26.62	25.72	0.3733



77	30	25	635832	3537.48	DFT-s-OFDM 16 QAM	1@1	24.89	23.99	0.2506
77	30	30	631000	3465	DFT-s-OFDM PI/2 BPSK	1@1	26.74	25.84	0.3837
77	30	30	631000	3465	DFT-s-OFDM QPSK	1@1	26.62	25.72	0.3733
77	30	30	631000	3465	DFT-s-OFDM 16 QAM	1@1	24.94	24.04	0.2535
77	30	30	633334	3500.01	DFT-s-OFDM PI/2 BPSK	1@1	26.47	25.57	0.3606
77	30	30	633334	3500.01	DFT-s-OFDM QPSK	1@1	26.37	25.47	0.3524
77	30	30	633334	3500.01	DFT-s-OFDM 16 QAM	1@1	24.89	23.99	0.2506
77	30	30	635666	3534.99	DFT-s-OFDM PI/2 BPSK	1@1	26.57	25.67	0.3690
77	30	30	635666	3534.99	DFT-s-OFDM QPSK	1@1	26.49	25.59	0.3622
77	30	30	635666	3534.99	DFT-s-OFDM 16 QAM	1@1	24.75	23.85	0.2427
77	30	40	631334	3470.01	DFT-s-OFDM PI/2 BPSK	1@1	26.59	25.69	0.3707
77	30	40	631334	3470.01	DFT-s-OFDM QPSK	1@1	26.47	25.57	0.3606
77	30	40	631334	3470.01	DFT-s-OFDM 16 QAM	1@1	24.75	23.85	0.2427
77	30	40	633334	3500.01	DFT-s-OFDM PI/2 BPSK	1@1	26.46	25.56	0.3597
77	30	40	633334	3500.01	DFT-s-OFDM QPSK	1@1	26.43	25.53	0.3573
77	30	40	633334	3500.01	DFT-s-OFDM 16 QAM	1@1	24.78	23.88	0.2443
77	30	40	635332	3529.98	DFT-s-OFDM PI/2 BPSK	1@1	26.57	25.67	0.3690
77	30	40	635332	3529.98	DFT-s-OFDM QPSK	1@1	26.38	25.48	0.3532
77	30	40	635332	3529.98	DFT-s-OFDM 16 QAM	1@1	24.72	23.82	0.2410
77	30	50	631668	3475.02	DFT-s-OFDM PI/2 BPSK	1@1	26.61	25.71	0.3724
77	30	50	631668	3475.02	DFT-s-OFDM QPSK	1@1	26.67	25.77	0.3776
77	30	50	631668	3475.02	DFT-s-OFDM 16 QAM	1@1	25.06	24.16	0.2606
77	30	50	633334	3500.01	DFT-s-OFDM PI/2 BPSK	1@1	26.52	25.62	0.3648
77	30	50	633334	3500.01	DFT-s-OFDM QPSK	1@1	26.66	25.76	0.3767
77	30	50	633334	3500.01	DFT-s-OFDM 16 QAM	1@1	25.02	24.12	0.2582
77	30	50	635000	3525	DFT-s-OFDM PI/2 BPSK	1@1	26.76	25.86	0.3855
77	30	50	635000	3525	DFT-s-OFDM QPSK	1@1	26.62	25.72	0.3733
77	30	50	635000	3525	DFT-s-OFDM 16 QAM	1@1	24.8	23.9	0.2455
77	30	60	632000	3480	DFT-s-OFDM PI/2 BPSK	1@1	26.68	25.78	0.3784
77	30	60	632000	3480	DFT-s-OFDM QPSK	1@1	26.62	25.72	0.3733
77	30	60	632000	3480	DFT-s-OFDM 16 QAM	1@1	24.78	23.88	0.2443
77	30	60	633334	3500.01	DFT-s-OFDM PI/2 BPSK	1@1	26.66	25.76	0.3767
77	30	60	633334	3500.01	DFT-s-OFDM QPSK	1@1	26.65	25.75	0.3758
77	30	60	633334	3500.01	DFT-s-OFDM 16 QAM	1@1	24.74	23.84	0.2421
77	30	60	634666	3519.99	DFT-s-OFDM PI/2 BPSK	1@1	26.42	25.52	0.3565
77	30	60	634666	3519.99	DFT-s-OFDM QPSK	1@1	26.58	25.68	0.3698
77	30	60	634666	3519.99	DFT-s-OFDM 16 QAM	1@1	24.73	23.83	0.2415
77	30	70	632334	3485.01	DFT-s-OFDM PI/2 BPSK	1@1	26.76	25.86	0.3855
77	30	70	632334	3485.01	DFT-s-OFDM QPSK	1@1	26.69	25.79	0.3793
77	30	70	632334	3485.01	DFT-s-OFDM 16 QAM	1@1	25.13	24.23	0.2649
77	30	70	633334	3500.01	DFT-s-OFDM PI/2 BPSK	1@1	26.46	25.56	0.3597
77	30	70	633334	3500.01	DFT-s-OFDM QPSK	1@1	26.76	25.86	0.3855



77	30	70	633334	3500.01	DFT-s-OFDM 16 QAM	1@1	24.93	24.03	0.2529
77	30	70	634332	3514.98	DFT-s-OFDM PI/2 BPSK	1@1	26.52	25.62	0.3648
77	30	70	634332	3514.98	DFT-s-OFDM QPSK	1@1	26.49	25.59	0.3622
77	30	70	634332	3514.98	DFT-s-OFDM 16 QAM	1@1	25	24.1	0.2570
77	30	80	632668	3490.02	DFT-s-OFDM PI/2 BPSK	1@1	26.72	25.82	0.3819
77	30	80	632668	3490.02	DFT-s-OFDM QPSK	1@1	26.82	25.92	0.3908
77	30	80	632668	3490.02	DFT-s-OFDM 16 QAM	1@1	24.95	24.05	0.2541
77	30	80	633334	3500.01	DFT-s-OFDM PI/2 BPSK	1@1	26.74	25.84	0.3837
77	30	80	633334	3500.01	DFT-s-OFDM QPSK	1@1	26.74	25.84	0.3837
77	30	80	633334	3500.01	DFT-s-OFDM 16 QAM	1@1	25.03	24.13	0.2588
77	30	80	634000	3510	DFT-s-OFDM PI/2 BPSK	1@1	26.83	25.93	0.3917
77	30	80	634000	3510	DFT-s-OFDM QPSK	1@1	26.82	25.92	0.3908
77	30	80	634000	3510	DFT-s-OFDM 16 QAM	1@1	24.86	23.96	0.2489
77	30	90	633000	3495	DFT-s-OFDM PI/2 BPSK	1@1	26.77	25.87	0.3864
77	30	90	633000	3495	DFT-s-OFDM QPSK	1@1	26.82	25.92	0.3908
77	30	90	633000	3495	DFT-s-OFDM 16 QAM	1@1	24.99	24.09	0.2564
77	30	90	633334	3500.01	DFT-s-OFDM PI/2 BPSK	1@1	26.81	25.91	0.3899
77	30	90	633334	3500.01	DFT-s-OFDM QPSK	1@1	26.75	25.85	0.3846
77	30	90	633334	3500.01	DFT-s-OFDM 16 QAM	1@1	24.9	24	0.2512
77	30	90	633666	3504.99	DFT-s-OFDM PI/2 BPSK	1@1	26.85	25.95	0.3936
77	30	90	633666	3504.99	DFT-s-OFDM QPSK	1@1	26.83	25.93	0.3917
77	30	90	633666	3504.99	DFT-s-OFDM 16 QAM	1@1	24.98	24.08	0.2559
77	30	100	633334	3500.01	DFT-s-OFDM PI/2 BPSK	135@67	26.35	25.45	0.3508
77	30	100	633334	3500.01	DFT-s-OFDM PI/2 BPSK	1@1	26.57	25.67	0.3690
77	30	100	633334	3500.01	DFT-s-OFDM PI/2 BPSK	1@271	26.42	25.52	0.3565
77	30	100	633334	3500.01	DFT-s-OFDM QPSK	135@67	26.36	25.46	0.3516
77	30	100	633334	3500.01	DFT-s-OFDM QPSK	1@1	26.63	25.73	0.3741
77	30	100	633334	3500.01	DFT-s-OFDM QPSK	1@271	26.64	25.74	0.3750
77	30	100	633334	3500.01	DFT-s-OFDM 16 QAM	135@67	24.85	23.95	0.2483
77	30	100	633334	3500.01	DFT-s-OFDM 16 QAM	1@1	24.85	23.95	0.2483
77	30	100	633334	3500.01	DFT-s-OFDM 16 QAM	1@271	24.67	23.77	0.2382
77	30	100	633334	3500.01	DFT-s-OFDM 64 QAM	135@67	23.34	22.44	0.1754
77	30	100	633334	3500.01	DFT-s-OFDM 64 QAM	1@1	23.27	22.37	0.1726
77	30	100	633334	3500.01	DFT-s-OFDM 64 QAM	1@271	22.85	21.95	0.1567
77	30	100	633334	3500.01	DFT-s-OFDM 256 QAM	135@67	21.28	20.38	0.1091
77	30	100	633334	3500.01	DFT-s-OFDM 256 QAM	1@1	21.36	20.46	0.1112
77	30	100	633334	3500.01	DFT-s-OFDM 256 QAM	1@271	21.09	20.19	0.1045
77	30	100	633334	3500.01	CP-OFDM QPSK	137@68	24.29	23.39	0.2183
77	30	100	633334	3500.01	CP-OFDM QPSK	1@1	24.42	23.52	0.2249
77	30	100	633334	3500.01	CP-OFDM QPSK	1@271	24.03	23.13	0.2056



Frequency Stability

NR Band	SCS (kHz)	Bandwidth (MHz)	Arfcn	Freq (MHz)	Modulation	RB	Deviation (ppm)	Verdict	Environment
77	30	20	633334	3500.01	DFT-s-OFDM QPSK	50@0	0.0027	PASS	NV
77	30	20	633334	3500.01	DFT-s-OFDM QPSK	50@0	0.0009	PASS	LV
77	30	20	633334	3500.01	DFT-s-OFDM QPSK	50@0	0.0034	PASS	HV
77	30	20	633334	3500.01	DFT-s-OFDM QPSK	50@0	-0.0009	PASS	-30°C
77	30	20	633334	3500.01	DFT-s-OFDM QPSK	50@0	0.0007	PASS	-20°C
77	30	20	633334	3500.01	DFT-s-OFDM QPSK	50@0	0.0035	PASS	-10°C
77	30	20	633334	3500.01	DFT-s-OFDM QPSK	50@0	0.0028	PASS	0°C
77	30	20	633334	3500.01	DFT-s-OFDM QPSK	50@0	0.0045	PASS	10°C
77	30	20	633334	3500.01	DFT-s-OFDM QPSK	50@0	0.0029	PASS	20°C
77	30	20	633334	3500.01	DFT-s-OFDM QPSK	50@0	0.0047	PASS	30°C
77	30	20	633334	3500.01	DFT-s-OFDM QPSK	50@0	0.0034	PASS	40°C
77	30	20	633334	3500.01	DFT-s-OFDM QPSK	50@0	0.0028	PASS	50°C



Peak to Average Ratio

NR Band	SCS (kHz)	Bandwidth (MHz)	Arfcn	Freq (MHz)	Modulation	RB	Result (dB)	Limit (dB)	Verdict
77	30	20	633334	3500.01	DFT-s-OFDM PI/2 BPSK	50@0	4.03	13	PASS
77	30	20	633334	3500.01	DFT-s-OFDM PI/2 BPSK	1@0	4.26	13	PASS
77	30	20	633334	3500.01	DFT-s-OFDM QPSK	50@0	4.81	13	PASS
77	30	20	633334	3500.01	DFT-s-OFDM QPSK	1@0	5.2	13	PASS



N77(20M)_DFT-s-OFDM_PI_2-BPSK_Outer_Full_Mid_CH



N77(20M)_DFT-s-OFDM_PI_2-BPSK_Edge_1RB_Left_Mid_CH



N77(20M)_DFT-s-OFDM_QPSK_Outer_Full_Mid_CH



N77(20M)_DFT-s-OFDM_QPSK_Edge_1RB_Left_Mid_CH

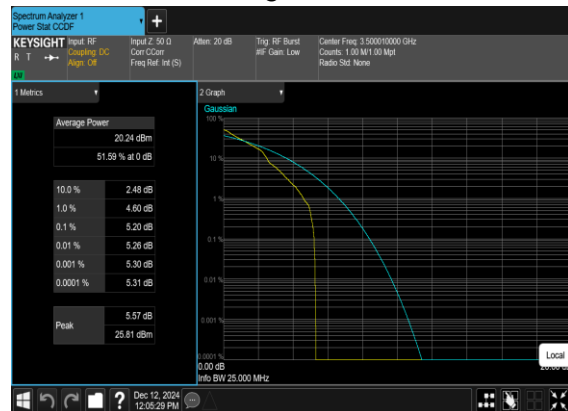



Occupied Bandwidth

NR Band	SCS (kHz)	Bandwidth (MHz)	Arfcn	Freq (MHz)	Modulation	RB	OBW (MHz)	26dB BW (MHz)
77	30	10	633334	3500.01	CP-OFDM QPSK	24@0	8.5701	9.711
77	30	10	633334	3500.01	CP-OFDM 16 QAM	24@0	8.5691	9.36
77	30	10	633334	3500.01	CP-OFDM 64 QAM	24@0	8.5737	9.275
77	30	10	633334	3500.01	CP-OFDM 256 QAM	24@0	8.5583	9.378
77	30	15	633334	3500.01	CP-OFDM QPSK	38@0	13.55	14.94
77	30	15	633334	3500.01	CP-OFDM 16 QAM	38@0	13.577	14.58
77	30	15	633334	3500.01	CP-OFDM 64 QAM	38@0	13.556	14.56
77	30	15	633334	3500.01	CP-OFDM 256 QAM	38@0	13.554	14.32
77	30	20	633334	3500.01	CP-OFDM QPSK	51@0	18.165	19.2
77	30	20	633334	3500.01	CP-OFDM 16 QAM	51@0	18.277	19.12
77	30	20	633334	3500.01	CP-OFDM 64 QAM	51@0	18.204	19.5
77	30	20	633334	3500.01	CP-OFDM 256 QAM	51@0	18.18	19.16
77	30	25	633334	3500.01	CP-OFDM QPSK	65@0	23.245	24.2
77	30	25	633334	3500.01	CP-OFDM 16 QAM	65@0	23.329	24.63
77	30	25	633334	3500.01	CP-OFDM 64 QAM	65@0	23.189	24.39
77	30	25	633334	3500.01	CP-OFDM 256 QAM	65@0	23.286	24.62
77	30	30	633334	3500.01	CP-OFDM QPSK	78@0	27.735	29.44
77	30	30	633334	3500.01	CP-OFDM 16 QAM	78@0	27.873	28.89
77	30	30	633334	3500.01	CP-OFDM 64 QAM	78@0	27.835	28.83
77	30	30	633334	3500.01	CP-OFDM 256 QAM	78@0	27.826	29.71
77	30	40	633334	3500.01	CP-OFDM QPSK	106@0	37.879	39.61
77	30	40	633334	3500.01	CP-OFDM 16 QAM	106@0	37.782	39.22
77	30	40	633334	3500.01	CP-OFDM 64 QAM	106@0	37.85	39.33



77	30	40	633334	3500.01	CP-OFDM 256 QAM	106@0	37.851	39.67
77	30	50	633334	3500.01	CP-OFDM QPSK	133@0	47.466	49.11
77	30	50	633334	3500.01	CP-OFDM 16 QAM	133@0	47.534	49.11
77	30	50	633334	3500.01	CP-OFDM 64 QAM	133@0	47.621	49.13
77	30	50	633334	3500.01	CP-OFDM 256 QAM	133@0	47.423	48.93
77	30	60	633334	3500.01	CP-OFDM QPSK	162@0	57.961	59.85
77	30	60	633334	3500.01	CP-OFDM 16 QAM	162@0	57.838	59.73
77	30	60	633334	3500.01	CP-OFDM 64 QAM	162@0	57.799	59.65
77	30	60	633334	3500.01	CP-OFDM 256 QAM	162@0	57.936	59.71
77	30	70	633334	3500.01	CP-OFDM QPSK	189@0	67.419	69.89
77	30	70	633334	3500.01	CP-OFDM 16 QAM	189@0	67.409	69.71
77	30	70	633334	3500.01	CP-OFDM 64 QAM	189@0	67.622	69.87
77	30	70	633334	3500.01	CP-OFDM 256 QAM	189@0	67.522	70.06
77	30	80	633334	3500.01	CP-OFDM QPSK	217@0	77.367	80.21
77	30	80	633334	3500.01	CP-OFDM 16 QAM	217@0	77.572	80.22
77	30	80	633334	3500.01	CP-OFDM 64 QAM	217@0	77.585	80.05
77	30	80	633334	3500.01	CP-OFDM 256 QAM	217@0	77.508	79.9
77	30	90	633334	3500.01	CP-OFDM QPSK	245@0	87.409	90.28
77	30	90	633334	3500.01	CP-OFDM 16 QAM	245@0	87.255	90.44
77	30	90	633334	3500.01	CP-OFDM 64 QAM	245@0	87.488	90.26
77	30	90	633334	3500.01	CP-OFDM 256 QAM	245@0	87.442	90.21
77	30	100	633334	3500.01	CP-OFDM QPSK	273@0	97.437	100.6
77	30	100	633334	3500.01	CP-OFDM 16 QAM	273@0	97.496	100.5
77	30	100	633334	3500.01	CP-OFDM 64 QAM	273@0	97.393	100.9
77	30	100	633334	3500.01	CP-OFDM 256 QAM	273@0	97.549	100.7



N77(10M)_CP-OFDM_QPSK_Outer_Full_Mid_CH

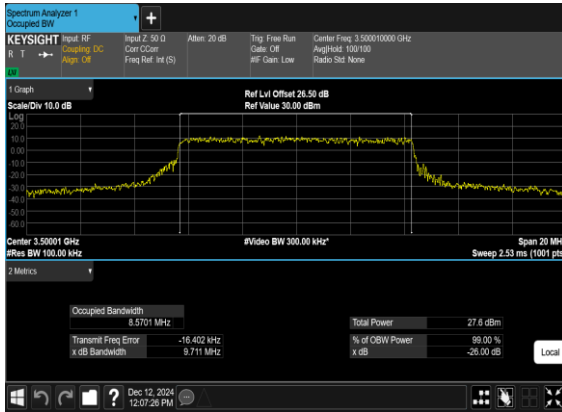

N77(10M)_CP-OFDM_16QAM_Outer_Full_Mid_CH

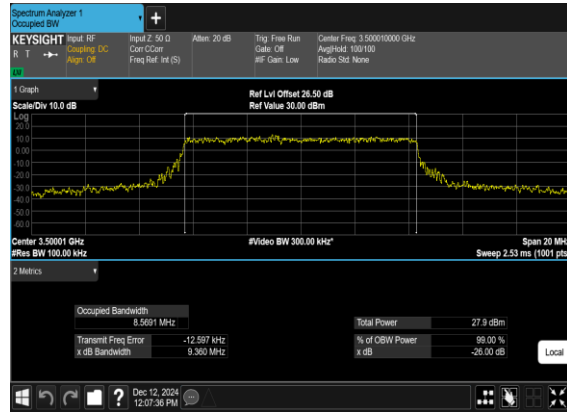

N77(10M)_CP-OFDM_64QAM_Outer_Full_Mid_CH

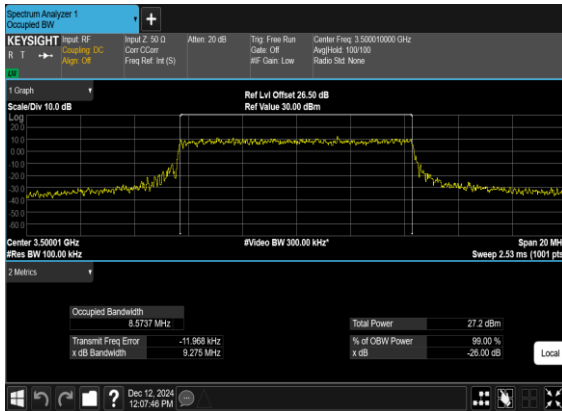

N77(10M)_CP-OFDM_256QAM_Outer_Full_Mid_CH

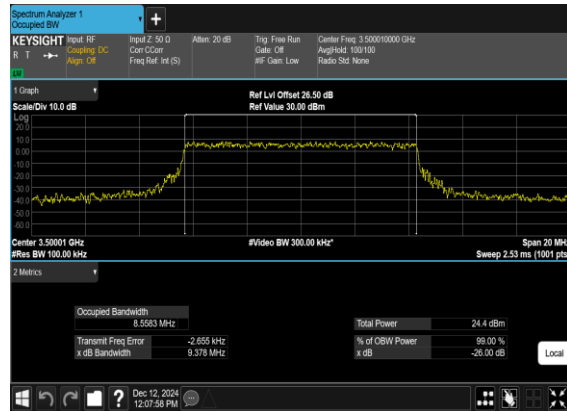



N77(15M)_CP-OFDM_QPSK_Outer_Full_Mid_CH

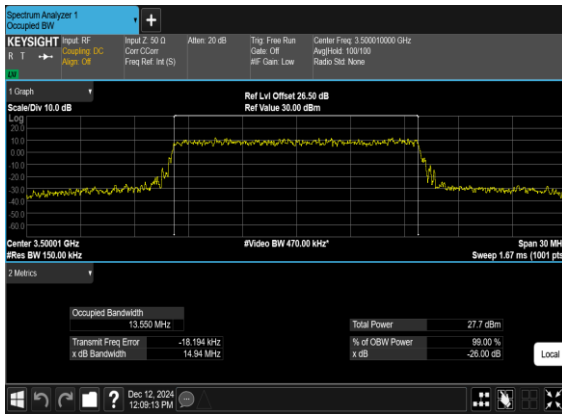

N77(15M)_CP-OFDM_16QAM_Outer_Full_Mid_CH

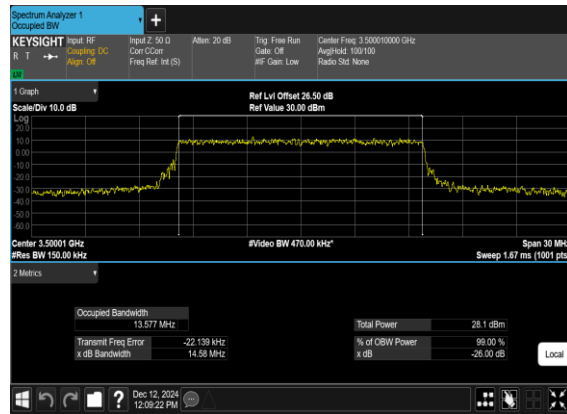

N77(15M)_CP-OFDM_64QAM_Outer_Full_Mid_CH

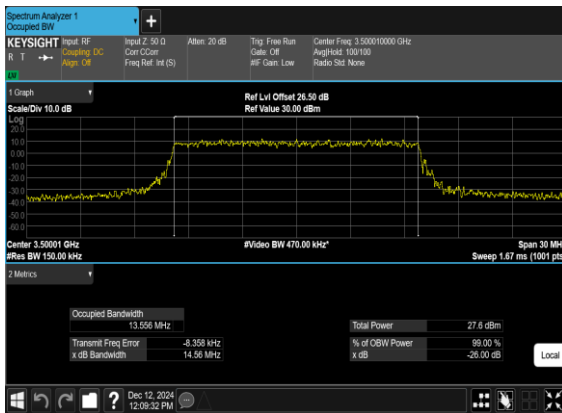

N77(15M)_CP-OFDM_256QAM_Outer_Full_Mid_CH

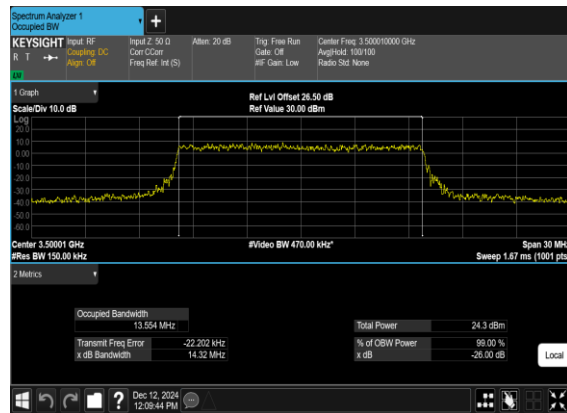



N77(20M)_CP-OFDM_QPSK_Outer_Full_Mid_CH

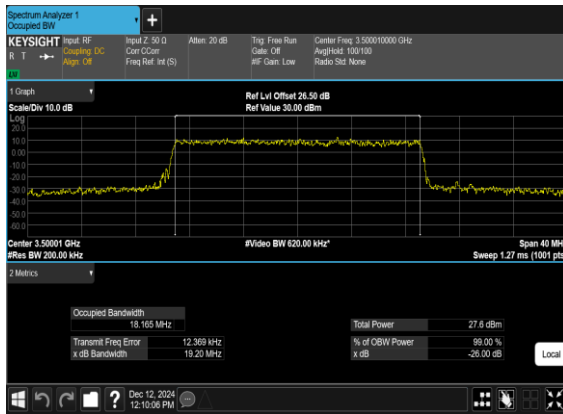

N77(20M)_CP-OFDM_16QAM_Outer_Full_Mid_CH

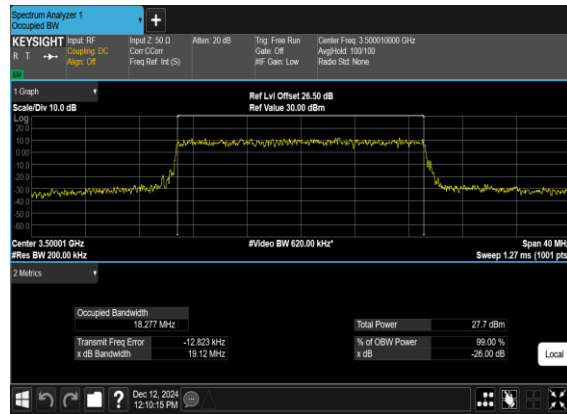

N77(20M)_CP-OFDM_64QAM_Outer_Full_Mid_CH

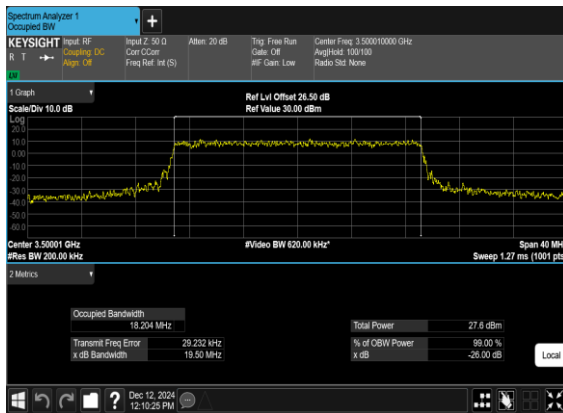

N77(20M)_CP-OFDM_256QAM_Outer_Full_Mid_CH

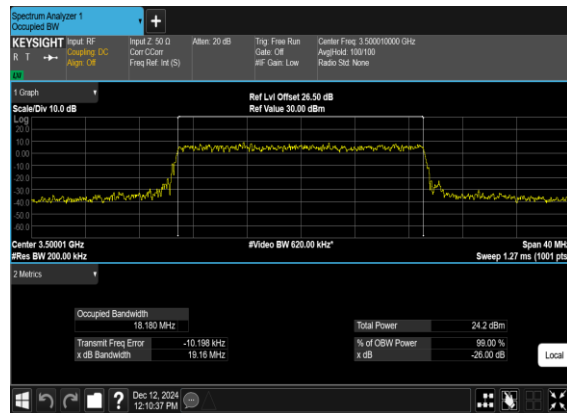



N77(25M)_CP-OFDM_QPSK_Outer_Full_Mid_CH

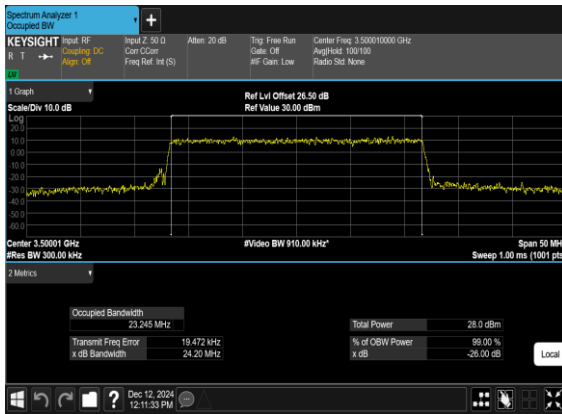

N77(25M)_CP-OFDM_16QAM_Outer_Full_Mid_CH

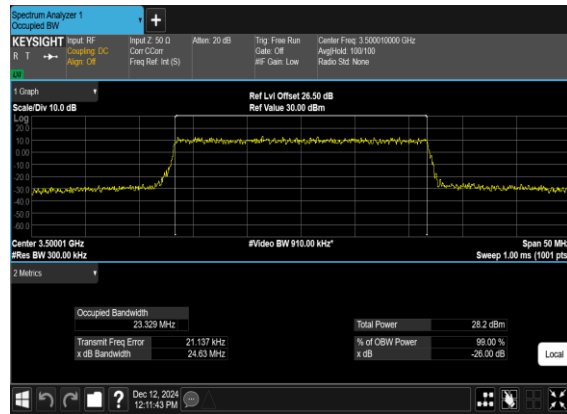

N77(25M)_CP-OFDM_64QAM_Outer_Full_Mid_CH

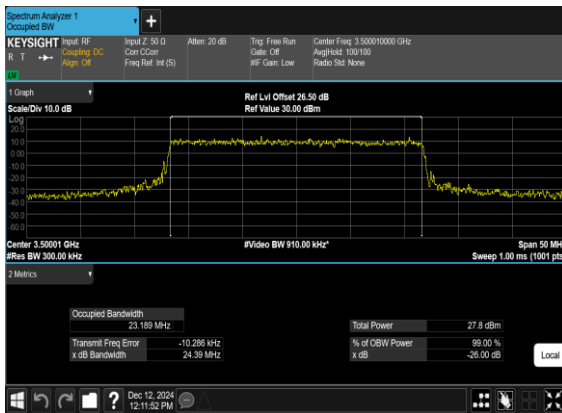

N77(25M)_CP-OFDM_256QAM_Outer_Full_Mid_CH

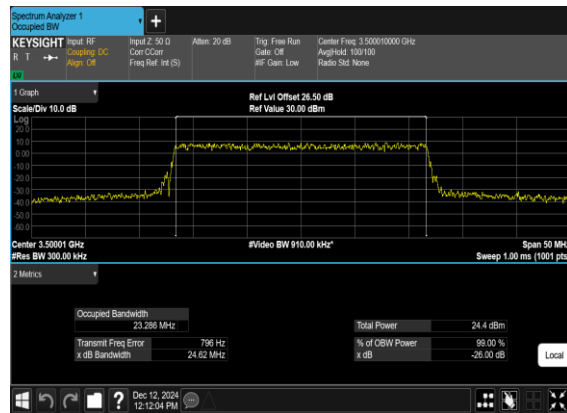



N77(30M)_CP-OFDM_QPSK_Outer_Full_Mid_CH

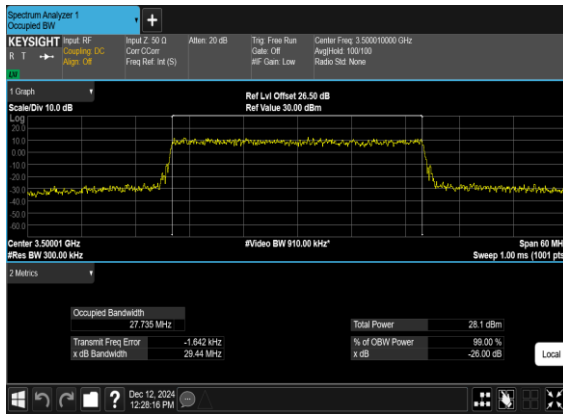

N77(30M)_CP-OFDM_16QAM_Outer_Full_Mid_CH

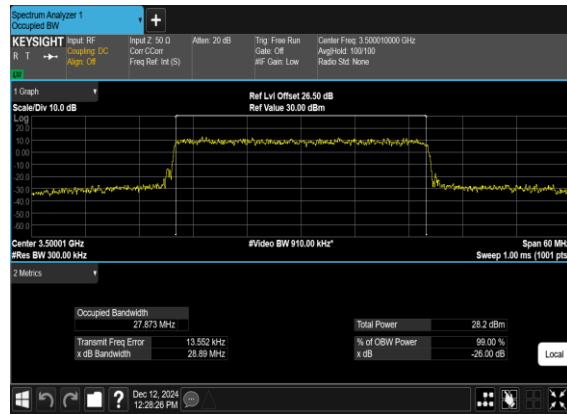

N77(30M)_CP-OFDM_64QAM_Outer_Full_Mid_CH

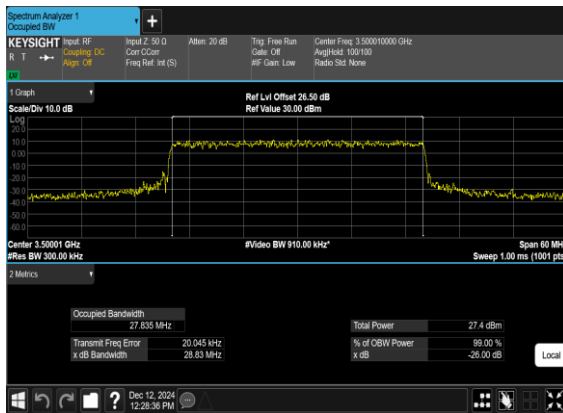

N77(30M)_CP-OFDM_256QAM_Outer_Full_Mid_CH

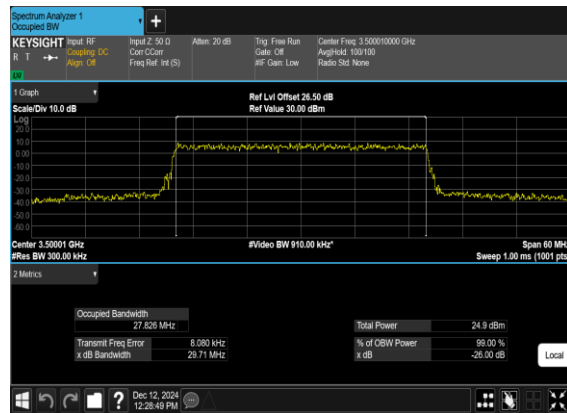



N77(40M)_CP-OFDM_QPSK_Outer_Full_Mid_CH

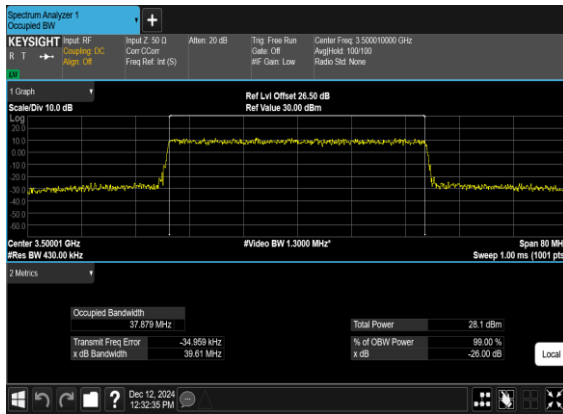

N77(40M)_CP-OFDM_16QAM_Outer_Full_Mid_CH

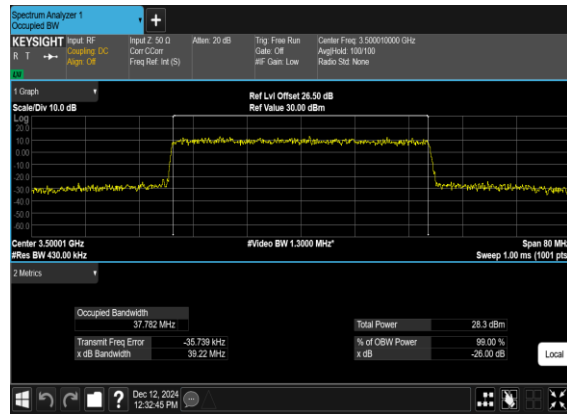

N77(40M)_CP-OFDM_64QAM_Outer_Full_Mid_CH

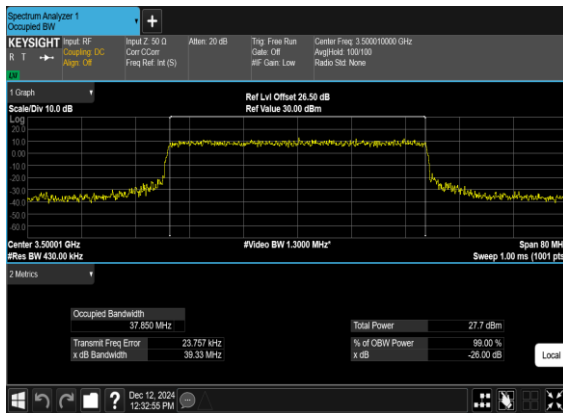

N77(40M)_CP-OFDM_256QAM_Outer_Full_Mid_CH

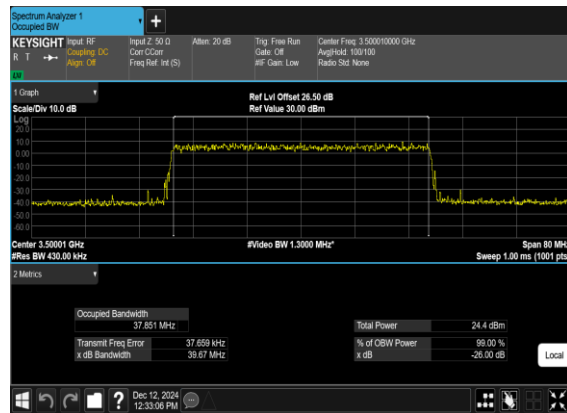



N77(50M)_CP-OFDM_QPSK_Outer_Full_Mid_CH

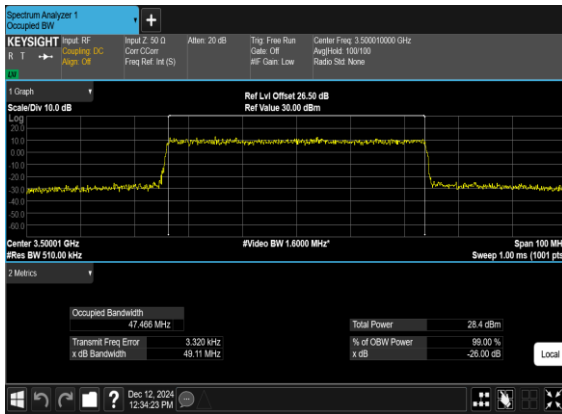

N77(50M)_CP-OFDM_16QAM_Outer_Full_Mid_CH

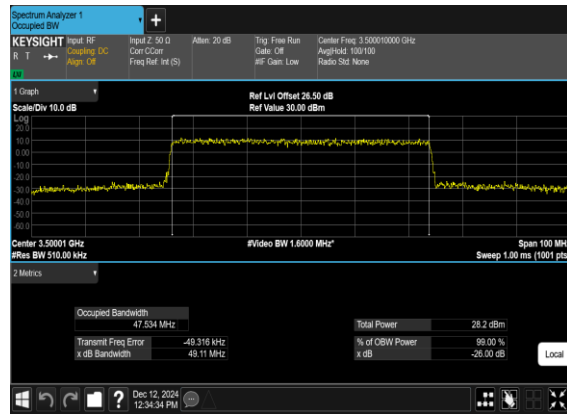

N77(50M)_CP-OFDM_64QAM_Outer_Full_Mid_CH

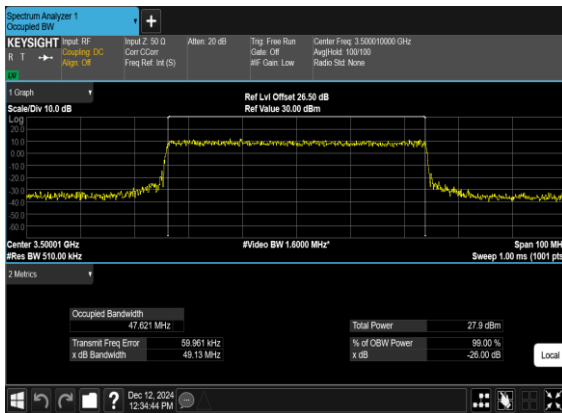

N77(50M)_CP-OFDM_256QAM_Outer_Full_Mid_CH

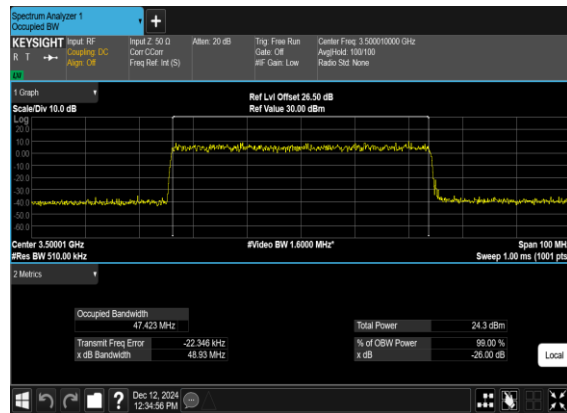



N77(60M)_CP-OFDM_QPSK_Outer_Full_Mid_CH

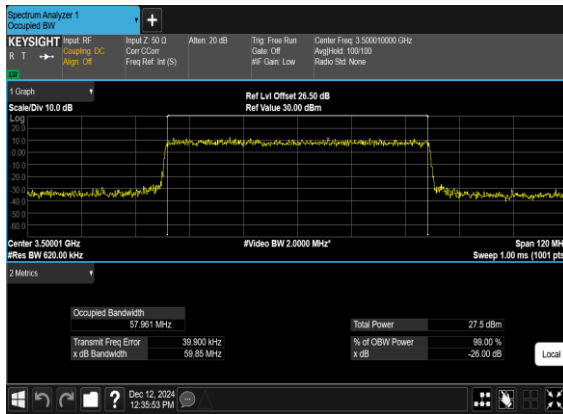

N77(60M)_CP-OFDM_16QAM_Outer_Full_Mid_CH



N77(60M)_CP-OFDM_64QAM_Outer_Full_Mid_CH

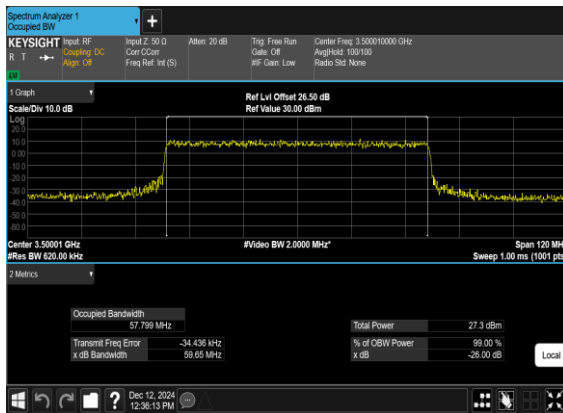

N77(60M)_CP-OFDM_256QAM_Outer_Full_Mid_CH

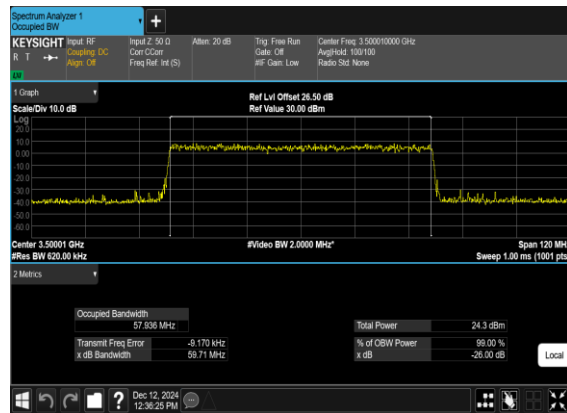



N77(70M)_CP-OFDM_QPSK_Outer_Full_Mid_CH

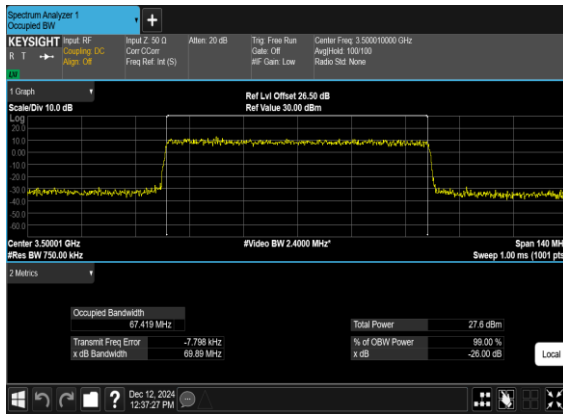

N77(70M)_CP-OFDM_16 QAM_Outer_Full_Mid_CH

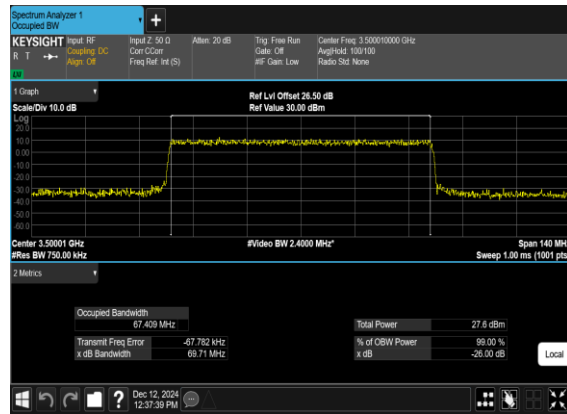

N77(70M)_CP-OFDM_64 QAM_Outer_Full_Mid_CH

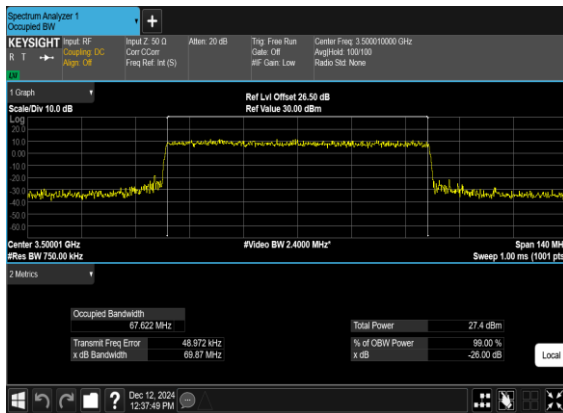

N77(70M)_CP-OFDM_256 QAM_Outer_Full_Mid_CH

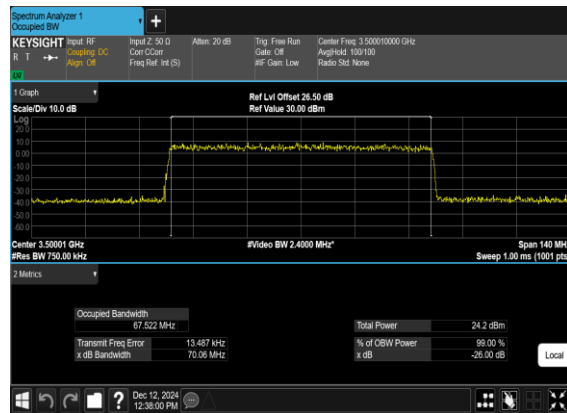



N77(80M)_CP-OFDM_QPSK_Outer_Full_Mid_CH

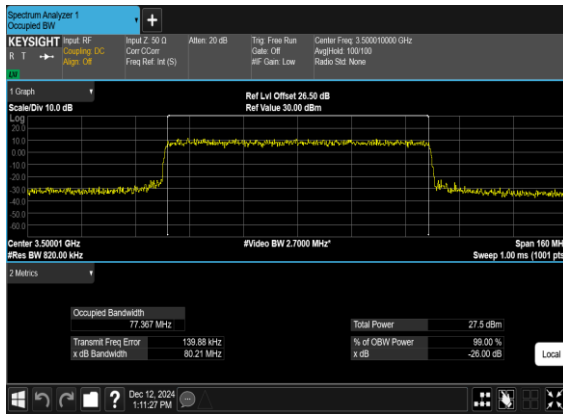

N77(80M)_CP-OFDM_16 QAM_Outer_Full_Mid_CH

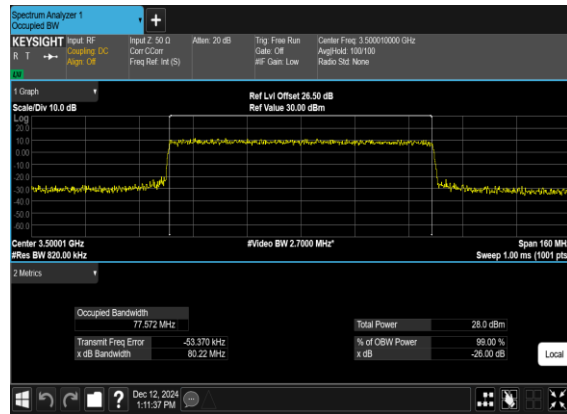

N77(80M)_CP-OFDM_64 QAM_Outer_Full_Mid_CH

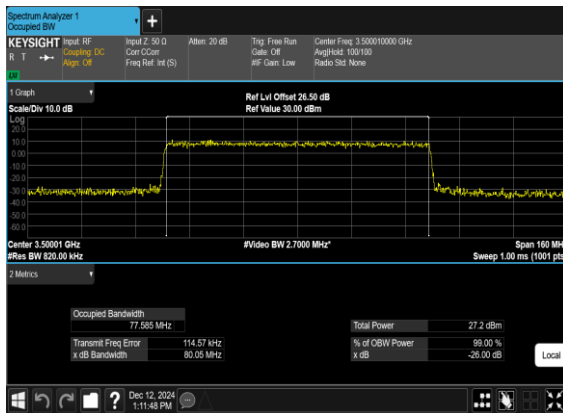

N77(80M)_CP-OFDM_256 QAM_Outer_Full_Mid_CH

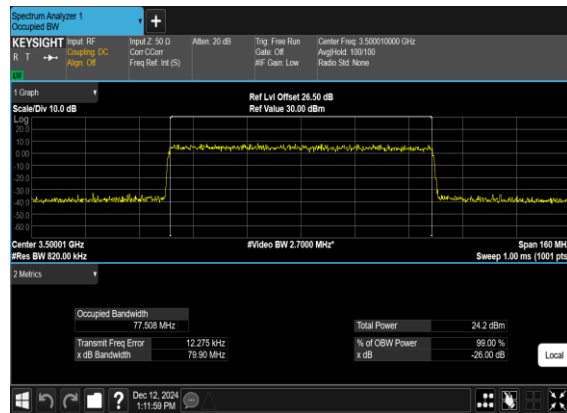



N77(90M)_CP-OFDM_QPSK_Outer_Full_Mid_CH

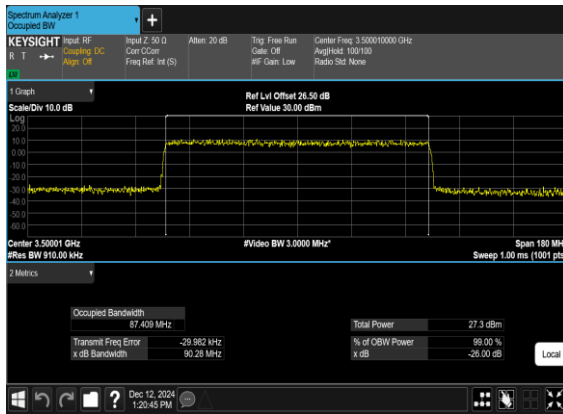

N77(90M)_CP-OFDM_16 QAM_Outer_Full_Mid_CH

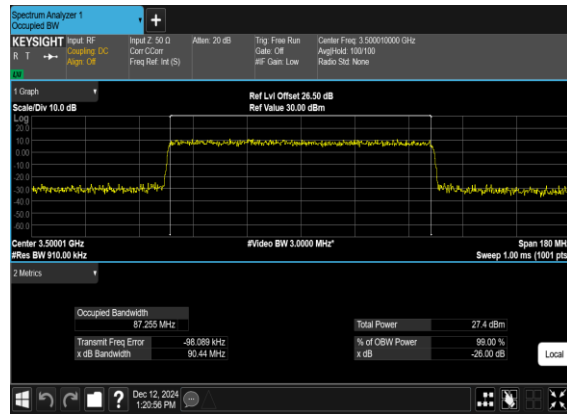

N77(90M)_CP-OFDM_64 QAM_Outer_Full_Mid_CH

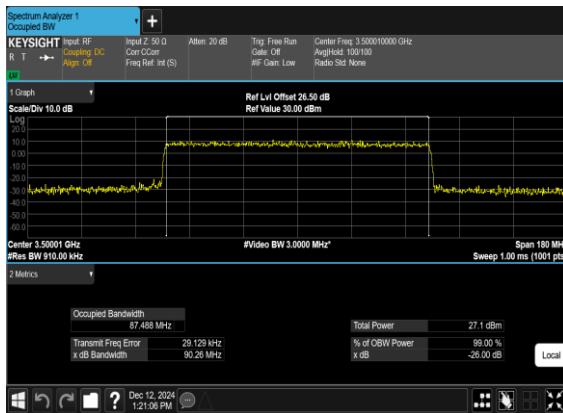

N77(90M)_CP-OFDM_256 QAM_Outer_Full_Mid_CH

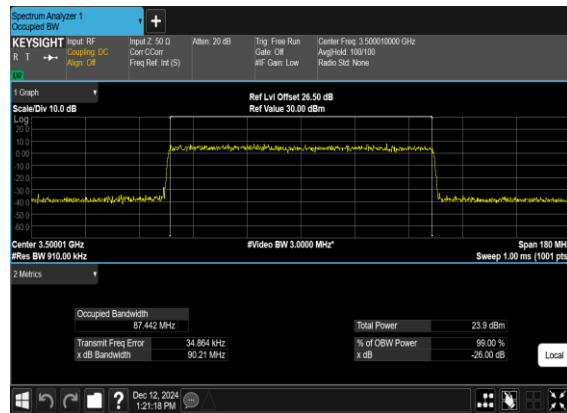



N77(100M)_CP-OFDM_QPSK_Outer_Full_Mid_CH

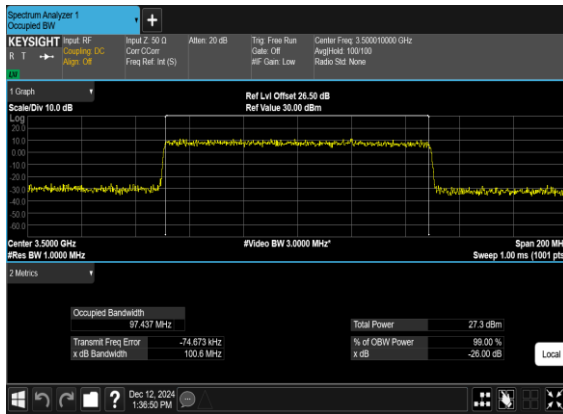

N77(100M)_CP-OFDM_16QAM_Outer_Full_Mid_CH

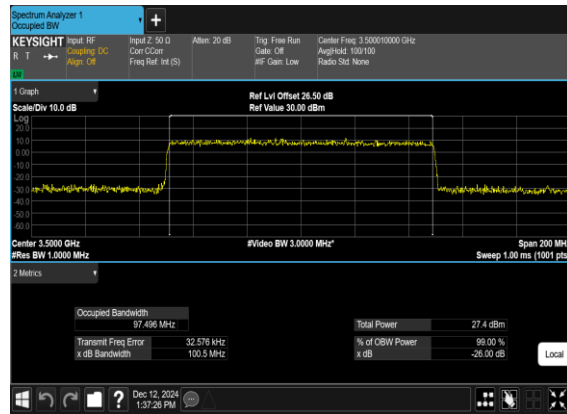

N77(100M)_CP-OFDM_64QAM_Outer_Full_Mid_CH

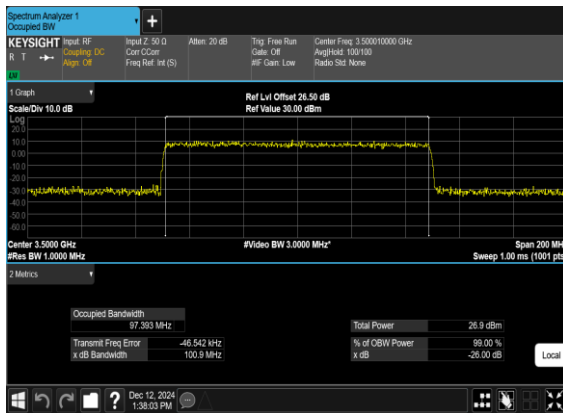

N77(100M)_CP-OFDM_256QAM_Outer_Full_Mid_CH

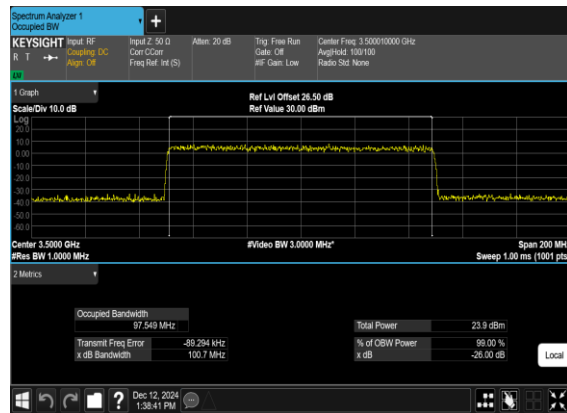



Conducted Spurious Emissions

NR Band	SCS (kHz)	Bandwidth (MHz)	Arfcn	Freq (MHz)	Modulation	RB	Result	Verdict
77	30	10	630334	3455.01	DFT-s-OFDM BPSK	1@0	see graph	---
77	30	10	630334	3455.01	DFT-s-OFDM BPSK	1@0	see graph	PASS
77	30	10	630334	3455.01	DFT-s-OFDM BPSK	1@0	see graph	PASS
77	30	10	630334	3455.01	DFT-s-OFDM QPSK	1@0	see graph	---
77	30	10	630334	3455.01	DFT-s-OFDM QPSK	1@0	see graph	PASS
77	30	10	630334	3455.01	DFT-s-OFDM QPSK	1@0	see graph	PASS
77	30	10	633334	3500.01	DFT-s-OFDM BPSK	1@0	see graph	---
77	30	10	633334	3500.01	DFT-s-OFDM BPSK	1@0	see graph	PASS
77	30	10	633334	3500.01	DFT-s-OFDM BPSK	1@0	see graph	PASS
77	30	10	633334	3500.01	DFT-s-OFDM QPSK	1@0	see graph	---
77	30	10	633334	3500.01	DFT-s-OFDM QPSK	1@0	see graph	PASS
77	30	10	633334	3500.01	DFT-s-OFDM QPSK	1@0	see graph	PASS
77	30	10	636332	3544.98	DFT-s-OFDM BPSK	1@0	see graph	---
77	30	10	636332	3544.98	DFT-s-OFDM BPSK	1@0	see graph	PASS
77	30	10	636332	3544.98	DFT-s-OFDM BPSK	1@0	see graph	PASS
77	30	10	636332	3544.98	DFT-s-OFDM QPSK	1@0	see graph	---
77	30	10	636332	3544.98	DFT-s-OFDM QPSK	1@0	see graph	PASS
77	30	10	636332	3544.98	DFT-s-OFDM QPSK	1@0	see graph	PASS
77	30	50	631668	3475.02	DFT-s-OFDM BPSK	1@0	see graph	---
77	30	50	631668	3475.02	DFT-s-OFDM BPSK	1@0	see graph	PASS



77	30	50	631668	3475.02	DFT-s-OFDM BPSK	1@0	see graph	PASS
77	30	50	631668	3475.02	DFT-s-OFDM QPSK	1@0	see graph	---
77	30	50	631668	3475.02	DFT-s-OFDM QPSK	1@0	see graph	PASS
77	30	50	631668	3475.02	DFT-s-OFDM QPSK	1@0	see graph	PASS
77	30	50	633334	3500.01	DFT-s-OFDM BPSK	1@0	see graph	---
77	30	50	633334	3500.01	DFT-s-OFDM BPSK	1@0	see graph	PASS
77	30	50	633334	3500.01	DFT-s-OFDM BPSK	1@0	see graph	PASS
77	30	50	633334	3500.01	DFT-s-OFDM QPSK	1@0	see graph	---
77	30	50	633334	3500.01	DFT-s-OFDM QPSK	1@0	see graph	PASS
77	30	50	633334	3500.01	DFT-s-OFDM QPSK	1@0	see graph	PASS
77	30	50	635000	3525.0	DFT-s-OFDM BPSK	1@0	see graph	---
77	30	50	635000	3525.0	DFT-s-OFDM BPSK	1@0	see graph	PASS
77	30	50	635000	3525.0	DFT-s-OFDM BPSK	1@0	see graph	PASS
77	30	50	635000	3525.0	DFT-s-OFDM QPSK	1@0	see graph	---
77	30	50	635000	3525.0	DFT-s-OFDM QPSK	1@0	see graph	PASS
77	30	50	635000	3525.0	DFT-s-OFDM QPSK	1@0	see graph	PASS
77	30	100	633334	3500.01	DFT-s-OFDM BPSK	1@0	see graph	---
77	30	100	633334	3500.01	DFT-s-OFDM BPSK	1@0	see graph	PASS
77	30	100	633334	3500.01	DFT-s-OFDM BPSK	1@0	see graph	PASS
77	30	100	633334	3500.01	DFT-s-OFDM QPSK	1@0	see graph	---
77	30	100	633334	3500.01	DFT-s-OFDM QPSK	1@0	see graph	PASS
77	30	100	633334	3500.01	DFT-s-OFDM QPSK	1@0	see graph	PASS



N77(10M)_DFT-s-OFDM_BPSK_Edge_1RB_Left_Low_CH

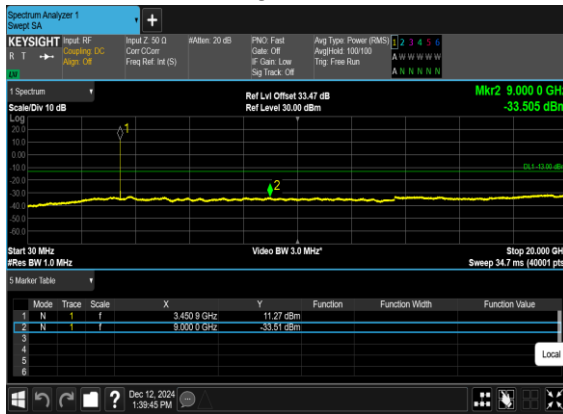

N77(10M)_DFT-s-OFDM_BPSK_Edge_1RB_Left_Low_CH

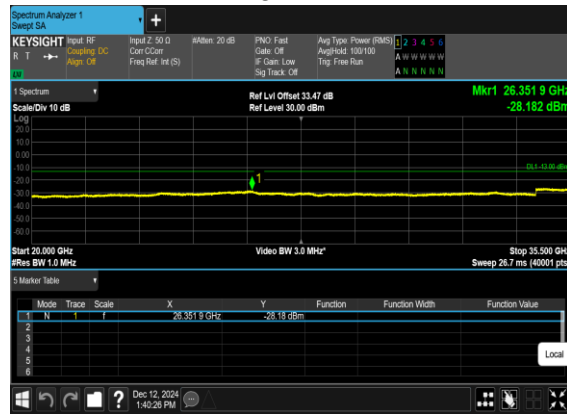

N77(10M)_DFT-s-OFDM_QPSK_Edge_1RB_Left_Low_CH

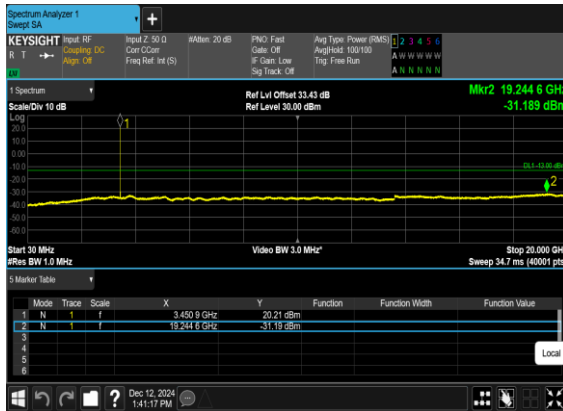

N77(10M)_DFT-s-OFDM_QPSK_Edge_1RB_Left_Low_CH

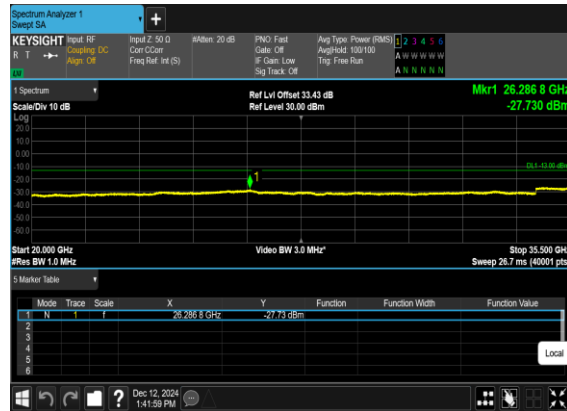



N77(10M)_DFT-s-OFDM_BPSK_Edge_1RB_Left_Mid_CH

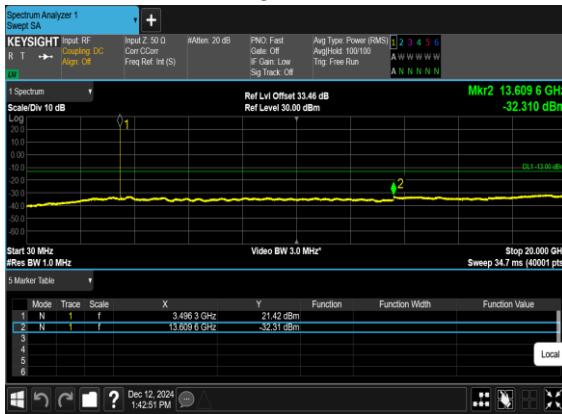

N77(10M)_DFT-s-OFDM_BPSK_Edge_1RB_Left_Mid_CH

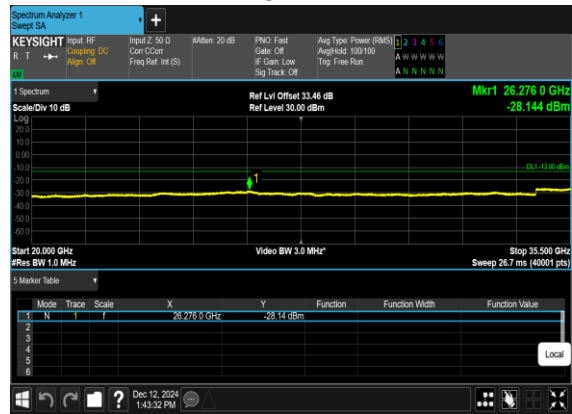

N77(10M)_DFT-s-OFDM_QPSK_Edge_1RB_Left_Mid_CH

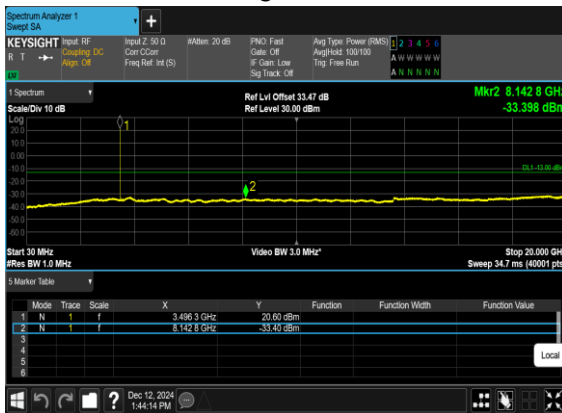

N77(10M)_DFT-s-OFDM_QPSK_Edge_1RB_Left_Mid_CH

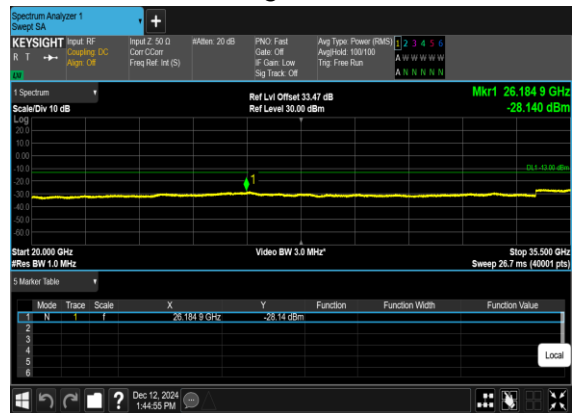



N77(10M)_DFT-s-OFDM_BPSK_Edge_1RB_Left_High_CH

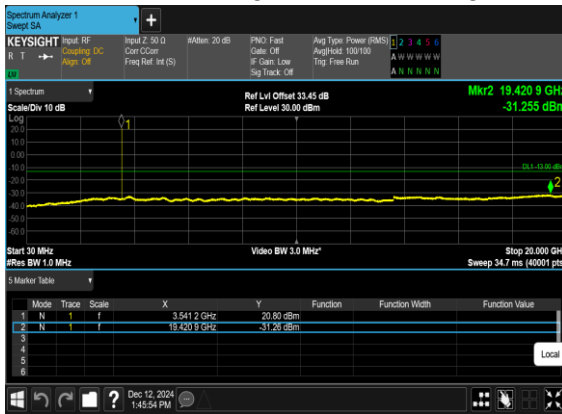

N77(10M)_DFT-s-OFDM_BPSK_Edge_1RB_Left_High_CH

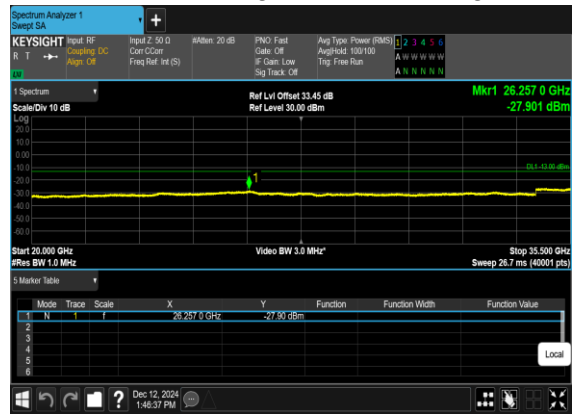

N77(10M)_DFT-s-OFDM_QPSK_Edge_1RB_Left_High_CH

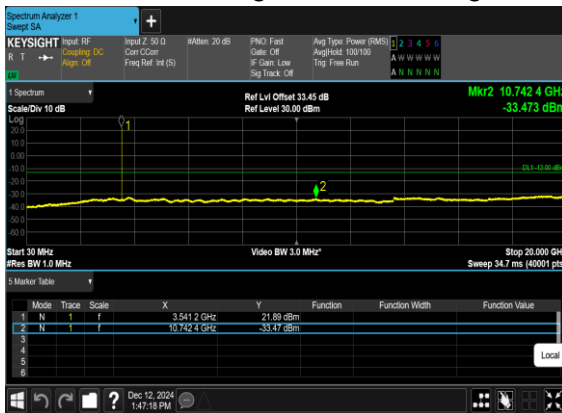

N77(10M)_DFT-s-OFDM_QPSK_Edge_1RB_Left_High_CH

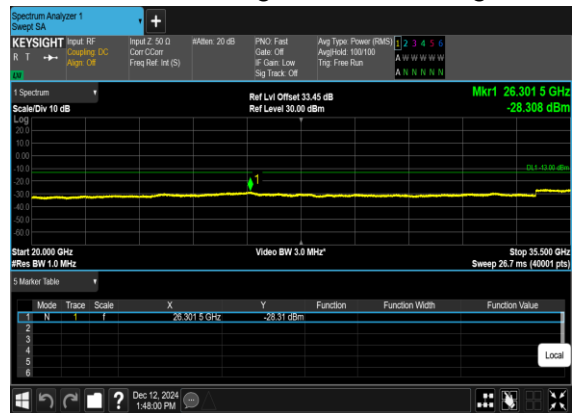



N77(50M)_DFT-s-OFDM_BPSK_Edge_1RB_Left_Low_CH

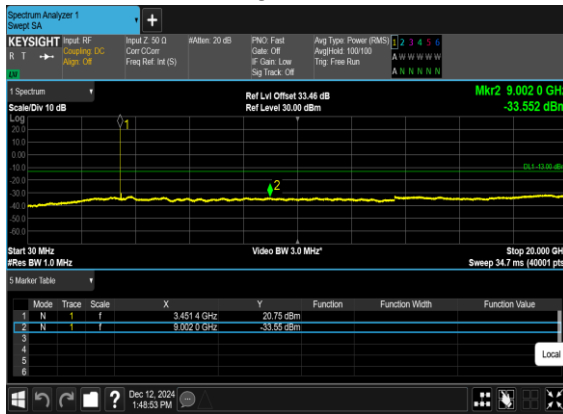

N77(50M)_DFT-s-OFDM_BPSK_Edge_1RB_Left_Low_CH

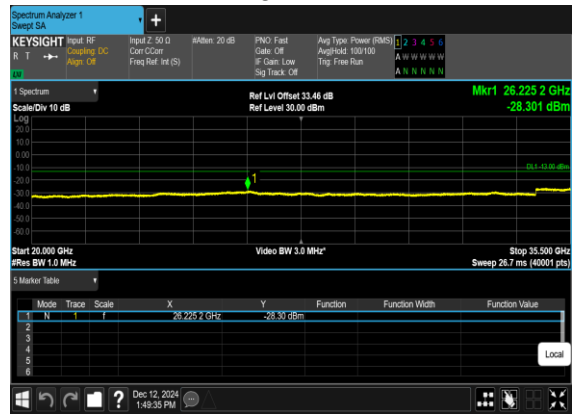

N77(50M)_DFT-s-OFDM_QPSK_Edge_1RB_Left_Low_CH

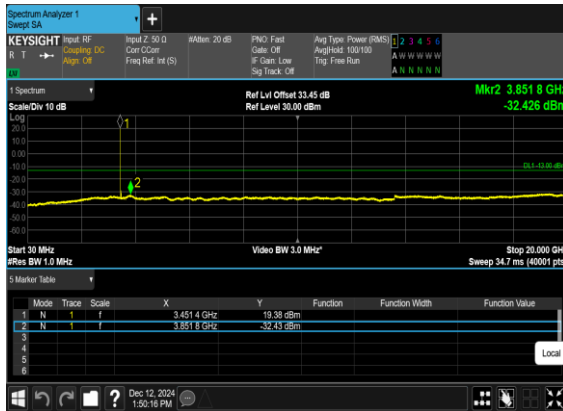

N77(50M)_DFT-s-OFDM_QPSK_Edge_1RB_Left_Low_CH

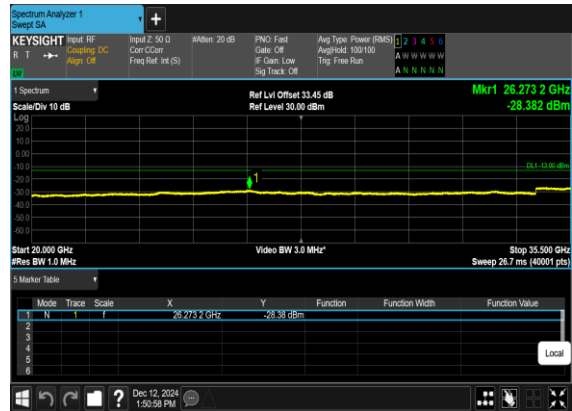



N77(50M)_DFT-s-OFDM_BPSK_Edge_1RB_Left_Mid_CH

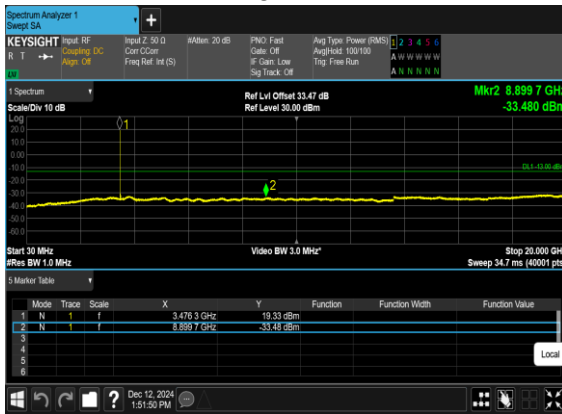

N77(50M)_DFT-s-OFDM_BPSK_Edge_1RB_Left_Mid_CH

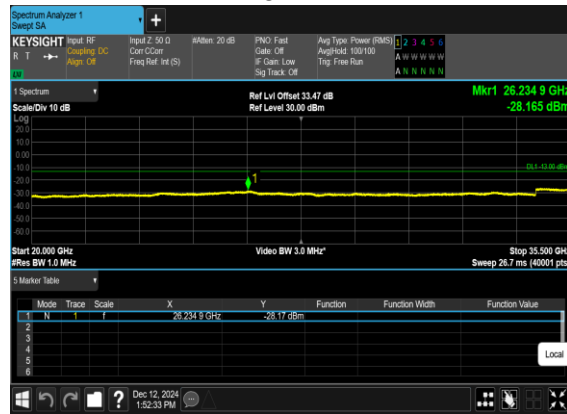

N77(50M)_DFT-s-OFDM_QPSK_Edge_1RB_Left_Mid_CH

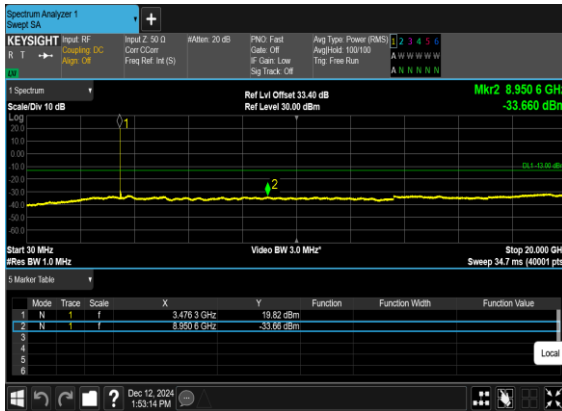

N77(50M)_DFT-s-OFDM_QPSK_Edge_1RB_Left_Mid_CH

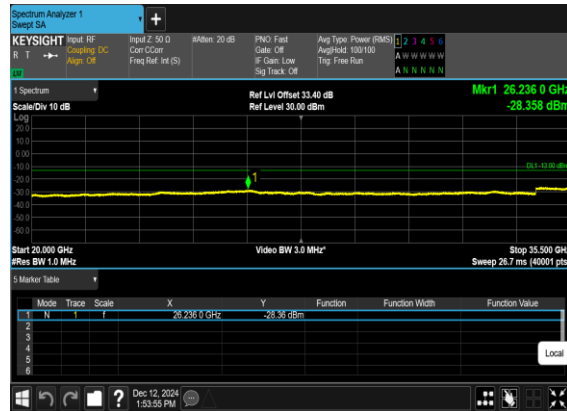



N77(50M)_DFT-s-OFDM_BPSK_Edge_1RB_Left_High_CH

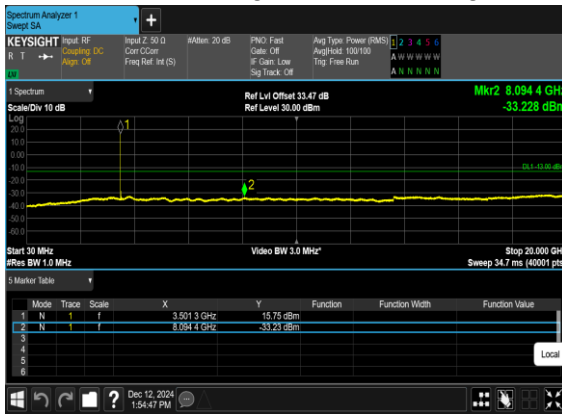

N77(50M)_DFT-s-OFDM_BPSK_Edge_1RB_Left_High_CH

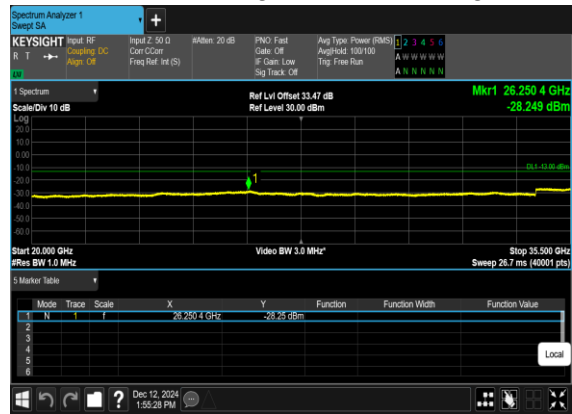

N77(50M)_DFT-s-OFDM_QPSK_Edge_1RB_Left_High_CH

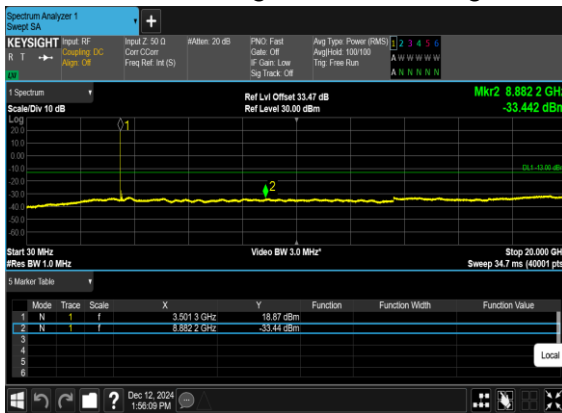

N77(50M)_DFT-s-OFDM_QPSK_Edge_1RB_Left_High_CH

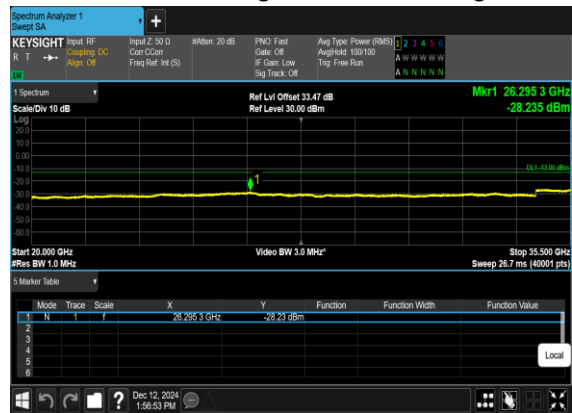



N77(100M)_DFT-s-OFDM_BPSK_Edge_1RB_Left_Mid_CH

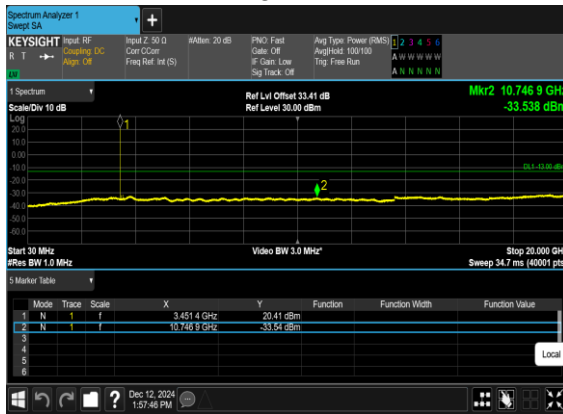

N77(100M)_DFT-s-OFDM_BPSK_Edge_1RB_Left_Mid_CH

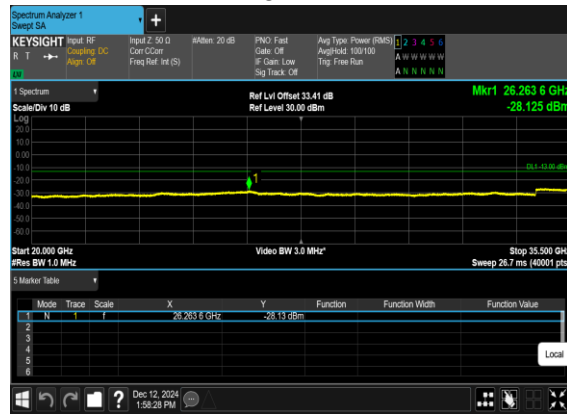

N77(100M)_DFT-s-OFDM_QPSK_Edge_1RB_Left_Mid_CH

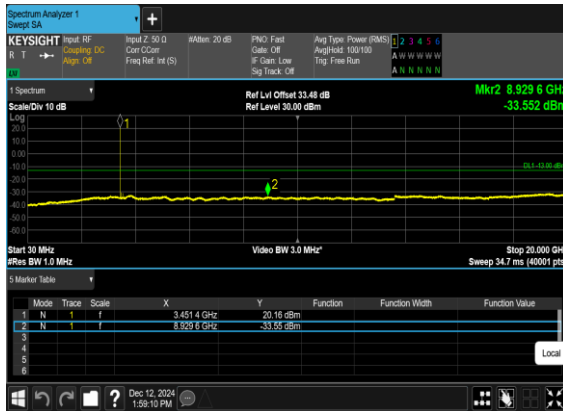

N77(100M)_DFT-s-OFDM_QPSK_Edge_1RB_Left_Mid_CH





Conducted Band Edge

NR Band	SCS (kHz)	Bandwidth (MHz)	Arfcn	Freq (MHz)	Modulation	RB	Result	Verdict
77	30	10	630334	3455.01	DFT-s-OFDM BPSK	1@0	see graph	PASS
77	30	10	630334	3455.01	DFT-s-OFDM QPSK	1@0	see graph	PASS
77	30	10	630334	3455.01	DFT-s-OFDM BPSK	24@0	see graph	PASS
77	30	10	630334	3455.01	DFT-s-OFDM QPSK	24@0	see graph	PASS
77	30	10	636332	3544.98	DFT-s-OFDM BPSK	1@23	see graph	PASS
77	30	10	636332	3544.98	DFT-s-OFDM QPSK	1@23	see graph	PASS
77	30	10	636332	3544.98	DFT-s-OFDM BPSK	24@0	see graph	PASS
77	30	10	636332	3544.98	DFT-s-OFDM QPSK	24@0	see graph	PASS
77	30	50	631668	3475.02	DFT-s-OFDM BPSK	1@0	see graph	PASS
77	30	50	631668	3475.02	DFT-s-OFDM QPSK	1@0	see graph	PASS
77	30	50	631668	3475.02	DFT-s-OFDM BPSK	128@0	see graph	PASS
77	30	50	631668	3475.02	DFT-s-OFDM QPSK	128@0	see graph	PASS
77	30	50	635000	3525.0	DFT-s-OFDM BPSK	1@132	see graph	PASS
77	30	50	635000	3525.0	DFT-s-OFDM QPSK	1@132	see graph	PASS
77	30	50	635000	3525.0	DFT-s-OFDM BPSK	128@0	see graph	PASS
77	30	50	635000	3525.0	DFT-s-OFDM QPSK	128@0	see graph	PASS
77	30	100	633334	3500.01	DFT-s-OFDM BPSK	1@0	see graph	PASS
77	30	100	633334	3500.01	DFT-s-OFDM QPSK	1@0	see graph	PASS
77	30	100	633334	3500.01	DFT-s-OFDM BPSK	1@272	see graph	PASS
77	30	100	633334	3500.01	DFT-s-OFDM QPSK	1@272	see graph	PASS
77	30	100	633334	3500.01	DFT-s-OFDM BPSK	270@0	see graph	PASS
77	30	100	633334	3500.01	DFT-s-OFDM QPSK	270@0	see graph	PASS



N77(10M)_DFT-s-OFDM_BPSK_Edge_1RB_Left_Low_CH

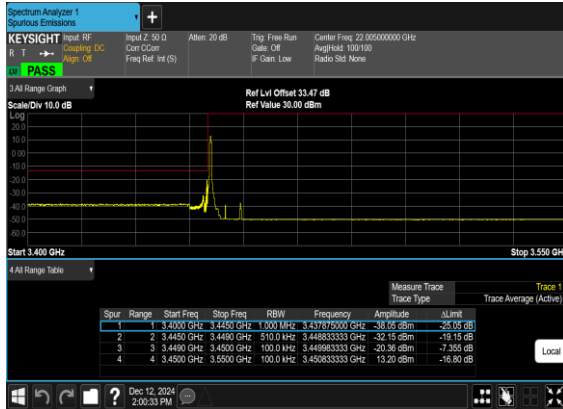

N77(10M)_DFT-s-OFDM_QPSK_Edge_1RB_Left_Low_CH

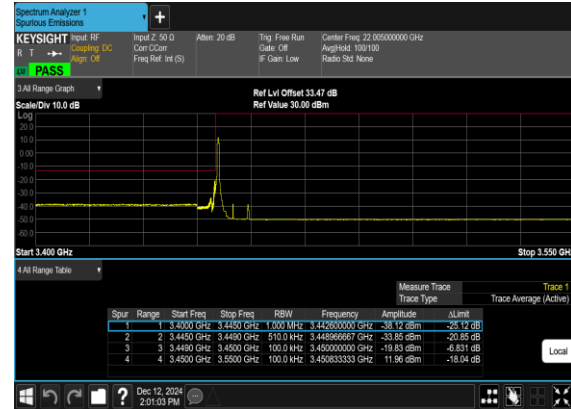

N77(10M)_DFT-s-OFDM_BPSK_Outer_Full_Low_CH

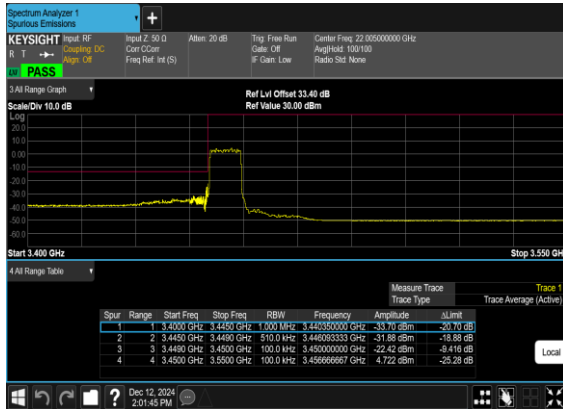

N77(10M)_DFT-s-OFDM_QPSK_Outer_Full_Low_CH





N77(10M)_DFT-s-OFDM_BPSK_Edge_1RB_Right_High_CH

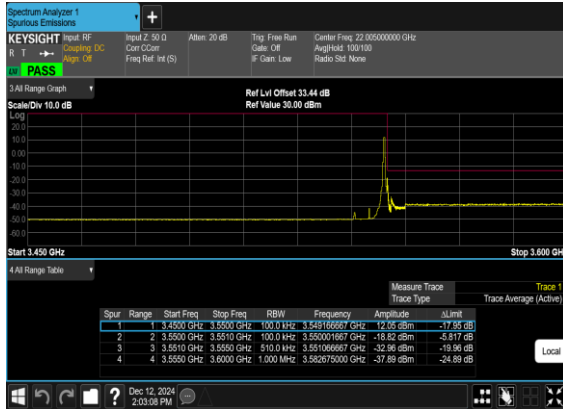

N77(10M)_DFT-s-OFDM_QPSK_Edge_1RB_Right_High_CH

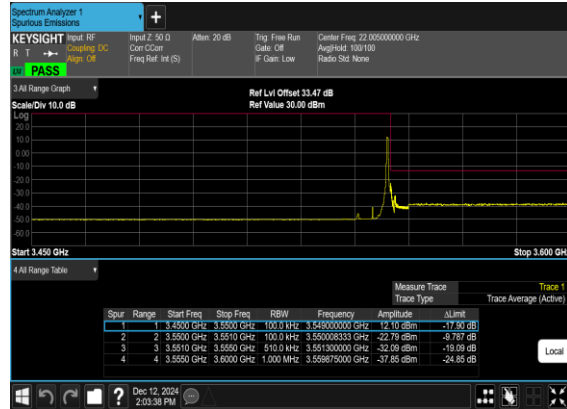

N77(10M)_DFT-s-OFDM_BPSK_Outer_Full_High_CH

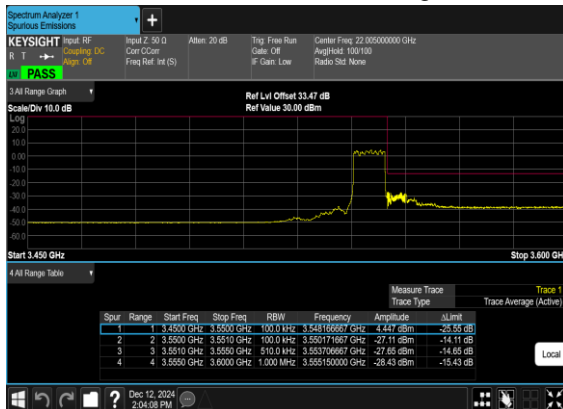

N77(10M)_DFT-s-OFDM_QPSK_Outer_Full_High_CH

