



# FCC TAS validation – Part 2: Tests under dynamic transmit power scenarios

FCC ID : IHDT56AT9  
Equipment : Mobile Cellular Phone  
Brand Name : Motorola  
Model Name : XT2615-1, XT2615-2, XT2615-3, XT2615V  
Applicant : Motorola Mobility LLC  
222 W,Merchandise Mart Plaza, Chicago IL 60654 USA  
Manufacturer : Motorola Mobility LLC  
222 W,Merchandise Mart Plaza, Chicago IL 60654 USA  
Standard : FCC 47 CFR Part 2 (2.1093)

We, Sporton International Inc. (Shenzhen), would like to declare that the tested sample has been evaluated in accordance with the test procedures given in 47 CFR Part 2.1093 and FCC KDB and has been in compliance with the applicable technical standards.

The test results in this report apply exclusively to the tested model / sample. Without written approval of Sporton International Inc. (Shenzhen), the test report shall not be reproduced except in full.

Approved by: Hank Huang

**Sporton International Inc. (Shenzhen)**

**1/F, 2/F, Bldg 5, Shiling Industrial Zone, Xinwei Village, Xili, Nanshan, Shenzhen, 518055**

**People's Republic of China**



Table of Contents

1. Overview ..... 4
2. Operating Parameters for Algorithm Validation ..... 5
3. Overview of TA-SAR Gen2 Test Proposal ..... 6
4. TA-SAR Gen2 Test Scenarios and Test Procedures ..... 7
4.1 Test Sequences for All Scenarios ..... 8
4.2 Test Configuration and Procedure for Scenario 1: Range of TA-SAR Gen2 Parameters via Conducted Power Measurements ..... 12
4.2.1 Configuration ..... 12
4.2.2 Procedure ..... 12
4.3 Test Configuration and Procedure for Scenario 2: Time-Varying TX Power via Conducted Power Measurements ..... 14
4.3.1 Configuration ..... 14
4.3.2 Procedure ..... 15
4.4 Test Configuration and Procedure for Scenario 3: Call Disconnection and Re-establishment via Conducted Power Measurements ..... 17
4.4.1 Configuration ..... 17
4.4.2 Procedure ..... 17
4.5 Test Configuration and Procedure for Scenario 4: Band Handover via Conducted Power Measurements ..... 19
4.5.1 Configuration ..... 19
4.5.2 Procedure ..... 19
4.6 Test Configuration and Procedure for Scenario 5: Exposure Condition Index (ECI) Change via Conducted Power Measurements ..... 21
4.6.1 Configuration ..... 21
4.6.2 Procedure ..... 21
4.7 Test Configuration and Procedure for Scenario 6: Antenna Switching via Conducted Power Measurements ..... 22
4.7.1 Configuration ..... 22
4.7.2 Procedure ..... 22
4.8 Test Configuration and Procedure for Scenario 7: Time Window Switching via Conducted Power Measurements ..... 23
4.8.1 Configuration ..... 23
4.8.2 Procedure ..... 23
4.9 Test Configuration and Procedure for Scenario 8: SAR Exposure Switching via Conducted Power Measurements ..... 26
4.9.1 Configuration ..... 26
4.9.2 Procedure ..... 27
4.10 Test Configuration and Procedure for Scenario 2: Time-Varying TX Power via SAR Measurements ..... 29
4.10.1 Configuration ..... 29
4.10.2 Procedure ..... 29
5. TA-SAR Gen2 Validation via Conducted Power Measurements ..... 31
5.1 Measurement Setup ..... 31
5.1.1 Test Bench Introduction ..... 31
5.1.2 Sub6 NR/LTE/3G/2G Power Limit Table and Test Configurations ..... 34
5.2 Conducted Power Measurement Results for Scenario1: Range of TA-SAR Gen2 Parameters ..... 40
5.3 Conducted Power Measurement Results for Scenario 2: Time-Varying TX Power ..... 41
5.3.1 Measurement results for 2G ..... 41
5.3.2 Measurement results for 3G ..... 45
5.3.3 Measurement results for LTE ..... 49
5.3.4 Measurement results for NR ..... 53
5.4 Conducted Power Measurement Results for Scenario 3: Call Disconnection and Re-establishment ..... 57
5.5 Conducted Power Measurement Results for Scenario 4: Band Handover ..... 58
5.6 Conducted Power Measurement Results for Scenario 5: ECI Change ..... 59
5.7 Conducted Power Measurement Results for Scenario 7: Time Window Switching ..... 60
5.7.1 Measurement results for Time window switching 60s-100s-60s ..... 60
5.7.2 Measurement results for Time window switching 100s-60s-100s ..... 61
5.8 Conducted Power Measurement Results for Scenario 8: SAR Exposure Switching (EN-DC Combination in the same time window) ..... 62
5.9 Conducted Power Measurement Results for Scenario 8: SAR Exposure Switching (EN-DC Combination in the different time window) ..... 63
6. TA-SAR Gen2 Validation via SAR Measurements ..... 64
6.1 Measurement Setup ..... 64
6.2 SAR Measurement Results for Scenario 2: Time-Varying TX Power ..... 65
6.2.1 SAR Measurement results for 2G ..... 66
6.2.2 SAR Measurement results for 3G ..... 70
6.2.3 SAR Measurement results for LTE ..... 74
6.2.4 SAR Measurement results for NR ..... 78
7. Conclusions ..... 82
8. cDASY6 System Verification ..... 83
8.1 The system to be used for the near field power density measurement ..... 83
8.2 Test Site Location ..... 83
8.3 SAR E-Field Probe ..... 84
8.4 Data Acquisition Electronics (DAE) ..... 84
9. Test Equipment List ..... 85
10. System verification and validation ..... 86
10.1 Tissue Verification ..... 86
10.2 System Verification ..... 86
11. Uncertainty Assessment ..... 87
Appendix A. Plots of System Performance Check ..... 89
Appendix B. DASY Calibration Certificate ..... 89
Appendix C. Test Setup Photos ..... 89





1. Overview

FCC regulation allows time averaged RF power to demonstrate compliance to RF exposure safety limits. Because RF exposure is correlated to transmission power (TX power), e.g., lower RF exposure is correlated to lower TX power, the TX power can be controlled to meet FCC RF exposure limits defined specific absorption rate (SAR) limit for transmit frequencies < 6GHz. For SAR limit, the proposed Time-Averaged Specific Absorption Rate (TA-SAR) Gen2 algorithm manages TX power to ensure that at all times the time-averaged RF exposure is compliant with the FCC SAR requirement. In the FCC regulation, the averaging window of SAR is 100 seconds for transmit frequencies less than 3GHz, 60 seconds for transmit frequencies between 3GHz and 6GHz.

This purpose of the Part 2 report is to demonstrate the EUT complies with FCC RF exposure requirement under Tx varying transmission scenarios, thereby validity of MediaTek’s TAS feature for FCC equipment authorization. It serves to compliment the Part 0 and Part 1 Test Reports to justify compliance per FCC.

The Plimit used in this report is determined in Part 0 and Part 1 report.

<Test Lab Information>

Sporton International Inc. (Shenzhen) is accredited to ISO/IEC 17025:2017 by American Association for Laboratory Accreditation with Certificate Number 5145.01.

Table with 2 columns: Test Firm Name, Test Firm Information, FCC Designation No., Test Firm Registration Number for FCC, Test Site No., IMEI Code, Date of Start during the Test, Date of End during the Test, Test Engineers. Values include Sporton International Inc. (Shenzhen), 1/F, 2/F, Bldg 5, Shiling Industrial Zone, CN1256, 421272, SAR02-SZ, 351515260026374/351515260026382, 2025/6/25, 2025/7/10, Bran Yin/Seth Jin.

## 2. Operating Parameters for Algorithm Validation

Mediatek developed the TA-SAR Gen2 algorithm V2.2439.1 to control instantaneous TX power for transmit frequencies less and larger than 6GHz respectively, so that the total time-averaged RF exposures are less than FCC requirement.

TA-SAR Gen2 algorithm validation has been performed for 2G, 3G, LTE, NR FR1 according to cases with different combinations of operating parameters listed in Table 2-1.

**Table 2-1 TA-SAR Gen2 operating parameters**

Operating parameters	Description
$P_{sub6\_limit}$	The time-averaged maximum power level limit for different bands for 2G, 3G, LTE, and NR FR1.
$P_{LowThresh\_offset}$	To calculate $P_{LowThresh}$ . ( $P_{LowThresh} = P_{sub6\_limit} - P_{LowThresh\_offset}$ )
$P_{UE\_backoff\_offset}$	To calculate $P_{UE\_backoff}$ . ( $P_{UE\_backoff} = P_{sub6\_limit} - P_{UE\_backoff\_offset}$ )
$P_{UE\_max\_cust\_offset}$	To calculate $P_{UE\_max\_cust}$ . $P_{UE\_max}$ is maximum TX power at which a UE can possibly transmit. $P_{UE\_max\_cust} = \min(P_{UE\_max}, P_{sub6\_limit} + P_{UE\_max\_cust\_offset})$
$SPLSR\_group$	Sub6 antenna group index
$Level\_num_{sub6\_pwr}$	The number of backoff levels constraining sub6 instantaneous TX power.
$Algo\_avg\_window_{sub6}$	The time-averaged window used by TA-SAR Gen2 algorithm.

### **3. Overview of TA-SAR Gen2 Test Proposal**

For the completeness of verifying that the proposed TA-SAR Gen2 algorithm can realize FCC compliance regarding RF exposure, several test scenarios are constructed as below:

- **Scenario 1:** test under different TA-SAR Gen2 parameters to verify that the TA-SAR Gen2 algorithm meets compliance requirements with different combinations of operating parameters.
- **Scenario 2:** test under time-varying TX power to verify that the TA-SAR Gen2 algorithm ensures SAR compliance through dynamic TX power.
- **Scenario 3:** test under call drop and re-establishment conditions to ensure the TA-SAR Gen2 algorithm control continuity and SAR compliance.
- **Scenario 4:** test under RAT/band handover to ensure the TA-SAR Gen2 algorithm control continuity and correctness.
- **Scenario 5:** test under different ECIs (Exposure Condition Index) to ensure the TA-SAR Gen2 algorithm control behaves as expected during ECI switching from one ECI to another. (e.g., head→ body worn)
- **Scenario 6:** test under different transmission antennae to ensure the TA-SAR Gen2 algorithm control works correctly during antenna switching from one antenna to another.
- **Scenario 7:** test under different time windows to ensure the TA-SAR Gen2 algorithm control functions correctly during time window switching from one time window setting to another. (e.g., time window 100s→60s)
- **Scenario 8:** test under SAR exposure switching between two active radios (radio#1 only, radio#1+radio#2, and radio#2 only) to ensure the TA-SAR Gen2 algorithm control continuity and SAR compliance.

For TA-SAR Gen2 validation, description of the conducted power measurement test procedures is included in section 4.2~4.9, and description of the SAR measurement test procedures is included in section 4.10. In each of the test scenarios, certain test sequence, described in section 4.1, is applied.

#### 4. TA-SAR Gen2 Test Scenarios and Test Procedures

In order to demonstrate that TA-SAR Gen2 algorithm performs as expected under various operating scenarios, Table 4-1 lists the test scenarios and expected test sequences to validate TA-SAR Gen2 algorithm in these scenarios. The test sequences 0, 1, 2 are defined in section 4.1. The details of each test procedures via conducted power and SAR measurements are described in section 4.2~4.9 and section 4.10, respectively.

**Table 4-1 Test scenario list of TA-SAR Gen2 algorithm validation**

Test scenario		Test sequences #	Description
1	Range of TA-SAR Gen2 parameters	0	Adjust parameters
2	Time-varying TX power	1 and 2	Test under time-varying TX power
3	Call disconnection and re-establishment	0	Test call drop and re-establishment
4	Band handover	0	Test band change
5	EI (Exposure Condition Index) change	0	Test under EI transition (e.g., head→ body worn)
6	Antenna switching	0	Change antenna
7	Time window switching	0	Switch frequency bands with larger frequency separation (e.g., time window 100s→60s)
8	SAR exposure switching	0	Switch RATs when testing (e.g., LTE→NR)

**Note:** for each test scenario, only need to test within a SPLSR group, since the results should be highly similar for other SPLSR groups.

## 4.1 Test Sequences for All Scenarios

Three test sequences having possibly time-varying TX power are predefined for TA-SAR Gen2 validation:

- **Test sequence 0:** EUT's TX power is requested to be maximum.
- **Test sequence 1:** EUT's TX power is requested to be at power less than  $P_{LowThresh}$  for 300s, then at maximum power for 200s, and finally at  $P_{LowThresh} - 2\text{dB}$  for the remaining time.
- **Test sequence 2:** EUT's TX power to vary with time. This sequence is generated relative to measured  $P_{UE\_max}$ , measured  $P_{sub6\_limit}$  and calculated  $P_{UE\_backoff}$  (= measured  $P_{sub6\_limit}$  in dBm -  $P_{UE\_backoff\_offset}$  in dB) of EUT based on measured  $P_{sub6\_limit}$ .
- Test sequence is generated based on below parameters of the EUT:
  - A. Measured maximum power ( $P_{UE\_max}$ )
  - B. Measured Tx\_power\_at\_SAR\_design\_limit ( $P_{sub6\_limit}$ )
  - C. Threshold of dynamic power reduction status determination: reserve hysteresis margin for instantaneous power ( $P_{LowThresh}$ )
  - D. SAR\_time\_window (FCC: 100s for  $f < 3\text{GHz}$ , 60s for  $3\text{GHz} < f < 6\text{GHz}$ )

The test sequence 0, 1, and 2 are illustrated in Figure 4-1, Figure 4-2, and Figure 4-3, respectively. The waveforms of the three test sequences are listed in Table 4-2, Table 4-3, and Table 4-4.

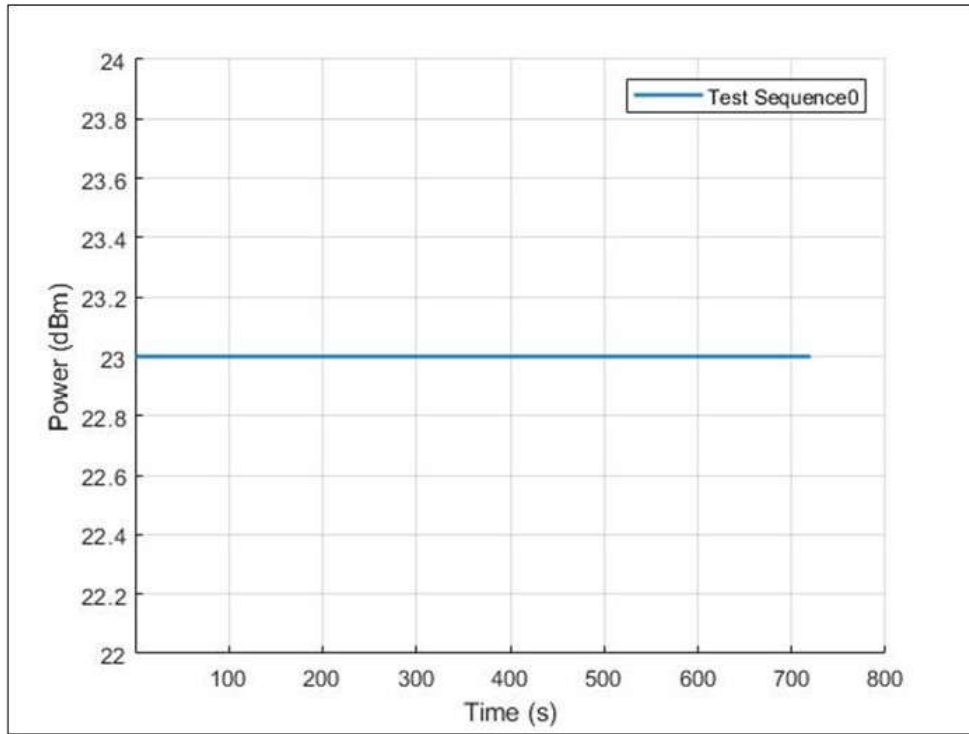

Figure 4-1 Test sequence 0

Table 4-2 Test sequence 0

Time	Duration	Power (dBm)	Note
720	720	23	$P_{UE\_max}$

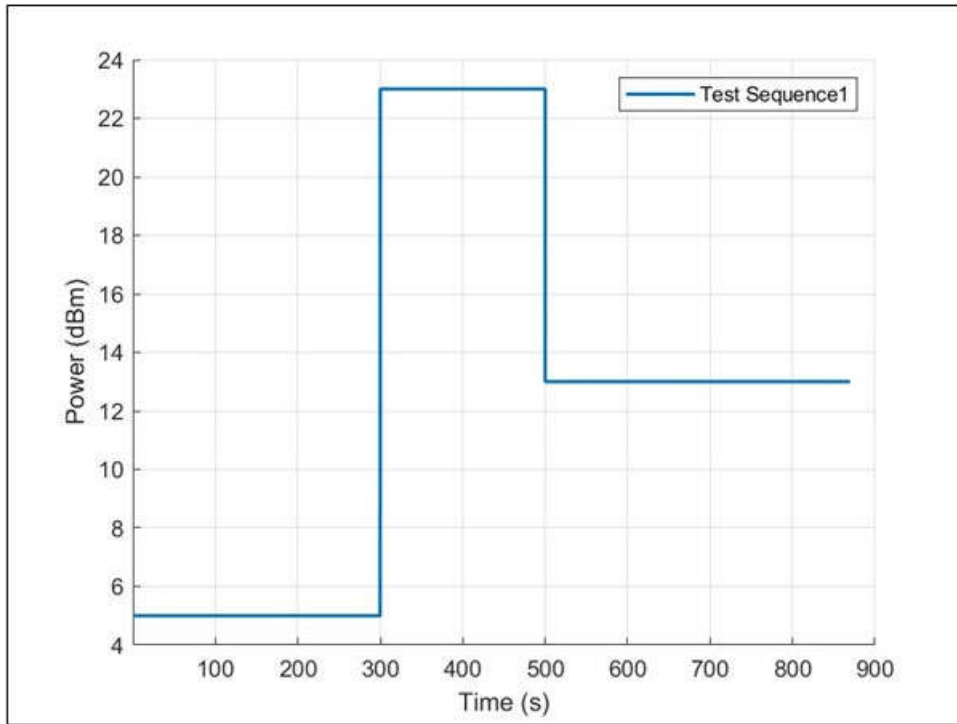

Figure 4-2 Test sequence 1

Table 4-3 Test sequence 1

Time	Duration	Power (dBm)	Note
300	300	5	$< P_{sub6\_limit} - 0.5dB$
500	200	23	$P_{UE\_max}$
870	370	13	$P_{sub6\_limit} - 2.5dB$

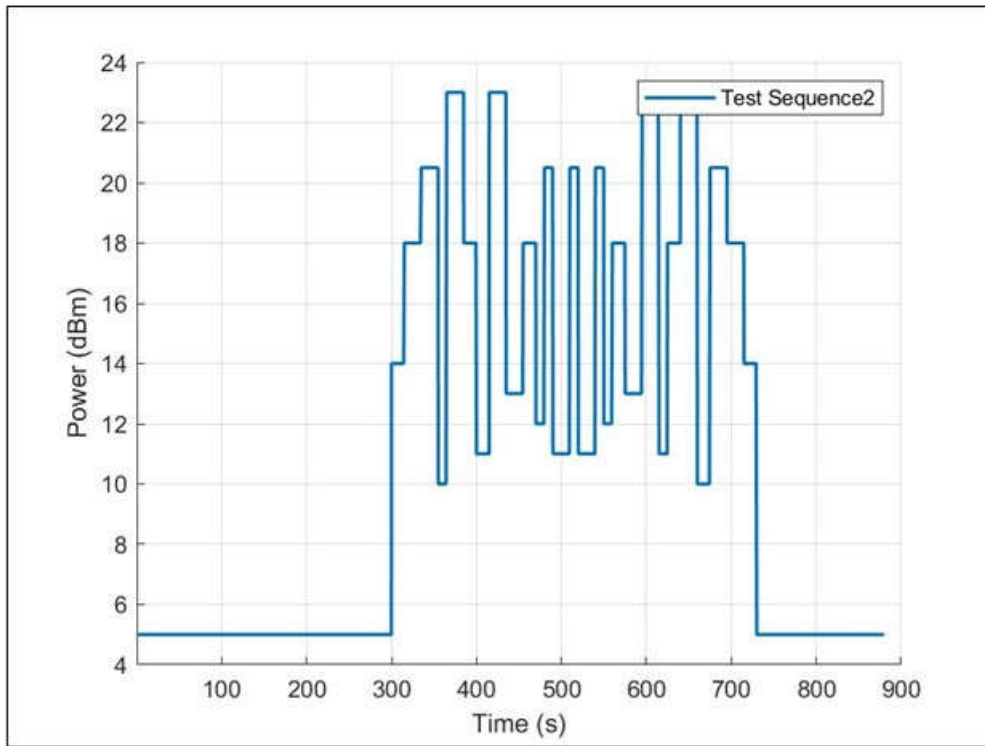

Figure 4-3 Test sequence 2

Table 4-4 Test sequence 2

Time	Duration	Power (dBm)	Note
300	300	5	$< P_{sub6\_limit} - 0.5dB$
315	15	14	$P_{sub6\_limit} - 4dB$
335	20	18	$P_{sub6\_limit}$
355	20	20.5	$(P_{sub6\_limit} + P_{UE\_max})/2$
365	10	10	$P_{sub6\_limit} - 8dB$
385	20	23	$P_{UE\_max}$
400	15	18	$P_{sub6\_limit}$
415	15	11	$P_{sub6\_limit} - 7dB$
435	20	23	$P_{UE\_max}$
455	20	13	$P_{sub6\_limit} - 5dB$
470	15	18	$P_{sub6\_limit}$
480	10	12	$P_{sub6\_limit} - 6dB$
490	10	20.5	$(P_{sub6\_limit} + P_{UE\_max})/2$
510	20	11	$P_{sub6\_limit} - 7dB$
520	10	20.5	$(P_{sub6\_limit} + P_{UE\_max})/2$
540	20	11	$P_{sub6\_limit} - 7dB$
550	10	20.5	$(P_{sub6\_limit} + P_{UE\_max})/2$
560	10	12	$P_{sub6\_limit} - 6dB$
575	15	18	$P_{sub6\_limit}$
595	20	13	$P_{sub6\_limit} - 5dB$
615	20	23	$P_{UE\_max}$
625	10	11	$P_{sub6\_limit} - 7dB$
640	15	18	$P_{sub6\_limit}$
660	20	23	$P_{UE\_max}$
675	15	10	$P_{sub6\_limit} - 8dB$

695	20	20.5	$(P_{sub6\_limit} + P_{UE\_max})/2$
715	20	18	$P_{sub6\_limit}$
730	15	14	$P_{sub6\_limit} - 4dB$
870	140	5	$< P_{sub6\_limit} - 0.5dB$

## 4.2 Test Configuration and Procedure for Scenario 1: Range of TA-SAR Gen2 Parameters via Conducted Power Measurements

### 4.2.1 Configuration

This test is performed by changing the parameters ( $P_{LowThresh\_offset}$ ,  $P_{UE\_backoff\_offset}$ ,  $P_{UE\_max\_cust\_offset}$ ,  $Level\_num_{sub6\_pwr}$ ,  $Algo\_avg\_window_{sub6}$ ) for the selected RAT (Radio Access Technologies) and band. Since Mediatek’s TA-SAR Gen2 algorithm operation is independent of RATs/bands/channels /modulation/bandwidth (RBs), any one RAT can be selected for this test and the selected band of the RAT has the least  $P_{sub6\_limit}$ . In principle, two sets of the parameters are determined for this test (if applicable). If the parameters of the EUT are fixed (without a support of dynamic change), only the set of the default parameters needs to be tested.

### 4.2.2 Procedure

TX power is measured, recorded, and processed by the following steps:

- Step 1~4: measure and record TX power versus time for test scenario 1

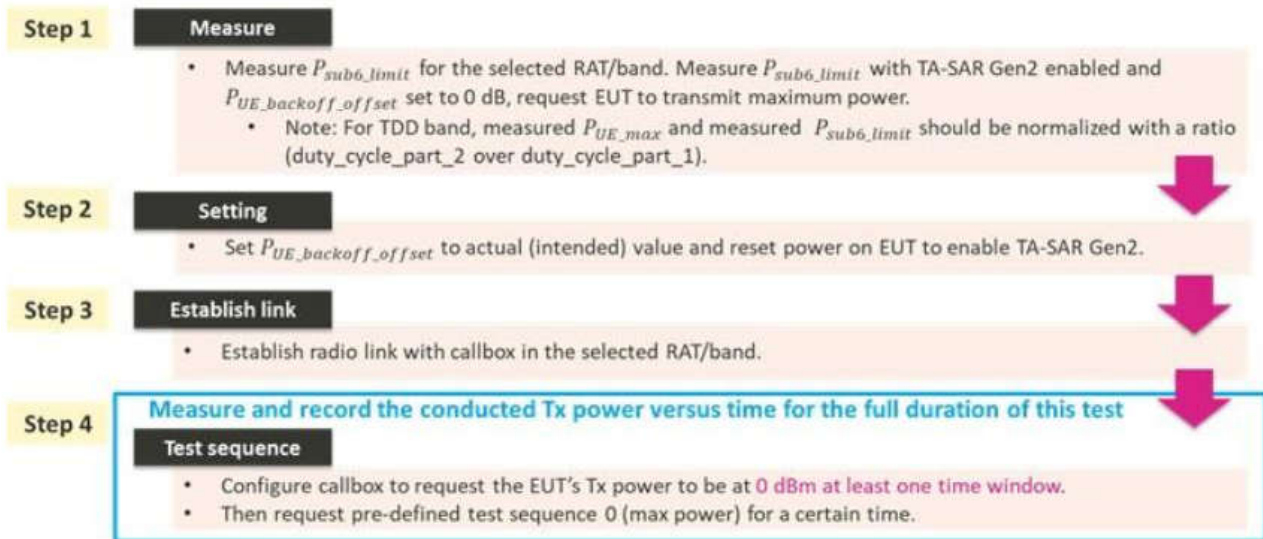

- Step 5: convert the measured conducted TX power into SAR

Convert the measured conducted TX power from step 4 into 1gSAR or 10gSAR value, and perform the running time average on the conducted TX power and 1gSAR or 10g SAR to determine the time-averaged TX power or SAR by using the following equations.

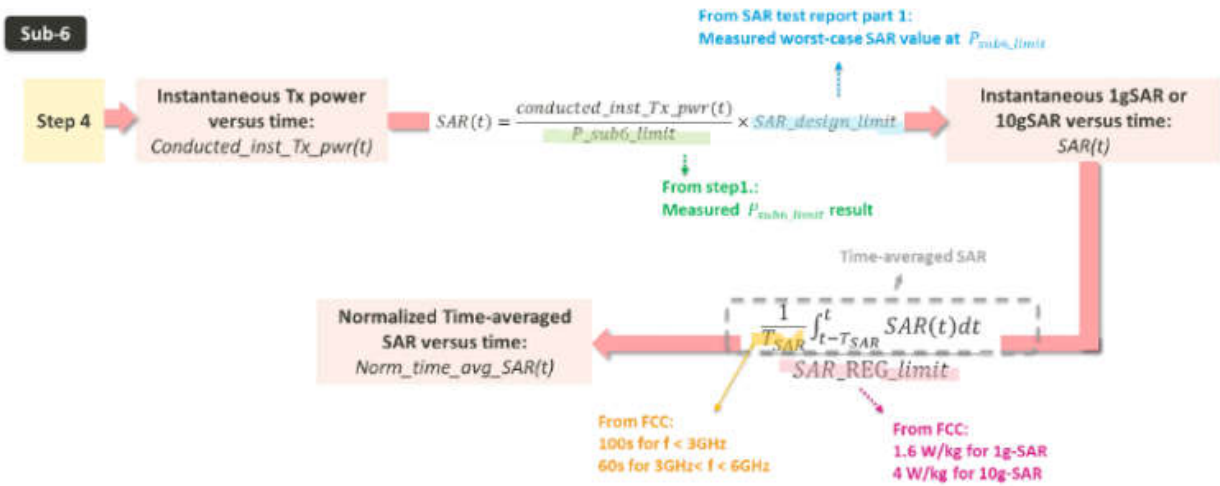

Specifically, the running time average is illustrated with the below figure.

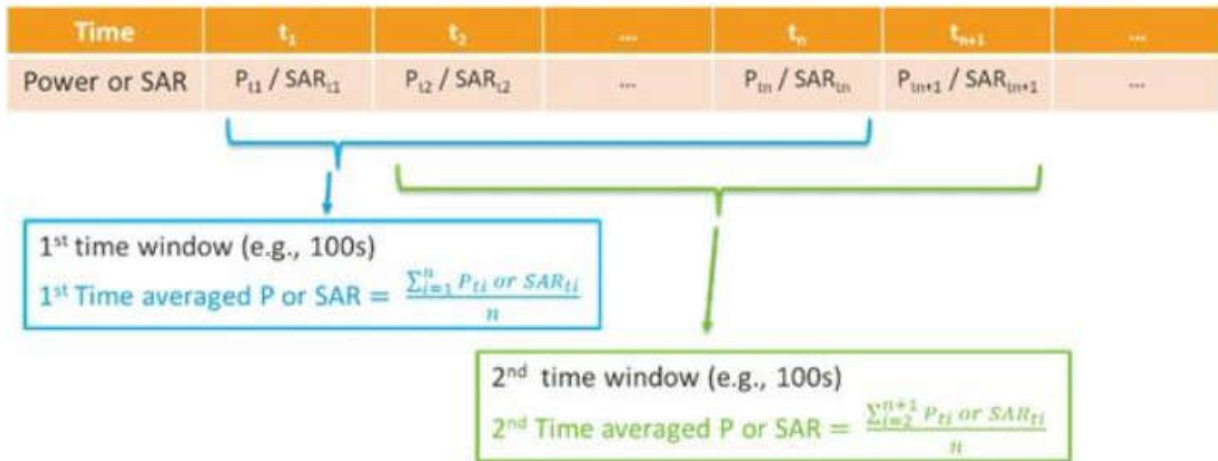

- Step 6: plot results
  - A. Make one power perspective plot containing
    1. Instantaneous TX power
    2. Calculated time-averaged power
    3. Calculated time-averaged power limits
  - B. Make one SAR perspective plot containing
    1. Calculated time-averaged 1gSAR or 10gSAR
    2. FCC limit of 1.6 W/kg (1gSAR) or 4.0 W/kg (10gSAR)



## **4.3 Test Configuration and Procedure for Scenario 2: Time-Varying TX Power via Conducted Power Measurements**

### **4.3.1 Configuration**

Since Mediatek's TA-SAR Gen2 feature operation is independent of bands and channels for a given RAT, selecting one band per RAT is sufficient to validate this feature. Two bands per RAT are proposed for this test. The criteria for band selection for each RAT is based on the  $P_{sub6\_limit}$  values (corresponding to  $SAR\_design\_limit$ ) and is described as below:

- Select two bands, among the ones whose  $P_{sub6\_limit}$  values are below  $P_{UE\_max}$ , which correspond to least and highest  $P_{sub6\_limit}$  values respectively.
  - Only one band needs to be tested if all the bands have same  $P_{sub6\_limit}$ .
  - Only one band needs to be tested if only the band has  $P_{sub6\_limit}$  below  $P_{UE\_max}$ .
  - If the same least  $P_{sub6\_limit}$  applies to multiple bands, select the band with the highest measured 1gSAR at  $P_{sub6\_limit}$ .
  - If  $P_{sub6\_limit}$  values of all bands are all over  $P_{UE\_max}$  (i.e., TA-SAR Gen2 feature is not enabled), there is no need to test this RAT.

### 4.3.2 Procedure

TX power is measured, recorded, and processed by the following steps:

- Step 1~4: measure and record TX power versus time for test scenario 2

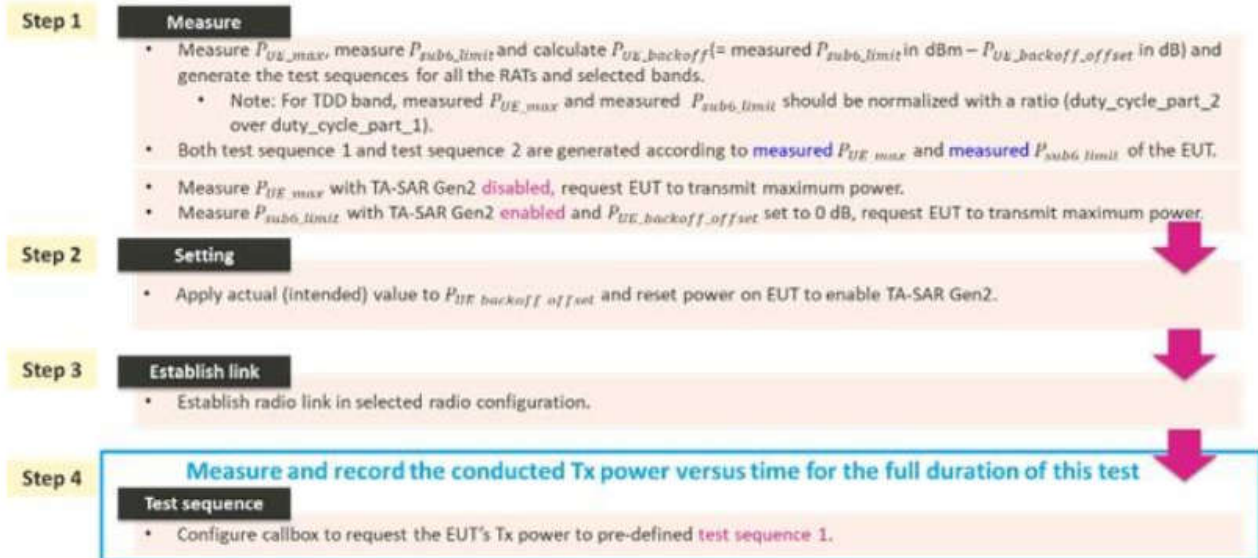

- Step 5: convert the measured conducted TX power into SAR

Convert the measured conducted TX power from step 4 into 1gSAR or 10gSAR value, and perform the running time average on the conducted TX power and 1gSAR or 10g SAR to determine the time-averaged TX power or SAR by using the following equations.

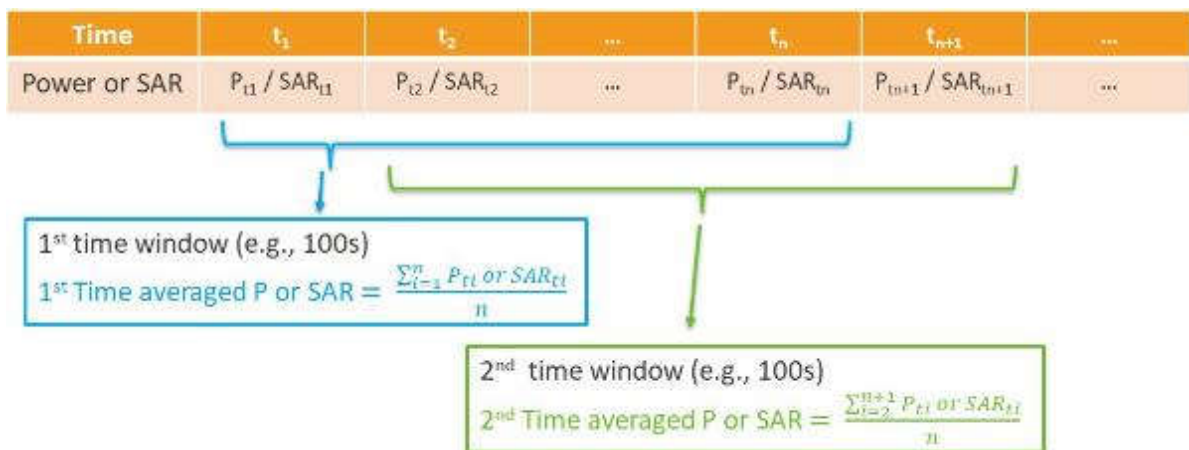

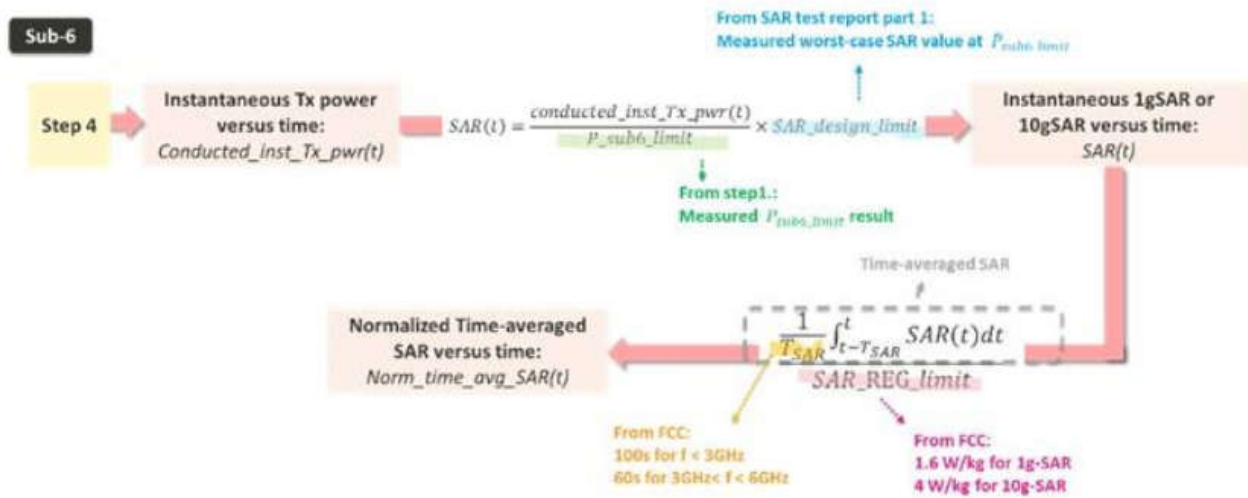

- Step 6: plot results
  - A. Make one power perspective plot containing
    1. Instantaneous TX power
    2. Calculated time-averaged power
    3. Calculated time-averaged power limits
  - B. Make one SAR perspective plot containing
    1. Calculated time-averaged 1gSAR or 10gSAR
    2. FCC limit of 1.6 W/kg (1gSAR) or 4.0 W/kg (10gSAR)

- Step 7: repeat steps 2~6 for test sequence 2

Repeat steps 2 ~ 6 for pre-defined test sequence 2 and replace test sequence 1 in step 4 with test sequence 2.

- Step 8: repeat steps 2~7 for different bands

## 4.4 Test Configuration and Procedure for Scenario 3: Call Disconnection and Re-establishment via Conducted Power Measurements

### 4.4.1 Configuration

For call disconnection measurement, the criteria of selecting the test configuration is:

- Select the RAT/band with least  $P_{sub6\_limit}$  among all supported RATs/bands.
- Select the RAT/band having the highest measured 1gSAR at  $P_{sub6\_limit}$  if multiple RATs/bands having same least  $P_{sub6\_limit}$ .

### 4.4.2 Procedure

TX power is measured, recorded, and processed by the following steps:

- Step 1~4: measure and record TX power versus time for test scenario 3

Measure / setting	
Step 1	<ul style="list-style-type: none"> <li>• Measure <math>P_{sub6\_limit}</math> with TA-SAR Gen2 enabled and <math>P_{UE\_backoff\_offset}</math> set to 0 dB for the selected RAT/band, request EUT to transmit maximum power.               <ul style="list-style-type: none"> <li>• Note: For TDD band, measured <math>P_{UE\_max}</math> and measured <math>P_{sub6\_limit}</math> should be normalized with a ratio (duty_cycle_part_2 over duty_cycle_part_1).</li> </ul> </li> </ul>
Step 2	<ul style="list-style-type: none"> <li>• Apply actual (intended) value to <math>P_{UE\_backoff\_offset}</math> and reset power on EUT to enable TA-SAR Gen2.</li> </ul>
Step 3	<ul style="list-style-type: none"> <li>• Establish radio link in the selected RAT/band with callbox.</li> </ul>
Step 4	<p style="text-align: center;"><b>Measure and record the conducted Tx power versus time for the full duration of this test</b></p> <div style="border: 1px solid black; padding: 5px;"> <p><b>Initial request</b></p> <ul style="list-style-type: none"> <li>• Request EUT's Tx power at 0 dBm for at least one time window specified for the selected RAT/band.</li> <li>• Then request EUT's Tx power to be at maximum power for at least one time window.</li> </ul> <p><b>Drop the call</b></p> <ul style="list-style-type: none"> <li>• Drop the call for ~10 seconds.</li> </ul> <p><b>Re-establish</b></p> <ul style="list-style-type: none"> <li>• Re-establish another call in the same radio configuration as first link (i.e., same RAT/band/channel).</li> <li>• For the remaining time, continue callbox requesting EUT's Tx power to be at maximum power for at least one time window.</li> </ul> </div>

- Step 5: convert the measured conducted TX power into SAR

Convert the measured conducted TX power from step 4 into 1gSAR or 10gSAR value, and perform the running time average on the conducted TX power and 1gSAR or 10g SAR to determine the time-averaged TX power or SAR by using the following equations (also see section 4.2.2 for the illustration of the running time average operation).

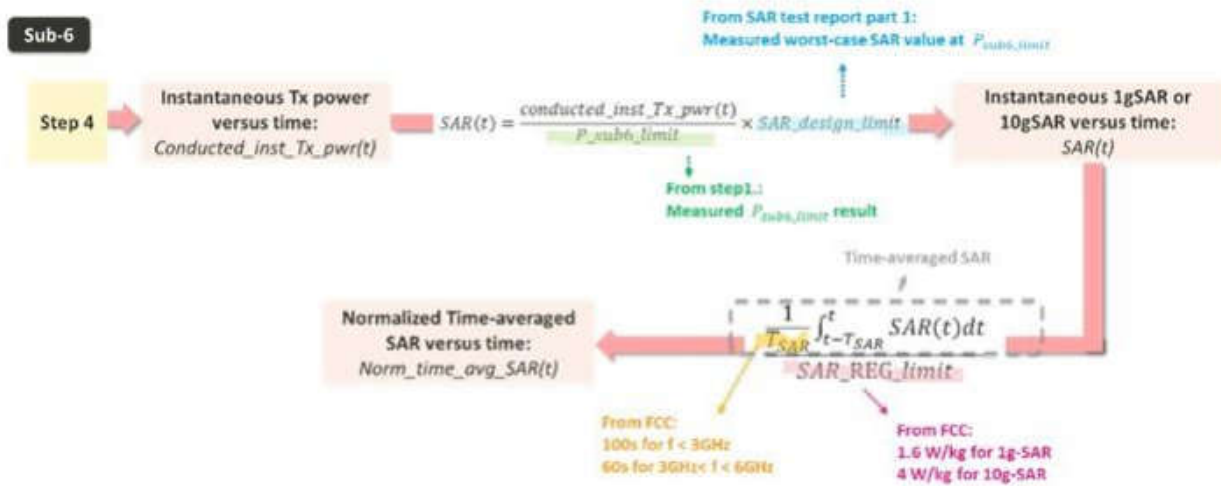

- Step 6: plot results
  - Make one power perspective plot containing
    - Instantaneous TX power
    - Calculated time-averaged power
    - Calculated time-averaged power limits
  - Make one SAR perspective plot containing
    - Calculated time-averaged 1gSAR or 10gSAR
    - FCC limit of 1.6 W/kg (1gSAR) or 4.0 W/kg (10gSAR)

## 4.5 Test Configuration and Procedure for Scenario 4: Band Handover via Conducted Power Measurements

### 4.5.1 Configuration

For a given TX antenna, select a RAT/band with the lowest  $P_{sub6\_limit}$  and the other RAT/band with the highest  $P_{sub6\_limit}$ . Both of them have  $P_{sub6\_limit}$  values less than  $P_{UE\_max}$  if possible.

- Select the RAT/band having the highest measured 1gSAR at  $P_{sub6\_limit}$  if multiple RATs/bands have the same lowest  $P_{sub6\_limit}$ .
- Select the RAT/band having the lowest measured 1gSAR at  $P_{sub6\_limit}$  if multiple RATs/bands have the same highest  $P_{sub6\_limit}$ .

### 4.5.2 Procedure

TX power is measured, recorded, and processed by the following steps:

- Step 1~4: measure and record TX power versus time for test scenario 4

<b>Step 1</b>	<b>Measure / setting</b>	<ul style="list-style-type: none"> <li>• Measure <math>P_{sub6\_limit}</math> for both the selected RATs and bands. Measure <math>P_{sub6\_limit}</math> with TA-SAR Gen2 <b>enabled</b> and <math>P_{UE\_backoff\_offset}</math> set to 0 dB, request EUT to transmit maximum power.             <ul style="list-style-type: none"> <li>• Note: For TDD band, measured <math>P_{UE\_max}</math> and measured <math>P_{sub6\_limit}</math> should be normalized with a ratio (duty_cycle_part_2 over duty_cycle_part_1).</li> </ul> </li> </ul>
<b>Step 2</b>		<ul style="list-style-type: none"> <li>• Apply actual (intended) value to <math>P_{UE\_backoff\_offset}</math> and reset power on EUT to enable TA-SAR Gen2.</li> </ul>
<b>Step 3</b>		<ul style="list-style-type: none"> <li>• Establish radio link in first selected RAT/band with callbox.</li> </ul>
<b>Step 4</b>		<p style="text-align: center; color: #00aaff;"><b>Measure and record the conducted Tx power versus time for the full duration of this test</b></p> <div style="background-color: #333333; color: white; padding: 2px;"><b>Initial request</b></div> <ul style="list-style-type: none"> <li>• Request EUT's Tx power at 0 dBm for at least one time window specified for the selected RAT/band.</li> <li>• Then request EUT's Tx power to be at maximum power for at least one time window.</li> </ul> <div style="text-align: right; color: #cc0000; font-size: 2em;">↓</div> <div style="background-color: #333333; color: white; padding: 2px;"><b>RAT/Band switch</b></div> <ul style="list-style-type: none"> <li>• Switch the radio link to second RAT/band selected.</li> <li>• For the remaining time, continue callbox requesting EUT's Tx power to be at maximum power for at least one time window.</li> </ul>

- Step 5: convert the measured conducted TX power into SAR

Convert the measured conducted TX power from step 4 into 1gSAR or 10gSAR value, and perform the running time average on the conducted TX power and 1gSAR or 10g SAR to determine the time-averaged TX power or SAR by using the following equations (also see section 4.2.2 for the illustration of the running time average operation).

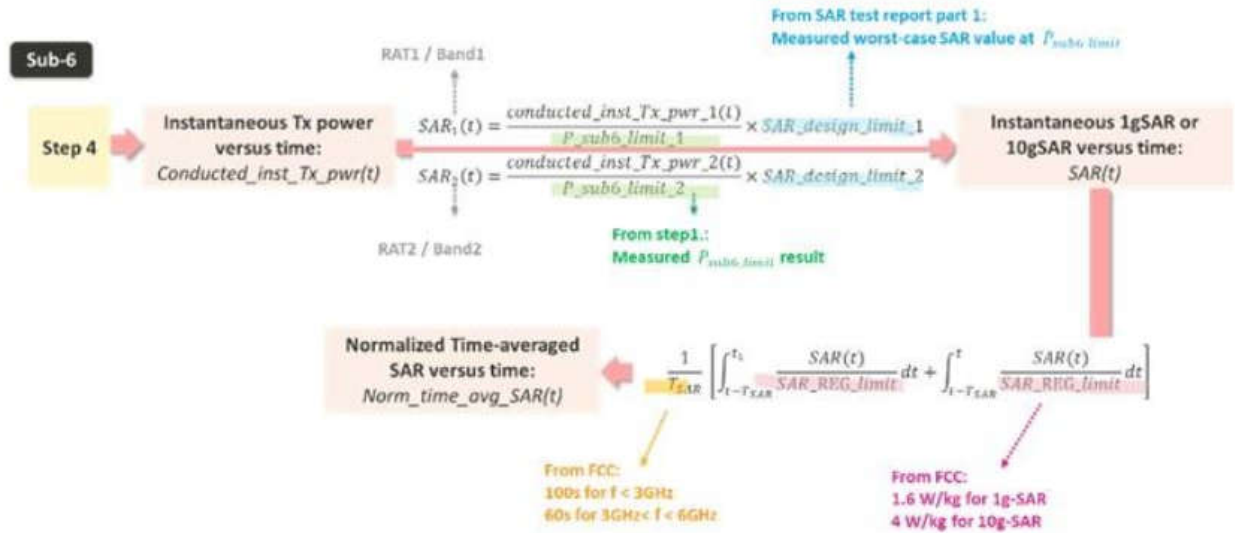

- Step 6: plot results
  - A. Make one power perspective plot containing
    1. Instantaneous TX power
    2. Calculated time-averaged power
    3. Calculated time-averaged power limits
  - B. Make one SAR perspective plot containing
    1. Calculated time-averaged 1gSAR or 10gSAR
    2. FCC limit of 1.6 W/kg (1gSAR) or 4.0 W/kg (10gSAR)
    3. Normalized time-averaged 1gSAR/1.6 or 10gSAR/4.0

## **4.6 Test Configuration and Procedure for Scenario 5: Exposure Condition Index (ECI) Change via Conducted Power Measurements**

### **4.6.1 Configuration**

Select any one RAT/band, which has at least two ECIs whose  $P_{\text{sub6\_limit}}$  values are different and are below  $P_{\text{UE\_max}}$ .

### **4.6.2 Procedure**

The test procedure is identical to section 4.5.2 except the following 2 changes:

1. Replace band switch operation with ECI switch.
2. In Step 4, the second ECI switching is arranged after the first one lasts for at least one time window, i.e., switch the second ECI back to the first ECI, and then continue with callbox requesting EUT's Tx power to be at maximum power for at least one time window.

It is noted that the following operations are done as well for this scenario:

- The correct power control is controlled by TA-SAR Gen2 algorithm during ECI switches from one ECI to another.
- The validation criteria are, at all times, the time-averaged 1gSAR or 10gSAR versus time shall not exceed FCC limit of 1.6 W/kg for 1gSAR or 4.0 W/kg for 10gSAR at all times.

## **4.7 Test Configuration and Procedure for Scenario 6: Antenna Switching via Conducted Power Measurements**

### **4.7.1 Configuration**

Among RATs/bands supporting TX antenna switches, select the RAT/band with the highest  $P_{sub6\_limit}$  difference between a pair of supported TX antennas.

- Select the RAT/band having the highest measured 1gSAR at  $P_{sub6\_limit}$  if multiple RATs/bands having the same  $P_{sub6\_limit}$  difference between the supported TX antennas.
- Antenna selection order
  - Select the configuration with two antennas having  $P_{sub6\_limit}$  values less than  $P_{UE\_max}$ .
  - If the previous configuration does not exist, select the configuration with one antenna having  $P_{sub6\_limit}$  value less than  $P_{UE\_max}$ .
  - If the above two cannot be found, select one configuration with the two antennas having the least difference between their  $P_{sub6\_limit}$  and  $P_{UE\_max}$  (i.e.,  $P_{sub6\_limit}$  can be greater than  $P_{UE\_max}$ ).

### **4.7.2 Procedure**

The test procedure is identical to section 4.5.2 except the following 2 changes:

1. Replace band switch operation with antenna switch.
2. In Step 4, the second antenna switching is arranged after the first one lasts for at least one time window, i.e., switch the second antenna back to the first antenna, and then continue with callbox requesting EUT's Tx power to be at maximum power for at least one time window.

It is noted that the following operations are done as well for this scenario:

- The correct power control is controlled by TA-SAR Gen2 algorithm during antenna switches from one antenna to another.
- The validation criteria are, at all times, the time-averaged 1gSAR or 10gSAR versus time shall not exceed FCC limit of 1.6 W/kg for 1gSAR or 4.0 W/kg for 10gSAR at all times.

## 4.8 Test Configuration and Procedure for Scenario 7: Time Window Switching via Conducted Power Measurements

### 4.8.1 Configuration

Select one RAT/band with 60-second time averaging window, and the other RAT/band with 100-second time averaging window. Both of them have  $P_{sub6\_limit}$  values less than  $P_{UE\_max}$  if possible.

- At least one of the selected RAT/band has its  $P_{sub6\_limit}$  less than  $P_{UE\_max}$ .

### 4.8.2 Procedure

TX power is measured, recorded, and processed by the following steps:

- Step 1~4: measure and record TX power versus time for test scenario 7

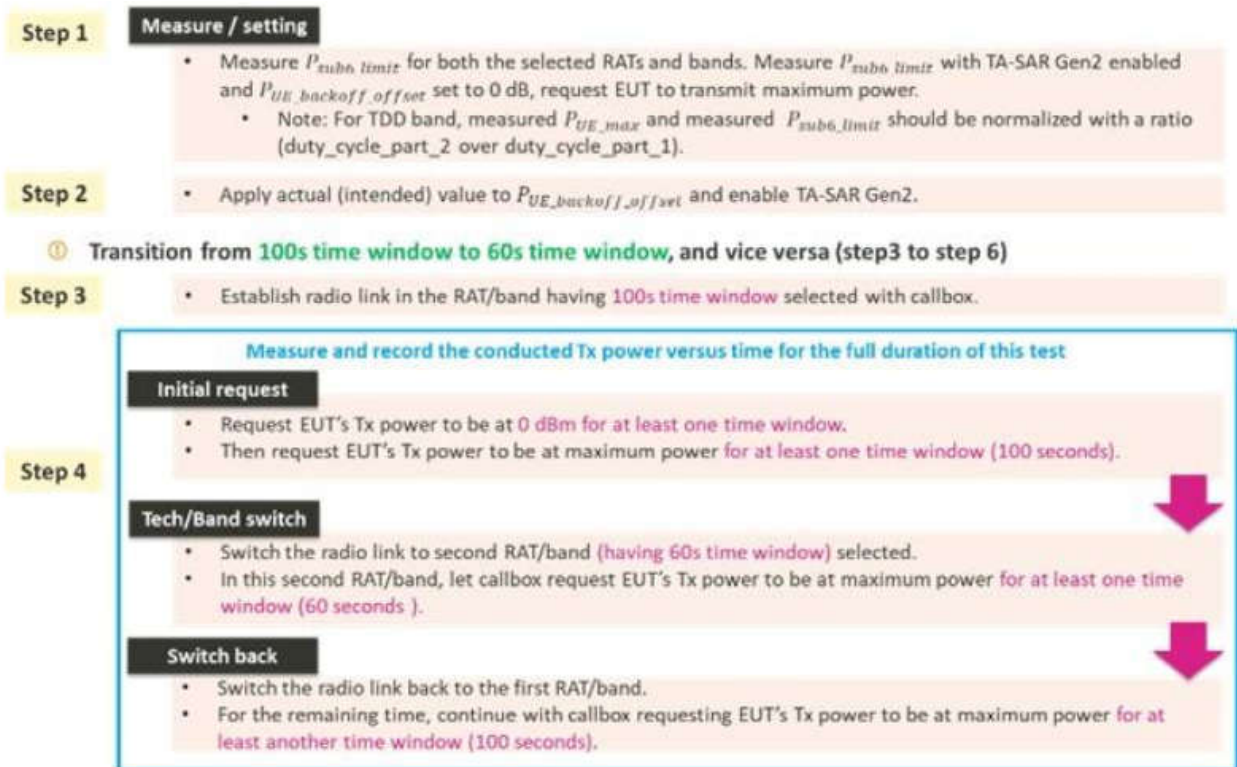

- Step 5: convert the measured conducted TX power into SAR

Convert the measured conducted TX power from step 4 into 1gSAR or 10gSAR value, and perform the running time average on the conducted TX power and 1gSAR or 10g SAR to determine the time-averaged TX power or SAR by using the following equations (also see section 4.2.2 for the illustration of the running time average operation).

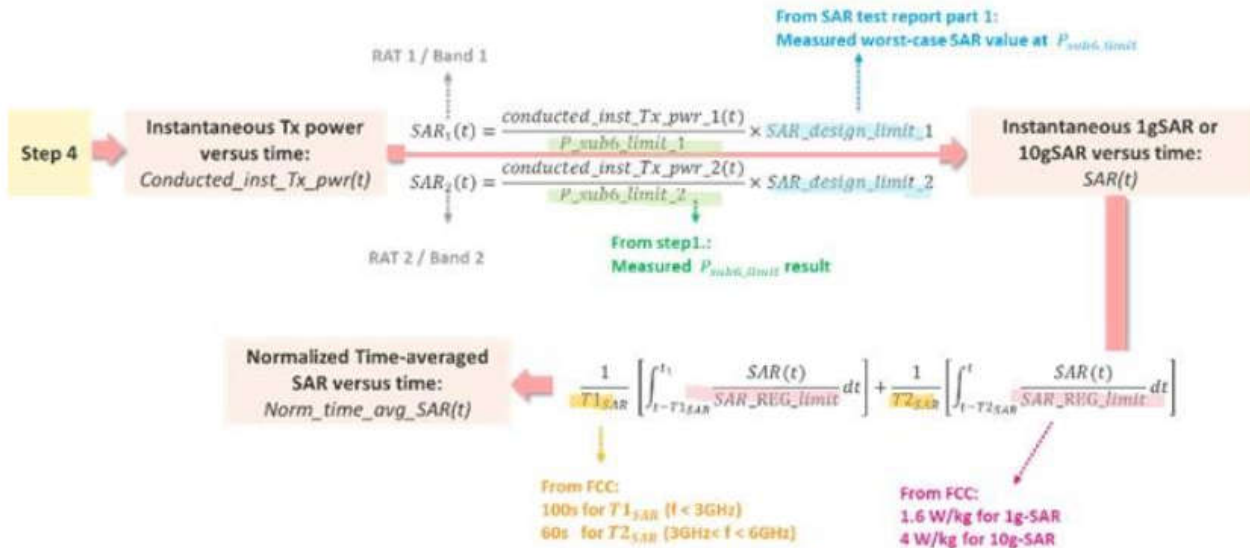

- Step 6: plot results
  - A. Make one power perspective plot containing
    1. Instantaneous TX power
    2. Calculated time-averaged power
    3. Calculated time-averaged power limits
  - B. Make one SAR perspective plot containing
    1. Calculated time-averaged 1gSAR or 10gSAR
    2. FCC limit of 1.6 W/kg (1gSAR) or 4.0 W/kg (10gSAR)
    3. Normalized time-averaged 1gSAR/1.6 or 10gSAR/4.0

- Step 7~8: measure and record TX power versus time in another time window change

② Transition from 60s time window to 100s time window, and vice versa (step7 to step 9)

Step 7

- Establish radio link with callbox in the RAT/band having 60s time window selected.

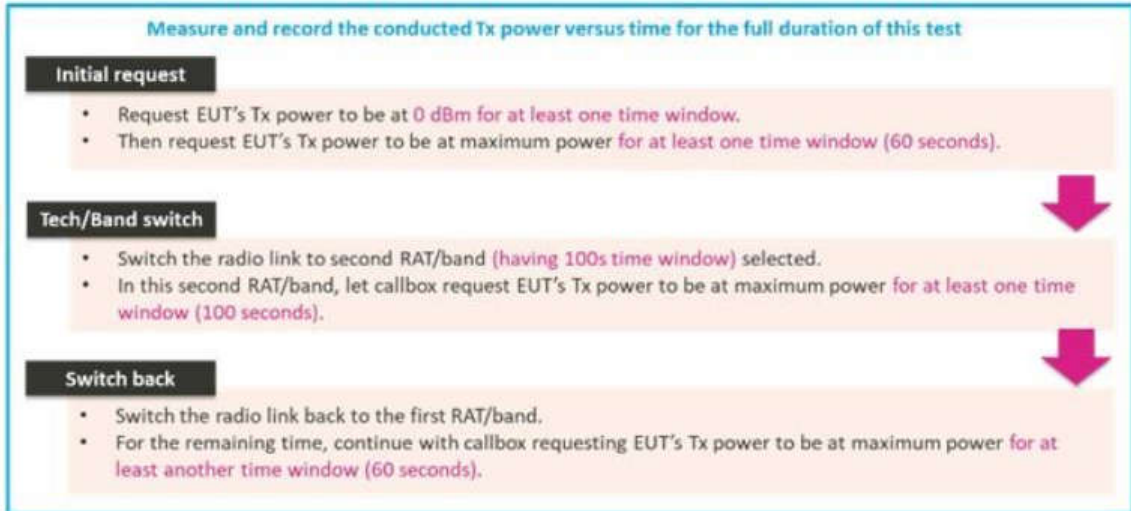

- Step 9: convert the measurement and plot results

Convert the measured conducted TX power from step 8 into 1gSAR or 10gSAR value using the equation in step 5.

Repeat step 6 to generate the plots.

## **4.9 Test Configuration and Procedure for Scenario 8: SAR Exposure Switching via Conducted Power Measurements**

### **4.9.1 Configuration**

If supported, SAR exposure switch with two active radio sets having the same and different time averaging windows should be covered in this test. Since the algorithm is independent of SPLSR groups, it is sufficient to select a SPLSR group to validate the algorithm. Note that a radio set contains one or more than one radio, and each radio would use one or two antennas. The TA-SAR Gen2 algorithm operation is independent of the source of SAR exposure (e.g., LTE vs. NR FR1) and ensures total time-averaged RF exposure compliance for SAR exposure among the scenarios of radio set 1 only, radio set 1 + radio set 2, and radio set 2 only.

- For a radio set, select one or two sub6 RATs/bands that the EUT supports for simultaneous transmission (e.g., LTE+NR FR1).
- The selection order among all supported simultaneous transmission configurations is
  - For each radio set, select one configuration of each radio (either with one antenna or two antennas) with  $P_{sub6\_limit}$  values less than the corresponding  $P_{UE\_max}$ . If a radio has two antennas, their  $P_{sub6\_limit}$  values are different if possible.
  - If the previous configuration does not exist, at least one radio set, between the active two radio sets, has one radio which has one antenna with  $P_{sub6\_limit}$  less than  $P_{UE\_max}$ .
  - If above two cannot be found, select the configurations in radio sets 1 and 2 that have  $P_{sub6\_limit}$  with the least difference between  $P_{sub6\_limit}$  and  $P_{UE\_max}$  (i.e.,  $P_{sub6\_limit}$  can be greater than  $P_{UE\_max}$ )
  -
- One test with two active radios in the same SPLSR groups is sufficient to cover this scenario.
- One SAR switching is sufficient because the TA-SAR Gen2 algorithm operation is the same.

### 4.9.2 Procedure

- Step 1~3: measure and record TX power versus time for test scenario 8
- Step 1.A. Measure conducted TX power corresponding to radio set 1 ( $P_{sub6\_limit}$ )
  - Establish device in call with the callbox for set 1 RAT/band.
  - Measure conducted TX power corresponding to each radio in radio set 1 ( $P_{sub6\_limit}$ ) with TA-SAR Gen2 algorithm enabled and  $P_{UE\_backoff\_offset}$  set to 0 dB, callbox set to request maximum power.
  - If one radio is dependent on the other radio(s) (for example, non-standalone mode of Sub6 NR requiring LTE as anchor), then establish the connections of both radios with the callbox. Request the target radio to transmit maximum power and the other radio(s) at low power (e.g., all-down bits), and measure conducted TX power corresponding to  $P_{sub6\_limit}$ .

Step 1.B. measure conducted TX power corresponding to each radio in radio set 2 ( $P_{sub6\_limit}$ )

- Repeat above step to measure conducted TX power corresponding to each radio in radio set 2 ( $P_{sub6\_limit}$ )

NOTE: if a radio set contains more than one radio, or use more than one antenna, measure each active antenna's  $P_{sub6\_limit}$ .

<b>Step 1</b>	<b>Measure / setting</b>	<ul style="list-style-type: none"> <li>Measure conducted Tx power corresponding to each radio in radio set 1 and radio set 2.</li> <li>Test condition to measure conducted <math>P_{sub6\_limit}</math> is in <b>step 1.A and 1.B.</b> <ul style="list-style-type: none"> <li>Note: For TDD band, measured <math>P_{UE\_max}</math> and measured <math>P_{sub6\_limit}</math> should be normalized with a ratio (duty_cycle_part_2 over duty_cycle_part_1).</li> </ul> </li> <li>Apply actual (intended) value to <math>P_{UE\_backoff\_offset}</math> corresponding to each radio in radio set 1 and radio set 2 with EUT setup for radio set 1 + radio set 2 connection and enable TA-SAR Gen2.</li> <li>(In this description, it is assumed that radio set 2 has lower priority than radio set 1)</li> </ul>
<b>Step 2</b>	<b>Establish link</b>	<ul style="list-style-type: none"> <li>Establish device in radio set 1+radio set 2 connection, and request low power (e.g., all-down bits) on radio set 1.</li> </ul>
<b>Step 3</b>	<p style="text-align: center; color: #00aaff; font-weight: bold;">Measure and record the conducted Tx power for both radio set 1 and radio set 2 for the full duration of this test</p> <div style="background-color: #333; color: white; padding: 2px;"><b>Radio set 2 predominant</b></div> <ul style="list-style-type: none"> <li>Let callbox request EUT's Tx power to be at 0 dBm in radio set 2 for at least one time window.</li> <li>Then let callbox request EUT's Tx power to be at maximum power in radio set 2 for at least one time window.</li> </ul> <div style="background-color: #333; color: white; padding: 2px; text-align: center;"><b>Radio set 1+2</b></div> <ul style="list-style-type: none"> <li>set callbox to request EUT's Tx power to be at maximum power on radio set 1, i.e., all-up bits.</li> <li>Continue radio set 1+radio set 2 call with both radios at maximum power for at least one time window.</li> </ul> <div style="background-color: #333; color: white; padding: 2px;"><b>Radio set 1 predominant</b></div> <ul style="list-style-type: none"> <li>drop (or request all-down bits on) radio set 2.</li> <li>Continue radio set 1 at maximum power for at least one time window.</li> </ul>	

- Step 4: convert the measured conducted TX power into SAR

Convert the measured conducted TX power from step 3 into 1gSAR or 10gSAR value, and perform the running time average on the conducted TX power and 1gSAR or 10g SAR to determine the time-averaged TX power or SAR by using the following equations (also see section 4.2.2 for the illustration of the running time average operation).

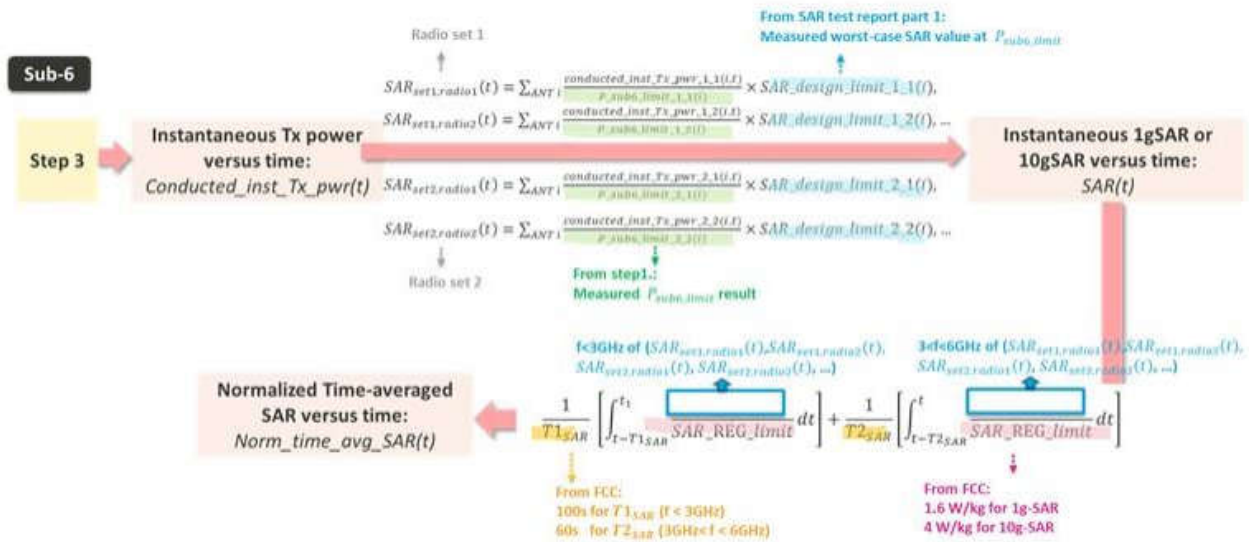

NOTE: A SAR set ( $SAR_{set}$ ) contains one or more than one radio, and each SAR set would use one or two antennas. Please note that time-averaged SAR calculation needs to consider the frequency sort of the instantaneous SAR.

- Step 5: plot results
  - Make one power perspective plot containing
    - Instantaneous TX power
    - Calculated time-averaged power
    - Calculated time-averaged power limits
  - Make one SAR perspective plot containing
    - Calculated time-averaged 1gSAR or 10gSAR
    - FCC limit of 1.6 W/kg (1gSAR) or 4.0 W/kg (10gSAR)
    - Normalized time-averaged 1gSAR/1.6 or 10gSAR/4.0

## 4.10 Test Configuration and Procedure for Scenario 2: Time-Varying TX Power via SAR Measurements

### 4.10.1 Configuration

Sections 4.2 to 4.9 focus on Mediatek’s TA-SAR Gen2 algorithm compliance validation via conducted TX power measurements. This section further provides a SAR measurement procedure for time-varying TX power scenario described in section 4.3. Hence, this section follows the test configuration of section 4.3, and uses test sequences 1 and 2 defined in section 4.1.

### 4.10.2 Procedure

SAR is measured and recorded by the following steps:

- Step 1~4: measure and record SAR versus time

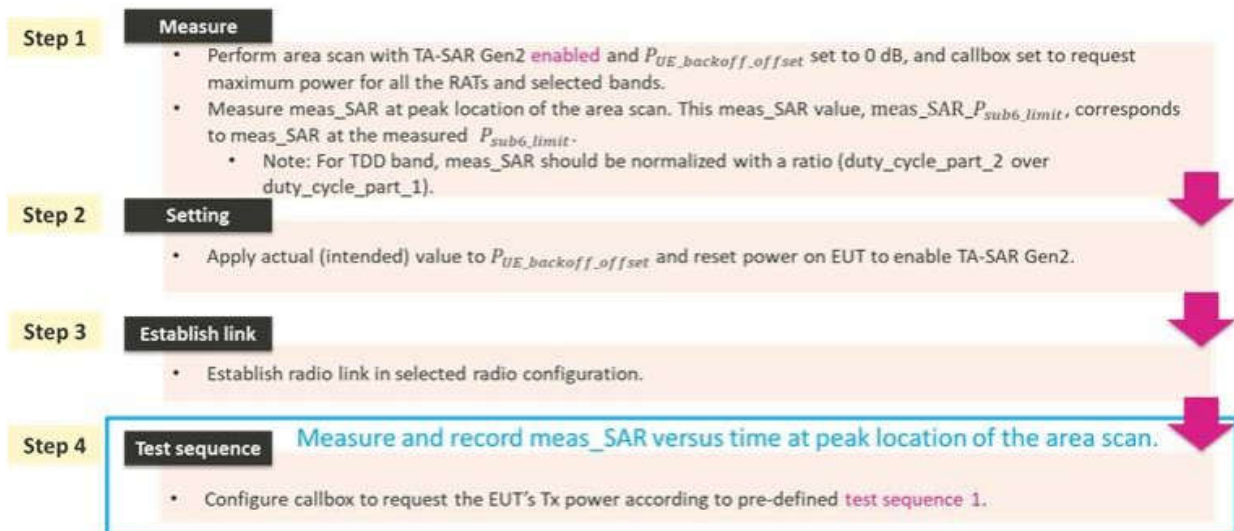

- Step 5: convert the measured SAR into time-averaged SAR

Convert the instantaneous measured SAR from step 4 into 1gSAR or 10gSAR value, and perform the running time average on the instantaneous 1gSAR or 10g SAR to determine time-averaged SAR with the following equations, where,  $meas\_SAR\_P_{sub6\_limit}$  is the value determined in step 1, and  $meas\_SAR(t)$  is the instantaneous measured SAR measured in step 4.

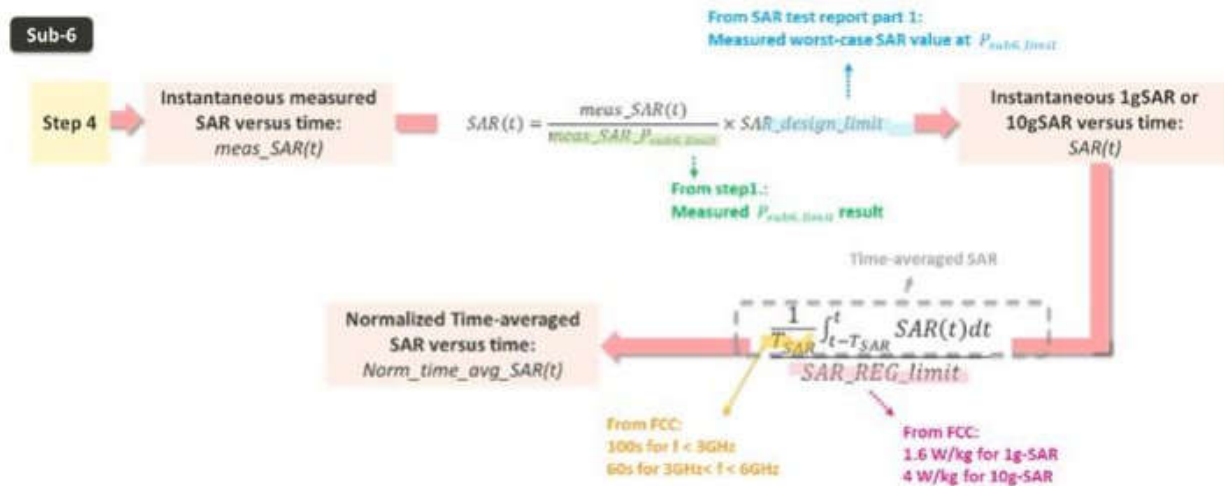

- Step 6: plot result
  - A. Calculated time-averaged 1gSAR or 10gSAR
  - B. FCC limit of 1.6 W/kg (1gSAR) or 4.0 W/kg (10gSAR)

- Step 7: repeat steps 2 ~ 6 for pre-defined test sequence 2

Repeat steps 2 ~ 6 for pre-defined test sequence 2 and replace test sequence 1 in step 4 with test sequence 2.

- Step 8: repeat steps 2 ~ 7 for all the selected bands

The time-averaged SAR versus time shall not exceed FCC limit at all times.

## 5. TA-SAR Gen2 Validation via Conducted Power Measurements

### 5.1 Measurement Setup

#### 5.1.1 Test Bench Introduction

The call boxes Keysight UXM (supporting sub6 NR and LTE) and Rohde & Schwarz CMW500 (supporting LTE, WCDMA, C2K and 2G) are used to validate the proposed TA-SAR Gen2 algorithm. Figure 6-1 shows the block diagram of the measurement bench, which supports the following test scenarios.

- Test scenario 1: range of TA-SAR Gen2 parameters
- Test scenario 2: time-varying TX power
- Test scenario 3: call disconnection and re-establishment
- Test scenario 5: ECI change

For these measurements, RF port of the call box is connected to the EUT's antenna port, and the call box establishes a connection link through the test script console tool and the power meter measures the conducted output power of the EUT.

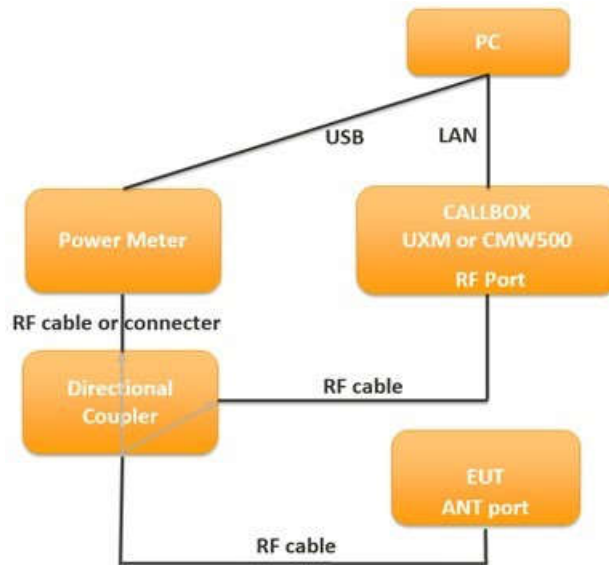
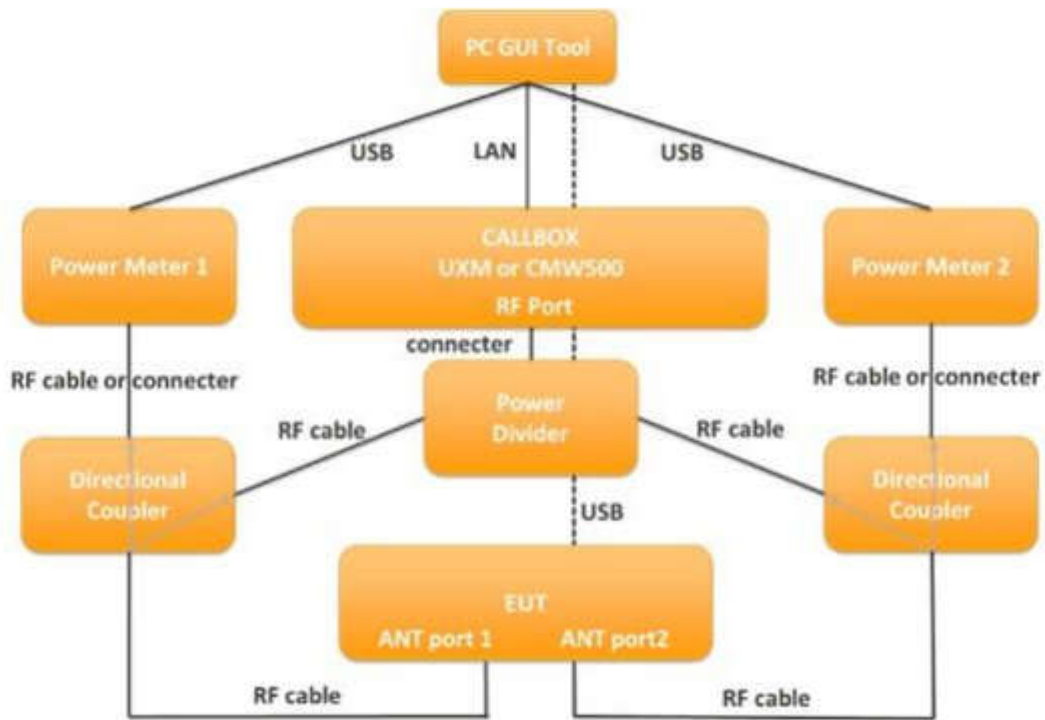

Figure 6- 1 TA-SAR Gen2 conductive power test setup block diagram for scenarios 1/2/3/5

Figure 6-2 shows the block diagram of the measurement bench, which support test scenario 6 (antenna switching) and scenario 7 (time window switching). For these measurements, the RF port of the call box is connected with a 1-to-2 power divider and two EUT's antenna ports are individually connected with a RF cable, which allows the call box to transmit/receive signals from the two different system configurations set in these two test scenarios, as seen in the figure.



**Figure 6- 2 TA-SAR Gen2 conductive power test setup block diagram for scenarios 6/7**

Figure 6-3 shows the setup for test scenario 4 (band handover) with different RATs and test scenario 8 (SAR exposure switching). Since two RATs/bands need to be controlled in these two scenarios, RF port of RAT/band #1 and RF port of RAT/band #2 of the call box are individually connected to an antenna port of the EUT through a directional coupler. It is noted that each of the two RATs/bands individually transmit signals though one antenna port. The antenna port assignment of each RAT/band for these two scenarios is described in Antenna position with Appendix D of Part 1.

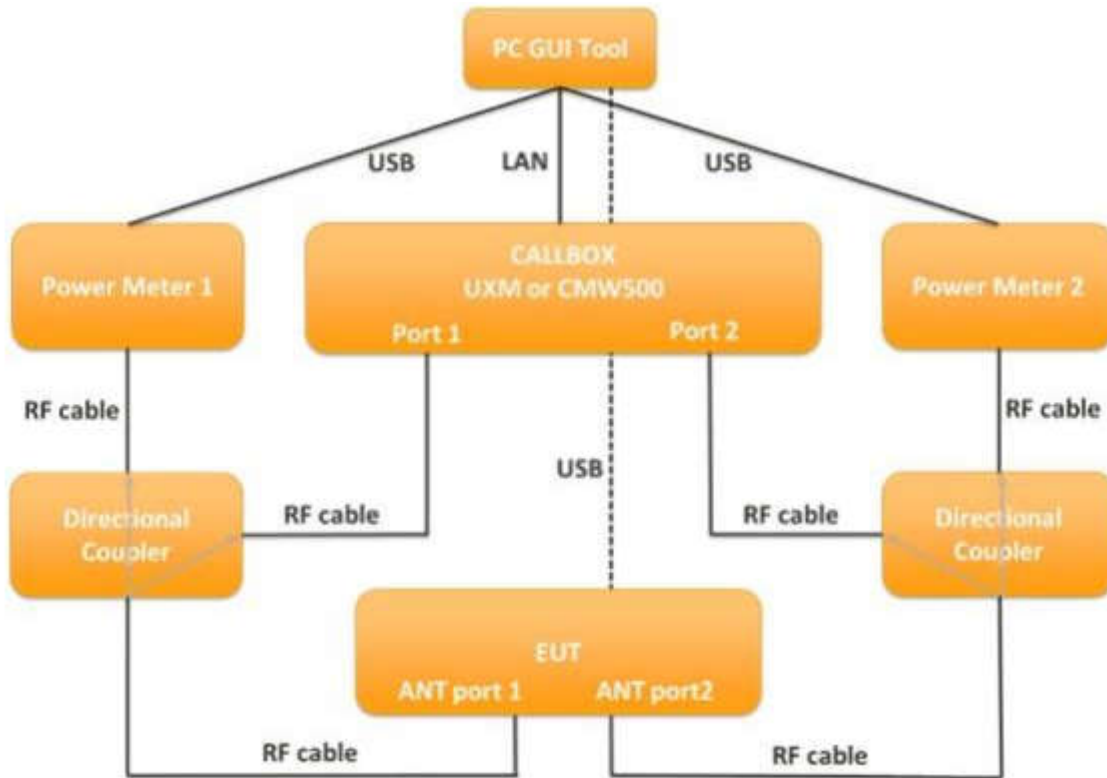

Figure 6- 3 TA-SAR Gen2 conductive power test setup block diagram for scenarios 4/8



### 5.1.2 Sub6 NR/LTE/3G/2G Power Limit Table and Test Configurations

For the supported bands/channels/antennas of each technology, the measured power limit ( $P_{sub6\_limit}$ ), corresponding to  $SAR\_design\_limit$ , is listed in the table 6-1. The  $SAR\_design\_limit$  is determined by taking +1dB device uncertainty into consideration. Please note that for TDD bands with TX duty cycles less than or equal to 100%, the measured power limit corresponds to the burst averaged power level which does not account for TX duty cycle.

**Table 6-1 Summary table of power limit ( $P_{sub6\_limit}$ ) for all supported RAT**

Band	Antenna	ECI 2	ECI 3	ECI 4	ECI 7	ECI 10	ECI 11	ECI 12	ECI 13	Pmax*
GSM850	Ant 0	23.5	23.0	25.5	23.0	26.1				25.5
GSM1900	Ant 0	33.3	19.0	22.5	17.5	21.5				22.5
WCDMA II	Ant 0	32.3	17.5	23.0	16.0	20.5				23.0
WCDMA IV	Ant 0	29.2	18.5	23.0	17.5	21.5				23.0
WCDMA V	Ant 0	26.7	21.0	23.0	21.0	23.4				23.0
LTE Band 2	Ant 0	26.9	17.5	23.0	16.0	20.0				23.0
LTE Band 2	Ant 4	15.5	16.0	23.0	13.0			19.0		23.0
LTE Band 4	Ant 0	29.8	18.0	23.0	17.0	21.0				23.0
LTE Band 4	Ant 4	14.5	16.0	23.0	13.0			18.0		23.0
LTE Band 5	Ant 0	27.2	21.0	23.0	21.0	26.3				23.0
LTE Band 5	Ant 4	21.2	22.2	23.0	20.2			23.0		23.0
LTE Band 7	Ant 1	27.0	18.5	23.0	18.5		21.0			23.0
LTE Band 7	Ant 4	28.1	28.0	23.0	23.9			23.0		23.0
LTE Band 12	Ant 0	29.5	24.6	23.0	24.6	23.0				23.0
LTE Band 12	Ant 4	22.2	22.7	23.0	21.2			23.0		23.0
LTE Band 13	Ant 0	27.9	23.0	23.0	23.0	26.5				23.0
LTE Band 13	Ant 4	21.2	22.7	23.0	21.2			23.0		23.0
LTE Band 14	Ant 0	28.2	23.0	23.0	23.0	23.0				23.0
LTE Band 14	Ant 4	20.7	22.2	23.0	20.7			23.0		23.0
LTE Band 17	Ant 0	29.5	24.6	23.0	24.6	23.0				23.0
LTE Band 17	Ant 4	22.2	22.7	23.0	21.2			23.0		23.0
LTE Band 25	Ant 0	26.9	17.5	23.0	16.0	20.0				23.0
LTE Band 25	Ant 4	15.5	16.0	23.0	13.0			19.0		23.0
LTE Band 26	Ant 0	27.2	21.0	23.0	21.0	26.3				23.0
LTE Band 26	Ant 4	21.2	22.2	23.0	20.2			23.0		23.0
LTE Band 30	Ant 1	31.3	18.0	23.0	18.0		20.0			23.0
LTE Band 30	Ant 4	25.7	24.9	23.0	21.5			23.0		23.0
LTE Band 38	Ant 1	26.2	18.4	21.0	18.4		20.9			21.0
LTE Band 41 PC3	Ant 1	26.2	18.4	22.4	18.4		20.9			21.0
LTE Band 41 PC2	Ant 1									22.4
LTE Band 48	Ant 5	14.5	14.0	21.0	13.0				19.5	21.0
LTE Band 66	Ant 0	29.8	18.0	23.0	17.0	21.0				23.0
LTE Band 66	Ant 4	14.5	16.0	23.0	13.0			18.0		23.0
LTE Band 71	Ant 0	29.9	26.4	23.0	26.4	23.0				23.0
LTE Band 71	Ant 4	25.1	24.2	23.0	23.0			23.0		23.0
n2	Ant 0	33.7	17.5	23.0	16.5	21.0				23.0
n2	Ant 4	14.0	18.0	23.0	15.0			20.5		23.0
n5	Ant 0	28.7	21.5	23.0	21.5	26.5				23.0
n5	Ant 4	20.5	22.0	23.0	20.5			23.0		23.0
n7	Ant 1	30.2	20.0	23.0	20.0		21.5			23.0
n12	Ant 0	31.0	26.2	23.0	26.2	23.0				23.0
n12	Ant 4	22.0	22.0	23.0	20.5			23.0		23.0
n14	Ant 0	30.2	24.3	23.0	24.3	23.0				23.0
n14	Ant 4	21.0	22.0	23.0	20.5			23.0		23.0



n25	Ant 0	33.7	17.5	23.0	16.5	21.0				23.0
n25	Ant 4	14.0	18.0	23.0	15.0			20.5		23.0
n26	Ant 0	28.7	21.5	23.0	21.5	26.5				23.0
n26	Ant 4	20.5	22.0	23.0	20.5			23.0		23.0
n30	Ant 1	33.0	19.0	23.0	19.0		21.0			23.0
n41 PC3	Ant 1	26.0	18.5	26.0	18.5		21.0			23.0
n41 PC2	Ant 1									26.0
n41 PC3	Ant 4	16.0	15.5	26.0	12.5			21.0		23.0
n41 PC2	Ant 4									26.0
n41 PC3	Ant 2	28.4	16.0	20.0	14.5					23.0
n41 PC2	Ant 2									26.0
n41 PC3	Ant 7	17.5	14.5	20.0	13.0					23.0
n41 PC2	Ant 7									26.0
n48	Ant 5	14.5	14.5	23.0	13.0				19.0	23.0
n66	Ant 0	29.7	18.0	23.0	17.5	21.5				23.0
n66	Ant 4	15.5	19.0	23.0	15.5			21.5		23.0
n70	Ant 0	31.1	18.0	23.0	17.5	21.5				23.0
n70	Ant 4	15.5	19.0	23.0	15.5			21.5		23.0
n71	Ant 0	31.3	27.5	23.0	27.5	23.0				23.0
n71	Ant 4	26.2	25.5	23.0	23.9			23.0		23.0
n77 PC3	Ant 5	15.0	14.5	26.0	13.0				19.5	23.0
n77 PC2	Ant 5									26.0
n77 PC3	Ant 1	36.7	23.5	25.5	23.5		25.5			23.0
n77 PC2	Ant 1									25.5
n77 PC3	Ant 2	32.1	16.5	19.0	15.0					23.0
n77 PC2	Ant 2									26.0
n77 PC3	Ant 8	27.3	17.5	20.5	15.0					23.0
n77 PC2	Ant 8									26.0
n78 PC3	Ant 5	15.0	14.0	26.0	12.5				19.5	23.0
n78 PC2	Ant 5									26.0
n78 PC3	Ant 1	36.7	23.5	25.5	23.5		25.5			23.0
n78 PC2	Ant 1									25.5
n78 PC3	Ant 2	32.1	16.5	19.0	15.0					23.0
n78 PC2	Ant 2									26.0
n78 PC3	Ant 8	27.3	17.5	20.5	15.0					23.0
n78 PC2	Ant 8									26.0

**SPLSR\_Group (Antenna Group):**

Antenna Group 0 (AG0)	ANT0 & ANT1
Antenna Group 1 (AG1)	ANT2 & ANT4 & ANT5 & ANT7 & ANT8

Mediatek developed the TA-SAR Gen2 algorithm to control instantaneous TX power for transmit frequencies less and larger than 6GHz respectively, so that the total time-averaged RF exposures are less than FCC requirement.

TA-SAR Gen2 algorithm validation has been performed for 2G, 3G, LTE, NR FR1 according to cases with different combinations of operating parameters listed in Table 2-1.

**Table 2-1 TA-SAR Gen2 operating parameters**

Operating parameters	Description
$P_{sub6\_limit}$	The time-averaged maximum power level limit for different bands for 2G, 3G, LTE, and NR FR1.
$P_{LowThresh\_offset}$	To calculate $P_{LowThresh}$ . ( $P_{LowThresh} = P_{sub6\_limit} - P_{LowThresh\_offset}$ )
$P_{UE\_backoff\_offset}$	To calculate $P_{UE\_backoff}$ . ( $P_{UE\_backoff} = P_{sub6\_limit} - P_{UE\_backoff\_offset}$ )
$P_{UE\_max\_cust\_offset}$	To calculate $P_{UE\_max\_cust}$ . $P_{UE\_max}$ is maximum TX power at which a UE can possibly transmit. $P_{UE\_max\_cust} = \min(P_{UE\_max}, P_{sub6\_limit} + P_{UE\_max\_cust\_offset})$
$SPLSR\_group$	Sub6 antenna group index
$Level\_num_{sub6\_pwr}$	The number of backoff levels constraining sub6 instantaneous TX power.
$Algo\_avg\_window_{sub6}$	The time-averaged window used by TA-SAR Gen2 algorithm.

**Table for Sub-6GHz TA-SAR validation test case list**

Test Case #	Test Scenario	Test Configuration
1	1.Range of TA-SAR parameters	FR1 n41
2	2.Time-varying TX power	GSM850
3		GSM1900
4		WCDMA V
5		WCDMA II
6		LTE Band 26
7		LTE Band 66
8		FR1 n26
9		FR1 n41
10		3.Call disconnection and re-establishment
11	4. Band handover / 6. Antenna Switch	LTE Band 48 Ant5 to FR1 n41 Ant 4
12	5. ECI (Exposure Condition Index)	FR1 n41 ECI 7 to ECI 3
13	7.Time window switching 60s-100s-60s	LTE B48 to LTE B25
14	7.Time window switching 100s-60s-100s	LTE B25 to LTE B48
15	8.SAR exposure switching (ENDC 100s/100s)	LTE B30 to FR1 n2
16	8.SAR exposure switching (ENDC 100s/60s)	LTE B5 to FR1 n77



Table 6-2 summarizes the test configurations of all RATs, and the corresponding worst-case measured SAR for each RAT under the power limit.

**Table 6-2 Test configurations of radio technologies and worst-case measured SAR**

Test case #	Test scenario	Tech	Band	Ant	SPLSR Group	ECI	Channel	Freq (MHz)	BW	RB size	RB offset	Mode	Duty cycle	Position	Position details	Part 1 worst-case radio config 1g measured @Plimit (W/kg)
1	Range of TA-SAR parameters	5G NR	n41	4	1	7	518598	2592.99	100	1	1	DFT-30,QPSK	100.0%	Top Side	5mm	0.286
2	Time-varying TX power	GSM	850	0	0	3	189	836.4	-	-	-	GPRS (4 Tx slots)	50.0%	Back	5mm	0.913
3		GSM	1900	0	0	3	810	1909.8	-	-	-	GPRS (4 Tx slots)	50.0%	Back	5mm	0.967
4		WCDMA	5	0	0	3	4233	846.6	-	-	-	RMC 12.2Kbps	100.0%	Back	5mm	0.780
5		WCDMA	2	0	0	3	9538	1907.6	-	-	-	RMC 12.2Kbps	100.0%	Back	5mm	0.858
6		LTE	26	4	1	3	26965	841.5	15	1	0	QPSK	100.0%	Back	5mm	0.635
7		LTE	66	4	1	7	132322	1745	20	1	0	QPSK	100.0%	Top Side	5mm	0.213
8		5G NR	n26	4	1	3	166300	831.5	20	50	28	DFT-15,QPSK	100.0%	Back	5mm	0.564
9		5G NR	n41	4	1	7	518598	2592.99	100	1	1	DFT-30,QPSK	100.0%	Top Side	5mm	0.286
10		Call disconnection and re-establishment	5G NR	n41	4	1	7	518598	2592.99	100	1	1	DFT-30,QPSK	100.0%	Top Side	5mm
11	Band handover	LTE	48	5	1	7	56150	3641	20	1	0	QPSK	63.3%	Back	5mm	0.307
		5G NR	n41	4	1	7	518598	2592.99	100	1	1	DFT-30,QPSK	100.0%	Top Side	5mm	0.286
12	Change in operating state	5G NR	n41	4	1	7	518598	2592.99	100	1	1	DFT-30,QPSK	100.0%	Top Side	5mm	0.286
		5G NR	n41	4	1	3	518598	2592.99	100	1	1	DFT-30,QPSK	100.0%	Back	5mm	0.577
13	Time window switching (60s-100s-60s)	LTE	48	5	1	7	56150	3641	20	1	0	QPSK	63.3%	Back	5mm	0.307
		LTE	25	4	1	7	26340	1880	20	1	0	QPSK	100.0%	Top Side	5mm	0.260
14	Time window switching (100s-60s-100s)	LTE	25	4	1	7	26340	1880	20	1	0	QPSK	100.0%	Top Side	5mm	0.260
		LTE	48	5	1	7	56150	3641	20	1	0	QPSK	63.3%	Back	5mm	0.307
15	SAR exposure switching (ENDC 100s/100s)	LTE	30	1	0	7	27710	2310	10	1	0	QPSK	100.0%	Back	5mm	0.618
		5G NR	n2	0	0	7	376000	1880	20	1	1	DFT-15,QPSK	100.0%	Bottom Side	5mm	0.809
16	SAR exposure switching (ENDC 100s/60s)	LTE	5	4	1	7	20525	836.5	10	1	0	QPSK	100.0%	Back	5mm	0.351
		5G NR	n77	2	1	7	633332	3499.98	100	1	1	DFT-30,QPSK	100.0%	Back	5mm	0.154



Table 6-3 Test configurations of radio technologies and worst-case measured Plimit and Pmax

Test case #	Test scenario	Tech	Band	Ant	SPLSR Group	ECI	Channel	Freq (MHz)	BW	RB size	RB offset	Mode	Duty cycle	Position	Position details	Plimit Setting (dBm)	Target Pmax (dBm)	Measured Plimit (dBm)	Measured Pmax (dBm)	PUE_max_cust_offset	PUE_Backoff_offset
1	Range of TA-SAR parameters	5G NR	n41	4	1	7	518598	2592.99	100	1	1	DFT-30,QPSK	100.0%	Top Side	5mm	12.5	26	11.55	25.2	3	1.75
2	Time-varying TX power	GSM	850	0	0	3	189	836.4	-	-	-	GPRS (4 Tx slots)	50.0%	Back	5mm	23	25.5	22.85	25.63	9	1.75
3		GSM	1900	0	0	3	810	1909.8	-	-	-	GPRS (4 Tx slots)	50.0%	Back	5mm	19	22.5	18.18	21.51	9	1.75
4		WCDMA	5	0	0	3	4233	846.6	-	-	-	RMC 12.2Kbps	100.0%	Back	5mm	21	23	20.55	23.55	3	1.75
5		WCDMA	2	0	0	3	9538	1907.6	-	-	-	RMC 12.2Kbps	100.0%	Back	5mm	17.5	23	16.5	23.01	3	1.75
6		LTE	26	4	1	3	26965	841.5	15	1	0	QPSK	100.0%	Back	5mm	22.2	23	22.26	23.03	3	1.75
7		LTE	66	4	1	7	132322	1745	20	1	0	QPSK	100.0%	Top Side	5mm	13	23	12.66	22.56	3	1.75
8		5G NR	n26	4	1	3	166300	831.5	20	50	28	DFT-15,QPSK	100.0%	Back	5mm	22	23	21.69	22.73	3	1.75
9		5G NR	n41	4	1	7	518598	2592.99	100	1	1	DFT-30,QPSK	100.0%	Top Side	5mm	12.5	26	11.55	25.2	3	1.75
10		Call disconnection and re-establishment	5G NR	n41	4	1	7	518598	2592.99	100	1	1	DFT-30,QPSK	100.0%	Top Side	5mm	12.5	26	11.55	25.2	3
11	Band handover	LTE	48	5	1	7	56150	3641	20	1	0	QPSK	63.3%	Back	5mm	13	21	12.43	20.91	3	1.75
		5G NR	n41	4	1	7	518598	2592.99	100	1	1	DFT-30,QPSK	100.0%	Top Side	5mm	12.5	26	11.55	25.2	3	1.75
12	Change in operating state	5G NR	n41	4	1	7	518598	2592.99	100	1	1	DFT-30,QPSK	100.0%	Top Side	5mm	12.5	26	11.55	25.2	3	1.75
		5G NR	n41	4	1	3	518598	2592.99	100	1	1	DFT-30,QPSK	100.0%	Back	5mm	15.5	26	14.55	25.2	3	1.75
13	Time window switching (60s-100s-60s)	LTE	48	5	1	7	56150	3641	20	1	0	QPSK	63.3%	Back	5mm	13	21	12.43	20.91	3	1.75
		LTE	25	4	1	7	26340	1880	20	1	0	QPSK	100.0%	Top Side	5mm	13	23	12.62	22.72	3	1.75
14	Time window switching (100s-60s-100s)	LTE	25	4	1	7	26340	1880	20	1	0	QPSK	100.0%	Top Side	5mm	13	23	12.62	22.72	3	1.75
		LTE	48	5	1	7	56150	3641	20	1	0	QPSK	63.3%	Back	5mm	13	21	12.43	20.91	3	1.75
15	SAR exposure switching (ENDC 100s/100s)	LTE	30	1	0	7	27710	2310	10	1	0	QPSK	100.0%	Back	5mm	18	23	17.01	22.03	3	1.75
		5G NR	n2	0	0	7	376000	1880	20	1	1	DFT-15,QPSK	100.0%	Bottom Side	5mm	16.5	23	15.67	22.1	3	1.75
16	SAR exposure switching (ENDC 100s/60s)	LTE	5	4	1	7	20525	836.5	10	1	0	QPSK	100.0%	Back	5mm	20.2	23	20.43	23.19	3	1.75
		5G NR	n77	2	1	7	633332	3499.98	100	1	1	DFT-30,QPSK	100.0%	Back	5mm	15	23	14.01	22.65	3	1.75

## 5.2 Conducted Power Measurement Results for Scenario1: Range of TA-SAR Gen2 Parameters

In this scenario, two parameters sets are swept to validate Mediatek’s TA-SAR Gen2 algorithm. The parameter sets are summarized in Table 6-3, and the test procedure follows section 4.2.2. The measurement setup is shown in Figure 6-1. The high-level summary of the final validation results are also listed in the last column of the table, which concludes that Mediatek’s TA-SAR Gen2 algorithm can maintain the time-averaged SAR is always below the FCC requirement for all test cases. The following section will demonstrate case-by-case to show how Mediatek’s TA-SAR Gen2 algorithm behaves for different parameters.

- **Case1: FR1 n41 result for Range of TA-SAR**

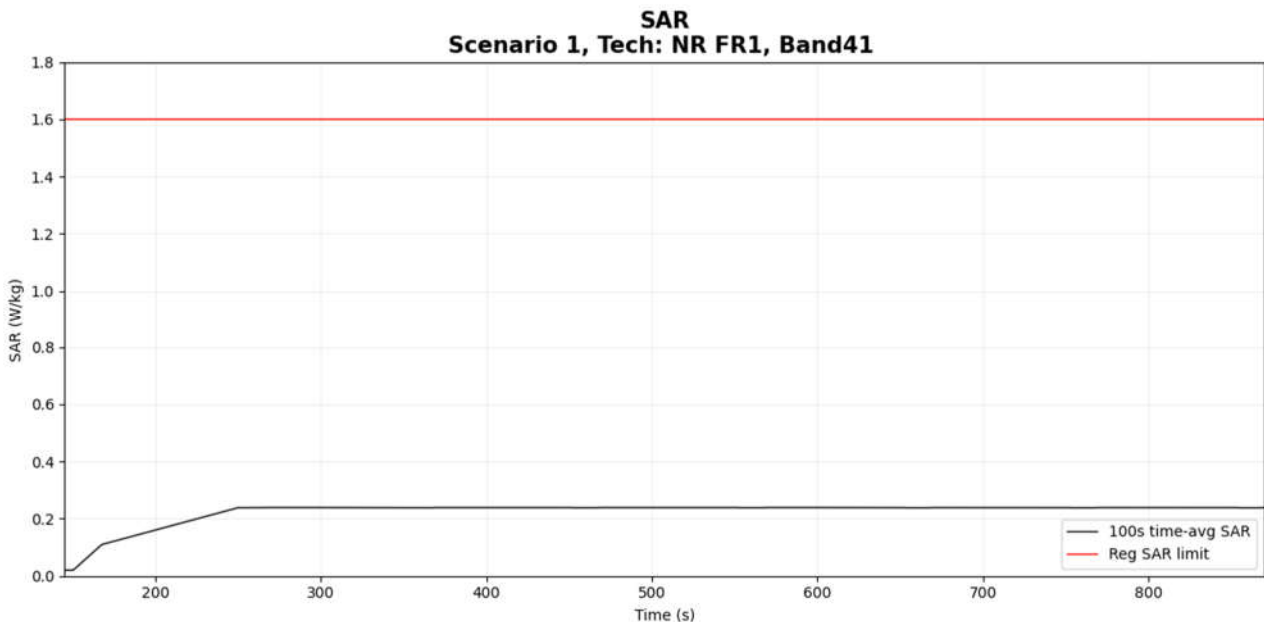

**Figure 6- 4 Time-averaged SAR**

FCC 1gSAR limit	1.6 W/kg
Max time averaged 1gSAR	0.239 W/kg
Validation result: <span style="color: green;">pass</span>	

### 5.3 Conducted Power Measurement Results for Scenario 2: Time-Varying TX Power

In this scenario, Mediatek’s TA-SAR Gen2 algorithm is tested under more dynamic power test sequences. The test sequence #1 is shown in section 4.1 and test sequence #2 is tabulated in table 4.4. All of the test cases for this scenario are relegated in Table 6-3, and the test procedure follows section 4.3.2. The measurement setup is shown in Figure 6-1. The high-level summary of the final validation results are also listed in the last column of the table, which concludes that Mediatek’s TA-SAR Gen2 algorithm can maintain the time-averaged SAR is always below the FCC requirement for all test cases. The following sections will demonstrate case-by-case to show how Mediatek’s TA-SAR Gen2 algorithm behaves for each RAT.

#### 5.3.1 Measurement results for 2G

The corresponding detailed test procedure is described in 4.3.2. For each case, TX time-averaged power is converted into time-averaged SAR by using the equation listed in section 4.3.2. The figure illustrates the corresponding time-averaged SAR. For all test cases, the time-averaged SAR does not exceed the FCC limit.

- Case2-1: GSM850 result for test sequence 1

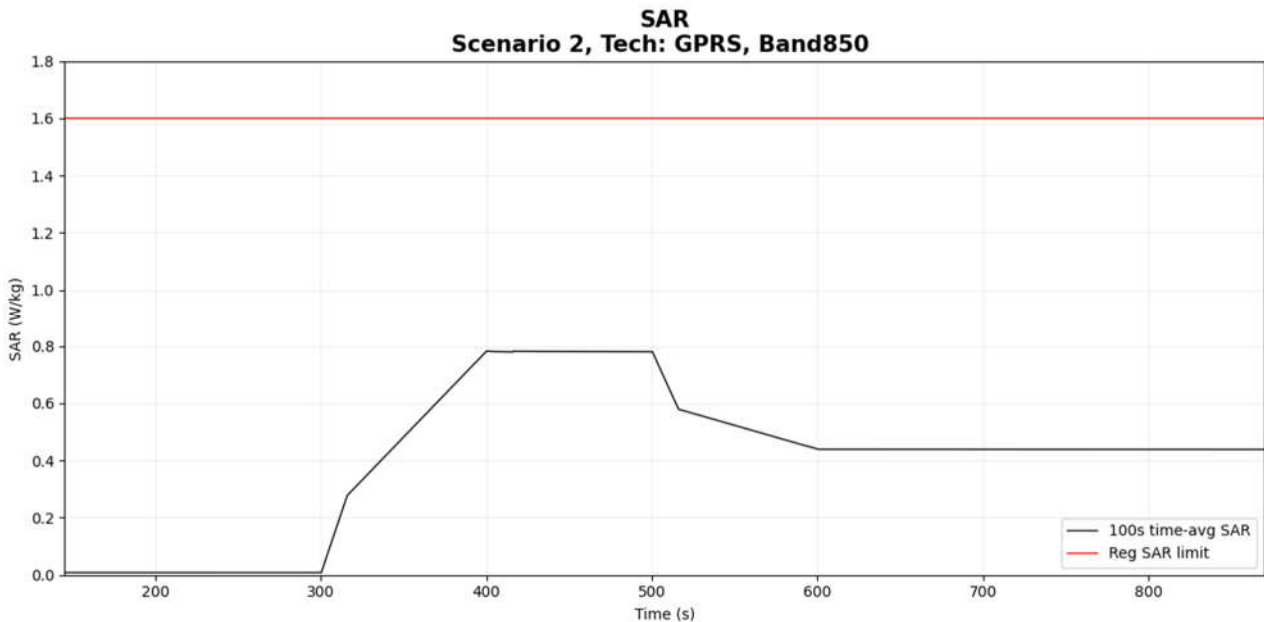
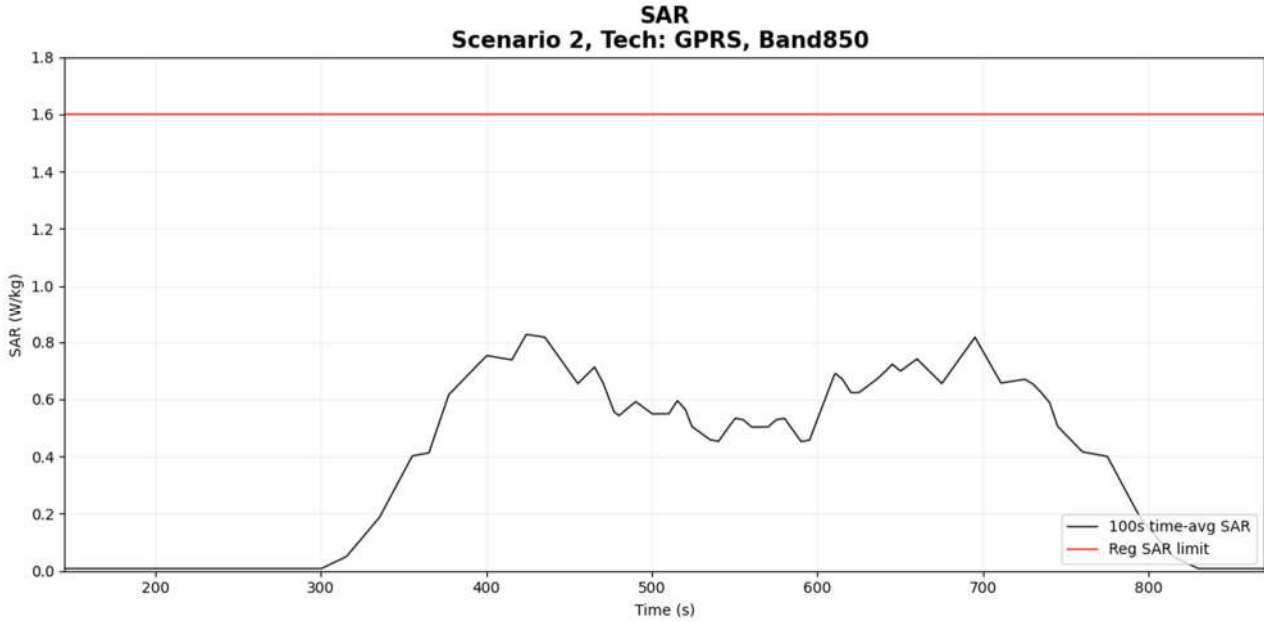

Figure 6- 5 Time-averaged SAR

FCC 1gSAR limit	1.6 W/kg
Max time averaged 1gSAR	0.783 W/kg
Validation result: <span style="color: green;">pass</span>	

- Case2-2: GSM850 result for test sequence 2



**Figure 6- 6 Time-averaged SAR**

FCC 1gSAR limit	1.6 W/kg
Max time averaged 1gSAR	0.827 W/kg
Validation result: <span style="color: green;">pass</span>	

- Case3-1: GSM1900 result for test sequence 1

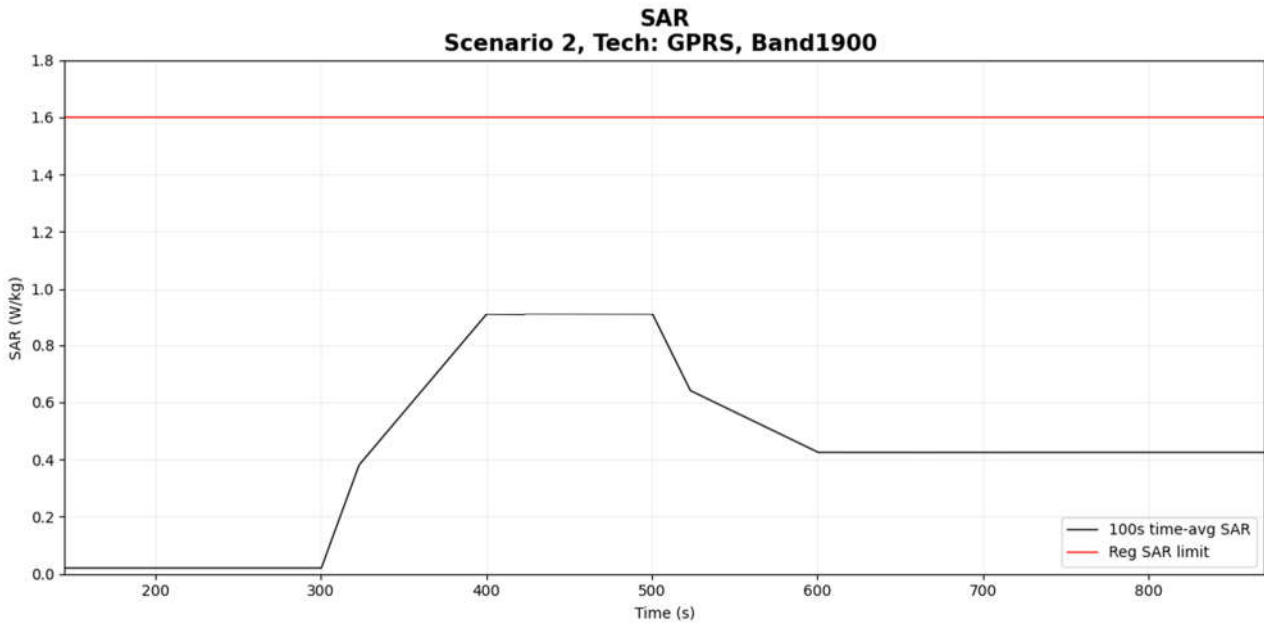

Figure 6- 7 Time-averaged SAR

FCC 1gSAR limit	1.6 W/kg
Max time averaged 1gSAR	0.910 W/kg
Validation result: <span style="color: green;">pass</span>	

- Case3-2: GSM1900 result for test sequence 2

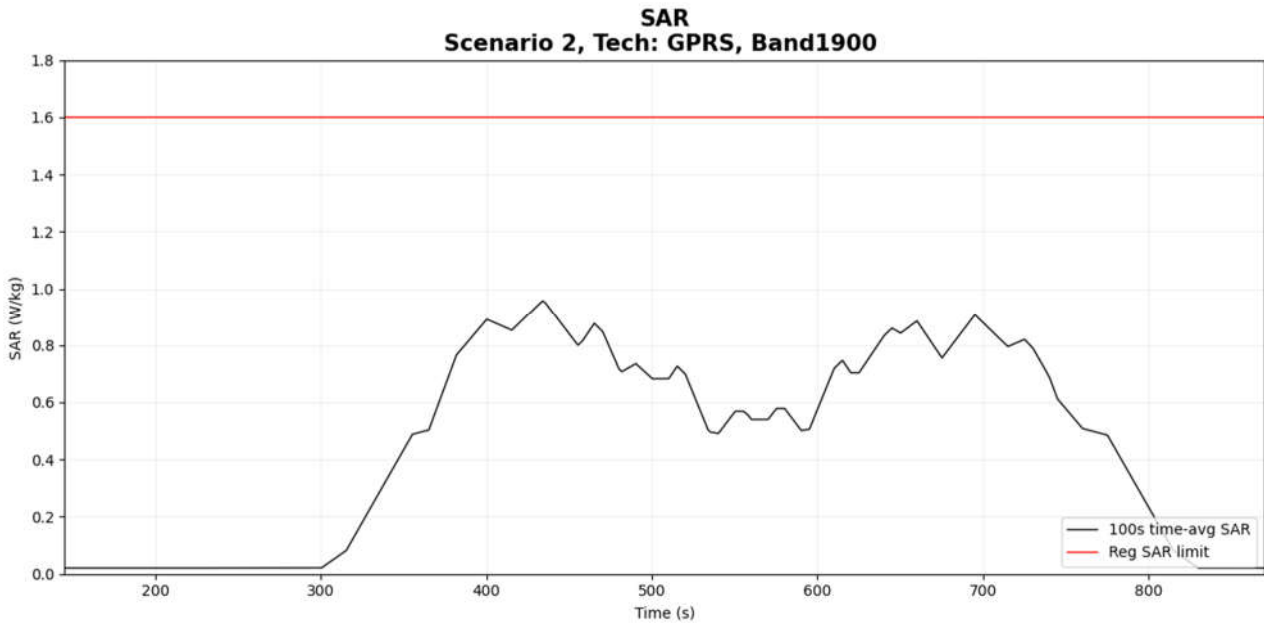

Figure 6- 8 Time-averaged SAR

FCC 1gSAR limit	1.6 W/kg
Max time averaged 1gSAR	0.957 W/kg
Validation result: <span style="color: green;">pass</span>	

### 5.3.2 Measurement results for 3G

The corresponding detailed test procedure is described in 4.3.2. For each case, TX time-averaged power is converted into time-averaged SAR by using the equation listed in section 4.3.2. The figure illustrates the corresponding time-averaged SAR. For all test cases, the time-averaged SAR does not exceed the FCC limit.

- Case4-1: WCDMA B5 result for test sequence 1

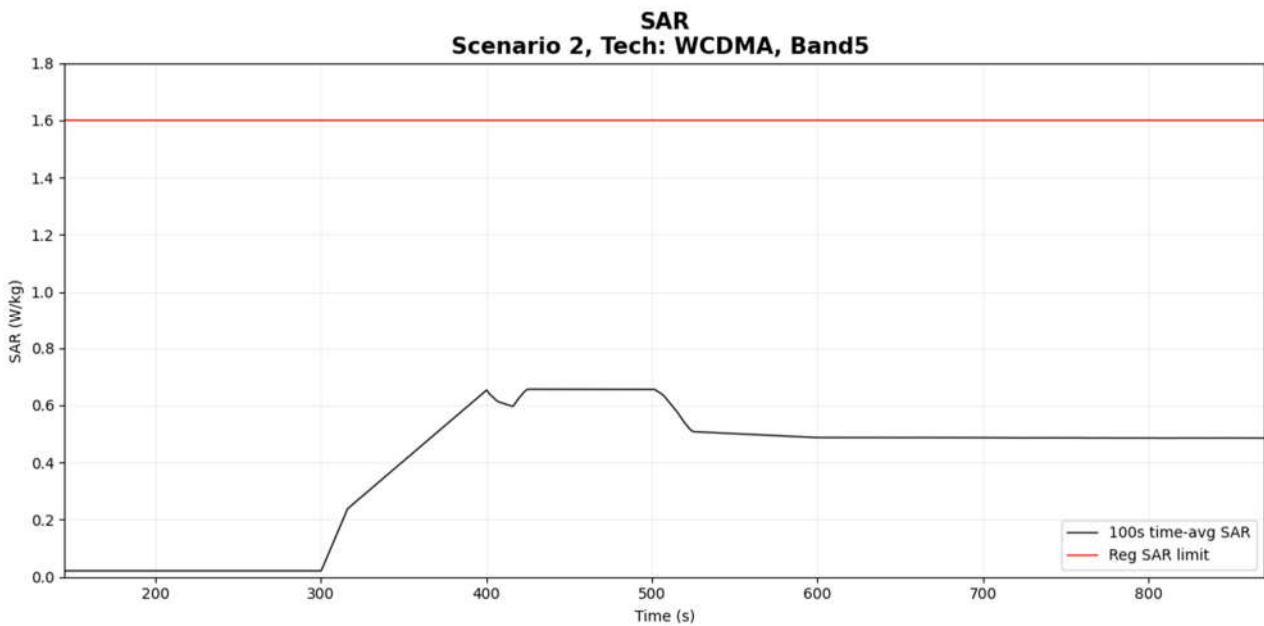
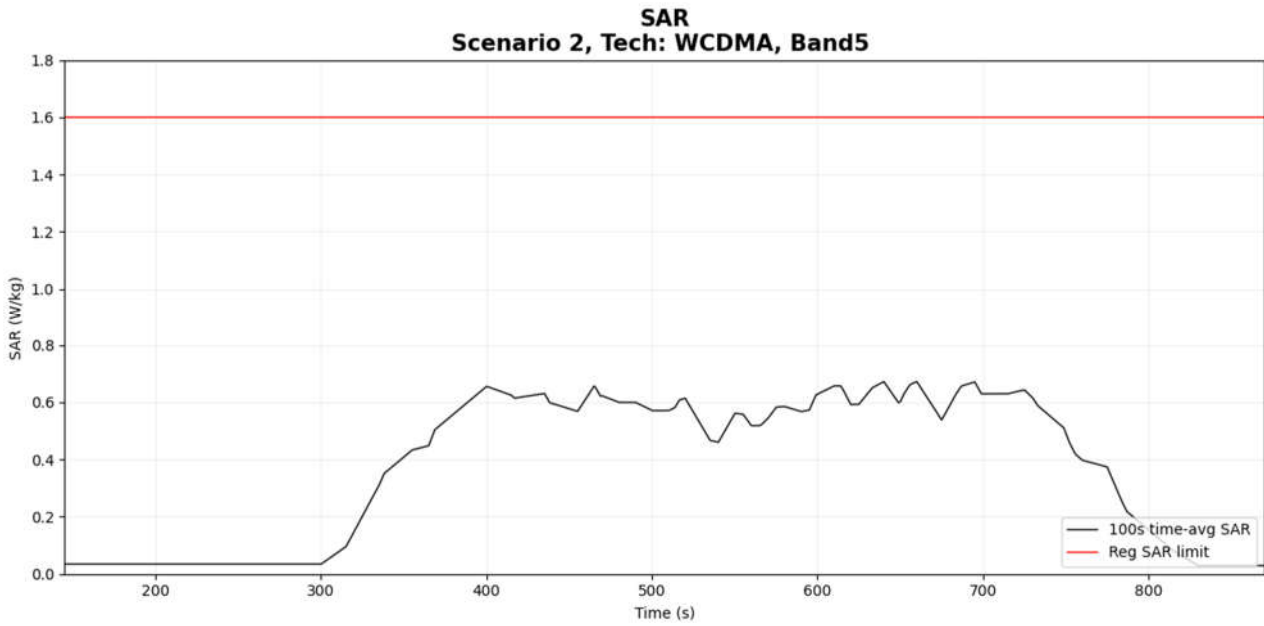

Figure 6- 9 Time-averaged SAR

FCC 1gSAR limit	1.6 W/kg
Max time averaged 1gSAR	0.656 W/kg
Validation result: <span style="color: green;">pass</span>	

- Case4-2: WCDMA B5 result for test sequence 2



**Figure 6- 10 Time-averaged SAR**

FCC 1gSAR limit	1.6 W/kg
Max time averaged 1gSAR	0.672 W/kg
Validation result: <span style="color: green;">pass</span>	

- Case5-1: WCDMA B2 result for test sequence 1

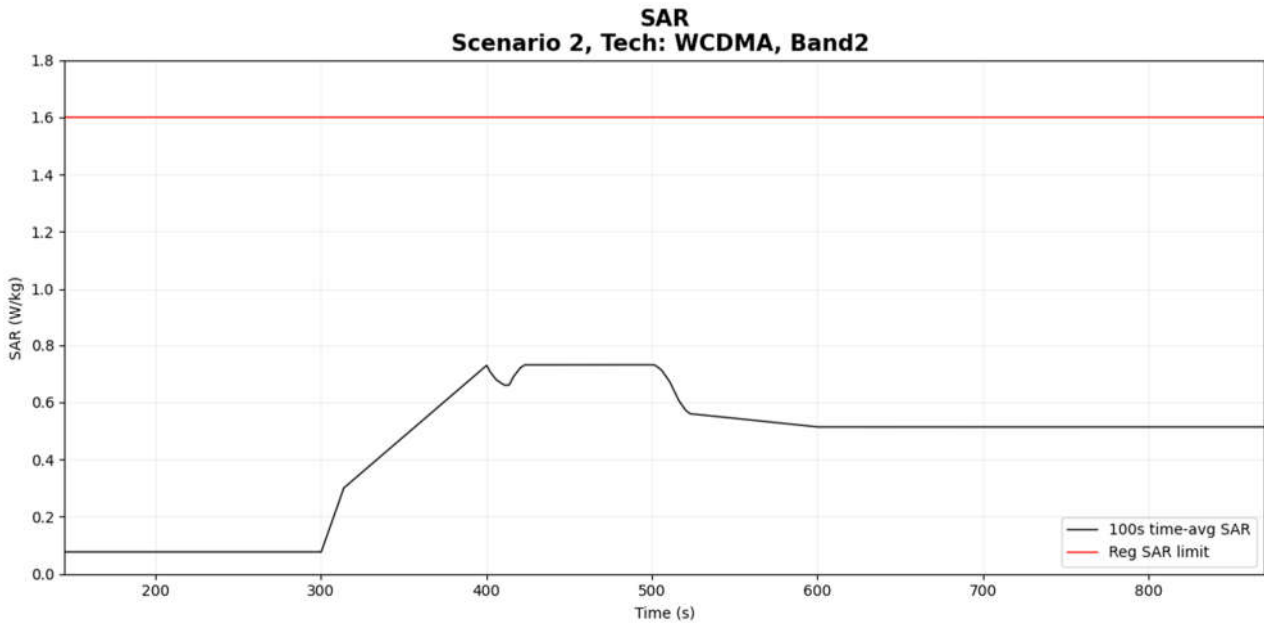

Figure 6- 11 Time-averaged SAR

FCC 1gSAR limit	1.6 W/kg
Max time averaged 1gSAR	0.731 W/kg
Validation result: <span style="color: green;">pass</span>	

● Case5-2: WCDMA B2 result for test sequence 2

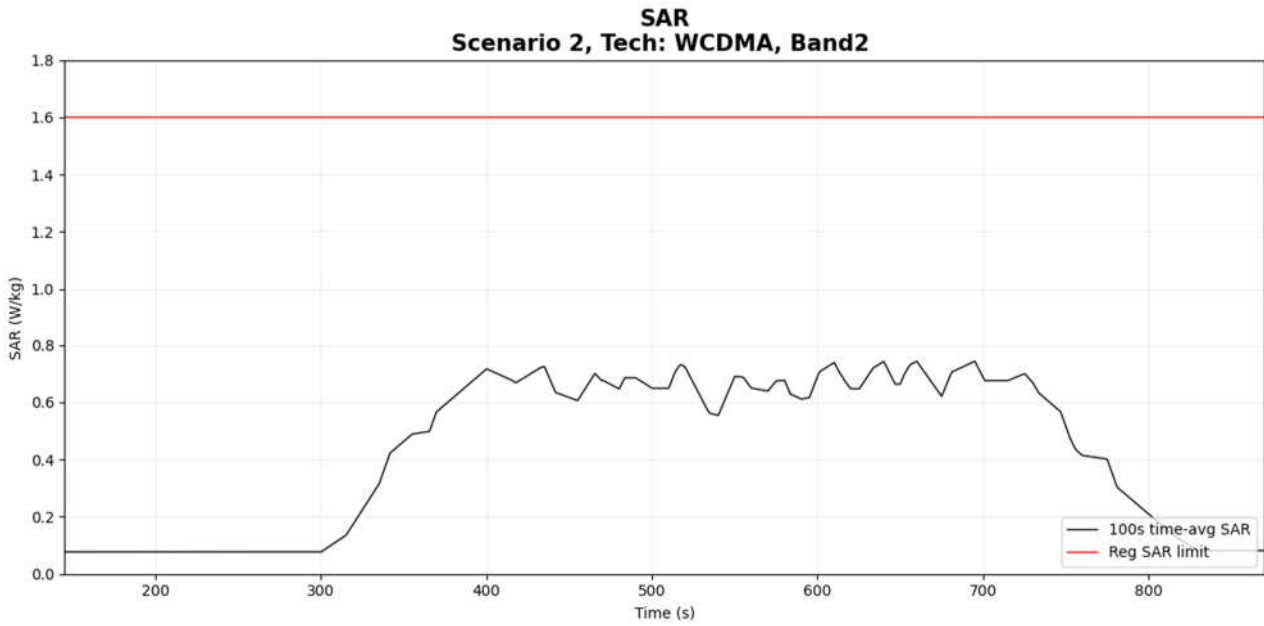

Figure 6- 12 Time-averaged SAR

FCC 1gSAR limit	1.6 W/kg
Max time averaged 1gSAR	0.743 W/kg
Validation result: <span style="color: green;">pass</span>	

### 5.3.3 Measurement results for LTE

The corresponding detailed test procedure is described in 4.3.2. For each case, TX time-averaged power is converted into time-averaged SAR by using the equation listed in section 4.3.2. The figure illustrates the corresponding time-averaged SAR. For all test cases, the time-averaged SAR does not exceed the FCC limit.

- Case6-1: LTE Band 26 result for test sequence 1

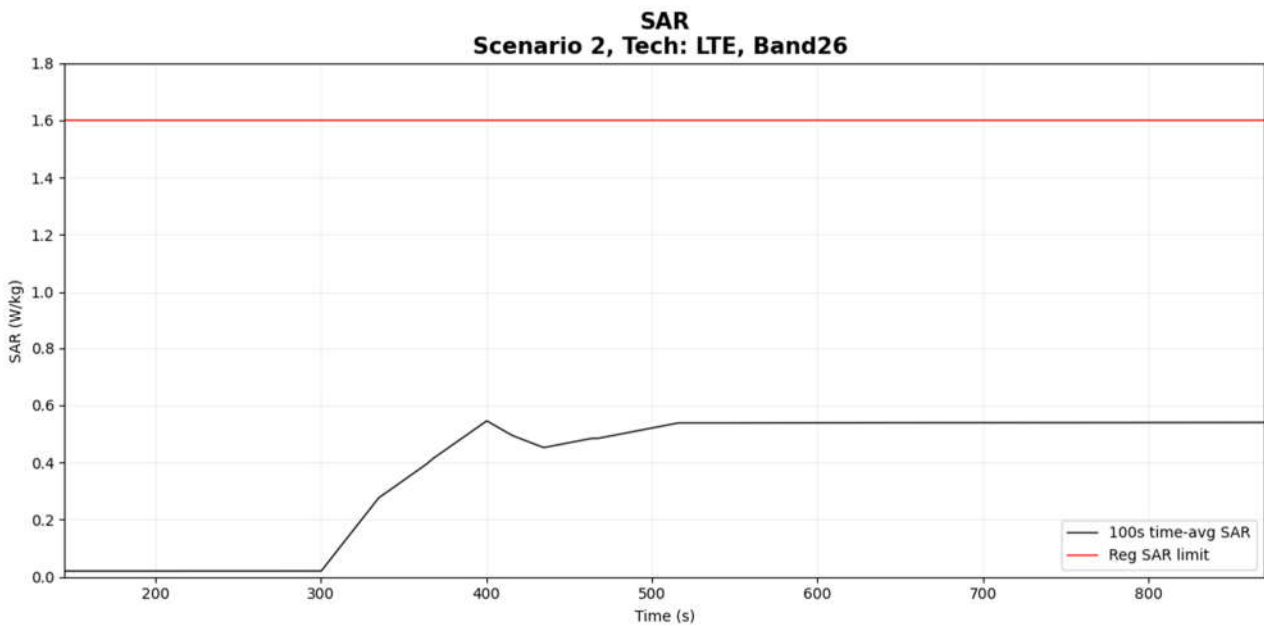

Figure 6- 13 Time-averaged SAR

FCC 1gSAR limit	1.6 W/kg
Max time averaged 1gSAR	0.546 W/kg
Validation result: <span style="color: green;">pass</span>	

- Case6-2: LTE Band 26 result for test sequence 2

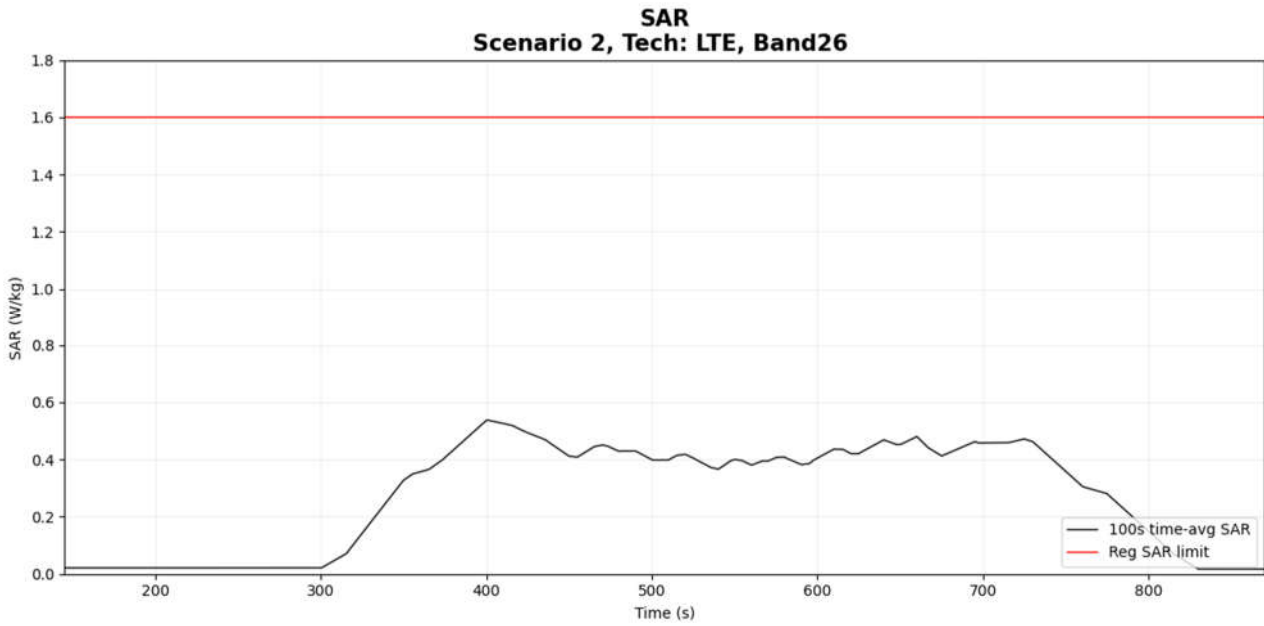

Figure 6- 14 Time-averaged SAR

FCC 1gSAR limit	1.6 W/kg
Max time averaged 1gSAR	0.538 W/kg
Validation result: <span style="color: green;">pass</span>	

- Case7-1: LTE Band 66 result for test sequence 1

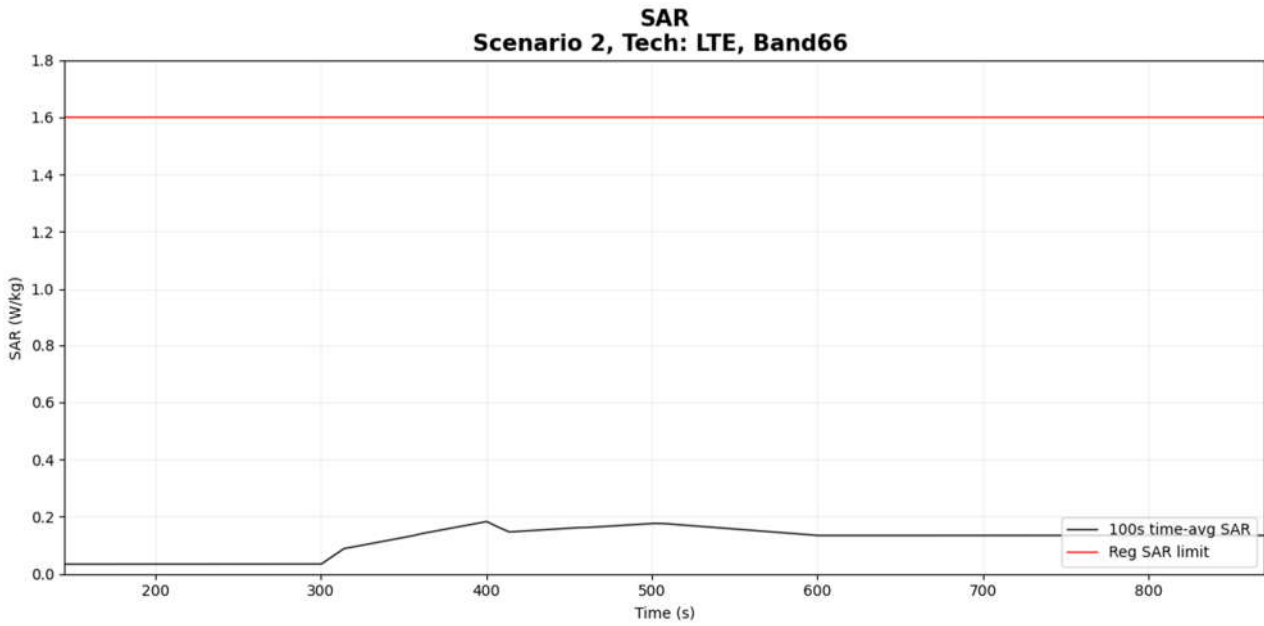

Figure 6- 15 Time-averaged SAR

FCC 1gSAR limit	1.6 W/kg
Max time averaged 1gSAR	0.184 W/kg
Validation result: <span style="color: green;">pass</span>	

- Case7-2: LTE Band 66 result for test sequence 2

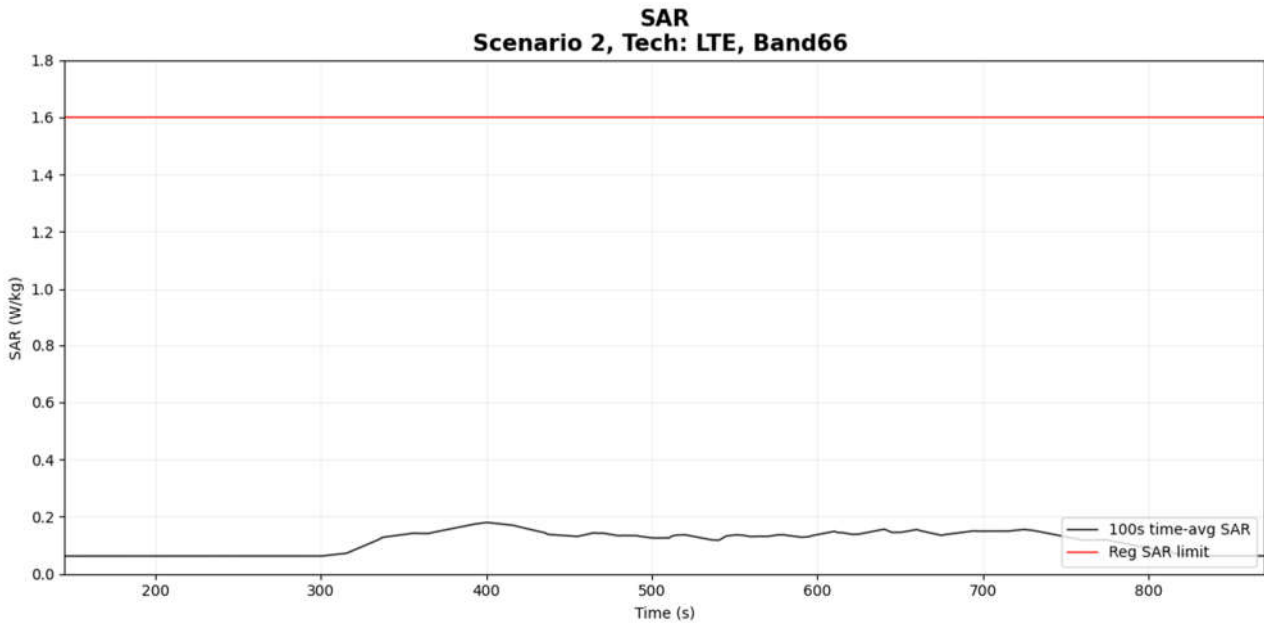

Figure 6- 16 Time-averaged SAR

FCC 1gSAR limit	1.6 W/kg
Max time averaged 1gSAR	0.180 W/kg
Validation result: <span style="color: green;">pass</span>	

### 5.3.4 Measurement results for NR

The corresponding detailed test procedure is described in 4.3.2. For each case, TX time-averaged power is converted into time-averaged SAR by using the equation listed in section 4.3.2. The figure illustrates the corresponding time-averaged SAR. For all test cases, the time-averaged SAR does not exceed the FCC limit.

- Case8-1: FR1 n26 result for test sequence 1

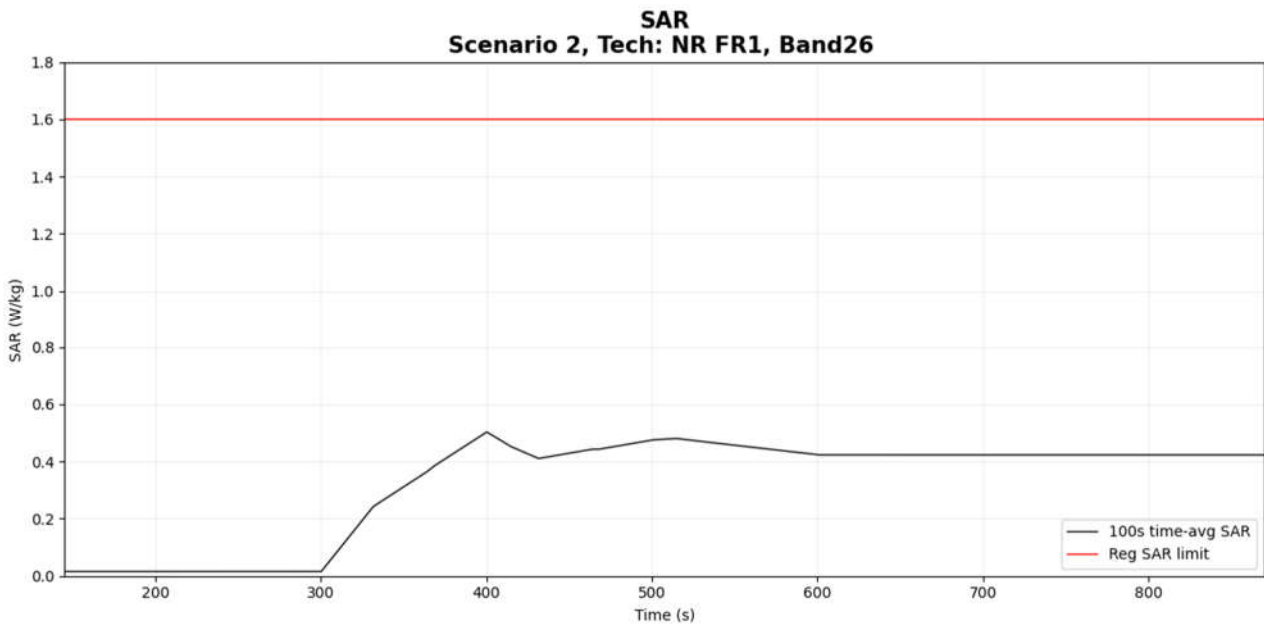
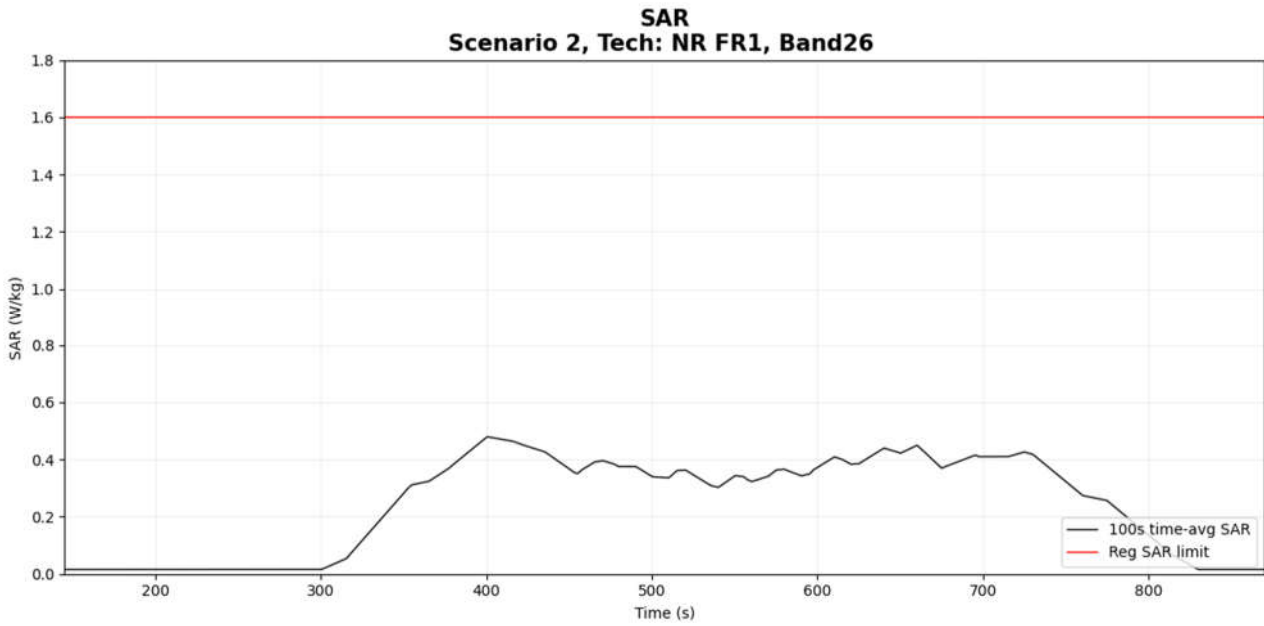

Figure 6- 17 Time-averaged SAR

FCC 1gSAR limit	1.6 W/kg
Max time averaged 1gSAR	0.503 W/kg
Validation result: <span style="color: green;">pass</span>	

- Case8-2: FR1 n26 result for test sequence 2



**Figure 6- 18 Time-averaged SAR**

FCC 1gSAR limit	1.6 W/kg
Max time averaged 1gSAR	0.480 W/kg
Validation result: <span style="color: green;">pass</span>	

- Case9-1: FR1 n41 result for test sequence 1

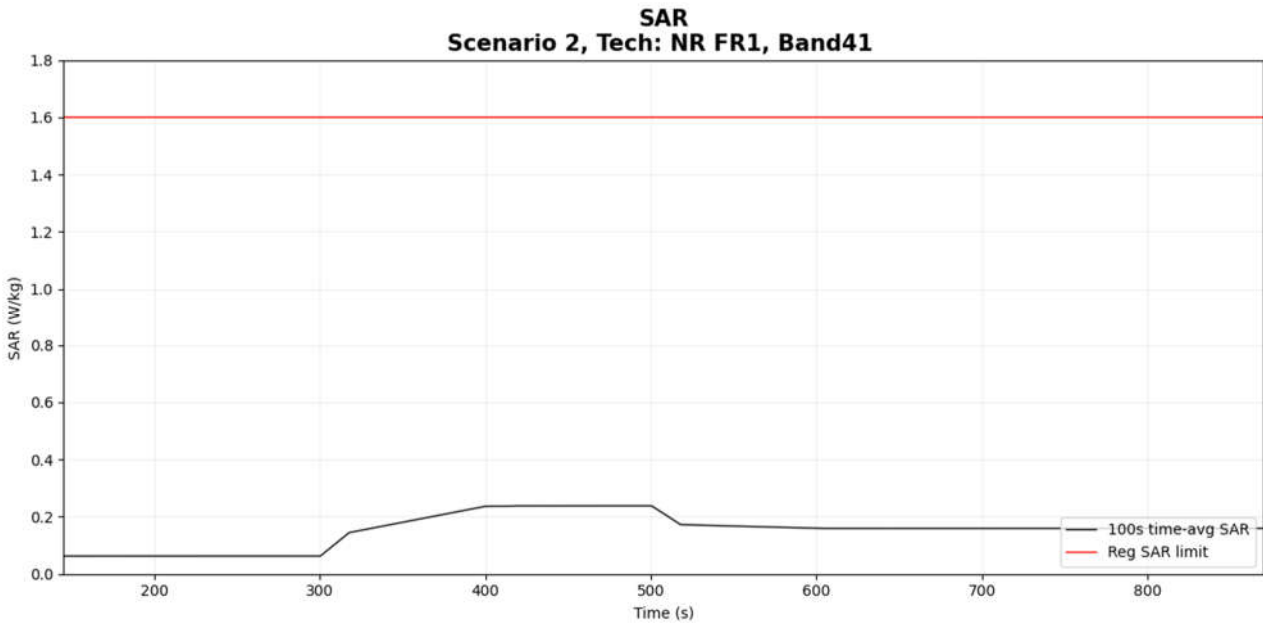
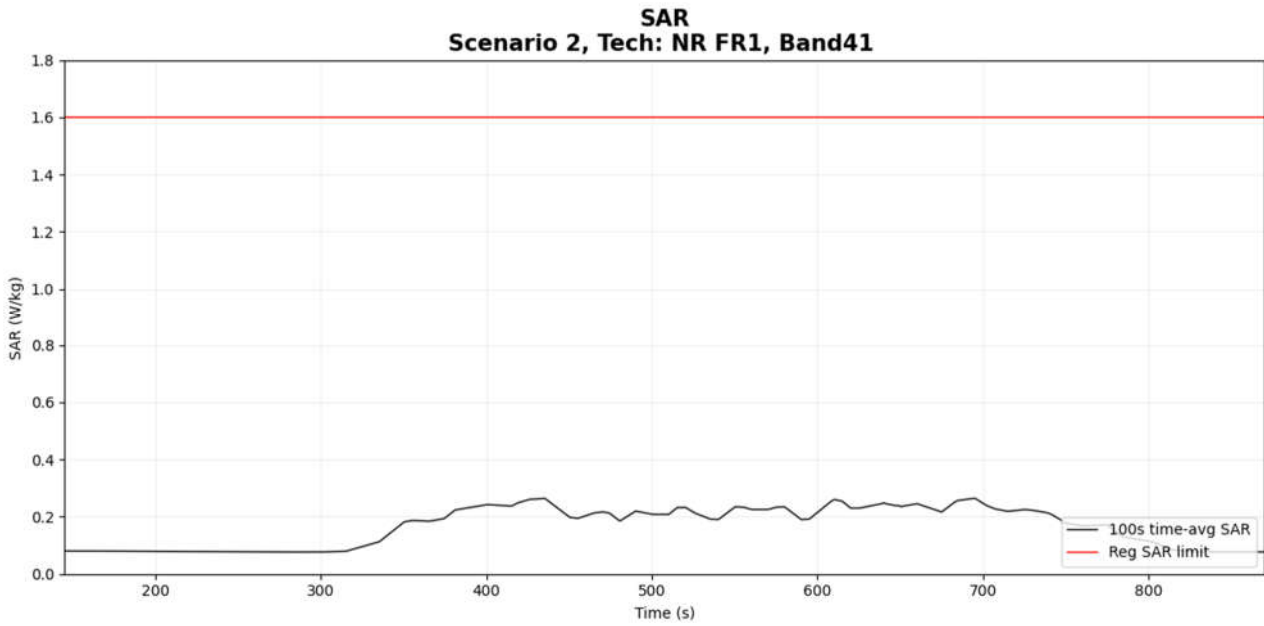

Figure 6- 19 Time-averaged SAR

FCC 1gSAR limit	1.6 W/kg
Max time averaged 1gSAR	0.238 W/kg
Validation result: <span style="color: green;">pass</span>	

- Case9-2: FR1 n41 result for test sequence 2



**Figure 6- 20 Time-averaged SAR**

FCC 1gSAR limit	1.6 W/kg
Max time averaged 1gSAR	0.265 W/kg
Validation result: <span style="color: green;">pass</span>	

### 5.4 Conducted Power Measurement Results for Scenario 3: Call Disconnection and Re-establishment

In this scenario, the test power sequence #0 (i.e., maximum TX power is requested by a call box for each RAT) is used, and the call drop is manually configured for a pre-defined period and then the call is re-established to continue data transmission. The test case for this scenario is relegated in Table 6-3, and the test procedure follows section 4.4.2. The measurement setup is shown in Figure 6-1. The high-level summary of the final validation results is also listed in the last column of the table, which concludes that Mediatek’s TA-SAR Gen2 algorithm can maintain the time-averaged SAR is always below the FCC requirement. The following section will demonstrate how Mediatek’s TA-SAR Gen2 algorithm behaves.

The corresponding detailed test procedure is described in 4.4.2. For this case, TX time-averaged power is converted into time-averaged SAR by using the equation listed in section 4.4.2. The figure illustrates the corresponding time-averaged SAR. As seen in this figure, the time-averaged SAR does not exceed the FCC limit.

- **Case10: FR1 n41 call drop happens at the time instance of 500 seconds.**

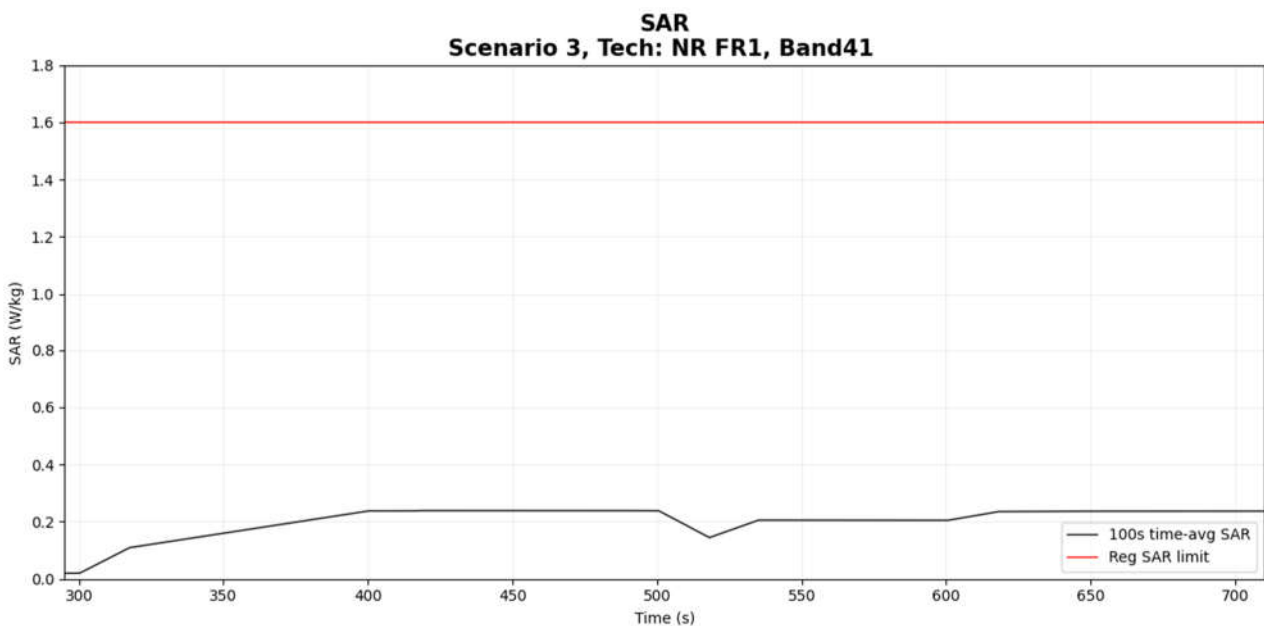

**Figure 6- 21 Time-averaged SAR**

FCC 1gSAR limit	1.6 W/kg
Max time averaged 1gSAR	0.239 W/kg
Validation result: <span style="color: green;">pass</span>	

## 5.5 Conducted Power Measurement Results for Scenario 4: Band Handover

In this scenario, the test power sequence #0 (i.e., maximum TX power is requested by a call box for each RAT/band) is used, and band (and RAT) handover is manually configured at a specific time instance. The test case widely cover handover scenarios between two RATs. The test case for this scenario is relegated in Table 6-3, and the test procedure follows section 4.5.2. The measurement setup is shown in Figure 6-3 (RAT handover). The high-level summary of the final validation results is also listed in the last column of the table, which concludes that Mediatek’s TA-SAR Gen2 algorithm can maintain the time-averaged SAR is always below the FCC requirement. The following section will demonstrate how Mediatek’s TA-SAR Gen2 algorithm behaves.

This test case to validate the TA-SAR Gen2 algorithm with a handover from LTE Band 48 to 5G NR n41 and ECI = 7. The corresponding detailed test procedure is described in 4.5.2. The handover is configured at the time instance of 500 seconds. For this case, TX time-averaged power results are converted into normalized time-averaged SAR by using the equation listed in section 4.5.2. The figure illustrates the corresponding normalized time-averaged SAR, as well as total normalized time-averaged SAR. The figure shows that the time-averaged normalized SAR does not exceed the normalized FCC limit of 1.

- **Case11: band handover happens at the time instance of 500 seconds.**

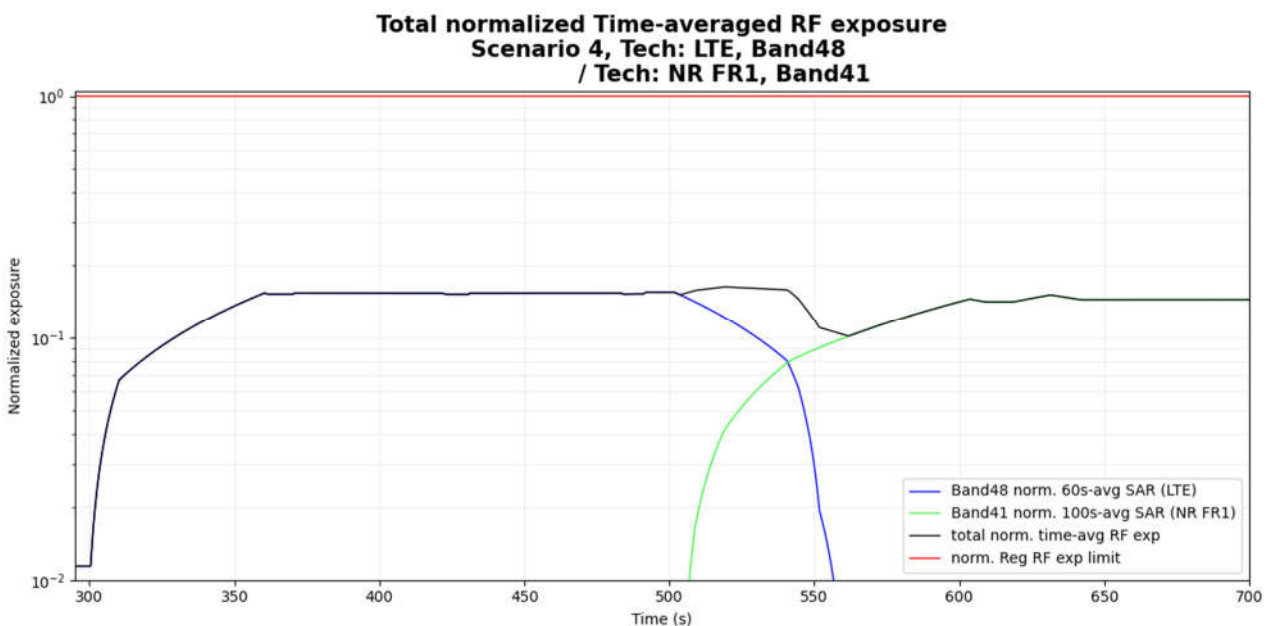

**Figure 6- 22 Normalized time-averaged SAR**

FCC limit of total RF exposure (normalized)	1.0
Max total normalized time-averaged RF exposure	0.163
Validation result: <span style="color: green;">pass</span>	

### 5.6 Conducted Power Measurement Results for Scenario 5: ECI Change

In this scenario, the test power sequence #0 (i.e., maximum TX power is requested by a call box for each RAT) is used, and ECI change at the EUT side is manually configured at a specific time instance. The test case cover ECI switching scenario between two ECIs. The test case for this scenario is relegated in Table 6-3, and the test procedure follows section 4.6.2. The measurement setup is shown in Figure 6-1. The high-level summary of the final validation results is also listed in the last column of the table, which concludes that Mediatek’s TA-SAR Gen2 algorithm can maintain the time-averaged SAR is always below the FCC requirement. The following section will demonstrate how Mediatek’s TA-SAR Gen2 algorithm behaves.

The corresponding detailed test procedure is described in 4.6.2. During the test period, there are two ECI change events configured individually at the time instances 500 seconds and 700 seconds. The 1<sup>st</sup> change is from ECI = 7 to ECI = 3 and the 2<sup>nd</sup> change is from ECI = 3 back to ECI = 7. For this case, TX time-averaged power results are converted into normalized time-averaged SAR by using the equation listed in section 4.6.2. The figure illustrates the corresponding normalized time-averaged SAR, as well as the total normalized time-averaged SAR. The figure shows that the time-averaged normalized SAR does not exceed the normalized FCC limit of 1.

- Case12: 5GNR n41 ECI 7 changes to ECI 3 happen at the time instances of 500 and 700 seconds, respectively

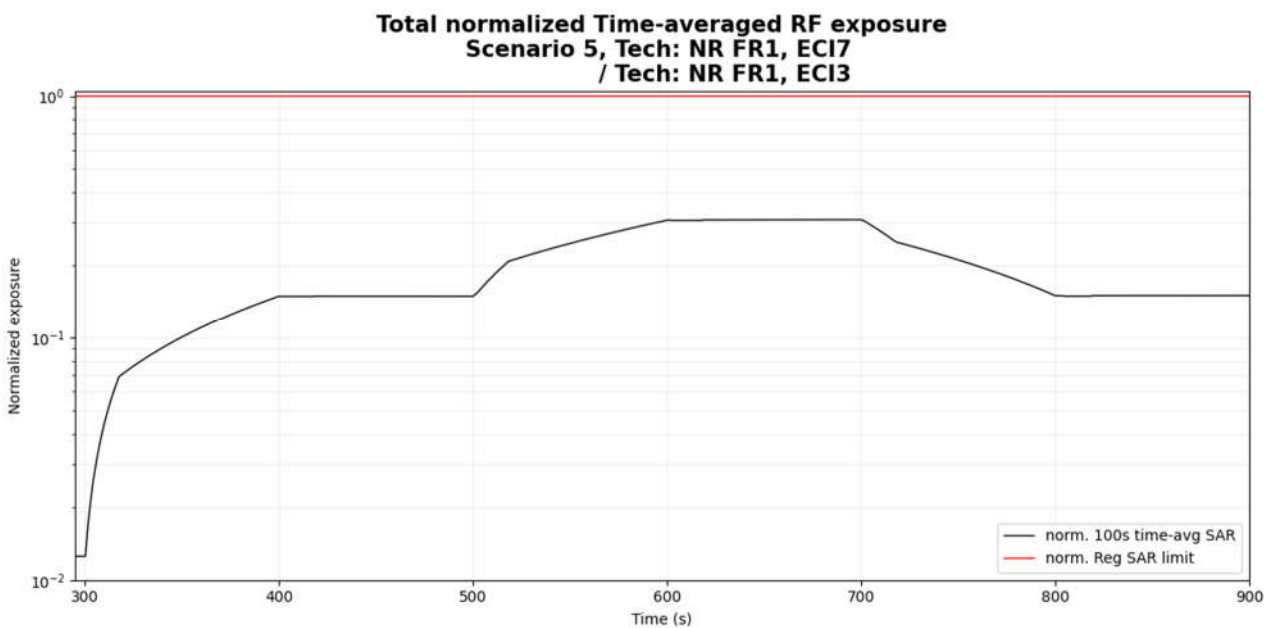

Figure 6- 23 Normalized time-averaged SAR

FCC limit of total RF exposure (normalized)	1.0
Max total normalized time-averaged RF exposure	0.309
Validation result: <span style="color: green;">pass</span>	

## 5.7 Conducted Power Measurement Results for Scenario 7: Time Window Switching

In this scenario, the test power sequence #0 (i.e., maximum TX power is requested by a call box for each RAT/band) is used, and band handover events within a RAT are manually configured at specific time instances. This scenario aims to validate the correctness of the TA-SAR Gen2 algorithm with existence of moving average time window change. The two test cases for this scenario are relegated in Table 6-3, and the test procedure follows section 4.8.2. The measurement setup is shown in Figure 6-2. The high-level summary of the final validation results are also listed in the last column of the table, which concludes that Mediatek’s TA-SAR Gen2 algorithm can maintain the time-averaged SAR is always below the FCC requirement for all the cases. The following sections will demonstrate how Mediatek’s TA-SAR Gen2 algorithm behaves.

### 5.7.1 Measurement results for Time window switching 60s-100s-60s

The corresponding detailed test procedure is described in 4.8.2. During the test period, there are two band handover events configured individually at the time instances 420 seconds and 620 seconds. The 1<sup>st</sup> handover is from LTE Band 48 to LTE Band 25 and the 2<sup>nd</sup> handover is from LTE Band 25 back to LTE Band 48.

For this case, TX time-averaged power results are converted into normalized time-averaged SAR by using the equation listed in section 4.8.2. The figure illustrates the corresponding normalized time-averaged SAR, as well as the total normalized time-averaged SAR. The figure shows that the time-averaged normalized SAR does not exceed the normalized FCC limit of 1.

- **Case13: LTE Band 48 handover to LTE Band 25 happens at the time instances of 420 and 620 seconds.**

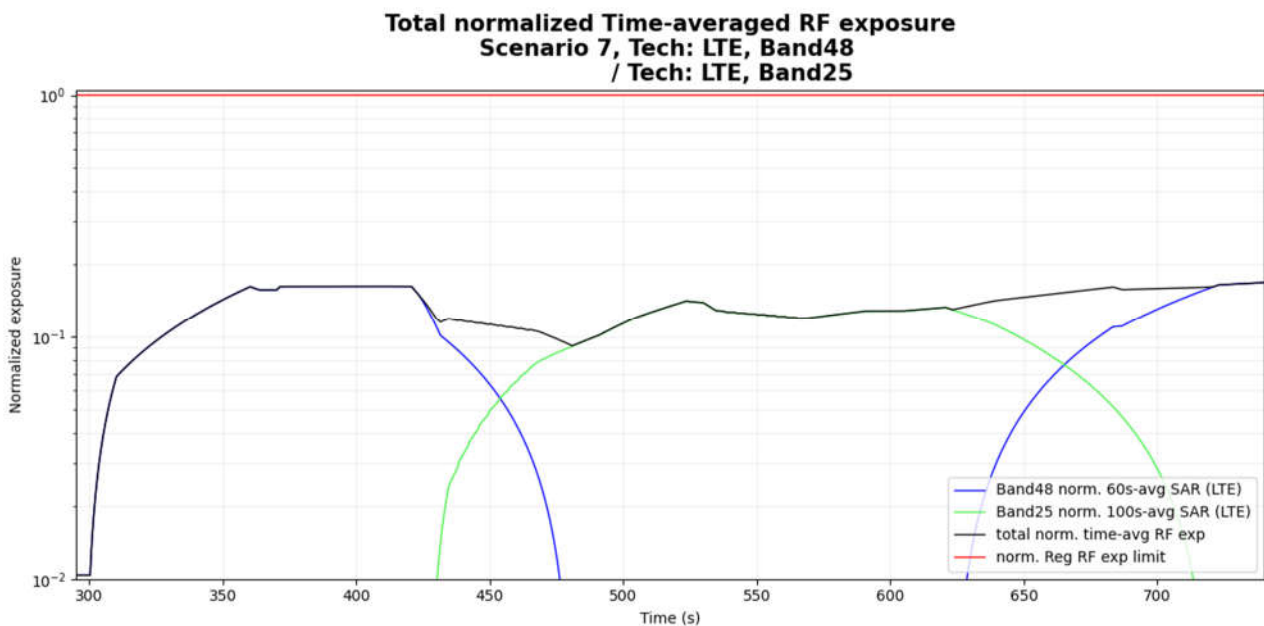

**Figure 6- 24 Normalized time-averaged SAR**

FCC limit of total RF exposure (normalized)	1.0
Max total normalized time-averaged RF exposure	0.169
Validation result: <span style="color: green;">pass</span>	

### 5.7.2 Measurement results for Time window switching 100s-60s-100s

The corresponding detailed test procedure is described in 4.8.2. During the test period, there are two band handover events configured individually at the time instances 500 seconds and 620 seconds. The 1<sup>st</sup> handover is from LTE Band 25 to LTE Band 48 and the 2<sup>nd</sup> handover is from LTE Band 48 back to LTE Band 25.

For this case, TX time-averaged power results are converted into normalized time-averaged SAR by using the equation listed in section 4.8.2. The figure illustrates the corresponding normalized time-averaged SAR, as well as the total normalized time-averaged SAR. The figure shows that the time-averaged normalized SAR does not exceed the normalized FCC limit of 1.

- Case14: LTE Band 25 handover to LTE Band 48 happens at the time instances of 500 and 620 seconds.

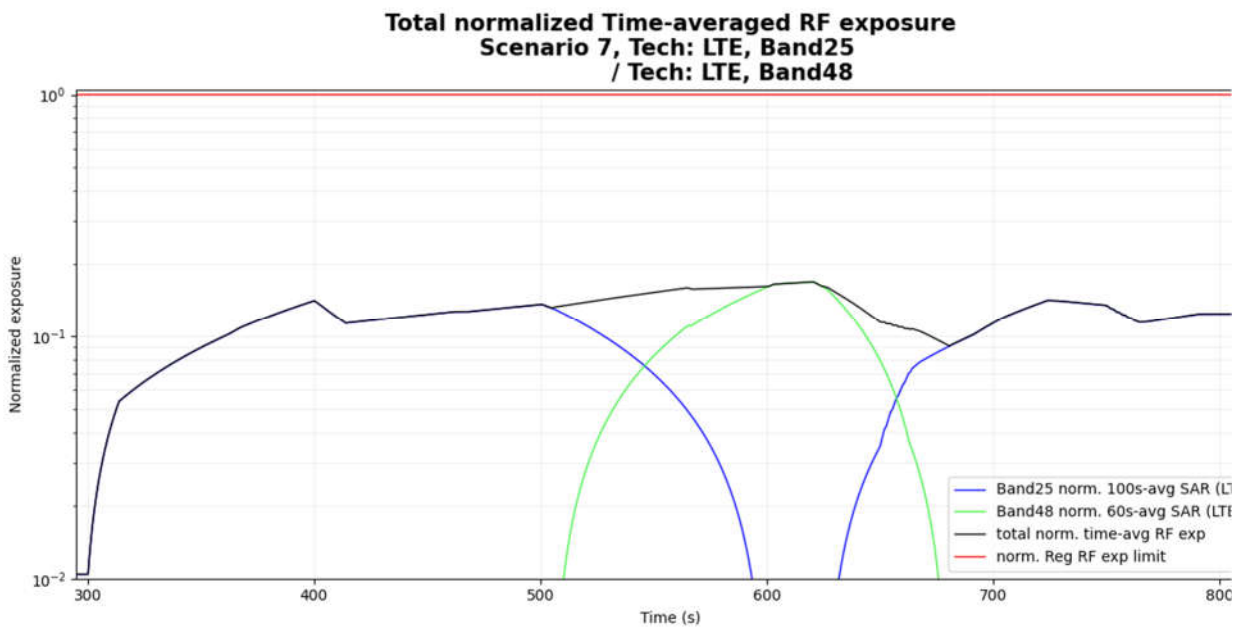

Figure 6- 25 Normalized time-averaged SAR

FCC limit of total RF exposure (normalized)	1.0
Max total normalized time-averaged RF exposure	0.169
Validation result: <span style="color: green;">pass</span>	

### 5.8 Conducted Power Measurement Results for Scenario 8: SAR Exposure Switching (EN-DC Combination in the same time window)

In this scenario, the test power sequence #0 (i.e., maximum TX power is requested by a call box for each RAT/band) is used, and FR1 n2 and LTE Band 30 are turned on at the same time for a pre-defined period during the test. This scenario aims to validate whether the TA-SAR Gen2 algorithm is able to maintain TER below the FCC limit when the two radios change TX power dynamically. The experiment parameters are summarized in Table 6-3, and the test procedure follows section 4.9.2. The measurement setup is shown in Figure 6-3.

During the test period,

- Time = 300s~500s: FR1 n2 predominant scenario.
- Time = 500s~700s: LTE Band 30 + FR1 n2 scenario.
- Time = 700s~900s: LTE Band 30 predominant scenario.

For this case, TX time-averaged power results are converted into normalized time-averaged SAR by using the equation listed in section 4.9.2. The figure illustrates the corresponding normalized time-averaged SAR, as well as the total normalized time-averaged SAR. The figure shows that the time-averaged normalized SAR does not exceed the normalized FCC limit of 1.

- **Case15: SAR Exposure Switch for FR1 n2 to LTE Band 30**

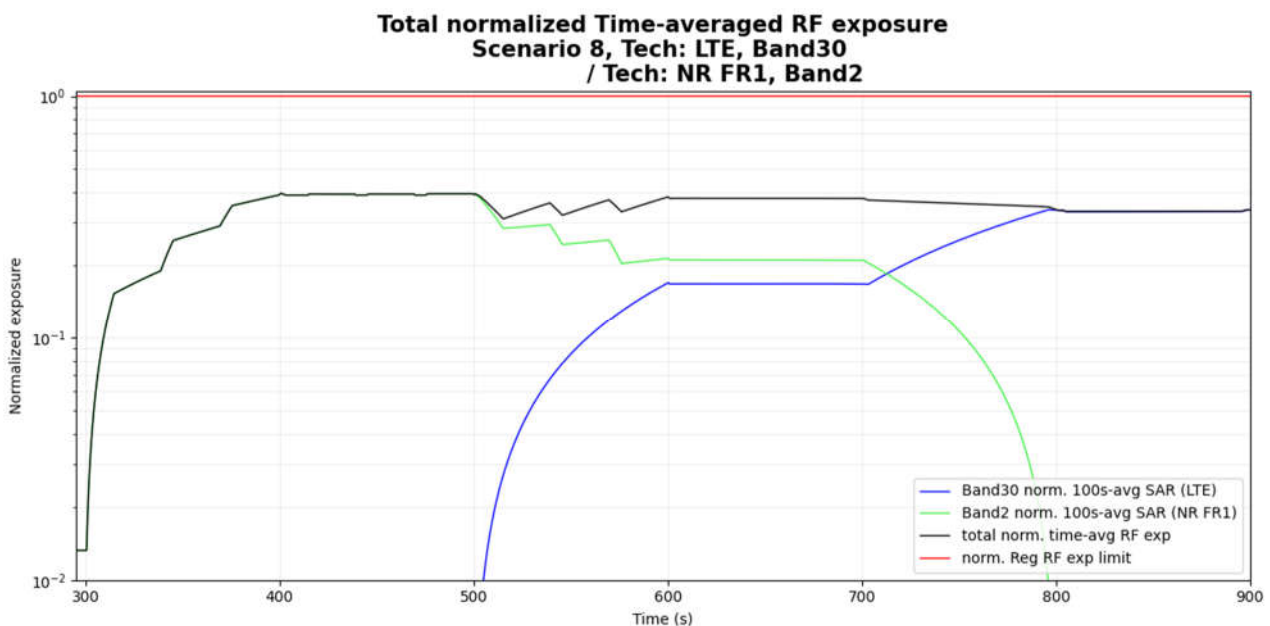

Figure 6- 26 Normalized time-averaged SAR

FCC limit of total RF exposure (normalized)	1.0
Max total normalized time-averaged RF exposure	0.397
Validation result: <span style="color: green;">pass</span>	

### 5.9 Conducted Power Measurement Results for Scenario 8: SAR Exposure Switching (EN-DC Combination in the different time window)

In this scenario, the test power sequence #0 (i.e., maximum TX power is requested by a call box for each RAT/band) is used, and FR1 n77 and LTE Band 5 are turned on at the same time for a pre-defined period during the test. This scenario aims to validate whether the TA-SAR Gen2 algorithm is able to maintain TER below the FCC limit when the two radios change TX power dynamically. The experiment parameters are summarized in Table 6-3, and the test procedure follows section 4.9.2. The measurement setup is shown in Figure 6-3.

During the test period,

- Time = 300s~500s: FR1 n77 predominant scenario.
- Time = 500s~700s: LTE Band 5 + FR1 n77 scenario.
- Time = 700s~900s: LTE Band 5 predominant scenario.

For this case, TX time-averaged power results are converted into normalized time-averaged SAR by using the equation listed in section 4.9.2. The figure illustrates the corresponding normalized time-averaged SAR, as well as the total normalized time-averaged SAR. The figure shows that the time-averaged normalized SAR does not exceed the normalized FCC limit of 1.

- **Case16: SAR Exposure Switch for FR1 n77 to LTE Band 5**

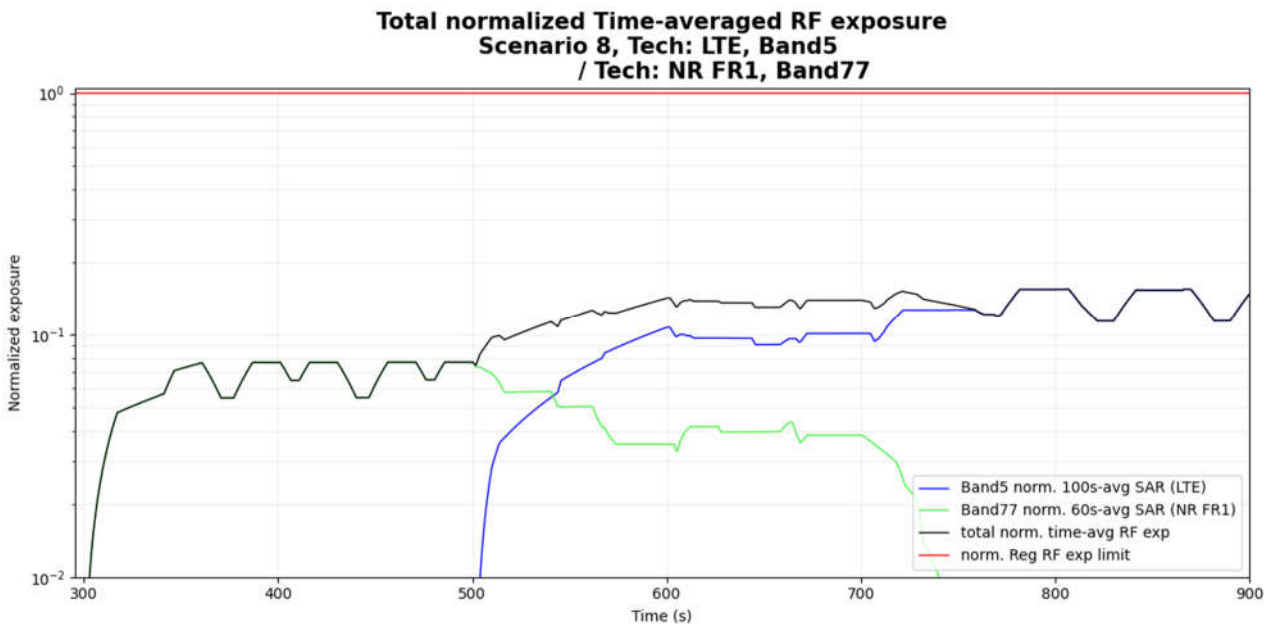

Figure 6- 27 Normalized time-averaged SAR

FCC limit of total RF exposure (normalized)	1.0
Max total normalized time-averaged RF exposure	0.155
Validation result: <span style="color: green;">pass</span>	

## 6. TA-SAR Gen2 Validation via SAR Measurements

### 6.1 Measurement Setup

The measurement setup is similar to normal fixed power SAR measurement. The difference in SAR measurement setup for time averaging feature validation is that the call box operates under the close loop power control mode and is connected to the PC, so that the PC can control the call box based on the test sequence to configure EUT's TX target power. The same test procedure used in conducted power setup for time-varying TX power measurement is also used in this section for time-averaging SAR measurements. Since the SAR chamber is an uncontrolled environment, the path loss between call box antenna and the EUT are well calibrated. The test setup is illustrated in Figure 7-1, and its photos are shown in Setup Photos.

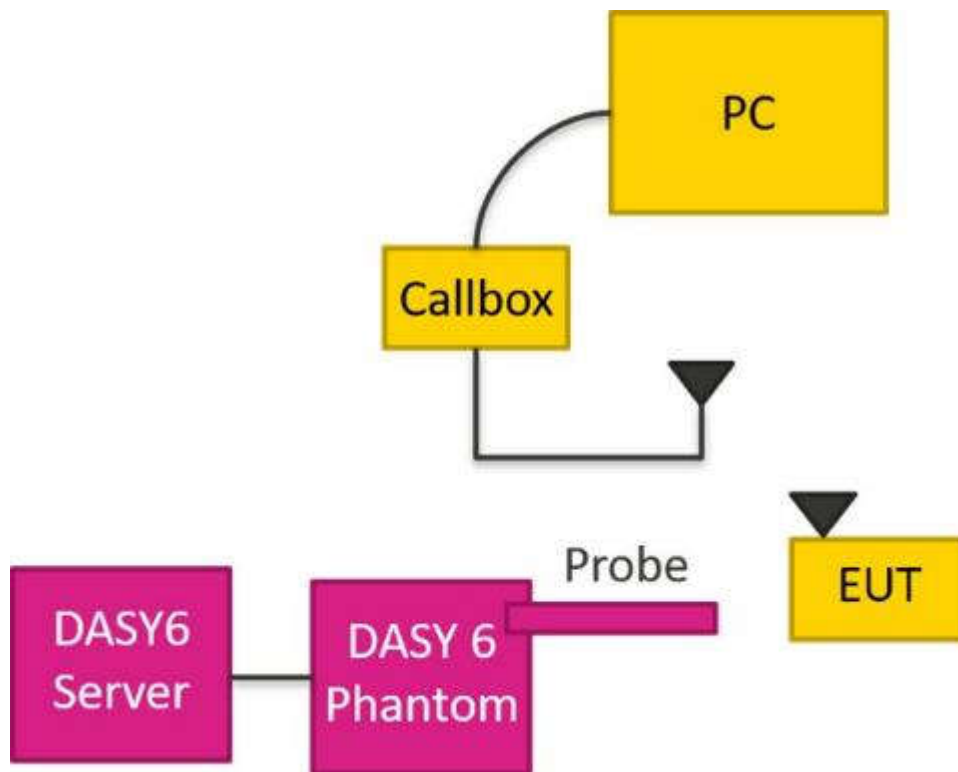

Figure 7-1 TA-SAR wireless test environment

## 6.2 SAR Measurement Results for Scenario 2: Time-Varying TX Power

In this scenario, Mediatek’s TA-SAR Gen2 algorithm is tested under more dynamic power test sequences. The test sequence #1 is shown in section 4.1 and test sequence #2 is tabulated in table 4.4. All of the test cases for this scenario are relegated in Table 7-1, and the test procedure follows section 4.10.2. The measurement setup is shown in Figure 7-1 and Setup Photos. All of the measurements are conduct in SPORTON (i.e., an FCC certified lab) by using DASY6. The high-level summary of the final validation results is given in the last column of the table, which concludes that Mediatek’s TA-SAR Gen2 algorithm can maintain the time-averaged SAR is always below the FCC requirement for all test cases. The following sections will demonstrate case-by-case to show how Mediatek’s TA-SAR Gen2 algorithm behaves for each RAT.

**Table 7-1 Operating parameters for different TA-SAR Gen2 parameters setting**

Test case#	Test scenario	Tech	Band	Ant	SPLSR Group	EIC	Channel	Freq (MHz)	BW	RB size	RB offset	Mode	Duty cycle	Position	Position details	Plimit Setting (dBm)	Target Pmax (dBm)	Measured Plimit (dBm)	Measured Pmax (dBm)	PUE <sub>max_cust_offset</sub>	PUE <sub>backoff_offset</sub>
1	Time-varying	GSM	850	0	0	3	189	836.4	-	-	-	GPRS (4 Tx slots)	50.0%	Back	5mm	23	25.5	22.85	25.63	9	1.75
2		GSM	1900	0	0	3	810	1909.8	-	-	-	GPRS (4 Tx slots)	50.0%	Back	5mm	19	22.5	18.18	21.51	9	1.75
3		WCDMA	5	0	0	3	4233	846.6	-	-	-	RMC 12.2Kbps	100.0%	Back	5mm	21	23	20.55	23.55	3	1.75
4		WCDMA	2	0	0	3	9538	1907.6	-	-	-	RMC 12.2Kbps	100.0%	Back	5mm	17.5	23	16.5	23.01	3	1.75
5		LTE	26	4	1	3	26965	841.5	15	1	0	QPSK	100.0%	Back	5mm	22.2	23	22.26	23.03	3	1.75
6		LTE	66	4	1	7	132322	1745	20	1	0	QPSK	100.0%	Top Side	5mm	13	23	12.66	22.56	3	1.75
7		5G NR	n26	4	1	3	166300	831.5	20	50	28	DFT-15,QPSK	100.0%	Back	5mm	22	23	21.69	22.73	3	1.75
8		5G NR	n41	4	1	7	518598	2592.99	100	1	1	DFT-30,QPSK	100.0%	Top Side	5mm	12.5	26	11.55	25.2	3	1.75

### 6.2.1 SAR Measurement results for 2G

- Case1-1: 2G GSM850 result for test sequence 1

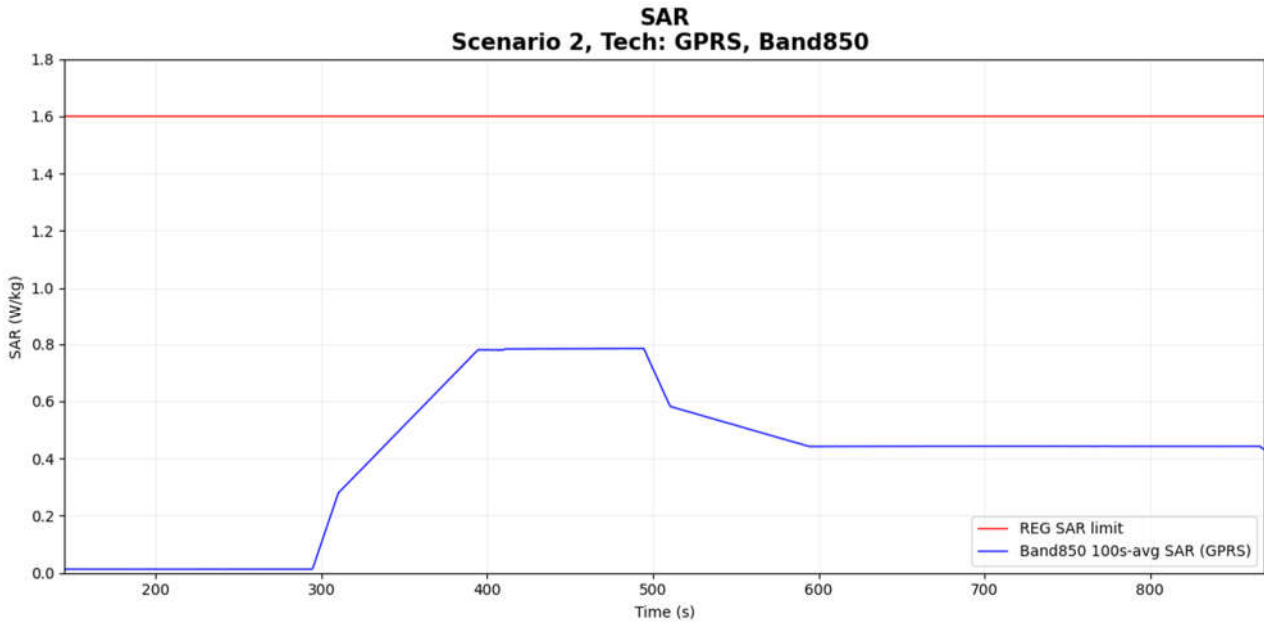

Figure 7-2 Time-averaged SAR

FCC 1gSAR limit	1.6 W/kg
Max time averaged 1gSAR	0.785 W/kg
Validation result: <span style="color: green;">pass</span>	

● Case1-2: GSM850 result for test sequence 2

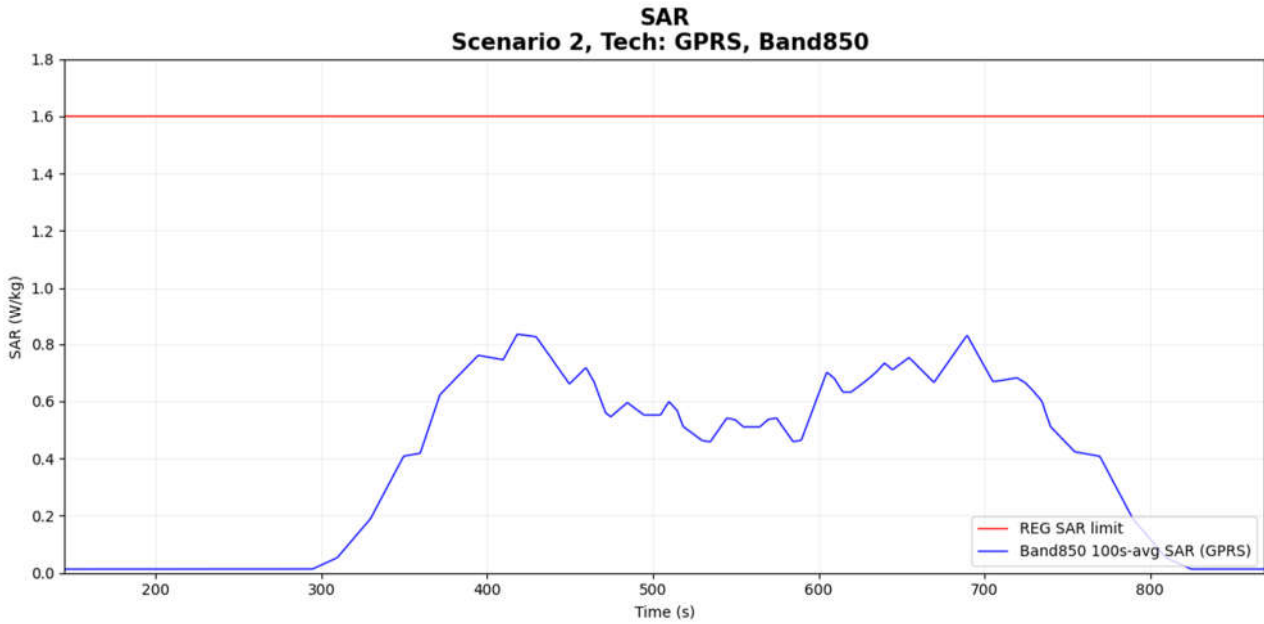

Figure 7-3 Time-averaged SAR

FCC 1gSAR limit	1.6 W/kg
Max time averaged 1gSAR	0.835 W/kg
Validation result: <span style="color: green;">pass</span>	

- Case2-1: 2G GSM1900 result for test sequence 1

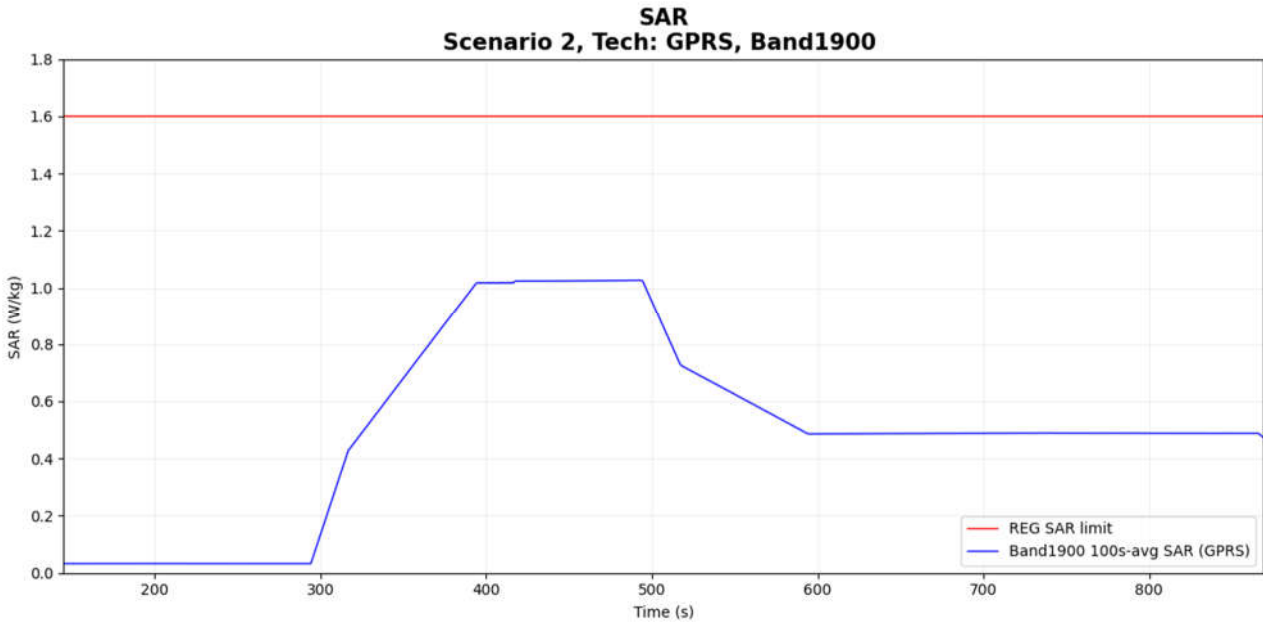

Figure 7-4 Time-averaged SAR

FCC 1gSAR limit	1.6 W/kg
Max time averaged 1gSAR	1.027 W/kg
Validation result: <span style="color: green;">pass</span>	

- Case2-2: GSM1900 result for test sequence 2

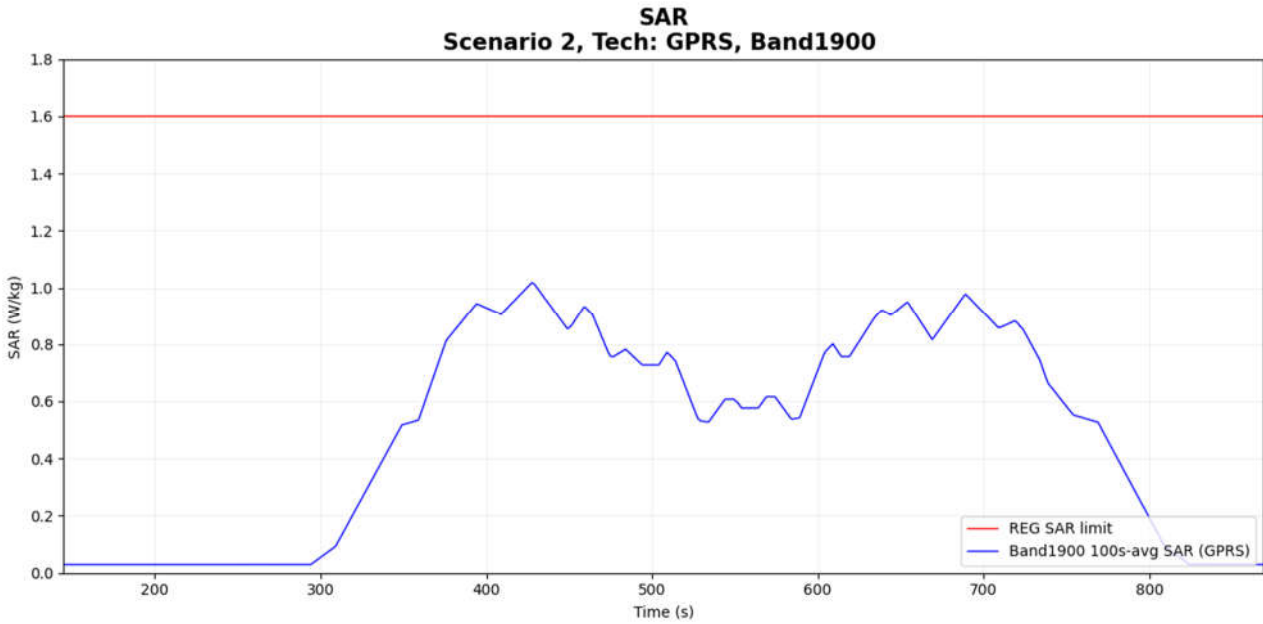

Figure 7-5 Time-averaged SAR

FCC 1gSAR limit	1.6 W/kg
Max time averaged 1gSAR	1.017 W/kg
Validation result: <span style="color: green;">pass</span>	

### 6.2.2 SAR Measurement results for 3G

- Case3-1: WCDMA B5 result for test sequence 1

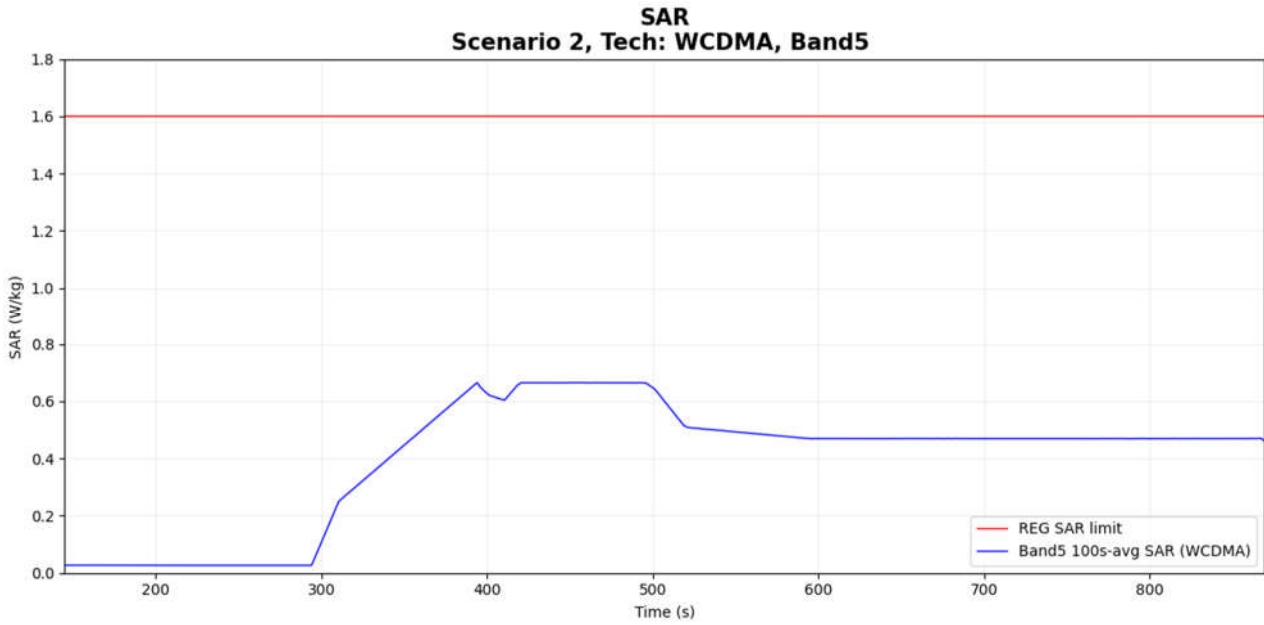

Figure 7-6 Time-averaged SAR

FCC 1gSAR limit	1.6 W/kg
Max time averaged 1gSAR	0.666 W/kg
Validation result: <span style="color: green;">pass</span>	

● Case3-2: WCDMA B5 result for test sequence 2

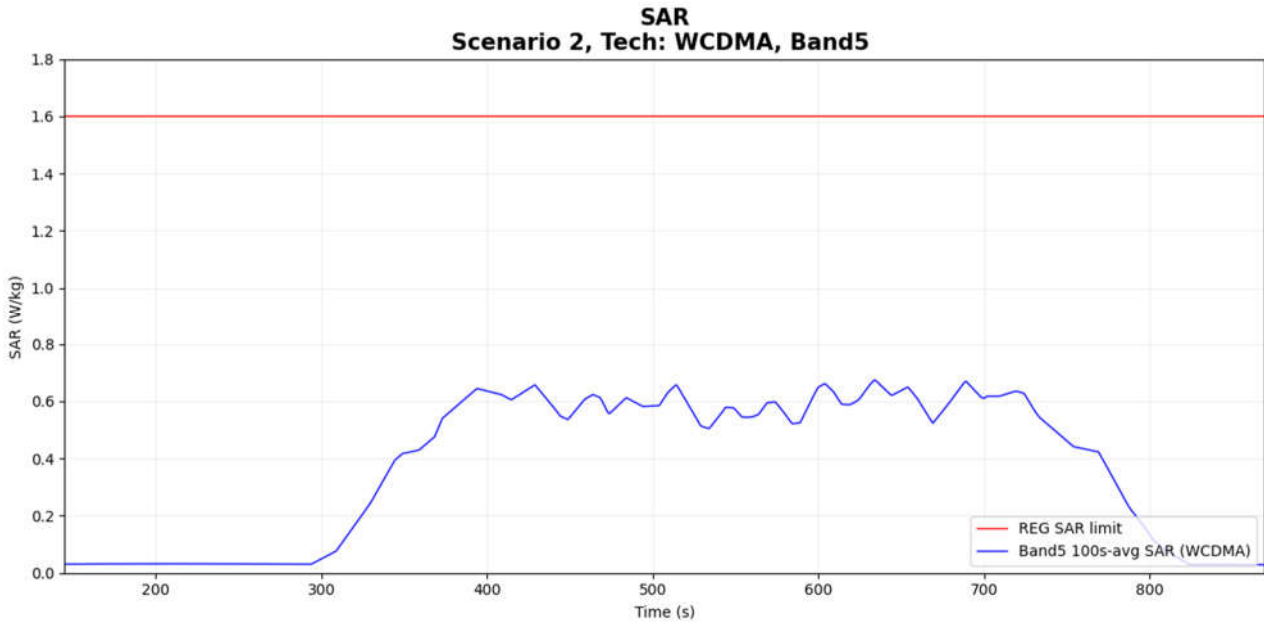

Figure 7-7 Time-averaged SAR

FCC 1gSAR limit	1.6 W/kg
Max time averaged 1gSAR	0.674 W/kg
Validation result: <span style="color: green;">pass</span>	

● Case4-1: WCDMA B2 result for test sequence 1

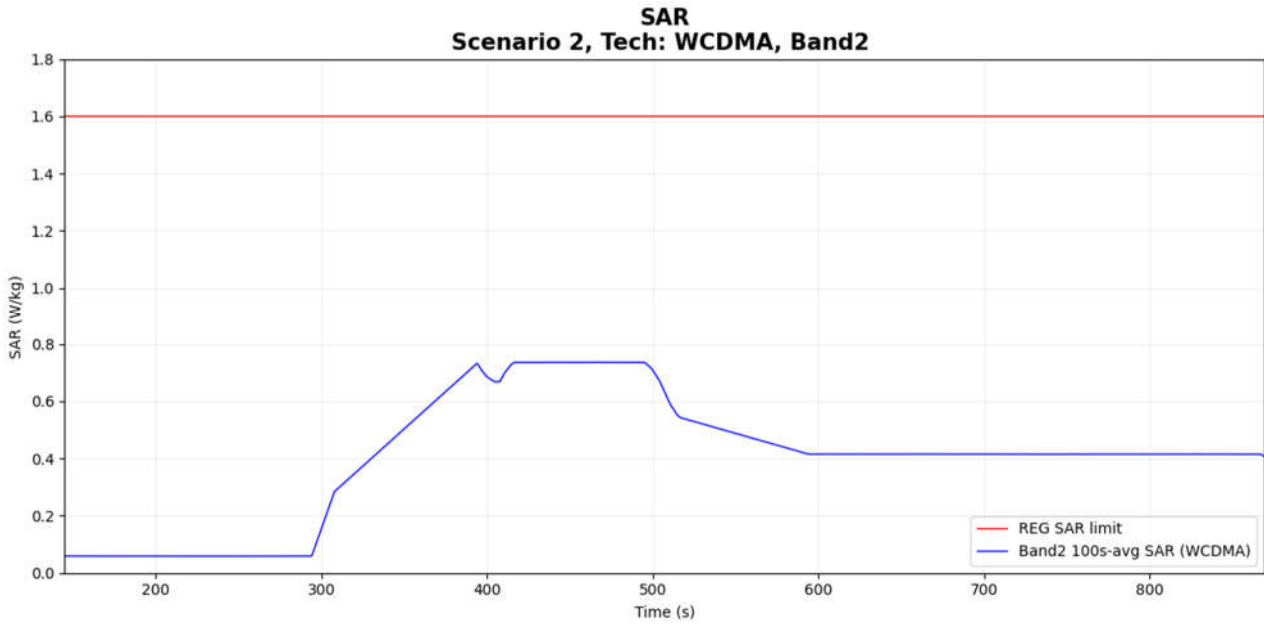

Figure 7-8 Time-averaged SAR

FCC 1gSAR limit	1.6 W/kg
Max time averaged 1gSAR	0.737 W/kg
Validation result: <span style="color: green;">pass</span>	

● Case4-2: WCDMA B2 result for test sequence 2

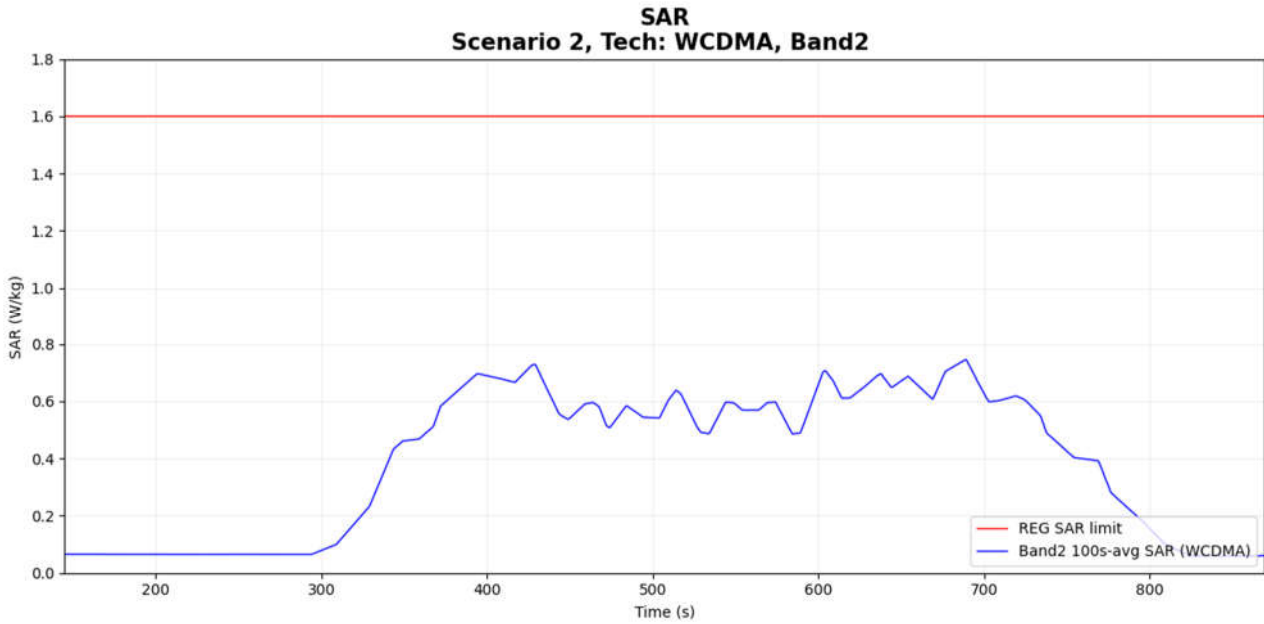

Figure 7-9 Time-averaged SAR

FCC 1gSAR limit	1.6 W/kg
Max time averaged 1gSAR	0.746 W/kg
Validation result: <span style="color: green;">pass</span>	

### 6.2.3 SAR Measurement results for LTE

- Case5-1: LTE Band 26 result for test sequence 1

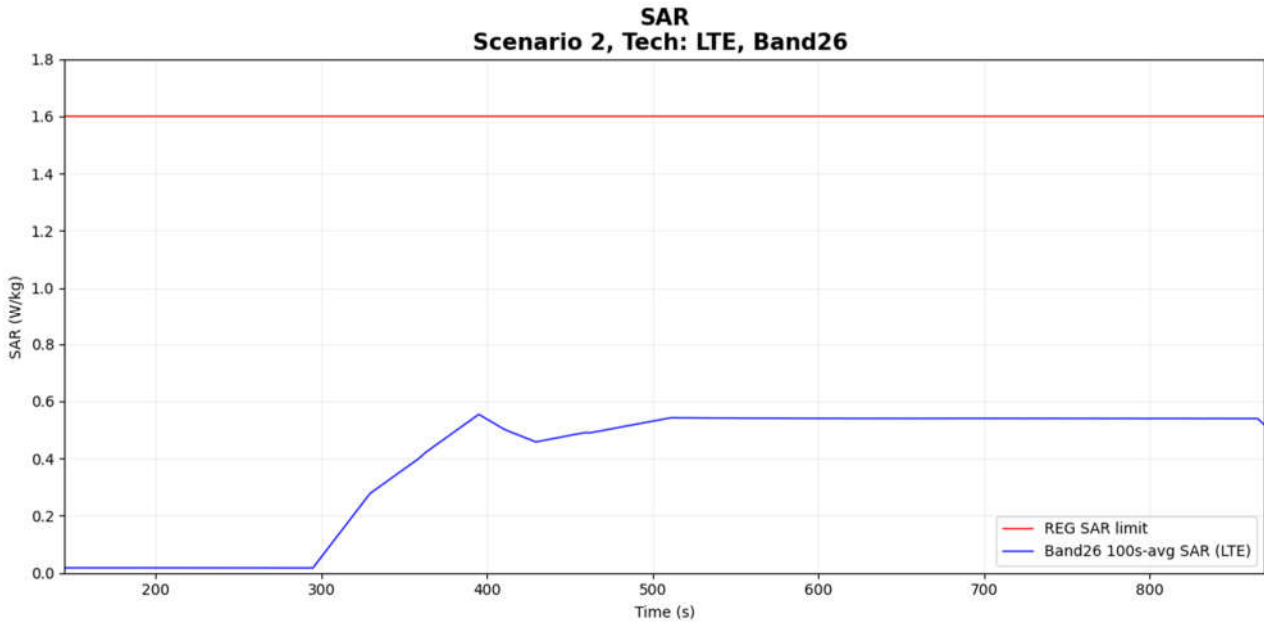

Figure 7-10 Time-averaged SAR

FCC 1gSAR limit	1.6 W/kg
Max time averaged 1gSAR	0.554 W/kg
Validation result: <span style="color: green;">pass</span>	

- Case5-2: LTE Band 26 result for test sequence 2

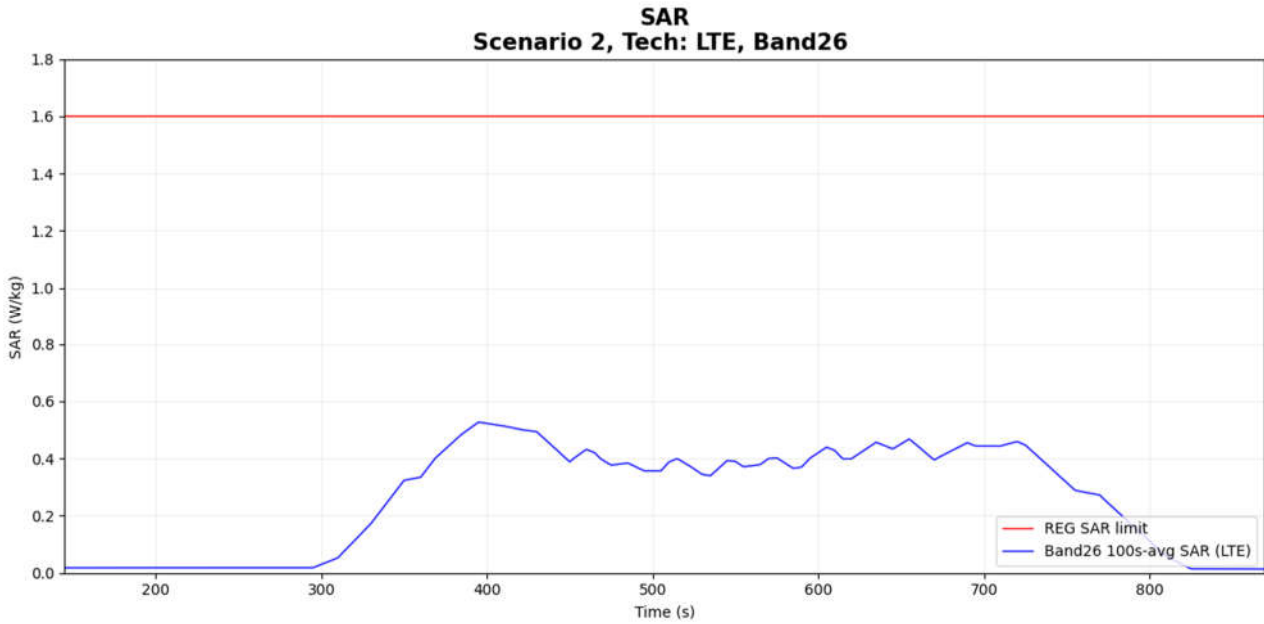

Figure 7-11 Time-averaged SAR

FCC 1gSAR limit	1.6 W/kg
Max time averaged 1gSAR	0.527 W/kg
Validation result: <span style="color: green;">pass</span>	

- Case6-1: LTE Band 66 result for test sequence 1

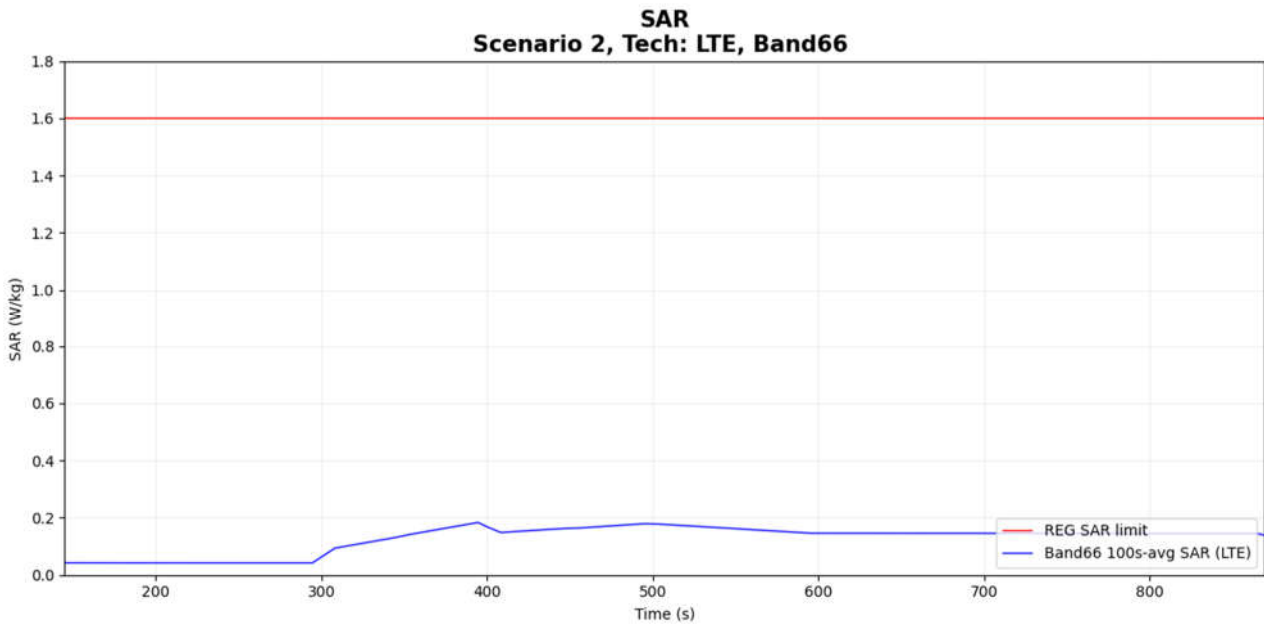

Figure 7-12 Time-averaged SAR

FCC 1gSAR limit	1.6 W/kg
Max time averaged 1gSAR	0.183 W/kg
Validation result: <span style="color: green;">pass</span>	

- Case6-2: LTE Band 66 result for test sequence 2

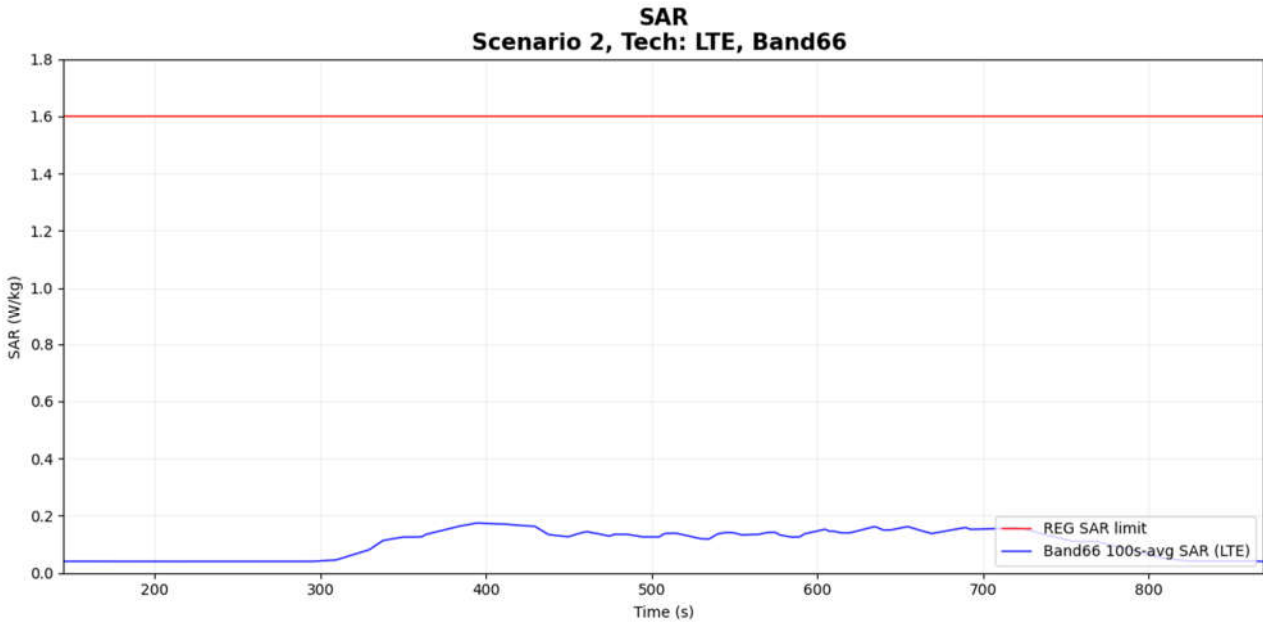

Figure 7-13 Time-averaged SAR

FCC 1gSAR limit	1.6 W/kg
Max time averaged 1gSAR	0.175 W/kg
Validation result: <span style="color: green;">pass</span>	

### 6.2.4 SAR Measurement results for NR

- Case7-1: NR n26 result for test sequence 1

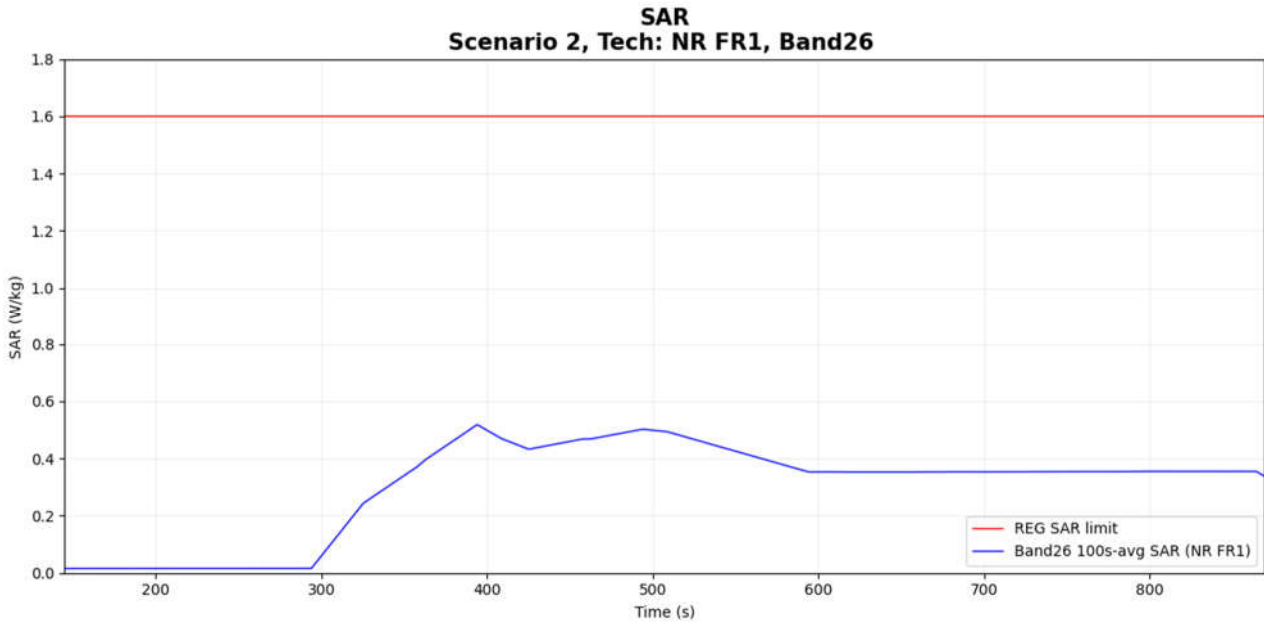

Figure 7-14 Time-averaged SAR

FCC 1gSAR limit	1.6 W/kg
Max time averaged 1gSAR	0.518 W/kg
Validation result: <span style="color: green;">pass</span>	

- Case7-2: NR n26 result for test sequence 2

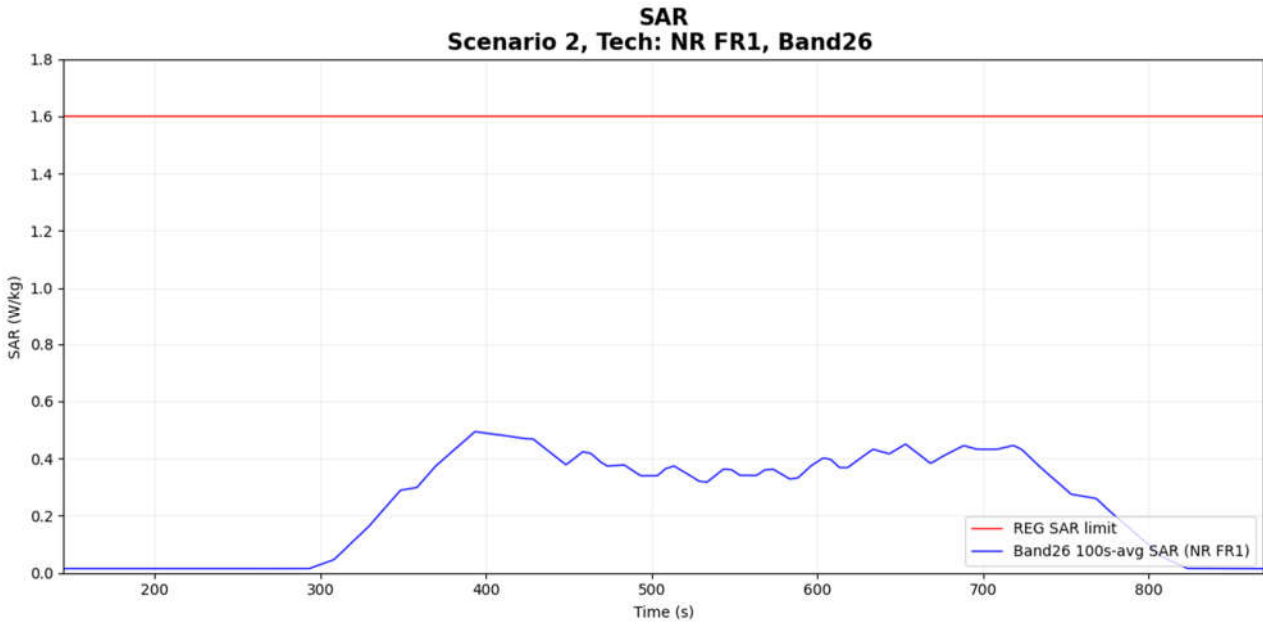

Figure 7-15 Time-averaged SAR

FCC 1gSAR limit	1.6 W/kg
Max time averaged 1gSAR	0.494 W/kg
Validation result: <span style="color: green;">pass</span>	

- Case8-1: NR n41 result for test sequence 1

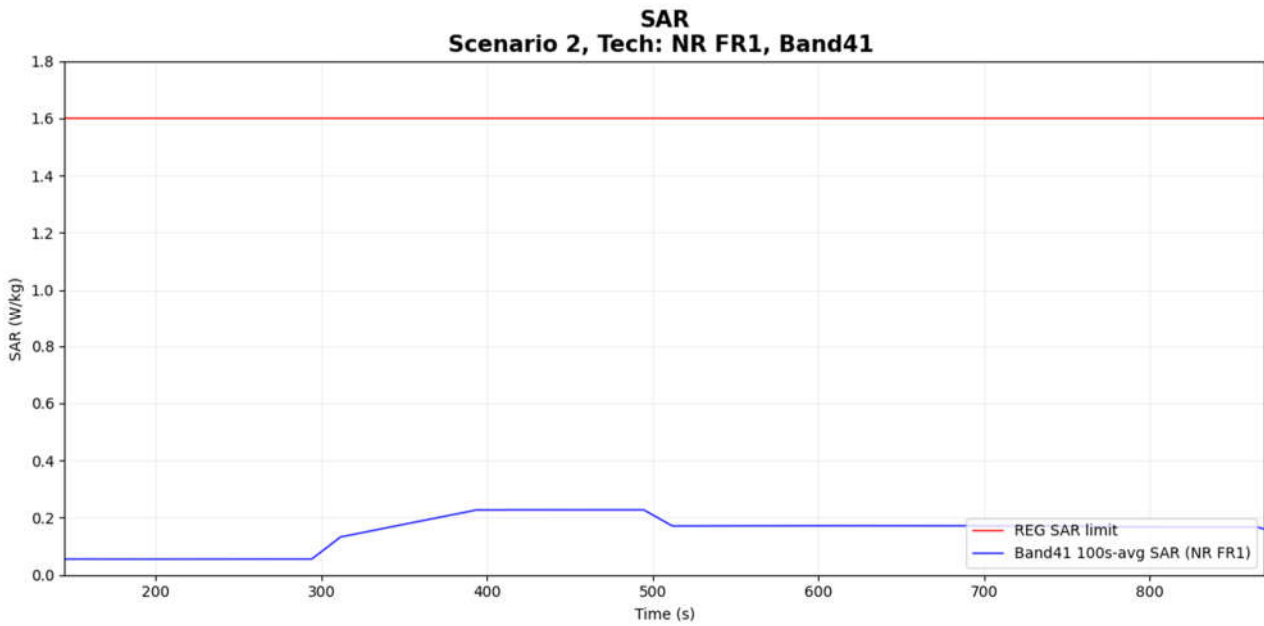

Figure 7-16 Time-averaged SAR

FCC 1gSAR limit	1.6 W/kg
Max time averaged 1gSAR	0.228 W/kg
Validation result: <span style="color: green;">pass</span>	

- Case8-2: NR n41 result for test sequence 2

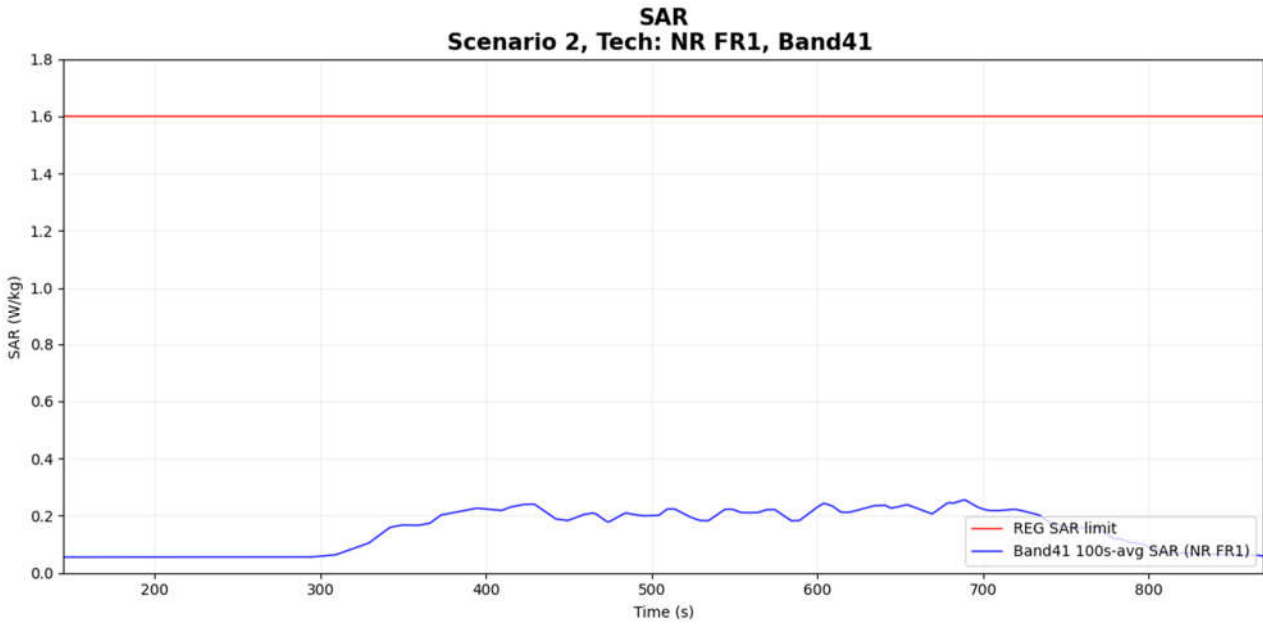

Figure 7-17 Time-averaged SAR for case

FCC 1gSAR limit	1.6 W/kg
Max time averaged 1gSAR	0.258 W/kg
Validation result: <span style="color: green;">pass</span>	



## **7. Conclusions**

This document proposes TA-SAR test scenarios and procedures, and further proves Mediatek's TA-SAR Gen2 algorithms can meet the FCC SAR regulations with the proposed test scenarios and procedures. As shown in Chapters 5, Mediatek's TA-SAR Gen2 algorithms are able to maintain SAR over time below the FCC regulatory limits (based on the agreed TX-power-to-SAR translation). Furthermore, the near-field measurements are also done in an FCC certified lab (i.e., SPORTON) to further validate the proposed test methodologies, and the results shown in Chapters 6 demonstrate that Mediatek's TA-SAR Gen2 algorithms really can maintain SAR over time below the FCC regulatory limits under the proposed test procedures. Based on the provided measurement evidences, it is concluded that Mediatek's TA-SAR Gen2 algorithms can be tested by using the proposed test methodology for FCC compliance.

## 8. cDASY6 System Verification

### 8.1 The system to be used for the near field power density measurement

- SPEAG DASY6 system
- SPEAG cDASY6 5G module software
- EUmmWVx probe
- 5G Phantom cover
- SAR phantom (SAM-Twin/ELI Phantom)
- SAR probe (EX3D, ES3D probes)

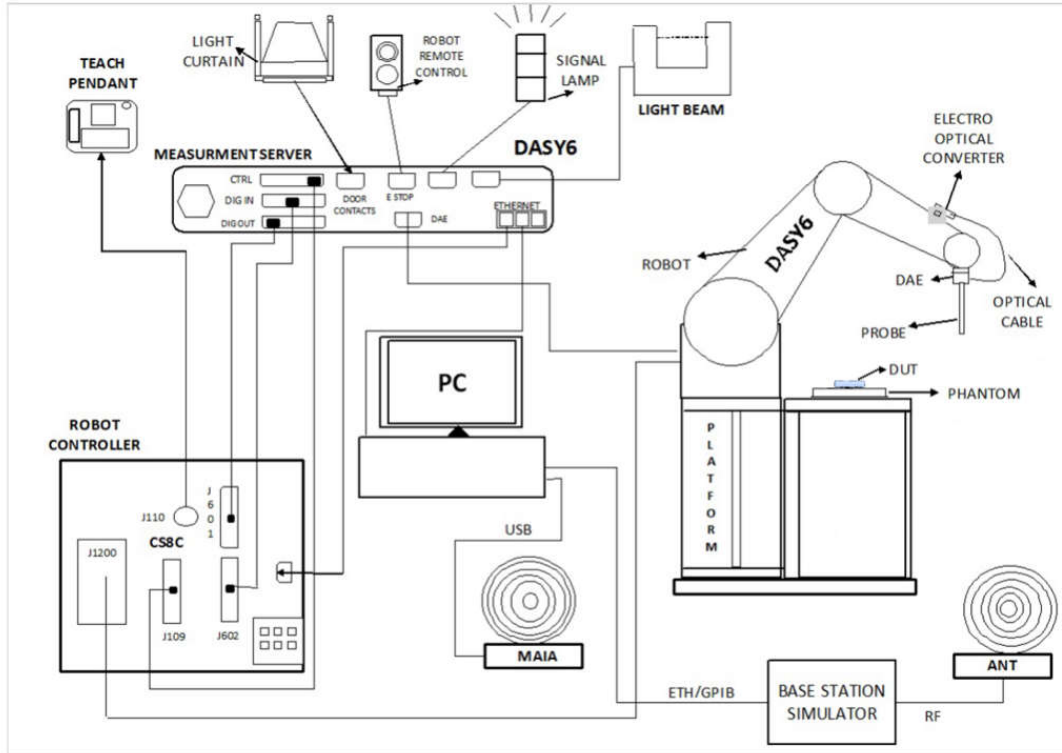

### 8.2 Test Side Location

Sporton International Inc. (Shenzhen) is accredited to ISO/IEC 17025:2017 by American Association for Laboratory Accreditation with Certificate Number 5145.01.

Testing Laboratory			
Test Firm	Sporton International Inc. (Shenzhen)		
Test Site Location	1/F, 2/F, Bldg 5, Shiling Industrial Zone, Xinwei Village, Xili, Nanshan, Shenzhen, 518055 People's Republic of China TEL: +86-755-86379589 FAX: +86-755-86379595		
Test Site No.	Sporton Site No.	FCC Designation No.	FCC Test Firm Registration No.
	SAR02-SZ	CN1256	421272

### 8.3 SAR E-Field Probe

<b>Construction</b>	Symmetric design with triangular core Built-in shielding against static charges PEEK enclosure material (resistant to organic solvents, e.g., DGBE)	
<b>Frequency</b>	4 MHz – >10 GHz Linearity: $\pm 0.2$ dB (30 MHz – 10 GHz)	
<b>Directivity</b>	$\pm 0.3$ dB in TSL (rotation around probe axis) $\pm 0.5$ dB in TSL (rotation normal to probe axis)	
<b>Dynamic Range</b>	10 $\mu$ W/g – >100 mW/g Linearity: $\pm 0.2$ dB (noise: typically <1 $\mu$ W/g)	
<b>Dimensions</b>	Overall length: 337 mm (tip: 20 mm) Tip diameter: 2.5 mm (body: 12 mm) Typical distance from probe tip to dipole centers: 1 mm	

### 8.4 Data Acquisition Electronics (DAE)

The data acquisition electronics (DAE) consists of a highly sensitive electrometer-grade preamplifier with auto-zeroing, a channel and gain-switching multiplexer, a fast 16 bit AD-converter and a command decoder and control logic unit. Transmission to the measurement server is accomplished through an optical downlink for data and status information as well as an optical uplink for commands and the clock.

The input impedance of the DAE is 200 MOhm; the inputs are symmetrical and floating. Common mode rejection is above 80 dB.

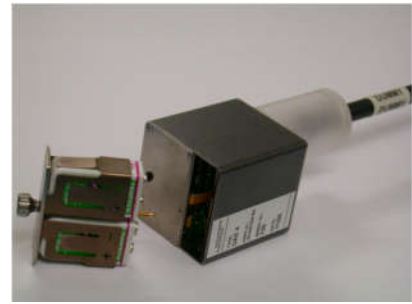

### 9. Test Equipment List

Manufacturer	Name of Equipment	Type/Model	Serial Number	Calibration	
				Last Cal.	Due Date
SPEAG	835MHz System Validation Kit	D835V2	4d162	Dec. 13, 2024	Dec. 12, 2025
SPEAG	1750MHz System Validation Kit	D1750V2	1137	Oct. 15, 2024	Oct. 14, 2025
SPEAG	1900MHz System Validation Kit	D1900V2	5d182	Dec. 16, 2024	Dec. 15, 2025
SPEAG	2600MHz System Validation Kit	D2600V2	1070	Dec. 13, 2024	Dec. 12, 2025
SPEAG	Data Acquisition Electronics	DAE4	1386	Aug. 30, 2024	Aug. 29, 2025
SPEAG	Dosimetric E-Field Probe	EX3DV4	3819	Aug. 22, 2024	Aug. 21, 2025
SPEAG	SAM Twin Phantom	QD 000 P40 CD	1670	NCR	NCR
SPEAG	Phone Positioner	N/A	N/A	NCR	NCR
R&S	Wideband Radio Communication Tester	CMW500	157651	Dec. 26, 2024	Dec. 25, 2025
Keysight	5G Wireless Test Platform	E7515B	MY59321532	Aug. 14, 2024	Aug. 13, 2025
Keysight	5G Wireless Test Platform	E7515B	MY59321532	Jul. 03, 2025	Jul. 02, 2026
Keysight	Network Analyzer	E5071C	MY46523671	Oct. 15, 2024	Oct. 14, 2025
Speag	Dielectric Assessment KIT	DAK-3.5	1144	Aug. 20, 2024	Aug. 19, 2025
Agilent	Signal Generator	N5181A	MY50145381	Dec. 26, 2024	Dec. 25, 2025
Anritsu	Power Sensor	MA2411B	1306099	Oct. 15, 2024	Oct. 14, 2025
Anritsu	Power Meter	ML2495A	1349001	Oct. 15, 2024	Oct. 14, 2025
R&S	Power Sensor	NRP50S	101548	Jan. 15, 2025	Jan. 14, 2026
R&S	Power Sensor	NRP8S	109228	Apr. 01, 2025	Mar. 31, 2026
TES	Hygrometer	1310	200305411	Jan. 02, 2025	Jan. 01, 2026
Anymetre	Thermo-Hygrometer	JR593	2015030903	Dec. 28, 2024	Dec. 27, 2025
AR	Amplifier	5S1G4	0333096	Apr. 01, 2025	Mar. 31, 2026
Mini-Circuits	Amplifier	ZVE-3W-83+	599201528	Apr. 01, 2025	Mar. 31, 2026
SPEAG	Device Holder	N/A	SPEAG	N/A	N/A
TRM	Directional Coupler	DCS1070	50021-1	Note 1	
TRM	Directional Coupler	DCS1070	50021-2	Note 1	
PE	Directional Coupler	2214-10	53919	Note 1	
Jinkexinhua	Attenuator	10db-8G	N/A	Note 1	
AGILENT	Directional Coupler	0955-0148	116232-1	Note 1	
AGILENT	Directional Coupler	0955-0148	116232-2	Note 1	
AGILENT	Attenuator	8494B	MY42148574	Note 1	

**General Note:**

1. Prior to system verification and validation, the path loss from the signal generator to the system check source and the power meter, which includes the amplifier, cable, attenuator and directional coupler, was measured by the network analyzer. The reading of the power meter was offset by the path loss difference between the path to the power meter and the path to the system check source to monitor the actual power level fed to the system check source.
2. The dipole calibration interval can be extended to 3 years with justification according to KDB 865664 D01. The dipoles are also not physically damaged, or repaired during the interval. The justification data in appendix B can be found which the return loss is < -20dB, within 20% of prior calibration, the impedance is within 5 ohm of prior calibration for each dipole.



## 10. System verification and validation

### 10.1 Tissue Verification

The tissue dielectric parameters of tissue-equivalent media used for SAR measurements must be characterized within a temperature range of 18°C to 25°C, measured with calibrated instruments and apparatuses, such as network analyzers and temperature probes. The temperature of the tissue-equivalent medium during SAR measurement must also be within 18°C to 25°C and within ± 2°C of the temperature when the tissue parameters are characterized. The tissue dielectric measurement system must be calibrated before use. The dielectric parameters must be measured before the tissue-equivalent medium is used in a series of SAR measurements.

The liquid tissue depth was at least 15cm in the phantom for all SAR testing

#### <Tissue Check Results>

Frequency (MHz)	Tissue Type	Liquid Temp. (°C)	Conductivity (σ)	Permittivity (εr)	Conductivity Target (σ)	Permittivity Target (εr)	Delta (σ) (%)	Delta (εr) (%)	Limit (%)	Date
835	Head	22.4	0.918	43.500	0.90	41.50	2.00	4.82	±5	2025/7/10
1750	Head	22.6	1.350	41.600	1.37	40.10	-1.46	3.74	±5	2025/7/10
1900	Head	22.5	1.410	41.300	1.40	40.00	0.71	3.25	±5	2025/7/10
2600	Head	22.4	1.970	40.900	1.96	39.00	0.51	4.87	±5	2025/7/10

### 10.2 System Verification

Comparing to the original SAR value provided by SPEAG, the verification data should be within its specification of 10 %. Below table shows the target SAR and measured SAR after normalized to 1W input power. The table below indicates the system performance check can meet the variation criterion and the plots can be referred to Appendix A.

#### <System Verification Results>

Date	Frequency (MHz)	Tissue Type	Input Power (mW)	Dipole S/N	Probe S/N	DAE S/N	Measured 1g SAR (W/kg)	Targeted 1g SAR (W/kg)	Normalized 1g SAR (W/kg)	Deviation (%)	Measured 10g SAR (W/kg)	Targeted 10g SAR (W/kg)	Normalized 10g SAR (W/kg)	Deviation (%)
2025/7/10	835	Head	250	4d162	3819	1386	2.380	9.080	9.52	4.85	1.570	5.850	6.28	7.35
2025/7/10	1750	Head	250	1137	3819	1386	9.020	36.800	36.08	-1.96	4.850	19.600	19.4	-1.02
2025/7/10	1900	Head	250	5d182	3819	1386	10.500	39.800	42	5.53	5.450	21.000	21.8	3.81
2025/7/10	2600	Head	250	1070	3819	1386	13.800	56.500	55.2	-2.30	6.200	25.200	24.8	-1.59

## 11. Uncertainty Assessment

Declaration of Conformity:

The test results with all measurement uncertainty excluded is presented in accordance with the regulation limits or requirements declared by manufacturers.

Comments and Explanations:

The declared of product specification for EUT presented in the report are provided by the manufacturer, and the ufacturer takes all the responsibilities for the accuracy of product specification.

The component of uncertainly may generally be categorized according to the methods used to evaluate them. The evaluation of uncertainly by the statistical analysis of a series of observations is termed a Type An evaluation of uncertainty. The evaluation of uncertainty by means other than the statistical analysis of a series of observation is termed a Type B evaluation of uncertainty. Each component of uncertainty, however evaluated, is represented by an estimated standard deviation, termed standard uncertainty, which is determined by the positive square root of the estimated variance.

A Type A evaluation of standard uncertainty may be based on any valid statistical method for treating data. This includes calculating the standard deviation of the mean of a series of independent observations; using the method of least squares to fit a curve to the data in order to estimate the parameter of the curve and their standard deviations; or carrying out an analysis of variance in order to identify and quantify random effects in certain kinds of measurement.

A type B evaluation of standard uncertainty is typically based on scientific judgment using all of the relevant information available. These may include previous measurement data, experience, and knowledge of the behavior and properties of relevant materials and instruments, manufacture’s specification, data provided in calibration reports and uncertainties assigned to reference data taken from handbooks. Broadly speaking, the uncertainty is either obtained from an outdoor source or obtained from an assumed distribution, such as the normal distribution, rectangular or triangular distributions indicated in table below.

Uncertainty Distributions	Normal	Rectangular	Triangular	U-Shape
Multi-plying Factor <sup>(a)</sup>	1/ $\kappa$ <sup>(b)</sup>	1/ $\sqrt{3}$	1/ $\sqrt{6}$	1/ $\sqrt{2}$

(a) standard uncertainty is determined as the product of the multiplying factor and the estimated range of variations in the measured quantity

(b)  $\kappa$  is the coverage factor

### Standard Uncertainty for Assumed Distribution

The combined standard uncertainty of the measurement result represents the estimated standard deviation of the result. It is obtained by combining the individual standard uncertainties of both Type A and Type B evaluation using the usual “root-sum-squares” (RSS) methods of combining standard deviations by taking the positive square root of the estimated variances.

Expanded uncertainty is a measure of uncertainty that defines an interval about the measurement result within which the measured value is confidently believed to lie. It is obtained by multiplying the combined standard uncertainty by a coverage factor. Typically, the coverage factor ranges from 2 to 3. Using a coverage factor allows the true value of a measured quantity to be specified with a defined probability within the specified uncertainty range. For purpose of this document, a coverage factor two is used, which corresponds to confidence interval of about 95 %. The DASY uncertainty Budget is shown in the following tables.

The judgment of conformity in the report is based on the measurement results excluding the measurement uncertainty.

Uncertainty Budget (Frequency band: 4 MHz - 10 GHz range)							
Error Description	Uncert. Value (±%)	Prob. Dist.	Div.	(Ci) 1g	(Ci) 10g	Standard Uncertainty (1g) (±%)	Standard Uncertainty (10g) (±%)
<b>Measurement System errors</b>							
Probe calibration	18.6	N	2	1	1	9.3	9.3
Probe calibration drift	1.7	R	1.732	1	1	1.0	1.0
Probe linearity and detection Limit	4.7	R	1.732	1	1	2.7	2.7
Broadband signal	2.8	R	1.732	1	1	1.6	1.6
Probe isotropy	7.6	R	1.732	1	1	4.4	4.4
Other probe and data acquisition errors	2.4	N	1	1	1	2.4	2.4
RF ambient and noise	1.8	N	1	1	1	1.8	1.8
Probe positioning errors	0.006	N	1	0.5	0.5	0.0	0.0
Data processing errors	4.0	N	1	1	1	4.0	4.0
<b>Phantom and Device Errors</b>							
Measurement of phantom conductivity ( $\sigma$ )	2.5	N	1	0.78	0.71	2.0	1.8
Temperature effects (medium)	5.4	R	1.732	0.78	0.71	2.4	2.2
Shell permittivity	14.0	R	1.732	0.5	0.5	4.0	4.0
Distance between the radiating element of the DUT and the phantom medium	2.0	N	1	2	2	4.0	4.0
Repeatability of positioning the DUT or source against the phantom	1.0	N	1	1	1	1.0	1.0
Device holder effects	3.6	N	1	1	1	3.6	3.6
Effect of operating mode on probe sensitivity	2.4	R	1.732	1	1	1.4	1.4
Time-average SAR	1.7	R	1.732	1	1	1.0	1.0
Variation in SAR due to drift in output of DUT	2.5	N	1	1	1	2.5	2.5
Validation antenna uncertainty (validation measurement only)	0.0	N	1	1	1	0.0	0.0
Uncertainty in accepted power (validation measurement only)	0.0	N	1	1	1	0.0	0.0
<b>Correction to the SAR results</b>							
Phantom deviation from target ( $\epsilon', \sigma$ )	1.9	N	1	1	0.84	1.9	1.6
SAR scaling	0.0	R	1.732	1	1	0.0	0.0
<b>Combined Std. Uncertainty</b>						<b>14.5%</b>	<b>14.4%</b>
<b>Coverage Factor for 95 %</b>						<b>K=2</b>	<b>K=2</b>
<b>Expanded STD Uncertainty</b>						<b>29.0%</b>	<b>28.8%</b>



**Appendix A. Plots of System Performance Check**

**Appendix B. DASYS Calibration Certificate**

**Appendix C. Test Setup Photos**

-----THE END-----