



FCC RF Test Report

APPLICANT : Motorola Mobility LLC
EQUIPMENT : Mobile Cellular Phone
BRAND NAME : Motorola
MODEL NAME : XT2517-1, XT2517-2, XT2517-3, XT2517V
FCC ID : IHDT56AT8
STANDARD : 47 CFR Part 96
CLASSIFICATION : Citizens Band End User Devices (CBE)
EQUIPMENT TYPE : End User Equipment
TEST DATE(S) : Nov. 12, 2024 ~ Dec. 07, 2024

We, Sporton International Inc. (KunShan), would like to declare that the tested sample has been evaluated in accordance with the procedures given in ANSI C63.26-2015 and shown compliance with the applicable technical standards.

This report contains data that were produced under subcontract by Sporton International Inc. (ShenZhen).

The test results in this report apply exclusively to the tested model / sample. Without written approval of Sporton International Inc. (KunShan), the test report shall not be reproduced except in full.

Jason Jia



Approved by: Jason Jia

Sporton International Inc. (Kunshan)

**No. 1098, Pengxi North Road, Kunshan Economic Development Zone Jiangsu Province 215300
People's Republic of China**



Table of Contents

History of this test report..... 3

Summary of Test Result..... 4

1 General Description 5

 1.1 Applicant..... 5

 1.2 Manufacturer 5

 1.3 Feature of Equipment Under Test..... 5

 1.4 Maximum EIRP Power and Emission Designator 6

 1.5 Testing Location 7

 1.6 Test Software 7

 1.7 Applied Standards 8

 1.8 Specification of Accessory 8

2 Test Configuration of Equipment Under Test 9

 2.1 Test Mode..... 9

 2.2 Connection Diagram of Test System 10

 2.3 Support Unit used in test configuration 11

 2.4 Measurement Results Explanation Example 11

 2.5 Frequency List of Low/Middle/High Channels..... 11

3 Conducted Test Items 14

 3.1 Measuring Instruments..... 14

 3.2 Test Setup 14

 3.3 Conducted Output Power 15

 3.4 EIRP 17

 3.5 Occupied Bandwidth 18

 3.6 Conducted Band Edge 19

 3.7 Conducted Spurious Emission 20

 3.8 Frequency Stability..... 21

4 Radiated Test Items 22

 4.1 Measuring Instruments..... 22

 4.2 Test Setup 22

 4.3 Test Result of Radiated Test..... 23

 4.4 Radiated Spurious Emission 24

5 List of Measuring Equipment..... 25

6 Measurement Uncertainty 26

Appendix A. Test Results of Conducted Test

Appendix B. Test Results of Radiated Test

Appendix C. Test Setup Photographs



Summary of Test Result

Report Clause	Ref Std. Clause	Test Items	Result (PASS/FAIL)	Remark
3.3	§2.1046	Conducted Output Power	Reporting only	-
-	§96.41	Peak-to-Average Ratio	Not Applicable	Not applicable for End User Devices
3.4	§96.41	Maximum E.I.R.P	Pass	-
		Maximum Power Spectral Density	Not Applicable	Not applicable for End User Devices
3.5	§2.1049 §96.41	Occupied Bandwidth	Reporting only	-
3.6	§2.1051 §96.41	Conducted Band Edge Measurement Adjacent Channel Leakage Ratio	Pass	-
3.7	§2.1051 §96.41	Conducted Spurious Emission	Pass	
3.8	§2.1055	Frequency Stability for Temperature & Voltage	Pass	-
4.4	§2.1051 §96.41	Radiated Spurious Emission	Pass	Under limit 3.11 dB at 7104.00 MHz

Conformity Assessment Condition:
1. The test results (PASS/FAIL) with all measurement uncertainty excluded are presented against the regulation limits or in accordance with the requirements stipulated by the applicant/manufacturer who shall bear all the risks of non-compliance that may potentially occur if measurement uncertainty is taken into account.
2. The measurement uncertainty please refer to each test result in the section "Measurement Uncertainty"
Disclaimer:
The product specifications of the EUT presented in the test report that may affect the test assessments are declared by the manufacturer who shall take full responsibility for the authenticity.



1 General Description

1.1 Applicant

Motorola Mobility LLC
222 W,Merchandise Mart Plaza, Chicago IL 60654 USA

1.2 Manufacturer

Motorola Mobility LLC
222 W,Merchandise Mart Plaza, Chicago IL 60654 USA

1.3 Feature of Equipment Under Test

Product Feature	
Equipment	Mobile Cellular Phone
Brand Name	Motorola
Model Name	XT2517-1, XT2517-2, XT2517-3, XT2517V
FCC ID	IHDT56AT8
Tx Frequency	LTE Band 48: 3550 MHz ~ 3700 MHz
Rx Frequency	LTE Band 48: 3550 MHz ~ 3700 MHz
Bandwidth	5MHz / 10MHz / 15MHz / 20MHz
Maximum Output Power to Antenna	<Ant. 4>: LTE Band 48: 22.57 dBm LTE CA_48B: 23.34 dBm LTE CA_48C: 21.19 dBm <Ant. 7>: LTE Band 48: 22.39 dBm LTE CA_48B: 23.12 dBm LTE CA_48C: 20.96 dBm <Ant. 8>: LTE Band 48: 22.56 dBm LTE CA_48B: 23.66 dBm LTE CA_48C: 21.63 dBm <Ant. 9>: LTE Band 48: 23.37 dBm LTE CA_48B: 23.49 dBm LTE CA_48C: 21.45 dBm
Antenna Gain	<Ant. 4>: LTE Band 48: -0.5 dBi <Ant. 7>: LTE Band 48: -1.0 dBi <Ant. 8>: LTE Band 48: -1.0 dBi <Ant. 9>: LTE Band 48: -0.5 dBi
Type of Modulation	QPSK / 16QAM / 64QAM / 256QAM
IMEI Code	Conducted: 358926210031872 Radiation: 358926210036111
HW Version	DVT2
SW Version	VVA35.34
EUT Stage	Identical Prototype

Remark:

1. The above EUT's information was declared by manufacturer. Please refer to the specifications or



user's manual for more detailed description.

2. The four models name XT2517-1, XT2517-2, XT2517-3, XT2517V are the same product except model name different for market segment.
3. The maximum EIRP is calculated from max output power and antenna gain, only the maximum EIRP of Ant. 9 LTE B48/48B/48C are shown in the report.
4. The device supports two PAs for LTE Band 48(main PA and other PA, other PA for ENDC_48A-n5A), both the PAs are full tested, only the worst EIRP are shown in the report.
5. For LTE B48B/48C, the test data of the worse Ant.8 are shown in the report according to the maximum power for conducted test items.

1.4 Maximum EIRP Power and Emission Designator

LTE Band 48		QPSK		16QAM/64QAM/256QAM	
BW (MHz)	Frequency Range (MHz)	Maximum EIRP(W)	Emission Designator (99%OBW)	Maximum EIRP(W)	Emission Designator (99%OBW)
5	3552.5~3697.5	0.1897	4M51G7D	0.1875	4M48W7D
10	3555~3695	0.1919	9M01G7D	0.1866	9M07W7D
15	3557.5~3692.5	0.1910	13M5G7D	0.1879	13M5W7D
20	3560~3690	0.1936	17M9G7D	0.1928	17M9W7D

LTE Band 48B_CA		QPSK		16QAM/64QAM/256QAM	
BW (MHz) Frequency (MHz)		Maximum EIRP(W)	Emission Designator (99%OBW)	Maximum EIRP(W)	Emission Designator (99%OBW)
10MHz+10MHz (3555 ~ 3695 MHz)		0.1991	18M7G7D	0.1986	18M8W7D

LTE Band 48 CA		QPSK		16QAM/64QAM/256QAM	
BW (MHz) Frequency (MHz)		Maximum EIRP(W)	Emission Designator (99%OBW)	Maximum EIRP(W)	Emission Designator (99%OBW)
5MHz+20MHz (3553.5 ~ 3690 MHz)		0.1026	23M3G7D	0.1007	23M2W7D
10MHz+20MHz (3555.5 ~ 3690 MHz)		0.1178	28M0G7D	0.1156	28M0W7D
15MHz+20MHz (3557.8 ~ 3690 MHz)		0.1216	32M8G7D	0.1191	32M7W7D
20MHz+5MHz (3560 ~ 3696.7 MHz)		0.1023	23M3G7D	0.0995	23M3W7D
20MHz+10MHz (3560 ~ 3694.5 MHz)		0.1143	28M2G7D	0.1114	27M9W7D
20MHz+15MHz (3560 ~ 3692.2 MHz)		0.1225	32M7G7D	0.1205	32M9W7D
20MHz+20MHz (3560 ~ 3690 MHz)		0.1245	37M6G7D	0.1197	37M6W7D



Note: All modulations have been tested, only the worst test results of PSK & QAM are shown in the report.

1.5 Testing Location

Sporton International Inc. (Kunshan) is accredited to ISO/IEC 17025:2017 by American Association for Laboratory Accreditation with Certificate Number 5145.02.

Test Firm	Sporton International Inc. (Kunshan)		
Test Site Location	No. 1098, Pengxi North Road, Kunshan Economic Development Zone Jiangsu Province 215300 People's Republic of China TEL : +86-512-57900158		
Test Site No.	Sporton Site No.	FCC Designation No.	FCC Test Firm Registration No.
	03CH04-KS	CN1257	314309

Sporton International Inc. (ShenZhen) is accredited to ISO/IEC 17025:2017 by American Association for Laboratory Accreditation with Certificate Number 5145.01.

Test Firm	Sporton International Inc. (ShenZhen)		
Test Site Location	1/F, 2/F, Bldg 5, Shiling Industrial Zone, Xinwei Village, Xili, Nanshan, Shenzhen, 518055 People's Republic of China TEL: +86-755-86379589 FAX: +86-755-86379595		
Test Site No.	Sporton Site No.	FCC Designation No.	FCC Test Firm Registration No.
	TH01-SZ	CN1256	421272

Test data subcontracted: Conducted test case in section 3 of this report.

1.6 Test Software

Item	Site	Manufacture	Name	Version
1.	03CH04-KS	AUDIX	E3	210616



1.7 Applied Standards

According to the specifications of the manufacturer, the EUT must comply with the requirements of the following standards:

- ♦ ANSI C63.26-2015
- ♦ 47 CFR Part 96
- ♦ FCC KDB 971168 D01 Power Meas. License Digital Systems v03r01
- ♦ FCC KDB 940660 D01 Part 96 CBRS v03
- ♦ FCC KDB 412172 D01 Determining ERP and EIRP v01r01

Remark:

1. All test items were verified and recorded according to the standards and without any deviation during the test.
2. This EUT has also been tested and complied with the requirements of FCC Part 15, Subpart B, recorded in a separate test report.

1.8 Specification of Accessory

Accessories Information				
Battery 1	Brand Name	Motorola(COSMX)	Model Name	RH50
Battery 2	Brand Name	Motorola(SUNWODA)	Model Name	RH50
USB Cable 1	Brand Name	LUXSHARE	Model Name	SC18E08103
USB Cable 2	Brand Name	Saibao	Model Name	SC18D86731
Stylus	Brand Name	Techson	Model Name	SO28E49329



2 Test Configuration of Equipment Under Test

2.1 Test Mode

Antenna port conducted and radiated test items listed below are performed according to KDB 971168 D01 Power Meas. License Digital Systems v03r01 with maximum output power.

For radiated measurement, pre-scanned in three orthogonal panels, X, Y, Z. The worst cases (Y Plane) were recorded in this report.

Test Items	Band	Bandwidth (MHz)						Modulation				RB #			Test Channel			
		1.4	3	5	10	15	20	QPSK	16 QAM	64 QAM	256 QAM	1	Half	Full	L	M	H	
Max. Output Power	48	-	-	v	v	v	v	v	v	v	v	v	v	v	v	v	v	v
Adjacent Channel Leakage Ratio	48	-	-	v	v	v	v	v	v	v			v	v	v	v	v	
26dB and 99% Bandwidth	48	-	-	v	v	v	v	v	v				v		v			
Conducted Band Edge	48	-	-	v	v	v	v	v	v	v			v	v	v	v	v	
Conducted Spurious Emission	48	-	-	v	v	v	v	v					v		v	v	v	
E.I.R.P	48	-	-	v	v	v	v	v	v	v	v	v	v	v	v	v	v	
Frequency Stability	48	-	-	v				v					v			v		
Radiated Spurious Emission	48	Worst Case													v	v	v	
Remark	<ol style="list-style-type: none"> The mark "v " means that this configuration is chosen for testing The mark "- " means that this bandwidth is not supported. The device is investigated from 30MHz to 10 times of fundamental signal for radiated spurious emission test under different RB size/offset and modulations in exploratory test. Subsequently, only the worst case emissions are reported. All test items are based on engineering evaluation. 																	



Test Items	Band	Bandwidth (MHz)								Modulation			RB #			Test Channel			
		20+20	20+15	15+20	20+10	10+20	10+10	20+5	5+20	QPSK	16 QAM	64 QAM	256 QAM	1	Half	Full	L	M	H
Max. Output Power	48B	-	-	-	-	-	v	-	-	v	v	v	v	v			v	v	v
	48C	v	v	v	v	v	-	v	v	v	v	v	v	v			v	v	v
26dB and 99% Bandwidth	48B	-	-	-	-	-	v	-	-	v	v					v		v	
	48C	v	v	v	v	v	-	v	v	v	v					v		v	
Conducted Band Edge	48B	-	-	-	-	-	v	-	-	v	v	v		v		v	v	v	v
	48C	v	v	v	v	v	-	v	v	v	v	v		v		v	v	v	v
Conducted Spurious Emission	48B	-	-	-	-	-	v	-	-	v				v			v	v	v
	48C	v	v	v	v	v	-	v	v	v				v			v	v	v
Adjacent Channel Leakage Ratio	48B	-	-	-	-	-	v	-	-	v	v	v		v		v	v	v	v
	48C	v	v	v	v	v	-	v	v	v	v	v		v		v	v	v	v
E.I.R.P.	48B	-	-	-	-	-	v	-	-	v	v	v	v	v			v	v	v
	48C	v	v	v	v	v	-	v	v	v	v	v	v	v			v	v	v
Radiated Spurious Emission	48B	Worst Case															v	v	v
	48C	Worst Case															v	v	v
Note	<ol style="list-style-type: none"> The mark "v" means that this configuration is chosen for testing The mark "-" means that this bandwidth is not supported. The device is investigated from 30MHz to 10 times of fundamental signal for radiated spurious emission test under different RB size/offset and modulations in exploratory test. Subsequently, only the worst case emissions are reported. All test items are based on engineering evaluation. 																		

2.2 Connection Diagram of Test System

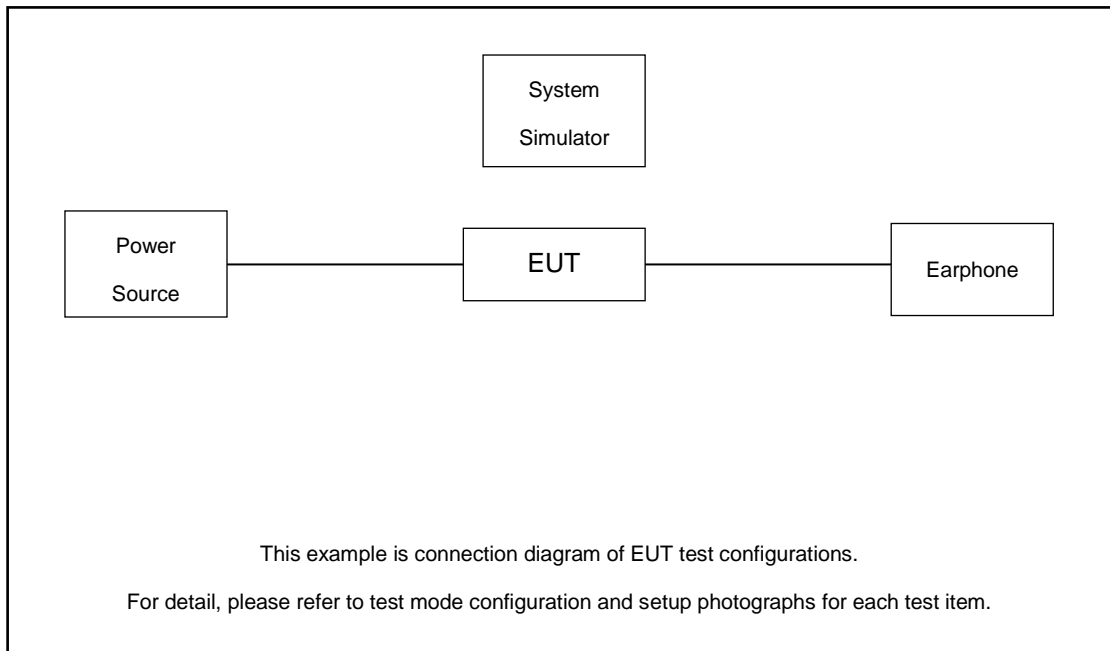



2.3 Support Unit used in test configuration

Item	Equipment	Trade Name	Model No.	FCC ID	Data Cable	Power Cord
1.	Power Supply	GWINSTEK	PSS-2002	N/A	N/A	Unshielded, 1.8 m
2.	LTE Base Station	Anritsu	MT8821C	N/A	N/A	Unshielded, 1.8 m
3.	Earphone	N/A	N/A	N/A	N/A	N/A

2.4 Measurement Results Explanation Example

For all conducted test items:

The offset level is set in the spectrum analyzer to compensate the RF cable loss and attenuator factor between EUT conducted output port and spectrum analyzer. With the offset compensation, the spectrum analyzer reading level is exactly the EUT RF output level.

The spectrum analyzer offset is derived from RF cable loss and attenuator factor.

Offset = RF cable loss + attenuator factor.

Following shows an offset computation example with cable loss 5.5 dB and 10dB attenuator.

Example :

$$\begin{aligned}
 \text{Offset(dB)} &= \text{RF cable loss(dB)} + \text{attenuator factor(dB)} \\
 &= 5.5 + 10 = 15.5 \text{ (dB)}
 \end{aligned}$$

2.5 Frequency List of Low/Middle/High Channels

LTE Band 48 Channel and Frequency List				
BW [MHz]	Channel/Frequency(MHz)	Lowest	Middle	Highest
20	Channel	55340	55990	56640
	Frequency	3560.0	3625.0	3690.0
15	Channel	55315	55990	56665
	Frequency	3557.5	3625.0	3692.5
10	Channel	55290	55990	56690
	Frequency	3555.0	3625.0	3695.0
5	Channel	55265	55990	56715
	Frequency	3552.5	3625.0	3697.5



LTE Band 48B_CA Channel and Frequency List					
BW [MHz]	Channel/Frequency(MHz)		Lowest	Middle	Highest
10 + 10	PCC	Channel	55290	55941	56591
		Frequency	3555	3620.1	3685.1
	SCC	Channel	55389	56039	56690
		Frequency	3564.9	3629.9	3695

LTE Band 48C_CA Channel and Frequency List					
BW [MHz]	Channel/Frequency(MHz)		Lowest	Middle	Highest
5 + 20	PCC	Channel	55273	55898	56523
		Frequency	3553.3	3615.8	3678.3
	SCC	Channel	55390	56015	56640
		Frequency	3565	3627.5	3690
20 + 5	PCC	Channel	55340	55965	56590
		Frequency	3560	3622.5	3685
	SCC	Channel	55457	56082	56707
		Frequency	3571.7	3634.2	3696.7
10 + 20	PCC	Channel	55295	55896	56496
		Frequency	3555.5	3615.6	3675.6
	SCC	Channel	55439	56040	56640
		Frequency	3569.9	3630	3690
20 + 10	PCC	Channel	55340	55941	56541
		Frequency	3560	3620.1	3680.1
	SCC	Channel	55484	56085	56685
		Frequency	3574.4	3634.5	3694.5



LTE Band 48C_CA Channel and Frequency List					
BW [MHz]	Channel/Frequency(MHz)		Lowest	Middle	Highest
15 + 20	PCC	Channel	55318	55893	56469
		Frequency	3557.8	3615.3	3672.9
	SCC	Channel	55489	56064	56640
		Frequency	3574.9	3632.4	3690
20 + 15	PCC	Channel	55340	55916	56491
		Frequency	3560	3617.6	3675.1
	SCC	Channel	55511	56087	56662
		Frequency	3577.1	3634.7	3692.2
20 +20	PCC	Channel	55340	55891	56442
		Frequency	3560	3615.1	3670.2
	SCC	Channel	55538	56089	56640
		Frequency	3579.8	3634.9	3690

3 Conducted Test Items

3.1 Measuring Instruments

See list of measuring instruments of this test report.

3.2 Test Setup

3.2.1 Conducted Output Power / ACLR

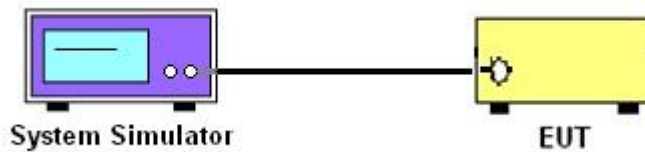

3.2.2 26dB & 99% Occupied Bandwidth, Conducted Band-Edge and Conducted Spurious Emission

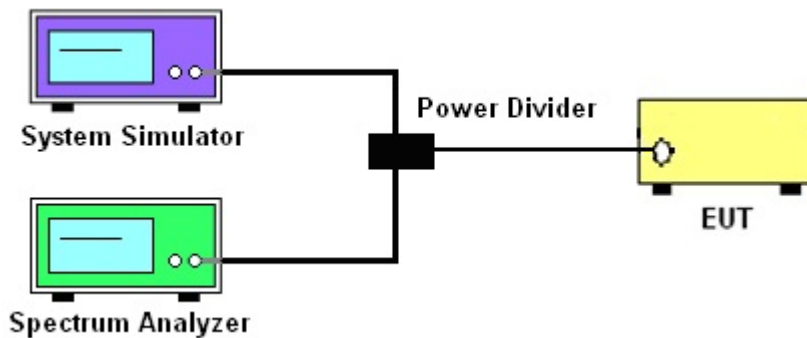

3.2.3 Frequency Stability

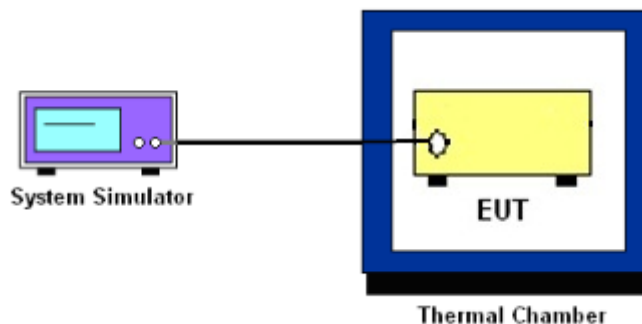

3.2.4 Test Result of Conducted Test

Please refer to Appendix A.



3.3 Conducted Output Power

3.3.1 Description of the Conducted Output Power Measurement

A system simulator was used to establish communication with the EUT. Its parameters were set to force the EUT transmitting at maximum output power. The measured power in the radio frequency on the transmitter output terminals shall be reported.

3.3.2 Test Procedures

1. The transmitter output port was connected to the system simulator.
2. Set EUT at maximum power through the system simulator.
3. Select lowest, middle, and highest channels for each band and different modulation.
4. Measure and record the power level from the system simulator.

3.3.3 Test Procedures for LTE ULCA

1. The testing follows ANSI C63.26 Section 5.2
2. The transmitter PCC & SCC output ports were connected to the system simulator.
3. Set EUT at maximum power, set the PCC/SCC CA band, channel, bandwidth and RB config.

PCC config_(Channel Bandwidth / Channel / Band) **SCC config_(Channel Bandwidth / Channel / Band)**

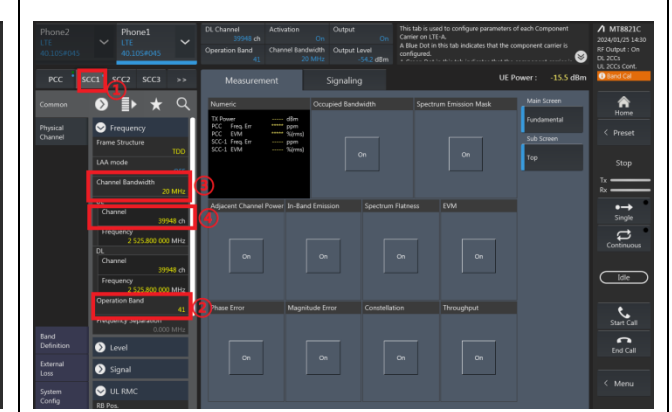
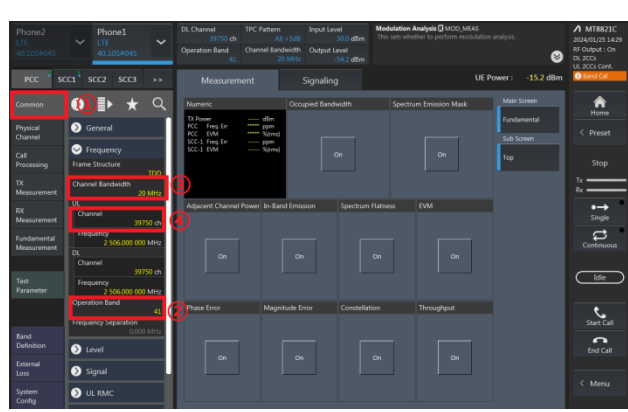

PCC config_(Number of RB / Starting RB)

SCC config_(Number of RB / Starting RB)

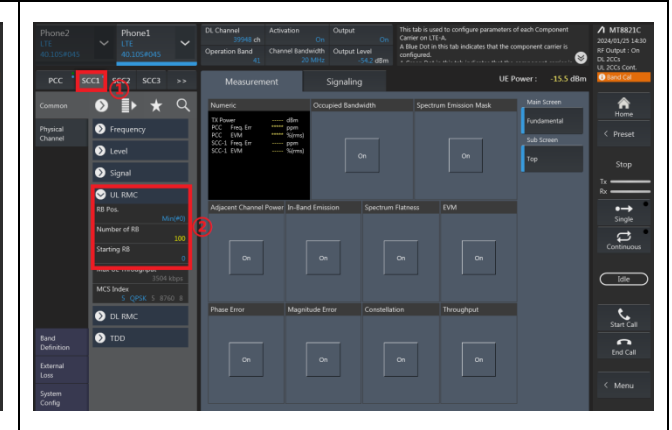
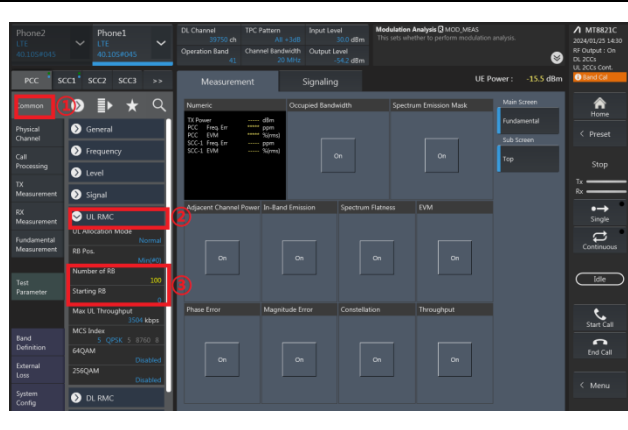

4. Select lowest, middle, and highest channels for each ULCA band and different modulation.
5. Check the ULCA spectrum and record the total power from the system simulator.

Check the ULCA spectrum (eg. 20M+20M)

Read the Total UL CA output power (PCC+SCC)

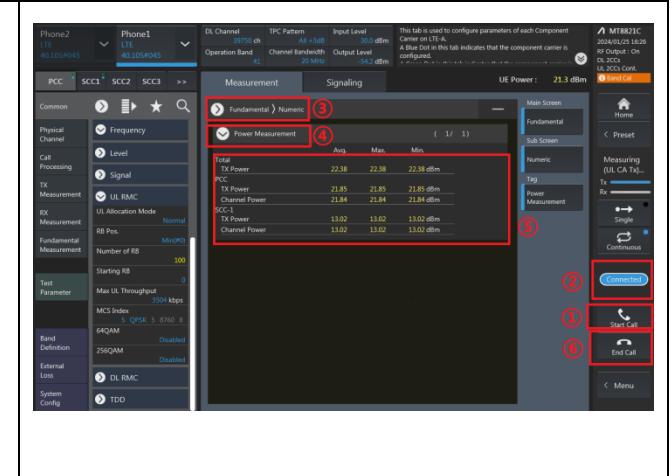
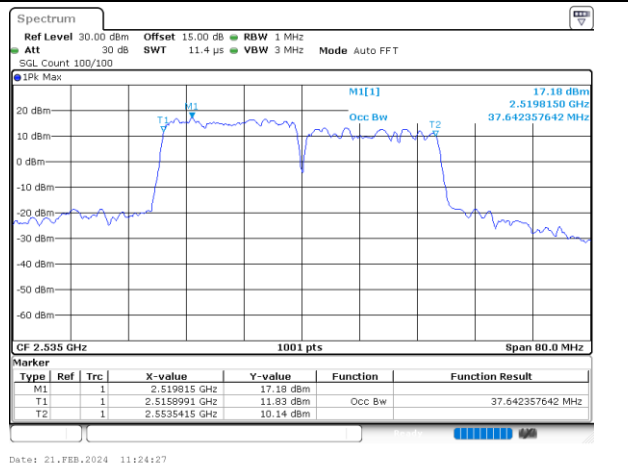

3.4 EIRP

3.4.1 Description of the EIRP Measurement

EIRP limits for CBRS equipment as below table:

Device		Maximum EIRP (dBm/10 MHz)	Maximum PSD (dBm/MHz)
Applied	End User Device	23	n/a
<input type="checkbox"/>	Category A CBSD	30	20
<input type="checkbox"/>	Category B CBSD	47	37

Remark:

1. The worst case EIRP shown in this section is found with LTE operating only using 1RB. As such, the EIRP/10MHz and full channel EIRP values will be identical since 1RB is fully contained within all available channel bandwidths for LTE Band 48 (i.e. 5, 10, 15, 20MHz)

3.4.2 Test Procedures for EIRP

1. Establishing a communications link with the call box (Base station) to measure the Maximum conducted power, the parameters were set to force the EUT transmitting at maximum output power level. Use the average power measurement function to measure total channel power of each channel bandwidth (per ANSI C63.26-2015 Section 5.2.1)
2. Determining ERP and/or EIRP from conducted RF output power measurements (Per ANSI C63.26-2015 Section 5.2.5.5)
$$\text{EIRP} = P_T + G_T - L_C, \text{ ERP} = \text{EIRP} - 2.15, \text{ where}$$

P_T = transmitter output power in dBm
 G_T = gain of the transmitting antenna in dBi
 L_C = signal attenuation in the connecting cable between the transmitter and antenna in dB



3.5 Occupied Bandwidth

3.5.1 Description of Occupied Bandwidth Measurement

The occupied bandwidth is the width of a frequency band such that, below the lower and above the upper frequency limits, the mean powers emitted are each equal to a specified percentage 0.5% of the total mean transmitted power.

The 26 dB emission bandwidth is defined as the frequency range between two points, one above and one below the carrier frequency, at which the spectral density of the emission is attenuated 26 dB below the maximum in-band spectral density of the modulated signal. Spectral density (power per unit bandwidth) is to be measured with a detector of resolution bandwidth equal to approximately 1.0% of the emission bandwidth.

3.5.2 Test Procedures

The testing follows ANSI C63.26-2015 Section 5.4.3 (26dB) and Section 5.4.4 (99OB)

1. The EUT was connected to spectrum analyzer and system simulator via a power divider.
2. The spectrum analyzer center frequency is set to the nominal EUT channel center frequency. The span range for the spectrum analyzer shall be between two and five times the anticipated OBW.
3. The nominal resolution bandwidth (RBW) shall be in the range of 1 to 5 % of the anticipated OBW, and the VBW shall be at least 3 times the RBW.
4. Set the detection mode to peak, and the trace mode to max hold.
5. Determine the reference value: Set the EUT to transmit a modulated signal. Allow the trace to stabilize. Set the spectrum analyzer marker to the highest level of the displayed trace.
(this is the reference value)
6. Determine the “-26 dB down amplitude” as equal to (Reference Value – X).
7. Place two markers, one at the lowest and the other at the highest frequency of the envelope of the spectral display such that each marker is at or slightly below the “-X dB down amplitude” determined in step 6. If a marker is below this “-X dB down amplitude” value it shall be placed as close as possible to this value. The OBW is the positive frequency difference between the two markers.
8. Use the 99 % power bandwidth function of the spectrum analyzer and report the measured bandwidth.



3.6 Conducted Band Edge

3.6.1 Description of Conducted Band Edge Measurement

Part 96.41 (e) (1) (ii)

For End User Devices the emission limits outside the fundamental are as follows:

Within 0 MHz to B MHz above and below the assigned channel ≤ -13 dBm/MHz

Greater than B MHz above and below the assigned channel ≤ -25 dBm/MHz

where B is the bandwidth in megahertz of the assigned channel or multiple contiguous channels of the End User Device.

Notwithstanding the emission limits in this paragraph, the Adjacent Channel Leakage Ratio for End User Devices shall be at least 30 dB.

Part 96.41 (e) (2)

For CBSDs and End User Devices, the conducted power of emissions below 3540 MHz or above 3710 MHz shall not exceed -25 dBm/MHz, and the conducted power of emissions below 3530 MHz or above 3720 MHz shall not exceed -40 dBm/MHz

3.6.2 Test Procedures

The testing follows FCC KDB 971168 D01 v03r01 Section 6.1.

1. The EUT was connected to spectrum analyzer and system simulator via a power divider.
2. The band edges of low and high channels for the highest RF powers were measured.
3. Set RBW $\geq 1\%$ EBW in the 1MHz band immediately outside and adjacent to the band edge.
4. Beyond the 1 MHz band from the band edge, RBW=1MHz was used
5. Offset has included the duty factor for LTE Band 48. Duty factor $=10 \log (1/x)$, where x is the measured duty cycle.
6. Set spectrum analyzer with RMS detector.
7. The RF fundamental frequency should be excluded against the limit line in the operating frequency band.



3.7 Conducted Spurious Emission

3.7.1 Description of Conducted Spurious Emission Measurement

96.41 (e)(2)

The conducted power of any emissions below 3530 MHz or above 3720 MHz shall not exceed -40dBm/MHz.

3.7.2 Test Procedures

The testing follows FCC KDB 971168 D01 v03r01 Section 6.1.

1. The EUT was connected to spectrum analyzer and system simulator via a power divider.
2. The RF output of EUT was connected to the spectrum analyzer by RF cable and attenuator. The path loss was compensated to the results for each measurement.
3. The middle channel for the highest RF power within the transmitting frequency was measured.
4. The conducted spurious emission for the whole frequency range was taken.
5. Make the measurement with the spectrum analyzer's RBW = 1MHz, VBW = 3MHz.
6. Set spectrum analyzer with RMS detector.
7. Taking the record of maximum spurious emission.
8. The RF fundamental frequency should be excluded against the limit line in the operating frequency band.
9. The limit line is -40dBm/MHz.



3.8 Frequency Stability

3.8.1 Description of Frequency Stability Measurement

The frequency stability shall be measured by variation of ambient temperature and variation of primary supply voltage to ensure that the fundamental emission stays within the authorized frequency block.

3.8.2 Test Procedures for Temperature Variation

The testing follows FCC KDB 971168 D01 v03r01 Section 9.0.

1. The EUT was set up in the thermal chamber and connected with the system simulator.
2. With power OFF, the temperature was decreased to -30°C and the EUT was stabilized before testing. Power was applied and the maximum change in frequency was recorded within one minute.
3. With power OFF, the temperature was raised in 10°C step up to 50°C. The EUT was stabilized at each step for at least half an hour. Power was applied and the maximum frequency change was recorded within one minute.

3.8.3 Test Procedures for Voltage Variation

The testing follows FCC KDB 971168 D01 v03r01 Section 9.0.

1. The EUT was placed in a temperature chamber at 25±5° C and connected with the system simulator.
2. The power supply voltage to the EUT was varied from 85% to 115% of the nominal value measured at the input to the EUT.
3. The variation in frequency was measured for the worst case.

4 Radiated Test Items

4.1 Measuring Instruments

See list of measuring instruments of this test report.

4.2 Test Setup

4.2.1 For radiated test below 30MHz

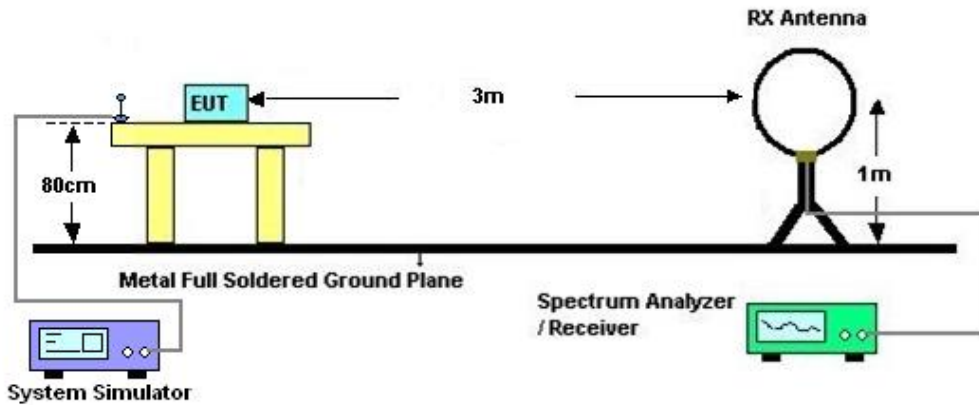

4.2.2 For radiated test from 30MHz to 1GHz

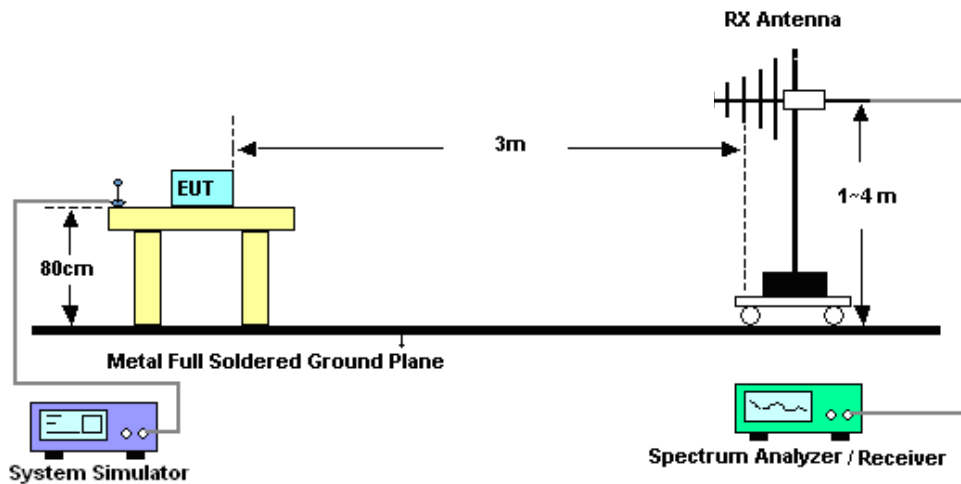

4.2.3 For radiated test above 1GHz

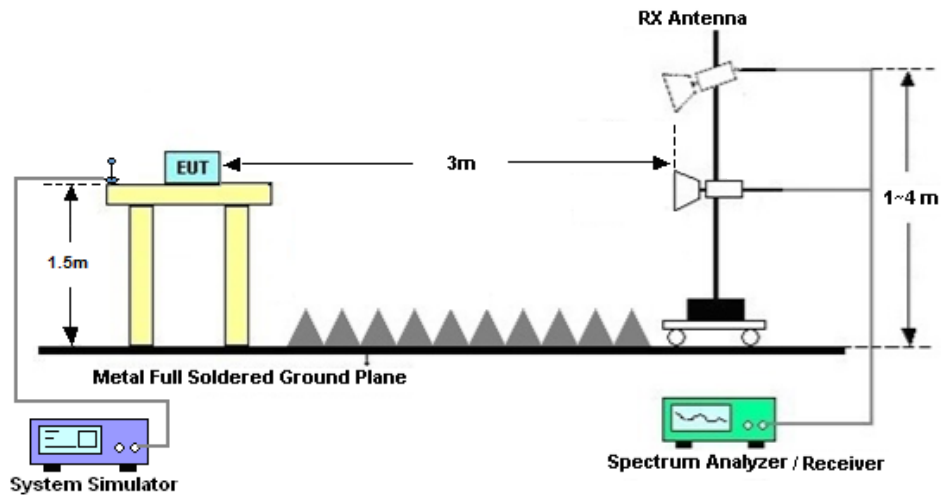

4.3 Test Result of Radiated Test

The low frequency, which started from 9 kHz to 30MHz, was pre-scanned and the result which was 20dB lower than the limit line was not reported.

Please refer to Appendix B.



4.4 Radiated Spurious Emission

4.4.1 Description of Radiated Spurious Emission Measurement

The radiated spurious emission was measured by substitution method according to ANSI C63.26-2015. The power of any emission outside of the authorized operating frequency ranges must be attenuated below the transmitter power (P) by a factor of at least -40dBm / MHz. The spectrum is scanned from 30 MHz up to a frequency including its 10th harmonic.

4.4.2 Test Procedures

1. The EUT was placed on a turntable with 0.8 meter height for frequency below 1GHz and 1.5 meter height for frequency above 1GHz respectively above ground.
2. The EUT was set 3 meters from the receiving antenna mounted on the antenna tower.
3. The table was rotated 360 degrees to determine the position of the highest spurious emission.
4. The height of the receiving antenna is varied between 1m to 4m to search the maximum spurious emission for both horizontal and vertical polarizations.
5. During the measurement, the system simulator parameters were set to force the EUT transmitting at maximum output power.
6. Make the measurement with the spectrum analyzer's RBW = 1MHz, VBW = 3MHz, taking the record of maximum spurious emission.
7. A horn antenna was substituted in place of the EUT and was driven by a signal generator. Tune the output power of signal generator to the same emission level with EUT maximum spurious emission.
$$\text{EIRP (dBm)} = \text{S.G. Power} - \text{Tx Cable Loss} + \text{Tx Antenna Gain}$$
$$\text{ERP (dBm)} = \text{EIRP} - 2.15$$
8. The RF fundamental frequency should be excluded against the limit line in the operating frequency band.
The limit line is -40dBm/MHz



5 List of Measuring Equipment

Instrument	Manufacturer	Model No.	Serial No.	Characteristics	Calibration Date	Test Date	Due Date	Remark
Spectrum Analyzer	R&S	FSV40	101078	10Hz~40GHz	Apr. 09, 2024	Nov. 12, 2024~ Nov. 28, 2024	Apr. 08, 2025	Conducted (TH01-SZ)
DC Power Supply	TTI	PL330P	290070	Max 32V , 3A	Oct. 16, 2024	Nov. 12, 2024~ Nov. 28, 2024	Oct. 15, 2025	Conducted (TH01-SZ)
Power Divider	TOJOIN	PS-2SM-04 265	60.06.020.007 7	0.4GHz~26.5GHz	Dec. 25, 2023	Nov. 12, 2024~ Nov. 28, 2024	Dec. 24, 2024	Conducted (TH01-SZ)
Thermal Chamber	Ten Billion Hongzhangroup	LP-150U	H2014081803	-40~+150°C	Jul. 03, 2024	Nov. 12, 2024~ Nov. 28, 2024	Jul. 02, 2025	Conducted (TH01-SZ)
EXA Spectrum Analyzer	Keysight	N9010A	MY55370528	10Hz-44G,MAX 30dB	Oct. 11, 2024	Dec. 07, 2024	Oct. 10, 2025	Radiation (03CH04-KS)
Loop Antenna	R&S	HFH2-Z2E	101125	9kHz~30MHz	Sep. 08, 2024	Dec. 07, 2024	Sep. 07, 2025	Radiation (03CH04-KS)
Bilog Antenna	TeseQ	CBL6111D	44483	30MHz-1GHz	Dec. 06, 2024	Dec. 07, 2024	Dec. 05, 2025	Radiation (03CH04-KS)
Double Ridge Horn Antenna	ETS-Lindgren	3117	00227860	1GHz~18GHz	Aug. 16, 2024	Dec. 07, 2024	Aug. 15, 2025	Radiation (03CH04-KS)
SHF-EHF Horn	Com-power	AH-840	101070	18GHz~40GHz	Jan. 27, 2024	Dec. 07, 2024	Jan. 26, 2025	Radiation (03CH04-KS)
Amplifier	SONOMA	310N	413740	9KHz-1GHz	Jan. 03, 2024	Dec. 07, 2024	Jan. 02, 2025	Radiation (03CH04-KS)
Amplifier	EM	EM18G40G A	060728	18~40GHz	Jan. 02, 2024	Dec. 07, 2024	Jan. 01, 2025	Radiation (03CH04-KS)
high gain Amplifier	EM	EM01G18G A	060840	1Ghz-18Ghz	Oct. 09, 2024	Dec. 07, 2024	Oct. 08, 2025	Radiation (03CH04-KS)
Amplifier	EM	EM01G18G A	060892	1Ghz-18Ghz	Oct. 09, 2024	Dec. 07, 2024	Oct. 08, 2025	Radiation (03CH04-KS)
AC Power Source	Chroma	61601	F104090004	N/A	NCR	Dec. 07, 2024	NCR	Radiation (03CH04-KS)
Turn Table	ChamPro	EM 1000-T	060762-T	0~360 degree	NCR	Dec. 07, 2024	NCR	Radiation (03CH04-KS)
Antenna Mast	ChamPro	EM 1000-A	060762-A	1 m~4 m	NCR	Dec. 07, 2024	NCR	Radiation (03CH04-KS)
EXA Spectrum Analyzer	Keysight	N9010A	MY55370528	10Hz-44G,MAX 30dB	Oct. 11, 2024	Dec. 07, 2024	Oct. 10, 2025	Radiation (03CH04-KS)

NCR: No Calibration Required



6 Measurement Uncertainty

Uncertainty of Conducted Measurement

Test Item	Uncertainty
Conducted Spurious Emission & Bandedge	±1.34 dB
Occupied Channel Bandwidth	±0.012 MHz
Conducted Power	±1.34 dB
Peak to Average Ratio	±1.34 dB
Frequency Stability	±1.3 Hz

Uncertainty of Radiated Emission Measurement (30 MHz ~ 1000 MHz)

Measuring Uncertainty for a Level of Confidence of 95% (U = 2Uc(y))	2.83dB
---	--------

Uncertainty of Radiated Emission Measurement (1 GHz ~ 18 GHz)

Measuring Uncertainty for a Level of Confidence of 95% (U = 2Uc(y))	2.83dB
---	--------

Uncertainty of Radiated Emission Measurement (18 GHz ~ 40 GHz)

Measuring Uncertainty for a Level of Confidence of 95% (U = 2Uc(y))	2.82dB
---	--------

----- THE END -----



Appendix A. Test Results of Conducted Test

Test Engineer :	Khan Zhen	Temperature :	22~23°C
		Relative Humidity :	40~42%

Conducted Output Power(Average power) and EIRP

LTE Band 48_ANT9:

BW [MHz]	Modulation	RB Size	RB Offset	Power Low Ch. / Freq.	Power Middle Ch. / Freq.	Power High Ch. / Freq.	EIRP(W)		
							L	M	H
Channel				55340	55990	56640			
Frequency (MHz)				3560	3625	3690	L	M	H
20	QPSK	1	0	23.10	23.37	23.02	0.1820	0.1936	0.1786
20	QPSK	1	49	23.00	23.27	22.88	0.1778	0.1892	0.1730
20	QPSK	1	99	22.96	23.25	22.90	0.1762	0.1884	0.1738
20	QPSK	50	0	22.99	23.34	22.96	0.1774	0.1923	0.1762
20	QPSK	50	24	23.05	23.33	22.85	0.1799	0.1919	0.1718
20	QPSK	50	50	23.06	23.30	22.92	0.1803	0.1905	0.1746
20	QPSK	100	0	23.07	23.29	22.95	0.1807	0.1901	0.1758
20	16QAM	1	0	23.06	23.35	22.89	0.1803	0.1928	0.1734
20	16QAM	1	49	22.95	23.22	22.92	0.1758	0.1871	0.1746
20	16QAM	1	99	22.95	23.20	22.99	0.1758	0.1862	0.1774
20	16QAM	50	0	22.02	22.36	21.98	0.1419	0.1535	0.1406
20	16QAM	50	24	22.16	22.26	22.08	0.1466	0.1500	0.1439
20	16QAM	50	50	22.13	22.30	22.03	0.1455	0.1514	0.1422
20	16QAM	100	0	22.20	22.27	21.95	0.1479	0.1503	0.1396
20	64QAM	1	0	22.02	22.30	22.11	0.1419	0.1514	0.1449
20	64QAM	1	49	22.18	22.38	21.91	0.1472	0.1542	0.1384
20	64QAM	1	99	22.01	22.33	22.00	0.1416	0.1524	0.1413
20	64QAM	50	0	21.05	21.39	20.93	0.1135	0.1227	0.1104
20	64QAM	50	24	21.04	21.29	21.10	0.1132	0.1199	0.1148
20	64QAM	50	50	21.00	21.25	20.98	0.1122	0.1189	0.1117
20	64QAM	100	0	21.11	21.41	20.92	0.1151	0.1233	0.1102
20	256QAM	1	0	19.02	19.30	18.96	0.0711	0.0759	0.0701
20	256QAM	1	49	19.00	19.46	18.98	0.0708	0.0787	0.0705
20	256QAM	1	99	18.99	19.41	19.14	0.0706	0.0778	0.0731
20	256QAM	50	0	19.17	19.38	19.06	0.0736	0.0773	0.0718
20	256QAM	50	24	19.16	19.45	18.97	0.0735	0.0785	0.0703
20	256QAM	50	50	19.02	19.47	18.98	0.0711	0.0789	0.0705
20	256QAM	100	0	19.18	19.34	19.14	0.0738	0.0766	0.0731
Channel				55315	55990	56665	EIRP(W)		
Frequency (MHz)				3557.5	3625	3692.5	L	M	H
15	QPSK	1	0	22.94	23.22	22.97	0.1754	0.1871	0.1766
15	QPSK	1	37	22.93	23.16	22.72	0.1750	0.1845	0.1667
15	QPSK	1	74	22.87	23.08	22.75	0.1726	0.1811	0.1679



15	QPSK	36	0	22.94	23.31	22.82	0.1754	0.1910	0.1706
15	QPSK	36	20	22.90	23.17	22.82	0.1738	0.1849	0.1706
15	QPSK	36	39	22.97	23.26	22.88	0.1766	0.1888	0.1730
15	QPSK	75	0	22.94	23.16	22.78	0.1754	0.1845	0.1690
15	16QAM	1	0	23.02	23.24	22.91	0.1786	0.1879	0.1742
15	16QAM	1	37	22.93	23.18	22.85	0.1750	0.1854	0.1718
15	16QAM	1	74	22.84	23.09	22.94	0.1714	0.1816	0.1754
15	16QAM	36	0	22.20	22.44	21.98	0.1479	0.1563	0.1406
15	16QAM	36	20	22.18	22.28	22.04	0.1472	0.1507	0.1426
15	16QAM	36	39	22.13	22.31	22.05	0.1455	0.1517	0.1429
15	16QAM	75	0	22.13	22.13	21.87	0.1455	0.1455	0.1371
15	64QAM	1	0	21.99	22.17	21.97	0.1409	0.1469	0.1403
15	64QAM	1	37	22.00	22.22	21.80	0.1413	0.1486	0.1349
15	64QAM	1	74	21.90	22.24	21.95	0.1380	0.1493	0.1396
15	64QAM	36	0	20.96	21.36	20.89	0.1112	0.1219	0.1094
15	64QAM	36	20	20.97	21.20	21.06	0.1114	0.1175	0.1138
15	64QAM	36	39	20.87	21.09	20.95	0.1089	0.1146	0.1109
15	64QAM	75	0	20.97	21.35	20.88	0.1114	0.1216	0.1091
15	256QAM	1	0	19.07	19.30	19.10	0.0719	0.0759	0.0724
15	256QAM	1	37	19.05	19.41	18.96	0.0716	0.0778	0.0701
15	256QAM	1	74	19.05	19.44	18.96	0.0716	0.0783	0.0701
15	256QAM	36	0	19.08	19.25	18.95	0.0721	0.0750	0.0700
15	256QAM	36	20	19.05	19.37	18.93	0.0716	0.0771	0.0697
15	256QAM	36	39	18.95	19.31	18.91	0.0700	0.0760	0.0693
15	256QAM	75	0	19.13	19.29	19.00	0.0729	0.0757	0.0708
Channel				55290	55990	56690	EIRP(W)		
Frequency (MHz)				3555	3625	3695	L	M	H
10	QPSK	1	0	22.93	23.30	22.95	0.1750	0.1905	0.1758
10	QPSK	1	25	23.03	23.33	22.95	0.1791	0.1919	0.1758
10	QPSK	1	49	22.86	23.20	22.83	0.1722	0.1862	0.1710
10	QPSK	25	0	22.93	23.18	22.89	0.1750	0.1854	0.1734
10	QPSK	25	12	23.00	23.17	22.80	0.1778	0.1849	0.1698
10	QPSK	25	25	22.97	23.14	22.78	0.1766	0.1837	0.1690
10	QPSK	50	0	22.96	23.12	22.85	0.1762	0.1828	0.1718
10	16QAM	1	0	22.93	23.21	22.72	0.1750	0.1866	0.1667
10	16QAM	1	25	22.78	23.19	22.80	0.1690	0.1858	0.1698
10	16QAM	1	49	22.84	23.03	22.92	0.1714	0.1791	0.1746
10	16QAM	25	0	21.93	22.31	21.87	0.1390	0.1517	0.1371
10	16QAM	25	12	22.10	22.15	21.98	0.1445	0.1462	0.1406
10	16QAM	25	25	22.02	22.15	21.97	0.1419	0.1462	0.1403
10	16QAM	50	0	22.02	22.20	21.80	0.1419	0.1479	0.1349
10	64QAM	1	0	21.99	22.20	21.93	0.1409	0.1479	0.1390
10	64QAM	1	25	22.13	22.32	21.85	0.1455	0.1521	0.1365
10	64QAM	1	49	21.94	22.31	21.89	0.1393	0.1517	0.1377
10	64QAM	25	0	21.02	21.22	20.82	0.1127	0.1180	0.1076
10	64QAM	25	12	20.96	21.13	20.97	0.1112	0.1156	0.1114
10	64QAM	25	25	20.92	21.08	20.83	0.1102	0.1143	0.1079
10	64QAM	50	0	20.96	21.33	20.85	0.1112	0.1211	0.1084



10	256QAM	1	0	19.14	19.28	18.90	0.0731	0.0755	0.0692
10	256QAM	1	25	19.05	19.33	19.05	0.0716	0.0764	0.0716
10	256QAM	1	49	18.89	19.30	19.04	0.0690	0.0759	0.0714
10	256QAM	25	0	19.02	19.26	18.92	0.0711	0.0752	0.0695
10	256QAM	25	12	19.16	19.31	18.90	0.0735	0.0760	0.0692
10	256QAM	25	25	19.15	19.35	19.14	0.0733	0.0767	0.0731
10	256QAM	50	0	19.03	19.32	18.99	0.0713	0.0762	0.0706
Channel				55265	55990	56715	EIRP(W)		
Frequency (MHz)				3552.5	3625	3697.5	L	M	H
5	QPSK	1	0	23.01	23.22	22.84	0.1782	0.1871	0.1714
5	QPSK	1	12	22.86	23.16	22.76	0.1722	0.1845	0.1683
5	QPSK	1	24	22.89	23.09	22.75	0.1734	0.1816	0.1679
5	QPSK	12	0	22.95	23.28	22.89	0.1758	0.1897	0.1734
5	QPSK	12	7	22.99	23.27	22.94	0.1774	0.1892	0.1754
5	QPSK	12	13	22.95	23.15	22.80	0.1758	0.1841	0.1698
5	QPSK	25	0	22.99	23.16	22.80	0.1774	0.1845	0.1698
5	16QAM	1	0	23.04	23.23	22.83	0.1795	0.1875	0.1710
5	16QAM	1	12	22.84	23.19	22.88	0.1714	0.1858	0.1730
5	16QAM	1	24	22.81	23.17	22.86	0.1702	0.1849	0.1722
5	16QAM	12	0	21.88	22.26	21.86	0.1374	0.1500	0.1368
5	16QAM	12	7	22.01	22.20	21.96	0.1416	0.1479	0.1400
5	16QAM	12	13	22.08	22.15	22.01	0.1439	0.1462	0.1416
5	16QAM	25	0	22.18	22.24	21.88	0.1472	0.1493	0.1374
5	64QAM	1	0	21.97	22.12	22.09	0.1403	0.1452	0.1442
5	64QAM	1	12	22.02	22.25	21.83	0.1419	0.1496	0.1358
5	64QAM	1	24	21.91	22.26	21.88	0.1384	0.1500	0.1374
5	64QAM	12	0	21.09	21.31	21.05	0.1146	0.1205	0.1135
5	64QAM	12	7	21.19	21.39	21.07	0.1172	0.1227	0.1140
5	64QAM	12	13	21.04	21.40	21.09	0.1132	0.1230	0.1146
5	64QAM	25	0	21.06	21.30	20.88	0.1138	0.1202	0.1091
5	256QAM	1	0	18.90	19.15	18.92	0.0692	0.0733	0.0695
5	256QAM	1	12	18.97	19.30	18.85	0.0703	0.0759	0.0684
5	256QAM	1	24	18.83	19.25	19.10	0.0681	0.0750	0.0724
5	256QAM	12	0	19.14	19.45	18.96	0.0731	0.0785	0.0701
5	256QAM	12	7	19.19	19.44	19.13	0.0740	0.0783	0.0729
5	256QAM	12	13	19.15	19.32	18.95	0.0733	0.0762	0.0700
5	256QAM	25	0	19.07	19.20	19.08	0.0719	0.0741	0.0721



LTE CA_48B_ANT9:

Combination 10MHz+10MHz (100RB+100RB)							
Channel	Modulation	PCC		SCC		Measured Power	EIRP(W)
		RB Size	RB offset	RB Size	RB offset		
L	QPSK	1	Max	1	0	23.49	0.1991
M	QPSK	1	Max	1	0	23.36	0.1932
H	QPSK	1	Max	1	0	23.22	0.1871
L	16QAM	1	Max	1	0	23.48	0.1986
M	16QAM	1	Max	1	0	23.28	0.1897
H	16QAM	1	Max	1	0	23.17	0.1849
L	64QAM	1	Max	1	0	23.22	0.1871
M	64QAM	1	Max	1	0	23.15	0.1841
H	64QAM	1	Max	1	0	23.04	0.1795
L	256QAM	1	Max	1	0	20.30	0.0955
M	256QAM	1	Max	1	0	20.15	0.0923
H	256QAM	1	Max	1	0	19.91	0.0873

LTE CA_48C_ANT9:

Combination 20MHz+20MHz (100RB+100RB)							
Channel	Modulation	PCC		SCC		Measured Power	EIRP(W)
		RB Size	RB offset	RB Size	RB offset		
L	QPSK	1	Max	1	0	18.12	0.0578
M	QPSK	1	Max	1	0	21.45	0.1245
H	QPSK	1	Max	1	0	18.03	0.0566
L	16QAM	1	Max	1	0	18.07	0.0571
M	16QAM	1	Max	1	0	21.28	0.1197
H	16QAM	1	Max	1	0	17.93	0.0553
L	64QAM	1	Max	1	0	18.10	0.0575
M	64QAM	1	Max	1	0	20.41	0.0979
H	64QAM	1	Max	1	0	17.89	0.0548
L	256QAM	1	Max	1	0	17.61	0.0514
M	256QAM	1	Max	1	0	17.37	0.0486
H	256QAM	1	Max	1	0	17.38	0.0488
Combination 20MHz+15MHz (100RB+75RB)							
Channel	Modulation	PCC		SCC		Measured Power	EIRP(W)
		RB Size	RB offset	RB Size	RB offset		
M	QPSK	1	Max	1	0	21.38	0.1225
M	16QAM	1	Max	1	0	21.31	0.1205
Combination 15MHz+20MHz (100RB+75RB)							
Channel	Modulation	PCC		SCC		Measured Power	EIRP(W)
		RB Size	RB offset	RB Size	RB offset		
M	QPSK	1	Max	1	0	21.35	0.1216
M	16QAM	1	Max	1	0	21.26	0.1191



Combination 20MHz+10MHz (100RB+50RB)							
Channel	Modulation	PCC		SCC		Measured Power	EIRP(W)
		RB Size	RB offset	RB Size	RB offset		
M	QPSK	1	Max	1	0	21.08	0.1143
M	16QAM	1	Max	1	0	20.97	0.1114
Combination 10MHz+20MHz (50RB+100RB)							
Channel	Modulation	PCC		SCC		Measured Power	EIRP(W)
		RB Size	RB offset	RB Size	RB offset		
M	QPSK	1	Max	1	0	21.21	0.1178
M	16QAM	1	Max	1	0	21.13	0.1156
Combination 20MHz+5MHz (100RB+25RB)							
Channel	Modulation	PCC		SCC		Measured Power	EIRP(W)
		RB Size	RB offset	RB Size	RB offset		
M	QPSK	1	Max	1	0	20.60	0.1023
M	16QAM	1	Max	1	0	20.48	0.0995
Combination 5MHz+20MHz (25RB+100RB)							
Channel	Modulation	PCC		SCC		Measured Power	EIRP(W)
		RB Size	RB offset	RB Size	RB offset		
M	QPSK	1	Max	1	0	20.61	0.1026
M	16QAM	1	Max	1	0	20.53	0.1007



LTE Band 48(Main PA)

Peak-to-Average Ratio

Mode	LTE Band 48 / 20MHz			
Mod.	QPSK	16QAM	64QAM	Limit: 13dB
RB Size	Full RB	Full RB	Full RB	Result
Middle CH	5.04	5.97	6.35	PASS

LTE Band 48 / 20MHz / QPSK	LTE Band 48 / 20MHz / 16QAM
Middle Channel / Full RB	Middle Channel / Full RB

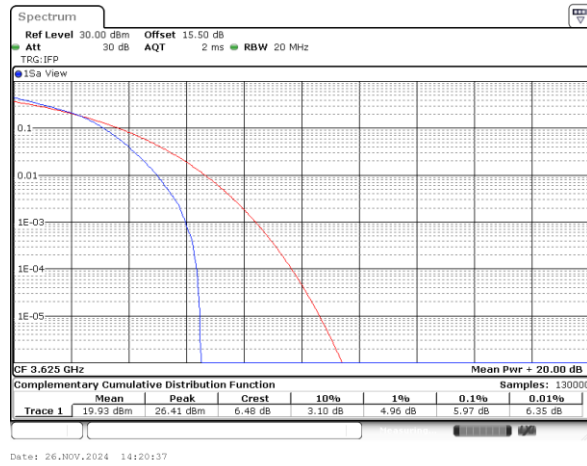
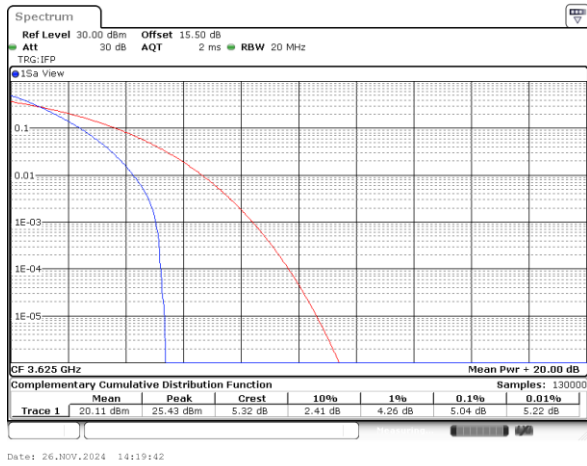

LTE Band 48 / 20MHz / 64QAM

Middle Channel / Full RB

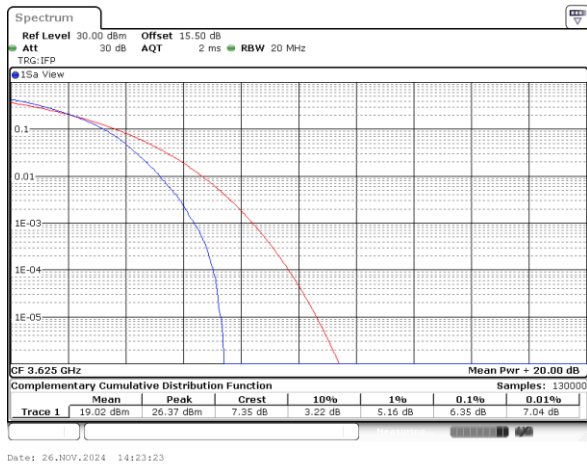



26dB Bandwidth

Mode	LTE Band 48 : 26dB BW(MHz)											
	BW	1.4MHz		3MHz		5MHz		10MHz		15MHz		20MHz
Mod.	QPSK	16QAM	QPSK	16QAM	QPSK	16QAM	QPSK	16QAM	QPSK	16QAM	QPSK	16QAM
Middle CH	-	-	-	-	5.15	4.99	9.97	9.63	14.51	14.27	18.62	19.02

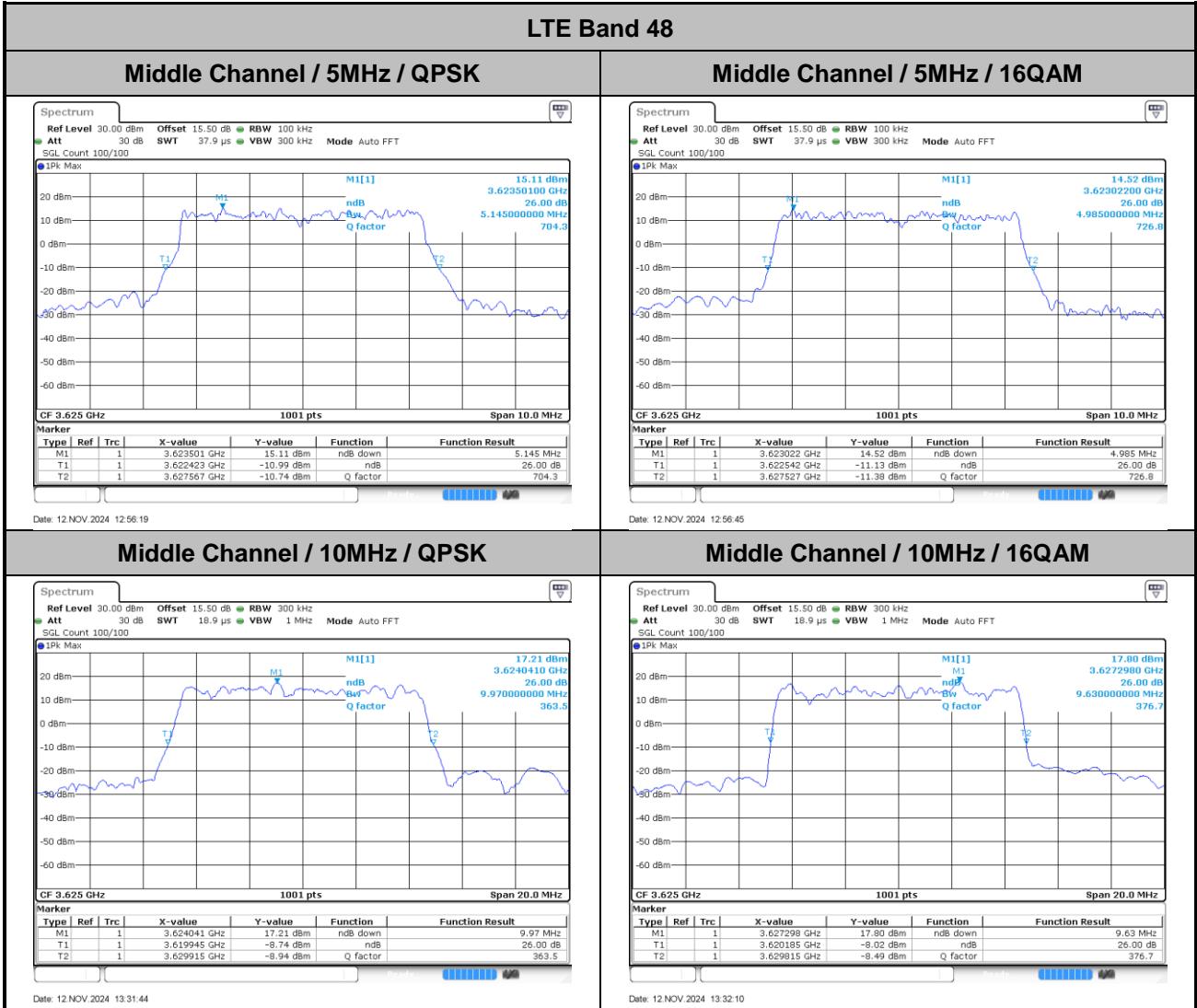



Middle Channel / 15MHz / QPSK

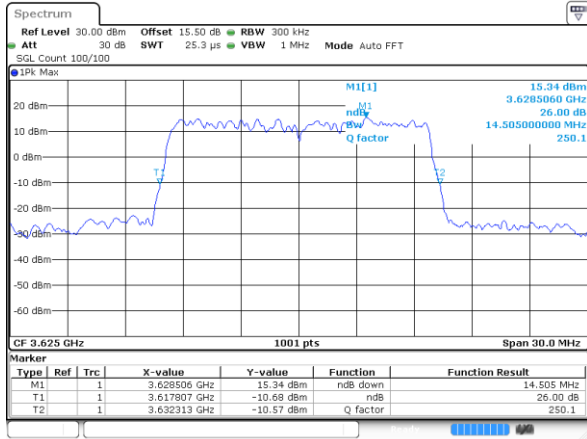

Date: 12 NOV 2024 13:56:59

Middle Channel / 15MHz / 16QAM

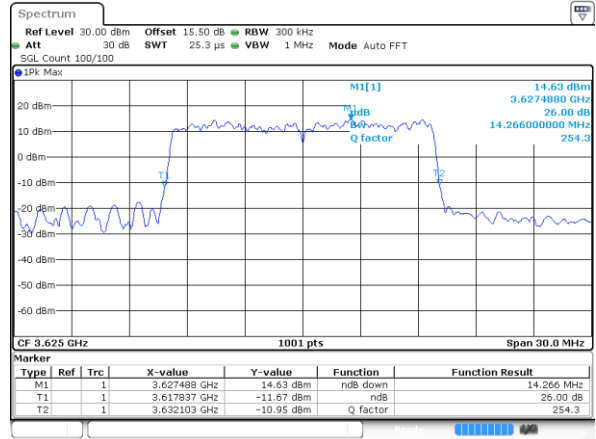

Date: 12 NOV 2024 13:57:24

LTE Band 48

Middle Channel / 20MHz / QPSK

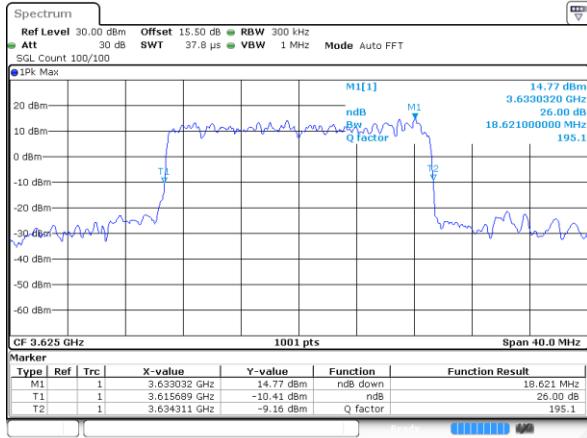

Date: 12 NOV 2024 14:23:46

Middle Channel / 20MHz / 16QAM

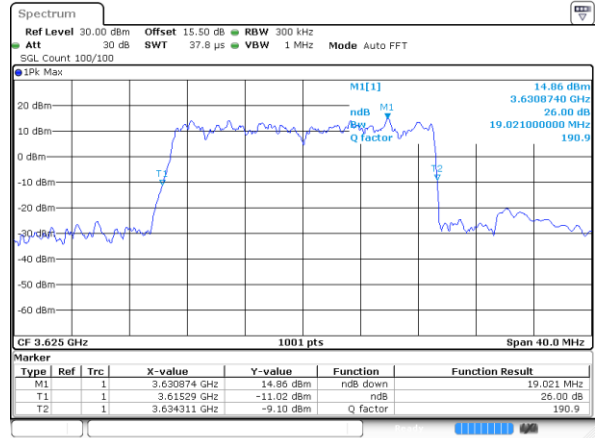

Date: 12 NOV 2024 14:23:21



Occupied Bandwidth

Mode	LTE Band 48 : 99%OBW(MHz)											
	1.4MHz		3MHz		5MHz		10MHz		15MHz		20MHz	
BW	1.4MHz	1.4MHz	3MHz	3MHz	5MHz	5MHz	10MHz	10MHz	15MHz	15MHz	20MHz	20MHz
Mod.	QPSK	16QAM	QPSK	16QAM	QPSK	16QAM	QPSK	16QAM	QPSK	16QAM	QPSK	16QAM
Middle CH	-	-	-	-	4.51	4.48	9.01	9.01	13.46	13.43	17.86	17.86

LTE Band 48

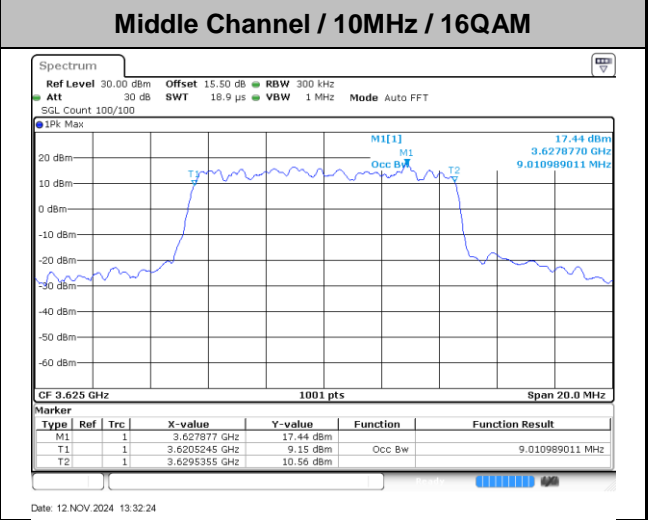
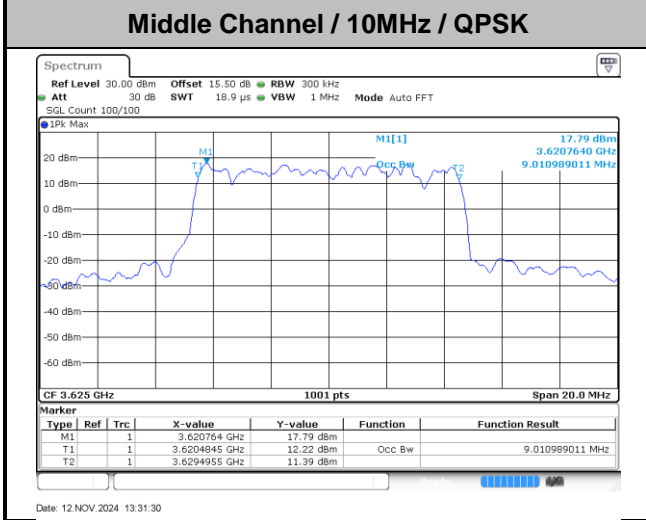
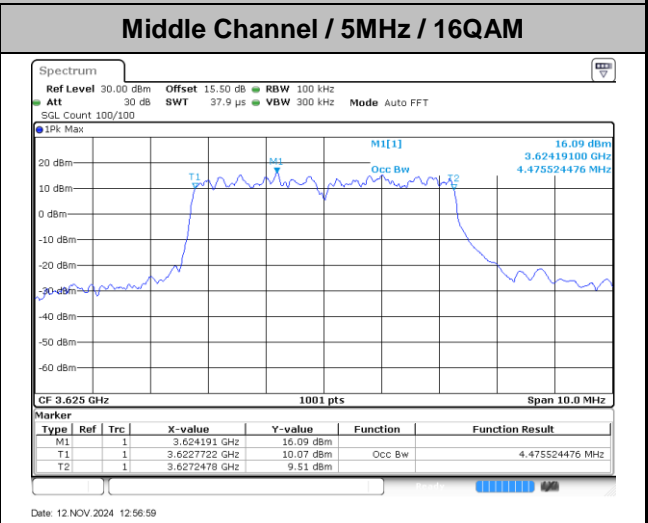
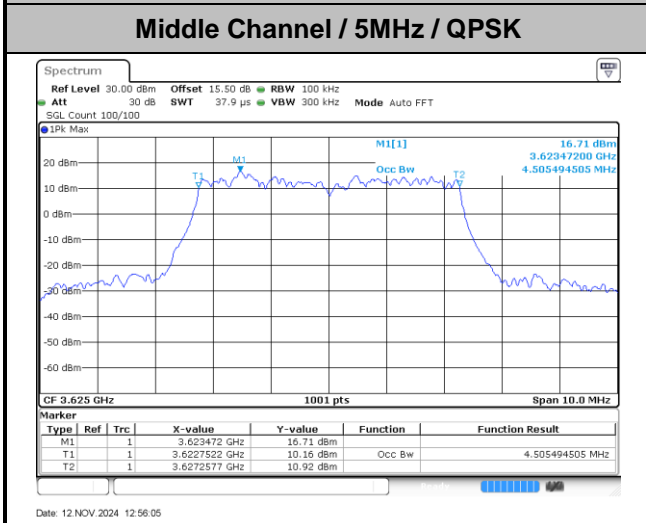



Middle Channel / 15MHz / QPSK

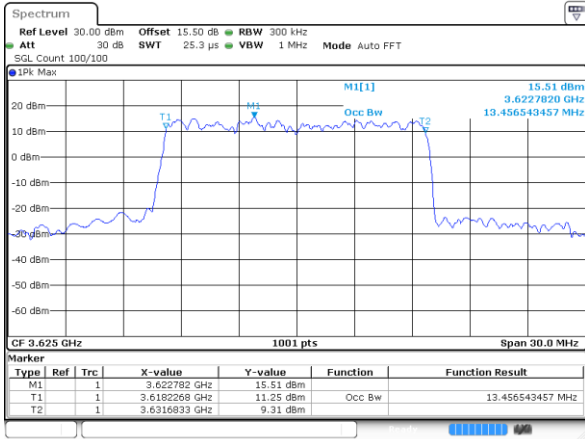

Date: 12 NOV 2024 13:56:45

Middle Channel / 15MHz / 16QAM

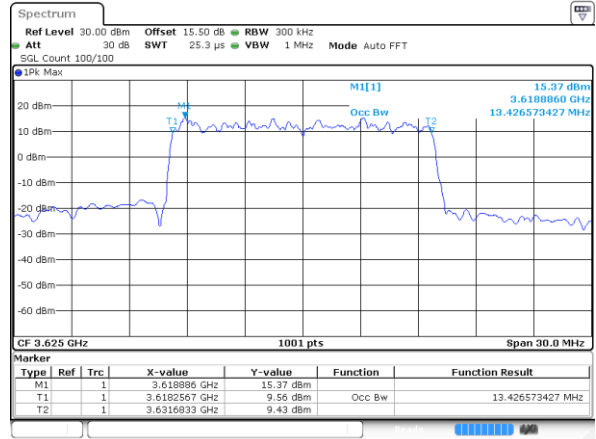

Date: 12 NOV 2024 13:57:38

LTE Band 48

Middle Channel / 20MHz / QPSK

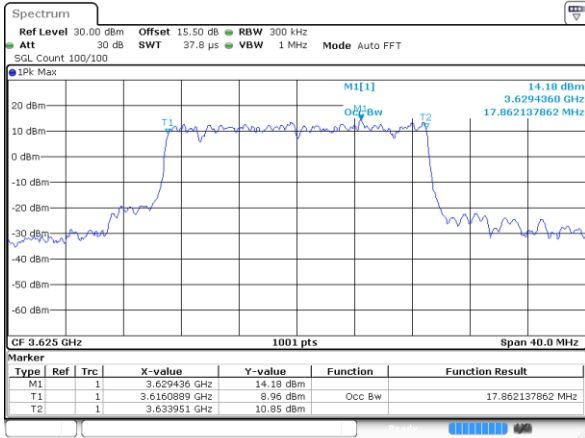

Date: 12 NOV 2024 14:24:00

Middle Channel / 20MHz / 16QAM

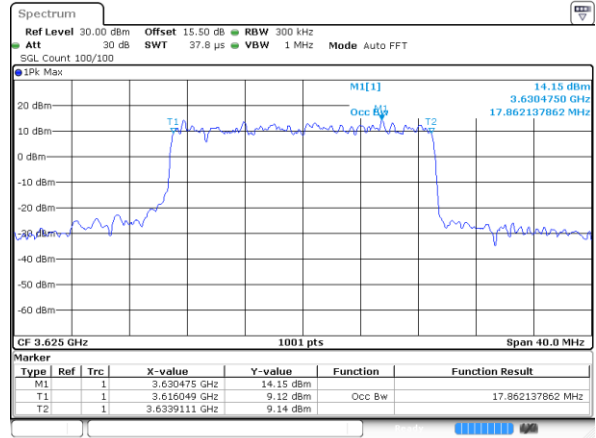

Date: 12 NOV 2024 14:23:07



ACLR

LTE Band 48 / 5MHz

QPSK

Lowest Channel / 1RB0

Lowest Channel / 1RBmax

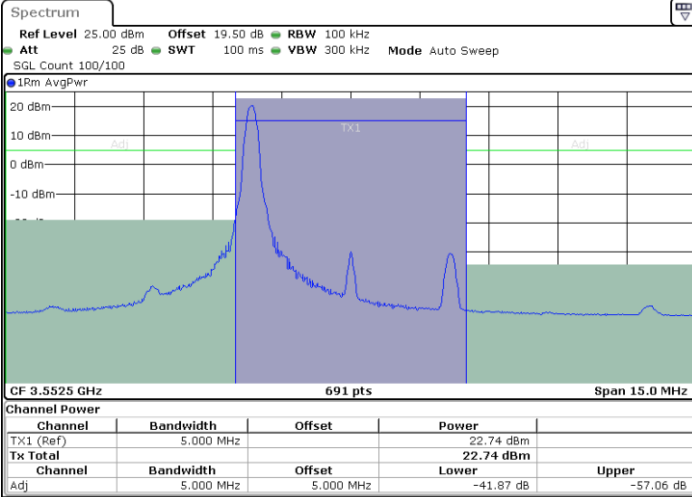

Date: 12.NOV.2024 15:24:54

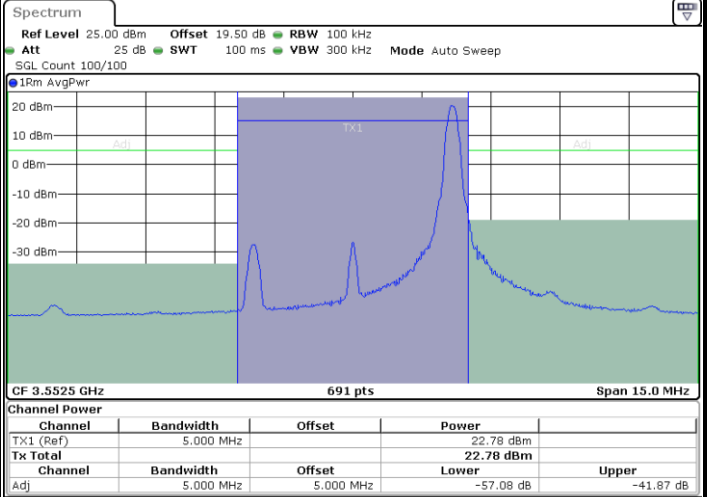

Date: 12.NOV.2024 15:25:38

Lowest Channel / FullIRB

N/A

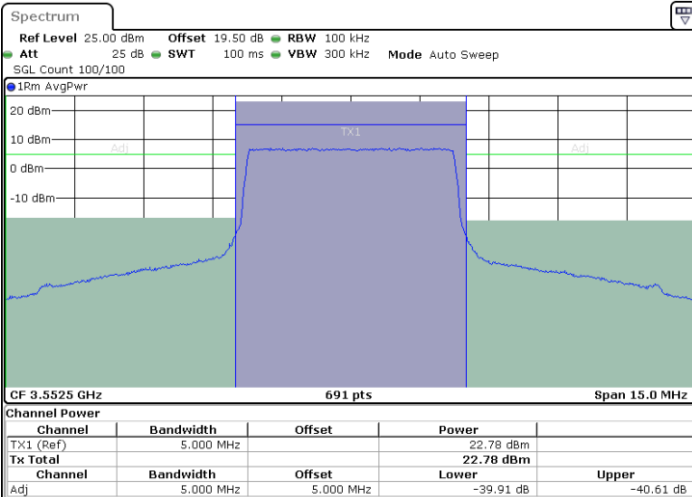

Date: 12.NOV.2024 15:21:13



LTE Band 48 / 5MHz

QPSK

Middle Channel / 1RB0

Middle Channel / 1RBmax

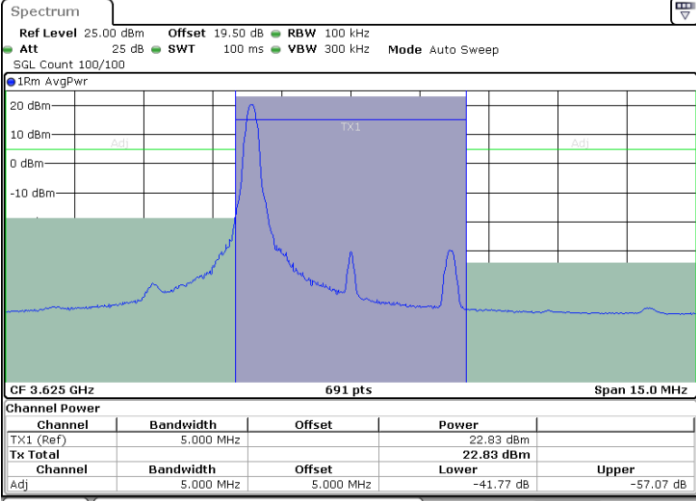

Date: 12.NOV.2024 15:31:17

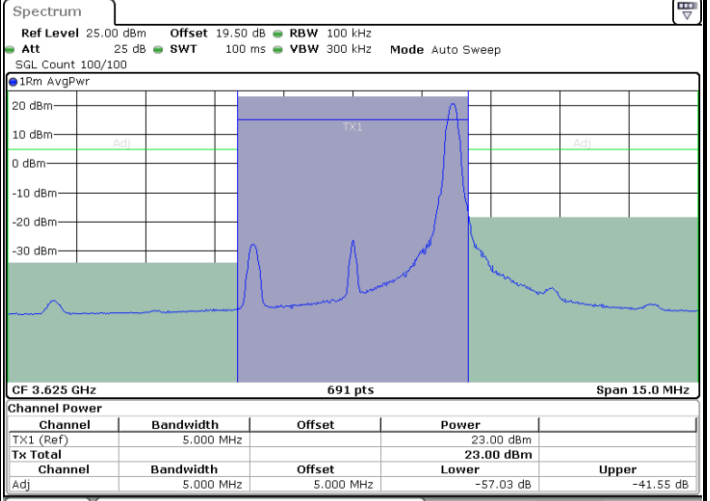

Date: 12.NOV.2024 15:30:33

Middle Channel / FullIRB

N/A

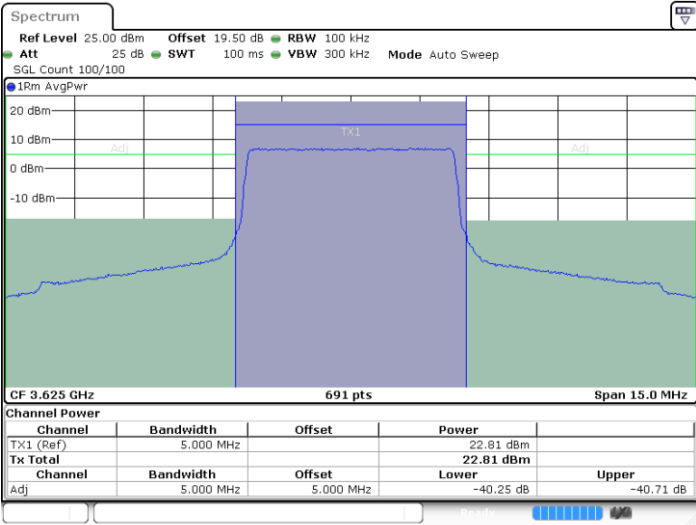

Date: 12.NOV.2024 15:34:55



LTE Band 48 / 5MHz

QPSK

Highest Channel / 1RB0

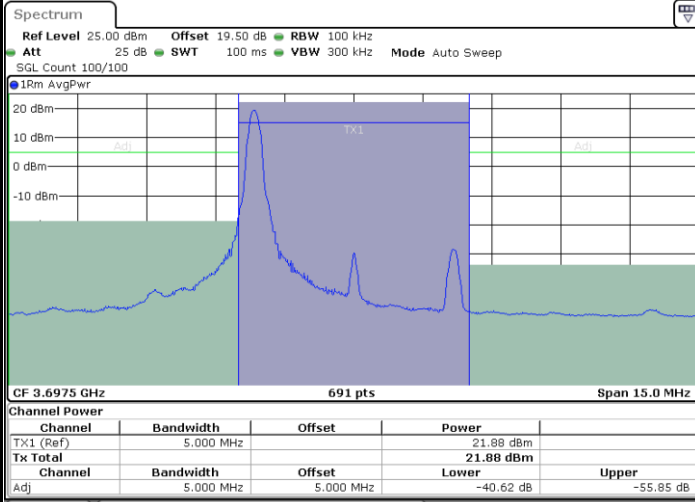

Date: 12.NOV.2024 15:41:19

Highest Channel / 1RBmax

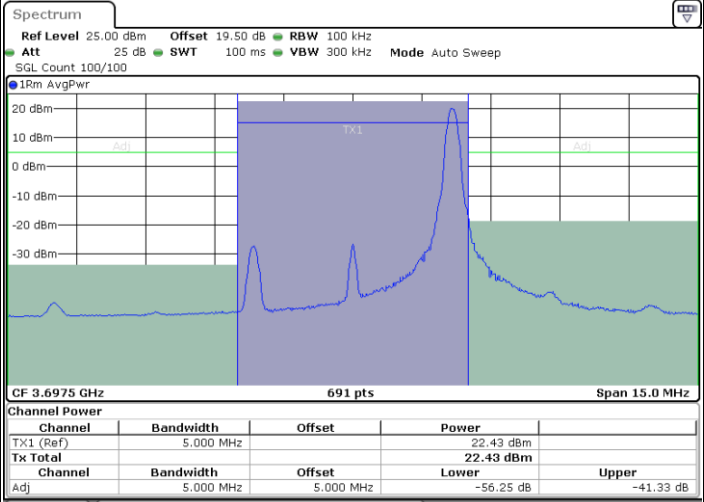

Date: 12.NOV.2024 15:40:35

Highest Channel / FullRB

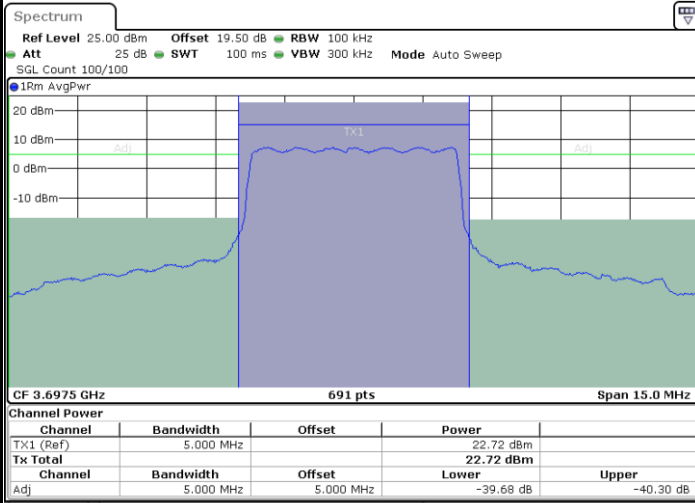

Date: 12.NOV.2024 15:36:54

N/A



LTE Band 48 / 10MHz

QPSK

Lowest Channel / 1RB0

Lowest Channel / 1RBmax

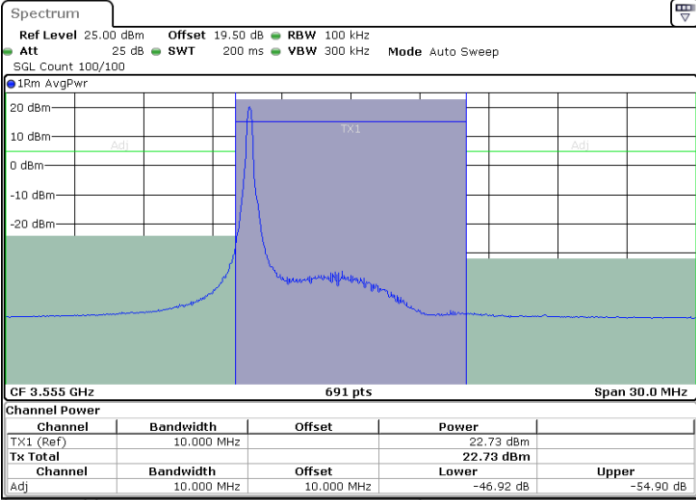

Date: 12.NOV.2024 15:50:06

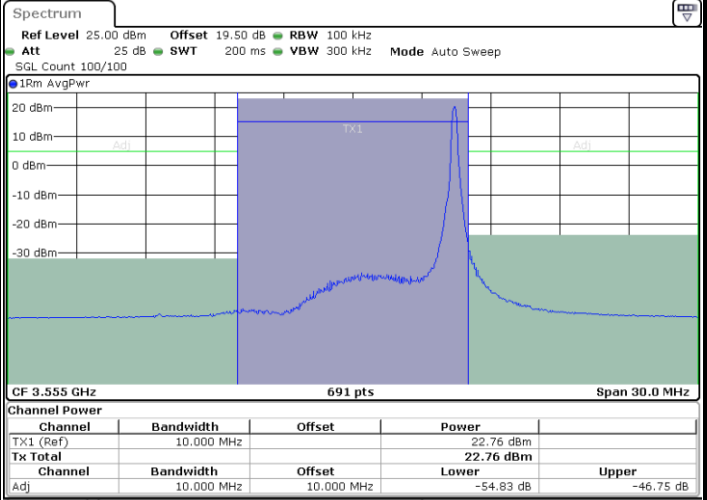

Date: 12.NOV.2024 15:49:20

Lowest Channel / FullIRB

N/A

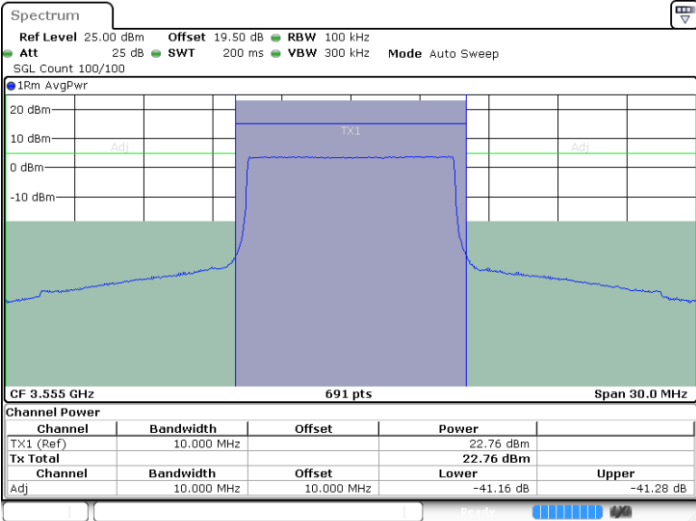

Date: 12.NOV.2024 15:45:32



LTE Band 48 / 10MHz

QPSK

Middle Channel / 1RB0

Middle Channel / 1RBmax

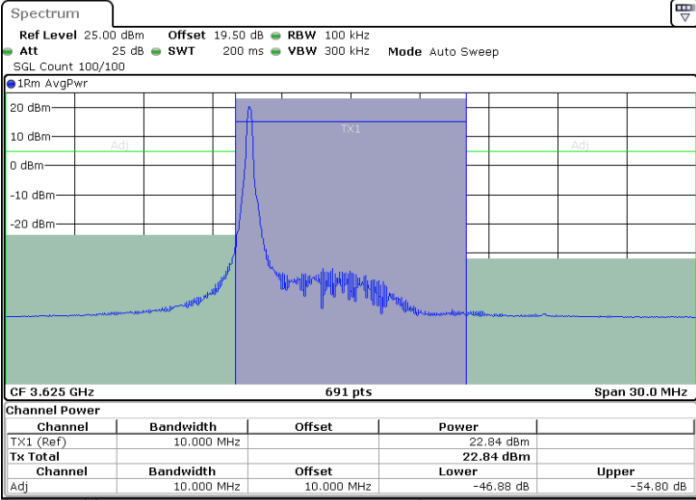

Date: 12.NOV.2024 15:55:11

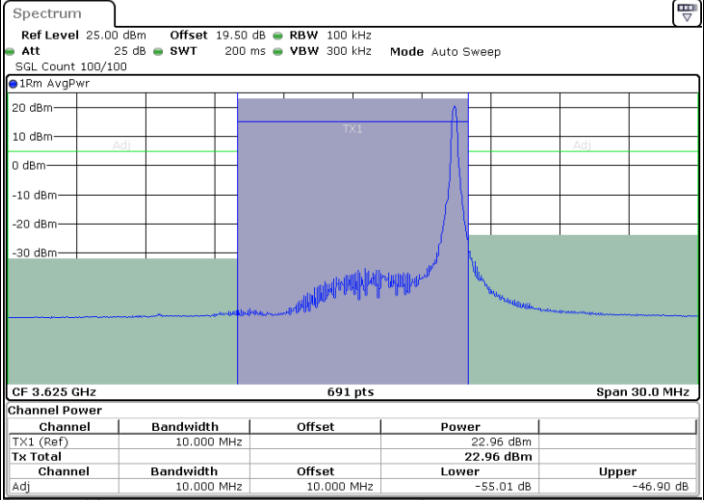

Date: 12.NOV.2024 15:55:56

Middle Channel / FullIRB

N/A

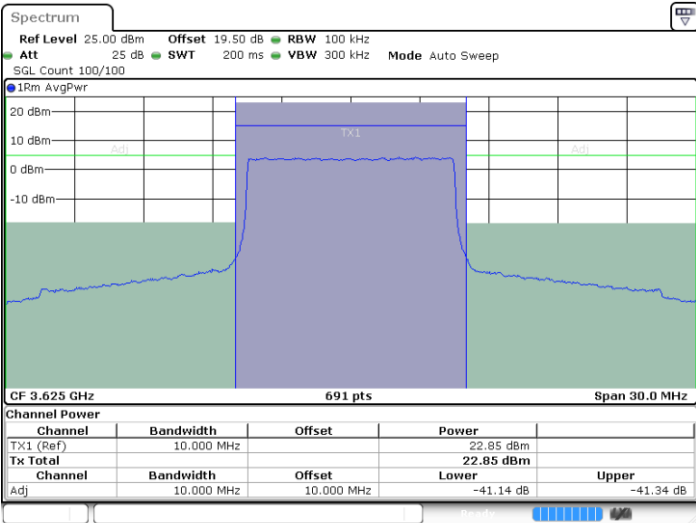

Date: 12.NOV.2024 15:59:42



LTE Band 48 / 10MHz

QPSK

Highest Channel / 1RB0

Highest Channel / 1RBmax

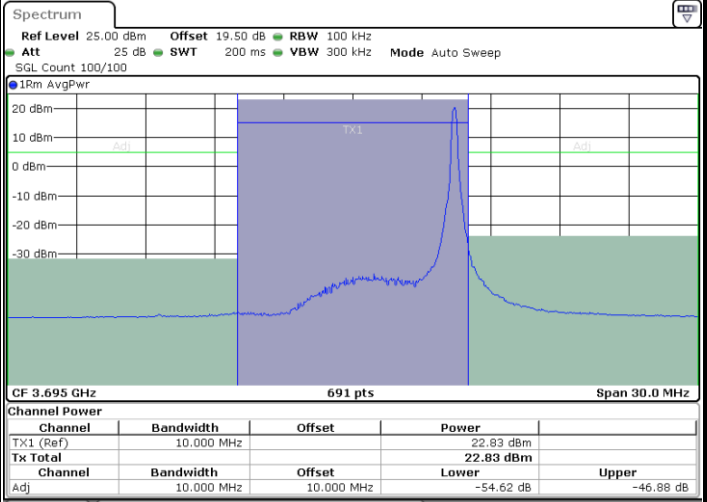
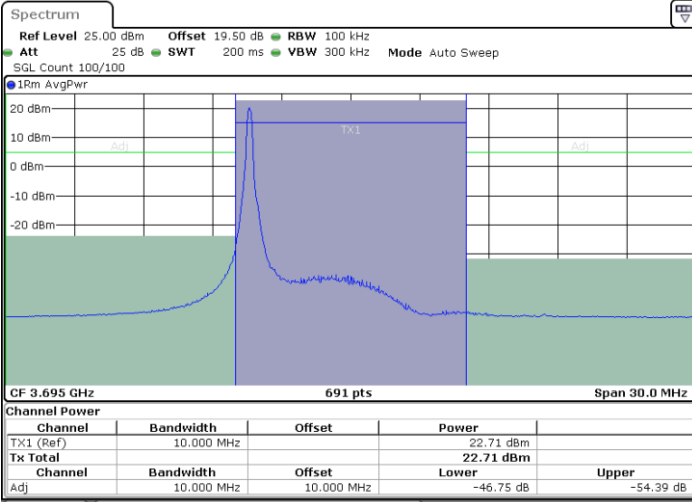

Date: 12.NOV.2024 16:06:22

Date: 12.NOV.2024 16:05:35

Highest Channel / FullRB

N/A

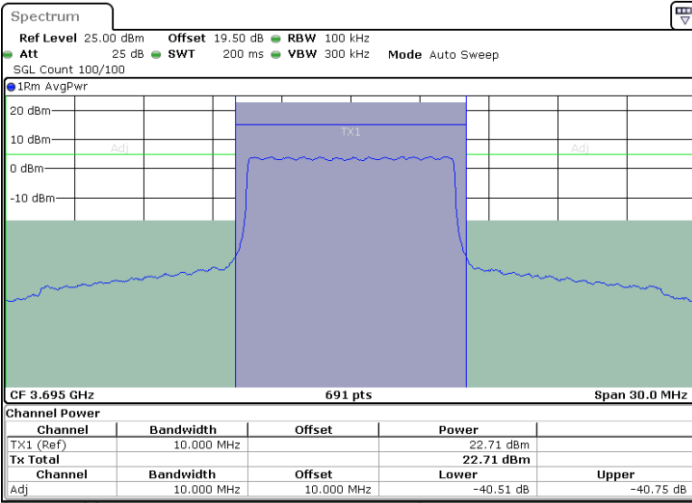

Date: 12.NOV.2024 16:01:43



LTE Band 48 / 15MHz

QPSK

Lowest Channel / 1RB0

Lowest Channel / 1RBmax

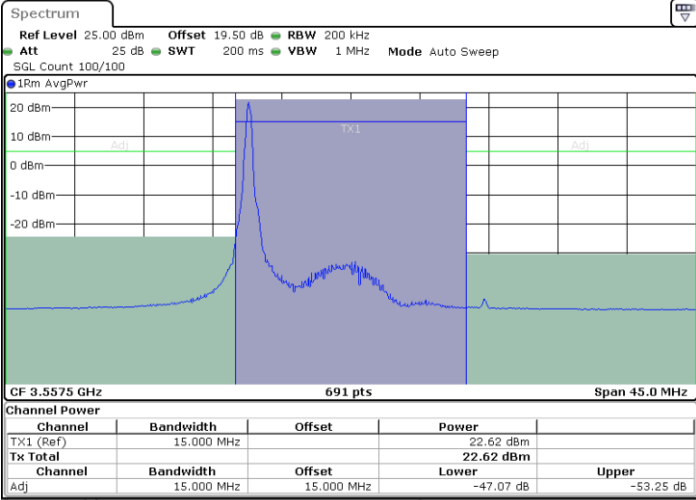

Date: 12.NOV.2024 16:15:57

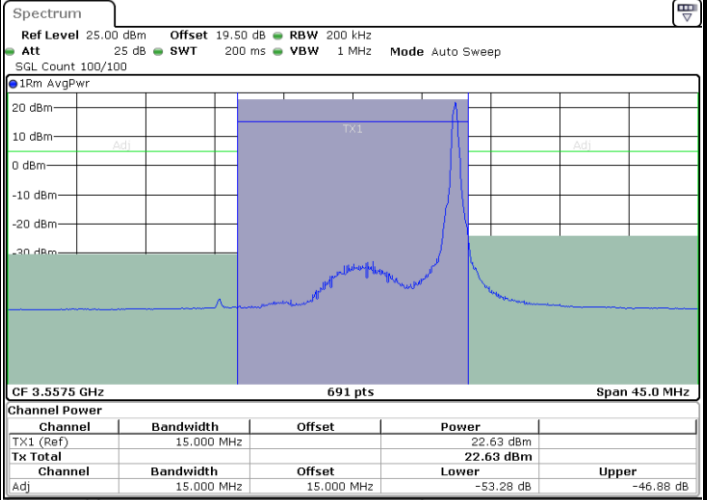

Date: 12.NOV.2024 16:15:11

Lowest Channel / FullIRB

N/A

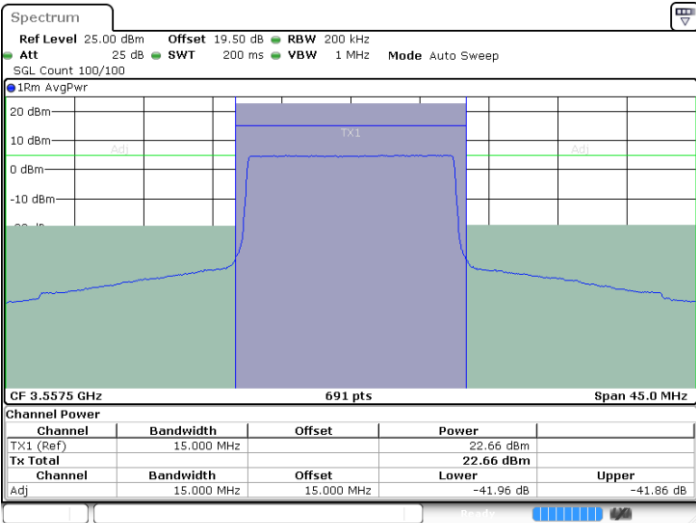

Date: 12.NOV.2024 16:10:39



LTE Band 48 / 15MHz

QPSK

Middle Channel / 1RB0

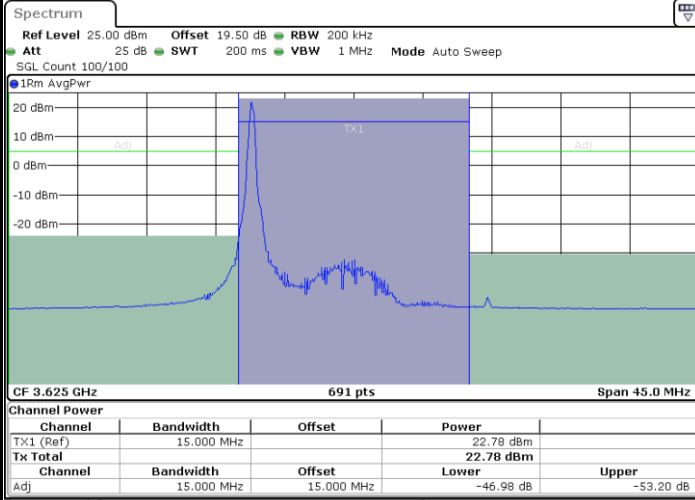

Date: 12.NOV.2024 16:21:00

Middle Channel / 1RBmax

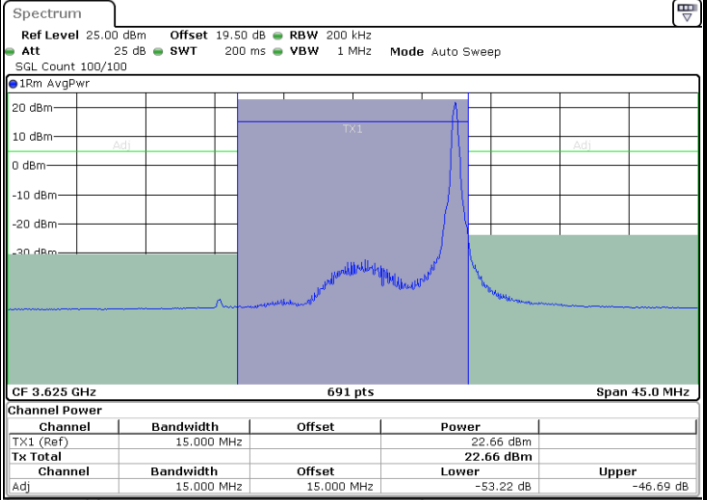

Date: 12.NOV.2024 16:21:45

Middle Channel / FullIRB

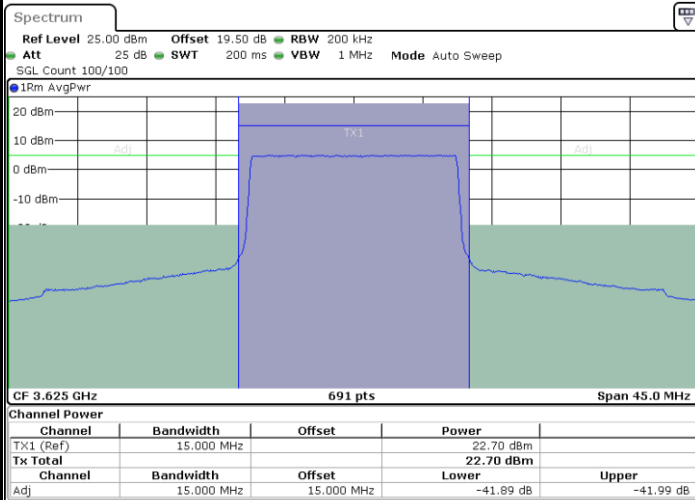

Date: 12.NOV.2024 16:25:30

N/A



LTE Band 48 / 15MHz

QPSK

Highest Channel / 1RB0

Highest Channel / 1RBmax

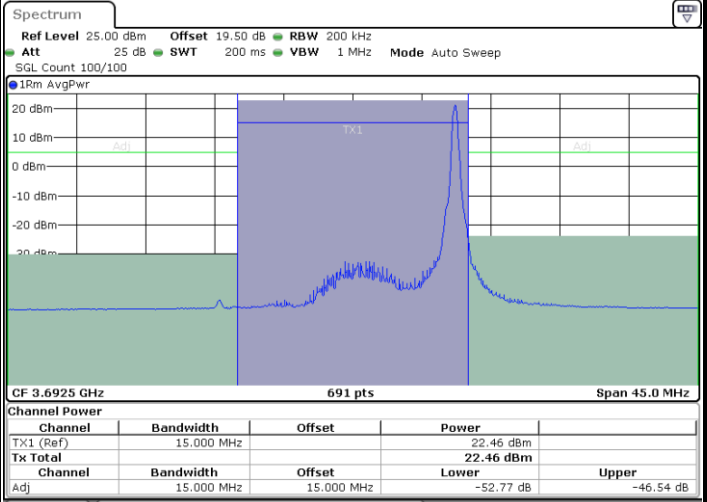
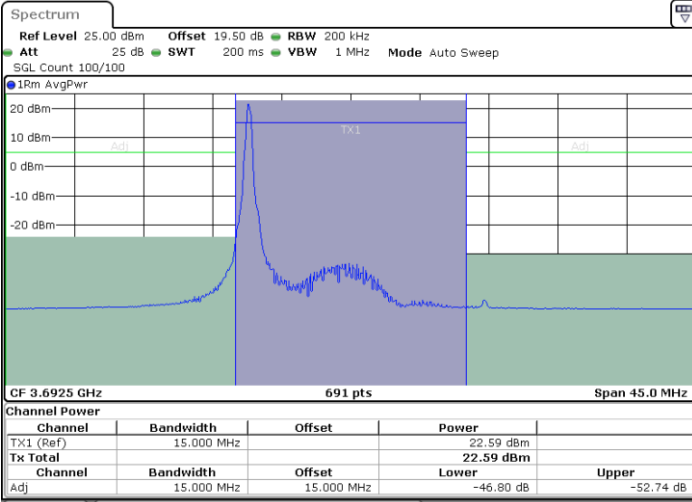

Date: 12.NOV.2024 16:46:06

Date: 12.NOV.2024 16:45:20

Highest Channel / FullRB

N/A

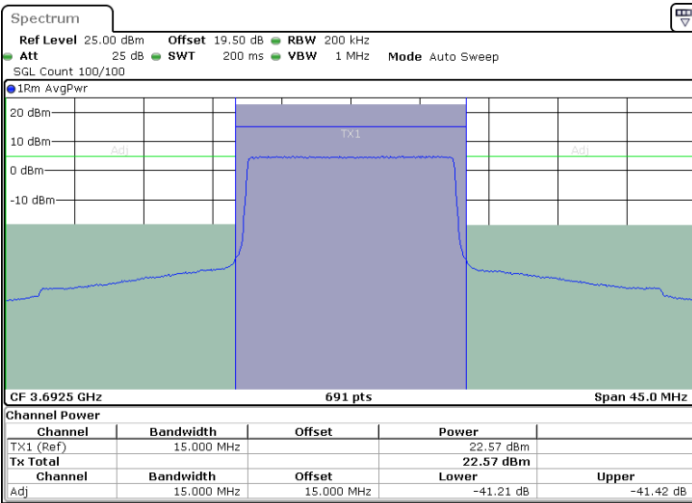

Date: 12.NOV.2024 16:41:28



LTE Band 48 / 20MHz

QPSK

Lowest Channel / 1RB0

Lowest Channel / 1RBmax

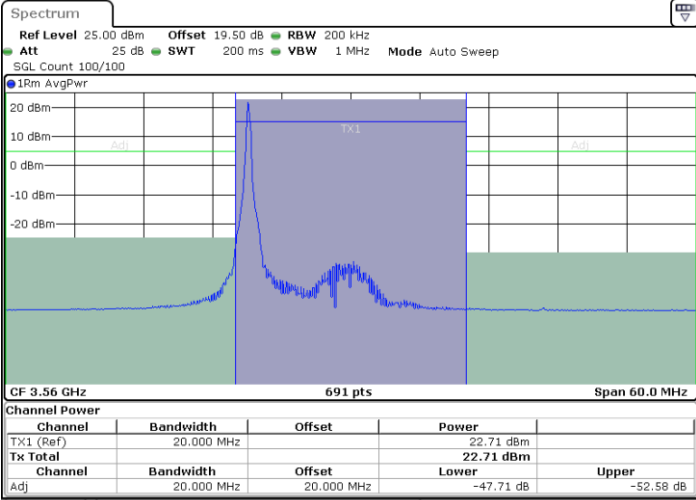

Date: 12.NOV.2024 16:56:22

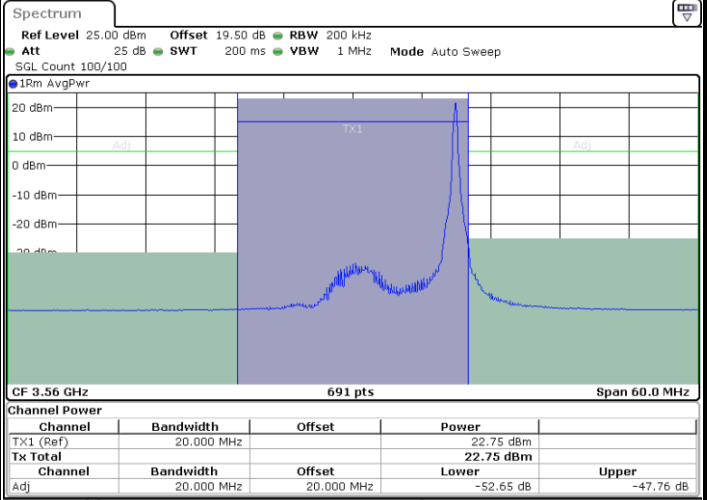

Date: 12.NOV.2024 16:52:37

Lowest Channel / FullIRB

N/A

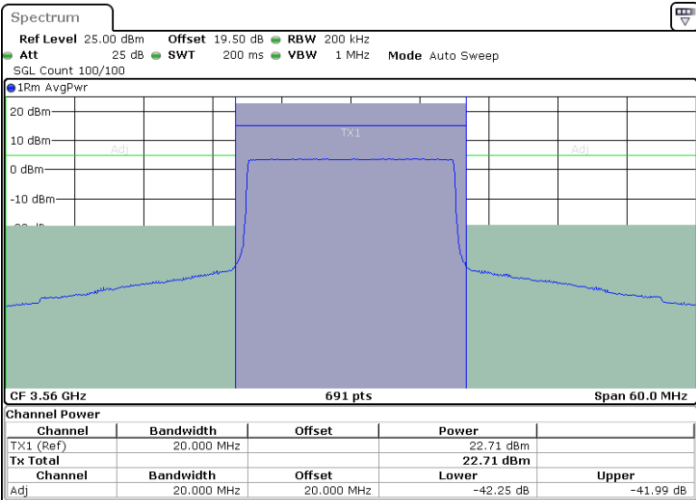

Date: 12.NOV.2024 16:50:22



LTE Band 48 / 20MHz

QPSK

Middle Channel / 1RB0

Middle Channel / 1RBmax

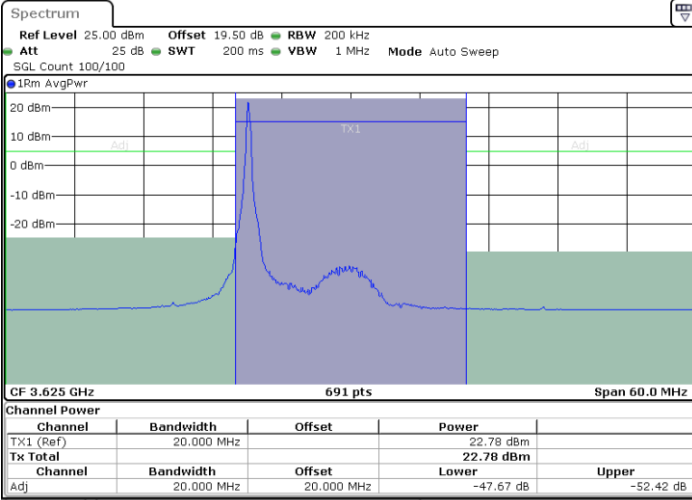

Date: 12.NOV.2024 16:58:10

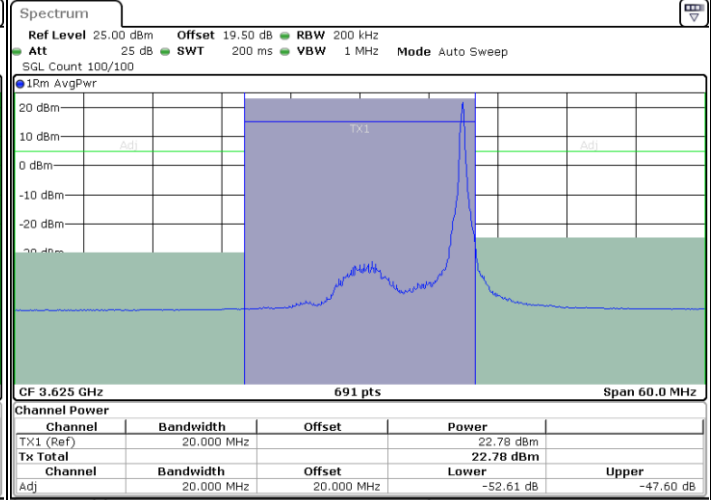

Date: 12.NOV.2024 17:01:51

Middle Channel / FullIRB

N/A

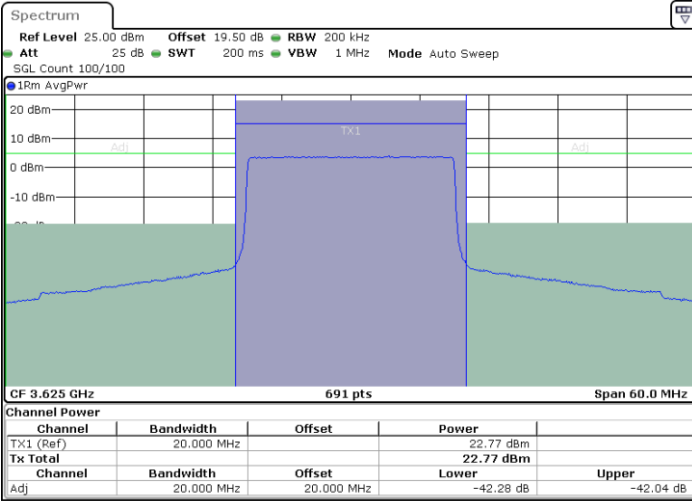

Date: 12.NOV.2024 17:02:36



LTE Band 48 / 20MHz

QPSK

Highest Channel / 1RB0

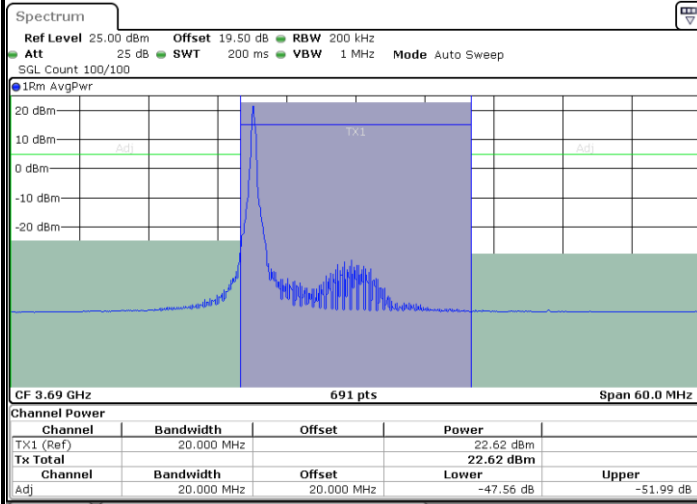

Date: 12.NOV.2024 17:25:42

Highest Channel / 1RBmax

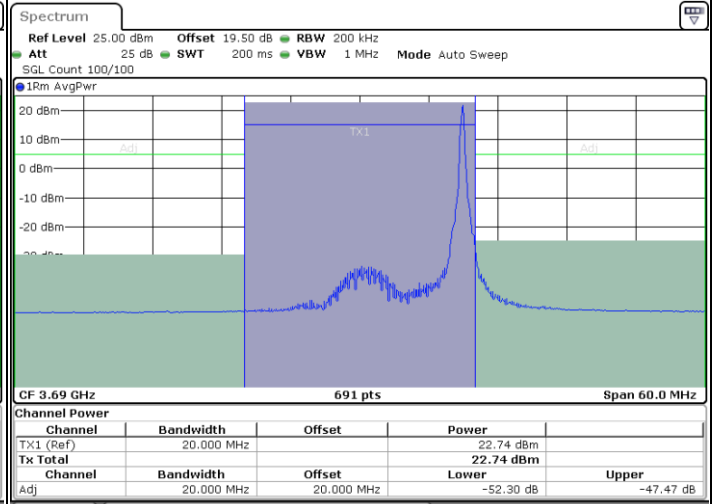

Date: 12.NOV.2024 17:21:57

Highest Channel / FullRB

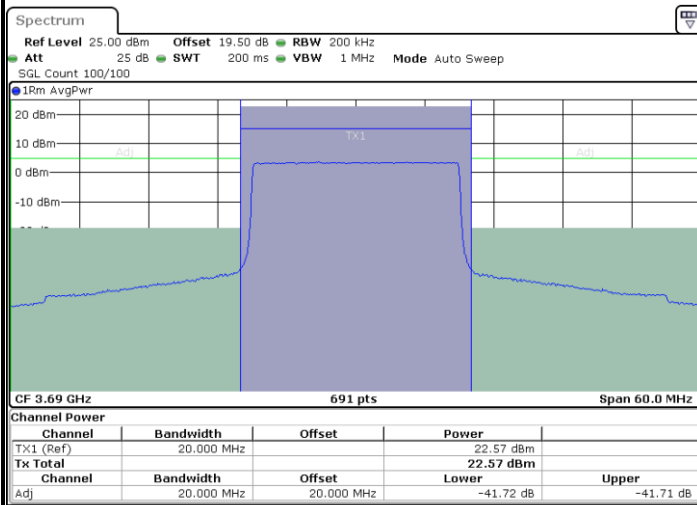

Date: 12.NOV.2024 17:21:12

N/A

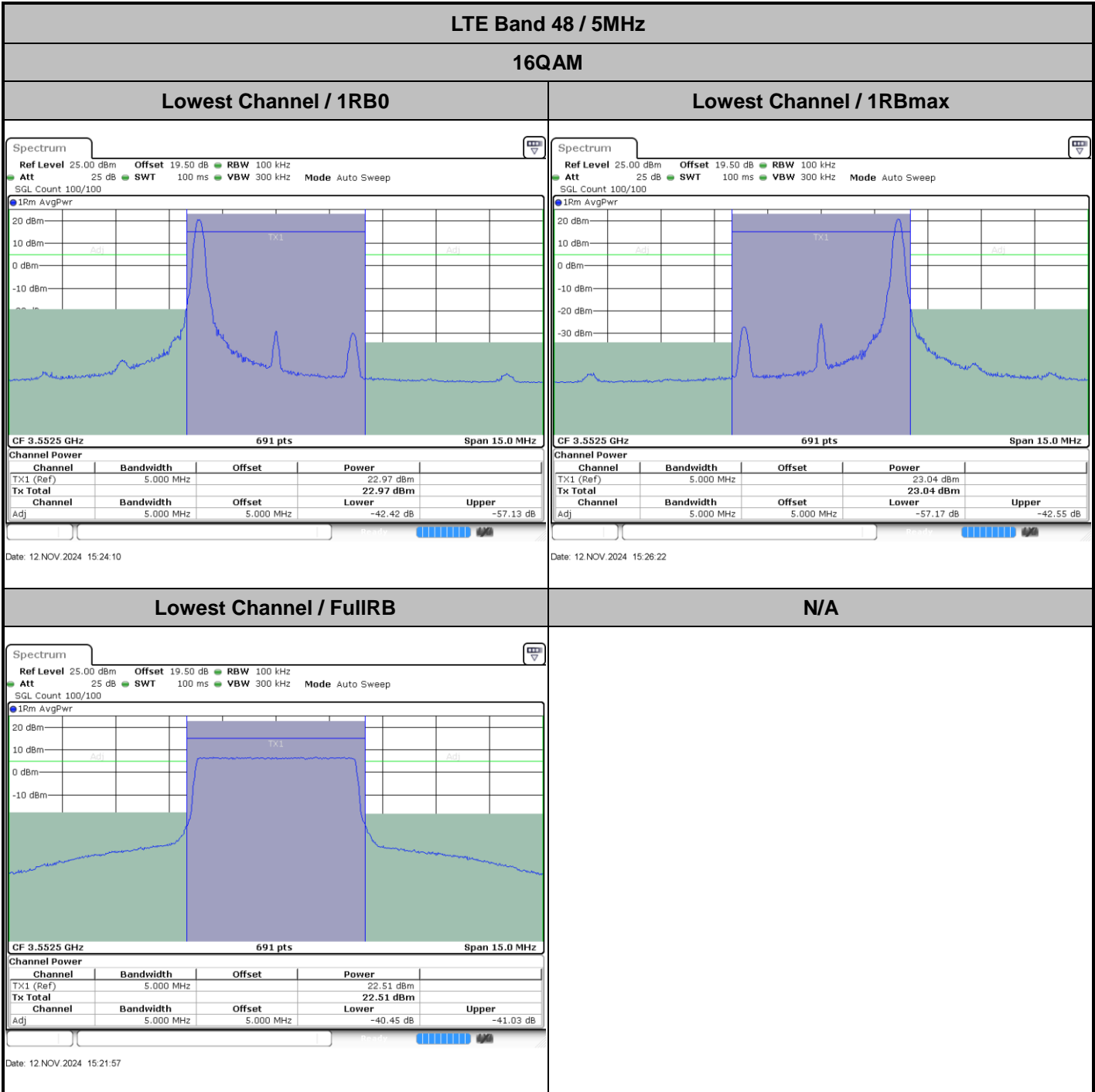



LTE Band 48 / 5MHz

16QAM

Middle Channel / 1RB0

Middle Channel / 1RBmax

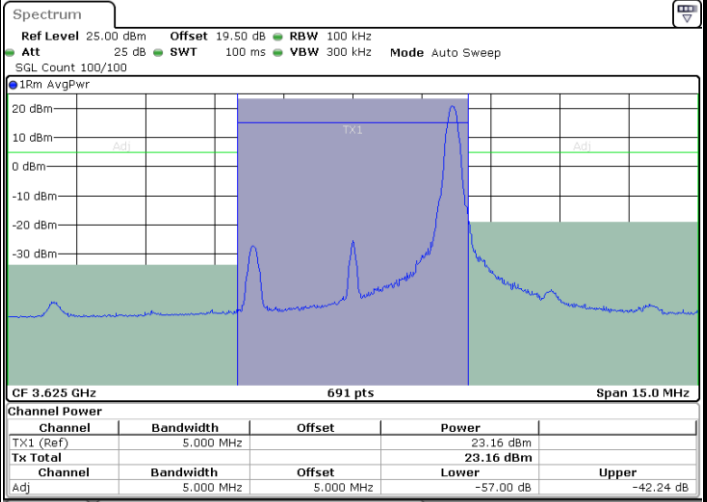
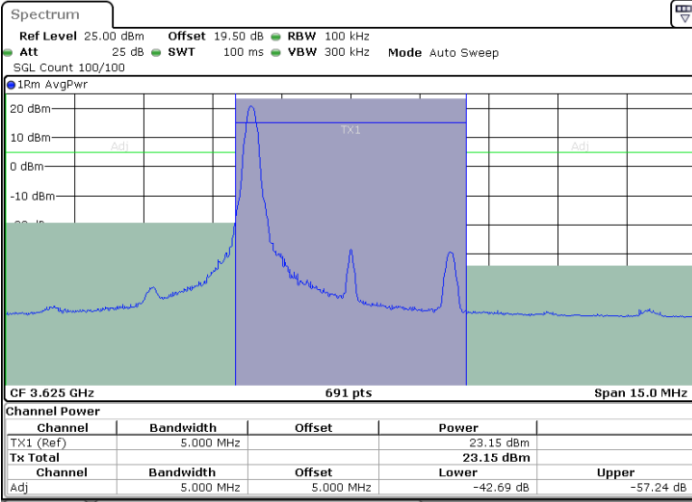

Date: 12.NOV.2024 15:32:00

Date: 12.NOV.2024 15:29:50

Middle Channel / FullIRB

N/A

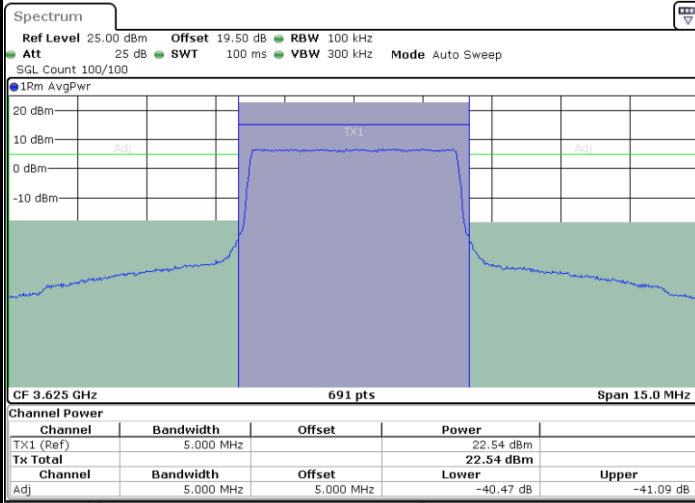

Date: 12.NOV.2024 15:34:11



LTE Band 48 / 5MHz

16QAM

Highest Channel / 1RB0

Highest Channel / 1RBmax

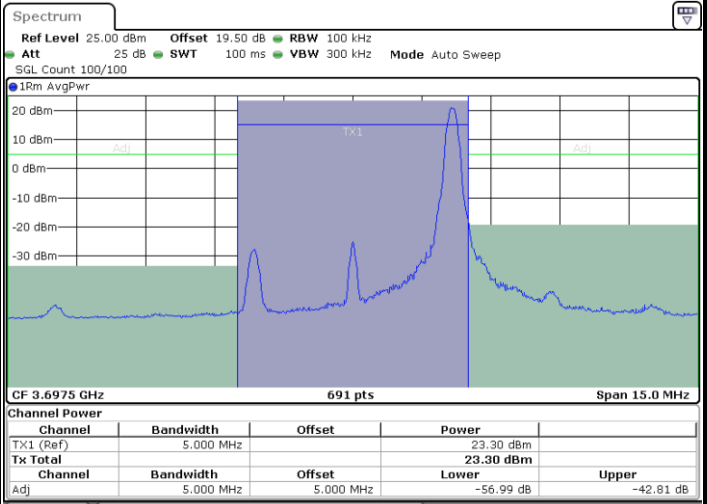
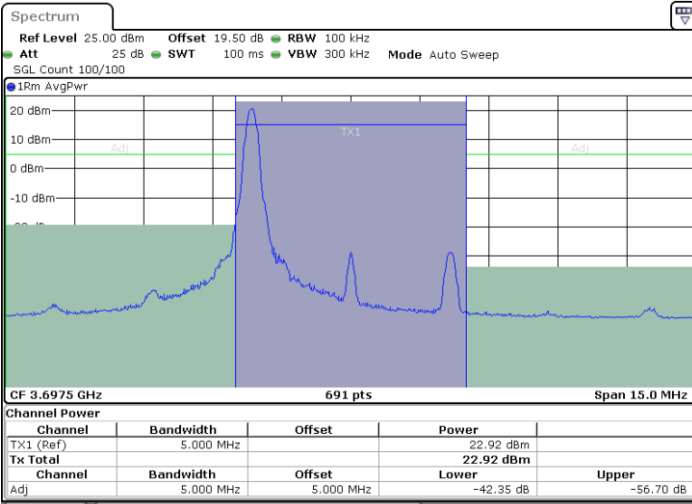

Date: 12.NOV.2024 15:42:04

Date: 12.NOV.2024 15:39:51

Highest Channel / FullRB

N/A

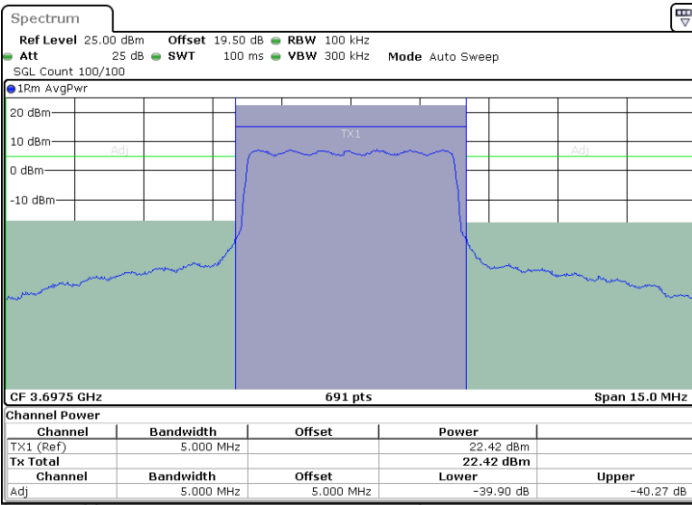

Date: 12.NOV.2024 15:37:38



LTE Band 48 / 10MHz

16QAM

Lowest Channel / 1RB0

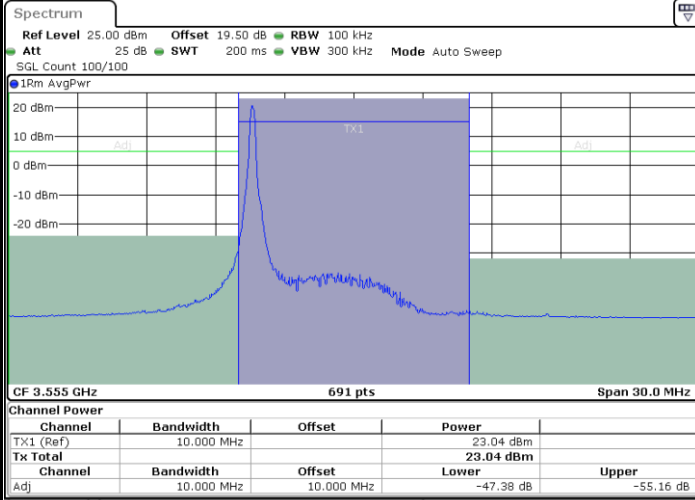

Date: 12.NOV.2024 15:50:51

Lowest Channel / 1RBmax

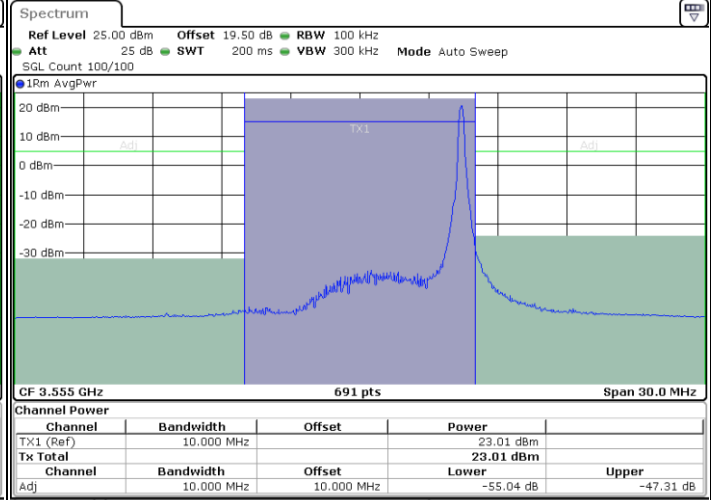

Date: 12.NOV.2024 15:48:35

Lowest Channel / FullIRB

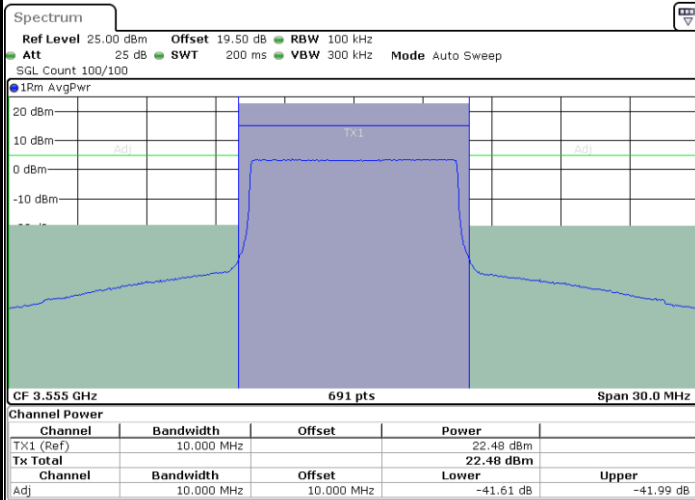

Date: 12.NOV.2024 15:46:18

N/A



LTE Band 48 / 10MHz

16QAM

Middle Channel / 1RB0

Middle Channel / 1RBmax

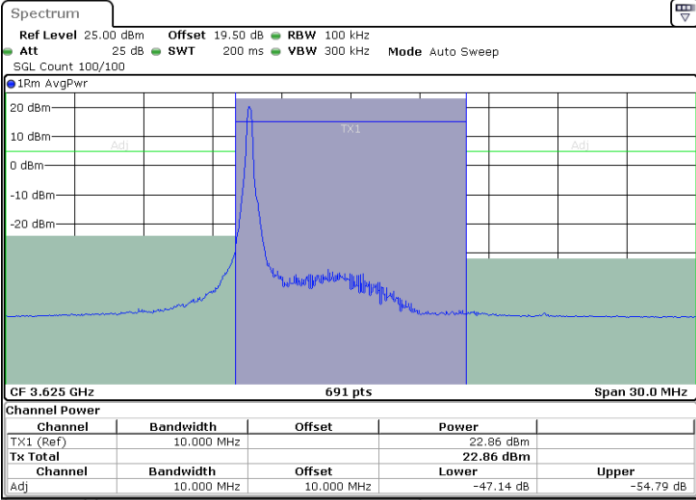

Date: 12.NOV.2024 15:54:26

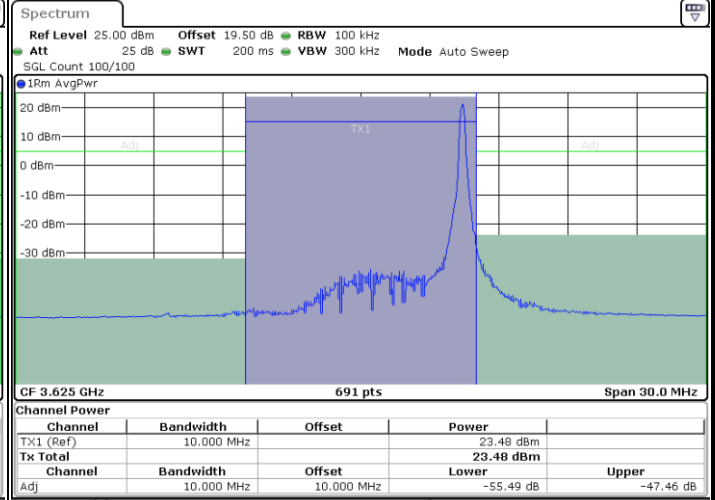

Date: 12.NOV.2024 15:56:41

Middle Channel / FullIRB

N/A

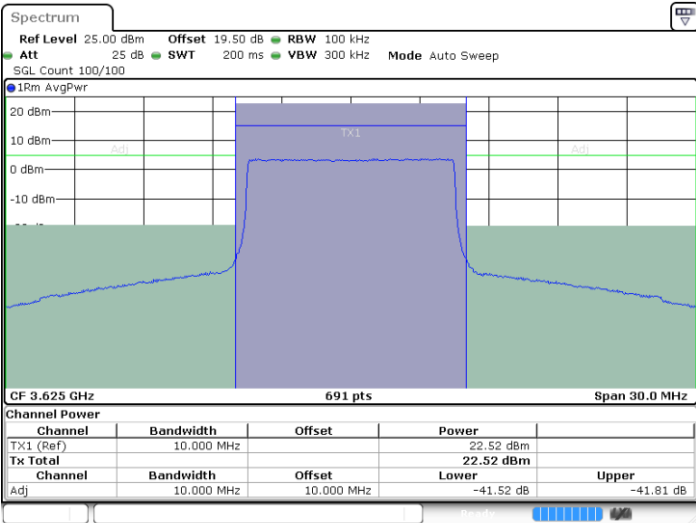

Date: 12.NOV.2024 15:58:57



LTE Band 48 / 10MHz

16QAM

Highest Channel / 1RB0

Highest Channel / 1RBmax

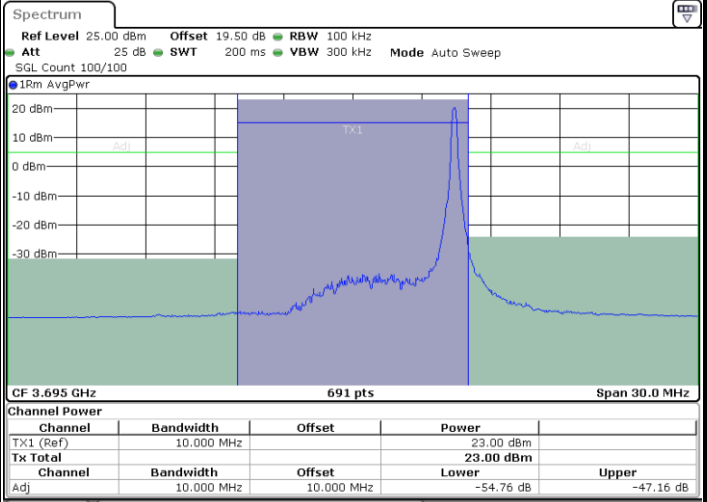
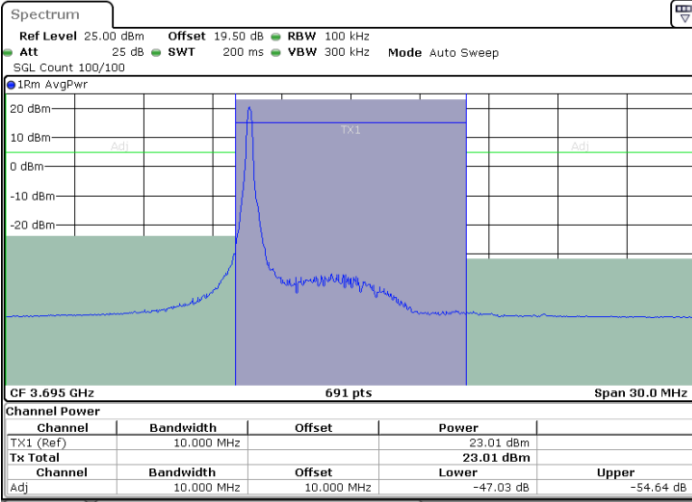

Date: 12.NOV.2024 16:07:08

Date: 12.NOV.2024 16:04:49

Highest Channel / FullRB

N/A

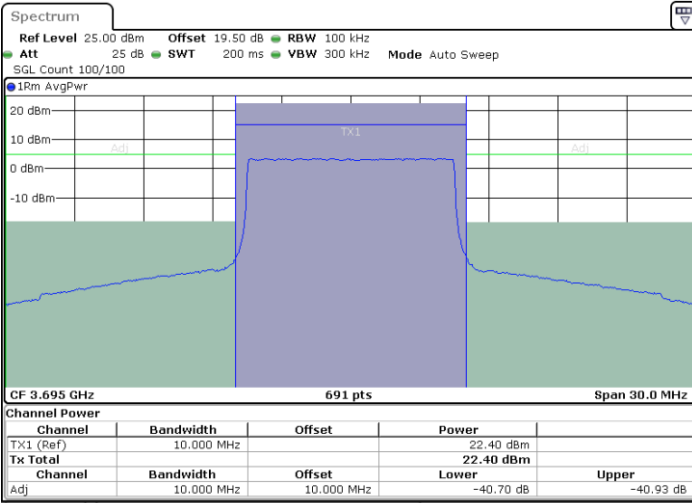

Date: 12.NOV.2024 16:02:30



LTE Band 48 / 15MHz

16QAM

Lowest Channel / 1RB0

Lowest Channel / 1RBmax

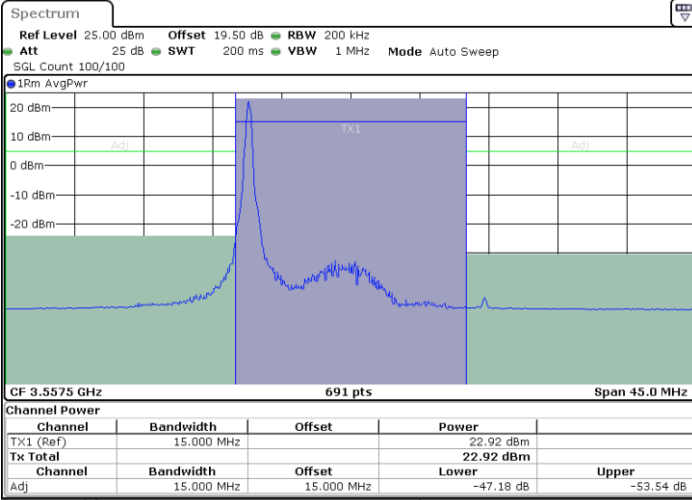

Date: 12.NOV.2024 16:16:43

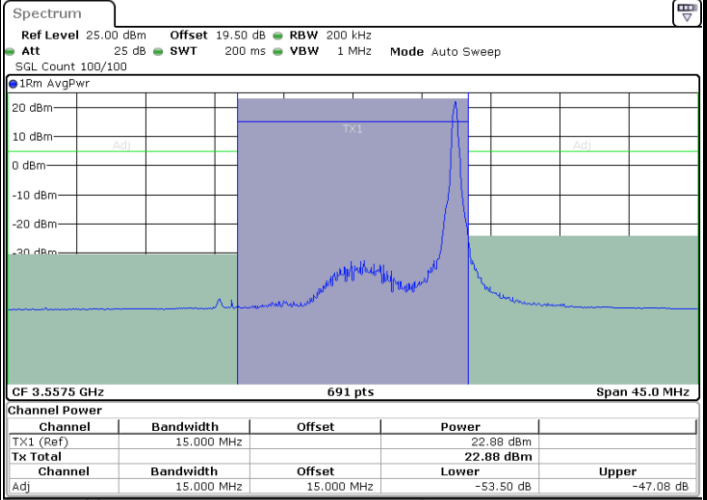

Date: 12.NOV.2024 16:14:26

Lowest Channel / FullIRB

N/A

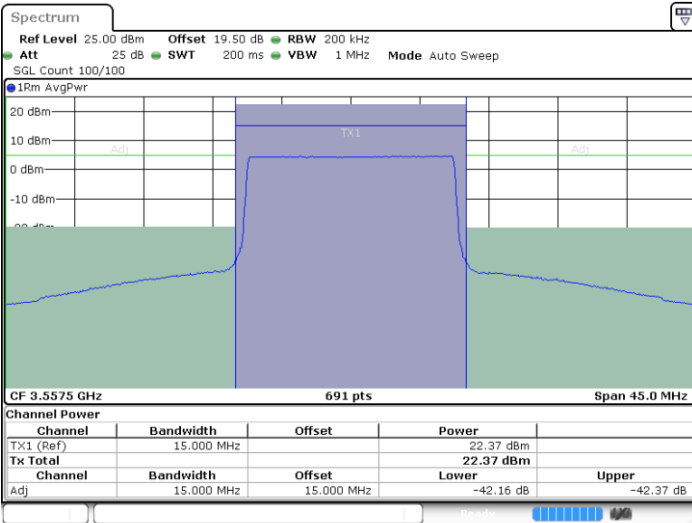

Date: 12.NOV.2024 16:11:24



LTE Band 48 / 15MHz

16QAM

Middle Channel / 1RB0

Middle Channel / 1RBmax

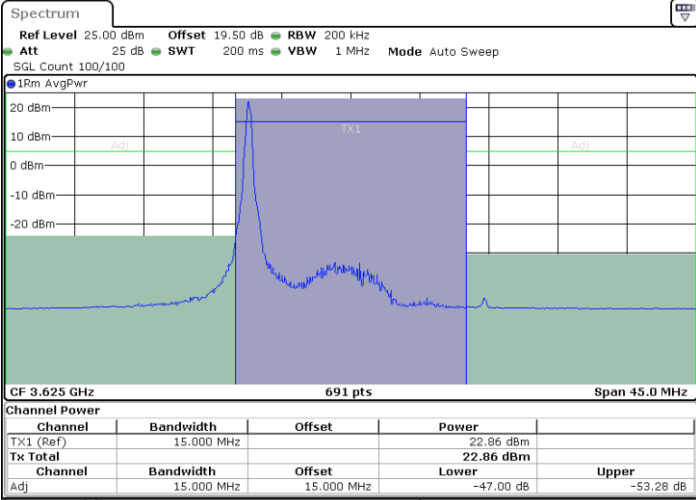

Date: 12.NOV.2024 16:20:15

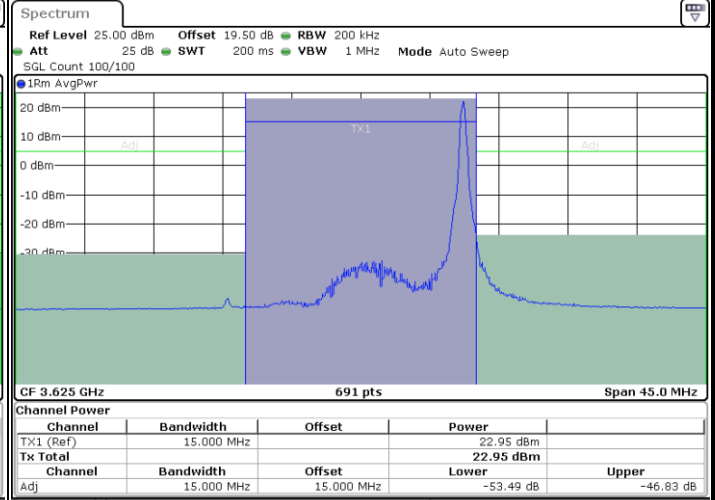

Date: 12.NOV.2024 16:22:30

Middle Channel / FullIRB

N/A

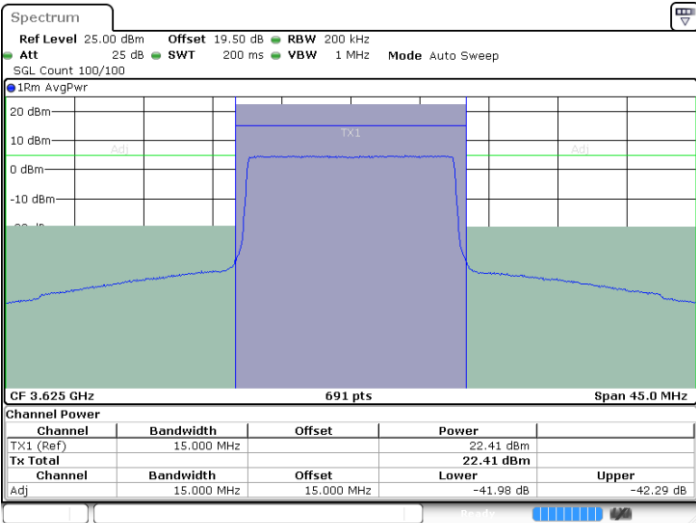

Date: 12.NOV.2024 16:24:45



LTE Band 48 / 15MHz

16QAM

Highest Channel / 1RB0

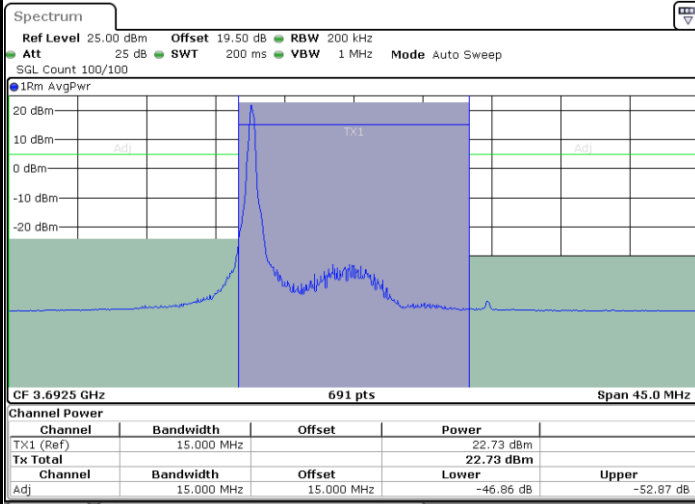

Date: 12.NOV.2024 16:46:52

Highest Channel / 1RBmax

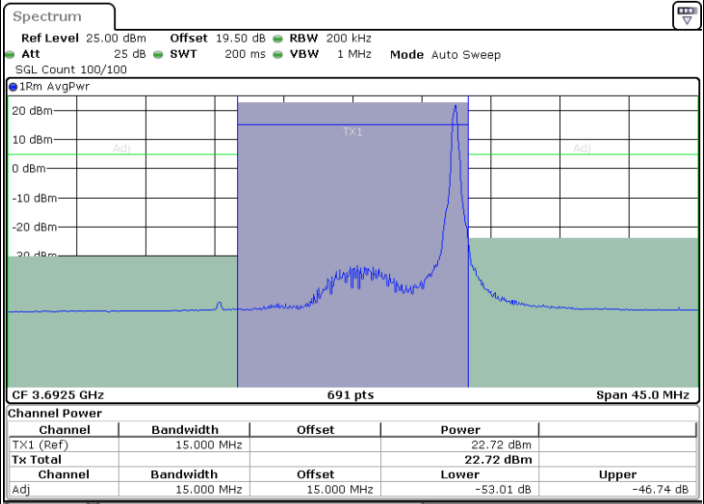

Date: 12.NOV.2024 16:44:33

Highest Channel / FullRB

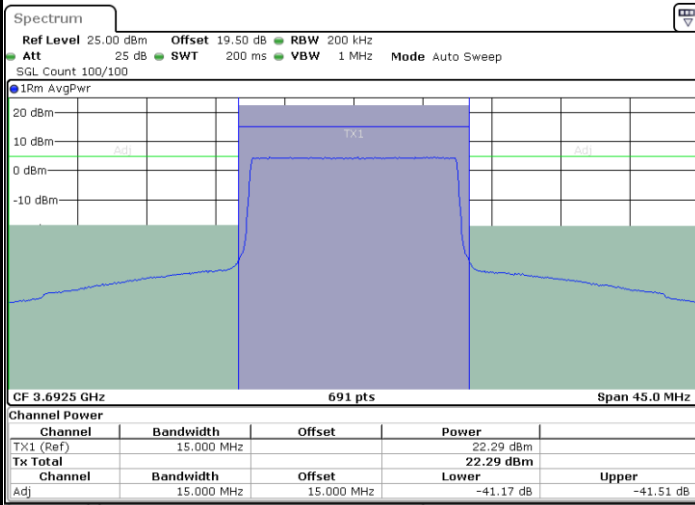

Date: 12.NOV.2024 16:42:14

N/A



LTE Band 48 / 20MHz

16QAM

Lowest Channel / 1RB0

Lowest Channel / 1RBmax

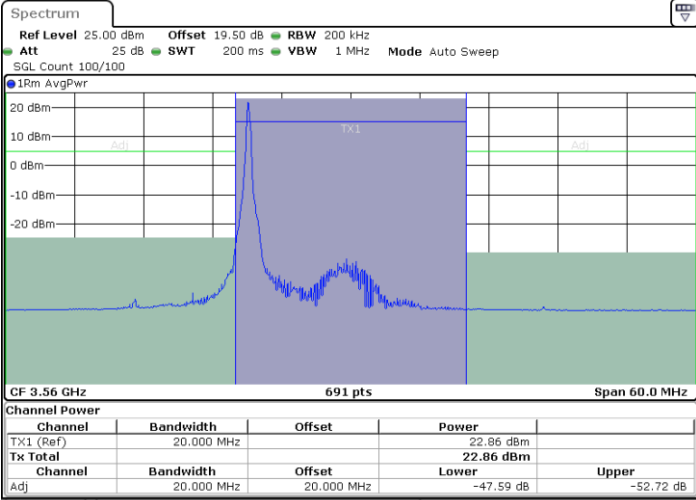

Date: 12.NOV.2024 16:55:37

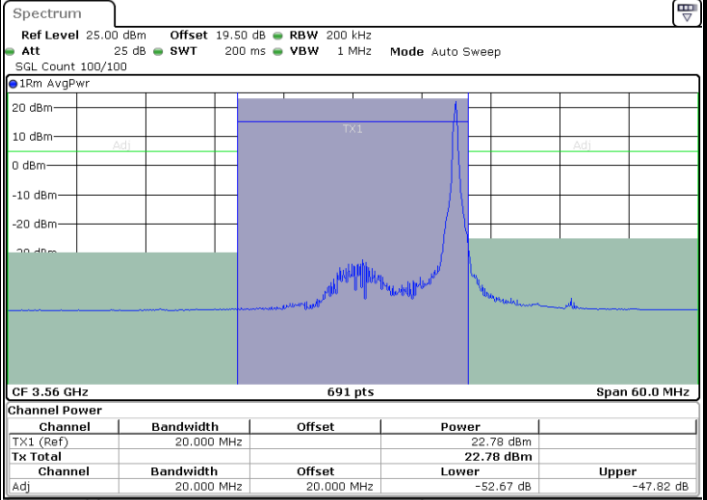

Date: 12.NOV.2024 16:53:22

Lowest Channel / FullIRB

N/A

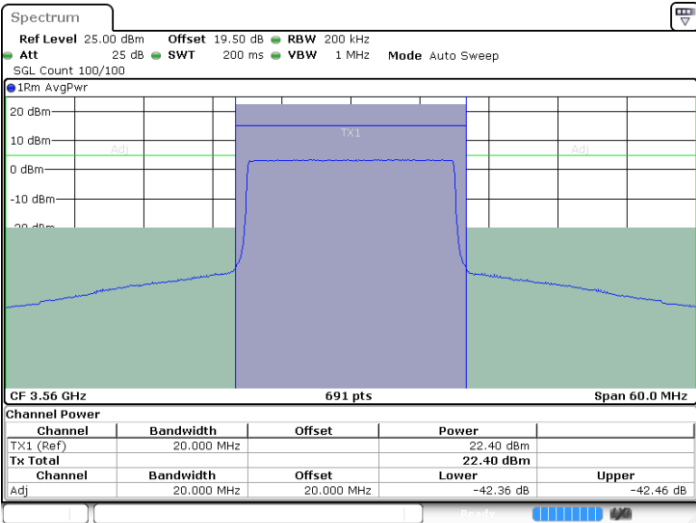

Date: 12.NOV.2024 16:51:07



LTE Band 48 / 20MHz

16QAM

Middle Channel / 1RB0

Middle Channel / 1RBmax

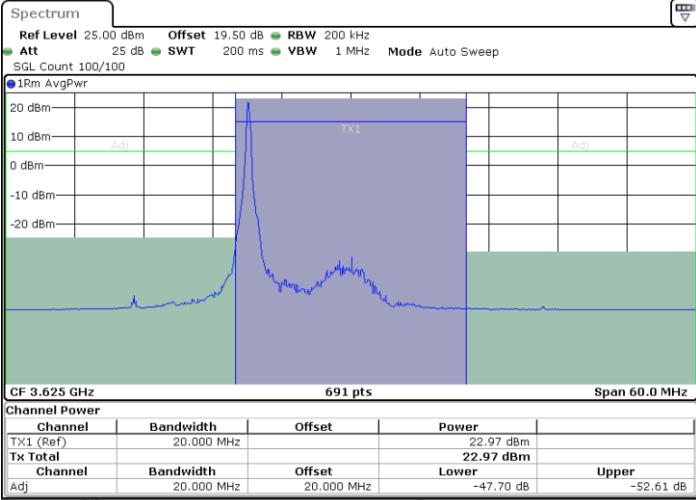

Date: 12.NOV.2024 16:58:54

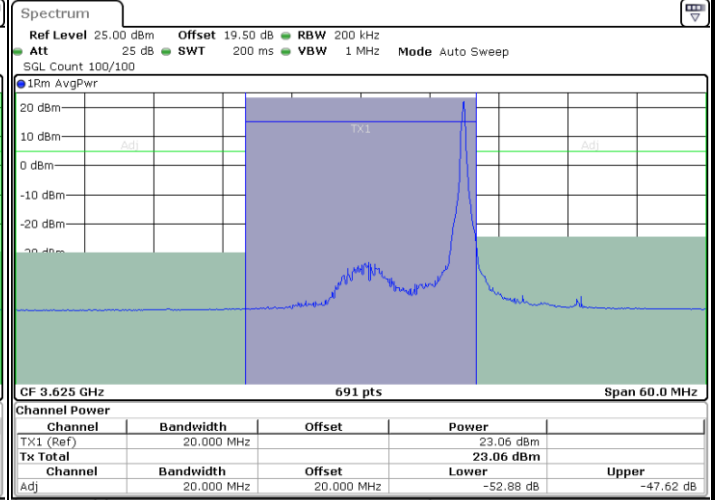

Date: 12.NOV.2024 17:01:07

Middle Channel / FullIRB

N/A

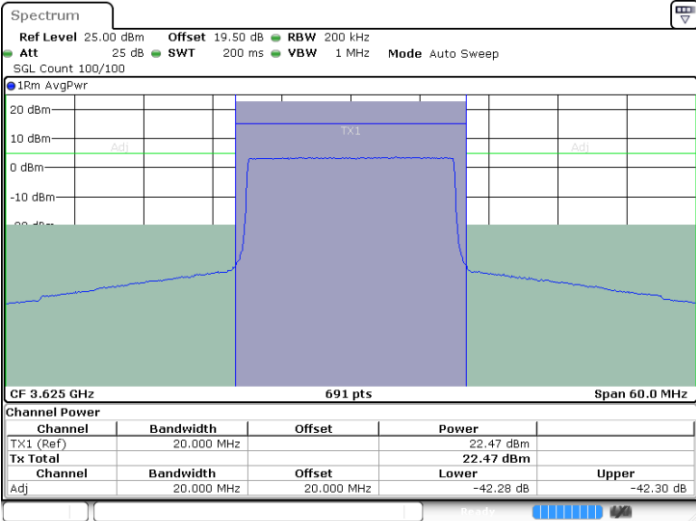

Date: 12.NOV.2024 17:03:20



LTE Band 48 / 20MHz

16QAM

Highest Channel / 1RB0

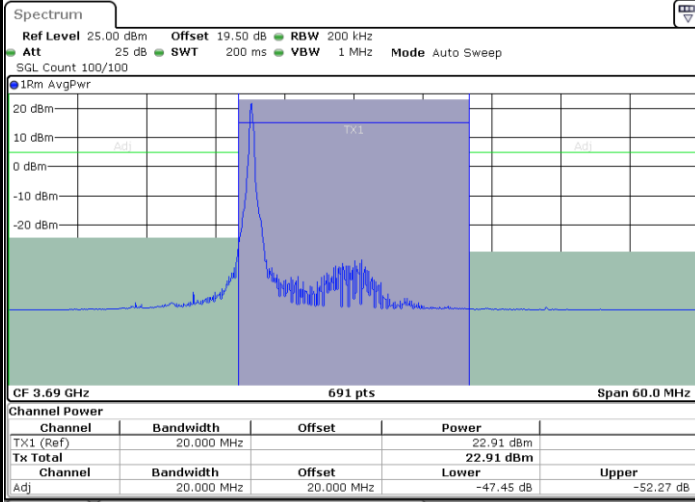

Date: 12.NOV.2024 17:24:57

Highest Channel / 1RBmax

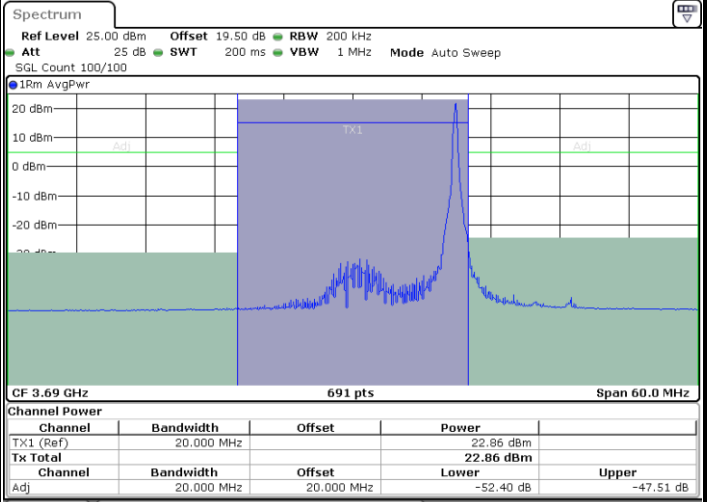

Date: 12.NOV.2024 17:22:42

Highest Channel / FullRB

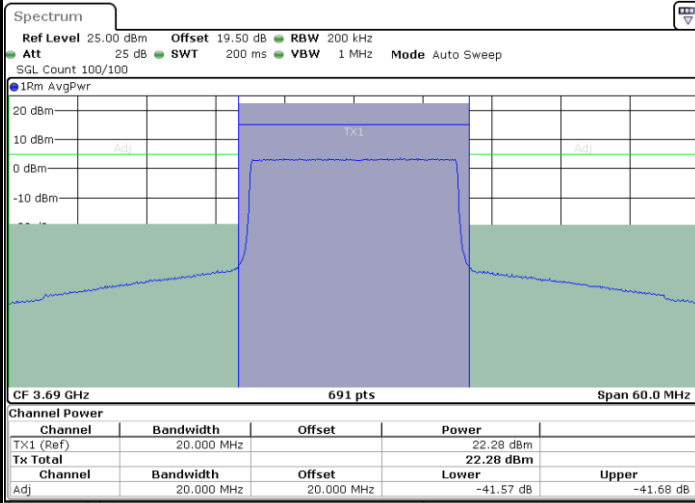

Date: 12.NOV.2024 17:20:28

N/A



LTE Band 48 / 5MHz

64QAM

Lowest Channel / 1RB0

Lowest Channel / 1RBmax

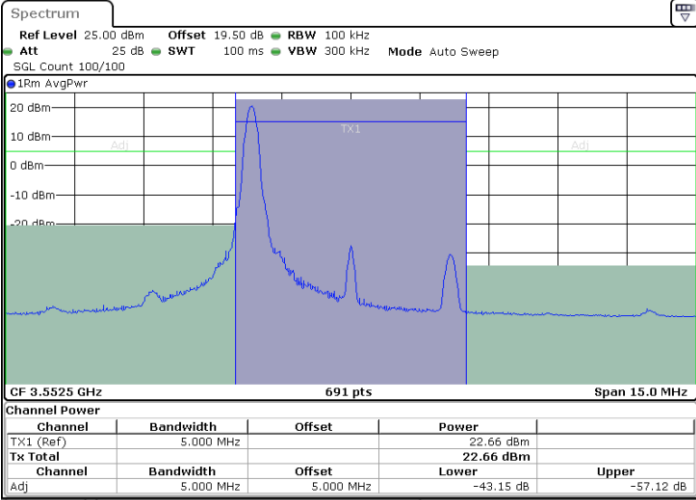

Date: 12.NOV.2024 15:23:25

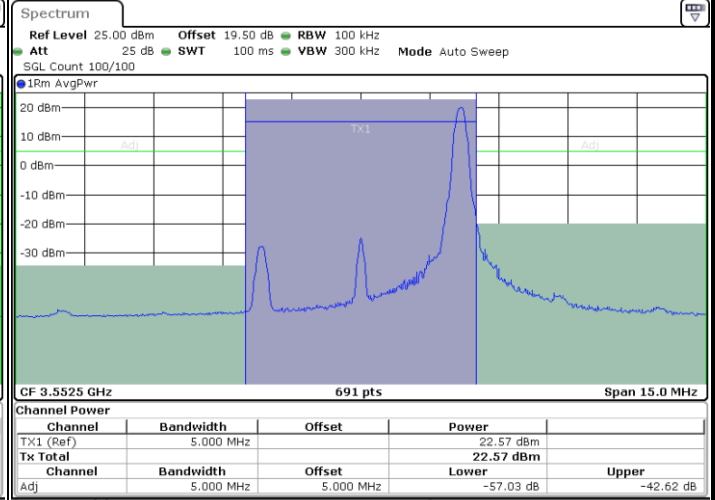

Date: 12.NOV.2024 15:27:06

Lowest Channel / FullIRB

N/A

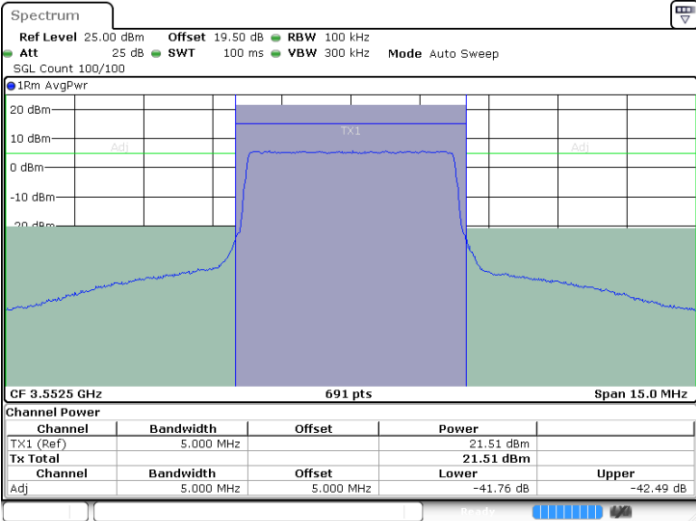

Date: 12.NOV.2024 15:22:41