



FCC RF Test Report

APPLICANT : Motorola Mobility LLC
EQUIPMENT : Mobile Cellular Phone
BRAND NAME : Motorola
MODEL NAME : XT2453-3, XT2453-4, XT2453-5, XT2453V
FCC ID : IHDT56AR7
STANDARD : 47 CFR Part 2, Part 27 Subpart Q
CLASSIFICATION : PCS Licensed Transmitter Held to Ear (PCE)
TEST DATE(S) : Mar. 15, 2024 ~ Mar. 28, 2024

We, Sporton International Inc. (KunShan), would like to declare that the tested sample has been evaluated in accordance with the procedures given in ANSI C63.26-2015 and shown compliance with the applicable technical standards.

The test results in this report apply exclusively to the tested model / sample. Without written approval of Sporton International Inc. (KunShan), the test report shall not be reproduced except in full.

Jason Jia

Approved by: Jason Jia



Sporton International Inc. (ShenZhen)

1/F, 2/F, Bldg 5, Shiling Industrial Zone, Xinwei Village, Xili, Nanshan, Shenzhen, 518055

People's Republic of China



TABLE OF CONTENTS

REVISION HISTORY..... 3
SUMMARY OF TEST RESULT 4
1 GENERAL DESCRIPTION 5
1.1 Applicant..... 5
1.2 Manufacturer..... 5
1.3 Product Feature of Equipment Under Test..... 5
1.4 Product Specification of Equipment Under Test..... 5
1.5 Modification of EUT 6
1.6 Maximum EIRP Power and Emission Designator 6
1.7 Testing Site..... 7
1.8 Test Software..... 8
1.9 Applied Standards 8
1.10 Specification of Accessory..... 8
2 TEST CONFIGURATION OF EQUIPMENT UNDER TEST 9
2.1 Test Mode..... 9
2.2 Connection Diagram of Test System..... 11
2.3 Support Unit used in test configuration and system 11
2.4 Measurement Results Explanation Example..... 11
2.5 Frequency List of Low/Middle/High Channels..... 12
3 CONDUCTED TEST ITEMS 14
3.1 Measuring Instruments 14
3.2 Test Setup 14
3.3 Test Result of Conducted Test 14
3.4 Conducted Output Power Measurement 15
3.5 Peak-to-Average Ratio 16
3.6 EIRP 17
3.7 Occupied Bandwidth..... 18
3.8 Conducted Band Edge Measurement 19
3.9 Conducted Spurious Emission Measurement 20
3.10 Frequency Stability Measurement..... 21
4 RADIATED TEST ITEMS 22
4.1 Measuring Instruments 22
4.2 Test Setup 22
4.3 Test Result of Radiated Test 23
4.4 Radiated Spurious Emission Measurement 24
5 LIST OF MEASURING EQUIPMENT 25
6 MEASUREMENT UNCERTAINTY 26
APPENDIX A. TEST RESULTS OF CONDUCTED TEST
APPENDIX B. TEST RESULTS OF RADIATED TEST
APPENDIX C. TEST SETUP PHOTOGRAPHS



SUMMARY OF TEST RESULT

Report Section	FCC Rule	Description	Limit	Result	Remark
3.4	§2.1046	Conducted Output Power	—	Report Only	-
3.5	§27.50 (k)(4)	Peak-to-Average Ratio	<13dB	PASS	
3.6	§27.50 (k)(3)	EIRP	EIRP < 1W (30dBm)	PASS	-
3.7	§2.1049	Occupied Bandwidth	—	Report Only	-
3.8	§2.1051 §27.53 (n)(2)	Conducted Band Edge Measurement	-13dBm/MHz	PASS	-
3.9	§2.1051 §27.53 (n)(2)	Conducted Spurious Emission	-13dBm/MHz	PASS	-
3.10	§2.1055 §27.54	Frequency Stability Temperature & Voltage	Within the band	PASS	-
4.4	§2.1053 §27.53 (n)(2)	Radiated Spurious Emission	-13dBm/MHz	PASS	Under limit 35.9 dB at 6900.00 MHz

Conformity Assessment Condition:

1. The test results (PASS/FAIL) with all measurement uncertainty excluded are presented against the regulation limits or in accordance with the requirements stipulated by the applicant/manufacturer who shall bear all the risks of non-compliance that may potentially occur if measurement uncertainty is taken into account.
2. The measurement uncertainty please refer to each test result in the section "Measurement Uncertainty"

Disclaimer:

The product specifications of the EUT presented in the test report that may affect the test assessments are declared by the manufacturer who shall take full responsibility for the authenticity.



1 General Description

1.1 Applicant

Motorola Mobility LLC
222 W,Merchandise Mart Plaza, Chicago IL 60654 USA

1.2 Manufacturer

Motorola Mobility LLC
222 W,Merchandise Mart Plaza, Chicago IL 60654 USA

1.3 Product Feature of Equipment Under Test

Product Feature	
Equipment	Mobile Cellular Phone
Brand Name	Motorola
Model Name	XT2453-3, XT2453-4, XT2453-5, XT2453V
FCC ID	IHDT56AR7
IMEI Code	Conducted : 358394210026253/358394210026261 Radiation : 358394210031030/358394210031048
HW Version	DVT2
SW Version	U3UC34.22
EUT Stage	Identical Prototype

Note: The four model names are only for market segment, no other difference.

1.4 Product Specification of Equipment Under Test

Product Feature	
Tx/Rx Frequency	5G NR n77: 3450 MHz ~ 3550 MHz 5G NR n78: 3450 MHz ~ 3550 MHz
SCS	15kHz, 30kHz
Bandwidth	n77/n78 (15kHz): 10 / 15 / 20 / 25 / 30 / 40 / 50MHz n77/n78 (30kHz): 10 / 15 / 20 / 25 / 30 / 40 / 50 / 60 / 70 / 80 / 90 / 100MHz
Antenna Gain	<Ant. 3> 5G NR n77: -5.82 dBi 5G NR n78: -5.82 dBi <Ant. 4> 5G NR n77: -1.89 dBi 5G NR n78: -1.89 dBi <Ant. 6> 5G NR n77: -2.96 dBi 5G NR n78: -2.96 dBi <Ant. 8> 5G NR n77: -3.0 dBi 5G NR n78: -3.0 dBi
Type of Modulation	CP-OFDM: QPSK / 16QAM / 64QAM / 256QAM DFT-s-OFDM: PI/2 BPSK / QPSK / 16QAM / 64QAM / 256QAM

Remark:

1. The maximum EIRP is calculated from max output power and max antenna gain, only the maximum EIRP of Ant.4 for n77/n78 SISO, and Ant.(4+6) for n77/n78 MIMO are shown in the report.
2. The device supports n77/n78(1T4R) SRS resources on Antenna 3/4/6/8, only the test data of worst Antenna 4 is showed in the report according to the maximum power.
3. The device supports HPUE(PC2) for 5G NR n77/n78 SISO mode, HPUE(PC2) for 5G NR n78 MIMO mode, and HPUE(PC1.5) for n77 MIMO mode.
4. 5G NR n77/n78 UL_MIMO mode only supports CP-OFDM Modulation, n77 UL MIMO PC1.5 is correlated, the n77 MIMO Antenna gain = $10 \log[(10^{G1/20} + 10^{G2/20})^2 / 2]$. n78 UL MIMO PC2 is uncorrelated, the n78 MIMO Antenna gain is the maximum gain from the MIMO Antenna. The conducted BE/Spurious are tested at single antenna port and add $10 \cdot \log(N_{ANT})$ according to KDB 662911 D01.
5. 5G NR n77/n78 support UL MIMO mode for Ant(4+8) / Ant(4+6), only the worst test data of Ant(4+6) is shown in the report.
6. 5G NR n77/n78 support SA and NSA mode. The whole testing has assessed SA mode for n77 by referring to the higher conducted power for conducted test items.
7. All the supported EN-DC combinations are verified conducted power, only the EN-DC combination with highest power are shown in the report.
8. The EN-DC mode combination could be referred to the product spec.

1.5 Modification of EUT

No modifications are made to the EUT during all test items.

1.6 Maximum EIRP Power and Emission Designator

5G NR n77 UL MIMO		PI/2 BPSK / QPSK		16QAM/64QAM/256QAM	
BW (MHz)	Frequency Range (MHz)	Maximum EIRP(W)	Emission Designator (99%OBW)	Maximum EIRP(W)	Emission Designator (99%OBW)
10	3455.01 ~ 3544.98	0.6975	9M35G7D	0.6368	9M31W7D
15	3457.50 ~ 3542.49	0.6879	14M1G7D	0.6390	14M2W7D
20	3460.02 ~ 3540.00	0.6904	18M9G7D	0.6468	19M1W7D
25	3462.51 ~ 3537.48	0.7039	23M7G7D	0.6564	24M0W7D
30	3465.00 ~ 3534.99	0.6943	28M8G7D	0.6450	28M8W7D
40	3470.01 ~ 3529.98	0.6999	38M8G7D	0.6587	38M0W7D
50	3475.02 ~ 3525.00	0.7048	48M1G7D	0.6465	48M7W7D
60	3480.00 ~ 3519.99	0.7074	57M9G7D	0.6473	57M9W7D
70	3485.01 ~ 3514.98	0.7146	67M6G7D	0.6578	67M6W7D
80	3490.02 ~ 3510.00	0.7212	77M6G7D	0.6740	77M6W7D
90	3495.00 ~ 3504.99	0.7254	87M6G7D	0.6738	87M8W7D
100	3500.01	0.7262	97M7G7D	0.6785	97M5W7D



5G NR n78 UL MIMO		PI/2 BPSK / QPSK		16QAM/64QAM/256QAM	
BW (MHz)	Frequency Range (MHz)	Maximum EIRP(W)	Emission Designator (99%OBW)	Maximum EIRP(W)	Emission Designator (99%OBW)
10	3455.01 ~ 3544.98	0.2178	9M35G7D	0.1987	9M31W7D
15	3457.50 ~ 3542.49	0.2139	14M1G7D	0.1968	14M2W7D
20	3460.02 ~ 3540.00	0.2155	18M9G7D	0.1928	19M1W7D
25	3462.51 ~ 3537.48	0.2197	23M7G7D	0.1988	24M0W7D
30	3465.00 ~ 3534.99	0.2187	28M8G7D	0.1979	28M8W7D
40	3470.01 ~ 3529.98	0.2158	38M8G7D	0.1975	38M0W7D
50	3475.02 ~ 3525.00	0.2153	48M1G7D	0.1956	48M7W7D
60	3480.00 ~ 3519.99	0.2107	57M9G7D	0.1928	57M9W7D
70	3485.01 ~ 3514.98	0.2220	67M6G7D	0.2027	67M6W7D
80	3490.02 ~ 3510.00	0.2196	77M6G7D	0.1998	77M6W7D
90	3495.00 ~ 3504.99	0.2230	87M6G7D	0.2020	87M8W7D
100	3500.01	0.2236	97M7G7D	0.2036	97M5W7D

Note:

- 5G NR Band n77 overlaps the entire frequency range of Band n78, and n77 power > n78 power, therefore the conducted test results of n78 provided in this report cover n77.
- SCS 15KHz & 30KHz, SISO & MIMO mode, and all modulations have been tested, and only the worst test results are shown here.

1.7 Testing Site

Sporton International Inc. (Kunshan) is accredited to ISO/IEC 17025:2017 by American Association for Laboratory Accreditation with Certificate Number 5145.02.

Test Firm	Sporton International Inc. (Kunshan)		
Test Site Location	No. 1098, Pengxi North Road, Kunshan Economic Development Zone Jiangsu Province 215300 People's Republic of China TEL : +86-512-57900158		
Test Site No.	Sporton Site No.	FCC Designation No.	FCC Test Firm Registration No.
	03CH04-KS TH01-KS	CN1257	314309

1.8 Test Software

Item	Site	Manufacture	Name	Version
1.	TH01-KS	SPORTON	FCC_5GNR_China_2 01027	1.0
2.	03CH04-KS	AUDIX	E3	210616

1.9 Applied Standards

According to the specifications of the manufacturer, the EUT must comply with the requirements of the following standards:

- ♦ 47 CFR Part 2, Part 27 Subpart Q
- ♦ ANSI C63.26-2015
- ♦ FCC KDB 971168 Power Meas License Digital Systems D01 v03r01
- ♦ FCC KDB 412172 D01 Determining ERP and EIRP v01r01

Remark: All test items were verified and recorded according to the standards and without any deviation during the test.

1.10 Specification of Accessory

Specification of Accessory				
Battery 1	Brand Name	Motorola	Model Name	QR11
Battery 2	Brand Name	Motorola	Model Name	QR31
USB Cable 1	Brand Name	Motorola(CABLETECH)	Model Name	SC18E05246
USB Cable 2	Brand Name	Motorola(SAIBAO)	Model Name	SC18D86732

2 Test Configuration of Equipment Under Test

2.1 Test Mode



Antenna port conducted and radiated test items listed below are performed according to KDB 971168 D01 Power Meas. License Digital Systems v03r01 with maximum output power.

Radiated measurements are performed by rotating the EUT in three different orthogonal test planes to find the maximum emission. (Y Plane).

The EUT is a folding phone, pretest the open status and closed status, only the worst status perform final test and record in the report.

For the accessories, pretest standalone mode / Earphone mode / Adapter mode / Wireless charging mode, only the worst status perform final test and record in the report.

The device is investigated from 30MHz to 10 times of fundamental signal for radiated spurious emission test under different RB size/offset and modulations in exploratory test. Subsequently, only the worst case emissions are reported.

	X Plane	Y Plane	Z Plane
Orthogonal Planes of EUT			



Test Cases	Band	Bandwidth (MHz)	Modulation	RB #	Test Channel
		eg. 5M, 10M, 15M, 20M	eg. PI/2 BPSK, QPSK, 16QAM, 64QAM, 256QAM	1RB, Partial RB, Full RB	L/M/H
Max. Output Power	5G n77	10M, 15M, 20M, 25M, 30M, 40M, 50M, 60M, 70M, 80M, 90M ,100M	All Modulations	1RB, Full RB	L, M, H
	5G n78	10M, 15M, 20M, 25M, 30M, 40M, 50M, 60M, 70M, 80M, 90M ,100M	All Modulations	1RB, Full RB	L, M, H
Peak-to-Average Ratio	5G n77	100M	PI/2 BPSK, QPSK	1RB, Full RB	M
E.I.R.P	5G n77	10M, 15M, 20M, 25M, 30M, 40M, 50M, 60M, 70M, 80M, 90M ,100M	All Modulations	1RB, Full RB	L, M, H
	5G n78	10M, 15M, 20M, 25M, 30M, 40M, 50M, 60M, 70M, 80M, 90M ,100M	All Modulations	1RB, Full RB	L, M, H
26dB and 99% Bandwidth	5G n77	60M, 70M, 80M, 90M ,100M	QPSK, 16QAM, 64QAM, 256QAM	Full RB	M
Conducted Band Edge	5G n77	60M, 80M, 100M	PI/2 BPSK, QPSK	1RB, Full RB	L, H
Conducted Spurious Emission	5G n77	60M, 80M, 100M	PI/2 BPSK, QPSK	1RB	L, M, H
Frequency Stability	5G n77	100M	QPSK	Full RB	M
Radiated Spurious Emission	5G n77	Worst case from maximum power			M

Note:

- The device is investigated from 30MHz to 10 times of fundamental signal for radiated spurious emission test under different RB size/offset and modulations in exploratory test. Subsequently, only the worst case emissions are reported.
- Frequency Stability: Normal Voltage = 3.88V ; Low Voltage =3.4V.; High Voltage =4.48V.

2.2 Connection Diagram of Test System

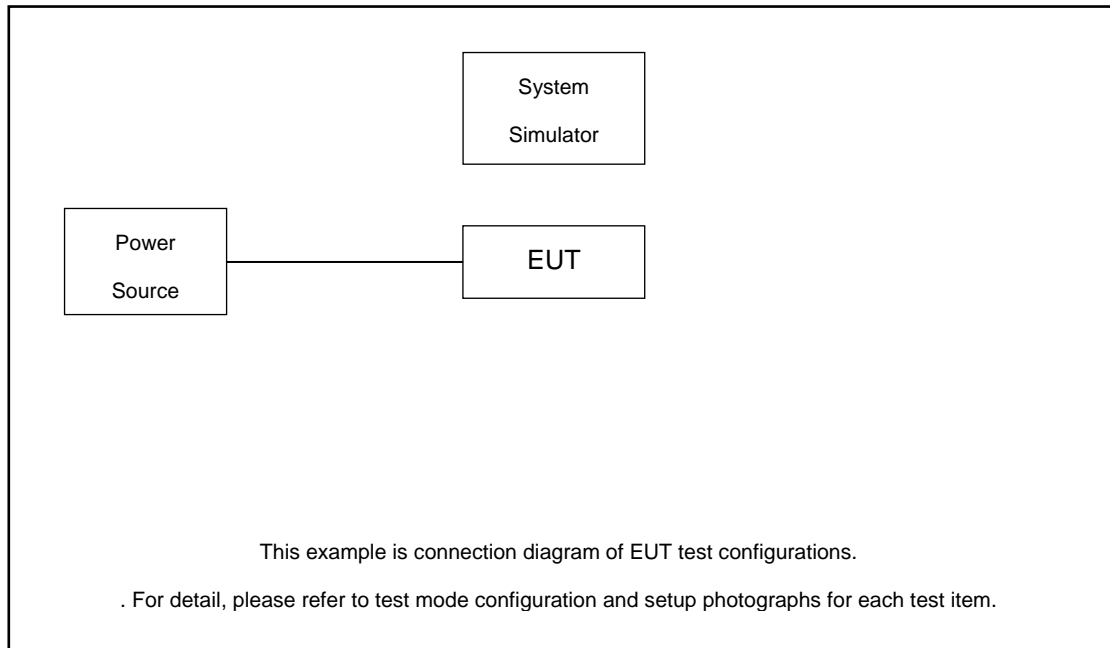

2.3 Support Unit used in test configuration and system

Item	Equipment	Trade Name	Model No.	FCC ID	Data Cable	Power Cord
1.	Power Supply	GWINSTEK	PSS-2002	N/A	N/A	Unshielded, 1.8 m
2.	LTE Base Station	Anritsu	MT8820C	N/A	N/A	Unshielded, 1.8 m
3.	NR Base Station	Anritsu	MT8000A	N/A	N/A	Unshielded, 1.8 m

2.4 Measurement Results Explanation Example

For all conducted test items:

The offset level is set in the spectrum analyzer to compensate the RF cable loss and attenuator factor between EUT conducted output port and spectrum analyzer. With the offset compensation, the spectrum analyzer reading level is exactly the EUT RF output level.

The spectrum analyzer offset is derived from RF cable loss and attenuator factor.

$$\text{Offset} = \text{RF cable loss} + \text{attenuator factor}.$$

Following shows an offset computation example with cable loss 6.5 dB and 20dB attenuator.

Example :

$$\begin{aligned} \text{Offset(dB)} &= \text{RF cable loss(dB)} + \text{attenuator factor(dB)}. \\ &= 6.5 + 20 = 26.5 \text{ (dB)} \end{aligned}$$



2.5 Frequency List of Low/Middle/High Channels

5G n77/n78 Channel and Frequency List for SCS 15kHz				
BW [MHz]	Channel/Frequency(MHz)	Lowest	Middle	Highest
50	Channel	631667	633334	635000
	Frequency	3475.005	3500.01	3525
40	Channel	631334	633334	635333
	Frequency	3470.01	3500.01	3529.995
30	Channel	631000	633334	635666
	Frequency	3465	3500.01	3534.99
25	Channel	630834	633334	635833
	Frequency	3462.51	3500.01	3537.495
20	Channel	630667	633334	636000
	Frequency	3460.005	3500.01	3540
15	Channel	630500	633334	636166
	Frequency	3457.5	3500.01	3542.49
10	Channel	630334	633334	636333
	Frequency	3455.01	3500.01	3544.995



5G n77/n78 Channel and Frequency List for SCS 30kHz				
BW [MHz]	Channel/Frequency(MHz)	Lowest	Middle	Highest
100	Channel	-	633334	-
	Frequency	-	3500.01	-
90	Channel	633000	633334	633666
	Frequency	3495	3500.01	3504.99
80	Channel	632668	633334	634000
	Frequency	3490.02	3500.01	3510
70	Channel	632334	633334	634332
	Frequency	3485.01	3500.01	3514.98
60	Channel	632000	633334	634666
	Frequency	3480	3500.01	3519.99
50	Channel	631668	633334	635000
	Frequency	3475.02	3500.01	3525
40	Channel	631334	633334	635332
	Frequency	3470.01	3500.01	3529.98
30	Channel	631000	633334	635666
	Frequency	3465	3500.01	3534.99
25	Channel	630834	633334	635832
	Frequency	3462.51	3500.01	3537.48
20	Channel	630668	633334	636000
	Frequency	3460.02	3500.01	3540
15	Channel	630500	633334	636166
	Frequency	3457.5	3500.01	3542.49
10	Channel	630334	633334	636332
	Frequency	3455.01	3500.01	3544.98

3 Conducted Test Items

3.1 Measuring Instruments

See list of measuring instruments of this test report.

3.2 Test Setup

3.2.1 Conducted Output Power

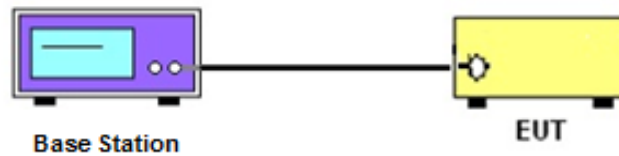

3.2.2 Peak-to-Average Ratio, Occupied / 26dB Bandwidth, Band-Edge and Conducted Spurious Emission

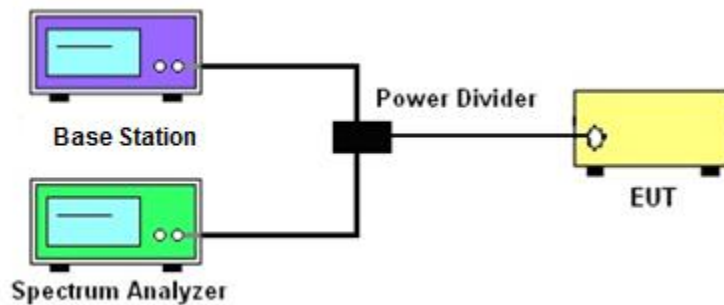

3.2.3 Frequency Stability

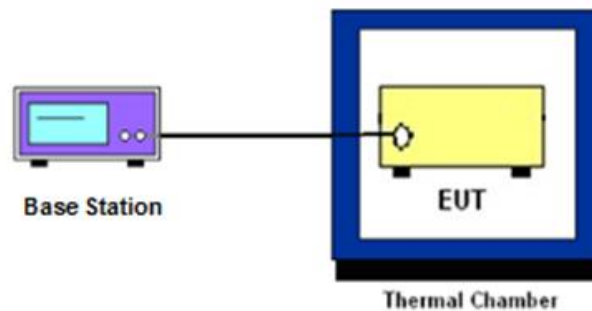

3.3 Test Result of Conducted Test

Please refer to Appendix A.



3.4 Conducted Output Power Measurement

3.4.1 Description of the Conducted Output Power Measurement

A base station simulator was used to establish communication with the EUT. Its parameters were set to transmit the maximum power on the EUT. The measured power in the radio frequency on the transmitter output terminals shall be reported.

3.4.2 Test Procedures

1. The testing follows ANSI C63.26 Section 5.2
2. The transmitter output port was connected to the system simulator.
3. Set EUT at maximum power through the system simulator.
4. Select lowest, middle, and highest channels for each band and different modulation.
5. Measure and record the power level from the system simulator.

3.5 Peak-to-Average Ratio

3.5.1 Description of the PAR Measurement

Power Complementary Cumulative Distribution Function (CCDF) curves provide a means for characterizing the power peaks of a digitally modulated signal on a statistical basis. A CCDF curve depicts the probability of the peak signal amplitude exceeding the average power level. Most contemporary measurement instrumentation include the capability to produce CCDF curves for an input signal provided that the instrument's resolution bandwidth can be set wide enough to accommodate the entire input signal bandwidth. In measuring transmissions in this band using an average power technique, the peak-to-average ratio (PAR) of the transmission may not exceed 13 dB.

3.5.2 Test Procedures

1. The testing follows ANSI C63.26 Section 5.2.3.4 (CCDF).
2. The EUT was connected to spectrum and system simulator via a power divider.
3. Set the CCDF (Complementary Cumulative Distribution Function) option in spectrum analyzer.
4. The highest RF powers were measured and recorded the maximum PAPR level associated with a probability of 0.1 %.
5. Record the deviation as Peak to Average Ratio.

3.6 EIRP

3.6.1 Description of EIRP Limit

§ 27.50 (k)(3)

Mobile devices are limited to 1Watt (30 dBm) EIRP. Mobile devices operating in these bands must employ a means for limiting power to the minimum necessary for successful communications

3.6.2 Test Procedures

1. According to KDB 412172 D01 Power Approach,
2. $EIRP = P_T + G_T - L_C$, $ERP = EIRP - 2.15$, where
 P_T = transmitter output power in dBm
 G_T = gain of the transmitting antenna in dBi
 L_C = signal attenuation in the connecting cable between the transmitter and antenna in dB

3.7 Occupied Bandwidth

3.7.1 Description of Occupied Bandwidth Measurement

The occupied bandwidth is the width of a frequency band such that, below the lower and above the upper frequency limits, the mean powers emitted are each equal to a specified percentage 0.5% of the total mean transmitted power.

The 26 dB emission bandwidth is defined as the frequency range between two points, one above and one below the carrier frequency, at which the spectral density of the emission is attenuated 26 dB below the maximum in-band spectral density of the modulated signal. Spectral density (power per unit bandwidth) is to be measured with a detector of resolution bandwidth equal to approximately 1.0% of the emission bandwidth.

3.7.2 Test Procedures

1. The testing follows ANSI C63.26 Section 5.4
2. The EUT was connected to spectrum analyzer and system simulator via a power divider.
3. The spectrum analyzer center frequency is set to the nominal EUT channel center frequency. The span range for the spectrum analyzer shall be between two and five times the anticipated OBW.
4. The nominal resolution bandwidth (RBW) shall be in the range of 1 to 5 % of the anticipated OBW, and the VBW shall be at least 3 times the RBW.
5. Set the detection mode to peak, and the trace mode to max hold.
6. Determine the reference value: Set the EUT to transmit a modulated signal. Allow the trace to stabilize. Set the spectrum analyzer marker to the highest level of the displayed trace.
(this is the reference value)
7. Determine the “-26 dB down amplitude” as equal to (Reference Value – X).
8. Place two markers, one at the lowest and the other at the highest frequency of the envelope of the spectral display such that each marker is at or slightly below the “-X dB down amplitude” determined in step 6. If a marker is below this “-X dB down amplitude” value it shall be placed as close as possible to this value. The OBW is the positive frequency difference between the two markers.
9. Use the 99 % power bandwidth function of the spectrum analyzer and report the measured bandwidth.

3.8 Conducted Band Edge Measurement

3.8.1 Description of Conducted Band Edge Measurement

§ 27.53 (n)(2)

For mobile operations in the 3450-3550 MHz band, the conducted power of any emission outside the licensee's authorized bandwidth shall not exceed -13 dBm/MHz.

Compliance with this paragraph is based on the use of measurement instrumentation employing a resolution bandwidth of 1 megahertz or greater. However, in the 1 megahertz bands immediately outside and adjacent to the licensee's frequency block, a resolution bandwidth of at least one percent of the emission bandwidth of the fundamental emission of the transmitter may be employed, but limited to a maximum of 200 kHz. In the bands between 1 and 5 MHz removed from the licensee's frequency block, the minimum resolution bandwidth for the measurement shall be 500 kHz.

3.8.2 Test Procedures

1. The testing follows ANSI C63.26 section 5.7
2. The EUT was connected to spectrum analyzer and system simulator via a power divider.
3. The band edges of low and high channels for the highest RF powers were measured.
4. Set RBW $\geq 1\%$ EBW but limited to a maximum of 200 kHz in the 1MHz band immediately outside and adjacent to the band edge.
5. Beyond the 1 MHz and 5 MHz removed from the band edge, set RBW ≥ 500 KHz.
6. Beyond the 5 MHz removed from the band edge, set RBW = 1MHz.
7. Set spectrum analyzer with RMS detector.
8. The RF fundamental frequency should be excluded against the limit line in the operating frequency band.
9. Checked that all the results comply with the emission limit line.

3.9 Conducted Spurious Emission Measurement

3.9.1 Description of Conducted Spurious Emission Measurement

The power of any emission outside of the authorized operating frequency ranges shall not exceed -13 dBm/MHz.

It is measured by means of a calibrated spectrum analyzer and scanned from 9 kHz up to a frequency including its 10th harmonic.

3.9.2 Test Procedures

1. The testing follows ANSI C63.26 section 5.7
2. The EUT was connected to spectrum analyzer and system simulator via a power divider.
3. The RF output of EUT was connected to the spectrum analyzer by RF cable and attenuator.
The path loss was compensated to the results for each measurement.
4. The middle channel for the highest RF power within the transmitting frequency was measured.
5. The conducted spurious emission for the whole frequency range was taken.
6. Make the measurement with the spectrum analyzer's RBW = 1MHz, VBW = 3MHz.
7. Set spectrum analyzer with RMS detector.
8. Taking the record of maximum spurious emission.
9. The RF fundamental frequency should be excluded against the limit line in the operating frequency band.
10. Checked that all the results comply with the emission limit line.

3.10 Frequency Stability Measurement

3.10.1 Description of Frequency Stability Measurement

The frequency stability shall be measured by variation of ambient temperature and variation of primary supply voltage to ensure that the fundamental emission stays within the authorized frequency block.

3.10.2 Test Procedures for Temperature Variation

1. The testing follows ANSI C63.26 section 5.6.4
2. The EUT was set up in the thermal chamber and connected with the system simulator.
3. With power OFF, the temperature was decreased to -30°C and the EUT was stabilized before testing. Power was applied and the maximum change in frequency was recorded within one minute.
4. With power OFF, the temperature was raised in 10°C step up to 50°C . The EUT was stabilized at each step for at least half an hour. Power was applied and the maximum frequency change was recorded within one minute.

3.10.3 Test Procedures for Voltage Variation

1. The testing follows ANSI C63.26 section 5.6.5.
2. The EUT was placed in a temperature chamber at $20\pm 5^{\circ}\text{C}$ and connected with the system simulator.
3. The power supply voltage to the EUT was varied from 85% to 115% of the nominal value for other than hand carried battery equipment.
4. For hand carried, battery powered equipment, reduce the primary ac or dc supply voltage to the battery operating end point, which shall be specified by the manufacturer.
5. The variation in frequency was measured for the worst case.

4 Radiated Test Items

4.1 Measuring Instruments

See list of measuring instruments of this test report.

4.2 Test Setup

4.2.1 For radiated test below 30MHz

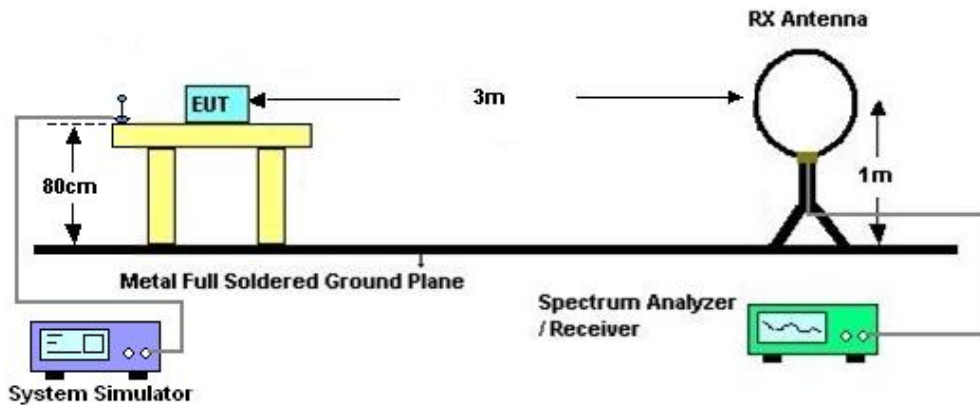

4.2.2 For radiated test from 30MHz to 1GHz

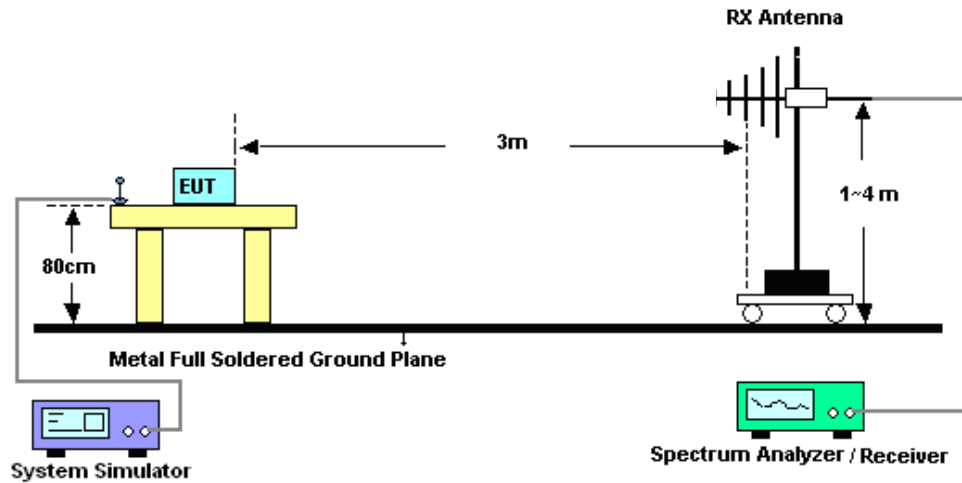

4.2.3 For radiated test above 1GHz

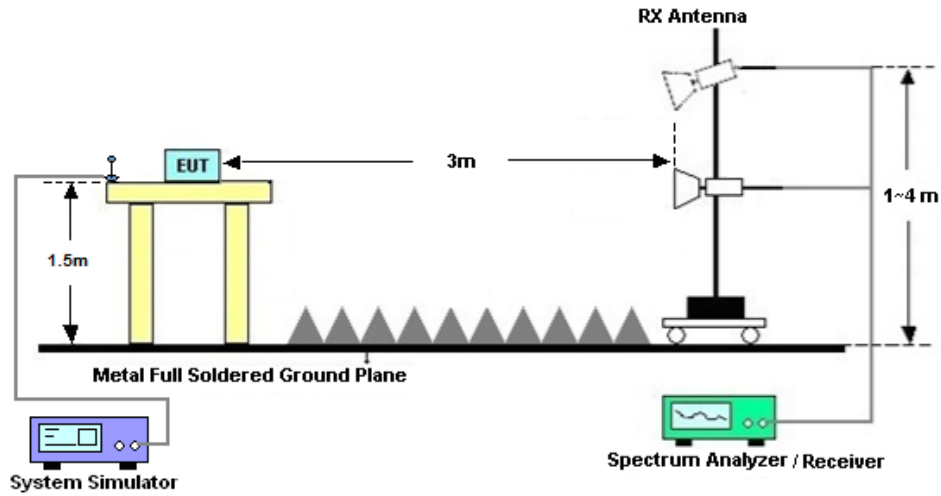

4.3 Test Result of Radiated Test

The low frequency, which started from 9 kHz to 30MHz, was pre-scanned and the result which was 20dB lower than the limit line was not reported.

Please refer to Appendix B.

4.4 Radiated Spurious Emission Measurement

4.4.1 Description of Radiated Spurious Emission

The radiated spurious emission was measured by substitution method according to ANSI/TIA-603-E. The power of any emission outside of the authorized operating frequency ranges shall not exceed -13 dBm/MHz.

The spectrum is scanned from 30 MHz up to a frequency including its 10th harmonic.

4.4.2 Test Procedures

1. The testing follows ANSI C63.26 Section 5.5
2. The EUT was placed on a turntable with 0.8 meter height for frequency below 1GHz and 1.5 meter height for frequency above 1GHz respectively above ground.
3. The EUT was set 3 meters from the receiving antenna mounted on the antenna tower.
4. The table was rotated 360 degrees to determine the position of the highest spurious emission.
5. The height of the receiving antenna is varied between 1m to 4m to search the maximum spurious emission for both horizontal and vertical polarizations.
6. During the measurement, the system simulator parameters were set to force the EUT transmitting at maximum output power.
7. Make the measurement with the spectrum analyzer's RBW = 1MHz, VBW = 3MHz, taking the record of maximum spurious emission.
8. A horn antenna was substituted in place of the EUT and was driven by a signal generator.
9. Tune the output power of signal generator to the same emission level with EUT maximum spurious emission.
$$\text{EIRP (dBm)} = \text{S.G. Power} - \text{Tx Cable Loss} + \text{Tx Antenna Gain}$$
$$\text{ERP (dBm)} = \text{EIRP} - 2.15$$
10. The RF fundamental frequency should be excluded against the limit line in the operating frequency band.



5 List of Measuring Equipment

Instrument	Manufacturer	Model No.	Serial No.	Characteristics	Calibration Date	Test Date	Due Date	Remark
Spectrum Analyzer	R&S	FSV40	101040	10Hz~40GHz	Oct. 11, 2023	Mar. 15, 2024~ Mar. 28, 2024	Oct. 10, 2024	Conducted (TH01-KS)
Power divider	STI	STI08-0055	-	0.5~40GHz	NCR	Mar. 15, 2024~ Mar. 28, 2024	NCR	Conducted (TH01-KS)
Temperature & humidity chamber	Hongzhan	LP-150U	H2014011440	-40~+150°C 20%~95%RH	Jul. 06, 2023	Mar. 15, 2024~ Mar. 28, 2024	Jul. 05, 2024	Conducted (TH01-KS)
EXA Spectrum Analyzer	Keysight	N9010B	MY57471079	10Hz~44G,MAX 30dB	Oct. 10, 2023	Mar. 28, 2024	Oct. 09, 2024	Radiation (03CH04-KS)
Loop Antenna	R&S	HFH2-Z2	100354	9kHz~30MHz	Jun. 28, 2022	Mar. 28, 2024	Jun. 27, 2024	Radiation (03CH04-SZ)
Bilog Antenna	TeseQ	CBL6111D	49922	30MHz~1GHz	Apr. 09, 2023	Mar. 28, 2024	Apr. 08, 2024	Radiation (03CH04-KS)
Double Ridge Horn Antenna	ETS-Lindgren	3117	00251694	1GHz~18GHz	Jul. 12, 2023	Mar. 28, 2024	Jul. 11, 2024	Radiation (03CH04-KS)
SHF-EHF Horn	Com-power	AH-840	101070	18GHz~40GHz	Jan. 05, 2024	Mar. 28, 2024	Jan. 04, 2025	Radiation (03CH04-KS)
Amplifier	SONOMA	310N	380827	9KHz-1GHz	Jul. 06, 2023	Mar. 28, 2024	Jul. 05, 2024	Radiation (03CH04-KS)
Amplifier	MITEQ	EM18G40G GA	060728	18~40GHz	Jan. 05, 2024	Mar. 28, 2024	Jan. 04, 2025	Radiation (03CH04-KS)
high gain Amplifier	EM	EM01G18G A	060840	1Ghz-18Ghz	Oct. 10, 2023	Mar. 28, 2024	Oct. 09, 2024	Radiation (03CH04-KS)
Amplifier	Agilent	8449B	3008A02370	1Ghz-18Ghz	Oct. 10, 2023	Mar. 28, 2024	Oct. 09, 2024	Radiation (03CH04-KS)
AC Power Source	Chroma	61601	F104090004	N/A	NCR	Mar. 28, 2024	NCR	Radiation (03CH04-KS)
Turn Table	ChamPro	EM 1000-T	060762-T	0~360 degree	NCR	Mar. 28, 2024	NCR	Radiation (03CH04-KS)
Antenna Mast	ChamPro	EM 1000-A	060762-A	1 m~4 m	NCR	Mar. 28, 2024	NCR	Radiation (03CH04-KS)

NCR: No Calibration Required

6 Measurement Uncertainty

The measurement uncertainties shown below were calculated in accordance with the requirements of ANSI 63.26-2015. All the measurement uncertainty value were shown with a coverage K=2 to indicate 95% level of confidence. The measurement data show herein meets or exceeds the CISPR measurement uncertainty values specified in CISPR 16-4-2 and can be compared directly to specified limit to determine compliance.

Uncertainty of Conducted Measurement

Conducted Spurious Emission & Bandedge	±2.26 dB
Occupied Channel Bandwidth	±0.1%
Conducted Power	±0.46 dB
Peak to Average Ratio	±0.46 dB
Frequency Stability	±0.4 Hz

Uncertainty of Radiated Emission Measurement (30 MHz ~ 1000 MHz)

Measuring Uncertainty for a Level of Confidence of 95% (U = 2Uc(y))	3.82 dB
--	----------------

Uncertainty of Radiated Emission Measurement (1 GHz ~ 18 GHz)

Measuring Uncertainty for a Level of Confidence of 95% (U = 2Uc(y))	3.56 dB
--	----------------

Uncertainty of Radiated Emission Measurement (18 GHz ~ 40 GHz)

Measuring Uncertainty for a Level of Confidence of 95% (U = 2Uc(y))	5.26 dB
--	----------------

----- THE END -----



Appendix A. Test Results of Conducted Test

Test Engineer :	Smile Wang	Temperature :	22~23°C
		Relative Humidity :	40~42%

FR1 N77-SCS 15K(SISO_ANT4)

Transmitter Conducted Output Power And EIRP,(G_T - L_C)=-1.89dB

NR Band	SCS	Band Width	Arfcn	Freq (MHz)	Modulation	RB	Conducted Power(dBm)	EIRP(dBm)	EIRP(W)
77	15	10	630334	3455.01	DFT-s-OFDM PI/2 BPSK	1@1	26.23	24.34	0.2716
77	15	10	630334	3455.01	DFT-s-OFDM QPSK	1@1	26.4	24.51	0.2825
77	15	10	630334	3455.01	DFT-s-OFDM 16 QAM	1@1	24.66	22.77	0.1892
77	15	10	633334	3500.01	DFT-s-OFDM PI/2 BPSK	1@1	25.99	24.1	0.2570
77	15	10	633334	3500.01	DFT-s-OFDM QPSK	1@1	25.94	24.05	0.2541
77	15	10	633334	3500.01	DFT-s-OFDM 16 QAM	1@1	24.83	22.94	0.1968
77	15	10	636333	3544.995	DFT-s-OFDM PI/2 BPSK	1@1	25.48	23.59	0.2286
77	15	10	636333	3544.995	DFT-s-OFDM QPSK	1@1	25.59	23.7	0.2344
77	15	10	636333	3544.995	DFT-s-OFDM 16 QAM	1@1	24.57	22.68	0.1854
77	15	15	630500	3457.5	DFT-s-OFDM PI/2 BPSK	1@1	26.22	24.33	0.2710
77	15	15	630500	3457.5	DFT-s-OFDM QPSK	1@1	26.41	24.52	0.2831
77	15	15	630500	3457.5	DFT-s-OFDM 16 QAM	1@1	25.35	23.46	0.2218
77	15	15	633334	3500.01	DFT-s-OFDM PI/2 BPSK	1@1	25.37	23.48	0.2228
77	15	15	633334	3500.01	DFT-s-OFDM QPSK	1@1	25.33	23.44	0.2208
77	15	15	633334	3500.01	DFT-s-OFDM 16 QAM	1@1	24.26	22.37	0.1726
77	15	15	636166	3542.49	DFT-s-OFDM PI/2 BPSK	1@1	26.01	24.12	0.2582
77	15	15	636166	3542.49	DFT-s-OFDM QPSK	1@1	26.17	24.28	0.2679
77	15	15	636166	3542.49	DFT-s-OFDM 16 QAM	1@1	25.22	23.33	0.2153
77	15	20	630667	3549.99	DFT-s-OFDM PI/2 BPSK	1@1	25.03	23.14	0.2061
77	15	20	630667	3460.005	DFT-s-OFDM QPSK	1@1	25.59	23.7	0.2344
77	15	20	630667	3460.005	DFT-s-OFDM 16 QAM	1@1	25.28	23.39	0.2183
77	15	20	633334	3500.01	DFT-s-OFDM PI/2 BPSK	1@1	25.29	23.4	0.2188
77	15	20	633334	3500.01	DFT-s-OFDM QPSK	1@1	26.03	24.14	0.2594
77	15	20	633334	3500.01	DFT-s-OFDM 16 QAM	1@1	24.37	22.48	0.1770
77	15	20	636000	3540	DFT-s-OFDM PI/2 BPSK	1@1	25.94	24.05	0.2541
77	15	20	636000	3540	DFT-s-OFDM QPSK	1@1	26.11	24.22	0.2642
77	15	20	636000	3540	DFT-s-OFDM 16 QAM	1@1	25.05	23.16	0.2070
77	15	25	630834	3462.51	DFT-s-OFDM PI/2 BPSK	1@1	26.14	24.25	0.2661
77	15	25	630834	3462.51	DFT-s-OFDM QPSK	1@1	26.28	24.39	0.2748
77	15	25	630834	3462.51	DFT-s-OFDM 16 QAM	1@1	25.35	23.46	0.2218
77	15	25	633334	3500.01	DFT-s-OFDM PI/2 BPSK	1@1	25.92	24.03	0.2529
77	15	25	633334	3500.01	DFT-s-OFDM QPSK	1@1	26.06	24.17	0.2612
77	15	25	633334	3500.01	DFT-s-OFDM 16 QAM	1@1	25.03	23.14	0.2061
77	15	25	635833	3537.495	DFT-s-OFDM PI/2 BPSK	1@1	25.39	23.5	0.2239
77	15	25	635833	3537.495	DFT-s-OFDM QPSK	1@1	25.51	23.62	0.2301
77	15	25	635833	3537.495	DFT-s-OFDM 16 QAM	1@1	25.1	23.21	0.2094
77	15	30	631000	3465	DFT-s-OFDM PI/2 BPSK	1@1	26.14	24.25	0.2661
77	15	30	631000	3465	DFT-s-OFDM QPSK	1@1	26.32	24.43	0.2773
77	15	30	631000	3465	DFT-s-OFDM 16 QAM	1@1	25.32	23.43	0.2203

77	15	30	633334	3500.01	DFT-s-OFDM PI/2 BPSK	1@1	25.93	24.04	0.2535
77	15	30	633334	3500.01	DFT-s-OFDM QPSK	1@1	25.31	23.42	0.2198
77	15	30	633334	3500.01	DFT-s-OFDM 16 QAM	1@1	25.29	23.4	0.2188
77	15	30	635666	3534.99	DFT-s-OFDM PI/2 BPSK	1@1	25.41	23.52	0.2249
77	15	30	635666	3534.99	DFT-s-OFDM QPSK	1@1	26.12	24.23	0.2649
77	15	30	635666	3534.99	DFT-s-OFDM 16 QAM	1@1	24.58	22.69	0.1858
77	15	40	631334	3470.01	DFT-s-OFDM PI/2 BPSK	1@1	26.11	24.22	0.2642
77	15	40	631334	3470.01	DFT-s-OFDM QPSK	1@1	26.22	24.33	0.2710
77	15	40	631334	3470.01	DFT-s-OFDM 16 QAM	1@1	25.23	23.34	0.2158
77	15	40	633334	3500.01	DFT-s-OFDM PI/2 BPSK	1@1	25.99	24.1	0.2570
77	15	40	633334	3500.01	DFT-s-OFDM QPSK	1@1	25.6	23.71	0.2350
77	15	40	633334	3500.01	DFT-s-OFDM 16 QAM	1@1	25.08	23.19	0.2084
77	15	40	635333	3529.995	DFT-s-OFDM PI/2 BPSK	1@1	25.38	23.49	0.2234
77	15	40	635333	3529.995	DFT-s-OFDM QPSK	1@1	26.02	24.13	0.2588
77	15	40	635333	3529.995	DFT-s-OFDM 16 QAM	1@1	25.16	23.27	0.2123
77	15	50	631667	3475.005	DFT-s-OFDM PI/2 BPSK	135@67	26.13	24.24	0.2655
77	15	50	631667	3475.005	DFT-s-OFDM PI/2 BPSK	1@1	26.24	24.35	0.2723
77	15	50	631667	3475.005	DFT-s-OFDM PI/2 BPSK	1@268	25.87	23.98	0.2500
77	15	50	631667	3475.005	DFT-s-OFDM QPSK	135@67	26.15	24.26	0.2667
77	15	50	631667	3475.005	DFT-s-OFDM QPSK	1@1	26.41	24.52	0.2831
77	15	50	631667	3475.005	DFT-s-OFDM QPSK	1@268	25.8	23.91	0.2460
77	15	50	631667	3475.005	DFT-s-OFDM 16 QAM	135@67	25.18	23.29	0.2133
77	15	50	631667	3475.005	DFT-s-OFDM 16 QAM	1@1	25.32	23.43	0.2203
77	15	50	631667	3475.005	DFT-s-OFDM 16 QAM	1@268	25.04	23.15	0.2065
77	15	50	631667	3475.005	DFT-s-OFDM 64 QAM	135@67	23.72	21.83	0.1524
77	15	50	631667	3475.005	DFT-s-OFDM 64 QAM	1@1	23.63	21.74	0.1493
77	15	50	631667	3475.005	DFT-s-OFDM 64 QAM	1@268	23.29	21.4	0.1380
77	15	50	631667	3475.005	DFT-s-OFDM 256 QAM	135@67	25.02	23.13	0.2056
77	15	50	631667	3475.005	DFT-s-OFDM 256 QAM	1@1	24.95	23.06	0.2023
77	15	50	631667	3475.005	DFT-s-OFDM 256 QAM	1@268	21.47	19.58	0.0908
77	15	50	631667	3475.005	CP-OFDM QPSK	135@67	26.02	24.13	0.2588
77	15	50	631667	3475.005	CP-OFDM QPSK	1@1	24.7	22.81	0.1910
77	15	50	631667	3475.005	CP-OFDM QPSK	1@268	24.44	22.55	0.1799
77	15	50	633334	3500.01	DFT-s-OFDM PI/2 BPSK	135@67	26.08	24.19	0.2624
77	15	50	633334	3500.01	DFT-s-OFDM PI/2 BPSK	1@1	26.03	24.14	0.2594
77	15	50	633334	3500.01	DFT-s-OFDM PI/2 BPSK	1@268	25.82	23.93	0.2472
77	15	50	633334	3500.01	DFT-s-OFDM QPSK	135@67	26.03	24.14	0.2594
77	15	50	633334	3500.01	DFT-s-OFDM QPSK	1@1	26.26	24.37	0.2735
77	15	50	633334	3500.01	DFT-s-OFDM QPSK	1@268	25.82	23.93	0.2472
77	15	50	633334	3500.01	DFT-s-OFDM 16 QAM	135@67	24.82	22.93	0.1963
77	15	50	633334	3500.01	DFT-s-OFDM 16 QAM	1@1	25.28	23.39	0.2183
77	15	50	633334	3500.01	DFT-s-OFDM 16 QAM	1@268	25.12	23.23	0.2104
77	15	50	633334	3500.01	DFT-s-OFDM 64 QAM	135@67	24.56	22.67	0.1849
77	15	50	633334	3500.01	DFT-s-OFDM 64 QAM	1@1	23.6	21.71	0.1483
77	15	50	633334	3500.01	DFT-s-OFDM 64 QAM	1@268	23.29	21.4	0.1380
77	15	50	633334	3500.01	DFT-s-OFDM 256 QAM	135@67	21.54	19.65	0.0923
77	15	50	633334	3500.01	DFT-s-OFDM 256 QAM	1@1	21.66	19.77	0.0948

77	15	50	633334	3500.01	DFT-s-OFDM 256 QAM	1@268	21.48	19.59	0.0910
77	15	50	633334	3500.01	CP-OFDM QPSK	135@67	24.51	22.62	0.1828
77	15	50	633334	3500.01	CP-OFDM QPSK	1@1	24.59	22.7	0.1862
77	15	50	633334	3500.01	CP-OFDM QPSK	1@268	24.36	22.47	0.1766
77	15	50	635000	3525	DFT-s-OFDM PI/2 BPSK	135@67	25.53	23.64	0.2312
77	15	50	635000	3525	DFT-s-OFDM PI/2 BPSK	1@1	25.51	23.62	0.2301
77	15	50	635000	3525	DFT-s-OFDM PI/2 BPSK	1@268	25.94	24.05	0.2541
77	15	50	635000	3525	DFT-s-OFDM QPSK	135@67	25.49	23.6	0.2291
77	15	50	635000	3525	DFT-s-OFDM QPSK	1@1	26.19	24.3	0.2692
77	15	50	635000	3525	DFT-s-OFDM QPSK	1@268	25.3	23.41	0.2193
77	15	50	635000	3525	DFT-s-OFDM 16 QAM	135@67	24.58	22.69	0.1858
77	15	50	635000	3525	DFT-s-OFDM 16 QAM	1@1	24.65	22.76	0.1888
77	15	50	635000	3525	DFT-s-OFDM 16 QAM	1@268	25.05	23.16	0.2070
77	15	50	635000	3525	DFT-s-OFDM 64 QAM	135@67	23.04	21.15	0.1303
77	15	50	635000	3525	DFT-s-OFDM 64 QAM	1@1	22.84	20.95	0.1245
77	15	50	635000	3525	DFT-s-OFDM 64 QAM	1@268	22.68	20.79	0.1199
77	15	50	635000	3525	DFT-s-OFDM 256 QAM	135@67	21.21	19.32	0.0855
77	15	50	635000	3525	DFT-s-OFDM 256 QAM	1@1	21.06	19.17	0.0826
77	15	50	635000	3525	DFT-s-OFDM 256 QAM	1@268	20.94	19.05	0.0804
77	15	50	635000	3525	CP-OFDM QPSK	135@67	24.53	22.64	0.1837
77	15	50	635000	3525	CP-OFDM QPSK	1@1	24.04	22.15	0.1641
77	15	50	635000	3525	CP-OFDM QPSK	1@268	24.5	22.61	0.1824

Frequency Stability

NR Band	SCS (kHz)	Bandwidth (MHz)	Arfcn	Freq (MHz)	Modulation	RB	Deviation (ppm)	Verdict	Environment
77	15	20	633334	3500.01	DFT-s-OFDM QPSK	100@0	0.00326	PASS	NV
77	15	20	633334	3500.01	DFT-s-OFDM QPSK	100@0	-0.00424	PASS	LV
77	15	20	633334	3500.01	DFT-s-OFDM QPSK	100@0	0.00369	PASS	HV
77	15	20	633334	3500.01	DFT-s-OFDM QPSK	100@0	0.00296	PASS	-30°C
77	15	20	633334	3500.01	DFT-s-OFDM QPSK	100@0	0.00341	PASS	-20°C
77	15	20	633334	3500.01	DFT-s-OFDM QPSK	100@0	0.00263	PASS	-10°C
77	15	20	633334	3500.01	DFT-s-OFDM QPSK	100@0	-0.00394	PASS	0°C
77	15	20	633334	3500.01	DFT-s-OFDM QPSK	100@0	0.00254	PASS	10°C
77	15	20	633334	3500.01	DFT-s-OFDM QPSK	100@0	0.00337	PASS	20°C
77	15	20	633334	3500.01	DFT-s-OFDM QPSK	100@0	-0.00351	PASS	30°C
77	15	20	633334	3500.01	DFT-s-OFDM QPSK	100@0	0.00235	PASS	40°C
77	15	20	633334	3500.01	DFT-s-OFDM QPSK	100@0	0.00367	PASS	50°C

Peak to Average Ratio

NR Band	SCS (kHz)	Bandwidth (MHz)	Arfcn	Freq (MHz)	Modulation	RB	Result (dB)	Limit (dB)	Verdict
77	15	20	633334	3500.01	DFT-s-OFDM PI/2 BPSK	100@0	3.96	13	PASS
77	15	20	633334	3500.01	DFT-s-OFDM PI/2 BPSK	1@0	3.82	13	PASS
77	15	20	633334	3500.01	DFT-s-OFDM QPSK	100@0	5.01	13	PASS
77	15	20	633334	3500.01	DFT-s-OFDM QPSK	1@0	4.77	13	PASS

N77(20M)_DFT-s-OFDM_PI_2-BPSK_Outer_Full_Mid_CH

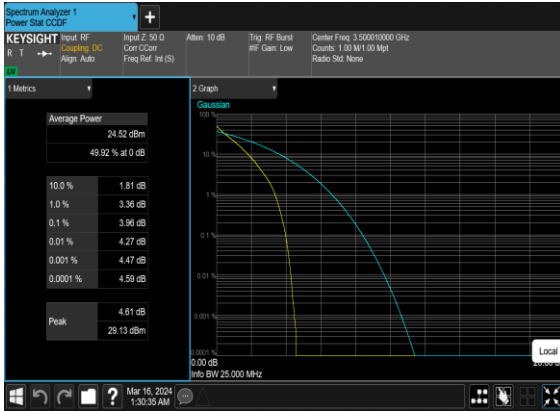

N77(20M)_DFT-s-OFDM_PI_2-BPSK_Edge_1RB_Left_Mid_CH

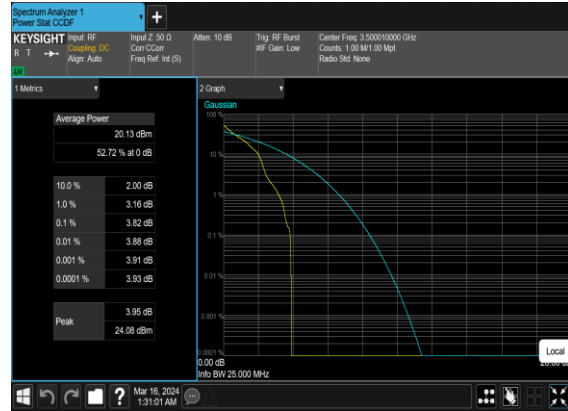

N77(20M)_DFT-s-OFDM_QPSK_Outer_Full_Mid_CH

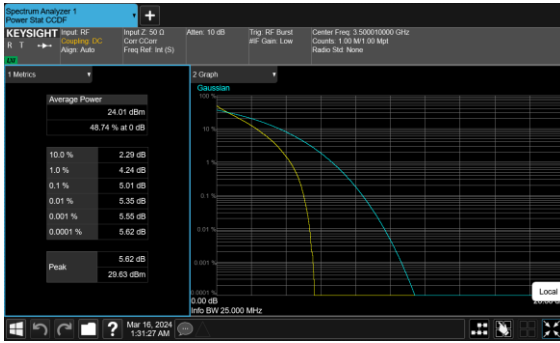

N77(20M)_DFT-s-OFDM_QPSK_Edge_1RB_Left_Mid_CH



Occupied Bandwidth

NR Band	SCS (kHz)	Bandwidth (MHz)	Arfcn	Freq (MHz)	Modulation	RB	OBW (MHz)	26dB BW (MHz)
77	15	10	633334	3500.01	CP-OFDM QPSK	52@0	9.2964	9.601
77	15	10	633334	3500.01	CP-OFDM 16 QAM	52@0	9.2561	9.628
77	15	10	633334	3500.01	CP-OFDM 64 QAM	52@0	9.2821	9.624
77	15	10	633334	3500.01	CP-OFDM 256 QAM	52@0	9.2792	9.746
77	15	15	633334	3500.01	CP-OFDM QPSK	79@0	14.098	14.59
77	15	15	633334	3500.01	CP-OFDM 16 QAM	79@0	14.076	14.59
77	15	15	633334	3500.01	CP-OFDM 64 QAM	79@0	14.15	14.57
77	15	15	633334	3500.01	CP-OFDM 256 QAM	79@0	14.088	14.57
77	15	20	633334	3500.01	CP-OFDM QPSK	106@0	18.947	19.54
77	15	20	633334	3500.01	CP-OFDM 16 QAM	106@0	18.83	19.6
77	15	20	633334	3500.01	CP-OFDM 64 QAM	106@0	18.9	19.54
77	15	20	633334	3500.01	CP-OFDM 256 QAM	106@0	18.872	19.57
77	15	25	633334	3500.01	CP-OFDM QPSK	133@0	23.729	24.59
77	15	25	633334	3500.01	CP-OFDM 16 QAM	133@0	23.82	24.64
77	15	25	633334	3500.01	CP-OFDM 64 QAM	133@0	23.719	24.61
77	15	25	633334	3500.01	CP-OFDM 256 QAM	133@0	23.699	24.62
77	15	30	633334	3500.01	CP-OFDM QPSK	160@0	28.591	29.61
77	15	30	633334	3500.01	CP-OFDM 16 QAM	160@0	28.542	29.48
77	15	30	633334	3500.01	CP-OFDM 64 QAM	160@0	28.474	29.56
77	15	30	633334	3500.01	CP-OFDM 256 QAM	160@0	28.523	29.69
77	15	40	633334	3500.01	CP-OFDM QPSK	216@0	38.435	39.9
77	15	40	633334	3500.01	CP-OFDM 16 QAM	216@0	38.591	39.81
77	15	40	633334	3500.01	CP-OFDM 64 QAM	216@0	38.524	39.82
77	15	40	633334	3500.01	CP-OFDM 256 QAM	216@0	38.564	39.83
77	15	50	633334	3500.01	CP-OFDM QPSK	270@0	48.157	49.72
77	15	50	633334	3500.01	CP-OFDM 16 QAM	270@0	48.118	49.73
77	15	50	633334	3500.01	CP-OFDM 64 QAM	270@0	48.093	49.66
77	15	50	633334	3500.01	CP-OFDM 256 QAM	270@0	48.204	49.75

N77(10M)_CP-OFDM_QPSK_Outer_Full_Mid_CH

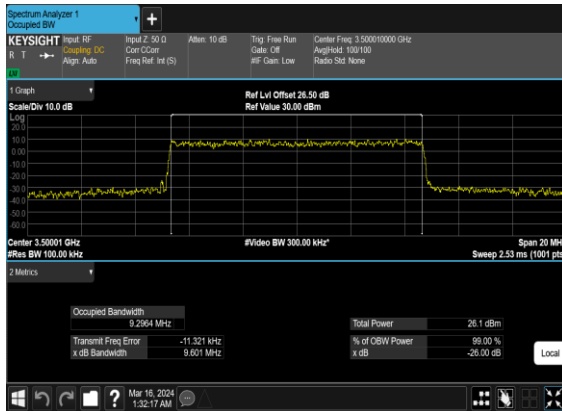

N77(10M)_CP-OFDM_16 QAM_Outer_Full_Mid_CH

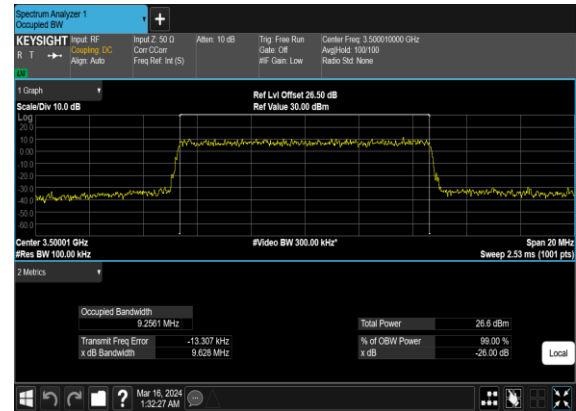

N77(10M)_CP-OFDM_64 QAM_Outer_Full_Mid_CH

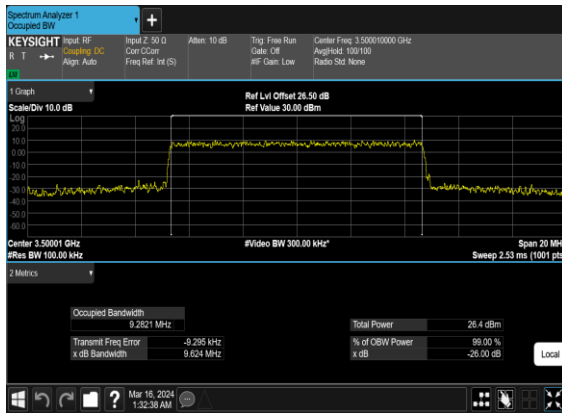

N77(10M)_CP-OFDM_256 QAM_Outer_Full_Mid_CH

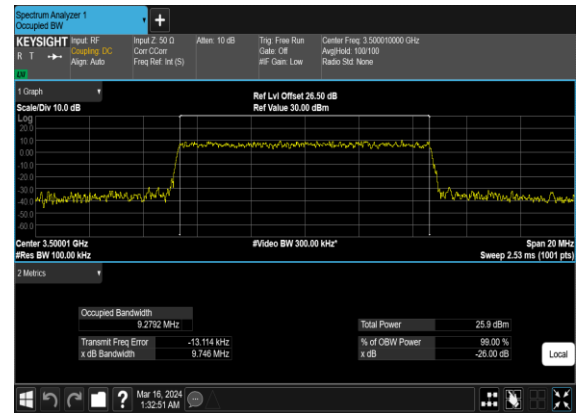

N77(15M)_CP-OFDM_QPSK_Outer_Full_Mid_CH

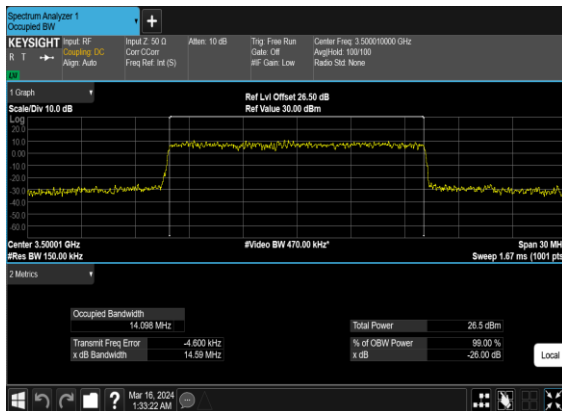

N77(15M)_CP-OFDM_16 QAM_Outer_Full_Mid_CH

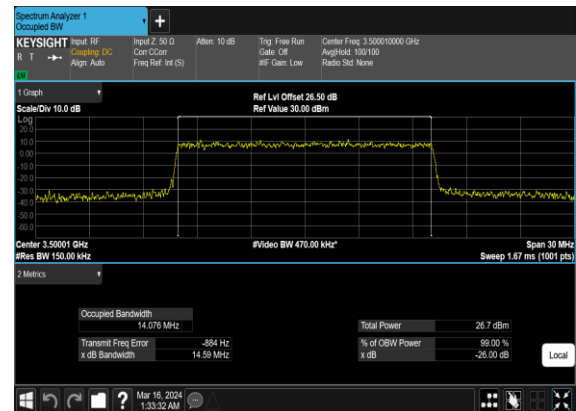

N77(15M)_CP-OFDM_64 QAM_Outer_Full_Mid_CH

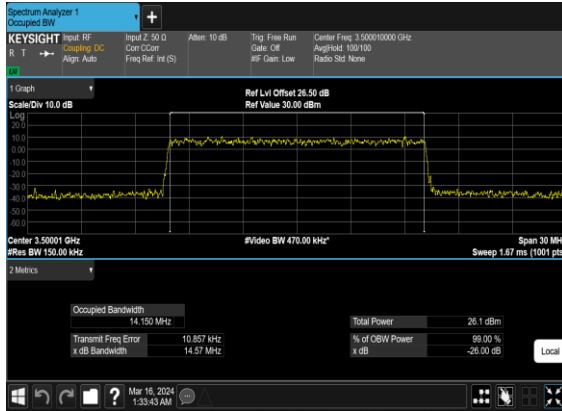

N77(15M)_CP-OFDM_256 QAM_Outer_Full_Mid_CH

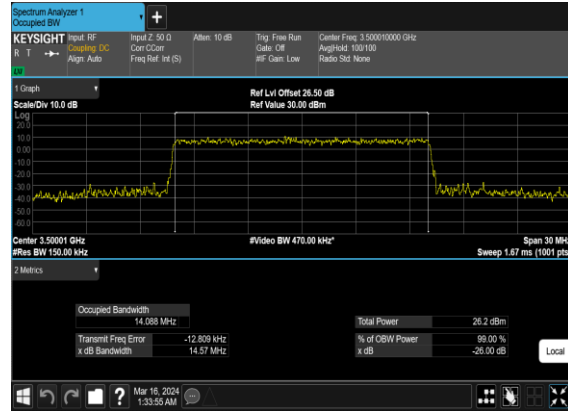

N77(20M)_CP- OFDM_QPSK_Outer_Full_Mid_CH

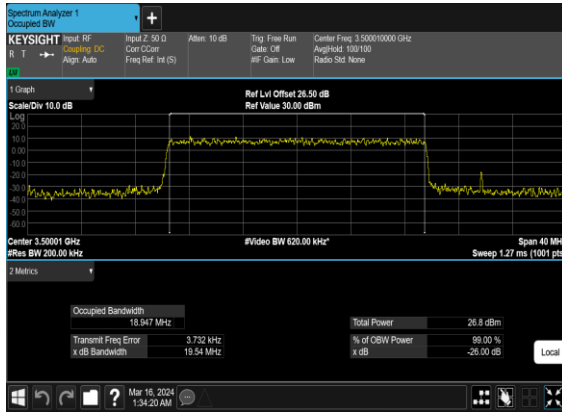

N77(20M)_CP-OFDM_16 QAM_Outer_Full_Mid_CH



N77(20M)_CP-OFDM_64 QAM_Outer_Full_Mid_CH

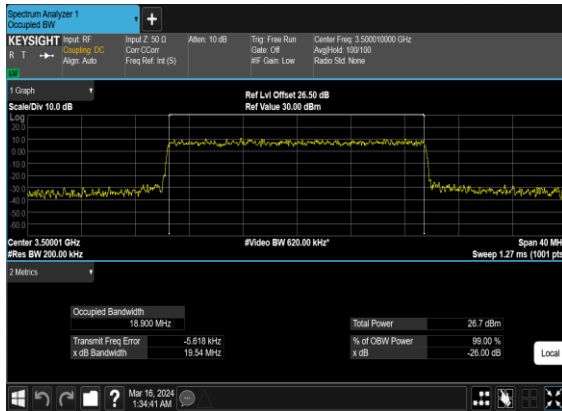

N77(20M)_CP-OFDM_256 QAM_Outer_Full_Mid_CH

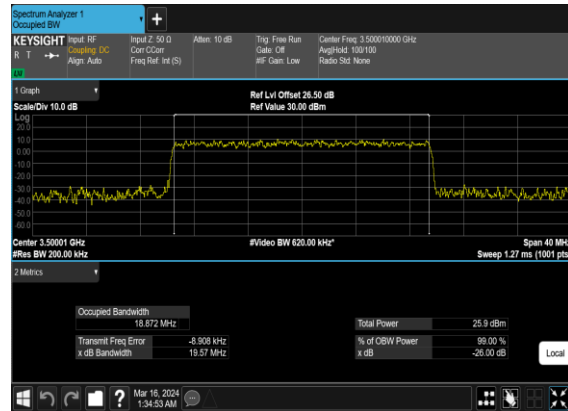

N77(25M)_CP-OFDM_QPSK_Outer_Full_Mid_CH

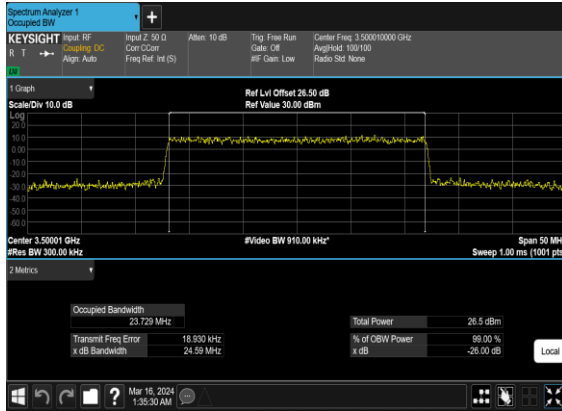

N77(25M)_CP-OFDM_16QAM_Outer_Full_Mid_CH

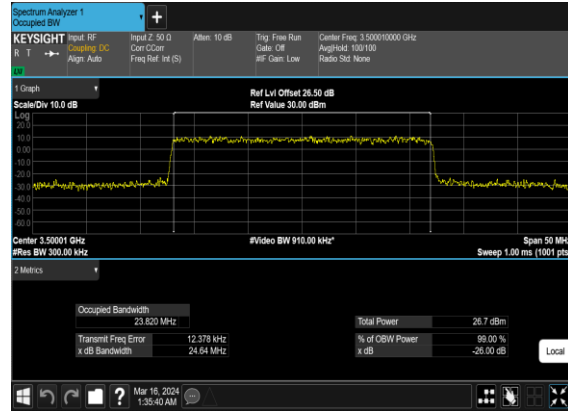

N77(25M)_CP-OFDM_64QAM_Outer_Full_Mid_CH



N77(25M)_CP-OFDM_256QAM_Outer_Full_Mid_CH

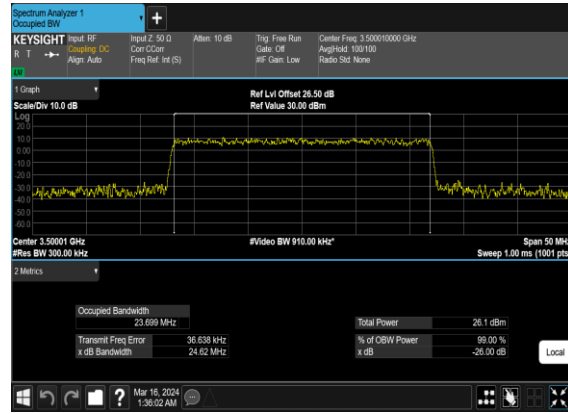

N77(30M)_CP-OFDM_QPSK_Outer_Full_Mid_CH

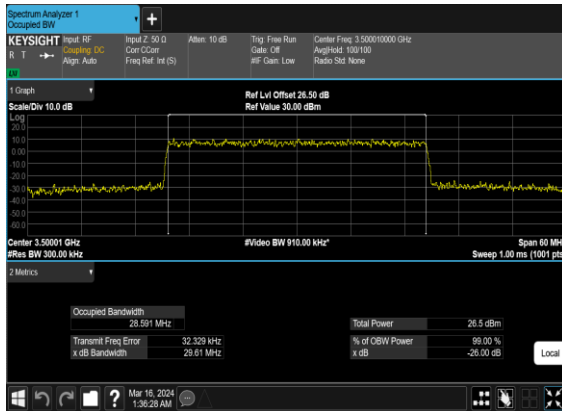

N77(30M)_CP-OFDM_16QAM_Outer_Full_Mid_CH

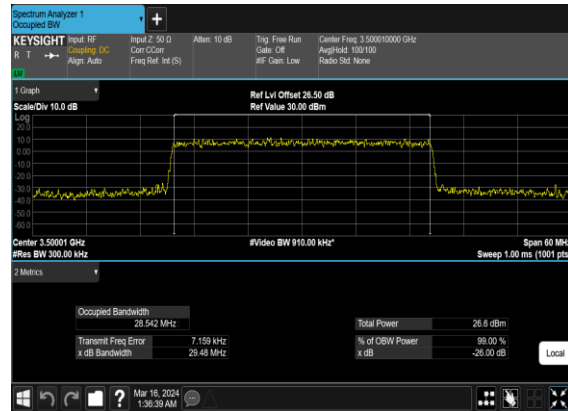

N77(30M)_CP-OFDM_64 QAM_Outer_Full_Mid_CH

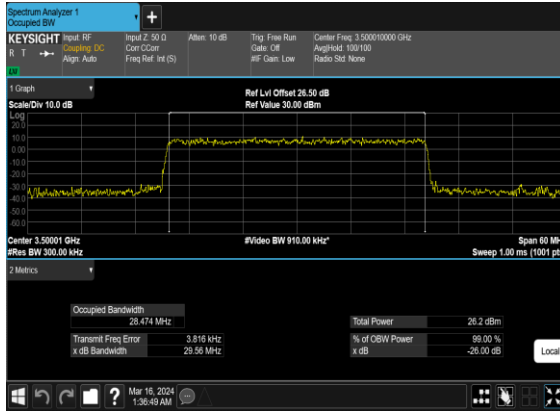

N77(30M)_CP-OFDM_256 QAM_Outer_Full_Mid_CH

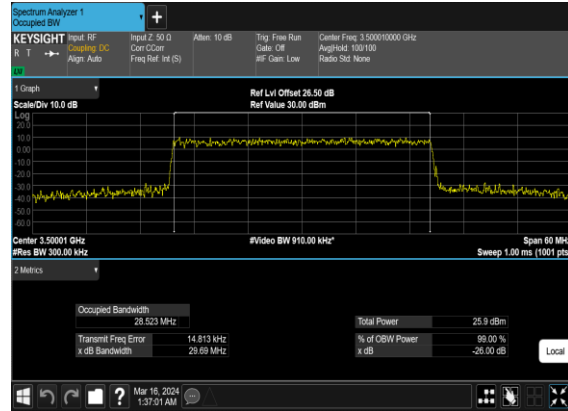

N77(40M)_CP- OFDM_QPSK_Outer_Full_Mid_CH

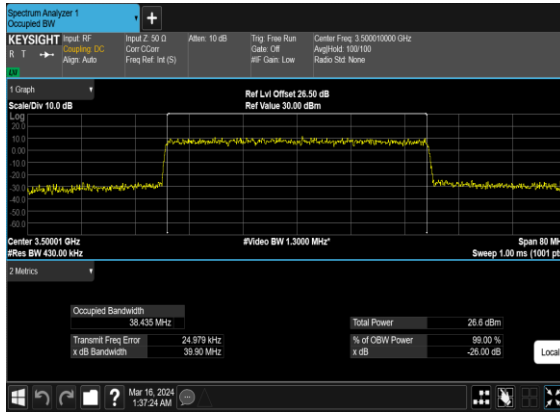

N77(40M)_CP-OFDM_16 QAM_Outer_Full_Mid_CH

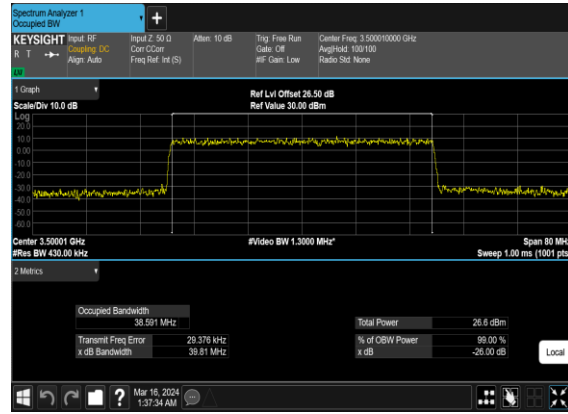

N77(40M)_CP-OFDM_64 QAM_Outer_Full_Mid_CH

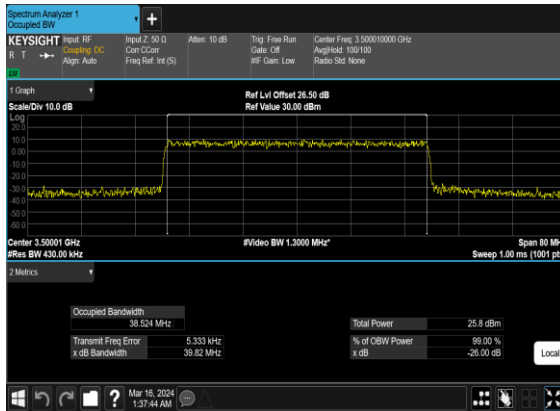

N77(40M)_CP-OFDM_256 QAM_Outer_Full_Mid_CH

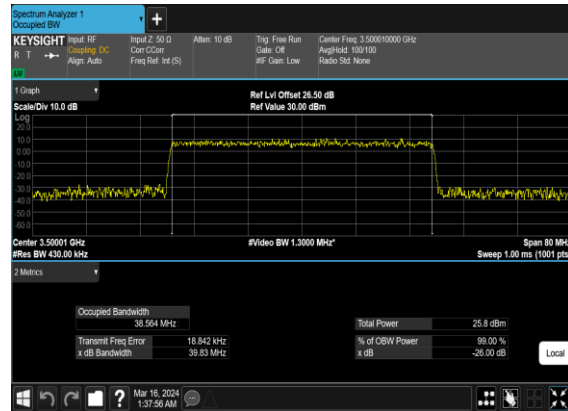

N77(50M)_CP-OFDM_QPSK_Outer_Full_Mid_CH

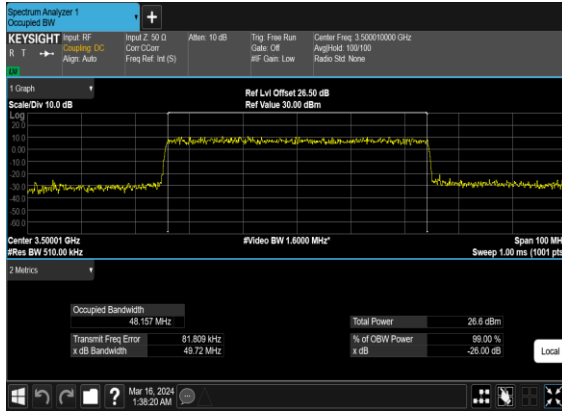

N77(50M)_CP-OFDM_16QAM_Outer_Full_Mid_CH

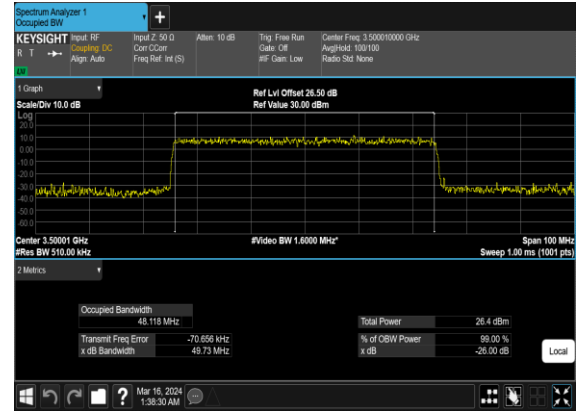

N77(50M)_CP-OFDM_64QAM_Outer_Full_Mid_CH

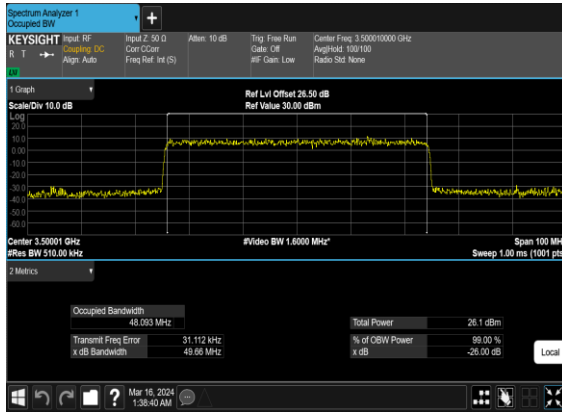

N77(50M)_CP-OFDM_256QAM_Outer_Full_Mid_CH



Conducted Spurious Emissions

NR Band	SCS (kHz)	Bandwidth (MHz)	Arcfn	Freq (MHz)	Modulation	RB	Result	Verdict
77	15	10	630334	3455.01	DFT-s-OFDM BPSK	1@0	see graph	---
77	15	10	630334	3455.01	DFT-s-OFDM BPSK	1@0	see graph	PASS
77	15	10	630334	3455.01	DFT-s-OFDM BPSK	1@0	see graph	PASS
77	15	10	630334	3455.01	DFT-s-OFDM QPSK	1@0	see graph	---
77	15	10	630334	3455.01	DFT-s-OFDM QPSK	1@0	see graph	PASS
77	15	10	630334	3455.01	DFT-s-OFDM QPSK	1@0	see graph	PASS
77	15	10	633334	3500.01	DFT-s-OFDM BPSK	1@0	see graph	---
77	15	10	633334	3500.01	DFT-s-OFDM BPSK	1@0	see graph	PASS
77	15	10	633334	3500.01	DFT-s-OFDM BPSK	1@0	see graph	PASS
77	15	10	633334	3500.01	DFT-s-OFDM QPSK	1@0	see graph	---
77	15	10	633334	3500.01	DFT-s-OFDM QPSK	1@0	see graph	PASS
77	15	10	633334	3500.01	DFT-s-OFDM QPSK	1@0	see graph	PASS
77	15	10	636333	3544.995	DFT-s-OFDM BPSK	1@0	see graph	---
77	15	10	636333	3544.995	DFT-s-OFDM BPSK	1@0	see graph	PASS
77	15	10	636333	3544.995	DFT-s-OFDM BPSK	1@0	see graph	PASS
77	15	10	636333	3544.995	DFT-s-OFDM QPSK	1@0	see graph	---
77	15	10	636333	3544.995	DFT-s-OFDM QPSK	1@0	see graph	PASS
77	15	10	636333	3544.995	DFT-s-OFDM QPSK	1@0	see graph	PASS
77	15	25	630834	3462.51	DFT-s-OFDM BPSK	1@0	see graph	---
77	15	25	630834	3462.51	DFT-s-OFDM BPSK	1@0	see graph	PASS
77	15	25	630834	3462.51	DFT-s-OFDM BPSK	1@0	see graph	PASS
77	15	25	630834	3462.51	DFT-s-OFDM QPSK	1@0	see graph	---
77	15	25	630834	3462.51	DFT-s-OFDM QPSK	1@0	see graph	PASS
77	15	25	630834	3462.51	DFT-s-OFDM QPSK	1@0	see graph	PASS
77	15	25	633334	3500.01	DFT-s-OFDM BPSK	1@0	see graph	---
77	15	25	633334	3500.01	DFT-s-OFDM BPSK	1@0	see graph	PASS

77	15	25	633334	3500.01	DFT-s-OFDM BPSK	1@0	see graph	PASS
77	15	25	633334	3500.01	DFT-s-OFDM QPSK	1@0	see graph	---
77	15	25	633334	3500.01	DFT-s-OFDM QPSK	1@0	see graph	PASS
77	15	25	633334	3500.01	DFT-s-OFDM QPSK	1@0	see graph	PASS
77	15	25	635833	3537.495	DFT-s-OFDM BPSK	1@0	see graph	---
77	15	25	635833	3537.495	DFT-s-OFDM BPSK	1@0	see graph	PASS
77	15	25	635833	3537.495	DFT-s-OFDM BPSK	1@0	see graph	PASS
77	15	25	635833	3537.495	DFT-s-OFDM QPSK	1@0	see graph	---
77	15	25	635833	3537.495	DFT-s-OFDM QPSK	1@0	see graph	PASS
77	15	25	635833	3537.495	DFT-s-OFDM QPSK	1@0	see graph	PASS
77	15	25	635833	3537.495	DFT-s-OFDM QPSK	1@0	see graph	PASS
77	15	50	631667	3475.005	DFT-s-OFDM BPSK	1@0	see graph	---
77	15	50	631667	3475.005	DFT-s-OFDM BPSK	1@0	see graph	PASS
77	15	50	631667	3475.005	DFT-s-OFDM BPSK	1@0	see graph	PASS
77	15	50	631667	3475.005	DFT-s-OFDM QPSK	1@0	see graph	---
77	15	50	631667	3475.005	DFT-s-OFDM QPSK	1@0	see graph	PASS
77	15	50	631667	3475.005	DFT-s-OFDM QPSK	1@0	see graph	PASS
77	15	50	633334	3500.01	DFT-s-OFDM BPSK	1@0	see graph	---
77	15	50	633334	3500.01	DFT-s-OFDM BPSK	1@0	see graph	PASS
77	15	50	633334	3500.01	DFT-s-OFDM BPSK	1@0	see graph	PASS
77	15	50	633334	3500.01	DFT-s-OFDM QPSK	1@0	see graph	---
77	15	50	633334	3500.01	DFT-s-OFDM QPSK	1@0	see graph	PASS
77	15	50	633334	3500.01	DFT-s-OFDM QPSK	1@0	see graph	PASS
77	15	50	635000	3525.0	DFT-s-OFDM BPSK	1@0	see graph	---
77	15	50	635000	3525.0	DFT-s-OFDM BPSK	1@0	see graph	PASS
77	15	50	635000	3525.0	DFT-s-OFDM BPSK	1@0	see graph	PASS
77	15	50	635000	3525.0	DFT-s-OFDM QPSK	1@0	see graph	---
77	15	50	635000	3525.0	DFT-s-OFDM QPSK	1@0	see graph	PASS
77	15	50	635000	3525.0	DFT-s-OFDM QPSK	1@0	see graph	PASS

N77(10M)_DFT-s-OFDM_BPSK_Edge_1RB_Left_Low_CH



N77(10M)_DFT-s-OFDM_BPSK_Edge_1RB_Left_Low_CH

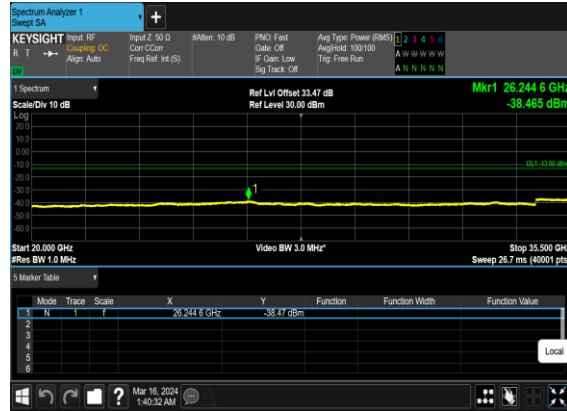

N77(10M)_DFT-s-OFDM_QPSK_Edge_1RB_Left_Low_CH

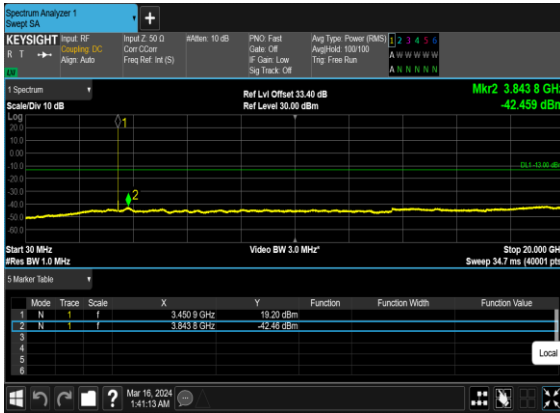

N77(10M)_DFT-s-OFDM_QPSK_Edge_1RB_Left_Low_CH

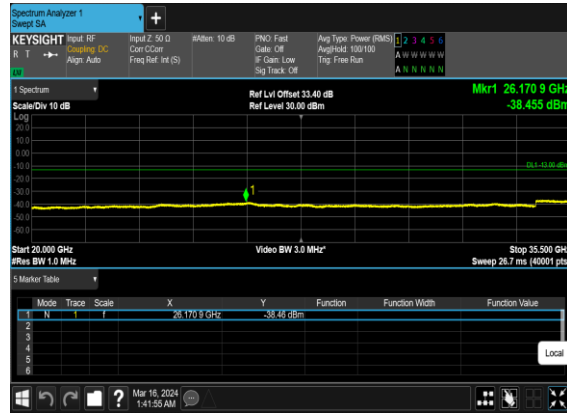

N77(10M)_DFT-s-OFDM_BPSK_Edge_1RB_Left_Mid_CH

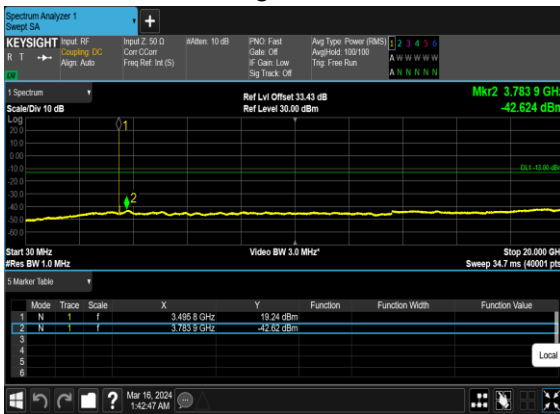

N77(10M)_DFT-s-OFDM_BPSK_Edge_1RB_Left_Mid_CH

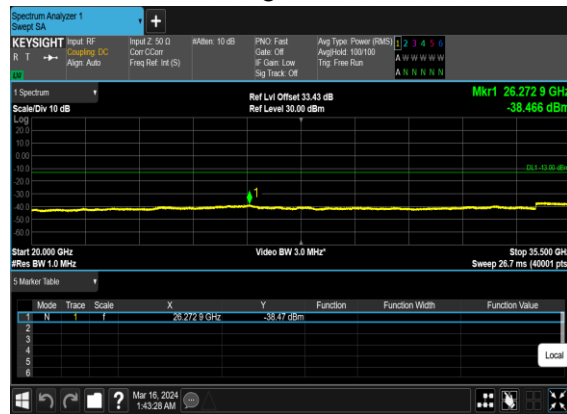

N77(10M)_DFT-s-OFDM_QPSK_Edge_1RB_Left_Mid_CH

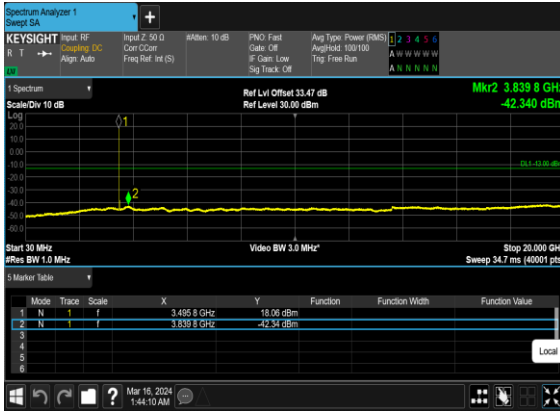

N77(10M)_DFT-s-OFDM_QPSK_Edge_1RB_Left_Mid_CH

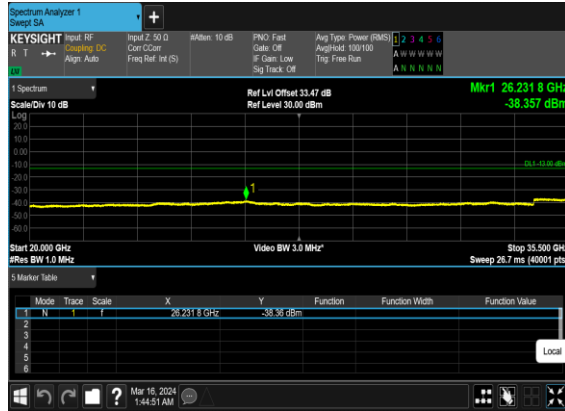

N77(10M)_DFT-s-OFDM_BPSK_Edge_1RB_Left_High_CH



N77(10M)_DFT-s-OFDM_BPSK_Edge_1RB_Left_High_CH

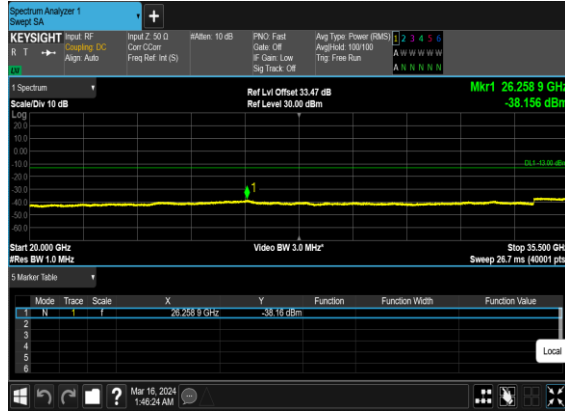

N77(10M)_DFT-s-OFDM_QPSK_Edge_1RB_Left_High_CH



N77(10M)_DFT-s-OFDM_QPSK_Edge_1RB_Left_High_CH

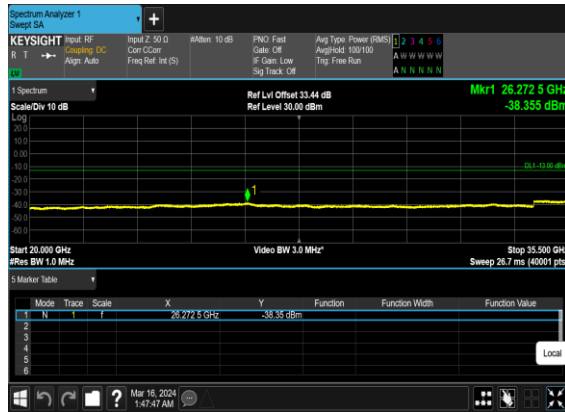

N77(25M)_DFT-s-OFDM_BPSK_Edge_1RB_Left_Low_CH



N77(25M)_DFT-s-OFDM_BPSK_Edge_1RB_Left_Low_CH

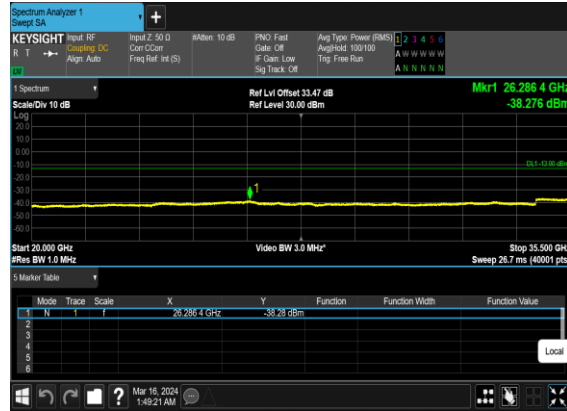

N77(25M)_DFT-s-OFDM_QPSK_Edge_1RB_Left_Low_CH



N77(25M)_DFT-s-OFDM_QPSK_Edge_1RB_Left_Low_CH

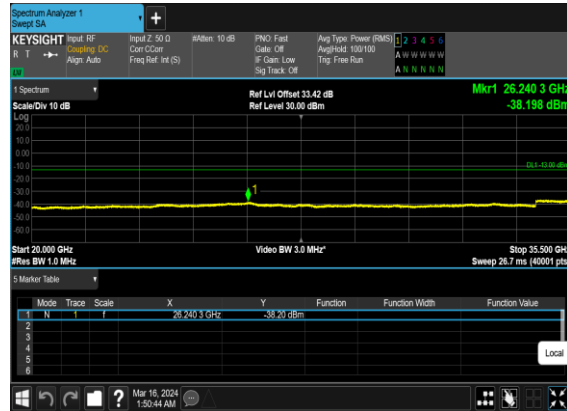

N77(25M)_DFT-s-OFDM_BPSK_Edge_1RB_Left_Mid_CH

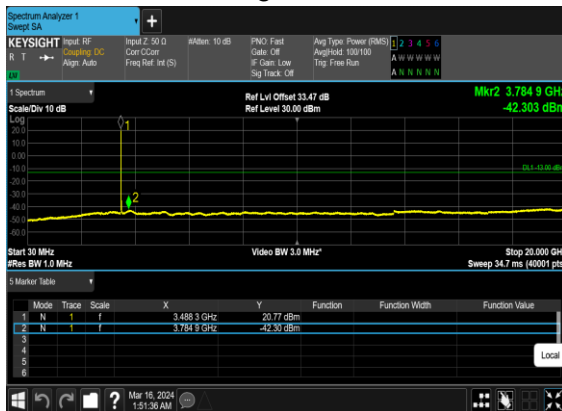

N77(25M)_DFT-s-OFDM_BPSK_Edge_1RB_Left_Mid_CH

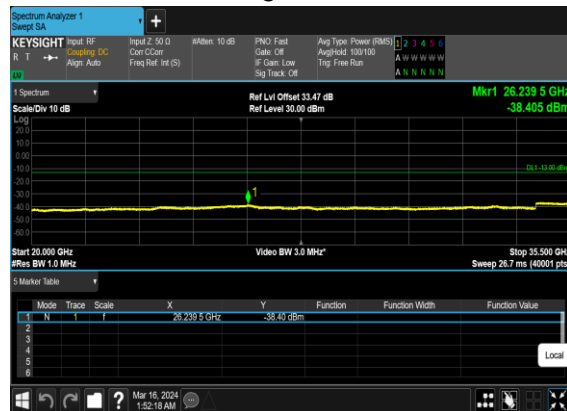

N77(25M)_DFT-s-OFDM_QPSK_Edge_1RB_Left_Mid_CH

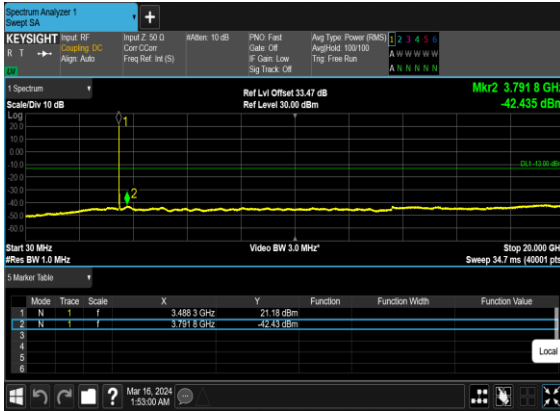

N77(25M)_DFT-s-OFDM_QPSK_Edge_1RB_Left_Mid_CH

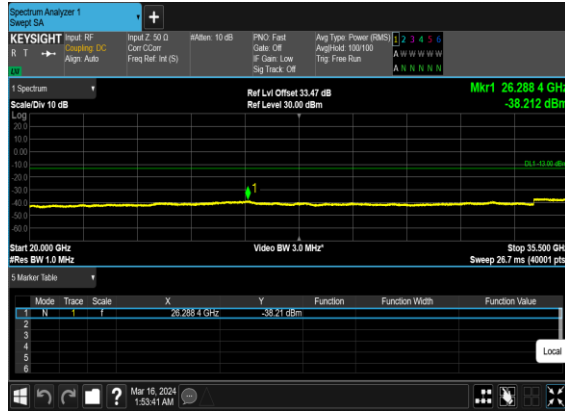

N77(25M)_DFT-s-OFDM_BPSK_Edge_1RB_Left_High_CH



N77(25M)_DFT-s-OFDM_BPSK_Edge_1RB_Left_High_CH



N77(25M)_DFT-s-OFDM_QPSK_Edge_1RB_Left_High_CH

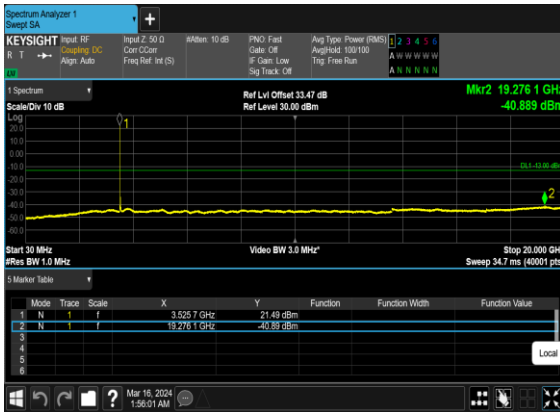

N77(25M)_DFT-s-OFDM_QPSK_Edge_1RB_Left_High_CH

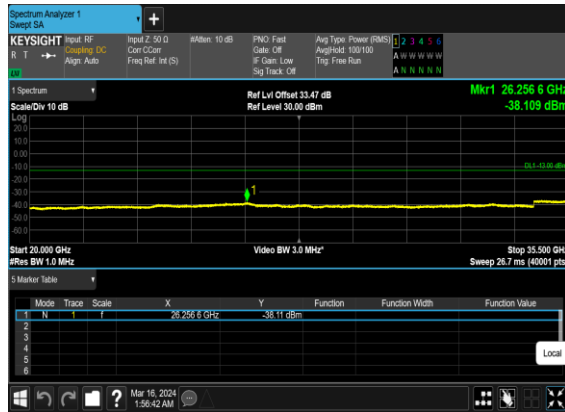

N77(50M)_DFT-s-OFDM_BPSK_Edge_1RB_Left_Low_CH

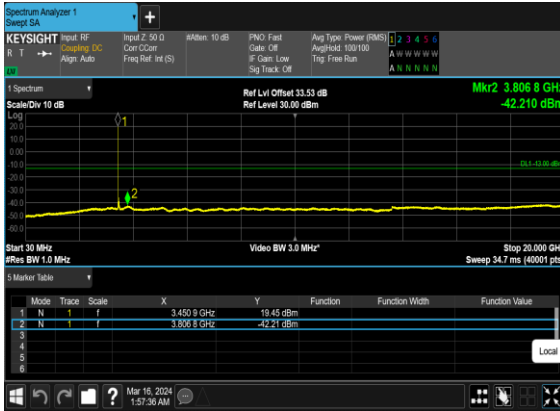

N77(50M)_DFT-s-OFDM_BPSK_Edge_1RB_Left_Low_CH

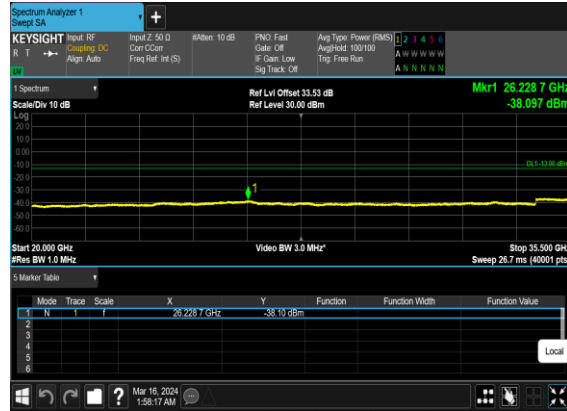

N77(50M)_DFT-s-OFDM_QPSK_Edge_1RB_Left_Low_CH

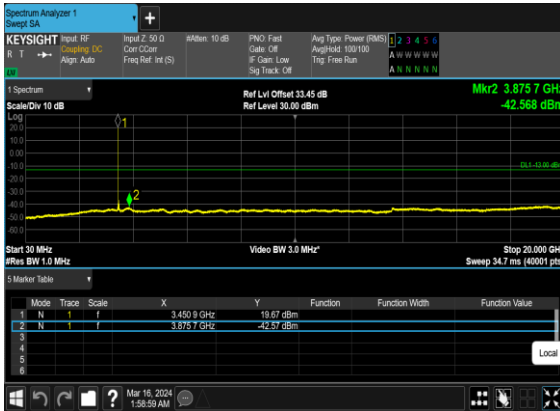

N77(50M)_DFT-s-OFDM_QPSK_Edge_1RB_Left_Low_CH

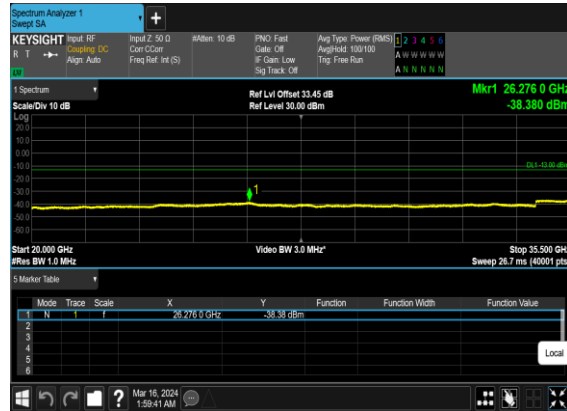

N77(50M)_DFT-s-OFDM_BPSK_Edge_1RB_Left_Mid_CH

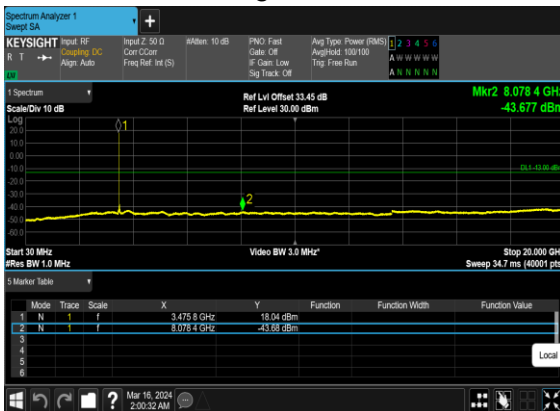

N77(50M)_DFT-s-OFDM_BPSK_Edge_1RB_Left_Mid_CH

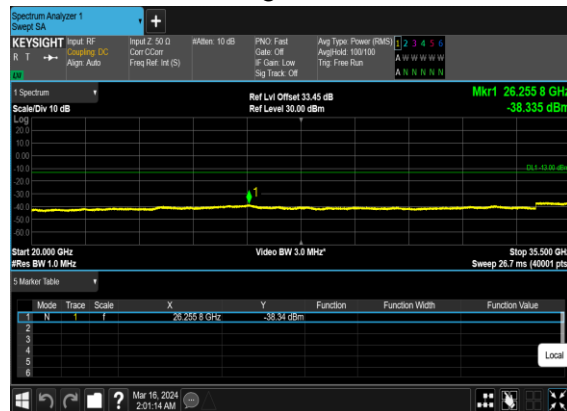

N77(50M)_DFT-s-OFDM_QPSK_Edge_1RB_Left_Mid_CH



N77(50M)_DFT-s-OFDM_QPSK_Edge_1RB_Left_Mid_CH

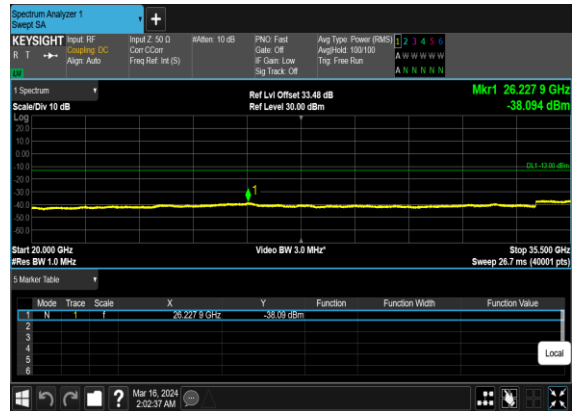

N77(50M)_DFT-s-OFDM_BPSK_Edge_1RB_Left_High_CH

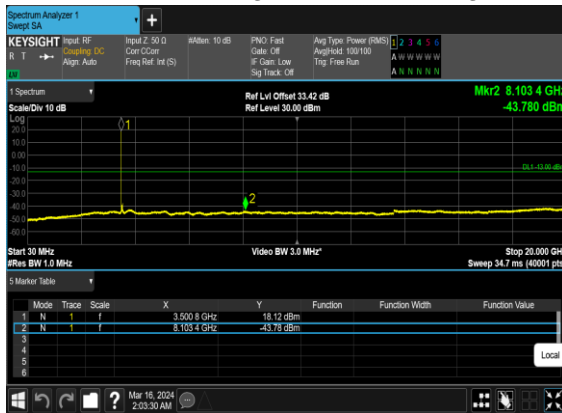

N77(50M)_DFT-s-OFDM_BPSK_Edge_1RB_Left_High_CH

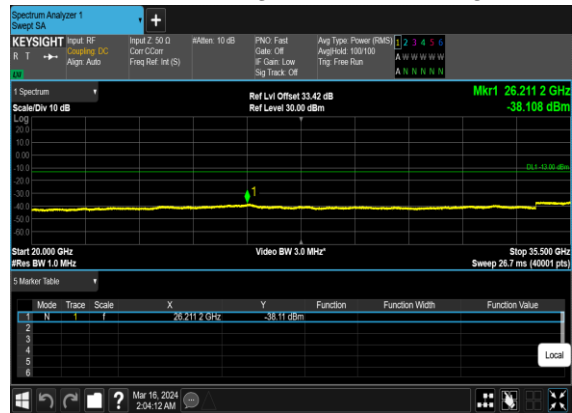

N77(50M)_DFT-s-OFDM_QPSK_Edge_1RB_Left_High_CH

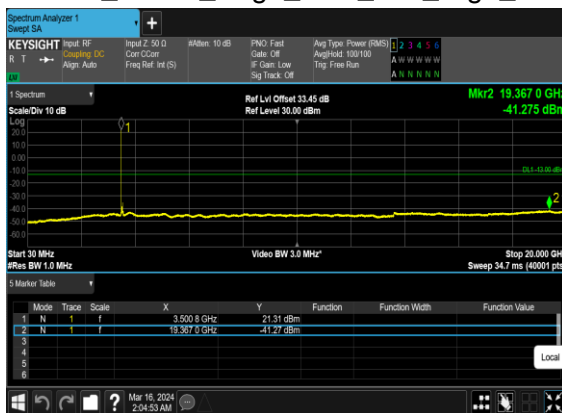

N77(50M)_DFT-s-OFDM_QPSK_Edge_1RB_Left_High_CH



Conducted Band Edge

NR Band	SCS (kHz)	Bandwidth (MHz)	Arfcn	Freq (MHz)	Modulation	RB	Result	Verdict
77	15	10	630334	3455.01	DFT-s-OFDM BPSK	1@0	see graph	PASS
77	15	10	630334	3455.01	DFT-s-OFDM QPSK	1@0	see graph	PASS
77	15	10	630334	3455.01	DFT-s-OFDM BPSK	50@0	see graph	PASS
77	15	10	630334	3455.01	DFT-s-OFDM QPSK	50@0	see graph	PASS
77	15	10	636333	3544.995	DFT-s-OFDM BPSK	1@51	see graph	PASS
77	15	10	636333	3544.995	DFT-s-OFDM QPSK	1@51	see graph	PASS
77	15	10	636333	3544.995	DFT-s-OFDM BPSK	50@0	see graph	PASS
77	15	10	636333	3544.995	DFT-s-OFDM QPSK	50@0	see graph	PASS
77	15	25	630834	3462.51	DFT-s-OFDM BPSK	1@0	see graph	PASS
77	15	25	630834	3462.51	DFT-s-OFDM QPSK	1@0	see graph	PASS
77	15	25	630834	3462.51	DFT-s-OFDM BPSK	128@0	see graph	PASS
77	15	25	630834	3462.51	DFT-s-OFDM QPSK	128@0	see graph	PASS
77	15	25	635833	3537.495	DFT-s-OFDM BPSK	1@132	see graph	PASS
77	15	25	635833	3537.495	DFT-s-OFDM QPSK	1@132	see graph	PASS
77	15	25	635833	3537.495	DFT-s-OFDM BPSK	128@0	see graph	PASS
77	15	25	635833	3537.495	DFT-s-OFDM QPSK	128@0	see graph	PASS
77	15	50	631667	3475.005	DFT-s-OFDM BPSK	1@0	see graph	PASS
77	15	50	631667	3475.005	DFT-s-OFDM QPSK	1@0	see graph	PASS
77	15	50	631667	3475.005	DFT-s-OFDM BPSK	270@0	see graph	PASS
77	15	50	631667	3475.005	DFT-s-OFDM QPSK	270@0	see graph	PASS
77	15	50	635000	3525.0	DFT-s-OFDM BPSK	1@269	see graph	PASS
77	15	50	635000	3525.0	DFT-s-OFDM QPSK	1@269	see graph	PASS
77	15	50	635000	3525.0	DFT-s-OFDM BPSK	270@0	see graph	PASS
77	15	50	635000	3525.0	DFT-s-OFDM QPSK	270@0	see graph	PASS

N77(10M)_DFT-s-OFDM_BPSK_Edge_1RB_Left_Low_CH

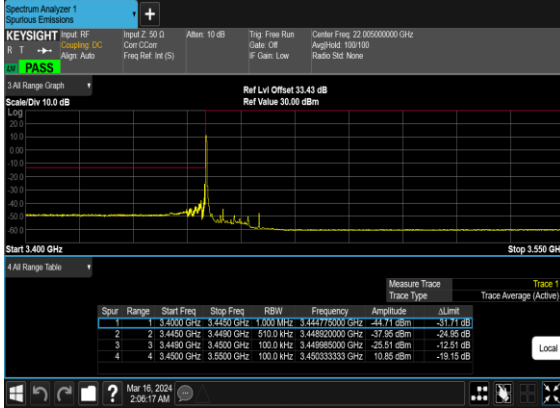

N77(10M)_DFT-s-OFDM_QPSK_Edge_1RB_Left_Low_CH

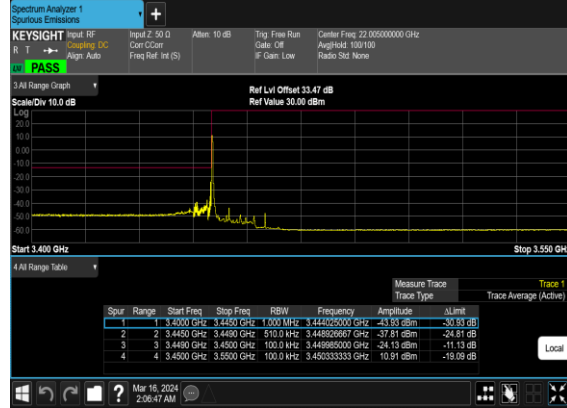

N77(10M)_DFT-s-OFDM_BPSK_Outer_Full_Low_CH

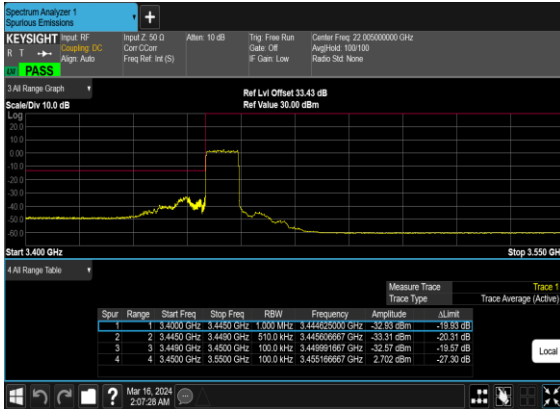

N77(10M)_DFT-s-OFDM_QPSK_Outer_Full_Low_CH

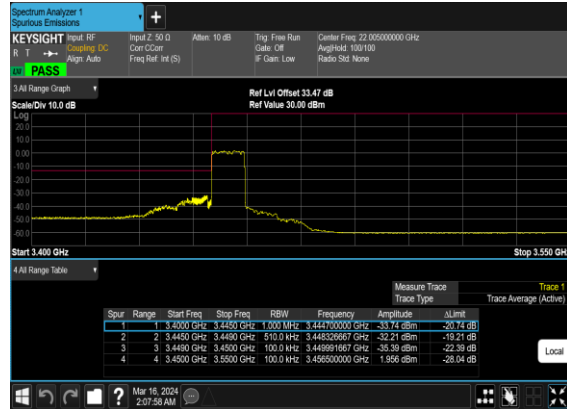

N77(10M)_DFT-s-OFDM_BPSK_Edge_1RB_Right_High_CH

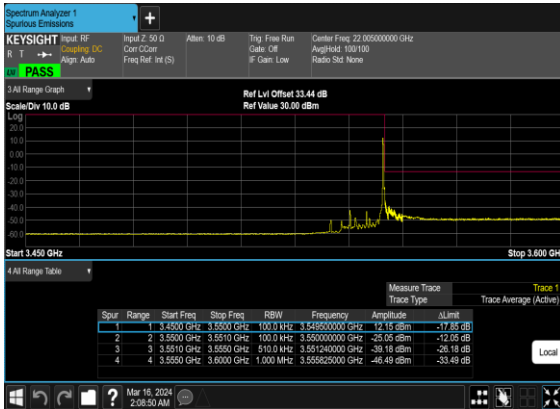

N77(10M)_DFT-s-OFDM_QPSK_Edge_1RB_Right_High_CH

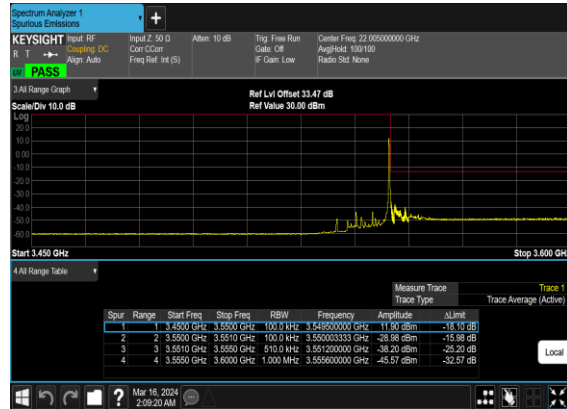

N77(10M)_DFT-s-OFDM_BPSK_Outer_Full_High_CH



N77(10M)_DFT-s-OFDM_QPSK_Outer_Full_High_CH

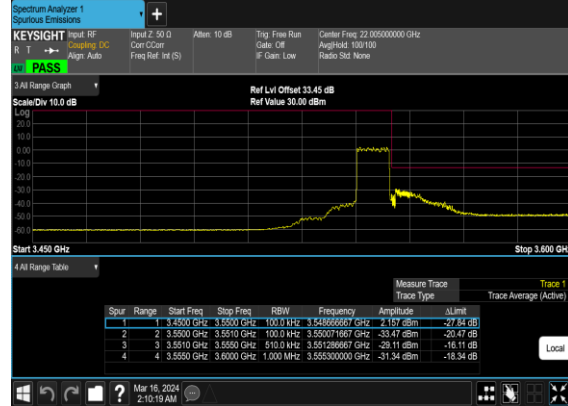

N77(25M)_DFT-s-OFDM_BPSK_Edge_1RB_Left_Low_CH

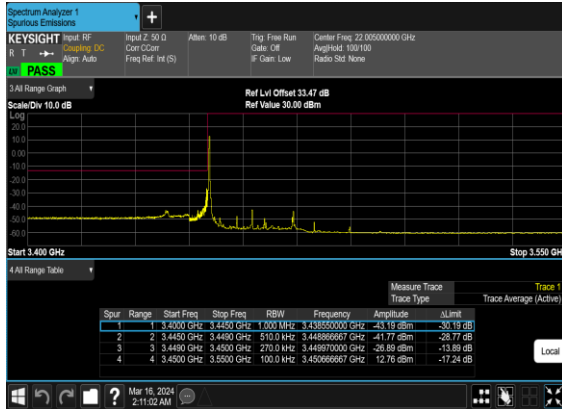

N77(25M)_DFT-s-OFDM_QPSK_Edge_1RB_Left_Low_CH

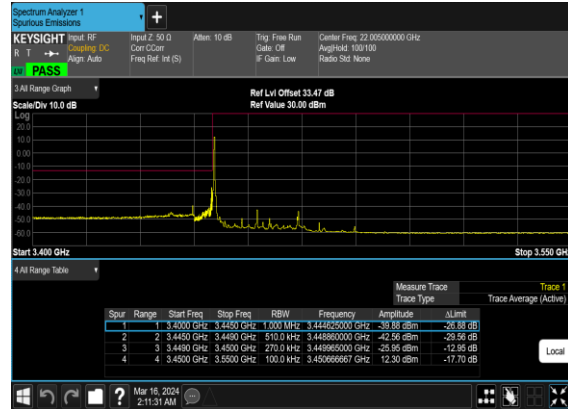

N77(25M)_DFT-s-OFDM_BPSK_Outer_Full_Low_CH

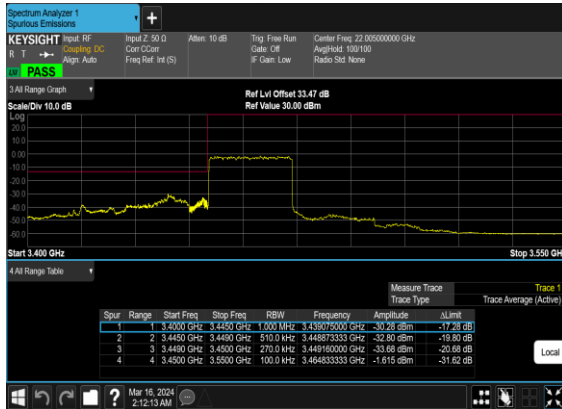

N77(25M)_DFT-s-OFDM_QPSK_Outer_Full_Low_CH

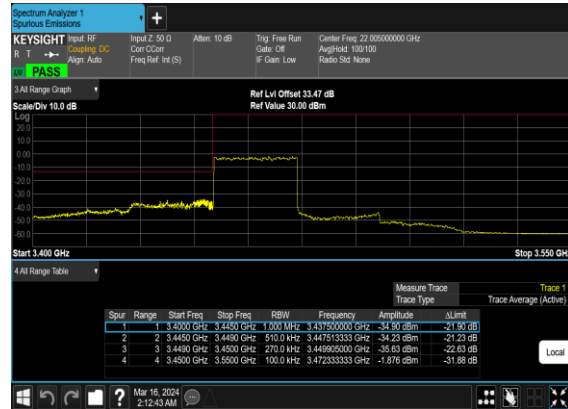

N77(25M)_DFT-s-OFDM_BPSK_Edge_1RB_Right_High_CH

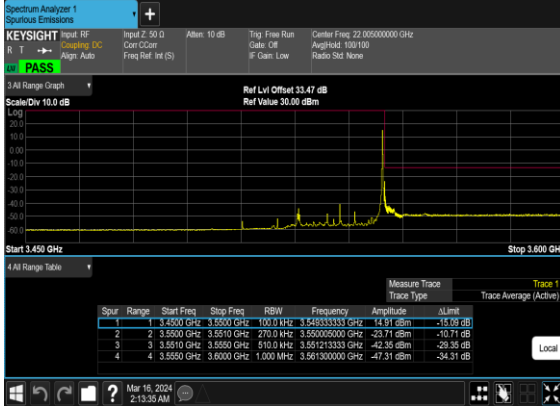

N77(25M)_DFT-s-OFDM_QPSK_Edge_1RB_Right_High_CH

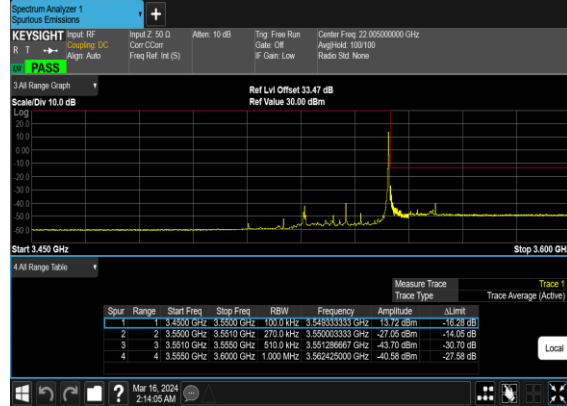

N77(25M)_DFT-s-OFDM_BPSK_Outer_Full_High_CH

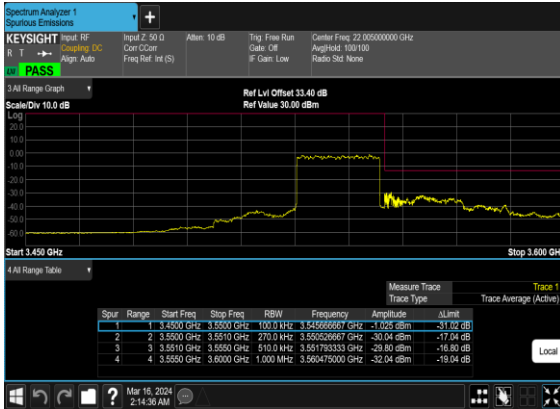

N77(25M)_DFT-s-OFDM_QPSK_Outer_Full_High_CH

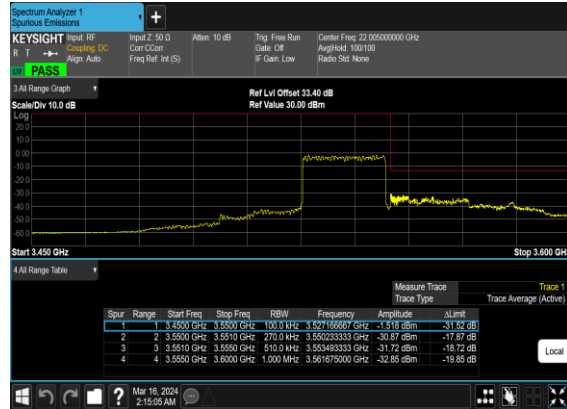

N77(50M)_DFT-s-OFDM_BPSK_Edge_1RB_Left_Low_CH

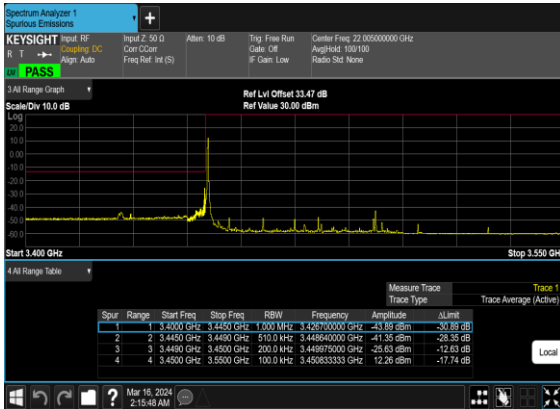

N77(50M)_DFT-s-OFDM_QPSK_Edge_1RB_Left_Low_CH

