

# RF Exposure Report

**FCC ID** : IHDT56AQ9  
**Equipment** : Mobile Cellular Phone  
**Brand Name** : Motorola  
**Model Name** : M-51E(XT2453-8)  
**Applicant** : Motorola Mobility LLC  
222 W,Merchandise Mart Plaza, Chicago IL 60654 USA  
**Manufacture** : Motorola Mobility LLC  
222 W,Merchandise Mart Plaza, Chicago IL 60654 USA  
**Standard** : FCC 47 CFR Part 2.1093

The product was received on Jun. 27, 2024 and testing was started from Jun. 27, 2024 and completed on Jun. 27, 2024. We, SPORTON INTERNATIONAL INC., would like to declare that the tested sample provide by manufacturer and the test data has been evaluated in accordance with the test procedures given in 47 CFR Part 2.1093 and has been pass the FCC requirement.

The results in this report apply exclusively to the tested model / sample. Without written approval of SPORTON INTERNATIONAL INC. Laboratory, the test report shall not be reproduced except in full.

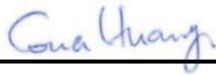

Approved by: Cona Huang / Deputy Manager



## **Sporton International Inc. Wensan Laboratory**

No.58, Aly. 75, Ln. 564, Wenhua 3rd, Rd., Guishan Dist., Taoyuan City 333010, Taiwan



## **Table of Contents**

1. DESCRIPTION OF EQUIPMENT UNDER TEST (EUT) .....4

2. RF EXPOSURE LIMIT .....4

3. SYSTEM DESCRIPTION AND SETUP .....5

4. EQUIPMENT LIST .....8

5. SYSTEM VALIDIATION .....8

6. RF EXPOSURE RESULTS.....9

    6.1. Maximum Permissible Exposure Evaluation .....9

    6.2. Peak Spatial-Average SAR Evaluation.....10

7. UNCERTAINTY.....11

8. REFERENCE .....13

**Appendix A. Plots of System Performance Check**

**Appendix B. Plots of Highest Measurement Result**

**Appendix C. DASYS Calibration Certificate**

**Appendix D. Test Setup Photo**



**Revision History**

REPORT NO.	VERSION	DESCRIPTION	ISSUED DATE
FA422218-09	Rev. 01	Initial issue of report	Jul. 05, 2024
FA422218-09	Rev. 02	Update frequency range	Sep. 27, 2024
FA422218-09	Rev. 03	Update model name	Oct. 28, 2024

## 1. Description of Equipment Under Test (EUT)

Product Feature & Specification	
FCC ID	IHDT56AQ9
Equipment	Mobile Cellular Phone
Brand Name	Motorola
Model Name	M-51E(XT2453-8)
Frequency Range	110KHz~148KHz
Mode	ASK

## 2. RF Exposure Limit

### <Limits for Maximum Permissible Exposure>

§ 1.1310 The criteria listed in table 1 shall be used to evaluate the environmental impact of human exposure to radio frequency(RF) radiation as specified in § 1.1307(b), except in the case of portable devices which shall be evaluated according to the provisions of § 2.1093 of this chapter.

Frequency range (MHz)	Electric field strength (V/m)	Magnetic field strength (A/m)	Power density (mW/cm <sup>2</sup> )	Averaging time (minutes)
(A) Limits for Occupational/Controlled Exposure				
0.3-3.0	614	1.63	* 100	6
3.0-30	1842/f	4.89/f	* 900/f <sup>2</sup>	6
30-300	61.4	0.163	1.0	6
300-1,500			f/300	6
1,500-100,000			5	6
(B) Limits for General Population/Uncontrolled Exposure				
0.3-1.34	614	1.63	* 100	30
1.34-30	824/f	2.19/f	* 180/f <sup>2</sup>	30
30-300	27.5	0.073	0.2	30
300-1,500			f/1500	30
1,500-100,000			1.0	30

f = frequency in MHz

\* = Plane-wave equivalent power density

(1) Occupational/controlled exposure limits apply in situations in which persons are exposed as a consequence of their employment provided those persons are fully aware of the potential for exposure and can exercise control over their exposure. Limits for occupational/controlled exposure also apply in situations when a person is transient through a location where occupational/controlled limits apply provided he or she is made aware of the potential for exposure. The phrase fully aware in the context of applying these exposure limits means that an exposed person has received written and/or verbal information fully explaining the potential for RF exposure resulting from his or her employment. With the exception of transient persons, this phrase also means that an exposed person has received appropriate training regarding work practices relating to controlling or mitigating his or her exposure. Such training is not required for transient persons, but they must receive written and/or verbal information and notification (for example, using signs) concerning their exposure potential and appropriate means available to mitigate their exposure. The phrase exercise control means that an exposed person is allowed to and knows how to reduce or avoid exposure by administrative or engineering controls and work practices, such as use of personal protective equipment or time averaging of exposure.

(2) General population/uncontrolled exposure limits apply in situations in which the general public may be exposed, or in which persons who are exposed as a consequence of their employment may not be fully aware of the potential for exposure or cannot exercise control over their exposure.

### <Limit for peak spatial-average SAR>

The SAR limits for general population/uncontrolled exposure are 0.08 W/kg, as averaged over the whole body, and a peak spatial-average SAR of 1.6 W/kg, averaged over any 1 gram of tissue (defined as a tissue volume in the shape of a cube). Exceptions are the parts of the human body treated as extremities, such as hands, wrists, feet, ankles, and pinnae, where the peak spatial-average SAR limit is 4 W/kg, averaged over any 10 grams of tissue (defined as a tissue volume in the shape of a cube). Exposure may be averaged over a time period not to exceed 30 minutes to determine compliance with general population/uncontrolled SAR limits.

### 3. System Description and Setup

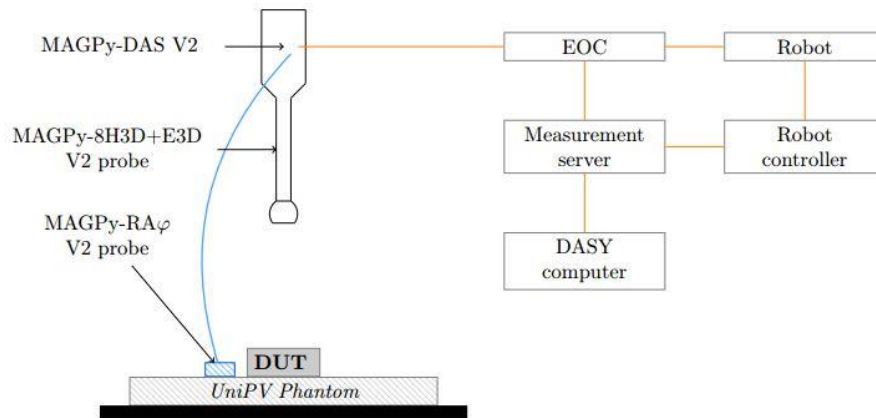

#### General Note:

1. DASY8 Module WPT v2.6+ is a special solution for high precision evaluations in the laboratory. The precision is achieved by combining the MAGPy system with the DASY robotics system and Sim4Life simulation platform. It is the first and only fully automated system for demonstrating compliance of WPT devices.
2. The setup figure shows a typical setup for the measurements with DASY8 Module WPT. The MAGPy-8H3D+E3D V2 probe with MAGPy-DAS V2 is mounted on a TX-90 or TX2-90 robot allowing to scan volumes as large as 2000 x 1000 x 1500 mm with a precision of  $\pm 0.2$  mm. The H-field distributions can be analyzed directly and the values are compared to the reference level, or they are converted into Maxwell field and used as excitations for determining the basic restriction quantities for further dosimetric analysis with the Magneto Quasi-Static (MQS) solver. This specific solution is optimized for evaluation of H-field sources (3kHz–10MHz) and demonstration of compliance (3KHz–4 MHz)
3. Since the DASY8 Module WPT system alternatively, curve-fitting techniques may be used to estimate the field value(s) at dsep based on measurements taken at larger distances. The test equipment permits the estimation of fields at 0mm separation distance based on measurements near the surface; Maxwell total field reconstruction is employed.
4. The DASY8 Module WPT with MAGPy-8H3D+E3D V2 Probe is capable of measuring the H-field in frequency and time-domain in the frequency band from 3 kHz to 10 MHz, covering a dynamic range from 0.1 to >3100 A/m.
5. The DASY8 Module WPT provides the relation between an externally applied H-field to each of the three sensors and the corresponding ADC reading over the frequency range from 3 kHz to 10 MHz. The frequency-dependent adjustment factors are used to determine the incident measured H-field from an ADC reading. For the frequency range from 1 to 10 MHz, the adjustment factors are applied with finite impulse response (FIR) filters directly inside the MAGPy-8H3D+E3D V2 in time-domain and frequencies <1 MHz in the frequency domain in the PC-based post-processing software.
6. In summary, this system of DASY8 Module WPT with MAGPy-8H3D+E3D V2 Probe fully meets the requirements of SPR002 Issue2 table A2

#### Probe Spec

The MAGPy-8H3D+E3D V2 probe consists of eight isotropic H-field sensors and one isotropic E-field sensor:  
Probe design:

- Probe length: 335 mm
- Probe tip diameter: 60 mm
- 8H3D: eight isotropic 1 cm<sup>3</sup>-H-field sensors, arranged at the corners of a 22 mm cube
- First isotropic H-field sensor plane: 7.5 mm from the tip
- E3D: one isotropic E-field sensor (dipole / monopole)

Sensor specifications:

- Frequency range: 3 kHz – 10 MHz
- H-field dynamic range: 0.1 A/m – 3200 A/m (0.12  $\mu$ T – 4 mT)
- H-field extrapolation uncertainty: 0.6 dB (k = 2)
- E-field dynamic range: 0.08 V/m – 2000 V/m

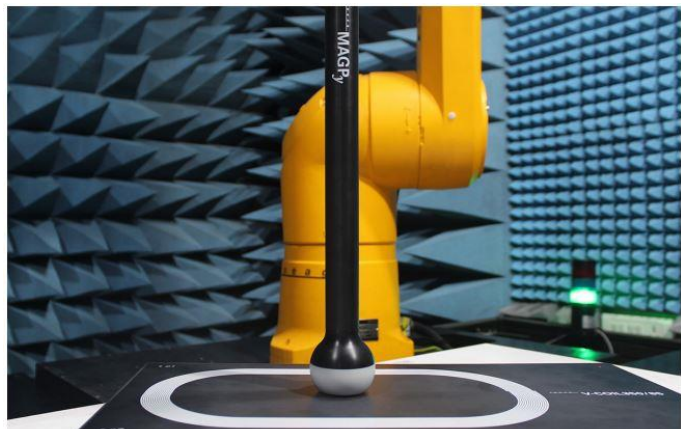



● **Compliance Evaluation**

DASY8 Module WPT SW version v2.6+ offers compliance evaluation with respect to:

- **Reference levels** on the basis of the incident *H*- and *E*-fields measured from the volume scan
- **Basic restrictions** on the basis of the peak induced *E*-field, peak induced current density, and
- **peak spatial-average SAR** calculated from the Sim4Life simulation.

Since SPEAG release a DASY8 Module WPT system (*SW Module WPT V2.6+*) for E and H-Field measurement, and also the system support Sim4Life plug-in includes the components to import the 3D H-field scan data (*H<sub>x</sub>, H<sub>y</sub>, H<sub>z</sub>* values in the measurement volume) to the Sim4Life simulation platform. And a magneto quasi-static (MQS) simulation is automatically setup to solve for a lossy halfspace Phantom setup. The lossy half-space has muscle tissue dielectric properties ( $\sigma = 0.75 \text{ S/m}$ ,  $\rho = 1000 \text{ kg/m}^3$ ), The induced electric (*E*-) fields and **specific absorption rate (SAR)** are assessed with Sim4Life's Quasi-Static EM Solver (P-EM-QS) using only the measured data.

The post-processing engine determines the maximum induced E-field, current density, and SAR values in a homogeneous half-space of muscle tissue equivalent media (half-space muscle phantom) positioned at the compliance distance. In general, the compliance distance corresponds to the closest point (with respect to the exposure source) the human body (e.g., a part of the hand) can reach during the operation of the source.

The relative dielectric constant, conductivity, and mass density of the homogeneous phantom used in the simulations were 55, 0.75 S/m, and 1000 kg/m<sup>3</sup> respectively, which correspond to the phantom.

- **Simulation Results**

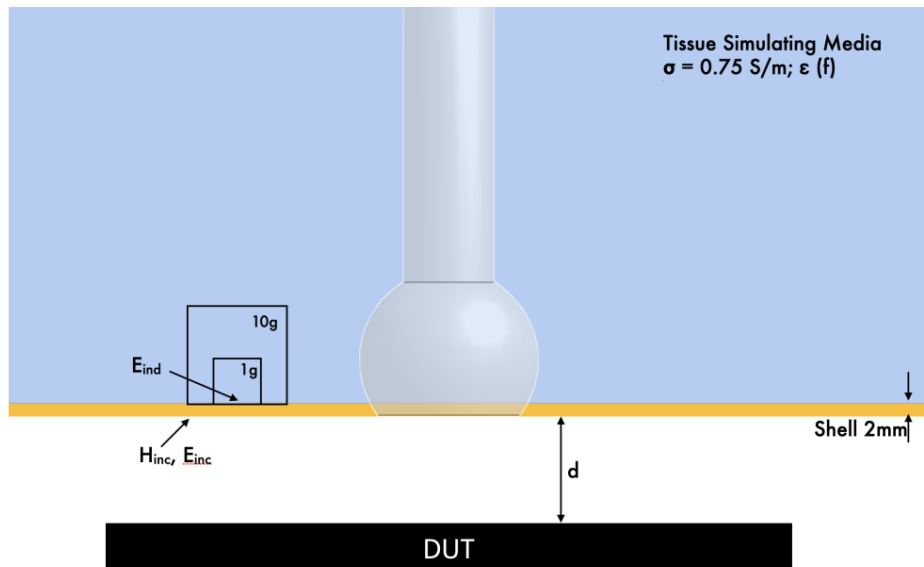

The distance used in the test raw data for simulation and compliance evaluation results is defined as the spacing between the top surface of the DUT and the bottom surface of the fictive phantom shell (with a thickness of 2 mm). In this case, the evaluation is made at distance  $d$ . Typically  $d = 0$ , i.e., at the DUT surface. The evaluation locations of the incident fields (i.e.,  $H_{inc}$  and  $E_{inc}$ ) as well as the induced fields (e.g.,  $E_{ind}$ , psSAR1g, and psSAR10g) are also illustrated.

**The following settings is used in the Dasy8 module WPT v2.6 software:**

1. Total field evaluation: ON
2. Multi-frequency: ON
3. Coverage Factor: ON

**The test plots in appendix B provided by the Dasy8 module WPT software is include the following information:**

1. The field distribution, with a clear illustration of the -20 dB boundary. It is recommended to use the auto extend mode to ensure the full -20 dB boundary is assessed.
2. All three tables produced by the system including the "incident fields, and induced quantities in the standardized phantom and anatomical model", "Standard compliance evaluation, Absolute" and "Standard compliance evaluation, Relative" tables.
3. The test plot(s) shall clearly display the fundamental frequency, amplitude, and all emissions within the frequency range from 3 kHz to 10 MHz.

### 4. Equipment List

Manufacturer	Name of Equipment	Type/Model	Serial Number	Calibration	
				Last Cal.	Due Date
SPEAG	Near-field Electric and Megnetic Field Sensor System	MAGPy-8H3D+E3D	3059	May. 15, 2024	May. 14, 2025
SPEAG	Near-field Electric and Megnetic Field Sensor System	MAGPy-DAS	3064	May. 15, 2024	May. 14, 2025
SPEAG	Calibration Procedure for MAGPy Validation Source	V-Coil350/85	1023	May. 22, 2024	May. 21, 2025

### 5. System Validation

SPEAG developed the evaluation system DASY8 Module WPT for small-to-large size wireless power transfer (WPT) devices that combines subsystems of DASY8, MAGPy, and Sim4Life. The IT'IS Foundation was mandated to develop the system check and validation sources for WPT evaluations.

Below table shows the target value and measured value after normalized to 1A and comparing to the Target value provided by SPEAG calibration, the verification data should be within its specification of 1.24dB.

Test Date	Calibrated Parameters (kHz)	Distance of the Virtual Phantom from the Surface (mm)	Peak H-field (A/m)	Induced peak current density 1cm <sup>2</sup> area avg.(A/m <sup>2</sup> )	Induced peak E-field (V/m)			peak spatial SAR (mW/kg)		
					cube avg.	Local	line avg.	1g avg.	10g avg.	
2024/6/27	85	Target	0	208	2.35	3.35	3.38	3.39	6.5	4.84
			2	189	2.22	3.15	3.18	3.19	5.81	4.38
		Raw Measurement	0	195	2.35	3.34	3.37	3.38	6.5	4.86
			2	178	2.22	3.14	3.17	3.18	5.82	4.42
		Deviation (dB)	0	-0.56	0.00	-0.03	-0.03	-0.03	0.00	0.02
			2	-0.52	0.00	-0.03	-0.03	-0.03	0.01	0.04

## 6. RF Exposure Results

### General Note:

- For WPT evaluation was performed with client with < 15% battery state, equal 50% and > 85% battery state will verify worst configuration found from 15% state.
- Consider the client device in charging and user is using phone, for RF exposure was performed at 0mm separation distance.

### 6.1. Maximum Permissible Exposure Evaluation

#### Electric field Strength Result

Plot No.	Position	Test Distance (mm)	Client Battery State	Measured Einc (V/m)	Einc Limit (V/m)	Result
1	Front	0	< 15%	13.2	614	Pass
	Back	0	< 15%	38.6	614	Pass
	Left Side	0	< 15%	8.44	614	Pass
	Right Side	0	< 15%	9.74	614	Pass
	Top Side	0	< 15%	5.57	614	Pass
	Bottom Side	0	< 15%	6.71	614	Pass
	Back	0	= 50%	34.48	614	Pass
	Back	0	> 85%	36.01	614	Pass
	Flip Front	0	< 15%	21.3	614	Pass
	Flip Back	0	< 15%	35.3	614	Pass
	Flip Left Side	0	< 15%	8.75	614	Pass
	Flip Right Side	0	< 15%	8.14	614	Pass
	Flip Top Side	0	< 15%	8.5	614	Pass
	Flip Bottom Side	0	< 15%	9.1	614	Pass
Flip Back	0	= 50%	30.3	614	Pass	
Flip Back	0	> 85%	31.47	614	Pass	

#### Magnetic field Strength Result

Plot No.	Position	Test Distance (mm)	Client Battery State	Measured Hinc (A/m)	Hinc Limit (A/m)	Result
1	Front	0	< 15%	4.34	1.63	Exceed <sup>(1)</sup>
	Back	0	< 15%	20.2	1.63	Exceed <sup>(1)</sup>
	Left Side	0	< 15%	13.3	1.63	Exceed <sup>(1)</sup>
	Right Side	0	< 15%	11.9	1.63	Exceed <sup>(1)</sup>
	Top Side	0	< 15%	0.109	1.63	Pass
	Bottom Side	0	< 15%	2.55	1.63	Exceed <sup>(1)</sup>
	Back	0	= 50%	19.83	1.63	Exceed <sup>(1)</sup>
	Back	0	> 85%	19.49	1.63	Exceed <sup>(1)</sup>
	Flip Front	0	< 15%	2.14	1.63	Exceed <sup>(1)</sup>
	Flip Back	0	< 15%	19.2	1.63	Exceed <sup>(1)</sup>
	Flip Left Side	0	< 15%	11.4	1.63	Exceed <sup>(1)</sup>
	Flip Right Side	0	< 15%	11.3	1.63	Exceed <sup>(1)</sup>
	Flip Top Side	0	< 15%	3.91	1.63	Exceed <sup>(1)</sup>
	Flip Bottom Side	0	< 15%	2.47	1.63	Exceed <sup>(1)</sup>
Flip Back	0	= 50%	18.98	1.63	Exceed <sup>(1)</sup>	
Flip Back	0	> 85%	18.47	1.63	Exceed <sup>(1)</sup>	

- An assessment against the Limit for peak spatial-average SAR shall be performed for the EUT when the Limits for Maximum Permissible Exposure are exceeded.

**6.2. Peak Spatial-Average SAR Evaluation**

**Peak spatial-average SAR Result**

Plot No.	Position	Test Distance (mm)	Client Battery State	Measured 1g avg. (W/kg)	1g SAR Limit (W/kg)	Result
1	Front	0	< 15%	0.000000677	1.6	Pass
	Back	0	< 15%	0.0000101	1.6	Pass
	Left Side	0	< 15%	0.00000449	1.6	Pass
	Right Side	0	< 15%	0.00000402	1.6	Pass
	Top Side	0	< 15%	0.0000000849	1.6	Pass
	Bottom Side	0	< 15%	0.000000773	1.6	Pass
	Back	0	= 50%	0.00000981	1.6	Pass
	Back	0	> 85%	0.00000916	1.6	Pass
	Flip Front	0	< 15%	0.000000022	1.6	Pass
	Flip Back	0	< 15%	0.00000921	1.6	Pass
	Flip Left Side	0	< 15%	0.000000329	1.6	Pass
	Flip Right Side	0	< 15%	0.000000335	1.6	Pass
	Flip Top Side	0	< 15%	0.0000000892	1.6	Pass
	Flip Bottom Side	0	< 15%	0.0000000718	1.6	Pass
	Flip Back	0	= 50%	0.00000908	1.6	Pass
	Flip Back	0	> 85%	0.00000785	1.6	Pass

**Conclusion:**

Based on SPEAG DASY8 Module WPT-MAGPY system, a magneto quasi-static (MQS) simulation is automatically setup to solve for a lossy halfspace Phantom setup. The lossy half-space has muscle tissue dielectric properties ( $\sigma = 0.75 \text{ S/m}$ ,  $\rho = 1000 \text{ kg/m}^3$ ), The induced electric (E-) fields and specific absorption rate (SAR) are assessed with Sim4Life's Quasi-Static EM Solver (P-EM-QS) that the the product is compliance with Peak spatial-average SAR Result < 1.6W/kg.

## 7. Uncertainty

Uncertainty Budget for Peak Incident H-field					
Error Description	Uncertainty Value (±dB)	Probability	Divisor	(Ci)	Standard Uncertainty (dB)
<b>Measurement System</b>					
Amplitude calibration uncertainty	0.35	N	1	1	0.35
Probe anisotropy	0.60	R	1.732	1	0.35
Probe dynamic linearity	0.20	R	1.732	1	0.12
Probe frequency domain response	0.30	R	1.732	1	0.17
Probe frequency linear interp. fit	0.15	R	1.732	1	0.09
Spatial averaging	0.10	R	1.732	1	0.06
Parasitic E-field sensitivity	0.10	R	1.732	1	0.06
Detection limit	0.15	R	1.732	1	0.09
Readout electronics	0.0	N	1	1	0.0
Probe positioning	0.19	N	1	1	0.19
Repeatability	0.10	N	1	1	0.10
Surface field reconstruction	0.30	N	1	1	0.30
<b>Combined uncertainty ( k = 1)</b>					<b>0.67 dB</b>
<b>Expanded uncertainty ( k = 2)</b>					<b>1.33 dB</b>

Uncertainty Budget for Peak Incident E-field					
Error Description	Uncertainty Value (±dB)	Probability	Divisor	(Ci)	Standard Uncertainty (dB)
<b>Measurement System</b>					
Amplitude calibration uncertainty	0.53	N	1	1	0.53
Probe anisotropy	0.80	R	1.732	1	0.46
Probe dynamic linearity	1.00	R	1.732	1	0.58
Probe frequency domain response	0.30	R	1.732	1	0.17
Probe frequency linear interp. fit	0.15	R	1.732	1	0.09
Parasitic H-field sensitivity	0.20	R	1.732	1	0.12
Detection limit	0.15	R	1.732	1	0.09
Readout electronics	0	N	1	1	0
Repeatability	0.10	N	1	1	0.10
<b>Combined uncertainty ( k = 1)</b>					<b>0.95 dB</b>
<b>Expanded uncertainty ( k = 2)</b>					<b>1.89 dB</b>

DASY8 Uncertainty Budget for psSAR1g according to IEC/IEEE 63184					
Error Description	Uncertainty Value (±%)	Probability	Divisor	(Ci)	Standard Uncertainty (± dB)
<b>Measurement system</b>					
Amplitude calibration uncertainty	0.35	N	1	1	0.35
Probe anisotropy	0.60	R	1.732	1	0.35
Probe dynamic linearity	0.20	R	1.732	1	0.12
Probe frequency domain response	0.30	R	1.732	1	0.17
Probe frequency linear interp. fit	0.15	R	1.732	1	0.09
Spatial averaging	0.10	R	1.732	1	0.06
Parasitic E-field sensitivity	0.10	R	1.732	1	0.06
Detection limit	0.15	R	1.732	1	0.09
Readout electronics	0	N	1	1	0
Probe positioning	0.19	N	1	1	0.19
Repeatability	0.10	N	1	1	0.10
Surface field reconstruction	0.20	N	1	1	0.20
<b>Numerical Simulations</b>					
Grid resolution	0.02	R	1.732	1	0.01
Tissue parameters	0	R	1.732	1	0
Exposure position	0	R	1.732	1	0
Model and exposure location	0.09	N	1.732	1	0.09
Convergence and power budget	0	R	1.732	1	0
Boundary conditions	0.10	R	1.732	1	0.06
Phantom loading/backscattering	0.10	R	1.732	1	0.06
<b>Combined uncertainty ( k = 1 )</b>					<b>0.63 dB</b>
<b>Expanded uncertainty ( k = 2 )</b>					<b>1.27 dB</b>

## **8. Reference**

1. Ilkka Laakso, Valerio De Santis, Silvano Cruciani, Tommaso Campi, and Mauro Feliziani, "Modelling of induced electric fields based on incompletely known magnetic fields", *Physics in Medicine & Biology*, vol. 62, no. 16, pp. 6567, 2017
2. Sami Gabriel, RW Lau, and Camelia Gabriel, "The dielectric properties of biological tissues: li. measurements in the frequency range 10 hz to 20 GHz", *Physics in medicine & biology*, vol. 41, no. 11, pp. 2251, 1996
3. ICNIRP, "Guidelines for limiting exposure to time-varying electric, magnetic and electromagnetic fields (up to 300 GHz)", *Health Physics*, vol. 74, pp. 494–522, 1998.
4. IEEE C95.1, IEEE Standard for Safety Levels with Respect to Human Exposure to Electric, Magnetic, and Electromagnetic Fields, 0 Hz to 300 GHz, IEEE Standards Department, International Committee on Electromagnetic Safety, The Institute of Electrical and Electronics Engineers, Inc. 3 Park Avenue, New York, NY 10016-5997, USA, 2019.
5. International Commission on Non-Ionizing Radiation Protection et al., "Guidelines for limiting exposure to electromagnetic fields (100 kHz to 300 GHz)", *Health Physics*, vol. 118, no. 5, pp. 483– 524, 2020.
6. WR Smythe, "Static and dynamic electricity, 2nd edition", p. 266, 1989.
7. IEC/IEEE 62704-1, Recommended Practice for Determining the Spatial-Peak Specific Absorption Rate (SAR) in the Human Body Due to Wireless Communications Devices, 30 MHz–6 GHz – Part 1: General Requirements for using the Finite Difference Time Domain (FDTD) Method for SAR Calculations, International Electrotechnical Commission (IEC), IEC Technical Committee 106, Geneva, Switzerland, 2017.
8. IEC/IEEE 62704-4, Recommended Practice for Determining the Spatial-Peak Specific Absorption Rate (SAR) in the Human Body Due to Wireless Communications Devices, 30 MHz–6 GHz – Part 1: General Requirements for using the Finite-Element Method (FEM) for SAR Calculations, International Electrotechnical Commission (IEC), IEC Technical Committee 106, Geneva, Switzerland, 2020
9. Assessment methods of the human exposure to electric and magnetic fields from wireless power transfer systems. Models, instrumentation, measurement and numerical methods and procedures (frequency range of 1 kHz to 30 MHz), IEC PAS 63184:2021