

# FCC RF Test Report

APPLICANT : Motorola Mobility LLC  
EQUIPMENT : Mobile Cellular Phone  
BRAND NAME : Motorola  
MODEL NAME : XT2451-1, XT2451-2  
FCC ID : IHDT56AP9  
STANDARD : 47 CFR Part 2, Part 27 Subpart Q  
CLASSIFICATION : PCS Licensed Transmitter Held to Ear (PCE)  
TEST DATE(S) : Mar. 01, 2024 ~ Apr. 02, 2024

We, Sporton International Inc. (ShenZhen), would like to declare that the tested sample has been evaluated in accordance with the procedures given in ANSI C63.26-2015 and shown compliance with the applicable technical standards.

The test results in this report apply exclusively to the tested model / sample. Without written approval of Sporton International Inc. (ShenZhen), the test report shall not be reproduced except in full.

Jason Jia

Approved by: Jason Jia



**Sporton International Inc. (ShenZhen)**

**1/F, 2/F, Bldg 5, Shiling Industrial Zone, Xinwei Village, Xili, Nanshan, Shenzhen, 518055**

**People's Republic of China**



TABLE OF CONTENTS

REVISION HISTORY..... 3
SUMMARY OF TEST RESULT ..... 4
1 GENERAL DESCRIPTION ..... 5
1.1 Applicant ..... 5
1.2 Manufacturer ..... 5
1.3 Product Feature of Equipment Under Test ..... 5
1.4 Product Specification of Equipment Under Test ..... 5
1.5 Modification of EUT ..... 6
1.6 Maximum EIRP Power and Emission Designator ..... 7
1.7 Testing Site ..... 9
1.8 Test Software ..... 9
1.9 Applied Standards ..... 10
1.10 Specification of Accessory ..... 6
2 TEST CONFIGURATION OF EQUIPMENT UNDER TEST ..... 11
2.1 Test Mode ..... 11
2.2 Connection Diagram of Test System ..... 12
2.3 Support Unit used in test configuration and system ..... 12
2.4 Measurement Results Explanation Example ..... 12
2.5 Frequency List of Low/Middle/High Channels ..... 13
3 CONDUCTED TEST ITEMS ..... 14
3.1 Measuring Instruments ..... 14
3.2 Test Setup ..... 14
3.3 Test Result of Conducted Test ..... 14
3.4 Conducted Output Power Measurement ..... 15
3.5 Peak-to-Average Ratio ..... 16
3.6 EIRP ..... 17
3.7 Occupied Bandwidth ..... 18
3.8 Conducted Band Edge Measurement ..... 19
3.9 Conducted Spurious Emission Measurement ..... 20
3.10 Frequency Stability Measurement ..... 21
4 RADIATED TEST ITEMS ..... 22
4.1 Measuring Instruments ..... 22
4.2 Test Setup ..... 22
4.3 Test Result of Radiated Test ..... 23
4.4 Radiated Spurious Emission Measurement ..... 24
5 LIST OF MEASURING EQUIPMENT ..... 25
6 MEASUREMENT UNCERTAINTY ..... 26
APPENDIX A. TEST RESULTS OF CONDUCTED TEST
APPENDIX B. TEST RESULTS OF RADIATED TEST
APPENDIX C. TEST SETUP PHOTOGRAPHS





### SUMMARY OF TEST RESULT

Report Section	FCC Rule	Description	Limit	Result	Remark
3.4	§2.1046	Conducted Output Power	—	Report Only	-
3.5	§27.50 (k)(4)	Peak-to-Average Ratio	<13dB	PASS	
3.6	§27.50 (k)(3)	EIRP	EIRP < 1W (30dBm)	PASS	-
3.7	§2.1049	Occupied Bandwidth	—	Report Only	-
3.8	§2.1051 §27.53 (n)(2)	Conducted Band Edge Measurement	-13dBm/MHz	PASS	-
3.9	§2.1051 §27.53 (n)(2)	Conducted Spurious Emission	-13dBm/MHz	PASS	-
3.10	§2.1055 §27.54	Frequency Stability Temperature & Voltage	Within the band	PASS	-
4.4	§2.1053 §27.53 (n)(2)	Radiated Spurious Emission	-13dBm/MHz	PASS	Under limit 15.61 dB at 9225.00 MHz

**Conformity Assessment Condition:**

1. The test results (PASS/FAIL) with all measurement uncertainty excluded are presented against the regulation limits or in accordance with the requirements stipulated by the applicant/manufacturer who shall bear all the risks of non-compliance that may potentially occur if measurement uncertainty is taken into account.
2. The measurement uncertainty please refer to each test result in the section "Measurement Uncertainty"

**Disclaimer:**

The product specifications of the EUT presented in the test report that may affect the test assessments are declared by the manufacturer who shall take full responsibility for the authenticity.



# 1 General Description

## 1.1 Applicant

Motorola Mobility LLC  
222 W,Merchandise Mart Plaza, Chicago IL 60654 USA

## 1.2 Manufacturer

Motorola Mobility LLC  
222 W,Merchandise Mart Plaza, Chicago IL 60654 USA

## 1.3 Product Feature of Equipment Under Test

Product Feature	
Equipment	Mobile Cellular Phone
Brand Name	Motorola
Model Name	XT2451-1, XT2451-2
FCC ID	IHDT56AP9
IMEI Code	Conducted : 350431590015098/350431590015106 Radiation : 350431590015254/350431590015262
HW Version	DVT2
SW Version	U3UX34.16
EUT Stage	Identical Prototype

Note: The two model names are only for market segment, no other difference.

## 1.4 Product Specification of Equipment Under Test

Product Feature	
Tx/Rx Frequency	5G NR n77: 3450 MHz ~ 3550 MHz 5G NR n78: 3450 MHz ~ 3550 MHz
SCS	30kHz
Bandwidth	n77/n78: 10 / 15 / 20 / 25 / 30 / 40 / 50 / 60 / 70 / 80 / 90 / 100MHz
Antenna Gain	<Ant. 3> 5G NR n77: -2.9 dBi 5G NR n78: -2.9 dBi <Ant. 4> 5G NR n77: -3.7 dBi 5G NR n78: -3.7 dBi <Ant. 6> 5G NR n77: -2.2 dBi 5G NR n78: -2.2 dBi <Ant. 8> 5G NR n77: -4.2 dBi 5G NR n78: -4.2 dBi
Type of Modulation	CP-OFDM: QPSK / 16QAM / 64QAM / 256QAM DFT-s-OFDM: PI/2 BPSK / QPSK / 16QAM / 64QAM / 256QAM

Remark:

1. The maximum EIRP is calculated from max output power and max antenna gain, only the maximum EIRP is shown in the report, 5G NR n77/n78 for Antenna 6.
2. The device supports n77(1T4R) SRS resources on Antenna 3/4/6/8, only the test data of worst Antenna 4 is showed in the report according to the maximum power.
3. 5G NR n77 support UL MIMO mode for Ant(4+8) / Ant(4+6) / Ant(3+8) / Ant(3+6), only the worst test data of Ant(4+8) is shown in the report according to the maximum power and maximum EIRP is calculated from max output power and max antenna gain, Ant(3+6) for 5G NR n77/n78.
4. The device supports HPUE(PC2) for 5G NR n77/n78 SISO mode, HPUE(PC2) for 5G NR n78 MIMO mode, and HPUE(PC1.5) for n77 MIMO mode.
5. 5G NR n78 UL\_MIMO mode only supports CP-OFDM Modulation, 5G NR n77/n78 the MIMO mode is completely uncorrelated, so the directional gain is selected the maximum gain among all antennas.
6. For UL MIMO mode, the conducted BE/Spurious are tested at single antenna port and add  $10 \cdot \log(N_{ANT})$  according to KDB 662911 D01.
7. 5G NR n77/n78 support SA and NSA mode. The whole testing has assessed SA mode for n77 by referring to the higher conducted power for conducted test items.
8. All the supported EN-DC combinations are verified conducted power, only the EN-DC combination with highest power are shown in the report.
9. The EN-DC mode combination could be referred to the product spec.
10. The device supports main PA for SA mode and other PA for NSA mode, the maximum EIRP is shown and other PA for Ant(8+2) are shown in the report.

## 1.5 Modification of EUT

No modifications are made to the EUT during all test items.

## 1.6 Specification of Accessory

Accessories Information			
Battery 1	Brand Name	Motorola(ATL)	Model Name QR10
Battery 2	Brand Name	Motorola(ATL)	Model Name QR30
USB Cable 1	Brand Name	Motorola(SAIBAO)	Model Name SC18D86731
USB Cable 2	Brand Name	Motorola(Luxshare)	Model Name SC18E08103

## 1.7 Maximum EIRP Power and Emission Designator

5G NR n77 SA		PI/2 BPSK / QPSK		16QAM/64QAM/256QAM	
BW (MHz)	Frequency Range (MHz)	Maximum EIRP(W)	Emission Designator (99%OBW)	Maximum EIRP(W)	Emission Designator (99%OBW)
10	3455.01 ~ 3544.98	0.1722	8M58G7D	0.1216	8M59W7D
15	3457.50 ~ 3542.49	0.1770	13M6G7D	0.1211	13M6W7D
20	3460.02 ~ 3540.00	0.1750	18M2G7D	0.1194	18M2W7D
25	3462.51 ~ 3537.48	0.1832	23M2G7D	0.1222	23M3W7D
30	3465.00 ~ 3534.99	0.1795	27M9G7D	0.1236	27M9W7D
40	3470.01 ~ 3529.98	0.1746	37M8G7D	0.1213	38M1W7D
50	3475.02 ~ 3525.00	0.1811	47M6G7D	0.1259	47M7W7D
60	3480.00 ~ 3519.99	0.1762	58M0G7D	0.1191	57M9W7D
70	3485.01 ~ 3514.98	0.1714	67M5G7D	0.1211	67M6W7D
80	3490.02 ~ 3510.00	0.1766	77M5G7D	0.1225	77M6W7D
90	3495.00 ~ 3504.99	0.1803	87M5G7D	0.1236	87M7W7D
100	3500.01	0.1849	97M4G7D	0.1303	97M5W7D

5G NR n78 SA		PI/2 BPSK / QPSK		16QAM/64QAM/256QAM	
BW (MHz)	Frequency Range (MHz)	Maximum EIRP(W)	Emission Designator (99%OBW)	Maximum EIRP(W)	Emission Designator (99%OBW)
10	3455.01 ~ 3544.98	0.1687	8M58G7D	0.1038	8M59W7D
15	3457.50 ~ 3542.49	0.1648	13M6G7D	0.1028	13M6W7D
20	3460.02 ~ 3540.00	0.1675	18M2G7D	0.1052	18M2W7D
25	3462.51 ~ 3537.48	0.1734	23M2G7D	0.1069	23M3W7D
30	3465.00 ~ 3534.99	0.1675	27M9G7D	0.1052	27M9W7D
40	3470.01 ~ 3529.98	0.1648	37M8G7D	0.1067	38M1W7D
50	3475.02 ~ 3525.00	0.1633	47M6G7D	0.1069	47M7W7D
60	3480.00 ~ 3519.99	0.1656	58M0G7D	0.1030	57M9W7D
70	3485.01 ~ 3514.98	0.1644	67M5G7D	0.1047	67M6W7D
80	3490.02 ~ 3510.00	0.1710	77M5G7D	0.1079	77M6W7D
90	3495.00 ~ 3504.99	0.1675	87M5G7D	0.1086	87M7W7D
100	3500.01	0.1766	97M4G7D	0.1099	97M5W7D



5G NR n77 UL MIMO		PI/2 BPSK / QPSK		16QAM/64QAM/256QAM	
BW (MHz)	Frequency Range (MHz)	Maximum EIRP(W)	Emission Designator (99%OBW)	Maximum EIRP(W)	Emission Designator (99%OBW)
10	3455.01 ~ 3544.98	0.3076	8M57G7D	0.2421	8M59W7D
15	3457.50 ~ 3542.49	0.3097	13M6G7D	0.2366	13M6W7D
20	3460.02 ~ 3540.00	0.3083	18M2G7D	0.2355	18M3W7D
25	3462.51 ~ 3537.48	0.3177	23M2G7D	0.2399	23M2W7D
30	3465.00 ~ 3534.99	0.3155	27M9G7D	0.2421	27M9W7D
40	3470.01 ~ 3529.98	0.3105	37M8G7D	0.2455	37M9W7D
50	3475.02 ~ 3525.00	0.3258	47M7G7D	0.2594	47M6W7D
60	3480.00 ~ 3519.99	0.3119	57M8G7D	0.2489	57M9W7D
70	3485.01 ~ 3514.98	0.3090	67M5G7D	0.2455	67M6W7D
80	3490.02 ~ 3510.00	0.3251	77M7G7D	0.2523	77M6W7D
90	3495.00 ~ 3504.99	0.3281	87M5G7D	0.2518	87M6W7D
100	3500.01	0.3459	97M5G7D	0.2518	97M6W7D

5G NR n78 UL MIMO		QPSK		16QAM/64QAM/256QAM	
BW (MHz)	Frequency Range (MHz)	Maximum EIRP(W)	Emission Designator (99%OBW)	Maximum EIRP(W)	Emission Designator (99%OBW)
10	3455.01 ~ 3544.98	0.1242	8M57G7D	0.1012	8M59W7D
15	3457.50 ~ 3542.49	0.1239	13M6G7D	0.1054	13M6W7D
20	3460.02 ~ 3540.00	0.1250	18M2G7D	0.1138	18M3W7D
25	3462.51 ~ 3537.48	0.1239	23M2G7D	0.1067	23M2W7D
30	3465.00 ~ 3534.99	0.1245	27M9G7D	0.1072	27M9W7D
40	3470.01 ~ 3529.98	0.1222	37M8G7D	0.1009	37M9W7D
50	3475.02 ~ 3525.00	0.1253	47M7G7D	0.1084	47M6W7D
60	3480.00 ~ 3519.99	0.1222	57M8G7D	0.1112	57M9W7D
70	3485.01 ~ 3514.98	0.1236	67M5G7D	0.1059	67M6W7D
80	3490.02 ~ 3510.00	0.1242	77M7G7D	0.1146	77M6W7D
90	3495.00 ~ 3504.99	0.1274	87M5G7D	0.1114	87M6W7D
100	3500.01	0.1330	97M5G7D	0.1107	97M6W7D

**Note:**

- 5G NR Band n77 overlaps the entire frequency range of Band n78, and n77 power > n78 power, therefore the conducted test results of n78 provided in this report cover n77.
- All modulations have been tested, and only the worst test results of PSK & QAM are shown in the report.

### 1.8 Testing Site

Sporton International Inc. (ShenZhen) is accredited to ISO/IEC 17025:2017 by American Association for Laboratory Accreditation with Certificate Number 5145.01.

<b>Test Firm</b>	Sporton International Inc. (ShenZhen)		
<b>Test Site Location</b>	1/F, 2/F, Bldg 5, Shiling Industrial Zone, Xinwei Village, Xili, Nanshan, Shenzhen, 518055 People's Republic of China TEL: +86-755-86379589 FAX: +86-755-86379595		
<b>Test Site No.</b>	<b>Sporton Site No.</b>	<b>FCC Designation No.</b>	<b>FCC Test Firm Registration No.</b>
	TH01-SZ	CN1256	421272

<b>Test Firm</b>	Sporton International Inc. (ShenZhen)		
<b>Test Site Location</b>	101, 1st Floor, Block B, Building 1, No. 2, Tengfeng 4th Road, Fenghuang Community, Fuyong Street, Baoan District, Shenzhen City, Guangdong Province 518103 People's Republic of China TEL: +86-755-86066985		
<b>Test Site No.</b>	<b>Sporton Site No.</b>	<b>FCC Designation No.</b>	<b>FCC Test Firm Registration No.</b>
	03CH04-SZ	CN1256	421272

### 1.9 Test Software

Item	Site	Manufacture	Name	Version
1.	03CH04-SZ	AUDIX	E3	6.2009-8-24



## 1.10 Applied Standards

According to the specifications of the manufacturer, the EUT must comply with the requirements of the following standards:

- ♦ 47 CFR Part 2, Part 27 Subpart Q
- ♦ ANSI C63.26-2015
- ♦ FCC KDB 971168 Power Meas License Digital Systems D01 v03r01
- ♦ FCC KDB 412172 D01 Determining ERP and EIRP v01r01

### **Remark:**

1. All test items were verified and recorded according to the standards and without any deviation during the test.
2. This EUT has also been tested and complied with the requirements of FCC Part 15, Subpart B, recorded in a separate test report.

## 2 Test Configuration of Equipment Under Test

### 2.1 Test Mode

Antenna port conducted and radiated test items listed below are performed according to KDB 971168 D01 Power Meas. License Digital Systems v03r01 with maximum output power.

The EUT is a folding phone, pretest the open status and closed status, only the worst status perform final test and record in the report.

For the accessories, pretest standalone mode / Earphone mode / Adapter mode / Wireless charging mode, only the worst status perform final test and record in the report.

Radiated measurements are performed by rotating the EUT in three different orthogonal test planes to find the maximum emission. (Y-Plane)

Test Cases	Band	Bandwidth (MHz)	Modulation	RB #	Test Channel
		eg. 5M, 10M, 15M, 20M	eg. PI/2 BPSK, QPSK, 16QAM, 64QAM, 256QAM	1RB, Partial RB, Full RB	L/M/H
Max. Output Power	5G n77	10M, 15M, 20M, 25M, 30M, 40M, 50M, 60M, 70M, 80M, 90M, 100M	All Modulations	1RB, Full RB	L, M, H
	5G n78	10M, 15M, 20M, 25M, 30M, 40M, 50M, 60M, 70M, 80M, 90M, 100M	All Modulations	1RB, Full RB	L, M, H
Peak-to-Average Ratio	5G n77	20M	PI/2 BPSK, QPSK	Full RB	M
E.I.R.P	5G n77	10M, 15M, 20M, 25M, 30M, 40M, 50M, 60M, 70M, 80M, 90M, 100M	All Modulations	1RB, Full RB	L, M, H
	5G n78	10M, 15M, 20M, 25M, 30M, 40M, 50M, 60M, 70M, 80M, 90M, 100M	All Modulations	1RB, Full RB	L, M, H
26dB and 99% Bandwidth	5G n77	10M, 15M, 20M, 25M, 30M, 40M, 50M, 60M, 70M, 80M, 90M, 100M	QPSK, 16QAM, 64QAM, 256QAM	Full RB	M
Conducted Band Edge	5G n77	10M, 50M, 100M	PI/2 BPSK, QPSK	1RB, Full RB	L, H
Conducted Spurious Emission	5G n77	10M, 50M, 100M	PI/2 BPSK, QPSK	1RB	L, M, H
Frequency Stability	5G n77	20M	QPSK	Full RB	M
Radiated Spurious Emission	5G n77	Worst case from maximum power			M

**Note:**

- The device is investigated from 30MHz to 10 times of fundamental signal for radiated spurious emission test under different RB size/offset and modulations in exploratory test. Subsequently, only the worst case emissions are reported.
- Frequency Stability: Normal Voltage = 3.88V ; Low Voltage =3.4V.; High Voltage =4.53V.

## 2.2 Connection Diagram of Test System

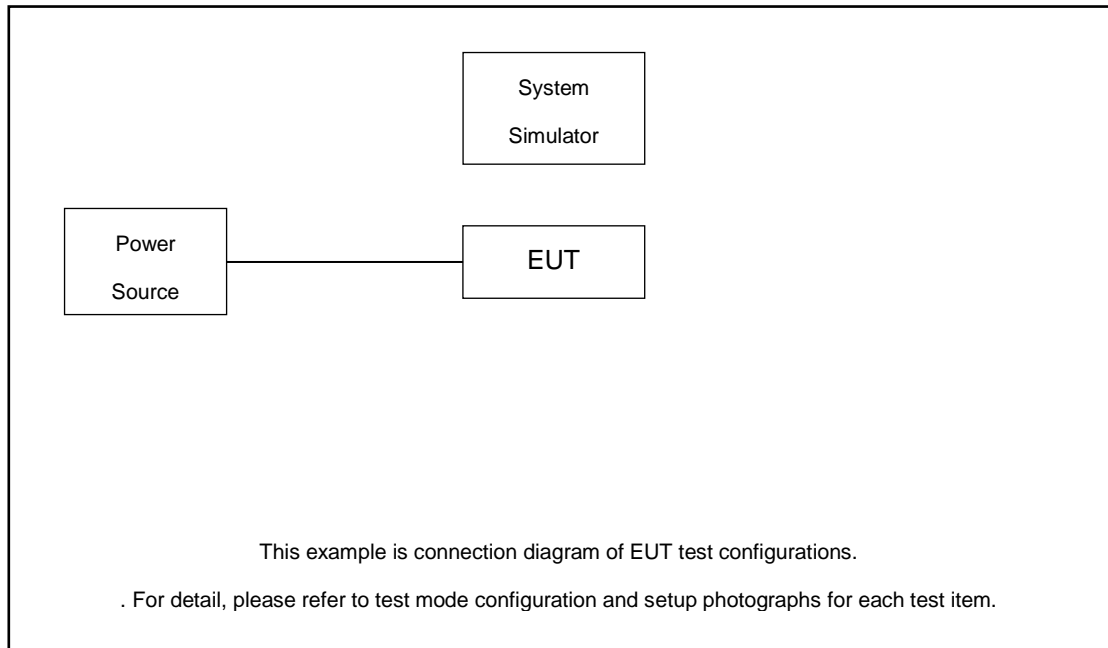

## 2.3 Support Unit used in test configuration and system

Item	Equipment	Trade Name	Model No.	FCC ID	Data Cable	Power Cord
1.	Power Supply	GWINSTEK	PSS-2002	N/A	N/A	Unshielded, 1.8 m
2.	LTE Base Station	Anritsu	MT8820C	N/A	N/A	Unshielded, 1.8 m
3.	NR Base Station	Anritsu	MT8000A	N/A	N/A	Unshielded, 1.8 m

## 2.4 Measurement Results Explanation Example

### For all conducted test items:

The offset level is set in the spectrum analyzer to compensate the RF cable loss between EUT conducted output port and spectrum analyzer. With the offset compensation, the spectrum analyzer reading level is exactly the EUT RF output level.

The spectrum analyzer offset is derived from RF cable loss.

$Offset = RF\ cable\ loss$  .

Following shows an offset computation example with cable loss 8.9 dB.

Example :

$Offset(dB) = RF\ cable\ loss(dB)$ .  
 $= 8.9\ (dB)$

## 2.5 Frequency List of Low/Middle/High Channels

5G n77/n78 Channel and Frequency List				
BW [MHz]	Channel/Frequency(MHz)	Lowest	Middle	Highest
100	Channel	-	633334	-
	Frequency	-	3500.01	-
90	Channel	633000	633334	633666
	Frequency	3495	3500.01	3504.99
80	Channel	632668	633334	634000
	Frequency	3490.02	3500.01	3510
70	Channel	632334	633334	634332
	Frequency	3485.01	3500.01	3514.98
60	Channel	632000	633334	634666
	Frequency	3480	3500.01	3519.99
50	Channel	631668	633334	635000
	Frequency	3475.02	3500.01	3525
40	Channel	631334	633334	635332
	Frequency	3470.01	3500.01	3529.98
30	Channel	631000	633334	635666
	Frequency	3465	3500.01	3534.99
25	Channel	630834	633334	635832
	Frequency	3462.51	3500.01	3537.48
20	Channel	630668	633334	636000
	Frequency	3460.02	3500.01	3540
15	Channel	630500	633334	636166
	Frequency	3457.5	3500.01	3542.49
10	Channel	630334	633334	636332
	Frequency	3455.01	3500.01	3544.98

### 3 Conducted Test Items

#### 3.1 Measuring Instruments

See list of measuring instruments of this test report.

#### 3.2 Test Setup

##### 3.2.1 Conducted Output Power

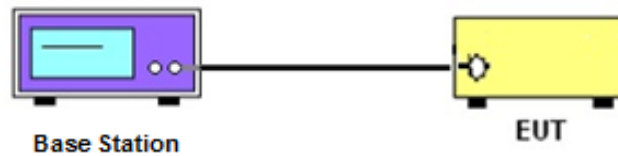

##### 3.2.2 Peak-to-Average Ratio, Occupied / 26dB Bandwidth, Band-Edge and Conducted Spurious Emission

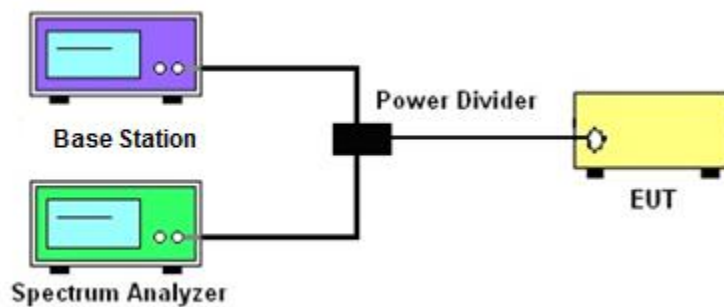

##### 3.2.3 Frequency Stability

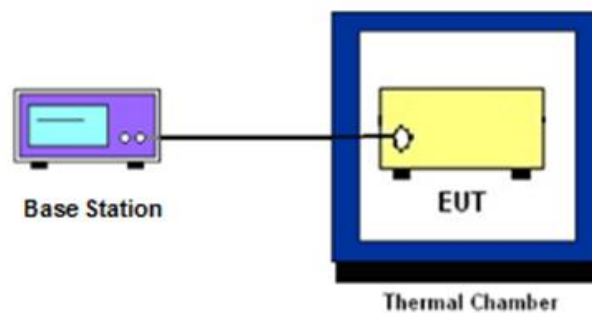

### 3.3 Test Result of Conducted Test

Please refer to Appendix A.



## **3.4 Conducted Output Power Measurement**

### **3.4.1 Description of the Conducted Output Power Measurement**

A base station simulator was used to establish communication with the EUT. Its parameters were set to transmit the maximum power on the EUT. The measured power in the radio frequency on the transmitter output terminals shall be reported.

### **3.4.2 Test Procedures**

1. The testing follows ANSI C63.26 Section 5.2
2. The transmitter output port was connected to the system simulator.
3. Set EUT at maximum power through the system simulator.
4. Select lowest, middle, and highest channels for each band and different modulation.
5. Measure and record the power level from the system simulator.

## 3.5 Peak-to-Average Ratio

### 3.5.1 Description of the PAR Measurement

Power Complementary Cumulative Distribution Function (CCDF) curves provide a means for characterizing the power peaks of a digitally modulated signal on a statistical basis. A CCDF curve depicts the probability of the peak signal amplitude exceeding the average power level. Most contemporary measurement instrumentation include the capability to produce CCDF curves for an input signal provided that the instrument's resolution bandwidth can be set wide enough to accommodate the entire input signal bandwidth. In measuring transmissions in this band using an average power technique, the peak-to-average ratio (PAR) of the transmission may not exceed 13 dB.

### 3.5.2 Test Procedures

1. The testing follows ANSI C63.26 Section 5.2.3.4 (CCDF).
2. The EUT was connected to spectrum and system simulator via a power divider.
3. Set the CCDF (Complementary Cumulative Distribution Function) option in spectrum analyzer.
4. The highest RF powers were measured and recorded the maximum PAPR level associated with a probability of 0.1 %.
5. Record the deviation as Peak to Average Ratio.

## 3.6 EIRP

### 3.6.1 Description of EIRP Limit

#### § 27.50 (k)(3)

Mobile devices are limited to 1Watt (30 dBm) EIRP. Mobile devices operating in these bands must employ a means for limiting power to the minimum necessary for successful communications

### 3.6.2 Test Procedures

1. According to KDB 412172 D01 Power Approach,
2.  $EIRP = P_T + G_T - L_C$ ,  $ERP = EIRP - 2.15$ , where  
 $P_T$  = transmitter output power in dBm  
 $G_T$  = gain of the transmitting antenna in dBi  
 $L_C$  = signal attenuation in the connecting cable between the transmitter and antenna in dB



## 3.7 Occupied Bandwidth

### 3.7.1 Description of Occupied Bandwidth Measurement

The occupied bandwidth is the width of a frequency band such that, below the lower and above the upper frequency limits, the mean powers emitted are each equal to a specified percentage 0.5% of the total mean transmitted power.

The 26 dB emission bandwidth is defined as the frequency range between two points, one above and one below the carrier frequency, at which the spectral density of the emission is attenuated 26 dB below the maximum in-band spectral density of the modulated signal. Spectral density (power per unit bandwidth) is to be measured with a detector of resolution bandwidth equal to approximately 1.0% of the emission bandwidth.

### 3.7.2 Test Procedures

1. The testing follows ANSI C63.26 Section 5.4
2. The EUT was connected to spectrum analyzer and system simulator via a power divider.
3. The spectrum analyzer center frequency is set to the nominal EUT channel center frequency. The span range for the spectrum analyzer shall be between two and five times the anticipated OBW.
4. The nominal resolution bandwidth (RBW) shall be in the range of 1 to 5 % of the anticipated OBW, and the VBW shall be at least 3 times the RBW.
5. Set the detection mode to peak, and the trace mode to max hold.
6. Determine the reference value: Set the EUT to transmit a modulated signal. Allow the trace to stabilize. Set the spectrum analyzer marker to the highest level of the displayed trace.  
(this is the reference value)
7. Determine the “-26 dB down amplitude” as equal to (Reference Value – X).
8. Place two markers, one at the lowest and the other at the highest frequency of the envelope of the spectral display such that each marker is at or slightly below the “-X dB down amplitude” determined in step 6. If a marker is below this “-X dB down amplitude” value it shall be placed as close as possible to this value. The OBW is the positive frequency difference between the two markers.
9. Use the 99 % power bandwidth function of the spectrum analyzer and report the measured bandwidth.

## 3.8 Conducted Band Edge Measurement

### 3.8.1 Description of Conducted Band Edge Measurement

#### § 27.53 (n)(2)

For mobile operations in the 3450-3550 MHz band, the conducted power of any emission outside the licensee's authorized bandwidth shall not exceed  $-13$  dBm/MHz.

Compliance with this paragraph is based on the use of measurement instrumentation employing a resolution bandwidth of 1 megahertz or greater. However, in the 1 megahertz bands immediately outside and adjacent to the licensee's frequency block, a resolution bandwidth of at least one percent of the emission bandwidth of the fundamental emission of the transmitter may be employed, but limited to a maximum of 200 kHz. In the bands between 1 and 5 MHz removed from the licensee's frequency block, the minimum resolution bandwidth for the measurement shall be 500 kHz.

### 3.8.2 Test Procedures

1. The testing follows ANSI C63.26 section 5.7
2. The EUT was connected to spectrum analyzer and system simulator via a power divider.
3. The band edges of low and high channels for the highest RF powers were measured.
4. Set RBW  $\geq 1\%$  EBW but limited to a maximum of 200 kHz in the 1MHz band immediately outside and adjacent to the band edge.
5. Beyond the 1 MHz and 5 MHz removed from the band edge, set RBW  $\geq 500$ KHz.
6. Beyond the 5 MHz removed from the band edge, set RBW = 1MHz.
7. Set spectrum analyzer with RMS detector.
8. The RF fundamental frequency should be excluded against the limit line in the operating frequency band.
9. Checked that all the results comply with the emission limit line.

## 3.9 Conducted Spurious Emission Measurement

### 3.9.1 Description of Conducted Spurious Emission Measurement

The power of any emission outside of the authorized operating frequency ranges shall not exceed -13 dBm/MHz.

It is measured by means of a calibrated spectrum analyzer and scanned from 30MHz up to a frequency including its 10<sup>th</sup> harmonic.

### 3.9.2 Test Procedures

1. The testing follows ANSI C63.26 section 5.7
2. The EUT was connected to spectrum analyzer and system simulator via a power divider.
3. The RF output of EUT was connected to the spectrum analyzer by RF cable and attenuator. The path loss was compensated to the results for each measurement.
4. The middle channel for the highest RF power within the transmitting frequency was measured.
5. The conducted spurious emission for the whole frequency range was taken.
6. Make the measurement with the spectrum analyzer's RBW = 1MHz, VBW = 3MHz.
7. Set spectrum analyzer with RMS detector.
8. Taking the record of maximum spurious emission.
9. The RF fundamental frequency should be excluded against the limit line in the operating frequency band.
10. Checked that all the results comply with the emission limit line.

## 3.10 Frequency Stability Measurement

### 3.10.1 Description of Frequency Stability Measurement

The frequency stability shall be measured by variation of ambient temperature and variation of primary supply voltage to ensure that the fundamental emission stays within the authorized frequency block.

### 3.10.2 Test Procedures for Temperature Variation

1. The testing follows ANSI C63.26 section 5.6.4
2. The EUT was set up in the thermal chamber and connected with the system simulator.
3. With power OFF, the temperature was decreased to  $-30^{\circ}\text{C}$  and the EUT was stabilized before testing. Power was applied and the maximum change in frequency was recorded within one minute.
4. With power OFF, the temperature was raised in  $10^{\circ}\text{C}$  step up to  $50^{\circ}\text{C}$ . The EUT was stabilized at each step for at least half an hour. Power was applied and the maximum frequency change was recorded within one minute.

### 3.10.3 Test Procedures for Voltage Variation

1. The testing follows ANSI C63.26 section 5.6.5.
2. The EUT was placed in a temperature chamber at  $20\pm 5^{\circ}\text{C}$  and connected with the system simulator.
3. The power supply voltage to the EUT was varied from 85% to 115% of the nominal value for other than hand carried battery equipment.
4. For hand carried, battery powered equipment, reduce the primary ac or dc supply voltage to the battery operating end point, which shall be specified by the manufacturer.
5. The variation in frequency was measured for the worst case.

## 4 Radiated Test Items

### 4.1 Measuring Instruments

See list of measuring instruments of this test report.

### 4.2 Test Setup

#### 4.2.1 For radiated test below 30MHz

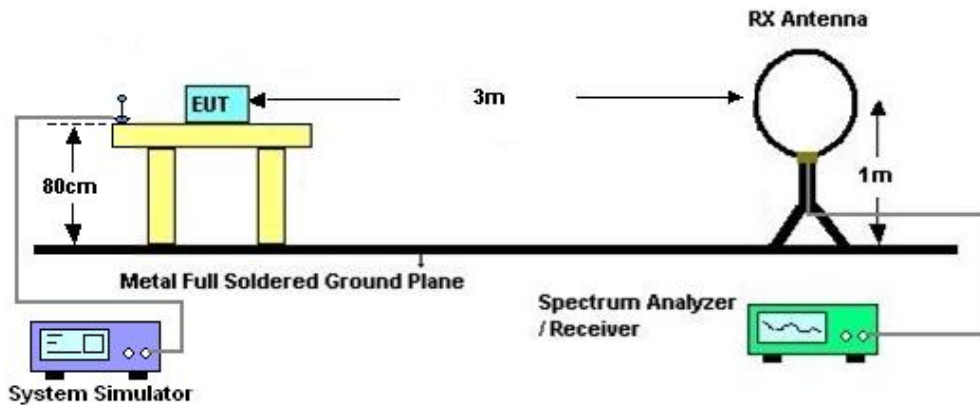

#### 4.2.2 For radiated test from 30MHz to 1GHz

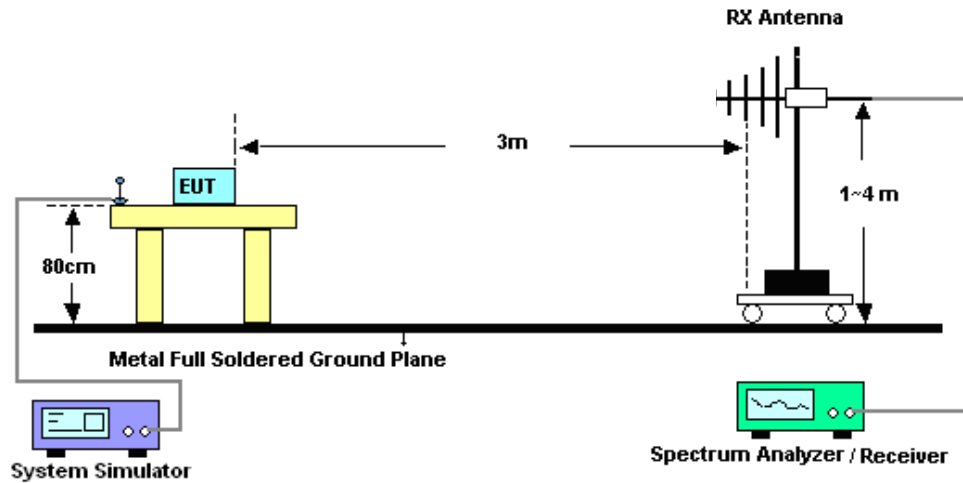

### 4.2.3 For radiated test above 1GHz

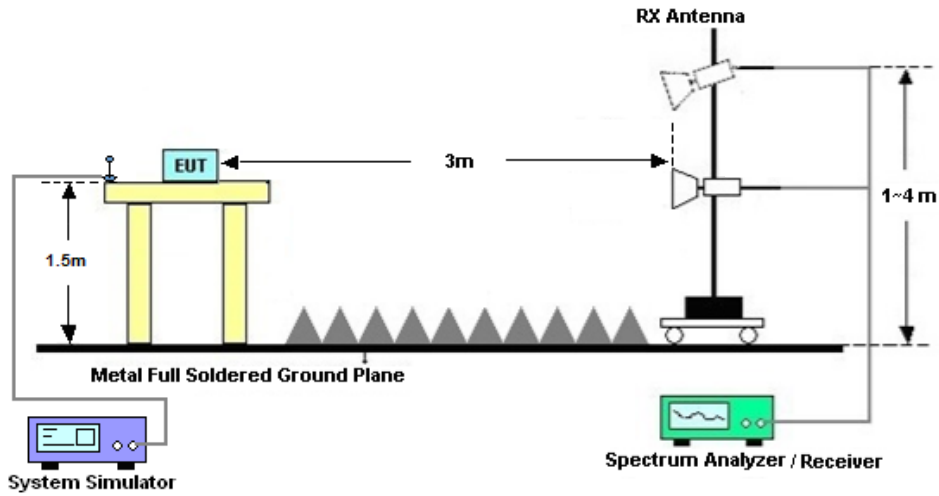

### 4.3 Test Result of Radiated Test

The low frequency, which started from 9 kHz to 30MHz, was pre-scanned and the result which was 20dB lower than the limit line was not reported.

Please refer to Appendix B.

## 4.4 Radiated Spurious Emission Measurement

### 4.4.1 Description of Radiated Spurious Emission

The radiated spurious emission was measured by substitution method according to ANSI C63.26. The power of any emission outside of the authorized operating frequency ranges shall not exceed -13 dBm/MHz.

The spectrum is scanned from 30 MHz up to a frequency including its 10th harmonic.

### 4.4.2 Test Procedures

1. The testing follows ANSI C63.26 Section 5.5
2. The EUT was placed on a turntable with 0.8 meter height for frequency below 1GHz and 1.5 meter height for frequency above 1GHz respectively above ground.
3. The EUT was set 3 meters from the receiving antenna mounted on the antenna tower.
4. The table was rotated 360 degrees to determine the position of the highest spurious emission.
5. The height of the receiving antenna is varied between 1m to 4m to search the maximum spurious emission for both horizontal and vertical polarizations.
6. During the measurement, the system simulator parameters were set to force the EUT transmitting at maximum output power.
7. Make the measurement with the spectrum analyzer's RBW = 1MHz, VBW = 3MHz, taking the record of maximum spurious emission.
8. A horn antenna was substituted in place of the EUT and was driven by a signal generator.
9. Tune the output power of signal generator to the same emission level with EUT maximum spurious emission.  
$$\text{EIRP (dBm)} = \text{S.G. Power} - \text{Tx Cable Loss} + \text{Tx Antenna Gain}$$
$$\text{ERP (dBm)} = \text{EIRP} - 2.15$$
10. The RF fundamental frequency should be excluded against the limit line in the operating frequency band.



## 5 List of Measuring Equipment

Instrument	Manufacturer	Model No.	Serial No.	Characteristics	Calibration Date	Test Date	Due Date	Remark
EXA Spectrum Analyzer	KEYSIGHT	N9010A	MY55150213	10Hz~44GHz	Jul. 07, 2023	Mar. 01, 2024~ Mar. 21, 2024	Jul. 06, 2024	Conducted (TH01-SZ)
Power Divider	TOJOIN	PS-2SM-04 265	60.06.020.0077	0.4GHz~26.5GHz	Dec. 25, 2023	Mar. 01, 2024~ Mar. 21, 2024	Dec. 24, 2024	Conducted (TH01-SZ)
Thermal Chamber	Ten Billion Hongzhangroup	LP-150U	H2014081803	-40~+150°C	Jul. 05, 2023	Mar. 01, 2024~ Mar. 21, 2024	Jul. 04, 2024	Conducted (TH01-SZ)
EMI Test Receiver	R&S	ESR7	101404	9kHz~7GHz	Oct. 18, 2023	Mar. 29, 2024~ Apr. 02, 2024	Oct. 17, 2024	Radiation (03CH04-SZ)
EXA Spectrum Analyzer	KEYSIGHT	N9010A	MY55150213	10Hz~44GHz	Jul. 07, 2023	Mar. 29, 2024~ Apr. 02, 2024	Jul. 06, 2024	Radiation (03CH04-SZ)
Loop Antenna	R&S	HFH2-Z2	100354	9kHz~30MHz	Jun. 28, 2022	Mar. 29, 2024~ Apr. 02, 2024	Jun. 27, 2024	Radiation (03CH04-SZ)
Bilog Antenna	TeseQ	CBL6111D	41909	30MHz~1GHz	May 14, 2023	Mar. 29, 2024~ Apr. 02, 2024	May 13, 2024	Radiation (03CH04-SZ)
Double Ridge Horn Antenna	SCHWARZBECK	BBHA9120D	9120D-1474	1GHz~18GHz	Jul. 07, 2023	Mar. 29, 2024~ Apr. 02, 2024	Jul. 06, 2024	Radiation (03CH04-SZ)
Horn Antenna	SCHWARZBECK	BBHA9170	9170#679	15GHz~40GHz	Jul. 08, 2023	Mar. 29, 2024~ Apr. 02, 2024	Jul. 07, 2024	Radiation (03CH04-SZ)
Amplifier	Burgeon	BPA-530	102211	0.01Hz ~3000MHz	Oct. 18, 2023	Mar. 29, 2024~ Apr. 02, 2024	Oct. 17, 2024	Radiation (03CH04-SZ)
HF Amplifier	MITEQ	AMF-7D-00 101800-30-1 0P-R	1943528	1GHz~18GHz	Oct. 18, 2023	Mar. 29, 2024~ Apr. 02, 2024	Oct. 17, 2024	Radiation (03CH04-SZ)
HF Amplifier	MITEQ	TTA1840-35 -HG	1871923	18GHz~40GHz	Jul. 07, 2023	Mar. 29, 2024~ Apr. 02, 2024	Jul. 06, 2024	Radiation (03CH04-SZ)
Amplifier	Agilent Technologies	83017A	MY57280136	500MHz~26.5GHz	Aug. 21, 2023	Mar. 29, 2024~ Apr. 02, 2024	Aug. 20, 2024	Radiation (03CH04-SZ)
AC Power Source	APC	AFV-S-600B	F119050019	N/A	Oct. 18, 2023	Mar. 29, 2024~ Apr. 02, 2024	Oct. 17, 2024	Radiation (03CH04-SZ)
Turn Table	EM	EM1000	N/A	0~360 degree	NCR	Mar. 29, 2024~ Apr. 02, 2024	NCR	Radiation (03CH04-SZ)
Antenna Mast	EM	EM1000	N/A	1 m~4 m	NCR	Mar. 29, 2024~ Apr. 02, 2024	NCR	Radiation (03CH04-SZ)

NCR: No Calibration Required

## 6 Measurement Uncertainty

The measurement uncertainties shown below were calculated in accordance with the requirements of ANSI 63.26-2015. All the measurement uncertainty value were shown with a coverage K=2 to indicate 95% level of confidence. The measurement data show herein meets or exceeds the CISPR measurement uncertainty values specified in CISPR 16-4-2 and can be compared directly to specified limit to determine compliance.

### Uncertainty of Conducted Measurement

Test Item	Uncertainty
Conducted Spurious Emission & Bandedge	±1.34 dB
Occupied Channel Bandwidth	±0.012 MHz
Conducted Power	±1.34 dB
Peak to Average Ratio	±1.34 dB
Frequency Stability	±1.3 Hz

### Uncertainty of Radiated Emission Measurement (30 MHz ~ 1000 MHz)

Measuring Uncertainty for a Level of Confidence of 95% (U = 2Uc(y))	2.8 dB
---	--------

### Uncertainty of Radiated Emission Measurement (1 GHz ~ 18 GHz)

Measuring Uncertainty for a Level of Confidence of 95% (U = 2Uc(y))	3.1 dB
---	--------

### Uncertainty of Radiated Emission Measurement (18 GHz ~ 40 GHz)

Measuring Uncertainty for a Level of Confidence of 95% (U = 2Uc(y))	3.9 dB
---	--------

----- THE END -----



## Appendix A. Test Results of Conducted Test

Test Engineer :	Khan Zhen	Temperature :	22~23°C
		Relative Humidity :	40~42%

# FR1 N77

## Transmitter Conducted Output Power And EIRP, (G<sub>T</sub> - L<sub>C</sub>)= -2.2 dB

NR Band	SCS (kHz)	Bandwidth (MHz)	Arfcn	Freq (MHz)	Modulation	RB	Conducted Power(dBm)	EIRP (dBm)	EIRP (W)
77	30	10	630334	3455.01	DFT-s-OFDM QPSK	1@1	24.53	22.33	0.1710
77	30	10	630334	3455.01	DFT-s-OFDM 16 QAM	1@1	22.54	20.34	0.1081
77	30	10	633334	3500.01	DFT-s-OFDM QPSK	1@1	24.37	22.17	0.1648
77	30	10	633334	3500.01	DFT-s-OFDM 16 QAM	1@1	22.32	20.12	0.1028
77	30	10	636332	3544.98	DFT-s-OFDM QPSK	1@1	24.56	22.36	0.1722
77	30	10	636332	3544.98	DFT-s-OFDM 16 QAM	1@1	22.54	20.34	0.1081
77	30	15	630500	3457.5	DFT-s-OFDM QPSK	1@1	24.68	22.48	0.1770
77	30	15	630500	3457.5	DFT-s-OFDM 16 QAM	1@1	22.74	20.54	0.1132
77	30	15	633334	3500.01	DFT-s-OFDM QPSK	1@1	24.38	22.18	0.1652
77	30	15	633334	3500.01	DFT-s-OFDM 16 QAM	1@1	22.37	20.17	0.1040
77	30	15	636166	3542.49	DFT-s-OFDM QPSK	1@1	24.44	22.24	0.1675
77	30	15	636166	3542.49	DFT-s-OFDM 16 QAM	1@1	22.53	20.33	0.1079
77	30	20	630668	3460.02	DFT-s-OFDM QPSK	1@1	24.63	22.43	0.1750
77	30	20	630668	3460.02	DFT-s-OFDM 16 QAM	1@1	22.78	20.58	0.1143
77	30	20	633334	3500.01	DFT-s-OFDM QPSK	1@1	24.34	22.14	0.1637
77	30	20	633334	3500.01	DFT-s-OFDM 16 QAM	1@1	22.35	20.15	0.1035
77	30	20	636000	3540	DFT-s-OFDM QPSK	1@1	24.27	22.07	0.1611
77	30	20	636000	3540	DFT-s-OFDM 16 QAM	1@1	22.35	20.15	0.1035
77	30	25	630834	3462.51	DFT-s-OFDM QPSK	1@1	24.83	22.63	0.1832
77	30	25	630834	3462.51	DFT-s-OFDM 16 QAM	1@1	22.82	20.62	0.1153

77	30	25	633334	3500.01	DFT-s-OFDM QPSK	1@1	24.42	22.22	0.1667
77	30	25	633334	3500.01	DFT-s-OFDM 16 QAM	1@1	22.44	20.24	0.1057
77	30	25	635832	3537.48	DFT-s-OFDM QPSK	1@1	24.49	22.29	0.1694
77	30	25	635832	3537.48	DFT-s-OFDM 16 QAM	1@1	22.39	20.19	0.1045
77	30	30	631000	3465	DFT-s-OFDM QPSK	1@1	24.74	22.54	0.1795
77	30	30	631000	3465	DFT-s-OFDM 16 QAM	1@1	22.65	20.45	0.1109
77	30	30	633334	3500.01	DFT-s-OFDM QPSK	1@1	24.44	22.24	0.1675
77	30	30	633334	3500.01	DFT-s-OFDM 16 QAM	1@1	22.5	20.3	0.1072
77	30	30	635666	3534.99	DFT-s-OFDM QPSK	1@1	24.46	22.26	0.1683
77	30	30	635666	3534.99	DFT-s-OFDM 16 QAM	1@1	22.54	20.34	0.1081
77	30	40	631334	3470.01	DFT-s-OFDM QPSK	1@1	24.62	22.42	0.1746
77	30	40	631334	3470.01	DFT-s-OFDM 16 QAM	1@1	22.6	20.4	0.1096
77	30	40	633334	3500.01	DFT-s-OFDM QPSK	1@1	24.4	22.2	0.1660
77	30	40	633334	3500.01	DFT-s-OFDM 16 QAM	1@1	22.41	20.21	0.1050
77	30	40	635332	3529.98	DFT-s-OFDM QPSK	1@1	24.15	21.95	0.1567
77	30	40	635332	3529.98	DFT-s-OFDM 16 QAM	1@1	22.13	19.93	0.0984
77	30	50	631668	3475.02	DFT-s-OFDM QPSK	1@1	24.78	22.58	0.1811
77	30	50	631668	3475.02	DFT-s-OFDM 16 QAM	1@1	22.65	20.45	0.1109
77	30	50	633334	3500.01	DFT-s-OFDM QPSK	1@1	24.49	22.29	0.1694
77	30	50	633334	3500.01	DFT-s-OFDM 16 QAM	1@1	22.51	20.31	0.1074
77	30	50	635000	3525	DFT-s-OFDM QPSK	1@1	24.31	22.11	0.1626
77	30	50	635000	3525	DFT-s-OFDM 16 QAM	1@1	22.26	20.06	0.1014
77	30	60	632000	3480	DFT-s-OFDM QPSK	1@1	24.66	22.46	0.1762
77	30	60	632000	3480	DFT-s-OFDM 16 QAM	1@1	22.56	20.36	0.1086

77	30	60	633334	3500.01	DFT-s-OFDM QPSK	1@1	24.4	22.2	0.1660
77	30	60	633334	3500.01	DFT-s-OFDM 16 QAM	1@1	22.28	20.08	0.1019
77	30	60	634666	3519.99	DFT-s-OFDM QPSK	1@1	24.34	22.14	0.1637
77	30	60	634666	3519.99	DFT-s-OFDM 16 QAM	1@1	22.21	20.01	0.1002
77	30	70	632334	3485.01	DFT-s-OFDM QPSK	1@1	24.54	22.34	0.1714
77	30	70	632334	3485.01	DFT-s-OFDM 16 QAM	1@1	22.52	20.32	0.1076
77	30	70	633334	3500.01	DFT-s-OFDM QPSK	1@1	24.52	22.32	0.1706
77	30	70	633334	3500.01	DFT-s-OFDM 16 QAM	1@1	22.53	20.33	0.1079
77	30	70	634332	3514.98	DFT-s-OFDM QPSK	1@1	24.54	22.34	0.1714
77	30	70	634332	3514.98	DFT-s-OFDM 16 QAM	1@1	22.48	20.28	0.1067
77	30	80	632668	3490.02	DFT-s-OFDM QPSK	1@1	24.67	22.47	0.1766
77	30	80	632668	3490.02	DFT-s-OFDM 16 QAM	1@1	22.87	20.67	0.1167
77	30	80	633334	3500.01	DFT-s-OFDM QPSK	1@1	24.6	22.4	0.1738
77	30	80	633334	3500.01	DFT-s-OFDM 16 QAM	1@1	22.44	20.24	0.1057
77	30	80	634000	3510	DFT-s-OFDM QPSK	1@1	24.63	22.43	0.1750
77	30	80	634000	3510	DFT-s-OFDM 16 QAM	1@1	22.59	20.39	0.1094
77	30	90	633000	3495	DFT-s-OFDM QPSK	1@1	24.73	22.53	0.1791
77	30	90	633000	3495	DFT-s-OFDM 16 QAM	1@1	22.78	20.58	0.1143
77	30	90	633334	3500.01	DFT-s-OFDM QPSK	1@1	24.76	22.56	0.1803
77	30	90	633334	3500.01	DFT-s-OFDM 16 QAM	1@1	22.79	20.59	0.1146
77	30	90	633666	3504.99	DFT-s-OFDM QPSK	1@1	24.71	22.51	0.1782
77	30	90	633666	3504.99	DFT-s-OFDM 16 QAM	1@1	22.71	20.51	0.1125
77	30	100	633334	3500.01	DFT-s-OFDM PI/2 BPSK	135@67	24.48	22.28	0.1690
77	30	100	633334	3500.01	DFT-s-OFDM PI/2 BPSK	1@1	24.87	22.67	0.1849

77	30	100	633334	3500.01	DFT-s-OFDM PI/2 BPSK	1@271	24.54	22.34	0.1714
77	30	100	633334	3500.01	DFT-s-OFDM QPSK	135@67	24.46	22.26	0.1683
77	30	100	633334	3500.01	DFT-s-OFDM QPSK	1@1	24.85	22.65	0.1841
77	30	100	633334	3500.01	DFT-s-OFDM QPSK	1@271	24.47	22.27	0.1687
77	30	100	633334	3500.01	DFT-s-OFDM 16 QAM	135@67	22.59	20.39	0.1094
77	30	100	633334	3500.01	DFT-s-OFDM 16 QAM	1@1	22.9	20.7	0.1175
77	30	100	633334	3500.01	DFT-s-OFDM 16 QAM	1@271	22.52	20.32	0.1076
77	30	100	633334	3500.01	DFT-s-OFDM 64 QAM	135@67	20.35	18.15	0.0653
77	30	100	633334	3500.01	DFT-s-OFDM 64 QAM	1@1	20.83	18.63	0.0729
77	30	100	633334	3500.01	DFT-s-OFDM 64 QAM	1@271	20.46	18.26	0.0670
77	30	100	633334	3500.01	DFT-s-OFDM 256 QAM	135@67	17.98	15.78	0.0378
77	30	100	633334	3500.01	DFT-s-OFDM 256 QAM	1@1	18.05	15.85	0.0385
77	30	100	633334	3500.01	DFT-s-OFDM 256 QAM	1@271	17.92	15.72	0.0373
77	30	100	633334	3500.01	CP-OFDM QPSK	137@68	21.89	19.69	0.0931
77	30	100	633334	3500.01	CP-OFDM QPSK	1@1	22.21	20.01	0.1002
77	30	100	633334	3500.01	CP-OFDM QPSK	1@271	21.88	19.68	0.0929

## Frequency Stability

NR Band	SCS (kHz)	Bandwidth (MHz)	Arfcn	Freq (MHz)	Modulation	RB	Deviation (ppm)	Verdict	Environment
77	30	20	633334	3500.01	DFT-s-OFDM QPSK	50@0	0.0039	PASS	NV
77	30	20	633334	3500.01	DFT-s-OFDM QPSK	50@0	0.0052	PASS	LV
77	30	20	633334	3500.01	DFT-s-OFDM QPSK	50@0	0.0041	PASS	HV
77	30	20	633334	3500.01	DFT-s-OFDM QPSK	50@0	0.0035	PASS	-30°C
77	30	20	633334	3500.01	DFT-s-OFDM QPSK	50@0	0.0046	PASS	-20°C
77	30	20	633334	3500.01	DFT-s-OFDM QPSK	50@0	0.0045	PASS	-10°C
77	30	20	633334	3500.01	DFT-s-OFDM QPSK	50@0	0.0037	PASS	0°C
77	30	20	633334	3500.01	DFT-s-OFDM QPSK	50@0	0.0024	PASS	10°C
77	30	20	633334	3500.01	DFT-s-OFDM QPSK	50@0	0.0039	PASS	20°C
77	30	20	633334	3500.01	DFT-s-OFDM QPSK	50@0	0.0056	PASS	30°C
77	30	20	633334	3500.01	DFT-s-OFDM QPSK	50@0	0.0049	PASS	40°C
77	30	20	633334	3500.01	DFT-s-OFDM QPSK	50@0	0.0050	PASS	50°C

# Peak to Average Ratio

NR Band	SCS (kHz)	Bandwidth (MHz)	Arfcn	Freq (MHz)	Modulation	RB	Result (dB)	Limit (dB)	Verdict
77	30	20	633334	3500.01	DFT-s-OFDM PI/2 BPSK	50@0	4.18	13	PASS
77	30	20	633334	3500.01	DFT-s-OFDM QPSK	50@0	5.87	13	PASS

N77(20M)\_DFT-s-OFDM\_PI\_2-BPSK\_Outer\_Full\_Mid\_CH

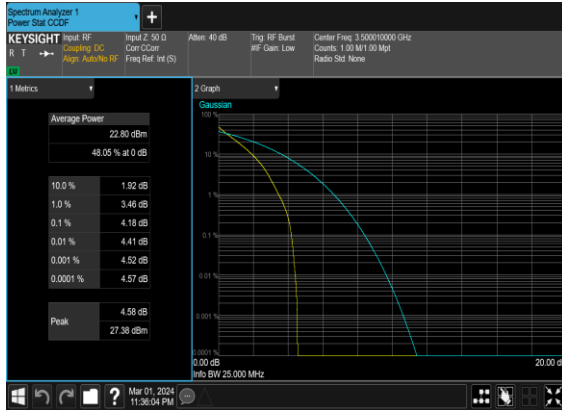

N77(20M)\_DFT-s-OFDM\_QPSK\_Outer\_Full\_Mid\_CH

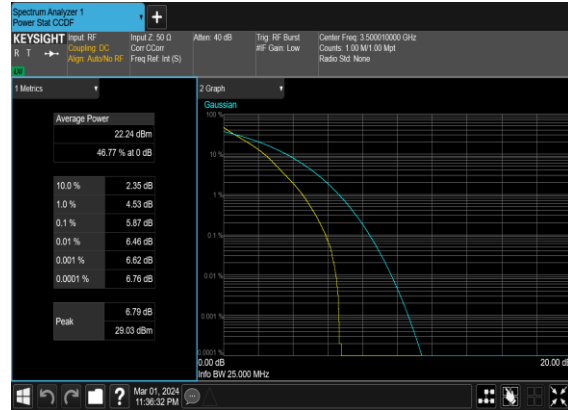

## Occupied Bandwidth

NR Band	SCS (kHz)	Bandwidth (MHz)	Arfcn	Freq (MHz)	Modulation	RB	OBW (MHz)	26dB BW (MHz)
77	30	10	633334	3500.01	CP-OFDM QPSK	24@0	8.567	9.472
77	30	10	633334	3500.01	CP-OFDM 16 QAM	24@0	8.5513	9.421
77	30	10	633334	3500.01	CP-OFDM 64 QAM	24@0	8.5889	9.637
77	30	10	633334	3500.01	CP-OFDM 256 QAM	24@0	8.5354	9.407
77	30	15	633334	3500.01	CP-OFDM QPSK	38@0	13.558	14.65
77	30	15	633334	3500.01	CP-OFDM 16 QAM	38@0	13.561	14.86
77	30	15	633334	3500.01	CP-OFDM 64 QAM	38@0	13.576	14.51
77	30	15	633334	3500.01	CP-OFDM 256 QAM	38@0	13.544	14.42
77	30	20	633334	3500.01	CP-OFDM QPSK	51@0	18.213	19.45
77	30	20	633334	3500.01	CP-OFDM 16 QAM	51@0	18.233	19.54
77	30	20	633334	3500.01	CP-OFDM 64 QAM	51@0	18.192	19.16
77	30	20	633334	3500.01	CP-OFDM 256 QAM	51@0	18.154	19.35
77	30	25	633334	3500.01	CP-OFDM QPSK	65@0	23.179	24.36
77	30	25	633334	3500.01	CP-OFDM 16 QAM	65@0	23.242	24.78
77	30	25	633334	3500.01	CP-OFDM 64 QAM	65@0	23.23	24.45
77	30	25	633334	3500.01	CP-OFDM 256 QAM	65@0	23.264	24.41
77	30	30	633334	3500.01	CP-OFDM QPSK	78@0	27.859	28.92
77	30	30	633334	3500.01	CP-OFDM 16 QAM	78@0	27.803	29.43
77	30	30	633334	3500.01	CP-OFDM 64 QAM	78@0	27.87	29.09
77	30	30	633334	3500.01	CP-OFDM 256 QAM	78@0	27.907	29.22
77	30	40	633334	3500.01	CP-OFDM QPSK	106@0	37.755	39.06
77	30	40	633334	3500.01	CP-OFDM 16 QAM	106@0	37.866	39.71
77	30	40	633334	3500.01	CP-OFDM 64 QAM	106@0	37.897	39.5
77	30	40	633334	3500.01	CP-OFDM 256 QAM	106@0	37.881	39.08
77	30	50	633334	3500.01	CP-OFDM QPSK	133@0	47.557	49.0

77	30	50	633334	3500.01	CP-OFDM 16 QAM	133@0	47.58	49.12
77	30	50	633334	3500.01	CP-OFDM 64 QAM	133@0	47.677	49.31
77	30	50	633334	3500.01	CP-OFDM 256 QAM	133@0	47.623	49.09
77	30	60	633334	3500.01	CP-OFDM QPSK	162@0	57.877	59.95
77	30	60	633334	3500.01	CP-OFDM 16 QAM	162@0	57.867	59.69
77	30	60	633334	3500.01	CP-OFDM 64 QAM	162@0	57.821	59.93
77	30	60	633334	3500.01	CP-OFDM 256 QAM	162@0	57.79	59.61
77	30	70	633334	3500.01	CP-OFDM QPSK	189@0	67.523	70.03
77	30	70	633334	3500.01	CP-OFDM 16 QAM	189@0	67.308	69.76
77	30	70	633334	3500.01	CP-OFDM 64 QAM	189@0	67.566	69.78
77	30	70	633334	3500.01	CP-OFDM 256 QAM	189@0	67.309	69.66
77	30	80	633334	3500.01	CP-OFDM QPSK	217@0	77.466	79.9
77	30	80	633334	3500.01	CP-OFDM 16 QAM	217@0	77.466	79.87
77	30	80	633334	3500.01	CP-OFDM 64 QAM	217@0	77.576	79.97
77	30	80	633334	3500.01	CP-OFDM 256 QAM	217@0	77.327	79.82
77	30	90	633334	3500.01	CP-OFDM QPSK	245@0	87.521	90.3
77	30	90	633334	3500.01	CP-OFDM 16 QAM	245@0	87.36	90.29
77	30	90	633334	3500.01	CP-OFDM 64 QAM	245@0	87.313	90.28
77	30	90	633334	3500.01	CP-OFDM 256 QAM	245@0	87.328	90.45
77	30	100	633334	3500.01	CP-OFDM QPSK	273@0	97.372	100.6
77	30	100	633334	3500.01	CP-OFDM 16 QAM	273@0	97.419	100.5
77	30	100	633334	3500.01	CP-OFDM 64 QAM	273@0	97.143	100.5
77	30	100	633334	3500.01	CP-OFDM 256 QAM	273@0	97.5	100.6

### N77(10M)\_CP-OFDM\_QPSK\_Outer\_Full\_Mid\_CH

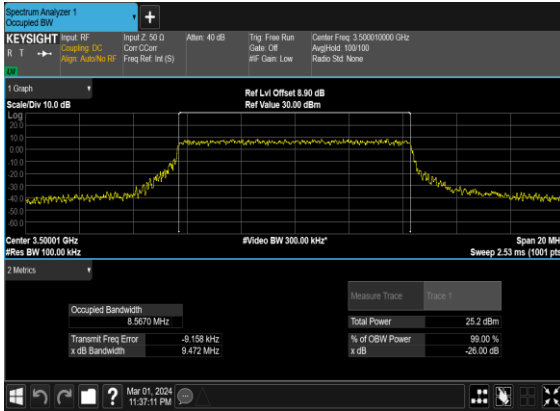

### N77(10M)\_CP-OFDM\_16 QAM\_Outer\_Full\_Mid\_CH



### N77(10M)\_CP-OFDM\_64 QAM\_Outer\_Full\_Mid\_CH



### N77(10M)\_CP-OFDM\_256 QAM\_Outer\_Full\_Mid\_CH

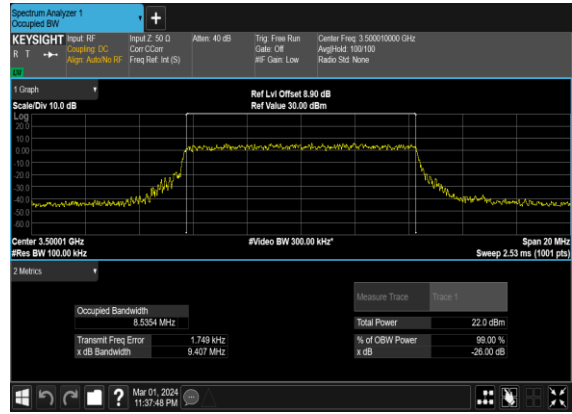

### N77(15M)\_CP-OFDM\_QPSK\_Outer\_Full\_Mid\_CH

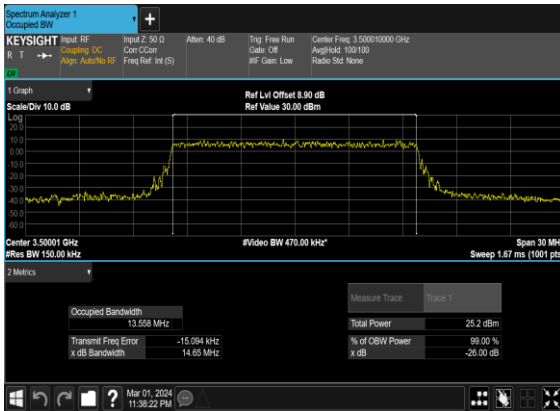

### N77(15M)\_CP-OFDM\_16 QAM\_Outer\_Full\_Mid\_CH



### N77(15M)\_CP-OFDM\_64 QAM\_Outer\_Full\_Mid\_CH

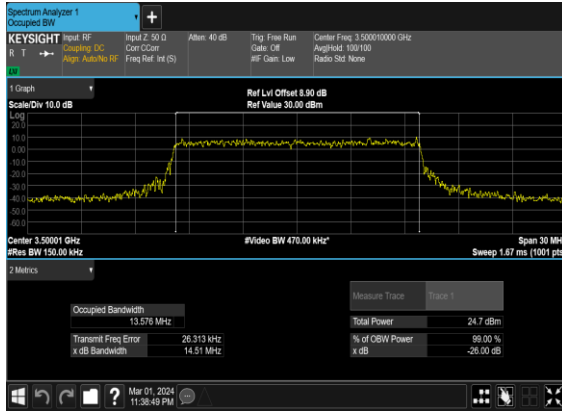

### N77(15M)\_CP-OFDM\_256 QAM\_Outer\_Full\_Mid\_CH

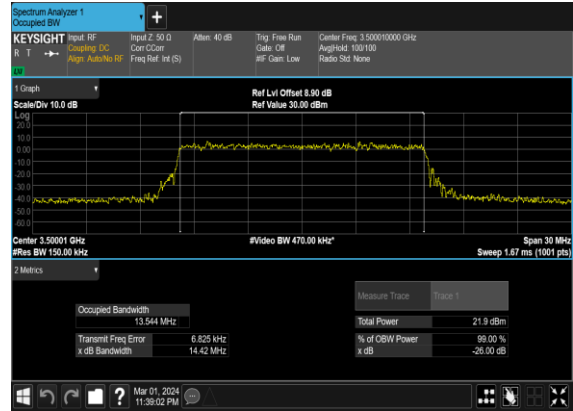

### N77(20M)\_CP- OFDM\_QPSK\_Outer\_Full\_Mid\_CH

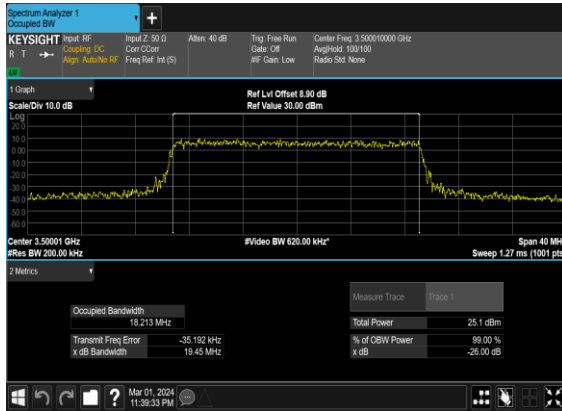

### N77(20M)\_CP-OFDM\_16 QAM\_Outer\_Full\_Mid\_CH



### N77(20M)\_CP-OFDM\_64 QAM\_Outer\_Full\_Mid\_CH

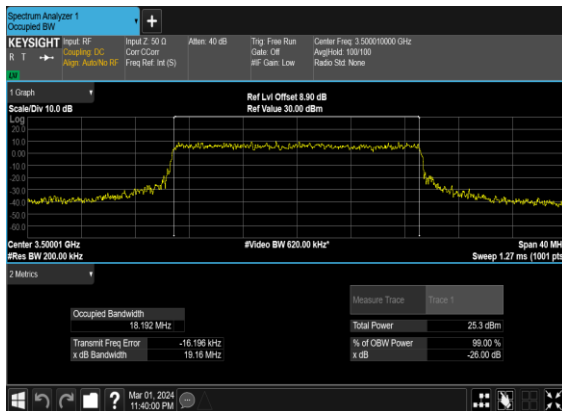

### N77(20M)\_CP-OFDM\_256 QAM\_Outer\_Full\_Mid\_CH

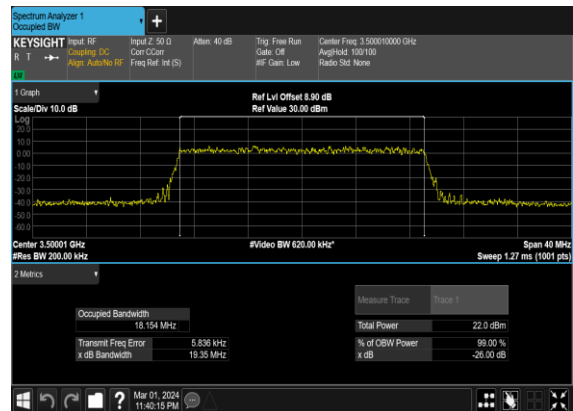

### N77(25M)\_CP-OFDM\_QPSK\_Outer\_Full\_Mid\_CH

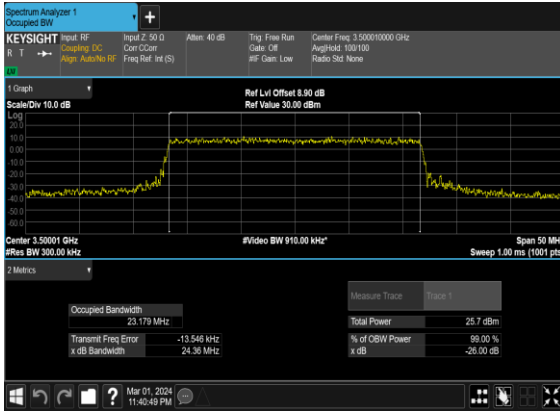

### N77(25M)\_CP-OFDM\_16QAM\_Outer\_Full\_Mid\_CH

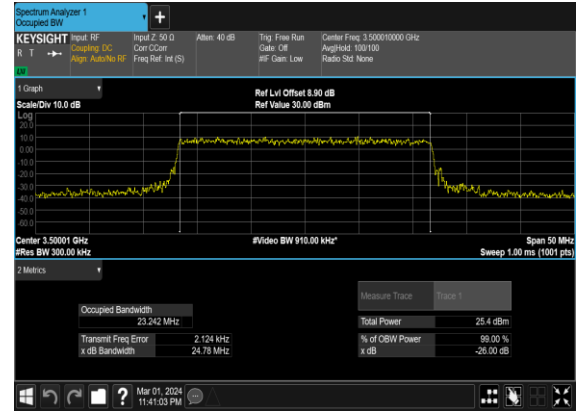

### N77(25M)\_CP-OFDM\_64QAM\_Outer\_Full\_Mid\_CH



### N77(25M)\_CP-OFDM\_256QAM\_Outer\_Full\_Mid\_CH

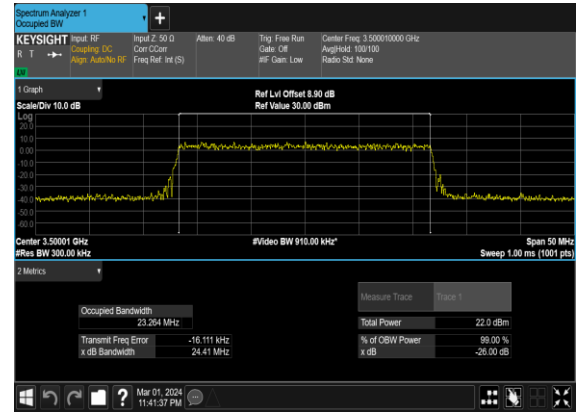

### N77(30M)\_CP-OFDM\_QPSK\_Outer\_Full\_Mid\_CH

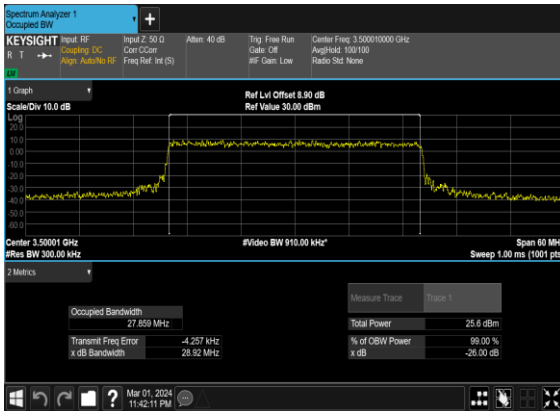

### N77(30M)\_CP-OFDM\_16QAM\_Outer\_Full\_Mid\_CH

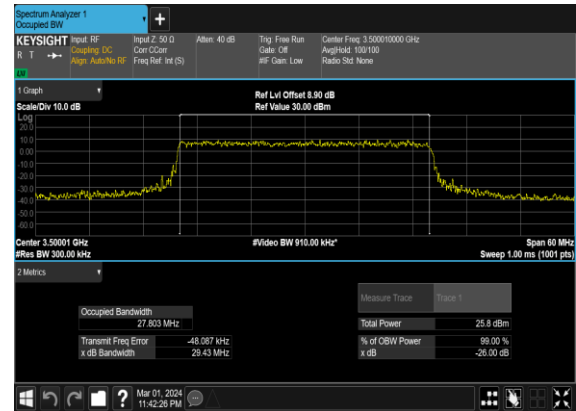

### N77(30M)\_CP-OFDM\_64 QAM\_Outer\_Full\_Mid\_CH

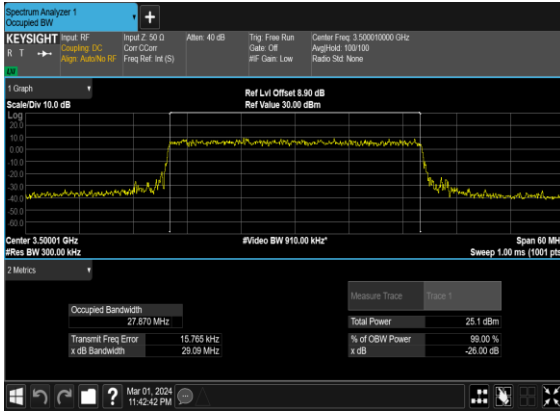

### N77(30M)\_CP-OFDM\_256 QAM\_Outer\_Full\_Mid\_CH

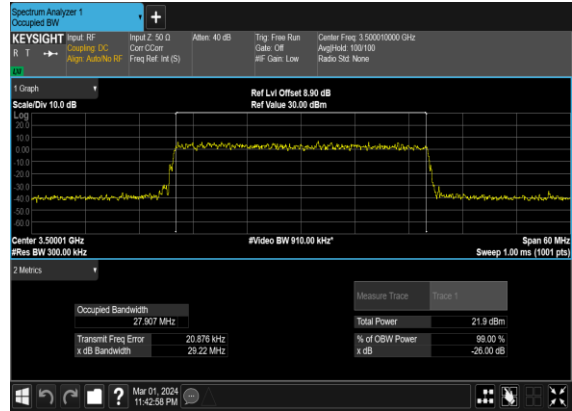

### N77(40M)\_CP- OFDM\_QPSK\_Outer\_Full\_Mid\_CH



### N77(40M)\_CP-OFDM\_16 QAM\_Outer\_Full\_Mid\_CH



### N77(40M)\_CP-OFDM\_64 QAM\_Outer\_Full\_Mid\_CH

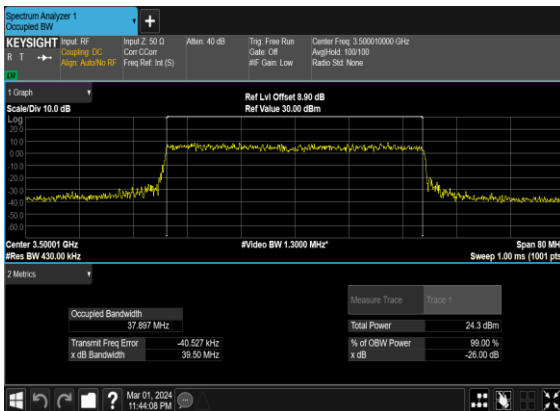

### N77(40M)\_CP-OFDM\_256 QAM\_Outer\_Full\_Mid\_CH

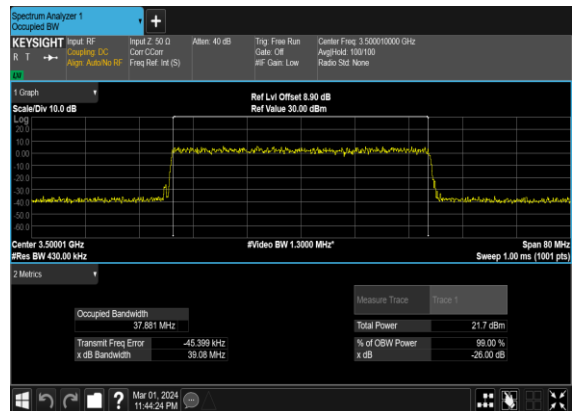

### N77(50M)\_CP-OFDM\_QPSK\_Outer\_Full\_Mid\_CH

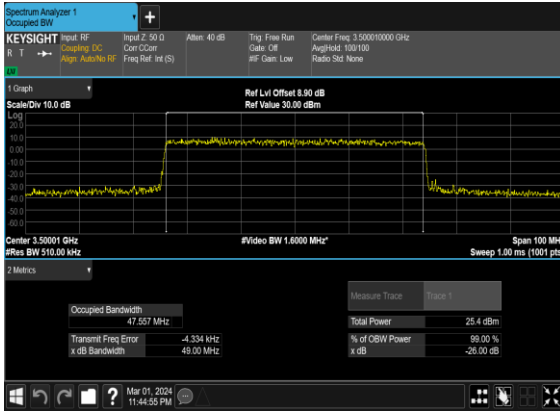

### N77(50M)\_CP-OFDM\_16 QAM\_Outer\_Full\_Mid\_CH

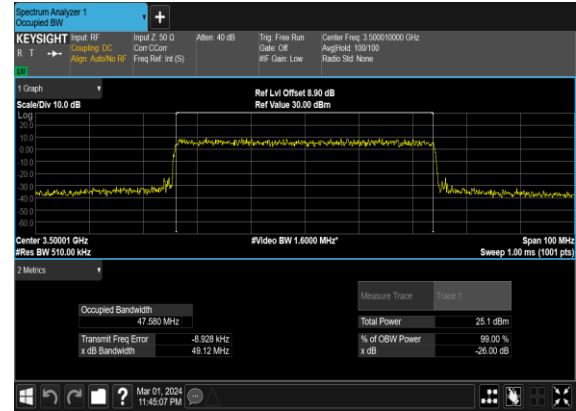

### N77(50M)\_CP-OFDM\_64 QAM\_Outer\_Full\_Mid\_CH



### N77(50M)\_CP-OFDM\_256 QAM\_Outer\_Full\_Mid\_CH

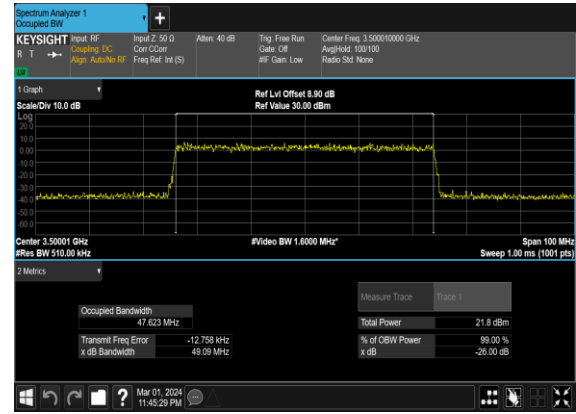

### N77(60M)\_CP-OFDM\_QPSK\_Outer\_Full\_Mid\_CH

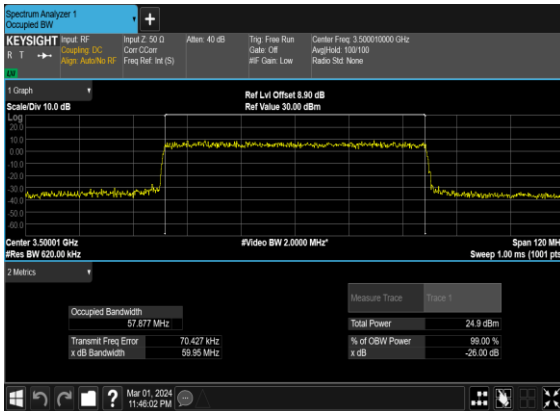

### N77(60M)\_CP-OFDM\_16 QAM\_Outer\_Full\_Mid\_CH

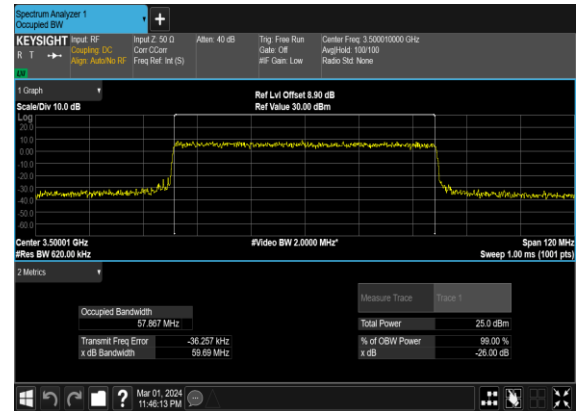

### N77(60M)\_CP-OFDM\_64 QAM\_Outer\_Full\_Mid\_CH

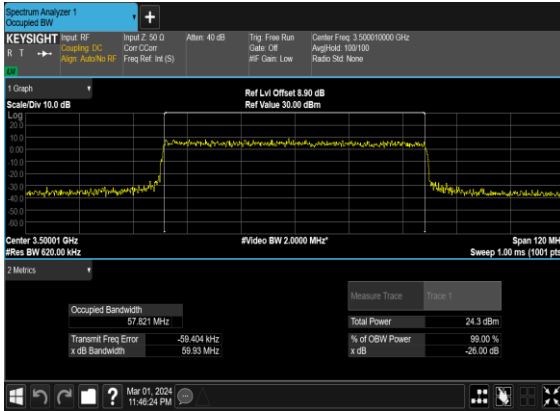

### N77(60M)\_CP-OFDM\_256 QAM\_Outer\_Full\_Mid\_CH

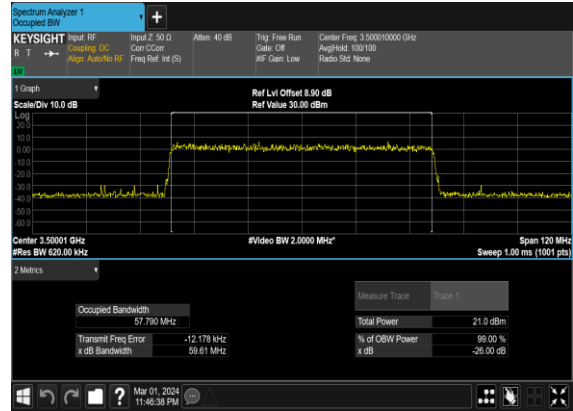

### N77(70M)\_CP- OFDM\_QPSK\_Outer\_Full\_Mid\_CH

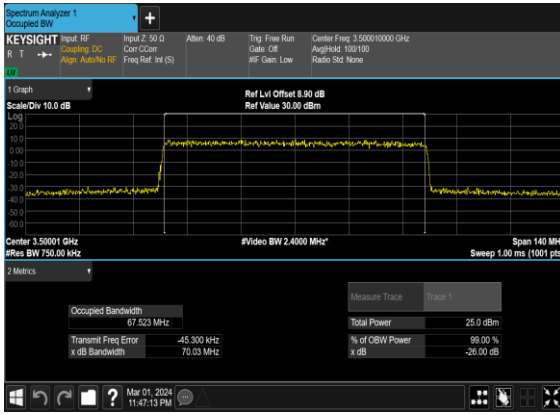

### N77(70M)\_CP-OFDM\_16 QAM\_Outer\_Full\_Mid\_CH

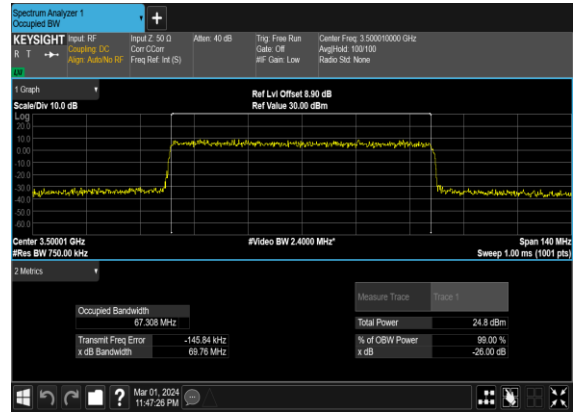

### N77(70M)\_CP-OFDM\_64 QAM\_Outer\_Full\_Mid\_CH

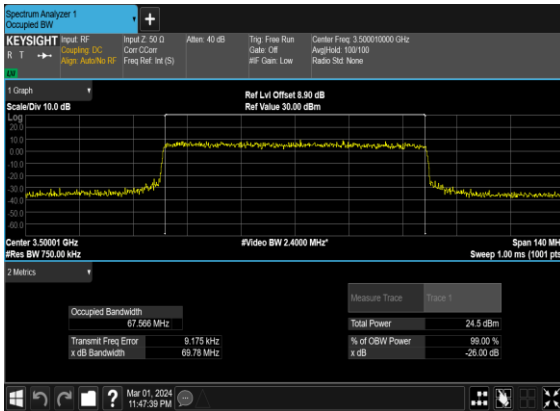

### N77(70M)\_CP-OFDM\_256 QAM\_Outer\_Full\_Mid\_CH

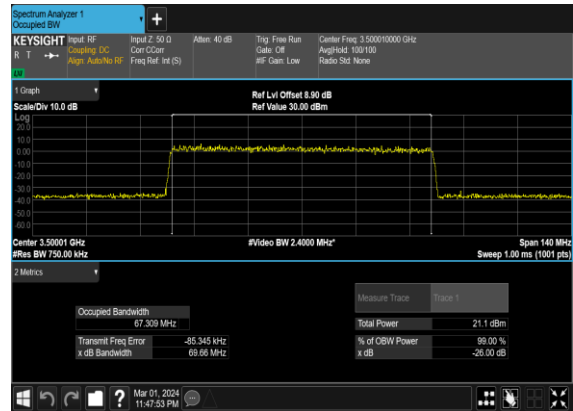

### N77(80M)\_CP-OFDM\_QPSK\_Outer\_Full\_Mid\_CH

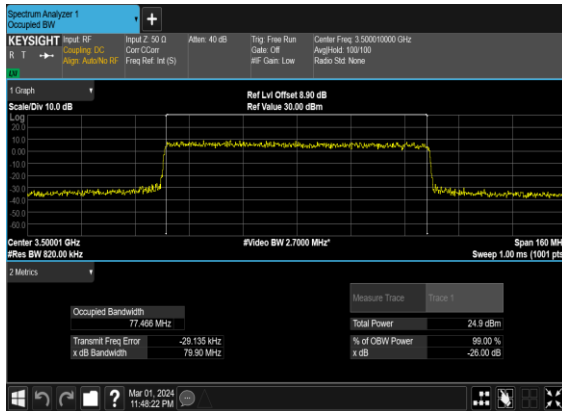

### N77(80M)\_CP-OFDM\_16QAM\_Outer\_Full\_Mid\_CH

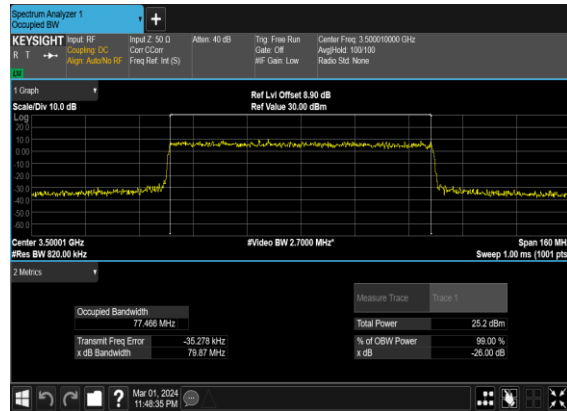

### N77(80M)\_CP-OFDM\_64QAM\_Outer\_Full\_Mid\_CH

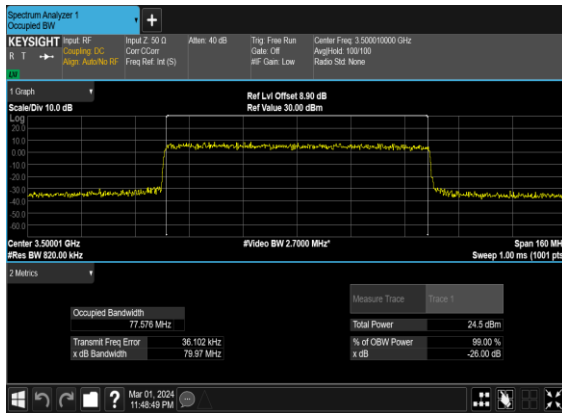

### N77(80M)\_CP-OFDM\_256QAM\_Outer\_Full\_Mid\_CH

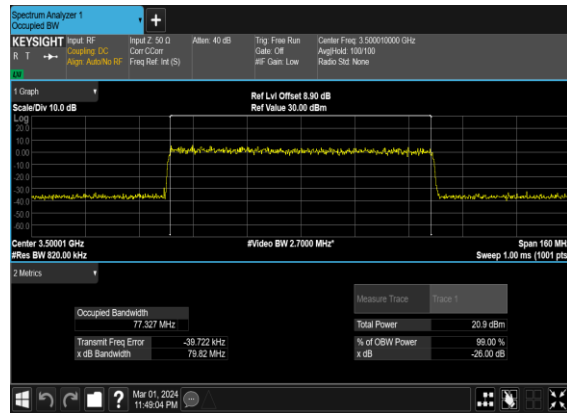

### N77(90M)\_CP-OFDM\_QPSK\_Outer\_Full\_Mid\_CH

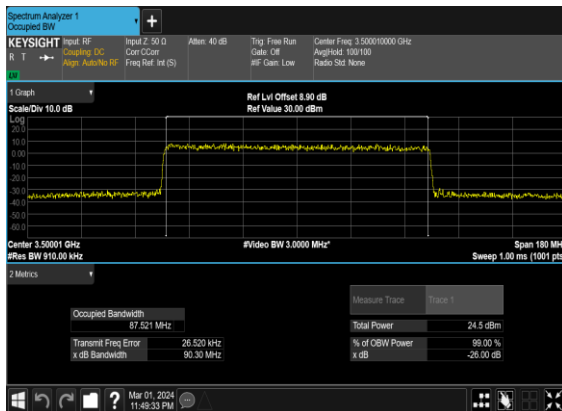

### N77(90M)\_CP-OFDM\_16QAM\_Outer\_Full\_Mid\_CH

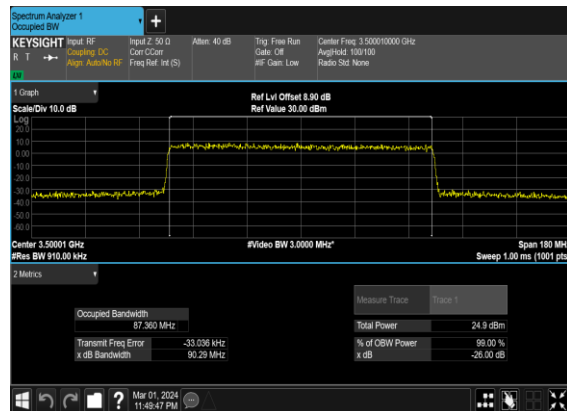

### N77(90M)\_CP-OFDM\_64 QAM\_Outer\_Full\_Mid\_CH

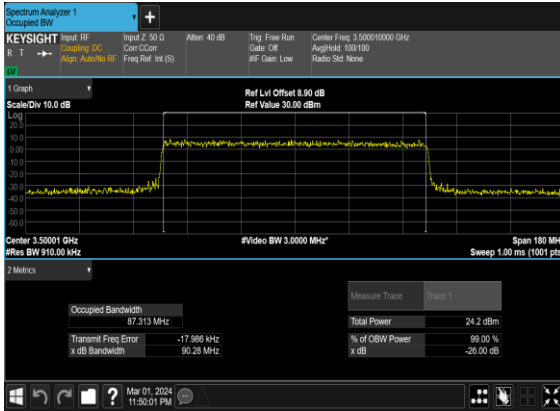

### N77(90M)\_CP-OFDM\_256 QAM\_Outer\_Full\_Mid\_CH

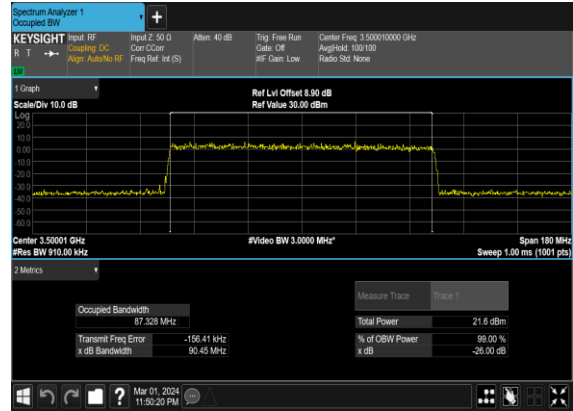

### N77(100M)\_CP- OFDM\_QPSK\_Outer\_Full\_Mid\_CH

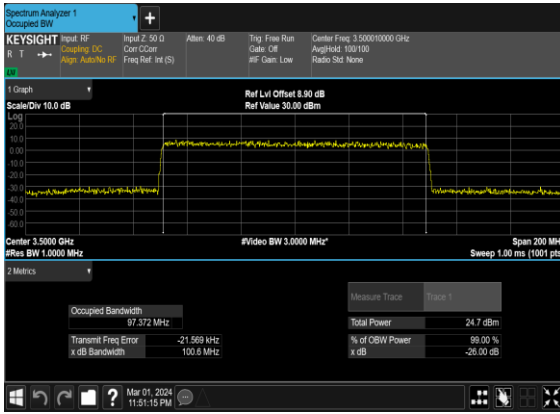

### N77(100M)\_CP-OFDM\_16 QAM\_Outer\_Full\_Mid\_CH

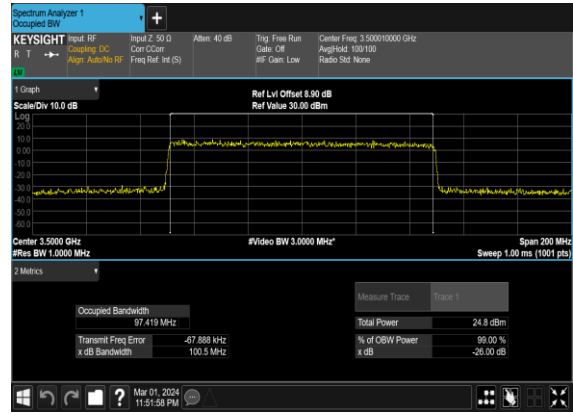

### N77(100M)\_CP-OFDM\_64 QAM\_Outer\_Full\_Mid\_CH

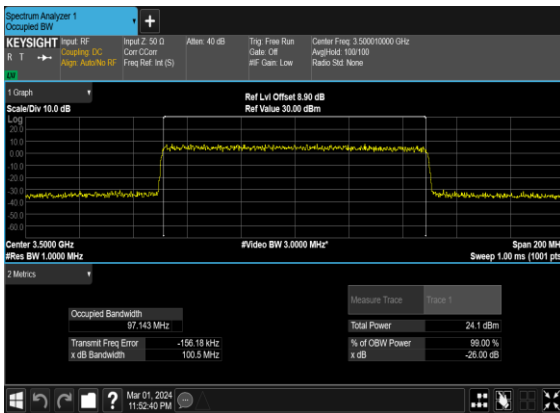

### N77(100M)\_CP-OFDM\_256 QAM\_Outer\_Full\_Mid\_CH

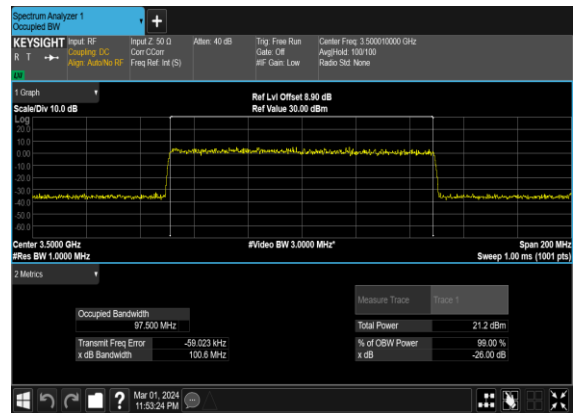

## Conducted Spurious Emissions

NR Band	SCS (kHz)	Bandwidth (MHz)	Arfcn	Freq (MHz)	Modulation	RB	Result	Verdict
77	30	10	630334	3455.01	DFT-s-OFDM BPSK	1@0	see graph	---
77	30	10	630334	3455.01	DFT-s-OFDM BPSK	1@0	see graph	<b>PASS</b>
77	30	10	630334	3455.01	DFT-s-OFDM BPSK	1@0	see graph	<b>PASS</b>
77	30	10	630334	3455.01	DFT-s-OFDM QPSK	1@0	see graph	---
77	30	10	630334	3455.01	DFT-s-OFDM QPSK	1@0	see graph	<b>PASS</b>
77	30	10	630334	3455.01	DFT-s-OFDM QPSK	1@0	see graph	<b>PASS</b>
77	30	10	633334	3500.01	DFT-s-OFDM BPSK	1@0	see graph	---
77	30	10	633334	3500.01	DFT-s-OFDM BPSK	1@0	see graph	<b>PASS</b>
77	30	10	633334	3500.01	DFT-s-OFDM BPSK	1@0	see graph	<b>PASS</b>
77	30	10	633334	3500.01	DFT-s-OFDM QPSK	1@0	see graph	---
77	30	10	633334	3500.01	DFT-s-OFDM QPSK	1@0	see graph	<b>PASS</b>
77	30	10	633334	3500.01	DFT-s-OFDM QPSK	1@0	see graph	<b>PASS</b>
77	30	10	636332	3544.98	DFT-s-OFDM BPSK	1@0	see graph	---
77	30	10	636332	3544.98	DFT-s-OFDM BPSK	1@0	see graph	<b>PASS</b>
77	30	10	636332	3544.98	DFT-s-OFDM BPSK	1@0	see graph	<b>PASS</b>
77	30	10	636332	3544.98	DFT-s-OFDM QPSK	1@0	see graph	---
77	30	10	636332	3544.98	DFT-s-OFDM QPSK	1@0	see graph	<b>PASS</b>
77	30	10	636332	3544.98	DFT-s-OFDM QPSK	1@0	see graph	<b>PASS</b>
77	30	50	631668	3475.02	DFT-s-OFDM BPSK	1@0	see graph	---
77	30	50	631668	3475.02	DFT-s-OFDM BPSK	1@0	see graph	<b>PASS</b>
77	30	50	631668	3475.02	DFT-s-OFDM BPSK	1@0	see graph	<b>PASS</b>
77	30	50	631668	3475.02	DFT-s-OFDM QPSK	1@0	see graph	---

77	30	50	631668	3475.02	DFT-s-OFDM QPSK	1@0	see graph	PASS
77	30	50	631668	3475.02	DFT-s-OFDM QPSK	1@0	see graph	PASS
77	30	50	633334	3500.01	DFT-s-OFDM BPSK	1@0	see graph	---
77	30	50	633334	3500.01	DFT-s-OFDM BPSK	1@0	see graph	PASS
77	30	50	633334	3500.01	DFT-s-OFDM BPSK	1@0	see graph	PASS
77	30	50	633334	3500.01	DFT-s-OFDM QPSK	1@0	see graph	---
77	30	50	633334	3500.01	DFT-s-OFDM QPSK	1@0	see graph	PASS
77	30	50	633334	3500.01	DFT-s-OFDM QPSK	1@0	see graph	PASS
77	30	50	635000	3525.0	DFT-s-OFDM BPSK	1@0	see graph	---
77	30	50	635000	3525.0	DFT-s-OFDM BPSK	1@0	see graph	PASS
77	30	50	635000	3525.0	DFT-s-OFDM BPSK	1@0	see graph	PASS
77	30	50	635000	3525.0	DFT-s-OFDM QPSK	1@0	see graph	---
77	30	50	635000	3525.0	DFT-s-OFDM QPSK	1@0	see graph	PASS
77	30	50	635000	3525.0	DFT-s-OFDM QPSK	1@0	see graph	PASS
77	30	100	633334	3500.01	DFT-s-OFDM BPSK	1@0	see graph	---
77	30	100	633334	3500.01	DFT-s-OFDM BPSK	1@0	see graph	PASS
77	30	100	633334	3500.01	DFT-s-OFDM BPSK	1@0	see graph	PASS
77	30	100	633334	3500.01	DFT-s-OFDM QPSK	1@0	see graph	---
77	30	100	633334	3500.01	DFT-s-OFDM QPSK	1@0	see graph	PASS
77	30	100	633334	3500.01	DFT-s-OFDM QPSK	1@0	see graph	PASS

### N77(10M)\_DFT-s-OFDM\_BPSK\_Edge\_1RB\_Left\_Low\_CH

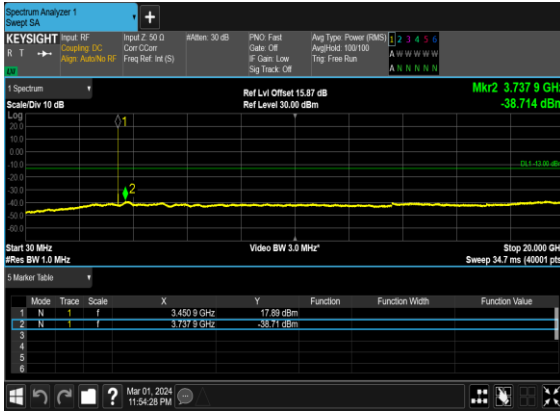

### N77(10M)\_DFT-s-OFDM\_BPSK\_Edge\_1RB\_Left\_Low\_CH

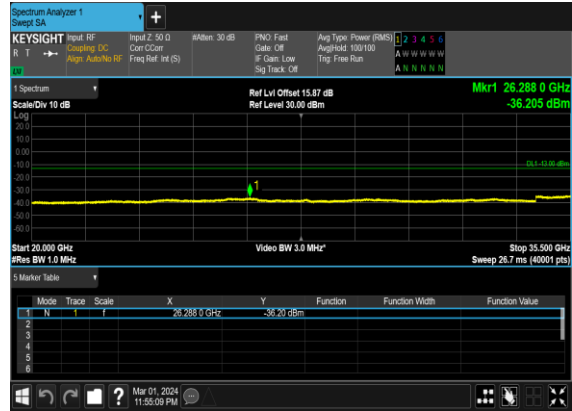

### N77(10M)\_DFT-s-OFDM\_QPSK\_Edge\_1RB\_Left\_Low\_CH

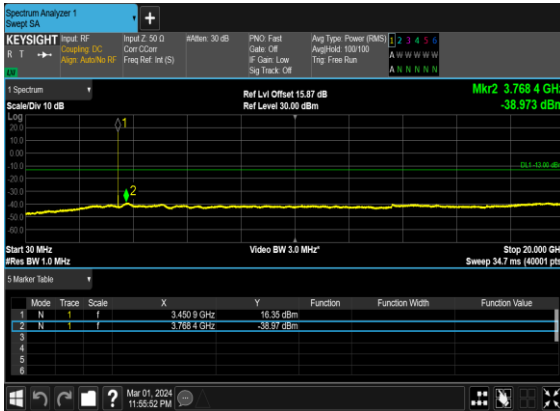

### N77(10M)\_DFT-s-OFDM\_QPSK\_Edge\_1RB\_Left\_Low\_CH

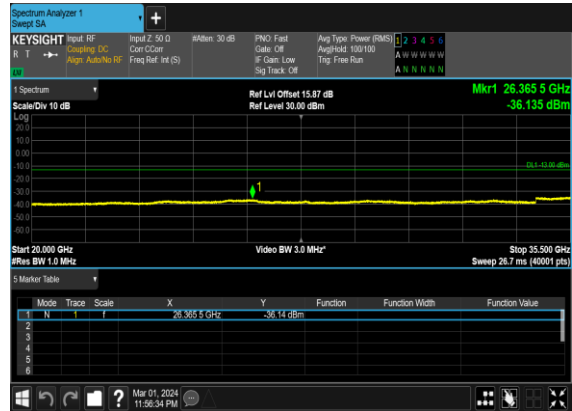

### N77(10M)\_DFT-s-OFDM\_BPSK\_Edge\_1RB\_Left\_Mid\_CH

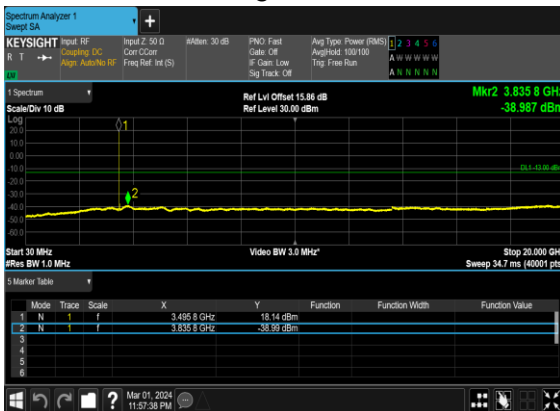

### N77(10M)\_DFT-s-OFDM\_BPSK\_Edge\_1RB\_Left\_Mid\_CH

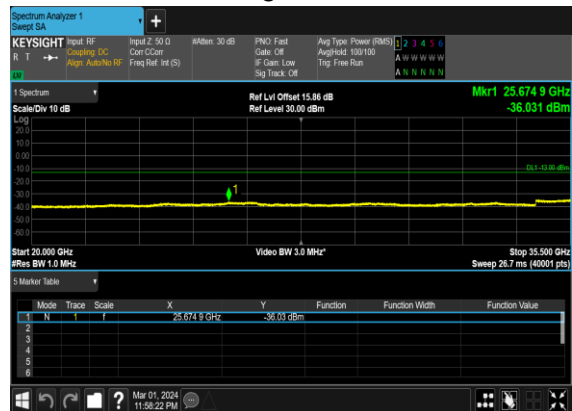

### N77(10M)\_DFT-s-OFDM\_QPSK\_Edge\_1RB\_Left\_Mid\_CH

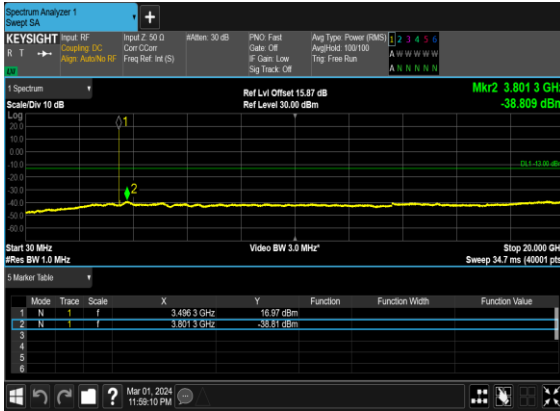

### N77(10M)\_DFT-s-OFDM\_QPSK\_Edge\_1RB\_Left\_Mid\_CH

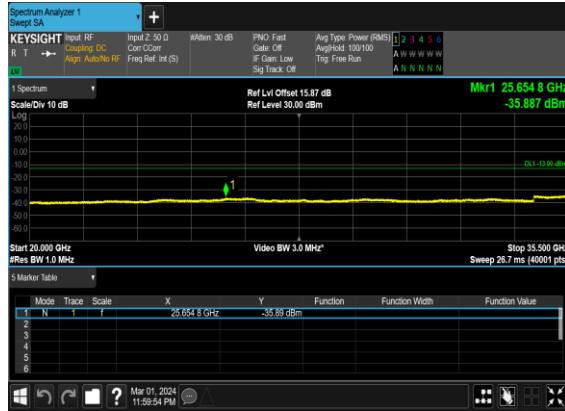

### N77(10M)\_DFT-s-OFDM\_BPSK\_Edge\_1RB\_Left\_High\_CH

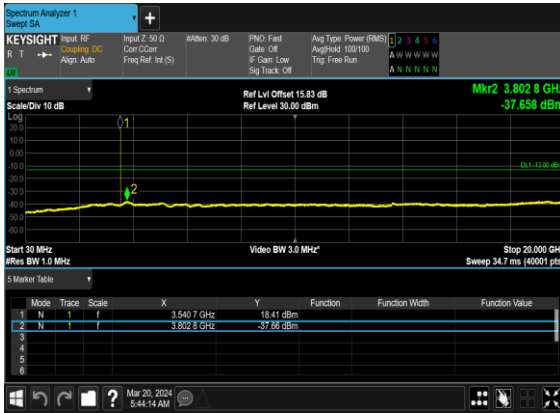

### N77(10M)\_DFT-s-OFDM\_BPSK\_Edge\_1RB\_Left\_High\_CH

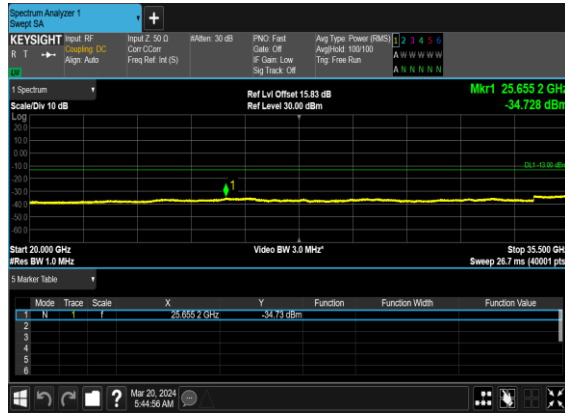

### N77(10M)\_DFT-s-OFDM\_QPSK\_Edge\_1RB\_Left\_High\_CH



### N77(10M)\_DFT-s-OFDM\_QPSK\_Edge\_1RB\_Left\_High\_CH

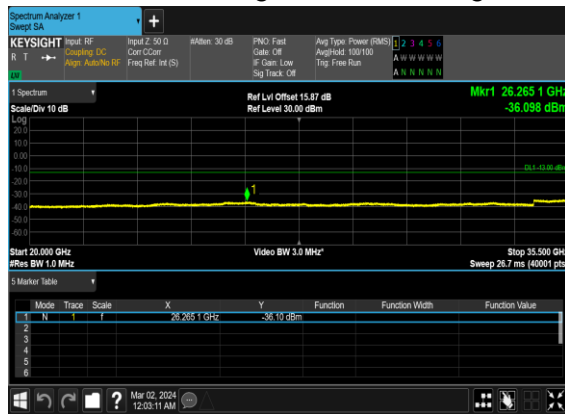

N77(50M)\_DFT-s-OFDM\_BPSK\_Edge\_1RB\_Left\_Low\_CH

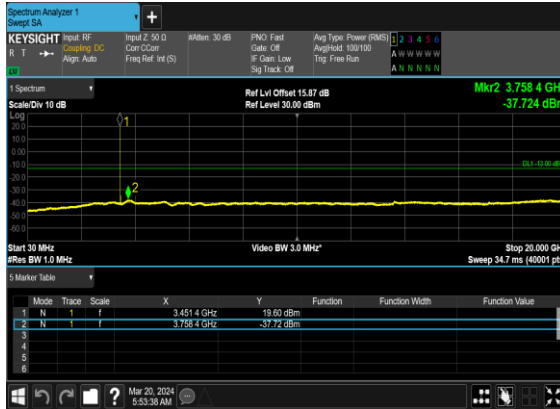

N77(50M)\_DFT-s-OFDM\_BPSK\_Edge\_1RB\_Left\_Low\_CH

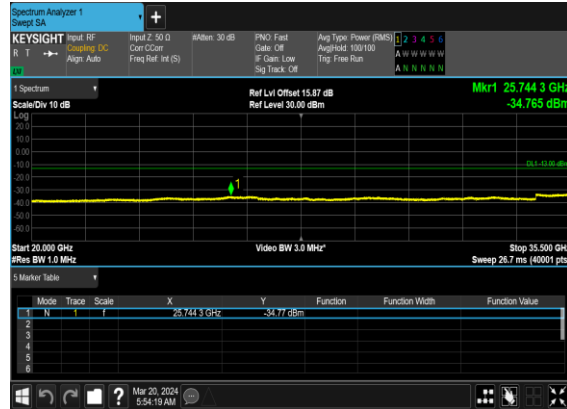

N77(50M)\_DFT-s-OFDM\_QPSK\_Edge\_1RB\_Left\_Low\_CH

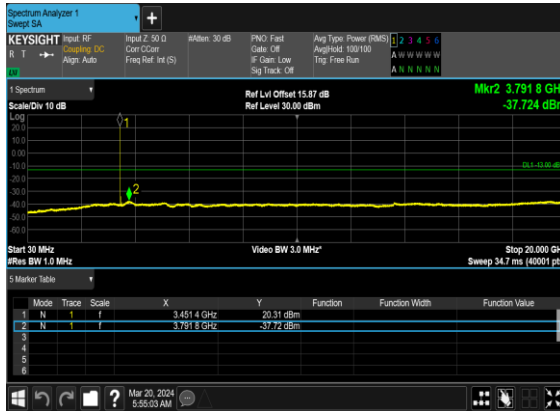

N77(50M)\_DFT-s-OFDM\_QPSK\_Edge\_1RB\_Left\_Low\_CH

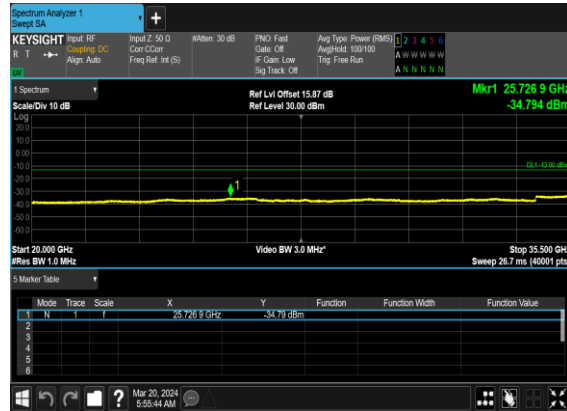

N77(50M)\_DFT-s-OFDM\_BPSK\_Edge\_1RB\_Left\_Mid\_CH

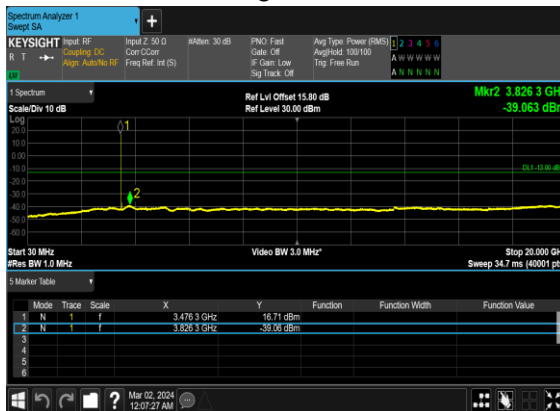

N77(50M)\_DFT-s-OFDM\_BPSK\_Edge\_1RB\_Left\_Mid\_CH

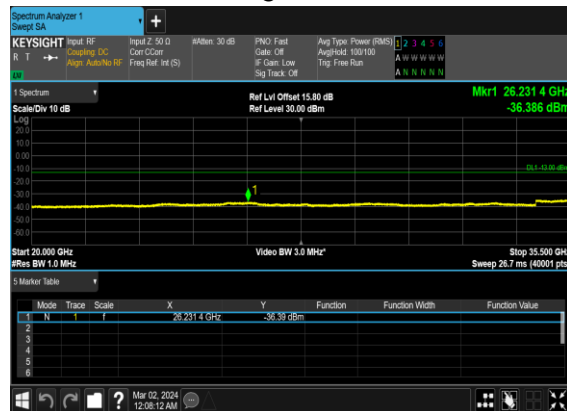

### N77(50M)\_DFT-s-OFDM\_QPSK\_Edge\_1RB\_Left\_Mid\_CH

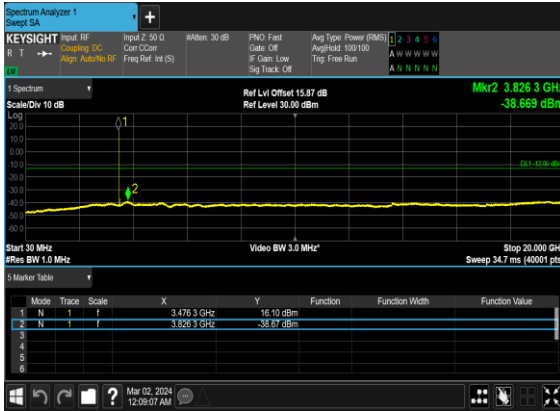

### N77(50M)\_DFT-s-OFDM\_QPSK\_Edge\_1RB\_Left\_Mid\_CH

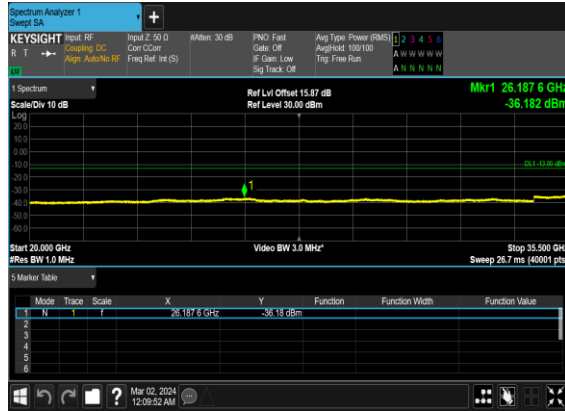

### N77(50M)\_DFT-s-OFDM\_BPSK\_Edge\_1RB\_Left\_High\_CH

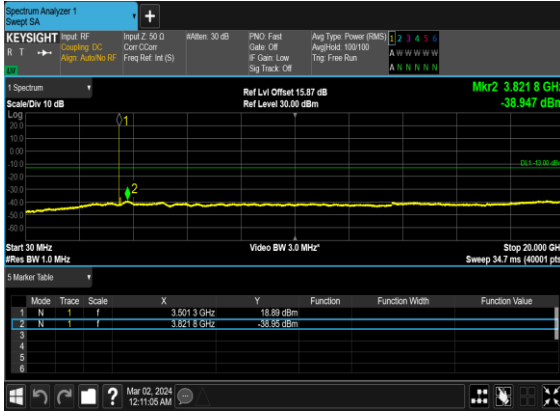

### N77(50M)\_DFT-s-OFDM\_BPSK\_Edge\_1RB\_Left\_High\_CH

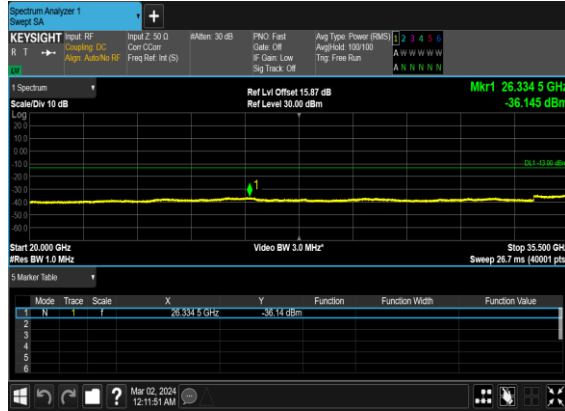

### N77(50M)\_DFT-s-OFDM\_QPSK\_Edge\_1RB\_Left\_High\_CH



### N77(50M)\_DFT-s-OFDM\_QPSK\_Edge\_1RB\_Left\_High\_CH

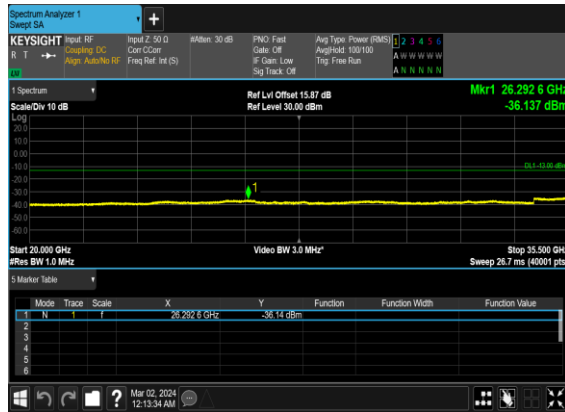

### N77(100M)\_DFT-s-OFDM\_BPSK\_Edge\_1RB\_Left\_Mid\_CH

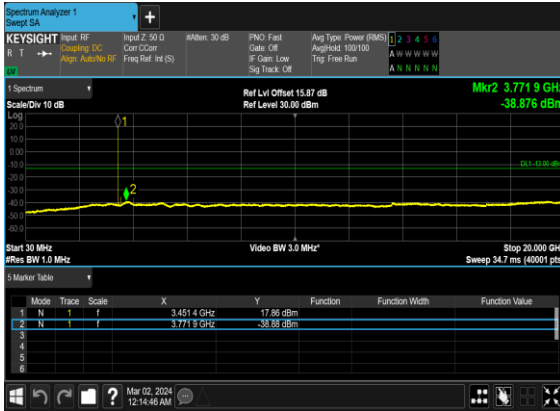

### N77(100M)\_DFT-s-OFDM\_BPSK\_Edge\_1RB\_Left\_Mid\_CH

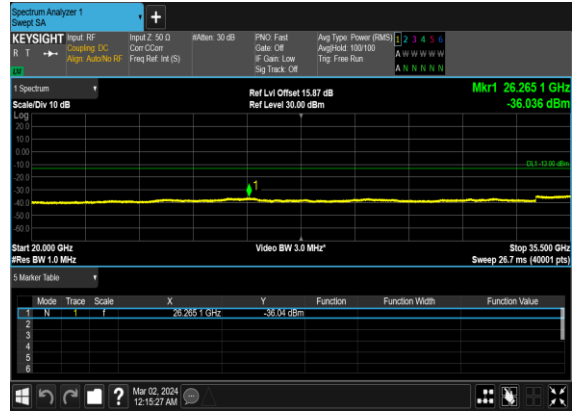

### N77(100M)\_DFT-s-OFDM\_QPSK\_Edge\_1RB\_Left\_Mid\_CH

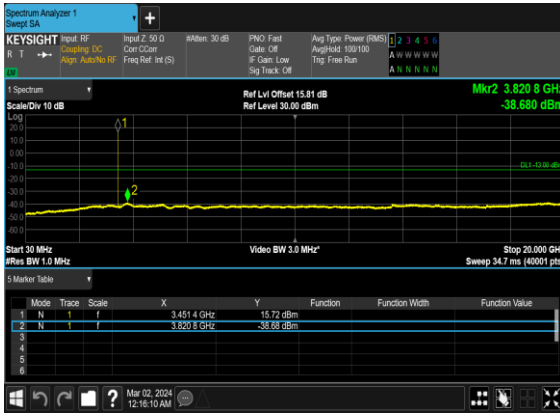

### N77(100M)\_DFT-s-OFDM\_QPSK\_Edge\_1RB\_Left\_Mid\_CH

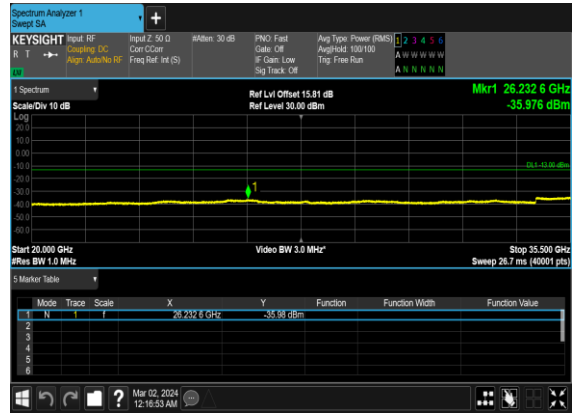

## Conducted Band Edge

NR Band	SCS (kHz)	Bandwidth (MHz)	Arfcn	Freq (MHz)	Modulation	RB	Result	Verdict
77	30	10	630334	3455.01	DFT-s-OFDM BPSK	1@0	see graph	PASS
77	30	10	630334	3455.01	DFT-s-OFDM QPSK	1@0	see graph	PASS
77	30	10	630334	3455.01	DFT-s-OFDM BPSK	24@0	see graph	PASS
77	30	10	630334	3455.01	DFT-s-OFDM QPSK	24@0	see graph	PASS
77	30	10	636332	3544.98	DFT-s-OFDM BPSK	1@23	see graph	PASS
77	30	10	636332	3544.98	DFT-s-OFDM QPSK	1@23	see graph	PASS
77	30	10	636332	3544.98	DFT-s-OFDM BPSK	24@0	see graph	PASS
77	30	10	636332	3544.98	DFT-s-OFDM QPSK	24@0	see graph	PASS
77	30	50	631668	3475.02	DFT-s-OFDM BPSK	1@0	see graph	PASS
77	30	50	631668	3475.02	DFT-s-OFDM QPSK	1@0	see graph	PASS
77	30	50	631668	3475.02	DFT-s-OFDM BPSK	128@0	see graph	PASS
77	30	50	631668	3475.02	DFT-s-OFDM QPSK	128@0	see graph	PASS
77	30	50	635000	3525.0	DFT-s-OFDM BPSK	1@132	see graph	PASS
77	30	50	635000	3525.0	DFT-s-OFDM QPSK	1@132	see graph	PASS
77	30	50	635000	3525.0	DFT-s-OFDM BPSK	128@0	see graph	PASS
77	30	50	635000	3525.0	DFT-s-OFDM QPSK	128@0	see graph	PASS
77	30	100	633334	3500.01	DFT-s-OFDM BPSK	1@0	see graph	PASS
77	30	100	633334	3500.01	DFT-s-OFDM QPSK	1@0	see graph	PASS
77	30	100	633334	3500.01	DFT-s-OFDM BPSK	1@272	see graph	PASS
77	30	100	633334	3500.01	DFT-s-OFDM QPSK	1@272	see graph	PASS
77	30	100	633334	3500.01	DFT-s-OFDM BPSK	270@0	see graph	PASS
77	30	100	633334	3500.01	DFT-s-OFDM QPSK	270@0	see graph	PASS

N77(10M)\_DFT-s-  
OFDM\_BPSK\_Edge\_1RB\_Left\_Low\_CH

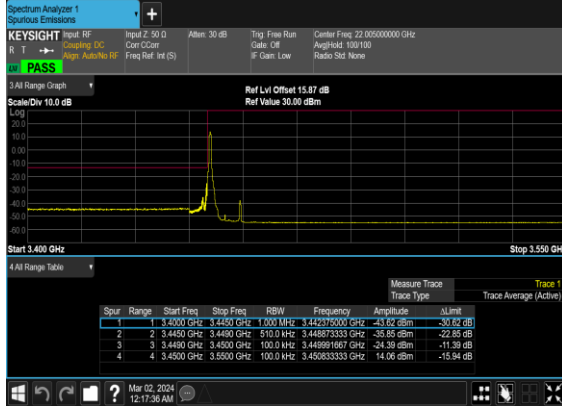

N77(10M)\_DFT-s-  
OFDM\_QPSK\_Edge\_1RB\_Left\_Low\_CH

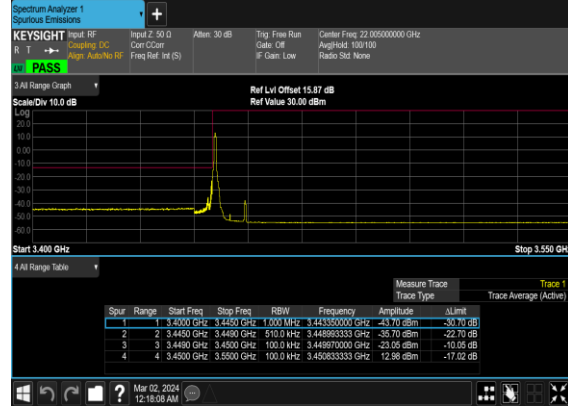

N77(10M)\_DFT-s-  
OFDM\_BPSK\_Outer\_Full\_Low\_CH

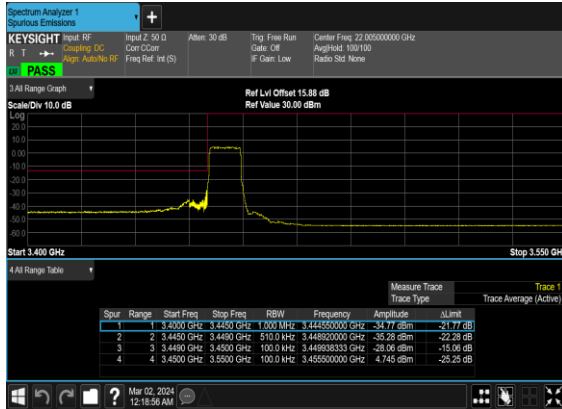

N77(10M)\_DFT-s-  
OFDM\_QPSK\_Outer\_Full\_Low\_CH

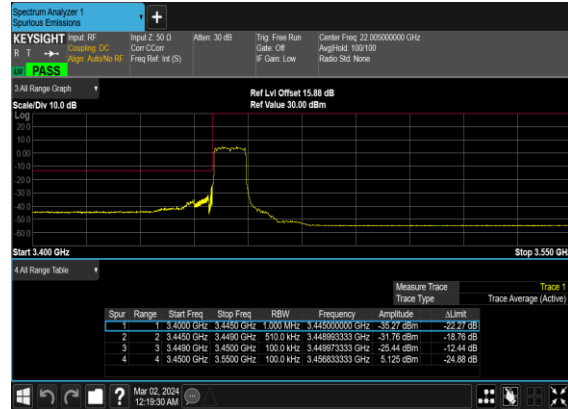

N77(10M)\_DFT-s-  
OFDM\_BPSK\_Edge\_1RB\_Right\_High\_CH

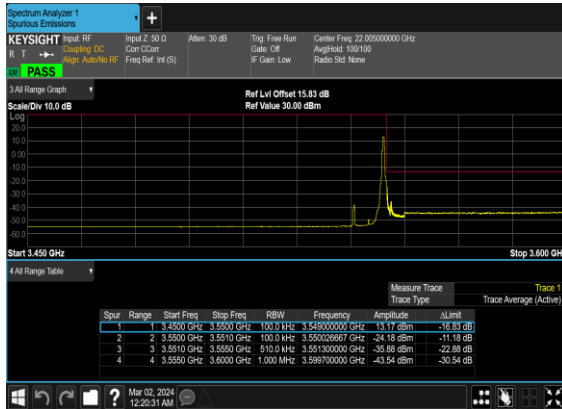

N77(10M)\_DFT-s-  
OFDM\_QPSK\_Edge\_1RB\_Right\_High\_CH

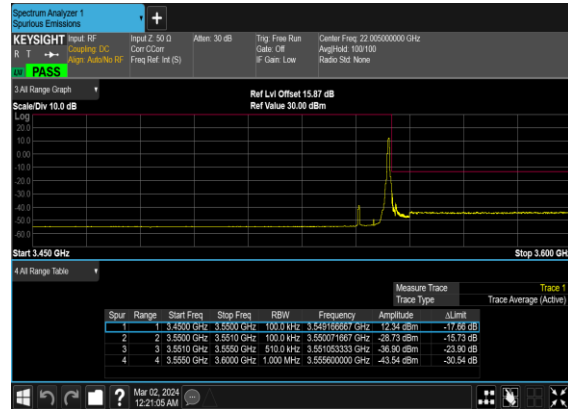

### N77(10M)\_DFT-s-OFDM\_BPSK\_Outer\_Full\_High\_CH

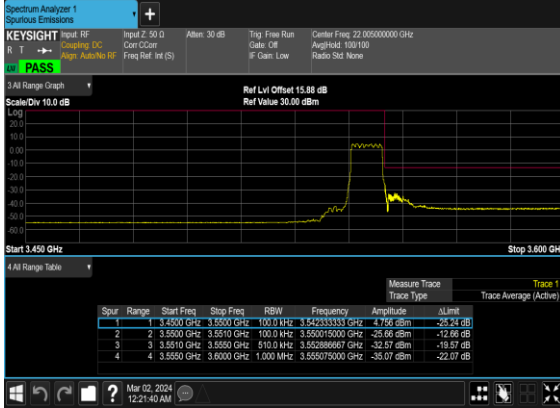

### N77(10M)\_DFT-s-OFDM\_QPSK\_Outer\_Full\_High\_CH

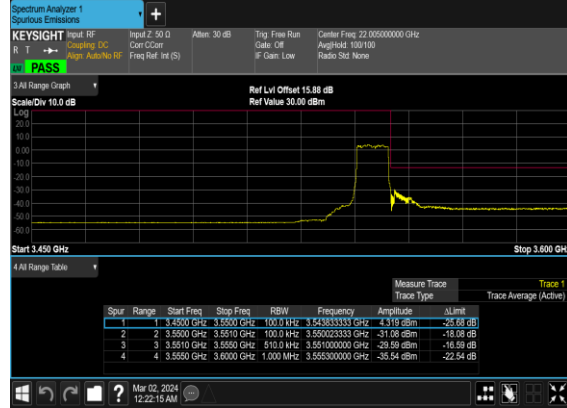

### N77(50M)\_DFT-s-OFDM\_BPSK\_Edge\_1RB\_Left\_Low\_CH

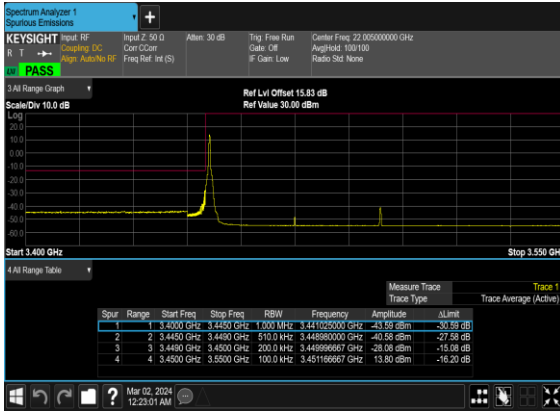

### N77(50M)\_DFT-s-OFDM\_QPSK\_Edge\_1RB\_Left\_Low\_CH



### N77(50M)\_DFT-s-OFDM\_BPSK\_Outer\_Full\_Low\_CH

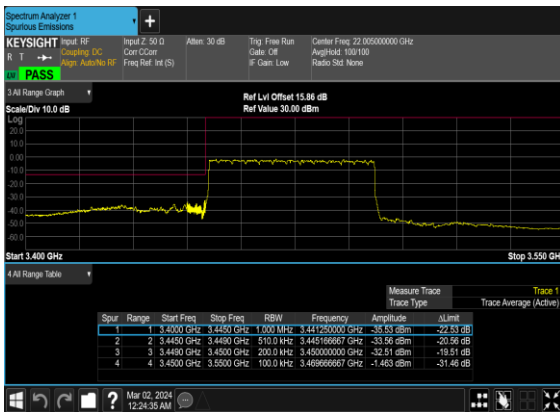

### N77(50M)\_DFT-s-OFDM\_QPSK\_Outer\_Full\_Low\_CH

