



FCC RF Test Report

APPLICANT : Motorola Mobility LLC
EQUIPMENT : Mobile Cellular Phone
BRAND NAME : Motorola
MODEL NAME : XT2343-1
FCC ID : IHDT56AM4
STANDARD : 47 CFR Part 2, Part 27 Subpart Q
CLASSIFICATION : PCS Licensed Transmitter Held to Ear (PCE)
TEST DATE(S) : Jun. 20, 2023 ~ Jul. 05, 2023

We, Sporton International Inc. (KunShan), would like to declare that the tested sample has been evaluated in accordance with the procedures given in ANSI C63.26-2015 and shown compliance with the applicable technical standards.

The test results in this report apply exclusively to the tested model / sample. Without written approval of Sporton International Inc. (KunShan), the test report shall not be reproduced except in full.

Jason Jia



Approved by: Jason Jia

Sporton International Inc. (Kunshan)

No. 1098, Pengxi North Road, Kunshan Economic Development Zone Jiangsu Province 215300
People's Republic of China



TABLE OF CONTENTS

REVISION HISTORY..... 3
SUMMARY OF TEST RESULT 4
1 GENERAL DESCRIPTION 5
1.1 Applicant 5
1.2 Manufacturer 5
1.3 Product Feature of Equipment Under Test 5
1.4 Product Specification of Equipment Under Test 5
1.5 Modification of EUT 6
1.6 Specification of Accessory 6
1.7 Maximum EIRP Power and Emission Designator 7
1.8 Testing Site 8
1.9 Test Software 8
1.10 Applied Standards 8
2 TEST CONFIGURATION OF EQUIPMENT UNDER TEST 9
2.1 Test Mode 9
2.2 Connection Diagram of Test System 10
2.3 Support Unit used in test configuration and system 10
2.4 Measurement Results Explanation Example 10
2.5 Frequency List of Low/Middle/High Channels 11
3 CONDUCTED TEST ITEMS 13
3.1 Measuring Instruments 13
3.2 Test Setup 13
3.3 Test Result of Conducted Test 13
3.4 Conducted Output Power Measurement 14
3.5 Peak-to-Average Ratio 15
3.6 EIRP 16
3.7 Occupied Bandwidth 17
3.8 Conducted Band Edge Measurement 18
3.9 Conducted Spurious Emission Measurement 19
3.10 Frequency Stability Measurement 20
4 RADIATED TEST ITEMS 21
4.1 Measuring Instruments 21
4.2 Test Setup 21
4.3 Test Result of Radiated Test 22
4.4 Radiated Spurious Emission Measurement 23
5 LIST OF MEASURING EQUIPMENT 24
6 MEASUREMENT UNCERTAINTY 25
APPENDIX A. TEST RESULTS OF CONDUCTED TEST
APPENDIX B. TEST RESULTS OF RADIATED TEST
APPENDIX C. TEST SETUP PHOTOGRAPHS

SUMMARY OF TEST RESULT

Report Section	FCC Rule	Description	Limit	Result	Remark
3.4	§2.1046	Conducted Output Power	—	Report Only	-
3.5	§27.50 (k)(4)	Peak-to-Average Ratio	<13dB	PASS	
3.6	§27.50 (k)(3)	EIRP	EIRP < 1W (30dBm)	PASS	-
3.7	§2.1049	Occupied Bandwidth	—	Report Only	-
3.8	§2.1051 §27.53 (n)(2)	Conducted Band Edge Measurement	-13dBm/MHz	PASS	-
3.9	§2.1051 §27.53 (n)(2)	Conducted Spurious Emission	-13dBm/MHz	PASS	-
3.10	§2.1055 §27.54	Frequency Stability Temperature & Voltage	Within the band	PASS	-
4.4	§2.1053 §27.53 (n)(2)	Radiated Spurious Emission	-13dBm/MHz	PASS	Under limit 38.12 dB at 6900.00 MHz

Conformity Assessment Condition:

1. The test results (PASS/FAIL) with all measurement uncertainty excluded are presented against the regulation limits or in accordance with the requirements stipulated by the applicant/manufacturer who shall bear all the risks of non-compliance that may potentially occur if measurement uncertainty is taken into account.
2. The measurement uncertainty please refer to each test result in the section "Measurement Uncertainty"

Disclaimer:

The product specifications of the EUT presented in the test report that may affect the test assessments are declared by the manufacturer who shall take full responsibility for the authenticity.

1 General Description

1.1 Applicant

Motorola Mobility LLC
 222 W, Merchandise Mart Plaza, Chicago IL 60654 USA

1.2 Manufacturer

Motorola Mobility LLC
 222 W, Merchandise Mart Plaza, Chicago IL 60654 USA

1.3 Product Feature of Equipment Under Test

Product Feature	
Equipment	Mobile Cellular Phone
Brand Name	Motorola
Model Name	XT2343-1
FCC ID	IHDT56AM4
IMEI Code	Radiation: 352326290030496/352326290030504 Conducted: 352326290030298/352326290030306
HW Version	DVT2
SW Version	TTD33.32
EUT Stage	Identical Prototype

1.4 Product Specification of Equipment Under Test

Product Feature	
Tx/Rx Frequency	5G NR n78: 3450 MHz ~ 3550 MHz
SCS	15kHz, 30kHz
Bandwidth	n78(15kHz): 10 / 15 / 20 / 30 / 40 / 50MHz n78(30kHz): 10 / 15 / 20 / 30 / 40 / 50 / 60 / 70 / 80 / 90 / 100MHz
Antenna Gain	<Ant. 1> -3.7 dBi <Ant. 2> -3.5 dBi <Ant. 5> -3.71 dBi <Ant. 7> -5.6 dBi
Type of Modulation	CP-OFDM: QPSK / 16QAM / 64QAM / 256QAM DFT-s-OFDM: PI/2 BPSK / QPSK / 16QAM / 64QAM / 256QAM

Remark:

1. The maximum EIRP is calculated from max output power and max antenna gain, only the maximum EIRP of Ant.5 for n78 is shown in the report.
2. The device supports n78(1T4R) SRS resources on Antenna 1/2/5/7, only the test data of worst Antenna 5 is showed in the report according to the maximum power.
3. 5G NR n78 support SA and NSA mode. The whole testing has assessed SA mode for n78 by referring to the higher conducted power for conducted test items.

4. 5G NR n78 support SCS 15kHz and SCS 30kHz. According to the maximum power, n78 SCS 15kHz covers SCS 30kHz for BW 10/15/20/30/40/50MHz.
5. All the supported EN-DC combinations are verified conducted power, only the EN-DC combination with highest power are shown in the report.
6. The EN-DC mode combination could be referred to the product spec.

1.5 Modification of EUT

No modifications are made to the EUT during all test items.

1.6 Specification of Accessory

Specification of Accessory				
AC Adapter 1 (US)	Brand Name	Motorola(Salcomp)	Model Name	MC-201L
AC Adapter 1 (EU)	Brand Name	Motorola(Salcomp)	Model Name	MC-202L
AC Adapter 1 (AR)	Brand Name	Motorola(Salcomp)	Model Name	MC-206L
AC Adapter 1 (BR)	Brand Name	Motorola(Salcomp)	Model Name	MC-207L
AC Adapter 1 (CHILE)	Brand Name	Motorola(Salcomp)	Model Name	MC-209L
AC Adapter 2 (US)	Brand Name	Motorola(AOHAI)	Model Name	MC-201L
AC Adapter 2 (EU)	Brand Name	Motorola(AOHAI)	Model Name	MC-202L
AC Adapter 2 (AR)	Brand Name	Motorola(AOHAI)	Model Name	MC-206L
AC Adapter 3 (BR)	Brand Name	Motorola(Cliptech)	Model Name	MC-207L
AC Adapter 4 (BR)	Brand Name	Motorola(Chenyang)	Model Name	MC-207L
Battery 1	Brand Name	Motorola(ATL)	Model Name	PC50
Battery 2	Brand Name	Motorola (SCUD)	Model Name	PC50
USB Cable 1	Brand Name	Motorola (WASHIN)	Model Name	S928D92375
USB Cable 2	Brand Name	Motorola (Saibao)	Model Name	S928D95755
USB Cable 3	Brand Name	Motorola (ISHENG)	Model Name	SC18D38574

1.7 Maximum EIRP Power and Emission Designator

5G NR n78 SCS 15kHz / Ant.5		PI/2 BPSK / QPSK		16QAM/64QAM/256QAM	
BW (MHz)	Frequency Range (MHz)	Maximum EIRP(W)	Emission Designator (99%OBW)	Maximum EIRP(W)	Emission Designator (99%OBW)
10	3455.01 ~ 3544.995	0.0766	9M26G7D	0.0589	9M27W7D
15	3457.50 ~ 3542.49	0.0793	14M1G7D	0.0615	14M1W7D
20	3460.005 ~ 3540.00	0.0793	18M9G7D	0.0605	18M9W7D
30	3465.00 ~ 3534.99	0.0764	28M6G7D	0.0579	28M6W7D
40	3470.01 ~ 3529.995	0.0726	38M5G7D	0.0557	38M5W7D
50	3475.005 ~ 3525.00	0.0815	48M1G7D	0.0643	48M2W7D
5G NR n78 SCS 30kHz / Ant.5		PI/2 BPSK / QPSK		16QAM/64QAM/256QAM	
BW (MHz)	Frequency Range (MHz)	Maximum EIRP(W)	Emission Designator (99%OBW)	Maximum EIRP(W)	Emission Designator (99%OBW)
60	3480.00 ~ 3519.99	0.0764	57M8G7D	0.0592	57M8W7D
70	3485.01 ~ 3514.98	0.0753	67M4G7D	0.0590	67M6W7D
80	3490.02 ~ 3510.00	0.0745	77M4G7D	0.0582	77M5W7D
90	3495.00 ~ 3504.99	0.0731	87M3G7D	0.0566	87M3W7D
100	3500.01	0.0783	97M2G7D	0.0622	97M3W7D

Note: All modulations have been tested, and only the worst test results of PSK & QAM are shown in the report.

1.8 Testing Site

Sporton International Inc. (Kunshan) is accredited to ISO/IEC 17025:2017 by American Association for Laboratory Accreditation with Certificate Number 5145.02.

Test Firm	Sporton International Inc. (Kunshan)		
Test Site Location	No. 1098, Pengxi North Road, Kunshan Economic Development Zone Jiangsu Province 215300 People's Republic of China TEL : +86-512-57900158		
Test Site No.	Sporton Site No.	FCC Designation No.	FCC Test Firm Registration No.
	03CH04-KS TH01-KS	CN1257	314309

1.9 Test Software

Item	Site	Manufacturer	Name	Version
1.	03CH04-KS	AUDIX	E3	6.2009-8-24al

1.10 Applied Standards

According to the specifications of the manufacturer, the EUT must comply with the requirements of the following standards:

- ♦ 47 CFR Part 2, Part 27 Subpart Q
- ♦ ANSI C63.26-2015
- ♦ FCC KDB 971168 Power Meas License Digital Systems D01 v03r01
- ♦ FCC KDB 412172 D01 Determining ERP and EIRP v01r01

Remark:

1. All test items were verified and recorded according to the standards and without any deviation during the test.
2. This EUT has also been tested and complied with the requirements of FCC Part 15, Subpart B, recorded in a separate test report.



2 Test Configuration of Equipment Under Test

2.1 Test Mode

Antenna port conducted and radiated test items listed below are performed according to KDB 971168 D01 Power Meas. License Digital Systems v03r01 with maximum output power.

Radiated measurements are performed by rotating the EUT in three different orthogonal test planes to find the maximum emission.

Test Items	5G NR	Bandwidth (MHz)													Modulation					RB #		Test Channel				
		5	10	15	20	25	30	40	50	60	70	80	90	100	PI/2 BPSK	QPSK	16 QAM	64 QAM	256 QAM	1	Full	L	M	H		
Max. Output Power	n78	-	v	v	v	-	v	v	v	v	v	v	v	v	v	v	v	v	v	v	v	v	v	v	v	v
Peak-to-Average Ratio	n78 15K	-				-			v						v	v				v	v			v		
	n78 30K	-				-							v	v	v	v				v	v			v		
26dB and 99% Bandwidth	n78 15K	-	v	v	v	-	v	v	v						v	v	v	v	v		v			v		
	n78 30K	-				-				v	v	v	v	v	v	v	v	v	v		v			v		
Conducted Band Edge	n78 15K	-	v			-	v		v						v	v				v	v	v			v	
	n78 30K	-				-				v		v		v	v	v				v	v	v			v	
Conducted Spurious Emission	n78 15K	-	v			-	v		v						v	v				v		v	v	v	v	v
	n78 30K	-				-				v		v		v	v	v				v		v	v	v	v	v
Frequency Stability	n78 15K	-	v			-										v					v		v			
	n78 30K	-				-								v		v					v		v			
E.I.R.P	n78	-	v	v	v	-	v	v	v	v	v	v	v	v	v	v	v	v	v	v	v	v	v	v	v	v
Radiated Spurious Emission	n78	Worst Case																					v			
Note	<ol style="list-style-type: none"> The mark "v" means that this configuration is chosen for testing The mark "-" means that this bandwidth is not supported. The device is investigated from 30MHz to 10 times of fundamental signal for radiated spurious emission test under different RB size/offset and modulations in exploratory test. Subsequently, only the worst case emissions are reported. Frequency Stability : Normal Voltage = 3.91V ; Low Voltage =3.60V. ; High Voltage =4.45V 																									

2.2 Connection Diagram of Test System

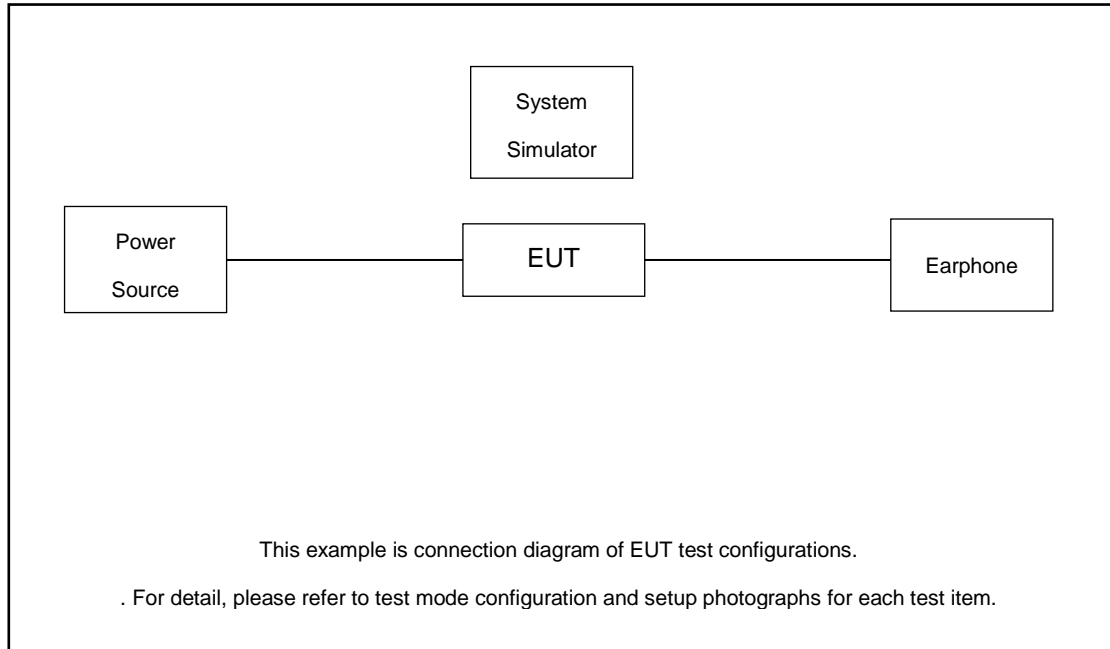

2.3 Support Unit used in test configuration and system

Item	Equipment	Trade Name	Model No.	FCC ID	Data Cable	Power Cord
1.	Power Supply	GWINSTEK	PSS-2002	N/A	N/A	Unshielded, 1.8 m
2.	LTE Base Station	Anritsu	MT8820C	N/A	N/A	Unshielded, 1.8 m
3.	NR Base Station	Anritsu	MT8000A	N/A	N/A	Unshielded, 1.8 m

2.4 Measurement Results Explanation Example

For all conducted test items:

The offset level is set in the spectrum analyzer to compensate the RF cable loss and attenuator factor between EUT conducted output port and spectrum analyzer. With the offset compensation, the spectrum analyzer reading level is exactly the EUT RF output level.

The spectrum analyzer offset is derived from RF cable loss and attenuator factor.

Offset = RF cable loss + attenuator factor.

Following shows an offset computation example with cable loss 3.49 dB and 10dB attenuator.

Example :

$$\begin{aligned} \text{Offset(dB)} &= \text{RF cable loss(dB)} + \text{attenuator factor(dB)}. \\ &= 3.49 + 10 = 13.49 \text{ (dB)} \end{aligned}$$

2.5 Frequency List of Low/Middle/High Channels

5G n78 Channel and Frequency List for SCS 15kHz				
BW [MHz]	Channel/Frequency(MHz)	Lowest	Middle	Highest
50	Channel	631667	633334	635000
	Frequency	3475.005	3500.01	3525
40	Channel	631334	633334	635333
	Frequency	3470.01	3500.01	3529.995
30	Channel	631000	633334	635666
	Frequency	3465	3500.01	3534.99
20	Channel	630667	633334	636000
	Frequency	3460.005	3500.01	3540
15	Channel	630500	633334	636166
	Frequency	3457.5	3500.01	3542.49
10	Channel	630334	633334	636333
	Frequency	3455.01	3500.01	3544.995

5G n78 Channel and Frequency List for SCS 30kHz				
BW [MHz]	Channel/Frequency(MHz)	Lowest	Middle	Highest
100	Channel	-	633334	-
	Frequency	-	3500.01	-
90	Channel	633000	633334	633666
	Frequency	3495	3500.01	3504.99
80	Channel	632668	633334	634000
	Frequency	3490.02	3500.01	3510
70	Channel	632334	633334	634332
	Frequency	3485.01	3500.01	3514.98
60	Channel	632000	633334	634666
	Frequency	3480	3500.01	3519.99
50	Channel	631668	633334	635000
	Frequency	3475.02	3500.01	3525
40	Channel	631334	633334	635332
	Frequency	3470.01	3500.01	3529.98
30	Channel	631000	633334	635666
	Frequency	3465	3500.01	3534.99



20	Channel	630668	633334	636000
	Frequency	3460.02	3500.01	3540
15	Channel	630500	633334	636166
	Frequency	3457.5	3500.01	3542.49
10	Channel	630334	633334	636332
	Frequency	3455.01	3500.01	3544.98

3 Conducted Test Items

3.1 Measuring Instruments

See list of measuring instruments of this test report.

3.2 Test Setup

3.2.1 Conducted Output Power

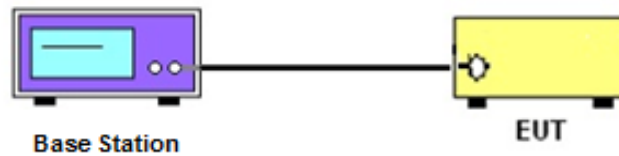

3.2.2 Peak-to-Average Ratio, Occupied / 26dB Bandwidth, Band-Edge and Conducted Spurious Emission

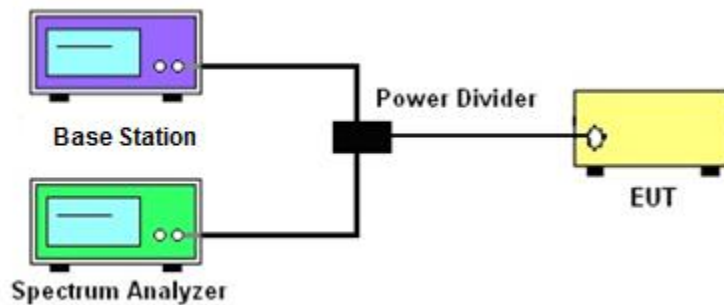

3.2.3 Frequency Stability

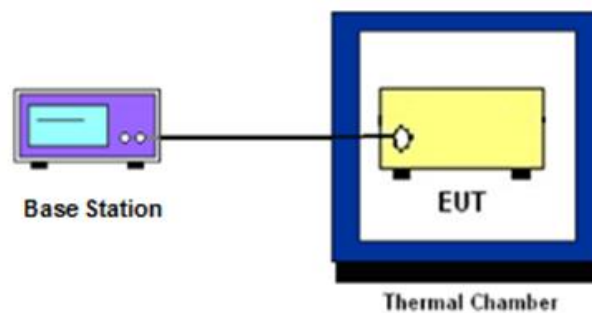

3.3 Test Result of Conducted Test

Please refer to Appendix A.

3.4 Conducted Output Power Measurement

3.4.1 Description of the Conducted Output Power Measurement

A base station simulator was used to establish communication with the EUT. Its parameters were set to transmit the maximum power on the EUT. The measured power in the radio frequency on the transmitter output terminals shall be reported.

3.4.2 Test Procedures

1. The testing follows ANSI C63.26 Section 5.2
2. The transmitter output port was connected to the system simulator.
3. Set EUT at maximum power through the system simulator.
4. Select lowest, middle, and highest channels for each band and different modulation.
5. Measure and record the power level from the system simulator.

3.5 Peak-to-Average Ratio

3.5.1 Description of the PAR Measurement

Power Complementary Cumulative Distribution Function (CCDF) curves provide a means for characterizing the power peaks of a digitally modulated signal on a statistical basis. A CCDF curve depicts the probability of the peak signal amplitude exceeding the average power level. Most contemporary measurement instrumentation include the capability to produce CCDF curves for an input signal provided that the instrument's resolution bandwidth can be set wide enough to accommodate the entire input signal bandwidth. In measuring transmissions in this band using an average power technique, the peak-to-average ratio (PAR) of the transmission may not exceed 13 dB.

3.5.2 Test Procedures

1. The testing follows ANSI C63.26 Section 5.2.3.4 (CCDF).
2. The EUT was connected to spectrum and system simulator via a power divider.
3. Set the CCDF (Complementary Cumulative Distribution Function) option in spectrum analyzer.
4. The highest RF powers were measured and recorded the maximum PAPR level associated with a probability of 0.1 %.
5. Record the deviation as Peak to Average Ratio.

3.6 EIRP

3.6.1 Description of EIRP Limit

§ 27.50 (k)(3)

Mobile devices are limited to 1Watt (30 dBm) EIRP. Mobile devices operating in these bands must employ a means for limiting power to the minimum necessary for successful communications

3.6.2 Test Procedures

1. According to KDB 412172 D01 Power Approach,
2. $EIRP = P_T + G_T - L_C$, $ERP = EIRP - 2.15$, where
 P_T = transmitter output power in dBm
 G_T = gain of the transmitting antenna in dBi
 L_C = signal attenuation in the connecting cable between the transmitter and antenna in dB

3.7 Occupied Bandwidth

3.7.1 Description of Occupied Bandwidth Measurement

The occupied bandwidth is the width of a frequency band such that, below the lower and above the upper frequency limits, the mean powers emitted are each equal to a specified percentage 0.5% of the total mean transmitted power.

The 26 dB emission bandwidth is defined as the frequency range between two points, one above and one below the carrier frequency, at which the spectral density of the emission is attenuated 26 dB below the maximum in-band spectral density of the modulated signal. Spectral density (power per unit bandwidth) is to be measured with a detector of resolution bandwidth equal to approximately 1.0% of the emission bandwidth.

3.7.2 Test Procedures

1. The testing follows ANSI C63.26 Section 5.4
2. The EUT was connected to spectrum analyzer and system simulator via a power divider.
3. The spectrum analyzer center frequency is set to the nominal EUT channel center frequency. The span range for the spectrum analyzer shall be between two and five times the anticipated OBW.
4. The nominal resolution bandwidth (RBW) shall be in the range of 1 to 5 % of the anticipated OBW, and the VBW shall be at least 3 times the RBW.
5. Set the detection mode to peak, and the trace mode to max hold.
6. Determine the reference value: Set the EUT to transmit a modulated signal. Allow the trace to stabilize. Set the spectrum analyzer marker to the highest level of the displayed trace.
(this is the reference value)
7. Determine the “-26 dB down amplitude” as equal to (Reference Value – X).
8. Place two markers, one at the lowest and the other at the highest frequency of the envelope of the spectral display such that each marker is at or slightly below the “-X dB down amplitude” determined in step 6. If a marker is below this “-X dB down amplitude” value it shall be placed as close as possible to this value. The OBW is the positive frequency difference between the two markers.
9. Use the 99 % power bandwidth function of the spectrum analyzer and report the measured bandwidth.

3.8 Conducted Band Edge Measurement

3.8.1 Description of Conducted Band Edge Measurement

§ 27.53 (n)(2)

For mobile operations in the 3450-3550 MHz band, the conducted power of any emission outside the licensee's authorized bandwidth shall not exceed -13 dBm/MHz.

Compliance with this paragraph is based on the use of measurement instrumentation employing a resolution bandwidth of 1 megahertz or greater. However, in the 1 megahertz bands immediately outside and adjacent to the licensee's frequency block, a resolution bandwidth of at least one percent of the emission bandwidth of the fundamental emission of the transmitter may be employed, but limited to a maximum of 200 kHz. In the bands between 1 and 5 MHz removed from the licensee's frequency block, the minimum resolution bandwidth for the measurement shall be 500 kHz.

3.8.2 Test Procedures

1. The testing follows ANSI C63.26 section 5.7
2. The EUT was connected to spectrum analyzer and system simulator via a power divider.
3. The band edges of low and high channels for the highest RF powers were measured.
4. Set RBW $\geq 1\%$ EBW but limited to a maximum of 200 kHz in the 1MHz band immediately outside and adjacent to the band edge.
5. Beyond the 1 MHz and 5 MHz removed from the band edge, set RBW ≥ 500 KHz.
6. Beyond the 5 MHz removed from the band edge, set RBW = 1MHz.
7. Set spectrum analyzer with RMS detector.
8. The RF fundamental frequency should be excluded against the limit line in the operating frequency band.
9. Checked that all the results comply with the emission limit line.

3.9 Conducted Spurious Emission Measurement

3.9.1 Description of Conducted Spurious Emission Measurement

The power of any emission outside of the authorized operating frequency ranges shall not exceed -13 dBm/MHz.

It is measured by means of a calibrated spectrum analyzer and scanned from 9 kHz up to a frequency including its 10th harmonic.

3.9.2 Test Procedures

1. The testing follows ANSI C63.26 section 5.7
2. The EUT was connected to spectrum analyzer and system simulator via a power divider.
3. The RF output of EUT was connected to the spectrum analyzer by RF cable and attenuator. The path loss was compensated to the results for each measurement.
4. The middle channel for the highest RF power within the transmitting frequency was measured.
5. The conducted spurious emission for the whole frequency range was taken.
6. Make the measurement with the spectrum analyzer's RBW = 1MHz, VBW = 3MHz.
7. Set spectrum analyzer with RMS detector.
8. Taking the record of maximum spurious emission.
9. The RF fundamental frequency should be excluded against the limit line in the operating frequency band.
10. Checked that all the results comply with the emission limit line.

3.10 Frequency Stability Measurement

3.10.1 Description of Frequency Stability Measurement

The frequency stability shall be measured by variation of ambient temperature and variation of primary supply voltage to ensure that the fundamental emission stays within the authorized frequency block.

3.10.2 Test Procedures for Temperature Variation

1. The testing follows ANSI C63.26 section 5.6.4
2. The EUT was set up in the thermal chamber and connected with the system simulator.
3. With power OFF, the temperature was decreased to -30°C and the EUT was stabilized before testing. Power was applied and the maximum change in frequency was recorded within one minute.
4. With power OFF, the temperature was raised in 10°C step up to 50°C . The EUT was stabilized at each step for at least half an hour. Power was applied and the maximum frequency change was recorded within one minute.

3.10.3 Test Procedures for Voltage Variation

1. The testing follows ANSI C63.26 section 5.6.5.
2. The EUT was placed in a temperature chamber at $20\pm 5^{\circ}\text{C}$ and connected with the system simulator.
3. The power supply voltage to the EUT was varied from 85% to 115% of the nominal value for other than hand carried battery equipment.
4. For hand carried, battery powered equipment, reduce the primary ac or dc supply voltage to the battery operating end point, which shall be specified by the manufacturer.
5. The variation in frequency was measured for the worst case.

4 Radiated Test Items

4.1 Measuring Instruments

See list of measuring instruments of this test report.

4.2 Test Setup

4.2.1 For radiated test below 30MHz

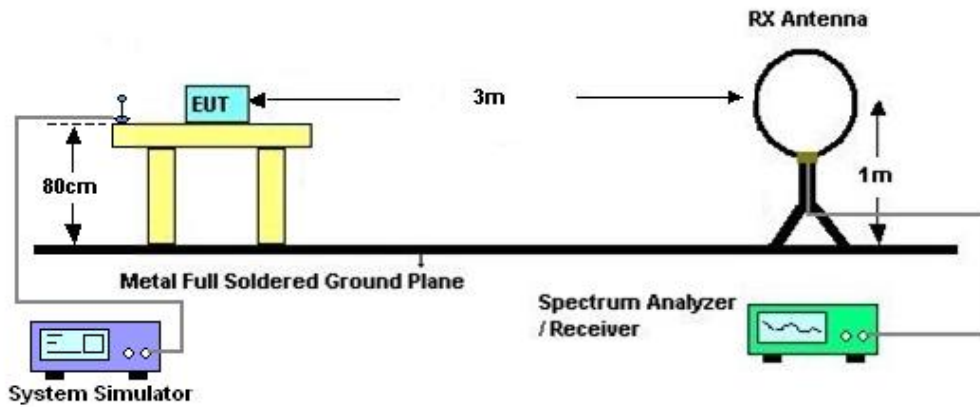

4.2.2 For radiated test from 30MHz to 1GHz

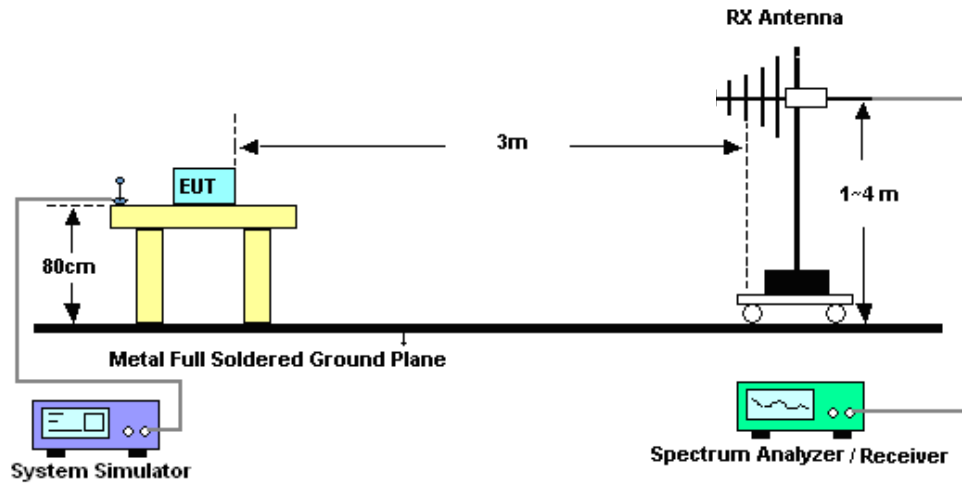

4.2.3 For radiated test above 1GHz

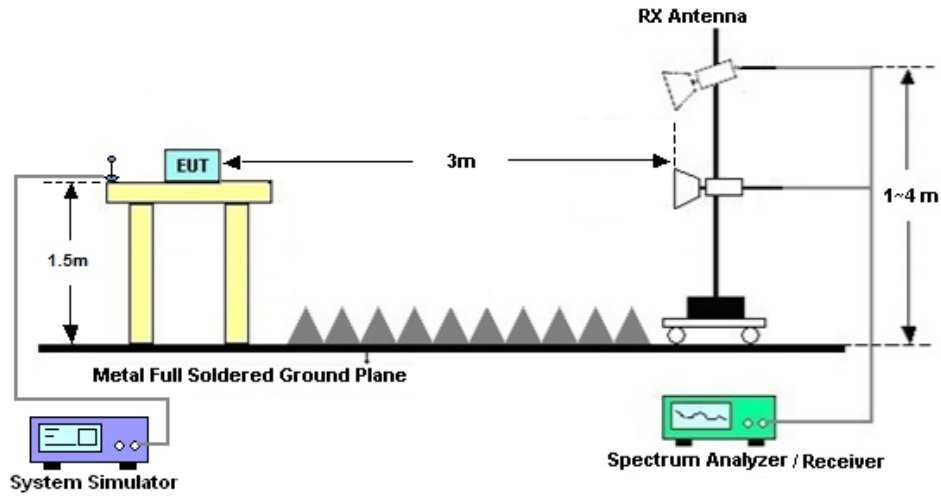

4.3 Test Result of Radiated Test

The low frequency, which started from 9 kHz to 30MHz, was pre-scanned and the result which was 20dB lower than the limit line was not reported.

Please refer to Appendix B.

4.4 Radiated Spurious Emission Measurement

4.4.1 Description of Radiated Spurious Emission

The radiated spurious emission was measured by substitution method according to ANSI/TIA-603-E. The power of any emission outside of the authorized operating frequency ranges shall not exceed -13 dBm/MHz.

The spectrum is scanned from 30 MHz up to a frequency including its 10th harmonic.

4.4.2 Test Procedures

1. The testing follows ANSI C63.26 Section 5.5
2. The EUT was placed on a turntable with 0.8 meter height for frequency below 1GHz and 1.5 meter height for frequency above 1GHz respectively above ground.
3. The EUT was set 3 meters from the receiving antenna mounted on the antenna tower.
4. The table was rotated 360 degrees to determine the position of the highest spurious emission.
5. The height of the receiving antenna is varied between 1m to 4m to search the maximum spurious emission for both horizontal and vertical polarizations.
6. During the measurement, the system simulator parameters were set to force the EUT transmitting at maximum output power.
7. Make the measurement with the spectrum analyzer's RBW = 1MHz, VBW = 3MHz, taking the record of maximum spurious emission.
8. A horn antenna was substituted in place of the EUT and was driven by a signal generator.
9. Tune the output power of signal generator to the same emission level with EUT maximum spurious emission.
$$\text{EIRP (dBm)} = \text{S.G. Power} - \text{Tx Cable Loss} + \text{Tx Antenna Gain}$$
$$\text{ERP (dBm)} = \text{EIRP} - 2.15$$
10. The RF fundamental frequency should be excluded against the limit line in the operating frequency band.



5 List of Measuring Equipment

Instrument	Manufacturer	Model No.	Serial No.	Characteristics	Calibration Date	Test Date	Due Date	Remark
Spectrum Analyzer	R&S	FSV40	101040	10Hz~40GHz	Oct. 12, 2022	Jun. 20, 2023~ Jul. 05, 2023	Oct. 11, 2023	Conducted (TH01-KS)
Power divider	STI	STI08-0055	-	0.5~40GHz	/	Jun. 20, 2023~ Jul. 05, 2023	/	Conducted (TH01-KS)
Temperature & humidity chamber	Hongzhan	LP-150U	H201401144 0	-40~+150°C 20%~95%RH	Jul. 15, 2022	Jun. 20, 2023~ Jul. 05, 2023	Jul. 14, 2023	Conducted (TH01-KS)
EXA Spectrum Analyzer	Keysight	N9010B	MY5747107 9	10Hz~44G,MAX 30dB	Oct. 12, 2022	Jun. 27, 2023	Oct. 11, 2023	Radiation (03CH04-KS)
Loop Antenna	R&S	HFH2-Z2	100321	9kHz~30MHz	Oct. 16, 2022	Jun. 27, 2023	Oct. 15, 2023	Radiation (03CH04-KS)
Bilog Antenna	TeseQ	CBL6111D	49922	30MHz~1GHz	Apr. 09, 2023	Jun. 27, 2023	Apr. 08, 2024	Radiation (03CH04-KS)
Horn Antenna	Schwarzbeck	BBHA9120 D	1284	1GHz~18GHz	Oct. 16, 2022	Jun. 27, 2023	Oct. 15, 2023	Radiation (03CH04-KS)
SHF-EHF Horn	Com-power	AH-840	101070	18GHz~40GHz	Jan. 08, 2023	Jun. 27, 2023	Jan. 07, 2024	Radiation (03CH04-KS)
Amplifier	SONOMA	310N	380827	9KHz~1GHz	Jul. 11, 2022	Jun. 27, 2023	Jul. 10, 2023	Radiation (03CH04-KS)
Amplifier	MITEQ	EM18G40G GA	060728	18~40GHz	Jan. 05, 2023	Jun. 27, 2023	Jan. 04, 2024	Radiation (03CH04-KS)
high gain Amplifier	EM	EM01G18G A	060840	1Ghz~18Ghz	Oct. 12, 2022	Jun. 27, 2023	Oct. 11, 2023	Radiation (03CH04-KS)
Amplifier	Agilent	8449B	3008A02370	1Ghz~18Ghz	Oct. 12, 2022	Jun. 27, 2023	Oct. 11, 2023	Radiation (03CH04-KS)
AC Power Source	Chroma	61601	F104090004	N/A	NCR	Jun. 27, 2023	NCR	Radiation (03CH04-KS)
Turn Table	ChamPro	EM 1000-T	060762-T	0~360 degree	NCR	Jun. 27, 2023	NCR	Radiation (03CH04-KS)
Antenna Mast	ChamPro	EM 1000-A	060762-A	1 m~4 m	NCR	Jun. 27, 2023	NCR	Radiation (03CH04-KS)

NCR: No Calibration Required

6 Measurement Uncertainty

The measurement uncertainties shown below were calculated in accordance with the requirements of ANSI 63.26-2015. All the measurement uncertainty value were shown with a coverage K=2 to indicate 95% level of confidence. The measurement data show herein meets or exceeds the CISPR measurement uncertainty values specified in CISPR 16-4-2 and can be compared directly to specified limit to determine compliance.

Uncertainty of Conducted Measurement

Test Item	Uncertainty
Conducted Power	±0.46 dB
Conducted Emissions	±2.26 dB
Occupied Channel Bandwidth	±0.1 %

Uncertainty of Radiated Emission Measurement (30 MHz ~ 1000 MHz)

Measuring Uncertainty for a Level of Confidence of 95% (U = 2Uc(y))	3.82dB
---------------------------------------------------------------------	--------

Uncertainty of Radiated Emission Measurement (1 GHz ~ 18 GHz)

Measuring Uncertainty for a Level of Confidence of 95% (U = 2Uc(y))	3.56dB
---------------------------------------------------------------------	--------

Uncertainty of Radiated Emission Measurement (18 GHz ~ 40 GHz)

Measuring Uncertainty for a Level of Confidence of 95% (U = 2Uc(y))	3.54dB
---------------------------------------------------------------------	--------

----- THE END -----



Appendix A. Test Results of Conducted Test

Test Engineer :	Simle Wang	Temperature :	22~23°C
		Relative Humidity :	40~42%

FR1 N78(ANT5)

Transmitter Conducted Output Power And EIRP, (G_T - L_C)=-3.71dB

NR Band	SCS	Band Width	Arfcn	Freq(MHz)	Modulation	RB	Conducted Power(dBm)	EIRP(dBm)	EIRP(W)
78	15	10	630334	3455.01	DFT-s-OFDM PI/2 BPSK	1@1	22.48	18.77	0.0753
78	15	10	630334	3455.01	DFT-s-OFDM QPSK	1@1	22.45	18.74	0.0748
78	15	10	630334	3455.01	DFT-s-OFDM 16 QAM	1@1	21.41	17.7	0.0589
78	15	10	633334	3500.01	DFT-s-OFDM PI/2 BPSK	1@1	22.46	18.75	0.0750
78	15	10	633334	3500.01	DFT-s-OFDM QPSK	1@1	22.49	18.78	0.0755
78	15	10	633334	3500.01	DFT-s-OFDM 16 QAM	1@1	21.31	17.6	0.0575
78	15	10	636333	3544.995	DFT-s-OFDM PI/2 BPSK	1@1	22.55	18.84	0.0766
78	15	10	636333	3544.995	DFT-s-OFDM QPSK	1@1	22.5	18.79	0.0757
78	15	10	636333	3544.995	DFT-s-OFDM 16 QAM	1@1	21.18	17.47	0.0558
78	15	15	630500	3457.5	DFT-s-OFDM PI/2 BPSK	1@1	22.56	18.85	0.0767
78	15	15	630500	3457.5	DFT-s-OFDM QPSK	1@1	22.61	18.9	0.0776
78	15	15	630500	3457.5	DFT-s-OFDM 16 QAM	1@1	21.52	17.81	0.0604
78	15	15	633334	3500.01	DFT-s-OFDM PI/2 BPSK	1@1	22.51	18.8	0.0759
78	15	15	633334	3500.01	DFT-s-OFDM QPSK	1@1	22.58	18.87	0.0771
78	15	15	633334	3500.01	DFT-s-OFDM 16 QAM	1@1	21.5	17.79	0.0601
78	15	15	636166	3542.49	DFT-s-OFDM PI/2 BPSK	1@1	22.61	18.9	0.0776
78	15	15	636166	3542.49	DFT-s-OFDM QPSK	1@1	22.7	18.99	0.0793
78	15	15	636166	3542.49	DFT-s-OFDM 16 QAM	1@1	21.6	17.89	0.0615
78	15	20	630667	3460.005	DFT-s-OFDM PI/2 BPSK	1@1	22.57	18.86	0.0769
78	15	20	630667	3460.005	DFT-s-OFDM QPSK	1@1	22.57	18.86	0.0769
78	15	20	630667	3460.005	DFT-s-OFDM 16 QAM	1@1	21.53	17.82	0.0605
78	15	20	633334	3500.01	DFT-s-OFDM PI/2 BPSK	1@1	22.51	18.8	0.0759
78	15	20	633334	3500.01	DFT-s-OFDM QPSK	1@1	22.5	18.79	0.0757
78	15	20	633334	3500.01	DFT-s-OFDM 16 QAM	1@1	21.46	17.75	0.0596
78	15	20	636000	3540	DFT-s-OFDM PI/2 BPSK	1@1	22.62	18.91	0.0778
78	15	20	636000	3540	DFT-s-OFDM QPSK	1@1	22.7	18.99	0.0793
78	15	20	636000	3540	DFT-s-OFDM 16 QAM	1@1	21.53	17.82	0.0605
78	15	30	631000	3465	DFT-s-OFDM PI/2 BPSK	1@1	22.44	18.73	0.0746

78	15	30	631000	3465	DFT-s-OFDM QPSK	1@1	22.43	18.72	0.0745
78	15	30	631000	3465	DFT-s-OFDM 16 QAM	1@1	21.3	17.59	0.0574
78	15	30	633334	3500.01	DFT-s-OFDM PI/2 BPSK	1@1	22.36	18.65	0.0733
78	15	30	633334	3500.01	DFT-s-OFDM QPSK	1@1	22.4	18.69	0.0740
78	15	30	633334	3500.01	DFT-s-OFDM 16 QAM	1@1	21.24	17.53	0.0566
78	15	30	635666	3534.99	DFT-s-OFDM PI/2 BPSK	1@1	22.52	18.81	0.0760
78	15	30	635666	3534.99	DFT-s-OFDM QPSK	1@1	22.54	18.83	0.0764
78	15	30	635666	3534.99	DFT-s-OFDM 16 QAM	1@1	21.34	17.63	0.0579
78	15	40	631334	3470.01	DFT-s-OFDM PI/2 BPSK	1@1	22.14	18.43	0.0697
78	15	40	631334	3470.01	DFT-s-OFDM QPSK	1@1	22.2	18.49	0.0706
78	15	40	631334	3470.01	DFT-s-OFDM 16 QAM	1@1	21.1	17.39	0.0548
78	15	40	633334	3500.01	DFT-s-OFDM PI/2 BPSK	1@1	22.11	18.4	0.0692
78	15	40	633334	3500.01	DFT-s-OFDM QPSK	1@1	22.13	18.42	0.0695
78	15	40	633334	3500.01	DFT-s-OFDM 16 QAM	1@1	21.05	17.34	0.0542
78	15	40	635333	3529.995	DFT-s-OFDM PI/2 BPSK	1@1	22.25	18.54	0.0714
78	15	40	635333	3529.995	DFT-s-OFDM QPSK	1@1	22.32	18.61	0.0726
78	15	40	635333	3529.995	DFT-s-OFDM 16 QAM	1@1	21.17	17.46	0.0557
78	15	50	631667	3475.005	DFT-s-OFDM PI/2 BPSK	135@ 67	22.69	18.98	0.0791
78	15	50	631667	3475.005	DFT-s-OFDM PI/2 BPSK	1@1	22.52	18.81	0.0760
78	15	50	631667	3475.005	DFT-s-OFDM PI/2 BPSK	1@26 8	22.41	18.7	0.0741
78	15	50	631667	3475.005	DFT-s-OFDM QPSK	135@ 67	22.7	18.99	0.0793
78	15	50	631667	3475.005	DFT-s-OFDM QPSK	1@1	22.6	18.89	0.0774
78	15	50	631667	3475.005	DFT-s-OFDM QPSK	1@26 8	22.4	18.69	0.0740
78	15	50	631667	3475.005	DFT-s-OFDM 16 QAM	135@ 67	21.62	17.91	0.0618
78	15	50	631667	3475.005	DFT-s-OFDM 16 QAM	1@1	21.53	17.82	0.0605
78	15	50	631667	3475.005	DFT-s-OFDM 16 QAM	1@26 8	21.41	17.7	0.0589
78	15	50	631667	3475.005	DFT-s-OFDM 64 QAM	135@ 67	20.16	16.45	0.0442
78	15	50	631667	3475.005	DFT-s-OFDM 64 QAM	1@1	20.12	16.41	0.0438
78	15	50	631667	3475.005	DFT-s-OFDM 64 QAM	1@26 8	20	16.29	0.0426
78	15	50	631667	3475.005	DFT-s-OFDM 256 QAM	135@ 67	18.19	14.48	0.0281
78	15	50	631667	3475.005	DFT-s-OFDM 256 QAM	1@1	18.27	14.56	0.0286
78	15	50	631667	3475.005	DFT-s-OFDM 256 QAM	1@26 8	18.12	14.41	0.0276
78	15	50	631667	3475.005	CP-OFDM QPSK	135@ 67	21.11	17.4	0.0550
78	15	50	631667	3475.005	CP-OFDM QPSK	1@1	21.13	17.42	0.0552

78	15	50	631667	3475.005	CP-OFDM QPSK	1@26 8	21.01	17.3	0.0537
78	15	50	633334	3500.01	DFT-s-OFDM PI/2 BPSK	135@ 67	22.75	19.04	0.0802
78	15	50	633334	3500.01	DFT-s-OFDM PI/2 BPSK	1@1	22.47	18.76	0.0752
78	15	50	633334	3500.01	DFT-s-OFDM PI/2 BPSK	1@26 8	22.44	18.73	0.0746
78	15	50	633334	3500.01	DFT-s-OFDM QPSK	135@ 67	22.75	19.04	0.0802
78	15	50	633334	3500.01	DFT-s-OFDM QPSK	1@1	22.49	18.78	0.0755
78	15	50	633334	3500.01	DFT-s-OFDM QPSK	1@26 8	22.39	18.68	0.0738
78	15	50	633334	3500.01	DFT-s-OFDM 16 QAM	135@ 67	21.75	18.04	0.0637
78	15	50	633334	3500.01	DFT-s-OFDM 16 QAM	1@1	21.52	17.81	0.0604
78	15	50	633334	3500.01	DFT-s-OFDM 16 QAM	1@26 8	21.2	17.49	0.0561
78	15	50	633334	3500.01	DFT-s-OFDM 64 QAM	135@ 67	20.23	16.52	0.0449
78	15	50	633334	3500.01	DFT-s-OFDM 64 QAM	1@1	20.13	16.42	0.0439
78	15	50	633334	3500.01	DFT-s-OFDM 64 QAM	1@26 8	20.03	16.32	0.0429
78	15	50	633334	3500.01	DFT-s-OFDM 256 QAM	135@ 67	18.26	14.55	0.0285
78	15	50	633334	3500.01	DFT-s-OFDM 256 QAM	1@1	18.19	14.48	0.0281
78	15	50	633334	3500.01	DFT-s-OFDM 256 QAM	1@26 8	18.12	14.41	0.0276
78	15	50	633334	3500.01	CP-OFDM QPSK	135@ 67	21.22	17.51	0.0564
78	15	50	633334	3500.01	CP-OFDM QPSK	1@1	21.09	17.38	0.0547
78	15	50	633334	3500.01	CP-OFDM QPSK	1@26 8	21.03	17.32	0.0540
78	15	50	635000	3525	DFT-s-OFDM PI/2 BPSK	135@ 67	22.82	19.11	0.0815
78	15	50	635000	3525	DFT-s-OFDM PI/2 BPSK	1@1	22.61	18.9	0.0776
78	15	50	635000	3525	DFT-s-OFDM PI/2 BPSK	1@26 8	22.43	18.72	0.0745
78	15	50	635000	3525	DFT-s-OFDM QPSK	135@ 67	22.79	19.08	0.0809
78	15	50	635000	3525	DFT-s-OFDM QPSK	1@1	22.69	18.98	0.0791
78	15	50	635000	3525	DFT-s-OFDM QPSK	1@26 8	22.4	18.69	0.0740
78	15	50	635000	3525	DFT-s-OFDM 16 QAM	135@ 67	21.79	18.08	0.0643
78	15	50	635000	3525	DFT-s-OFDM 16 QAM	1@1	21.65	17.94	0.0622
78	15	50	635000	3525	DFT-s-OFDM 16 QAM	1@26 8	21.23	17.52	0.0565
78	15	50	635000	3525	DFT-s-OFDM 64 QAM	135@ 67	20.33	16.62	0.0459
78	15	50	635000	3525	DFT-s-OFDM 64 QAM	1@1	20.21	16.5	0.0447
78	15	50	635000	3525	DFT-s-OFDM 64 QAM	1@26 8	19.97	16.26	0.0423
78	15	50	635000	3525	DFT-s-OFDM 256 QAM	135@ 67	18.31	14.6	0.0288
78	15	50	635000	3525	DFT-s-OFDM 256 QAM	1@1	18.36	14.65	0.0292
78	15	50	635000	3525	DFT-s-OFDM 256 QAM	1@26 8	18.15	14.44	0.0278

78	15	50	635000	3525	CP-OFDM QPSK	135@ 67	21.27	17.56	0.0570
78	15	50	635000	3525	CP-OFDM QPSK	1@1	21.27	17.56	0.0570
78	15	50	635000	3525	CP-OFDM QPSK	1@26 8	21.04	17.33	0.0541

Frequency Stability

NR Band	SCS (kHz)	Bandwidth (MHz)	Arfcn	Freq (MHz)	Modulation	RB	Deviation (ppm)	Verdict	Environment
78	15	10	633334	3500.01	DFT-s-OFDM QPSK	50@0	0.0012	PASS	NV
78	15	10	633334	3500.01	DFT-s-OFDM QPSK	50@0	0.0014	PASS	LV
78	15	10	633334	3500.01	DFT-s-OFDM QPSK	50@0	-0.0026	PASS	HV
78	15	10	633334	3500.01	DFT-s-OFDM QPSK	50@0	0.0014	PASS	-30°C
78	15	10	633334	3500.01	DFT-s-OFDM QPSK	50@0	0.0021	PASS	-20°C
78	15	10	633334	3500.01	DFT-s-OFDM QPSK	50@0	0.0029	PASS	-10°C
78	15	10	633334	3500.01	DFT-s-OFDM QPSK	50@0	0.0016	PASS	0°C
78	15	10	633334	3500.01	DFT-s-OFDM QPSK	50@0	0.0031	PASS	10°C
78	15	10	633334	3500.01	DFT-s-OFDM QPSK	50@0	0.0014	PASS	20°C
78	15	10	633334	3500.01	DFT-s-OFDM QPSK	50@0	-0.0041	PASS	30°C
78	15	10	633334	3500.01	DFT-s-OFDM QPSK	50@0	0.0035	PASS	40°C
78	15	10	633334	3500.01	DFT-s-OFDM QPSK	50@0	0.0026	PASS	50°C

Peak to Average Ratio

NR Band	SCS (kHz)	Bandwidth (MHz)	Arfcn	Freq (MHz)	Modulation	RB	Result (dB)	Limit (dB)	Verdict
78	30	50	633334	3500.01	DFT-s-OFDM PI/2 BPSK	128@0	9.42	13	PASS
78	15	50	633334	3500.01	DFT-s-OFDM PI/2 BPSK	1@0	6.72	13	PASS
78	15	50	633334	3500.01	DFT-s-OFDM QPSK	270@0	10.1	13	PASS
78	15	50	633334	3500.01	DFT-s-OFDM QPSK	1@0	7.75	13	PASS

N78(50M)_DFT-s-OFDM_PI_2-BPSK_Outer_Full_Mid_CH



N78(50M)_DFT-s-OFDM_PI_2-BPSK_Edge_1RB_Left_Mid_CH

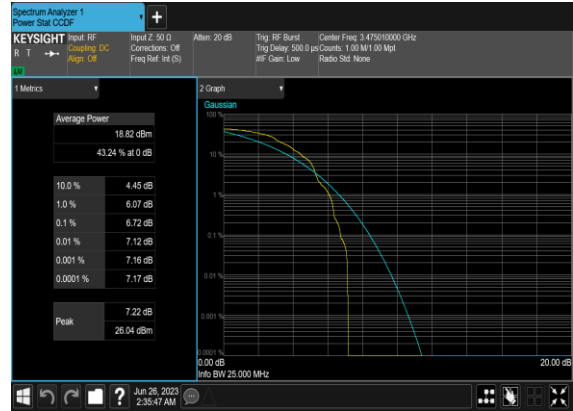

N78(50M)_DFT-s-OFDM_QPSK_Outer_Full_Mid_CH



N78(50M)_DFT-s-OFDM_QPSK_Edge_1RB_Left_Mid_CH

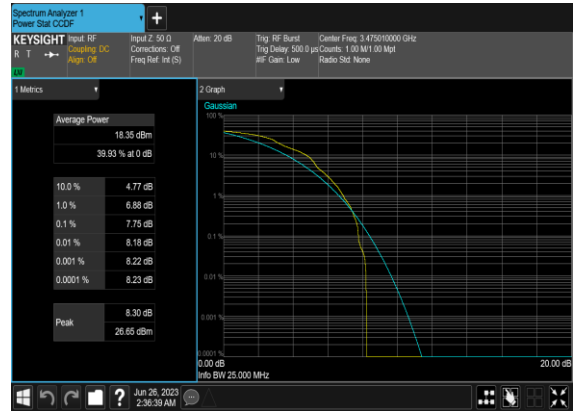

Occupied Bandwidth

NR Band	SCS (kHz)	Bandwidth (MHz)	Arfcn	Freq (MHz)	Modulation	RB	OBW (MHz)	26dB BW (MHz)
78	15	10	633334	3500.01	CP-OFDM QPSK	52@0	9.262	9.787
78	15	10	633334	3500.01	CP-OFDM 16 QAM	52@0	9.2541	9.759
78	15	10	633334	3500.01	CP-OFDM 64 QAM	52@0	9.2383	9.808
78	15	10	633334	3500.01	CP-OFDM 256 QAM	52@0	9.2684	9.745
78	15	15	633334	3500.01	CP-OFDM QPSK	79@0	14.1	14.88
78	15	15	633334	3500.01	CP-OFDM 16 QAM	79@0	14.07	14.6
78	15	15	633334	3500.01	CP-OFDM 64 QAM	79@0	14.121	14.65
78	15	15	633334	3500.01	CP-OFDM 256 QAM	79@0	14.073	14.54
78	15	20	633334	3500.01	CP-OFDM QPSK	106@0	18.904	19.67
78	15	20	633334	3500.01	CP-OFDM 16 QAM	106@0	18.872	19.6
78	15	20	633334	3500.01	CP-OFDM 64 QAM	106@0	18.878	19.52
78	15	20	633334	3500.01	CP-OFDM 256 QAM	106@0	18.827	19.63
78	15	30	633334	3500.01	CP-OFDM QPSK	160@0	28.56	29.44
78	15	30	633334	3500.01	CP-OFDM 16 QAM	160@0	28.609	29.47
78	15	30	633334	3500.01	CP-OFDM 64 QAM	160@0	28.549	29.51
78	15	30	633334	3500.01	CP-OFDM 256 QAM	160@0	28.568	29.47
78	15	40	633334	3500.01	CP-OFDM QPSK	216@0	38.452	40.21
78	15	40	633334	3500.01	CP-OFDM 16 QAM	216@0	38.457	39.74
78	15	40	633334	3500.01	CP-OFDM 64 QAM	216@0	38.533	39.78
78	15	40	633334	3500.01	CP-OFDM 256 QAM	216@0	38.515	39.75
78	15	50	633334	3500.01	CP-OFDM QPSK	270@0	48.124	49.72
78	15	50	633334	3500.01	CP-OFDM 16 QAM	270@0	48.004	49.68
78	15	50	633334	3500.01	CP-OFDM 64 QAM	270@0	48.097	49.7
78	15	50	633334	3500.01	CP-OFDM 256 QAM	270@0	48.187	49.71

N78(10M)_CP-OFDM_QPSK_Outer_Full_Mid_CH

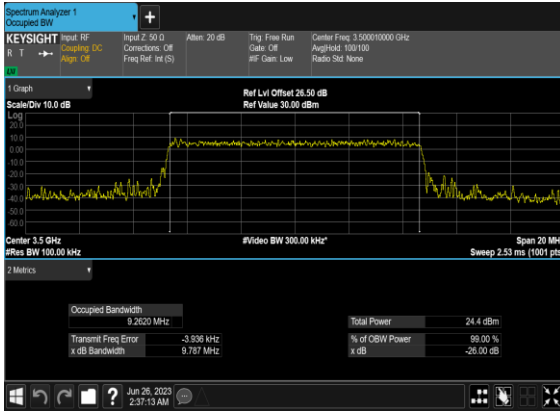

N78(10M)_CP-OFDM_16QAM_Outer_Full_Mid_CH

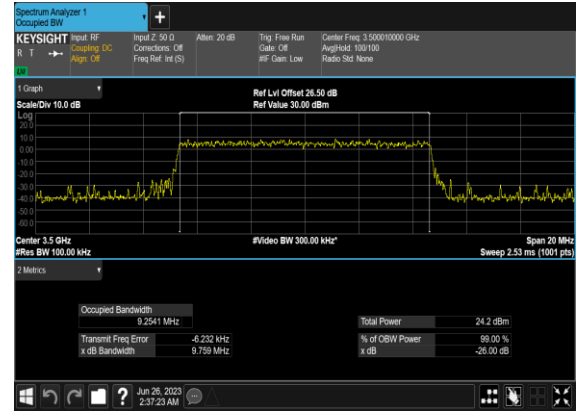

N78(10M)_CP-OFDM_64QAM_Outer_Full_Mid_CH

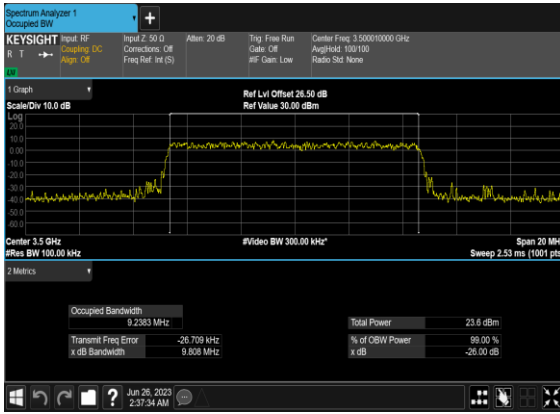

N78(10M)_CP-OFDM_256QAM_Outer_Full_Mid_CH

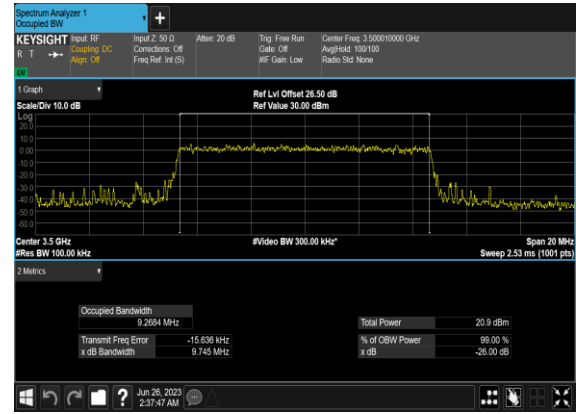

N78(15M)_CP-OFDM_QPSK_Outer_Full_Mid_CH

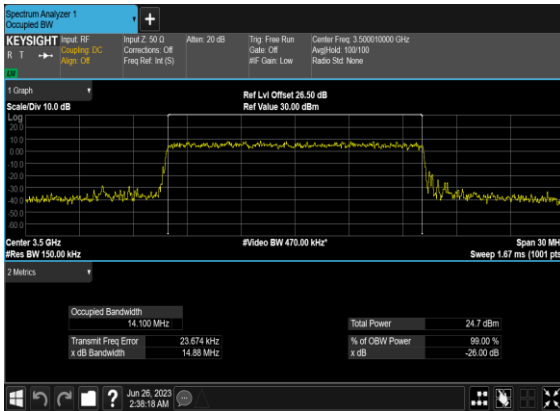

N78(15M)_CP-OFDM_16QAM_Outer_Full_Mid_CH

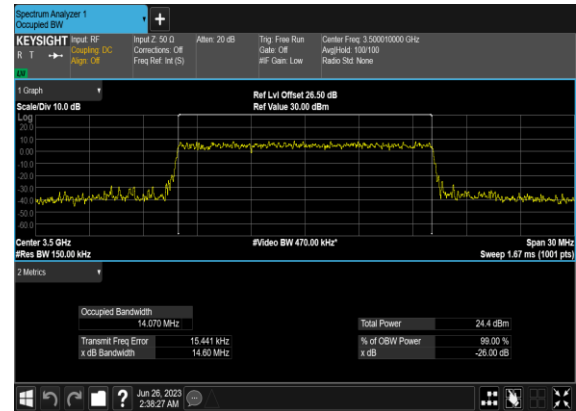

N78(15M)_CP-OFDM_64 QAM_Outer_Full_Mid_CH

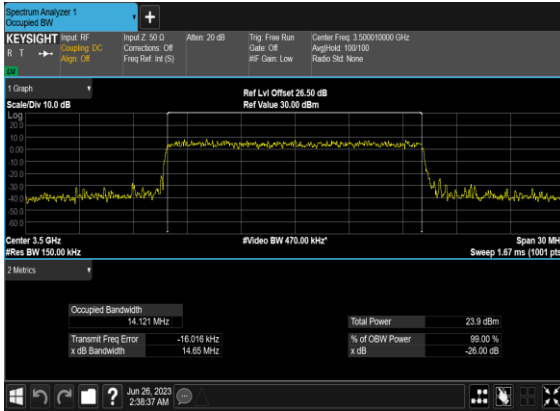

N78(15M)_CP-OFDM_256 QAM_Outer_Full_Mid_CH

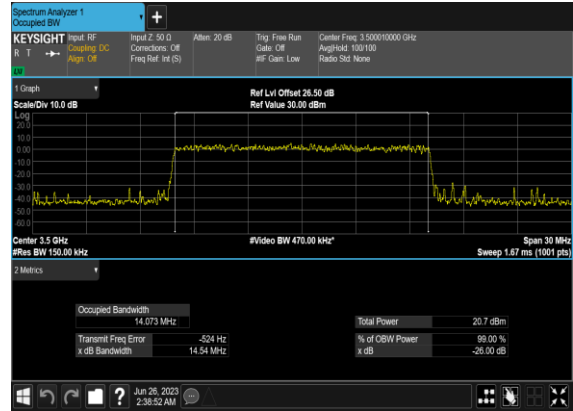

N78(20M)_CP- OFDM_QPSK_Outer_Full_Mid_CH

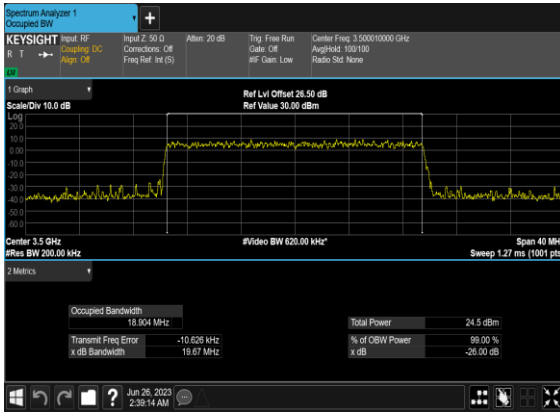

N78(20M)_CP-OFDM_16 QAM_Outer_Full_Mid_CH

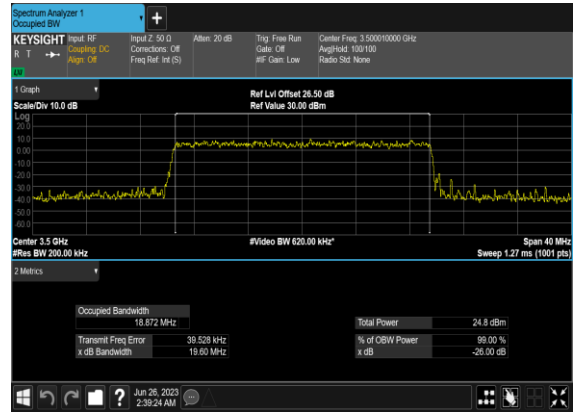

N78(20M)_CP-OFDM_64 QAM_Outer_Full_Mid_CH

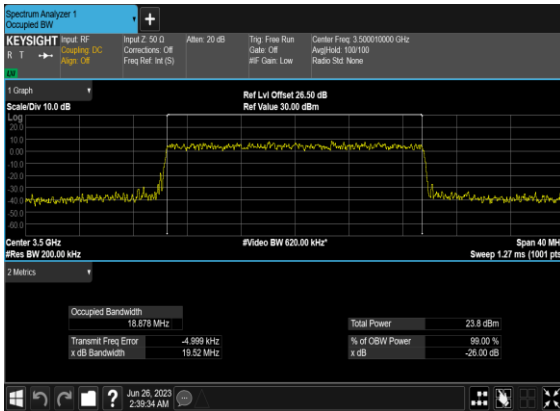

N78(20M)_CP-OFDM_256 QAM_Outer_Full_Mid_CH

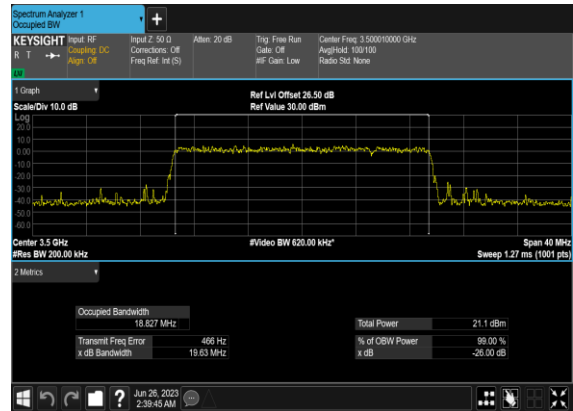

N78(30M)_CP-OFDM_QPSK_Outer_Full_Mid_CH

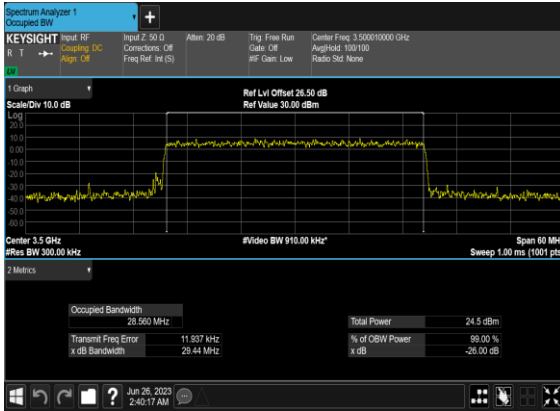

N78(30M)_CP-OFDM_16QAM_Outer_Full_Mid_CH

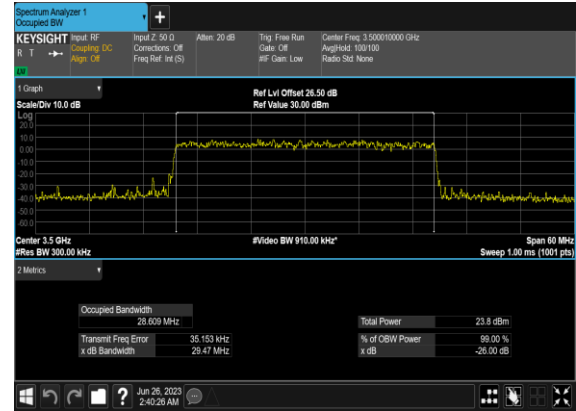

N78(30M)_CP-OFDM_64QAM_Outer_Full_Mid_CH

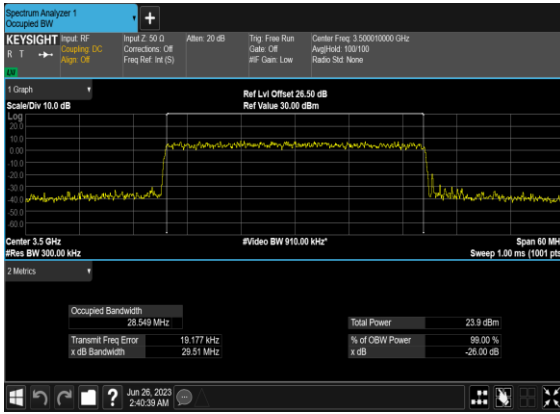

N78(30M)_CP-OFDM_256QAM_Outer_Full_Mid_CH

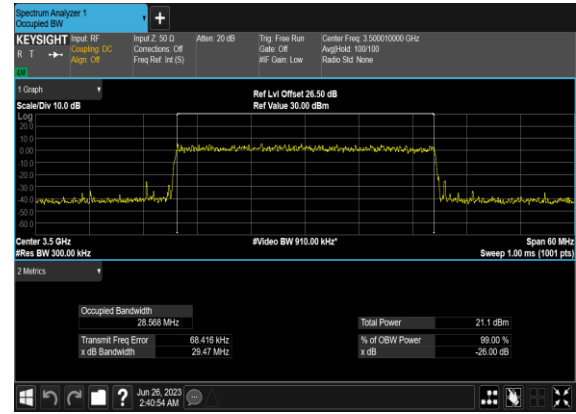

N78(40M)_CP-OFDM_QPSK_Outer_Full_Mid_CH

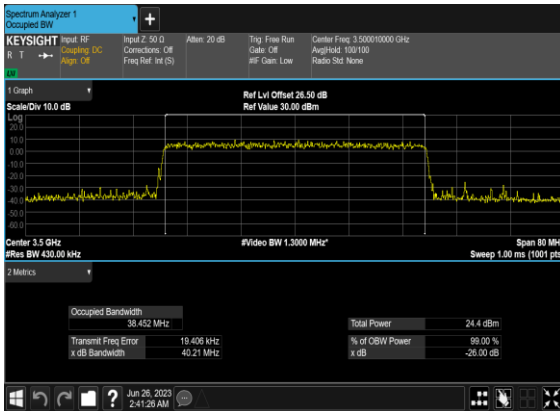

N78(40M)_CP-OFDM_16QAM_Outer_Full_Mid_CH

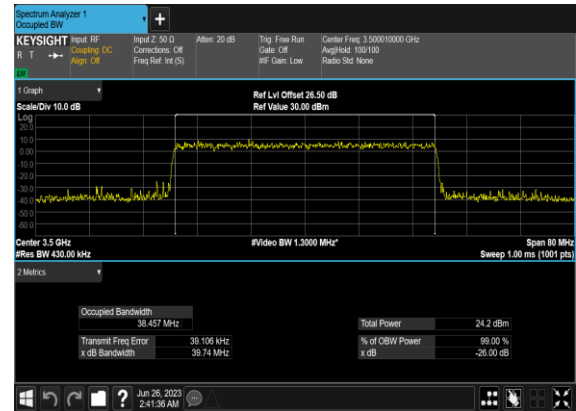

N78(40M)_CP-OFDM_64 QAM_Outer_Full_Mid_CH

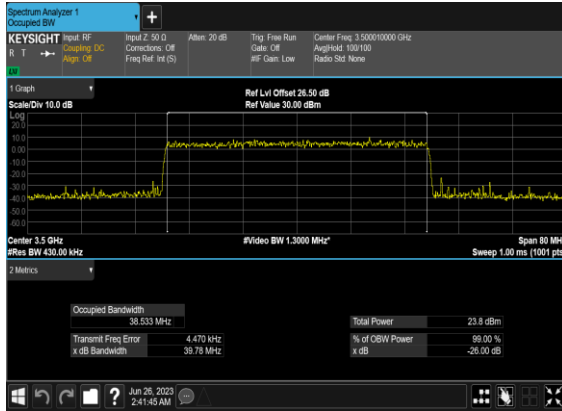

N78(40M)_CP-OFDM_256 QAM_Outer_Full_Mid_CH

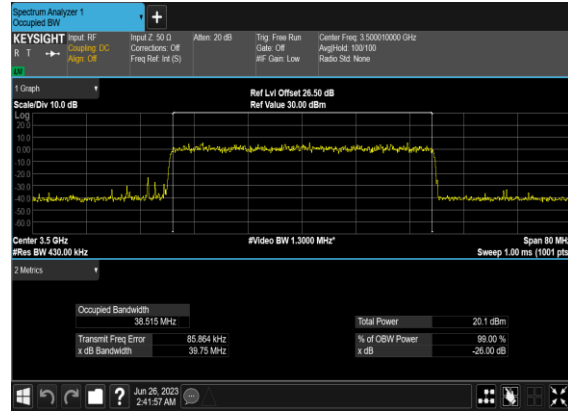

N78(50M)_CP- OFDM_QPSK_Outer_Full_Mid_CH

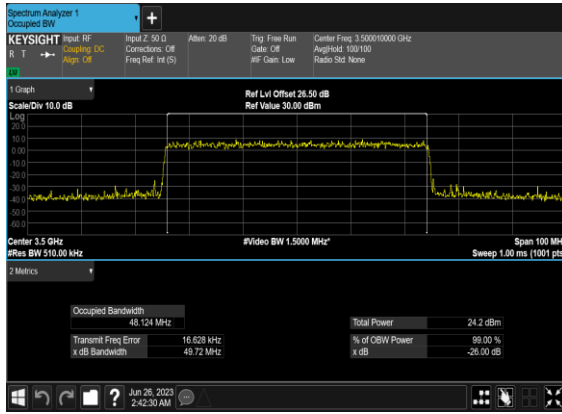

N78(50M)_CP-OFDM_16 QAM_Outer_Full_Mid_CH

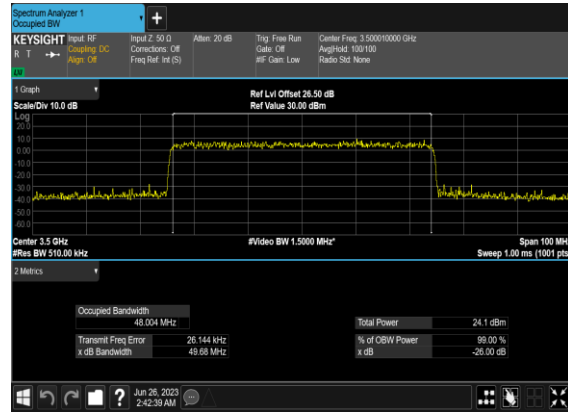

N78(50M)_CP-OFDM_64 QAM_Outer_Full_Mid_CH

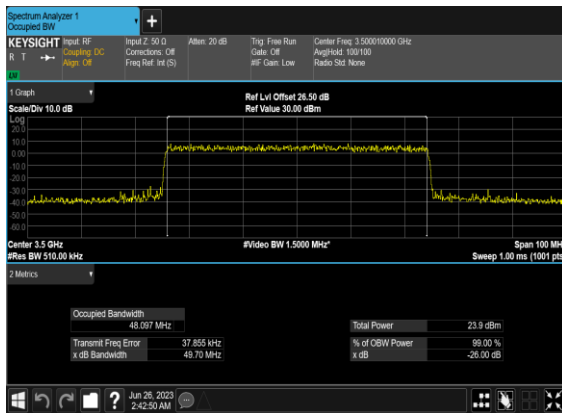

N78(50M)_CP-OFDM_256 QAM_Outer_Full_Mid_CH

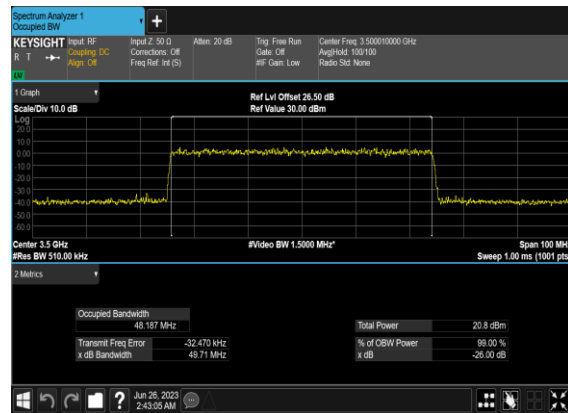

Conducted Spurious Emissions

NR Band	SCS (kHz)	Bandwidth (MHz)	Arfcn	Freq (MHz)	Modulation	RB	Result	Verdict
78	15	10	630334	3455.01	DFT-s-OFDM BPSK	1@0	see graph	---
78	15	10	630334	3455.01	DFT-s-OFDM BPSK	1@0	see graph	PASS
78	15	10	630334	3455.01	DFT-s-OFDM BPSK	1@0	see graph	PASS
78	15	10	630334	3455.01	DFT-s-OFDM QPSK	1@0	see graph	---
78	15	10	630334	3455.01	DFT-s-OFDM QPSK	1@0	see graph	PASS
78	15	10	630334	3455.01	DFT-s-OFDM QPSK	1@0	see graph	PASS
78	15	10	633334	3500.01	DFT-s-OFDM BPSK	1@0	see graph	---
78	15	10	633334	3500.01	DFT-s-OFDM BPSK	1@0	see graph	PASS
78	15	10	633334	3500.01	DFT-s-OFDM BPSK	1@0	see graph	PASS
78	15	10	633334	3500.01	DFT-s-OFDM QPSK	1@0	see graph	---
78	15	10	633334	3500.01	DFT-s-OFDM QPSK	1@0	see graph	PASS
78	15	10	633334	3500.01	DFT-s-OFDM QPSK	1@0	see graph	PASS
78	15	10	636333	3544.995	DFT-s-OFDM BPSK	1@0	see graph	---
78	15	10	636333	3544.995	DFT-s-OFDM BPSK	1@0	see graph	PASS
78	15	10	636333	3544.995	DFT-s-OFDM BPSK	1@0	see graph	PASS
78	15	10	636333	3544.995	DFT-s-OFDM QPSK	1@0	see graph	---
78	15	10	636333	3544.995	DFT-s-OFDM QPSK	1@0	see graph	PASS
78	15	10	636333	3544.995	DFT-s-OFDM QPSK	1@0	see graph	PASS
78	15	30	631000	3465.0	DFT-s-OFDM BPSK	1@0	see graph	---
78	15	30	631000	3465.0	DFT-s-OFDM BPSK	1@0	see graph	PASS
78	15	30	631000	3465.0	DFT-s-OFDM BPSK	1@0	see graph	PASS

78	15	30	631000	3465.0	DFT-s-OFDM QPSK	1@0	see graph	---
78	15	30	631000	3465.0	DFT-s-OFDM QPSK	1@0	see graph	PASS
78	15	30	631000	3465.0	DFT-s-OFDM QPSK	1@0	see graph	PASS
78	15	30	633334	3500.01	DFT-s-OFDM BPSK	1@0	see graph	---
78	15	30	633334	3500.01	DFT-s-OFDM BPSK	1@0	see graph	PASS
78	15	30	633334	3500.01	DFT-s-OFDM BPSK	1@0	see graph	PASS
78	15	30	633334	3500.01	DFT-s-OFDM QPSK	1@0	see graph	---
78	15	30	633334	3500.01	DFT-s-OFDM QPSK	1@0	see graph	PASS
78	15	30	633334	3500.01	DFT-s-OFDM QPSK	1@0	see graph	PASS
78	15	30	635666	3534.99	DFT-s-OFDM BPSK	1@0	see graph	---
78	15	30	635666	3534.99	DFT-s-OFDM BPSK	1@0	see graph	PASS
78	15	30	635666	3534.99	DFT-s-OFDM BPSK	1@0	see graph	PASS
78	15	30	635666	3534.99	DFT-s-OFDM QPSK	1@0	see graph	---
78	15	30	635666	3534.99	DFT-s-OFDM QPSK	1@0	see graph	PASS
78	15	30	635666	3534.99	DFT-s-OFDM QPSK	1@0	see graph	PASS
78	15	50	631667	3475.005	DFT-s-OFDM BPSK	1@0	see graph	---
78	15	50	631667	3475.005	DFT-s-OFDM BPSK	1@0	see graph	PASS
78	15	50	631667	3475.005	DFT-s-OFDM BPSK	1@0	see graph	PASS
78	15	50	631667	3475.005	DFT-s-OFDM QPSK	1@0	see graph	---
78	15	50	631667	3475.005	DFT-s-OFDM QPSK	1@0	see graph	PASS
78	15	50	631667	3475.005	DFT-s-OFDM QPSK	1@0	see graph	PASS
78	15	50	633334	3500.01	DFT-s-OFDM BPSK	1@0	see graph	---
78	15	50	633334	3500.01	DFT-s-OFDM BPSK	1@0	see graph	PASS
78	15	50	633334	3500.01	DFT-s-OFDM BPSK	1@0	see graph	PASS

78	15	50	633334	3500.01	DFT-s-OFDM QPSK	1@0	see graph	---
78	15	50	633334	3500.01	DFT-s-OFDM QPSK	1@0	see graph	PASS
78	15	50	633334	3500.01	DFT-s-OFDM QPSK	1@0	see graph	PASS
78	15	50	635000	3525.0	DFT-s-OFDM BPSK	1@0	see graph	---
78	15	50	635000	3525.0	DFT-s-OFDM BPSK	1@0	see graph	PASS
78	15	50	635000	3525.0	DFT-s-OFDM BPSK	1@0	see graph	PASS
78	15	50	635000	3525.0	DFT-s-OFDM QPSK	1@0	see graph	---
78	15	50	635000	3525.0	DFT-s-OFDM QPSK	1@0	see graph	PASS
78	15	50	635000	3525.0	DFT-s-OFDM QPSK	1@0	see graph	PASS

N78(10M)_DFT-s-OFDM_BPSK_Edge_1RB_Left_Low_CH

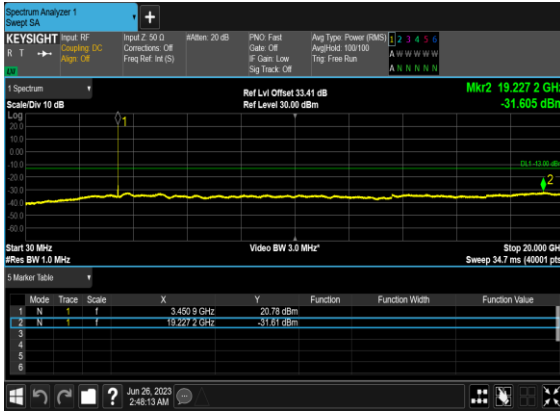

N78(10M)_DFT-s-OFDM_BPSK_Edge_1RB_Left_Low_CH

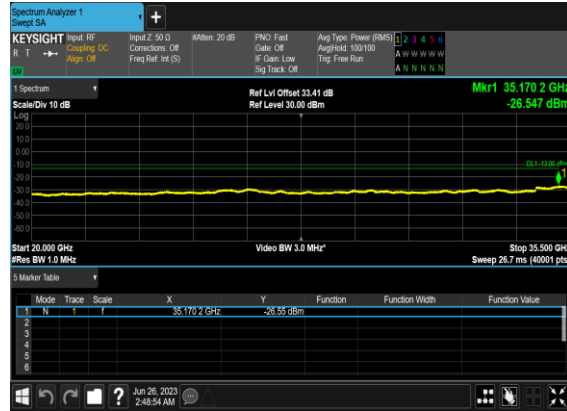

N78(10M)_DFT-s-OFDM_QPSK_Edge_1RB_Left_Low_CH

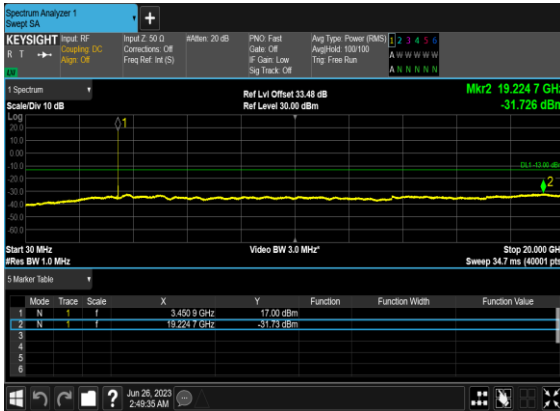

N78(10M)_DFT-s-OFDM_QPSK_Edge_1RB_Left_Low_CH

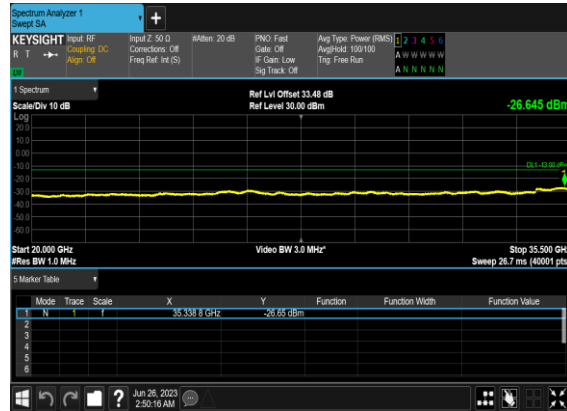

N78(10M)_DFT-s-OFDM_BPSK_Edge_1RB_Left_Mid_CH

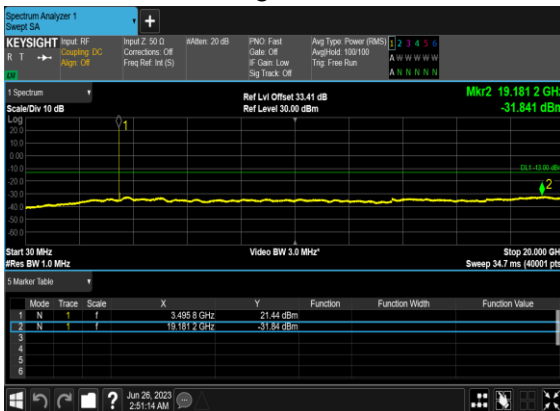

N78(10M)_DFT-s-OFDM_BPSK_Edge_1RB_Left_Mid_CH

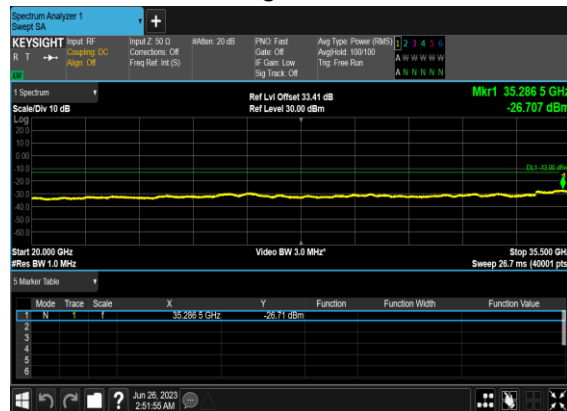

N78(10M)_DFT-s-OFDM_QPSK_Edge_1RB_Left_Mid_CH

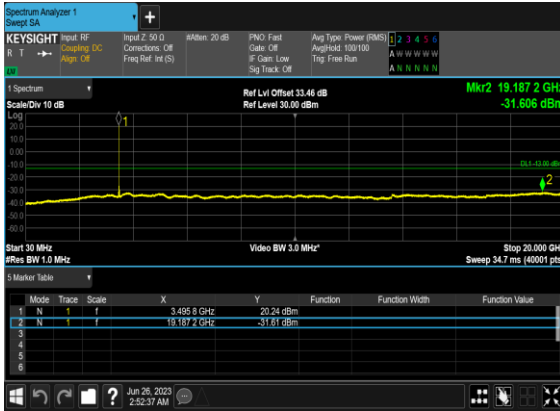

N78(10M)_DFT-s-OFDM_QPSK_Edge_1RB_Left_Mid_CH

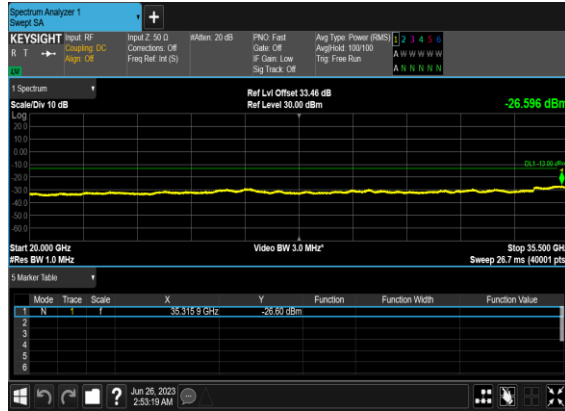

N78(10M)_DFT-s-OFDM_BPSK_Edge_1RB_Left_High_CH

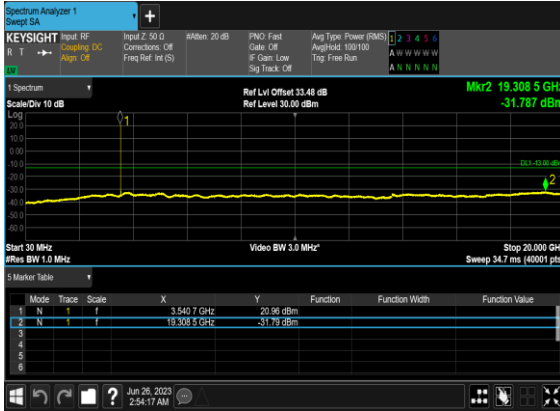

N78(10M)_DFT-s-OFDM_BPSK_Edge_1RB_Left_High_CH

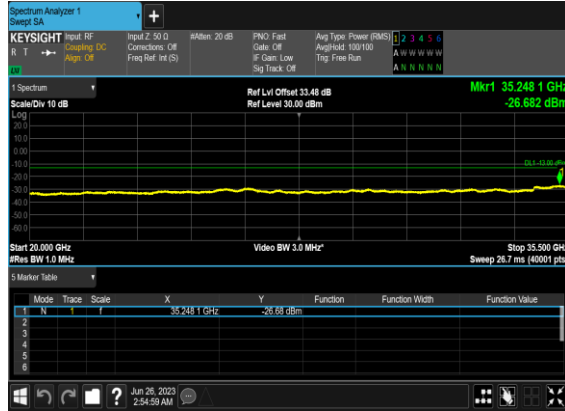

N78(10M)_DFT-s-OFDM_QPSK_Edge_1RB_Left_High_CH

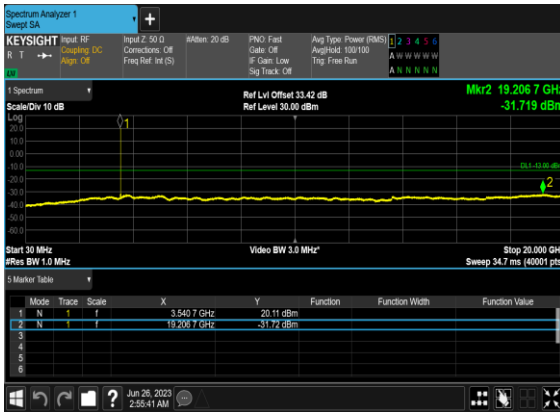

N78(10M)_DFT-s-OFDM_QPSK_Edge_1RB_Left_High_CH

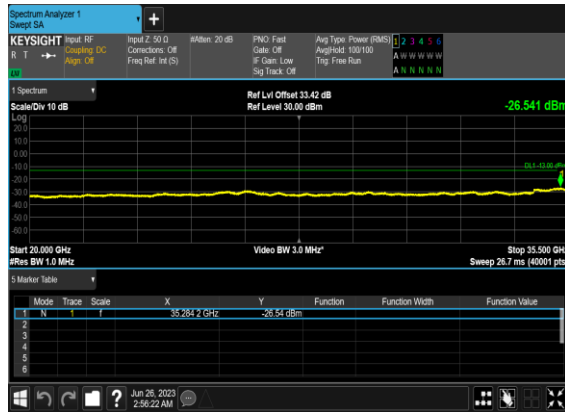

N78(30M)_DFT-s-OFDM_BPSK_Edge_1RB_Left_Low_CH

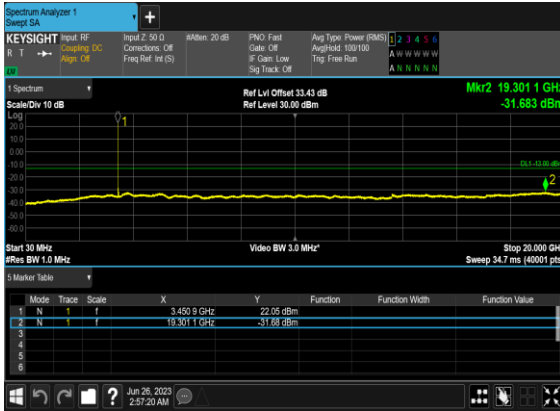

N78(30M)_DFT-s-OFDM_BPSK_Edge_1RB_Left_Low_CH

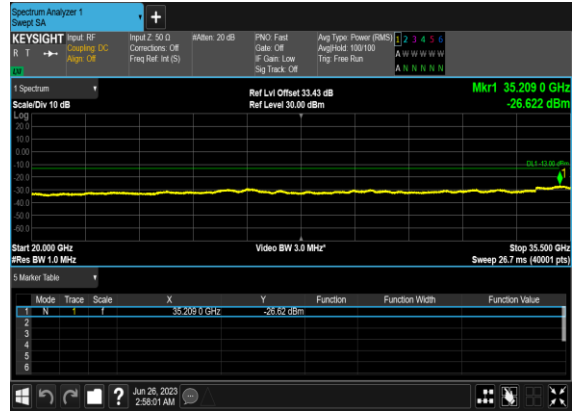

N78(30M)_DFT-s-OFDM_QPSK_Edge_1RB_Left_Low_CH

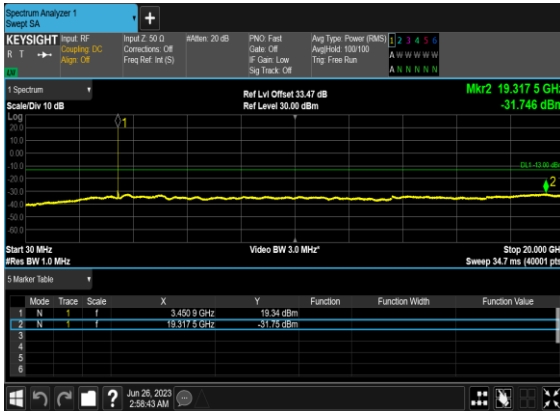

N78(30M)_DFT-s-OFDM_QPSK_Edge_1RB_Left_Low_CH

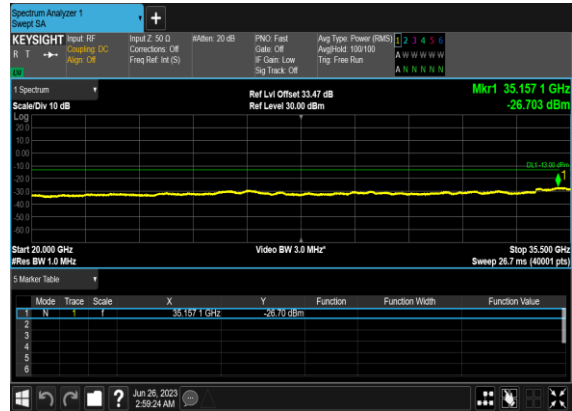

N78(30M)_DFT-s-OFDM_BPSK_Edge_1RB_Left_Mid_CH

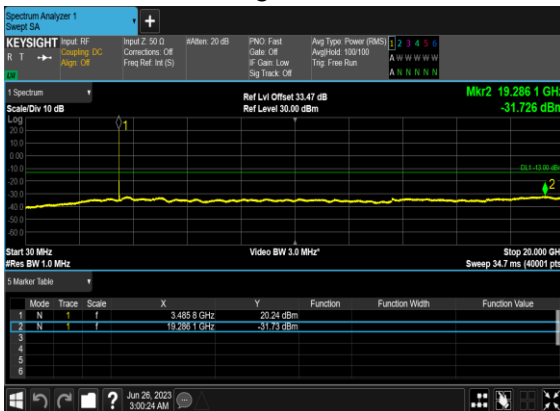

N78(30M)_DFT-s-OFDM_BPSK_Edge_1RB_Left_Mid_CH

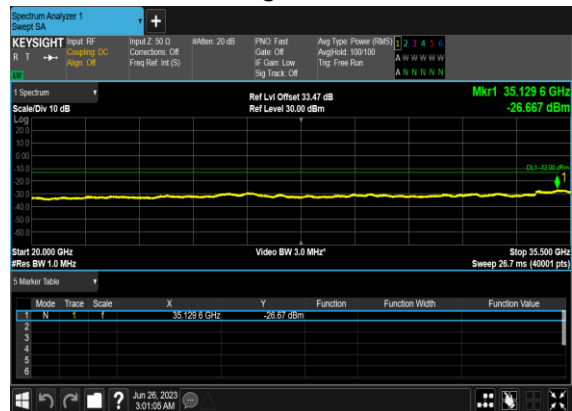

N78(30M)_DFT-s-OFDM_QPSK_Edge_1RB_Left_Mid_CH

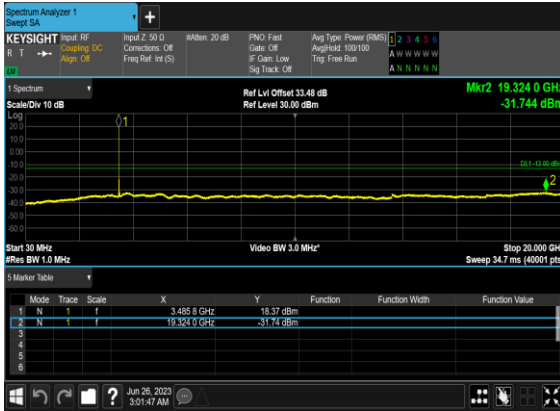

N78(30M)_DFT-s-OFDM_QPSK_Edge_1RB_Left_Mid_CH

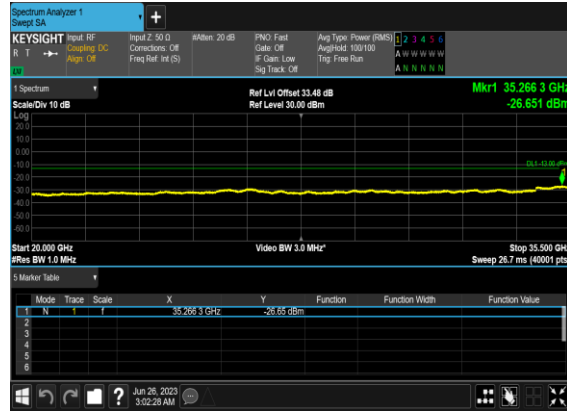

N78(30M)_DFT-s-OFDM_BPSK_Edge_1RB_Left_High_CH

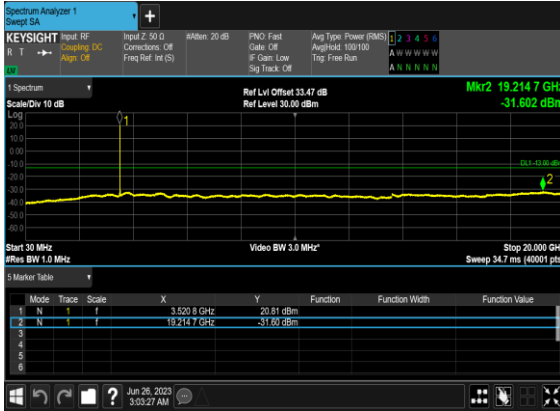

N78(30M)_DFT-s-OFDM_BPSK_Edge_1RB_Left_High_CH

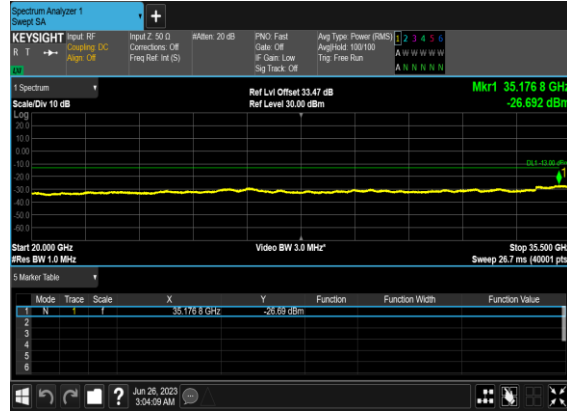

N78(30M)_DFT-s-OFDM_QPSK_Edge_1RB_Left_High_CH

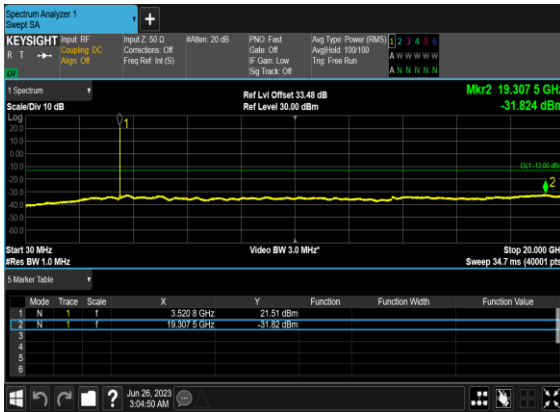

N78(30M)_DFT-s-OFDM_QPSK_Edge_1RB_Left_High_CH

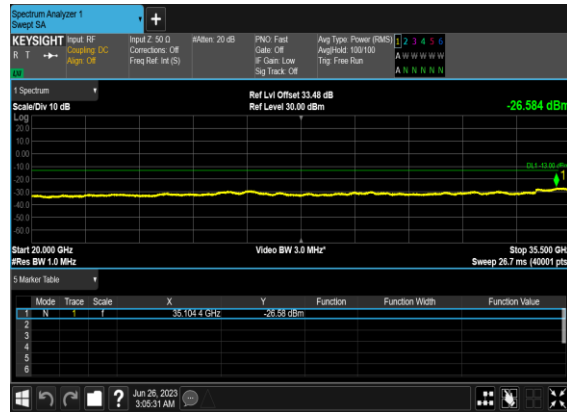

N78(50M)_DFT-s-OFDM_BPSK_Edge_1RB_Left_Low_CH

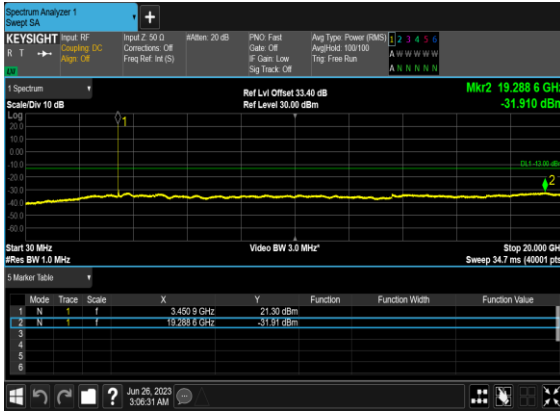

N78(50M)_DFT-s-OFDM_BPSK_Edge_1RB_Left_Low_CH

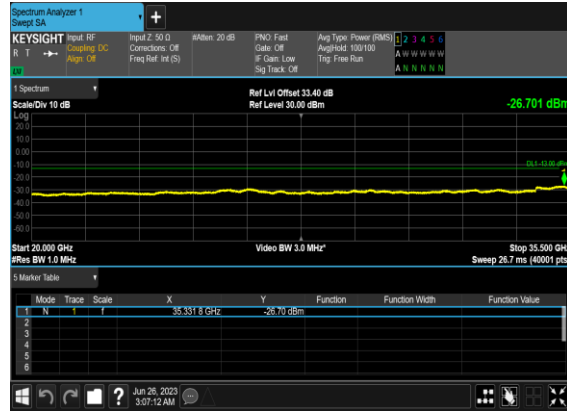

N78(50M)_DFT-s-OFDM_QPSK_Edge_1RB_Left_Low_CH

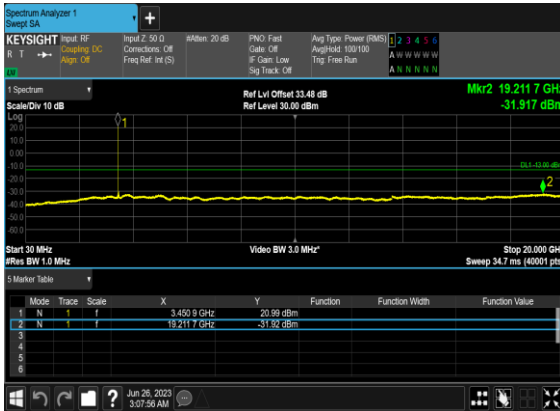

N78(50M)_DFT-s-OFDM_QPSK_Edge_1RB_Left_Low_CH

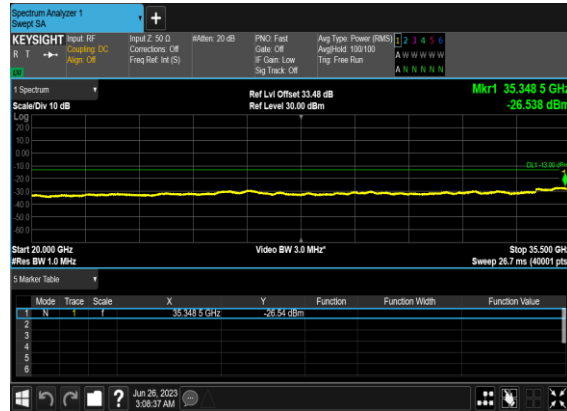

N78(50M)_DFT-s-OFDM_BPSK_Edge_1RB_Left_Mid_CH

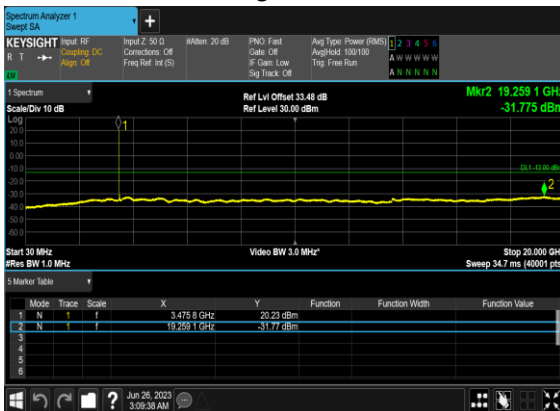

N78(50M)_DFT-s-OFDM_BPSK_Edge_1RB_Left_Mid_CH

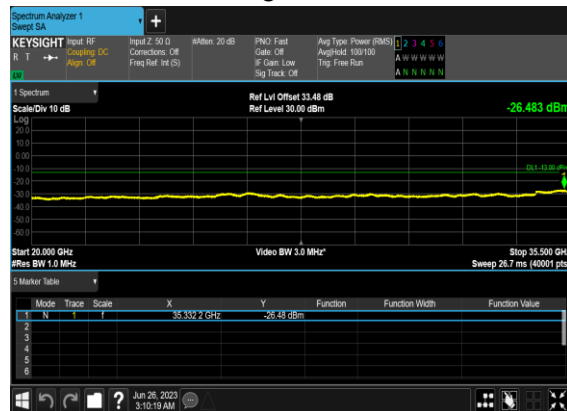

N78(50M)_DFT-s-OFDM_QPSK_Edge_1RB_Left_Mid_CH

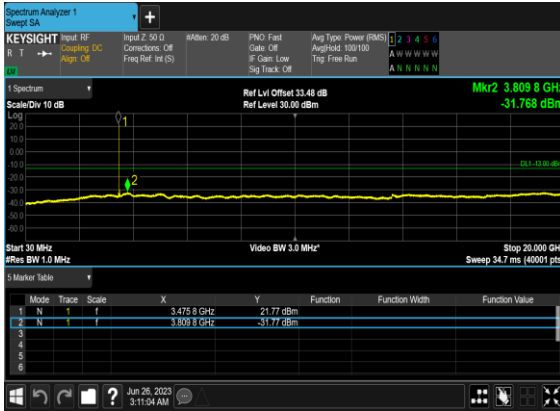

N78(50M)_DFT-s-OFDM_QPSK_Edge_1RB_Left_Mid_CH

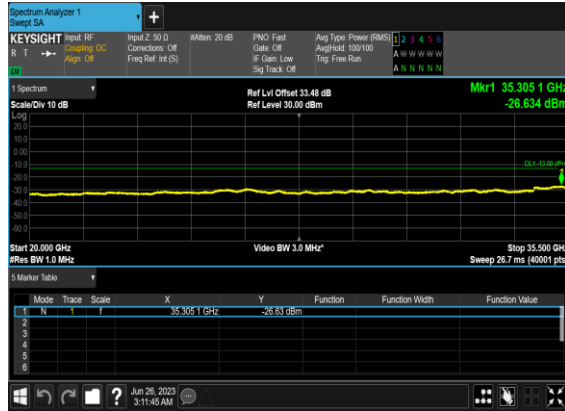

N78(50M)_DFT-s-OFDM_BPSK_Edge_1RB_Left_High_CH

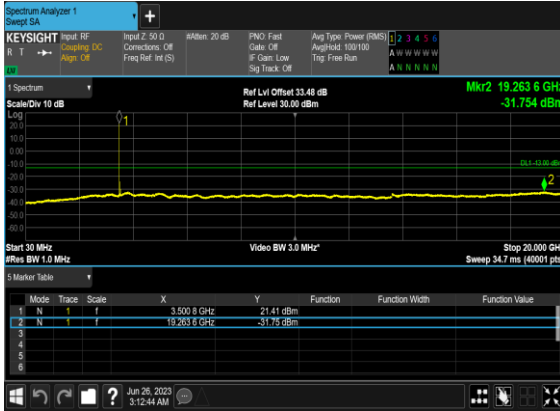

N78(50M)_DFT-s-OFDM_BPSK_Edge_1RB_Left_High_CH

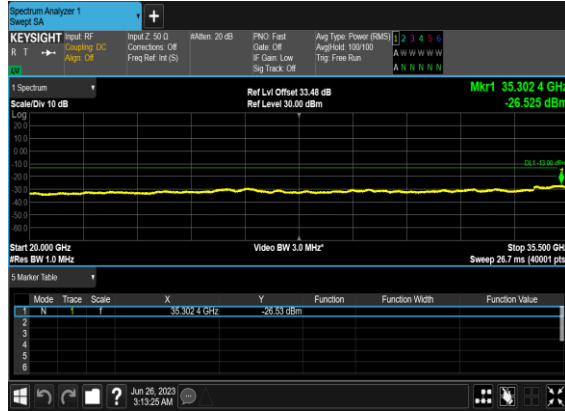

N78(50M)_DFT-s-OFDM_QPSK_Edge_1RB_Left_High_CH

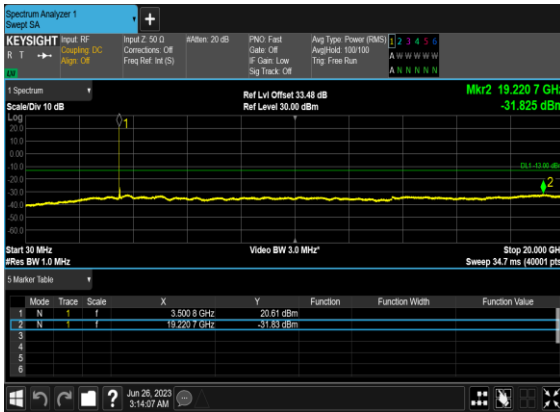

N78(50M)_DFT-s-OFDM_QPSK_Edge_1RB_Left_High_CH

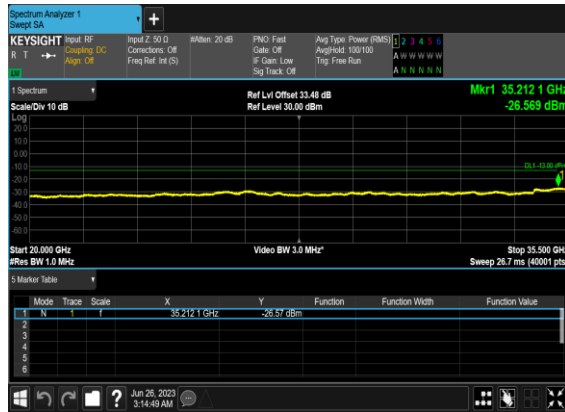

Conducted Band Edge

NR Band	SCS (kHz)	Bandwidth (MHz)	Arfcn	Freq (MHz)	Modulation	RB	Result	Verdict
78	15	10	630334	3455.01	DFT-s-OFDM BPSK	1@0	see graph	PASS
78	15	10	630334	3455.01	DFT-s-OFDM QPSK	1@0	see graph	PASS
78	15	10	630334	3455.01	DFT-s-OFDM BPSK	50@0	see graph	PASS
78	15	10	630334	3455.01	DFT-s-OFDM QPSK	50@0	see graph	PASS
78	15	10	636333	3544.995	DFT-s-OFDM BPSK	1@51	see graph	PASS
78	15	10	636333	3544.995	DFT-s-OFDM QPSK	1@51	see graph	PASS
78	15	10	636333	3544.995	DFT-s-OFDM BPSK	50@0	see graph	PASS
78	15	10	636333	3544.995	DFT-s-OFDM QPSK	50@0	see graph	PASS
78	15	30	631000	3465.0	DFT-s-OFDM BPSK	1@0	see graph	PASS
78	15	30	631000	3465.0	DFT-s-OFDM QPSK	1@0	see graph	PASS
78	15	30	631000	3465.0	DFT-s-OFDM BPSK	160@0	see graph	PASS
78	15	30	631000	3465.0	DFT-s-OFDM QPSK	160@0	see graph	PASS
78	15	30	635666	3534.99	DFT-s-OFDM BPSK	1@159	see graph	PASS
78	15	30	635666	3534.99	DFT-s-OFDM QPSK	1@159	see graph	PASS
78	15	30	635666	3534.99	DFT-s-OFDM BPSK	160@0	see graph	PASS
78	15	30	635666	3534.99	DFT-s-OFDM QPSK	160@0	see graph	PASS
78	15	50	631667	3475.005	DFT-s-OFDM BPSK	1@0	see graph	PASS
78	15	50	631667	3475.005	DFT-s-OFDM QPSK	1@0	see graph	PASS
78	15	50	631667	3475.005	DFT-s-OFDM BPSK	270@0	see graph	PASS
78	15	50	631667	3475.005	DFT-s-OFDM QPSK	270@0	see graph	PASS
78	15	50	635000	3475.005	DFT-s-OFDM BPSK	1@0	see graph	PASS
78	15	50	635000	3525.0	DFT-s-OFDM BPSK	1@269	see graph	PASS
78	15	50	635000	3525.0	DFT-s-OFDM QPSK	1@269	see graph	PASS
78	15	50	635000	3525.0	DFT-s-OFDM BPSK	270@0	see graph	PASS
78	15	50	635000	3525.0	DFT-s-OFDM QPSK	270@0	see graph	PASS

N78(10M)_DFT-s-OFDM_BPSK_Edge_1RB_Left_Low_CH

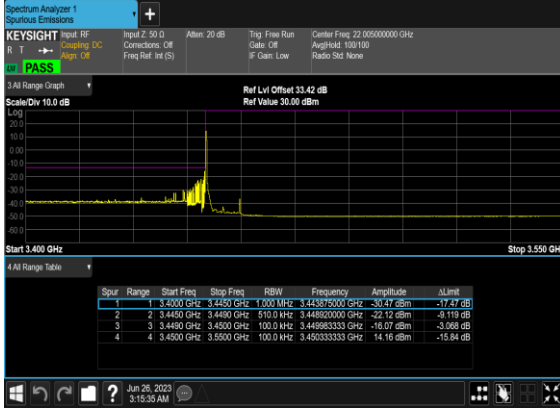

N78(10M)_DFT-s-OFDM_QPSK_Edge_1RB_Left_Low_CH

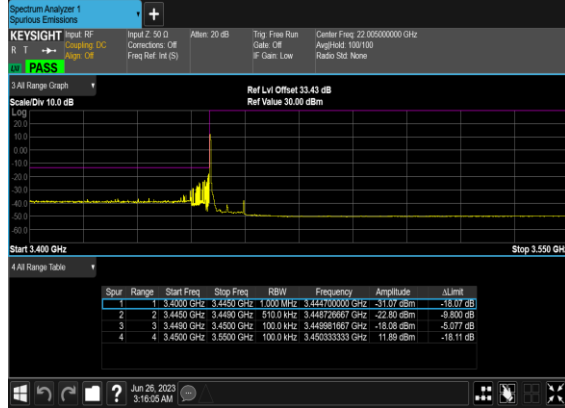

N78(10M)_DFT-s-OFDM_BPSK_Outer_Full_Low_CH

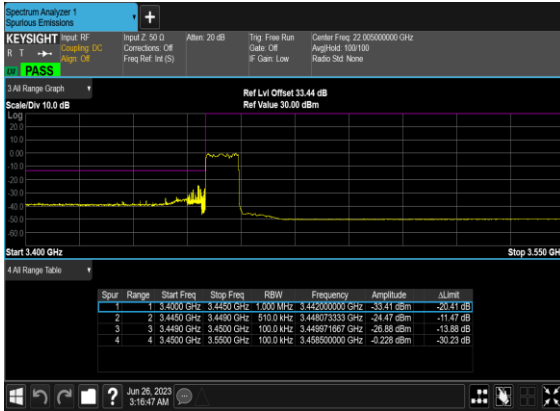

N78(10M)_DFT-s-OFDM_QPSK_Outer_Full_Low_CH

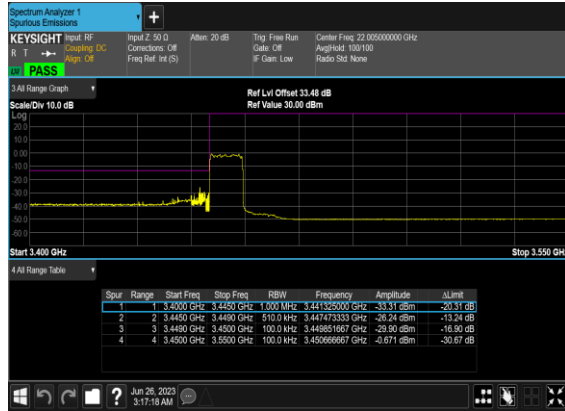

N78(10M)_DFT-s-OFDM_BPSK_Edge_1RB_Right_High_CH

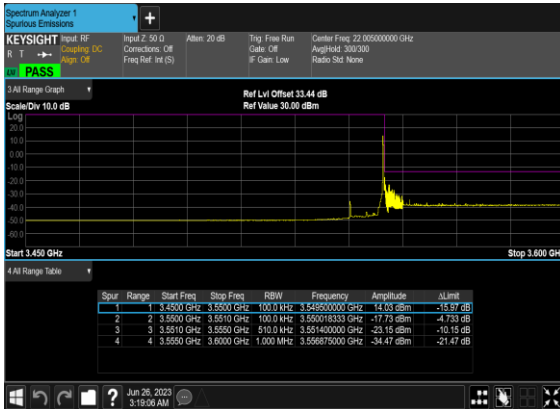

N78(10M)_DFT-s-OFDM_QPSK_Edge_1RB_Right_High_CH

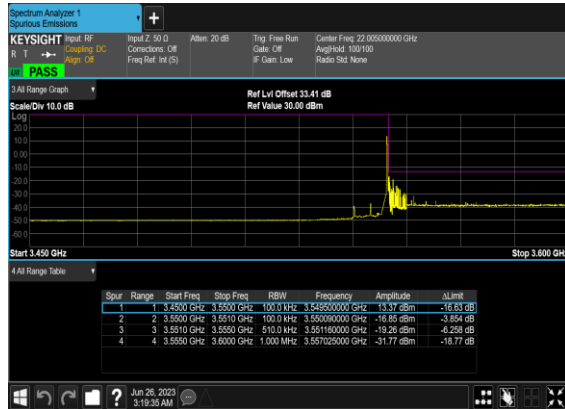

N78(10M)_DFT-s-OFDM_BPSK_Outer_Full_High_CH

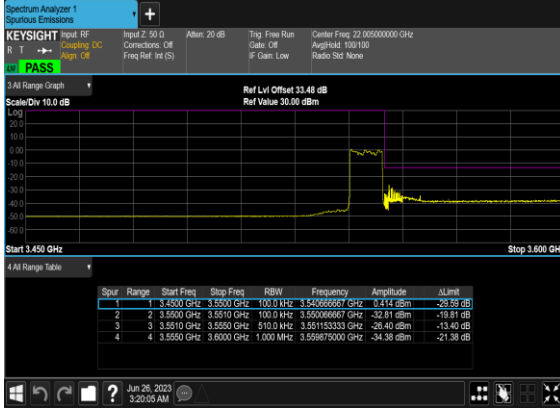

N78(10M)_DFT-s-OFDM_QPSK_Outer_Full_High_CH

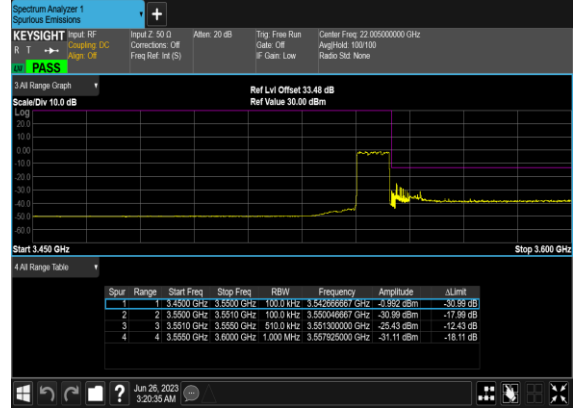

N78(30M)_DFT-s-OFDM_BPSK_Edge_1RB_Left_Low_CH



N78(30M)_DFT-s-OFDM_QPSK_Edge_1RB_Left_Low_CH

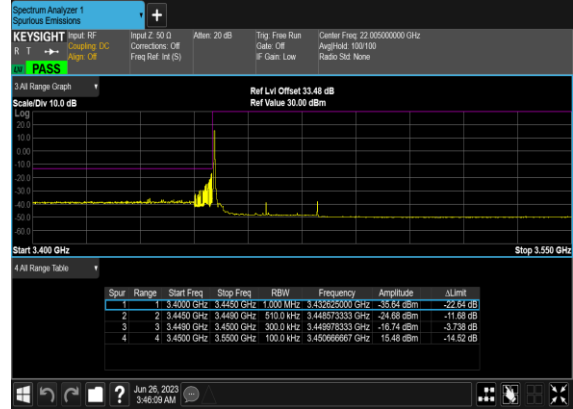

N78(30M)_DFT-s-OFDM_BPSK_Outer_Full_Low_CH

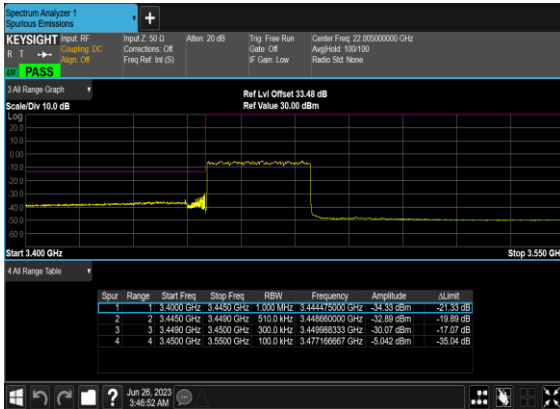

N78(30M)_DFT-s-OFDM_QPSK_Outer_Full_Low_CH

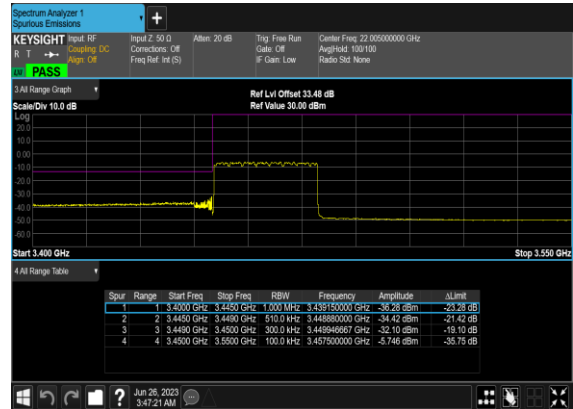

N78(30M)_DFT-s-OFDM_BPSK_Edge_1RB_Right_High_CH

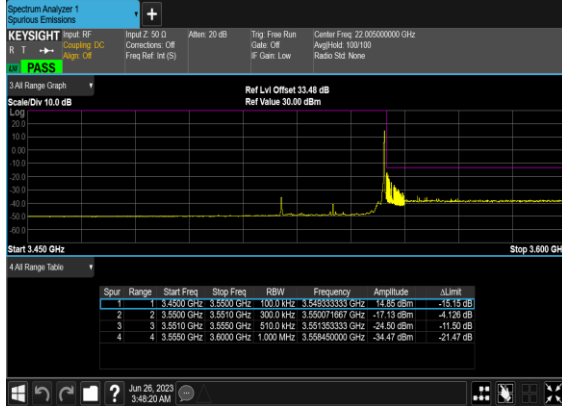

N78(30M)_DFT-s-OFDM_QPSK_Edge_1RB_Right_High_CH

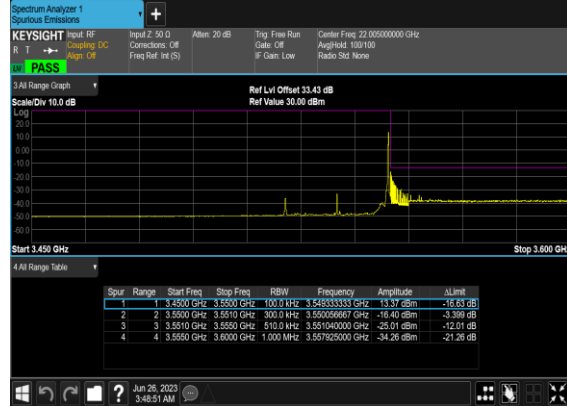

N78(30M)_DFT-s-OFDM_BPSK_Outer_Full_High_CH

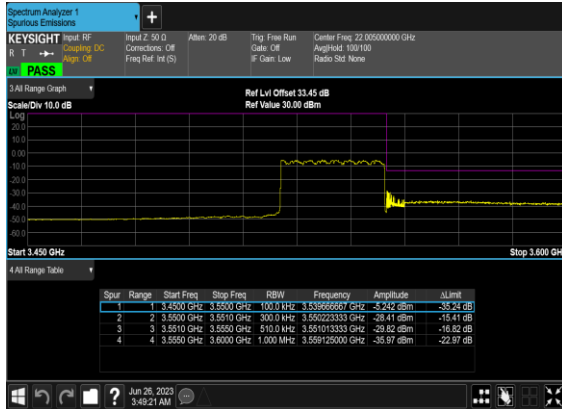

N78(30M)_DFT-s-OFDM_QPSK_Outer_Full_High_CH

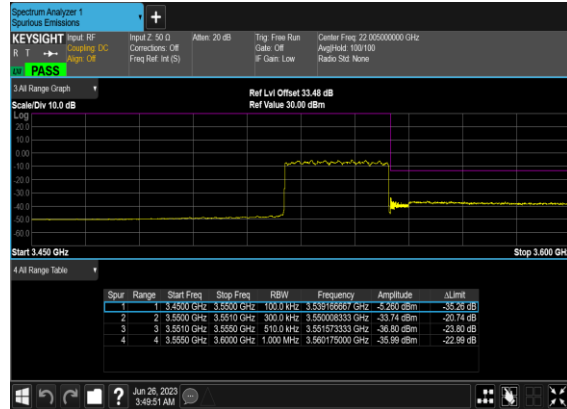

N78(50M)_DFT-s-OFDM_BPSK_Edge_1RB_Left_Low_CH

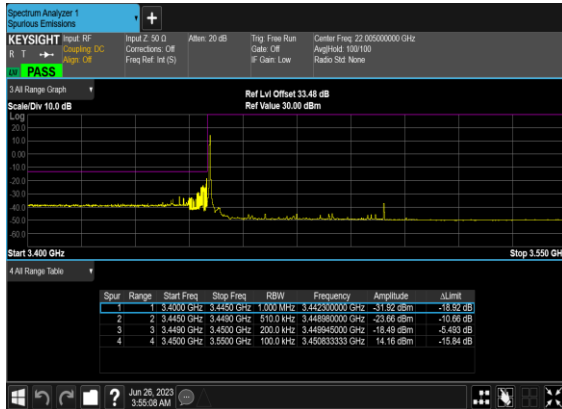

N78(50M)_DFT-s-OFDM_QPSK_Edge_1RB_Left_Low_CH

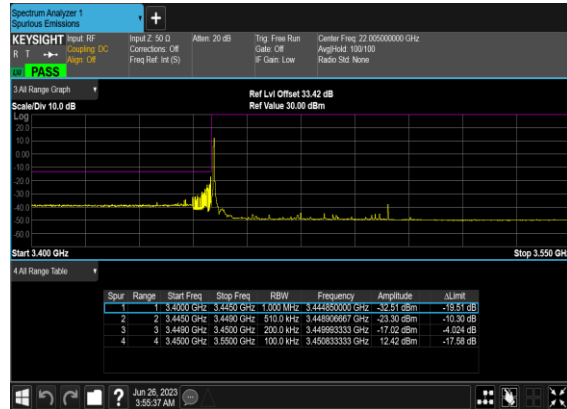

N78(50M)_DFT-s-OFDM_BPSK_Outer_Full_Low_CH

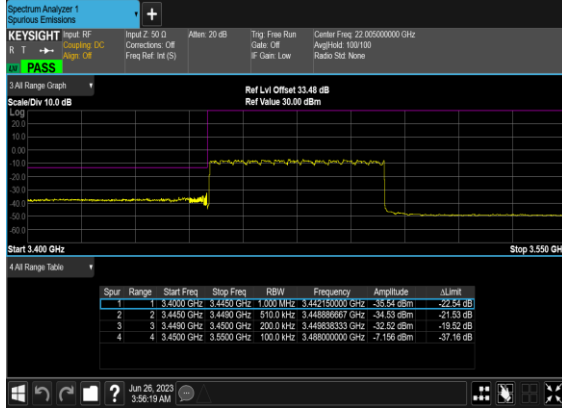

N78(50M)_DFT-s-OFDM_QPSK_Outer_Full_Low_CH

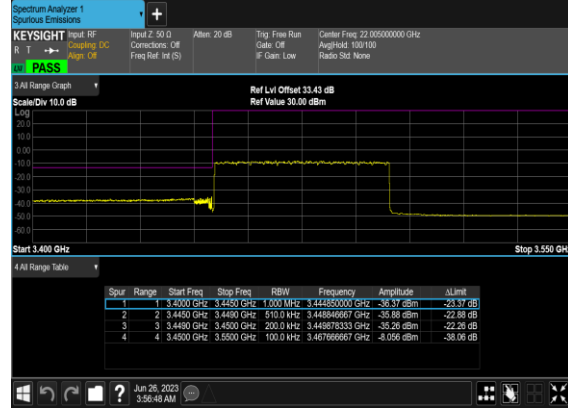

N78(50M)_DFT-s-OFDM_BPSK_Edge_1RB_Right_High_CH

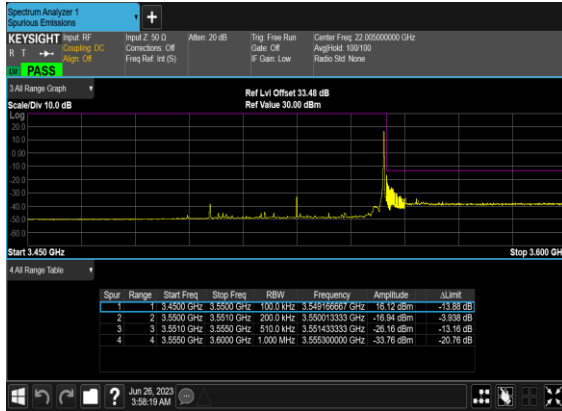

N78(50M)_DFT-s-OFDM_QPSK_Edge_1RB_Right_High_CH

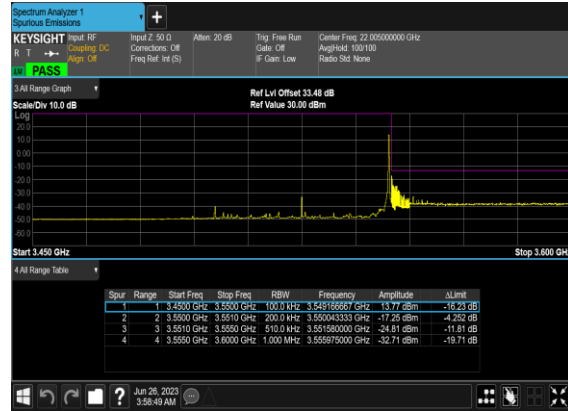

N78(50M)_DFT-s-OFDM_BPSK_Outer_Full_High_CH

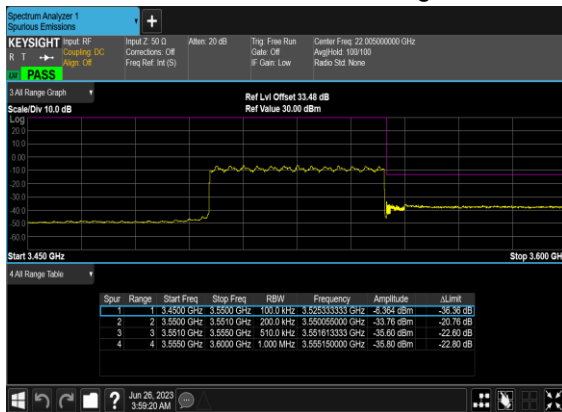

N78(50M)_DFT-s-OFDM_QPSK_Outer_Full_High_CH

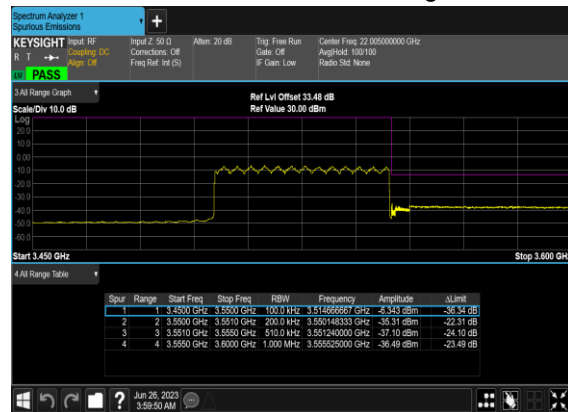

FR1 N78(ANT5)

Transmitter Conducted Output Power And EIRP, (G_T - L_C)=-3.71dB

NR Band	SCS	Band Width	Arfcn	Freq(MHz)	Modulation	RB	Conducted Power(dBm)	EIRP(dBm)	EIRP(W)
78	30	100	633334	3500.01	DFT-s-OFDM PI/2 BPSK	135@67	22.65	18.94	0.0783
78	30	100	633334	3500.01	DFT-s-OFDM PI/2 BPSK	1@1	22.32	18.61	0.0726
78	30	100	633334	3500.01	DFT-s-OFDM PI/2 BPSK	1@271	21.83	18.12	0.0649
78	30	100	633334	3500.01	DFT-s-OFDM QPSK	135@67	22.63	18.92	0.0780
78	30	100	633334	3500.01	DFT-s-OFDM QPSK	1@1	22.2	18.49	0.0706
78	30	100	633334	3500.01	DFT-s-OFDM QPSK	1@271	21.81	18.1	0.0646
78	30	100	633334	3500.01	DFT-s-OFDM 16 QAM	135@67	21.65	17.94	0.0622
78	30	100	633334	3500.01	DFT-s-OFDM 16 QAM	1@1	21.1	17.39	0.0548
78	30	100	633334	3500.01	DFT-s-OFDM 16 QAM	1@271	20.79	17.08	0.0511
78	30	100	633334	3500.01	DFT-s-OFDM 64 QAM	135@67	20.15	16.44	0.0441
78	30	100	633334	3500.01	DFT-s-OFDM 64 QAM	1@1	19.64	15.93	0.0392
78	30	100	633334	3500.01	DFT-s-OFDM 64 QAM	1@271	19.41	15.7	0.0372
78	30	100	633334	3500.01	DFT-s-OFDM 256 QAM	135@67	18.14	14.43	0.0277
78	30	100	633334	3500.01	DFT-s-OFDM 256 QAM	1@1	18.06	14.35	0.0272
78	30	100	633334	3500.01	DFT-s-OFDM 256 QAM	1@271	17.72	14.01	0.0252
78	30	100	633334	3500.01	CP-OFDM QPSK	137@68	21.11	17.4	0.0550
78	30	100	633334	3500.01	CP-OFDM QPSK	1@1	20.65	16.94	0.0494
78	30	100	633334	3500.01	CP-OFDM QPSK	1@271	20.36	16.65	0.0462
78	30	10	630334	3455.01	DFT-s-OFDM PI/2 BPSK	1@1	22.5	18.79	0.0757
78	30	10	630334	3455.01	DFT-s-OFDM QPSK	1@1	22.56	18.85	0.0767
78	30	10	630334	3455.01	DFT-s-OFDM 16 QAM	1@1	21.47	17.76	0.0597
78	30	10	633334	3500.01	DFT-s-OFDM PI/2 BPSK	1@1	22.54	18.83	0.0764
78	30	10	633334	3500.01	DFT-s-OFDM QPSK	1@1	22.6	18.89	0.0774
78	30	10	633334	3500.01	DFT-s-OFDM 16 QAM	1@1	21.48	17.77	0.0598
78	30	10	636332	3544.98	DFT-s-OFDM PI/2 BPSK	1@1	22.57	18.86	0.0769
78	30	10	636332	3544.98	DFT-s-OFDM QPSK	1@1	22.59	18.88	0.0773
78	30	10	636332	3544.98	DFT-s-OFDM 16 QAM	1@1	21.51	17.8	0.0603
78	30	15	630500	3457.5	DFT-s-OFDM PI/2 BPSK	1@1	22.52	18.81	0.0760

78	30	15	630500	3457.5	DFT-s-OFDM QPSK	1@1	22.54	18.83	0.0764
78	30	15	630500	3457.5	DFT-s-OFDM 16 QAM	1@1	21.48	17.77	0.0598
78	30	15	633334	3500.01	DFT-s-OFDM PI/2 BPSK	1@1	22.5	18.79	0.0757
78	30	15	633334	3500.01	DFT-s-OFDM QPSK	1@1	22.53	18.82	0.0762
78	30	15	633334	3500.01	DFT-s-OFDM 16 QAM	1@1	21.42	17.71	0.0590
78	30	15	636166	3542.49	DFT-s-OFDM PI/2 BPSK	1@1	22.58	18.87	0.0771
78	30	15	636166	3542.49	DFT-s-OFDM QPSK	1@1	22.59	18.88	0.0773
78	30	15	636166	3542.49	DFT-s-OFDM 16 QAM	1@1	21.52	17.81	0.0604
78	30	20	630668	3460.02	DFT-s-OFDM PI/2 BPSK	1@1	22.49	18.78	0.0755
78	30	20	630668	3460.02	DFT-s-OFDM QPSK	1@1	22.53	18.82	0.0762
78	30	20	630668	3460.02	DFT-s-OFDM 16 QAM	1@1	21.41	17.7	0.0589
78	30	20	633334	3500.01	DFT-s-OFDM PI/2 BPSK	1@1	22.46	18.75	0.0750
78	30	20	633334	3500.01	DFT-s-OFDM QPSK	1@1	22.51	18.8	0.0759
78	30	20	633334	3500.01	DFT-s-OFDM 16 QAM	1@1	21.38	17.67	0.0585
78	30	20	636000	3540	DFT-s-OFDM PI/2 BPSK	1@1	22.58	18.87	0.0771
78	30	20	636000	3540	DFT-s-OFDM QPSK	1@1	22.63	18.92	0.0780
78	30	20	636000	3540	DFT-s-OFDM 16 QAM	1@1	21.52	17.81	0.0604
78	30	30	631000	3465	DFT-s-OFDM PI/2 BPSK	1@1	22.4	18.69	0.0740
78	30	30	631000	3465	DFT-s-OFDM QPSK	1@1	22.44	18.73	0.0746
78	30	30	631000	3465	DFT-s-OFDM 16 QAM	1@1	21.31	17.6	0.0575
78	30	30	633334	3500.01	DFT-s-OFDM PI/2 BPSK	1@1	22.39	18.68	0.0738
78	30	30	633334	3500.01	DFT-s-OFDM QPSK	1@1	22.4	18.69	0.0740
78	30	30	633334	3500.01	DFT-s-OFDM 16 QAM	1@1	21.27	17.56	0.0570
78	30	30	635666	3534.99	DFT-s-OFDM PI/2 BPSK	1@1	22.45	18.74	0.0748
78	30	30	635666	3534.99	DFT-s-OFDM QPSK	1@1	22.5	18.79	0.0757
78	30	30	635666	3534.99	DFT-s-OFDM 16 QAM	1@1	21.4	17.69	0.0587
78	30	40	631334	3470.01	DFT-s-OFDM PI/2 BPSK	1@1	22.24	18.53	0.0713
78	30	40	631334	3470.01	DFT-s-OFDM QPSK	1@1	22.22	18.51	0.0710
78	30	40	631334	3470.01	DFT-s-OFDM 16 QAM	1@1	21.16	17.45	0.0556
78	30	40	633334	3500.01	DFT-s-OFDM PI/2 BPSK	1@1	22.17	18.46	0.0701
78	30	40	633334	3500.01	DFT-s-OFDM QPSK	1@1	22.21	18.5	0.0708
78	30	40	633334	3500.01	DFT-s-OFDM 16 QAM	1@1	21.09	17.38	0.0547
78	30	40	635332	3529.98	DFT-s-OFDM PI/2 BPSK	1@1	22.21	18.5	0.0708
78	30	40	635332	3529.98	DFT-s-OFDM QPSK	1@1	22.23	18.52	0.0711

78	30	40	635332	3529.98	DFT-s-OFDM 16 QAM	1@1	21.18	17.47	0.0558
78	30	50	631668	3475.02	DFT-s-OFDM PI/2 BPSK	1@1	22.53	18.82	0.0762
78	30	50	631668	3475.02	DFT-s-OFDM QPSK	1@1	22.56	18.85	0.0767
78	30	50	631668	3475.02	DFT-s-OFDM 16 QAM	1@1	21.44	17.73	0.0593
78	30	50	633334	3500.01	DFT-s-OFDM PI/2 BPSK	1@1	22.44	18.73	0.0746
78	30	50	633334	3500.01	DFT-s-OFDM QPSK	1@1	22.41	18.7	0.0741
78	30	50	633334	3500.01	DFT-s-OFDM 16 QAM	1@1	21.36	17.65	0.0582
78	30	50	635000	3525	DFT-s-OFDM PI/2 BPSK	1@1	22.56	18.85	0.0767
78	30	50	635000	3525	DFT-s-OFDM QPSK	1@1	22.61	18.9	0.0776
78	30	50	635000	3525	DFT-s-OFDM 16 QAM	1@1	21.51	17.8	0.0603
78	30	60	632000	3480	DFT-s-OFDM PI/2 BPSK	1@1	22.49	18.78	0.0755
78	30	60	632000	3480	DFT-s-OFDM QPSK	1@1	22.52	18.81	0.0760
78	30	60	632000	3480	DFT-s-OFDM 16 QAM	1@1	21.41	17.7	0.0589
78	30	60	633334	3500.01	DFT-s-OFDM PI/2 BPSK	1@1	22.33	18.62	0.0728
78	30	60	633334	3500.01	DFT-s-OFDM QPSK	1@1	22.36	18.65	0.0733
78	30	60	633334	3500.01	DFT-s-OFDM 16 QAM	1@1	21.21	17.5	0.0562
78	30	60	634666	3519.99	DFT-s-OFDM PI/2 BPSK	1@1	22.53	18.82	0.0762
78	30	60	634666	3519.99	DFT-s-OFDM QPSK	1@1	22.54	18.83	0.0764
78	30	60	634666	3519.99	DFT-s-OFDM 16 QAM	1@1	21.43	17.72	0.0592
78	30	70	632334	3485.01	DFT-s-OFDM PI/2 BPSK	1@1	22.47	18.76	0.0752
78	30	70	632334	3485.01	DFT-s-OFDM QPSK	1@1	22.47	18.76	0.0752
78	30	70	632334	3485.01	DFT-s-OFDM 16 QAM	1@1	21.42	17.71	0.0590
78	30	70	633334	3500.01	DFT-s-OFDM PI/2 BPSK	1@1	22.34	18.63	0.0729
78	30	70	633334	3500.01	DFT-s-OFDM QPSK	1@1	22.34	18.63	0.0729
78	30	70	633334	3500.01	DFT-s-OFDM 16 QAM	1@1	21.27	17.56	0.0570
78	30	70	634332	3514.98	DFT-s-OFDM PI/2 BPSK	1@1	22.47	18.76	0.0752
78	30	70	634332	3514.98	DFT-s-OFDM QPSK	1@1	22.48	18.77	0.0753
78	30	70	634332	3514.98	DFT-s-OFDM 16 QAM	1@1	21.36	17.65	0.0582
78	30	80	632668	3490.02	DFT-s-OFDM PI/2 BPSK	1@1	22.43	18.72	0.0745
78	30	80	632668	3490.02	DFT-s-OFDM QPSK	1@1	22.38	18.67	0.0736
78	30	80	632668	3490.02	DFT-s-OFDM 16 QAM	1@1	21.36	17.65	0.0582
78	30	80	633334	3500.01	DFT-s-OFDM PI/2 BPSK	1@1	22.3	18.59	0.0723
78	30	80	633334	3500.01	DFT-s-OFDM QPSK	1@1	22.31	18.6	0.0724
78	30	80	633334	3500.01	DFT-s-OFDM 16 QAM	1@1	21.21	17.5	0.0562

78	30	80	634000	3510	DFT-s-OFDM PI/2 BPSK	1@1	22.24	18.53	0.0713
78	30	80	634000	3510	DFT-s-OFDM QPSK	1@1	22.26	18.55	0.0716
78	30	80	634000	3510	DFT-s-OFDM 16 QAM	1@1	21.2	17.49	0.0561
78	30	90	633000	3495	DFT-s-OFDM PI/2 BPSK	1@1	22.31	18.6	0.0724
78	30	90	633000	3495	DFT-s-OFDM QPSK	1@1	22.35	18.64	0.0731
78	30	90	633000	3495	DFT-s-OFDM 16 QAM	1@1	21.24	17.53	0.0566
78	30	90	633334	3500.01	DFT-s-OFDM PI/2 BPSK	1@1	22.24	18.53	0.0713
78	30	90	633334	3500.01	DFT-s-OFDM QPSK	1@1	22.3	18.59	0.0723
78	30	90	633334	3500.01	DFT-s-OFDM 16 QAM	1@1	21.14	17.43	0.0553
78	30	90	633666	3504.99	DFT-s-OFDM PI/2 BPSK	1@1	22.19	18.48	0.0705
78	30	90	633666	3504.99	DFT-s-OFDM QPSK	1@1	22.26	18.55	0.0716
78	30	90	633666	3504.99	DFT-s-OFDM 16 QAM	1@1	21.1	17.39	0.0548

Frequency Stability

NR Band	SCS (kHz)	Bandwidth (MHz)	Arfcn	Freq (MHz)	Modulation	RB	Deviation (ppm)	Verdict	Environment
78	30	100	633334	3500.01	DFT-s-OFDM QPSK	270@0	0.0016	PASS	NV
78	30	100	633334	3500.01	DFT-s-OFDM QPSK	270@0	0.0013	PASS	LV
78	30	100	633334	3500.01	DFT-s-OFDM QPSK	270@0	-0.0009	PASS	HV
78	30	100	633334	3500.01	DFT-s-OFDM QPSK	270@0	0.0012	PASS	-30°C
78	30	100	633334	3500.01	DFT-s-OFDM QPSK	270@0	0.0026	PASS	-20°C
78	30	100	633334	3500.01	DFT-s-OFDM QPSK	270@0	0.0021	PASS	-10°C
78	30	100	633334	3500.01	DFT-s-OFDM QPSK	270@0	0.0014	PASS	0°C
78	30	100	633334	3500.01	DFT-s-OFDM QPSK	270@0	0.0028	PASS	10°C
78	30	100	633334	3500.01	DFT-s-OFDM QPSK	270@0	-0.0019	PASS	20°C
78	30	100	633334	3500.01	DFT-s-OFDM QPSK	270@0	0.0024	PASS	30°C
78	30	100	633334	3500.01	DFT-s-OFDM QPSK	270@0	0.0033	PASS	40°C
78	30	100	633334	3500.01	DFT-s-OFDM QPSK	270@0	0.0026	PASS	50°C

Peak to Average Ratio

NR Band	SCS (kHz)	Bandwidth (MHz)	Arfcn	Freq (MHz)	Modulation	RB	Result (dB)	Limit (dB)	Verdict
78	30	100	633334	3500.01	DFT-s-OFDM PI/2 BPSK	270@0	10.17	13	PASS
78	30	100	633334	3500.01	DFT-s-OFDM PI/2 BPSK	1@0	7.11	13	PASS
78	30	100	633334	3500.01	DFT-s-OFDM QPSK	270@0	10.55	13	PASS
78	30	100	633334	3500.01	DFT-s-OFDM QPSK	1@0	7.91	13	PASS