



FCC RF Test Report

APPLICANT : Motorola Mobility LLC
EQUIPMENT : Mobile Cellular Phone
BRAND NAME : Motorola
MODEL NAME : XT2305-1
FCC ID : IHDT56AL5
STANDARD : 47 CFR Part 2, 96
CLASSIFICATION : Citizens Band End User Devices (CBE)
EQUIPMENT TYPE : End User Equipment
TEST DATE(S) : Mar. 16, 2023 ~ Apr. 16, 2023

We, Sporton International Inc. (Kunshan), would like to declare that the tested sample has been evaluated in accordance with the procedures given in ANSI C63.26 and shown compliance with the applicable technical standards.

This report contains data that were produced under subcontract by Sporton International Inc. (Shenzhen)

The test results in this report apply exclusively to the tested model / sample. Without written approval of Sporton International Inc. (Kunshan), the test report shall not be reproduced except in full.

Jason Jia



Approved by: Jason Jia

Sporton International Inc. (Kunshan)

**No. 1098, Pengxi North Road, Kunshan Economic Development Zone Jiangsu Province 215300
People's Republic of China**



Table of Contents

History of this test report.....	3
Summary of Test Result.....	4
1 General Description	5
1.1 Applicant.....	5
1.2 Manufacturer	5
1.3 Feature of Equipment Under Test.....	5
1.4 Specification of Accessory	6
1.5 Maximum EIRP Power and Emission Designator	6
1.6 Testing Site.....	7
1.7 Test Software	7
1.8 Applied Standards	8
2 Test Configuration of Equipment Under Test	9
2.1 Test Mode.....	9
2.2 Connection Diagram of Test System	11
2.3 Support Unit used in test configuration	11
2.4 Measurement Results Explanation Example	11
2.5 Frequency List of Low/Middle/High Channels.....	12
3 Conducted Test Items	14
3.1 Measuring Instruments.....	14
3.2 Conducted Output Power	15
3.3 EIRP	16
3.4 Occupied Bandwidth	17
3.5 Conducted Band Edge	18
3.6 Conducted Spurious Emission	19
3.7 Frequency Stability.....	20
4 Radiated Test Items	21
4.1 Measuring Instruments.....	21
4.2 Test Setup	21
4.3 Test Result of Radiated Test.....	22
4.4 Radiated Spurious Emission	23
5 List of Measuring Equipment.....	24
6 Uncertainty of Evaluation	25
Appendix A. Test Results of Conducted Test	
Appendix B. Test Results of Radiated Test	
Appendix C. Test Setup Photographs	



Summary of Test Result

Report Clause	Ref Std. Clause	Test Items	Result (PASS/FAIL)	Remark
3.2	§2.1046	Conducted Output Power	Reporting only	-
-	§96.41	Peak-to-Average Ratio	Not Applicable	Not applicable for End User Devices
3.3	§96.41	Maximum E.I.R.P	Pass	-
		Maximum Power Spectral Density	Not Applicable	Not applicable for End User Devices
3.4	§2.1049 §96.41	Occupied Bandwidth	Reporting only	-
3.5	§2.1051 §96.41	Conducted Band Edge Measurement Adjacent Channel Leakage Ratio	Pass	-
3.6	§2.1051 §96.41	Conducted Spurious Emission	Pass	-
3.7	§2.1055	Frequency Stability for Temperature & Voltage	Pass	-
4.4	§2.1051 §96.41	Radiated Spurious Emission	Pass	Under limit 15.64 dB at 14724.00 MHz

Declaration of Conformity:

The test results with all measurement uncertainty excluded are presented in accordance with the regulation limits or requirements declared by manufacturers.

Comments and Explanations:

The declared of product specification for EUT presented in the report are provided by the manufacturer, and the manufacturer takes all the responsibilities for the accuracy of product specification.



1 General Description

1.1 Applicant

Motorola Mobility LLC
222 W,Merchandise Mart Plaza, Chicago IL 60654 USA

1.2 Manufacturer

Motorola Mobility LLC
222 W,Merchandise Mart Plaza, Chicago IL 60654 USA

1.3 Feature of Equipment Under Test

Product Feature	
Equipment	Mobile Cellular Phone
Brand Name	Motorola
Model Name	XT2305-1
FCC ID	IHDT56AL5
Tx Frequency	LTE Band 48: 3550 MHz ~ 3700 MHz
Rx Frequency	LTE Band 48: 3550 MHz ~ 3700 MHz
Bandwidth	5MHz / 10MHz / 15MHz / 20MHz
Maximum Output Power to Antenna	LTE Band 48: <Ant.2>: 22.83 dBm <Ant.4>: 23.24 dBm <Ant.5>: 22.89 dBm <Ant.7>: 22.91 dBm LTE Band 48B: <Ant.4>: 22.69 dBm LTE Band 48C: <Ant.2>: 22.63 dBm
Antenna Gain	<Ant.2>: -5.5 dBi <Ant.4>: -5.0 dBi <Ant.5>: -9.5 dBi <Ant.7>: -7.0 dBi
Type of Modulation	QPSK / 16QAM / 64QAM / 256QAM
IMEI Code	Conducted: 351048560017430/351048560017448 Radiation: 351048560019691
HW Version	DVT2
SW Version	TTT33.46
EUT Stage	Identical Prototype

Remark:

1. The above EUT's information was declared by manufacturer. Please refer to the specifications or user's manual for more detailed description.
2. The maximum EIRP is calculated from max output power and max antenna gain, so only the maximum EIRP of Ant.4 for LTE Band48/48B and Ant.2 for LTE Band 48C are shown in the report.

1.4 Specification of Accessory

Specification of Accessory				
AC Adapter 1(US)	Brand Name	Motorola (Chenyang)	Model Name	MC-681N
AC Adapter 2(US)	Brand Name	Motorola (Acbel)	Model Name	MC-681N
Battery 1	Brand Name	Motorola(AmpereX)	Model Name	PG44
USB Cable 1	Brand Name	Motorola(Saibao)	Model Name	SC18D86731
USB Cable 2	Brand Name	Motorola(Saibao)	Model Name	SC18D71644

1.5 Maximum EIRP Power and Emission Designator

LTE Band 48		QPSK		16QAM/64QAM/256QAM	
BW (MHz)	Frequency Range (MHz)	Maximum EIRP(W)	Emission Designator (99%OBW)	Maximum EIRP(W)	Emission Designator (99%OBW)
5	3552.5~3697.5	0.0656	4M49G7D	0.0536	4M53W7D
10	3555~3695	0.0647	9M03G7D	0.0545	9M11W7D
15	3557.5~3692.5	0.0655	13M4G7D	0.0536	13M5W7D
20	3560~3690	0.0667	17M9G7D	0.0548	17M9W7D

LTE Band 48B_CA		QPSK		16QAM/64QAM/256QAM	
BW (MHz)	Frequency (MHz)	Maximum EIRP(W)	Emission Designator (99%OBW)	Maximum EIRP(W)	Emission Designator (99%OBW)
10MHz+10MHz	(3555 ~ 3695 MHz)	0.0587	18M7G7D	0.0468	18M8W7D

LTE Band 48C_CA		QPSK		16QAM/64QAM/256QAM	
BW (MHz)	Frequency (MHz)	Maximum EIRP(W)	Emission Designator (99%OBW)	Maximum EIRP(W)	Emission Designator (99%OBW)
5MHz+20MHz	(3553.5 ~ 3690 MHz)	0.0497	23M4G7D	0.0405	23M2W7D
10MHz+20MHz	(3555.5 ~ 3690 MHz)	0.0494	27M9G7D	0.0419	28M0W7D
15MHz+20MHz	(3557.8 ~ 3690 MHz)	0.0506	32M7G7D	0.0419	32M9W7D
20MHz+5MHz	(3560 ~ 3696.7 MHz)	0.0516	23M4G7D	0.0407	23M2W7D
20MHz+10MHz	(3560 ~ 3694.5 MHz)	0.0493	28M0G7D	0.0406	28M1W7D
20MHz+15MHz	(3560 ~ 3692.2 MHz)	0.0506	32M9G7D	0.0411	32M8W7D
20MHz+20MHz	(3560 ~ 3690 MHz)	0.0512	37M4G7D	0.0409	37M6W7D

Note: All modulations have been tested, only the worst test results of PSK & QAM are shown in the report.



1.6 Testing Site

Sporton International Inc. (Kunshan) is accredited to ISO/IEC 17025:2017 by American Association for Laboratory Accreditation with Certificate Number 5145.02.

Test Firm	Sporton International Inc. (Kunshan)		
Test Site Location	No. 1098, Pengxi North Road, Kunshan Economic Development Zone Jiangsu Province 215300 People's Republic of China TEL : +86-512-57900158		
Test Site No.	Sporton Site No.	FCC Designation No.	FCC Test Firm Registration No.
	03CH05-KS TH01-KS	CN1257	314309

Sporton International Inc. (ShenZhen) is accredited to ISO/IEC 17025:2017 by American Association for Laboratory Accreditation with Certificate Number 5145.01.

Test Firm	Sporton International Inc. (ShenZhen)		
Test Site Location	1/F, 2/F, Bldg 5, Shiling Industrial Zone, Xinwei Village, Xili, Nanshan, Shenzhen, 518055 People's Republic of China TEL: +86-755-86379589 FAX: +86-755-86379595		
Test Site No.	Sporton Site No.	FCC Designation No.	FCC Test Firm Registration No.
	TH01-SZ	CN1256	421272

Test data subcontracted: Conducted test case in section 3.2~3.7 of this report.

1.7 Test Software

Item	Site	Manufacturer	Name	Version
1.	03CH05-KS	AUDIX	E3	6.2009-8-24



1.8 Applied Standards

According to the specifications of the manufacturer, the EUT must comply with the requirements of the following standards:

- ♦ ANSI C63.26-2015
- ♦ 47 CFR Part 2, 96
- ♦ FCC KDB 971168 D01 Power Meas. License Digital Systems v03r01
- ♦ FCC KDB 940660 D01 Part 96 CBRS v03
- ♦ FCC KDB 412172 D01 Determining ERP and EIRP v01r01

Remark:

1. All test items were verified and recorded according to the standards and without any deviation during the test.
2. This EUT has also been tested and complied with the requirements of FCC Part 15, Subpart B, recorded in a separate test report.



2 Test Configuration of Equipment Under Test

2.1 Test Mode

Antenna port conducted and radiated test items listed below are performed according to KDB 971168 D01 Power Meas. License Digital Systems v03r01 with maximum output power.

For radiated measurement, pre-scanned in three orthogonal panels, X, Y, Z. The worst cases (X plane) were recorded in this report.

Test Items	Band	Bandwidth (MHz)						Modulation				RB #			Test Channel			
		1.4	3	5	10	15	20	QPSK	16QAM	64QAM	256QAM	1	Half	Full	L	M	H	
Max. Output Power	48	-	-	v	v	v	v	v	v	v	v	v			v	v	v	v
26dB and 99% Bandwidth	48	-	-	v	v	v	v	v	v	v					v	v	v	v
Conducted Band Edge	48	-	-	v	v	v	v	v	v	v				v	v	v	v	v
Conducted Spurious Emission	48	-	-	v	v	v	v	v	v	v				v	v	v	v	v
ACLR	48	-	-	v	v	v	v	v	v	v				v	v	v	v	v
E.I.R.P.	48	-	-	v	v	v	v	v	v	v	v			v	v	v	v	v
Frequency Stability	48	-	-		v			v						v			v	
Radiated Spurious Emission	48	Worst Case													v	v	v	
Remark	<ol style="list-style-type: none"> The mark "v" means that this configuration is chosen for testing The mark "-" means that this bandwidth is not supported. The device is investigated from 30MHz to 10 times of fundamental signal for radiated spurious emission test under different RB size/offset and modulations in exploratory test. Subsequently, only the worst case emissions are reported. 																	



Test Items	Band	Bandwidth (MHz)								Modulation				RB #			Test Channel		
		20+20	20+15	15+20	20+10	10+20	10+10	20+5	5+20	QPSK	16QAM	64QAM	256 QAM	1	Half	Full	L	M	H
Max. Output Power	48C	v	v	v	v	v	-	v	v	v	v	v	v	v			v	v	v
	48B	-	-	-	-	-	v	-	-	v	v	v	v	v			v	v	v
26dB and 99% Bandwidth	48C	v	v	v	v	v	-	v	v	v	v						v		v
	48B	-	-	-	-	-	v	-	-	v	v						v		v
Conducted Band Edge	48C	v	v	v	v	v	-	v	v	v	v	v		v			v	v	v
	48B	-	-	-	-	-	v	-	-	v	v	v		v			v	v	v
Conducted Spurious Emission	48C	v	v	v	v	v	-	v	v	v				v			v	v	v
	48B	-	-	-	-	-	v	-	-	v				v			v	v	v
Adjacent Channel Leakage Ratio	48C	v	v	v	v	v	-	v	v	v	v	v		v			v	v	v
	48B	-	-	-	-	-	v	-	-	v	v	v		v			v	v	v
E.I.R.P.	48C	v	v	v	v	v	-	v	v	v	v	v	v	v			v	v	v
	48B	-	-	-	-	-	v	-	-	v	v	v	v	v			v	v	v
Frequency Stability	48C	v					-			v				v					v
	48B	-	-	-	-	-	v	-	-	v				v					v
Radiated Spurious Emission	48C	Worst Case														v	v	v	
	48B	Worst Case														v	v	v	
Note	1. The mark "v" means that this configuration is chosen for testing 2. The mark "-" means that this bandwidth is not supported. 3. The device is investigated from 30MHz to 10 times of fundamental signal for radiated spurious emission test under different RB size/offset and modulations in exploratory test. Subsequently, only the worst case emissions are reported. 4. All test items are based on engineering evaluation.																		

2.2 Connection Diagram of Test System

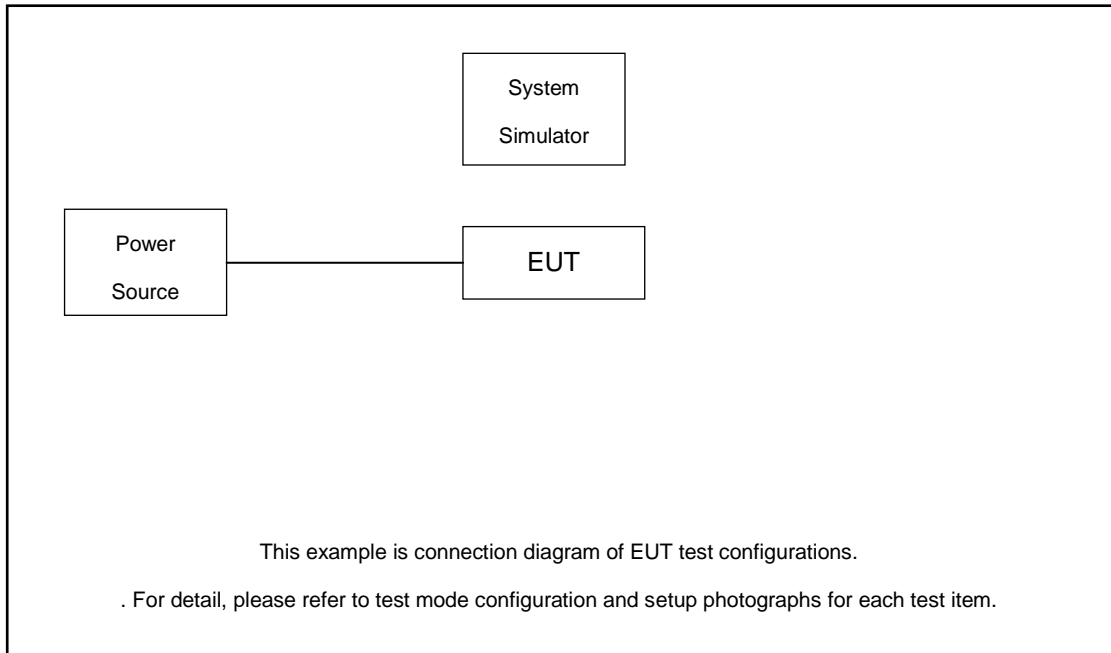

2.3 Support Unit used in test configuration

Item	Equipment	Trade Name	Model No.	FCC ID	Data Cable	Power Cord
1.	Power Supply	GWINSTEK	PSS-2002	N/A	N/A	Unshielded, 1.8 m
2.	LTE Base Station	Anritsu	MT8821C	N/A	N/A	Unshielded, 1.8 m
3.	Fixture	INTEL	NGFF Card Carrier	N/A	N/A	N/A

2.4 Measurement Results Explanation Example

For all conducted test items:

The offset level is set in the spectrum analyzer to compensate the RF cable loss and attenuator factor between EUT conducted output port and spectrum analyzer. With the offset compensation, the spectrum analyzer reading level is exactly the EUT RF output level.

The spectrum analyzer offset is derived from RF cable loss and attenuator factor.

Offset = RF cable loss + attenuator factor.

Following shows an offset computation example with cable loss 5.5 dB and 10dB attenuator.

Example :

$$\begin{aligned} \text{Offset(dB)} &= \text{RF cable loss(dB)} + \text{attenuator factor(dB)} \\ &= 5.5 + 10 = 15.5 \text{ (dB)} \end{aligned}$$



2.5 Frequency List of Low/Middle/High Channels

LTE Band 48 Channel and Frequency List				
BW [MHz]	Channel/Frequency(MHz)	Lowest	Middle	Highest
20	Channel	55340	55990	56640
	Frequency	3560.0	3625.0	3690.0
15	Channel	55315	55990	56665
	Frequency	3557.5	3625.0	3692.5
10	Channel	55290	55990	56690
	Frequency	3555.0	3625.0	3695.0
5	Channel	55265	55990	56715
	Frequency	3552.5	3625.0	3697.5

LTE Band 48B_CA Channel and Frequency List					
BW [MHz]	Channel/Frequency(MHz)	Lowest	Middle	Highest	
10 + 10	PCC	Channel	55290	55941	56591
		Frequency	3555	3620.1	3685.1
	SCC	Channel	55389	56039	56690
		Frequency	3564.9	3629.9	3695



LTE Band 48C_CA Channel and Frequency List					
BW [MHz]	Channel/Frequency(MHz)		Lowest	Middle	Highest
5 + 20	PCC	Channel	55273	55898	56523
		Frequency	3553.3	3615.8	3678.3
	SCC	Channel	55390	56015	56640
		Frequency	3565	3627.5	3690
20 + 5	PCC	Channel	55340	55965	56590
		Frequency	3560	3622.5	3685
	SCC	Channel	55457	56082	56707
		Frequency	3571.7	3634.2	3696.7
10 + 20	PCC	Channel	55295	55896	56496
		Frequency	3555.5	3615.6	3675.6
	SCC	Channel	55439	56040	56640
		Frequency	3569.9	3630	3690
20 + 10	PCC	Channel	55340	55941	56541
		Frequency	3560	3620.1	3680.1
	SCC	Channel	55484	56085	56685
		Frequency	3574.4	3634.5	3694.5
15 + 20	PCC	Channel	55318	55893	56469
		Frequency	3557.8	3615.3	3672.9
	SCC	Channel	55489	56064	56640
		Frequency	3574.9	3632.4	3690
20 + 15	PCC	Channel	55340	55916	56491
		Frequency	3560	3617.6	3675.1
	SCC	Channel	55511	56087	56662
		Frequency	3577.1	3634.7	3692.2
20 + 20	PCC	Channel	55340	55891	56442
		Frequency	3560	3615.1	3670.2
	SCC	Channel	55538	56089	56640
		Frequency	3579.8	3634.9	3690

3 Conducted Test Items

3.1 Measuring Instruments

See list of measuring instruments of this test report.

3.1.1 Test Setup

3.1.2 Conducted Output Power

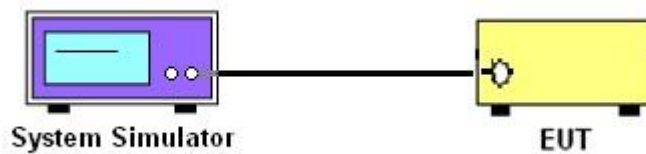

3.1.3 PSD, Peak-to-Average Ratio, Occupied Bandwidth, Conducted Band-Edge and Conducted Spurious Emission

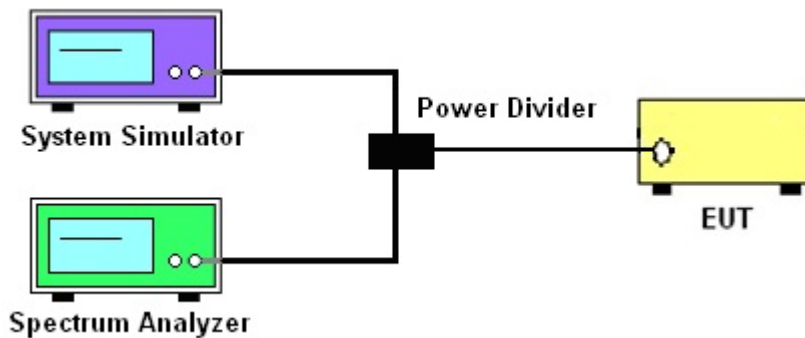

3.1.4 Frequency Stability

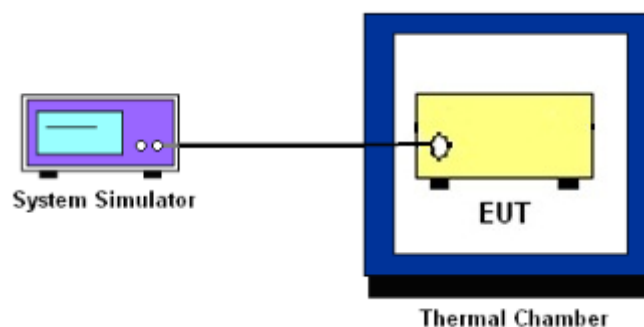

3.1.5 Test Result of Conducted Test

Please refer to Appendix A.



3.2 Conducted Output Power

3.2.1 Description of the Conducted Output Power Measurement

A system simulator was used to establish communication with the EUT. Its parameters were set to force the EUT transmitting at maximum output power. The measured power in the radio frequency on the transmitter output terminals shall be reported.

3.2.2 Test Procedures

1. The transmitter output port was connected to the system simulator.
2. Set EUT at maximum power through the system simulator.
3. Select lowest, middle, and highest channels for each band and different modulation.
4. Measure and record the power level from the system simulator.

3.3 EIRP

3.3.1 Description of the EIRP Measurement

EIRP limits for CBRS equipment as below table:

Device		Maximum EIRP (dBm/10 MHz)	Maximum PSD (dBm/MHz)
Applied	End User Device	23	n/a
<input type="checkbox"/>	Category A CBSD	30	20
<input type="checkbox"/>	Category B CBSD	47	37

Remark: The worst case EIRP shown in this section is found with LTE operating only using 1RB. As such, the EIRP/10MHz and full channel EIRP values will be identical since 1RB is fully contained within all available channel bandwidths for LTE Band 48 (i.e. 5, 10, 15, 20MHz)

3.3.2 Test Procedures for EIRP

1. Establishing a communications link with the call box (Base station) to measure the Maximum conducted power, the parameters were set to force the EUT transmitting at maximum output power level. Use the average power measurement function to measure total channel power of each channel bandwidth (per ANSI C63.26-2015 Section 5.2.1)
2. Determining ERP and/or EIRP from conducted RF output power measurements (Per ANSI C63.26-2015 Section 5.2.5.5)
 - EIRP = $P_T + G_T - L_C$, ERP = EIRP -2.15, where
 - P_T = transmitter output power in dBm
 - G_T = gain of the transmitting antenna in dBi
 - L_C = signal attenuation in the connecting cable between the transmitter and antenna in dB



3.4 Occupied Bandwidth

3.4.1 Description of Occupied Bandwidth Measurement

The occupied bandwidth is the width of a frequency band such that, below the lower and above the upper frequency limits, the mean powers emitted are each equal to a specified percentage 0.5% of the total mean transmitted power.

The 26 dB emission bandwidth is defined as the frequency range between two points, one above and one below the carrier frequency, at which the spectral density of the emission is attenuated 26 dB below the maximum in-band spectral density of the modulated signal. Spectral density (power per unit bandwidth) is to be measured with a detector of resolution bandwidth equal to approximately 1.0% of the emission bandwidth.

3.4.2 Test Procedures

The testing follows ANSI C63.26-2015 Section 5.4.3 (26dB) and Section 5.4.4 (99OB)

1. The EUT was connected to spectrum analyzer and system simulator via a power divider.
2. The spectrum analyzer center frequency is set to the nominal EUT channel center frequency. The span range for the spectrum analyzer shall be between two and five times the anticipated OBW.
3. The nominal resolution bandwidth (RBW) shall be in the range of 1 to 5 % of the anticipated OBW, and the VBW shall be at least 3 times the RBW.
4. Set the detection mode to peak, and the trace mode to max hold.
5. Determine the reference value: Set the EUT to transmit a modulated signal. Allow the trace to stabilize. Set the spectrum analyzer marker to the highest level of the displayed trace.
(this is the reference value)
6. Determine the “-26 dB down amplitude” as equal to (Reference Value – X).
7. Place two markers, one at the lowest and the other at the highest frequency of the envelope of the spectral display such that each marker is at or slightly below the “-X dB down amplitude” determined in step 6. If a marker is below this “-X dB down amplitude” value it shall be placed as close as possible to this value. The OBW is the positive frequency difference between the two markers.
8. Use the 99 % power bandwidth function of the spectrum analyzer and report the measured bandwidth.

3.5 Conducted Band Edge

3.5.1 Description of Conducted Band Edge Measurement

Part 96.41 (e) (1) (i)

For CBSD the emission limits outside the fundamental are as follows:

Within 0 MHz to 10 MHz above and below the assigned channel ≤ -13 dBm/MHz

Greater than 10 MHz above and below the assigned channel ≤ -25 dBm/MHz

Part 96.41 (e) (1) (ii)

For End User Devices the emission limits outside the fundamental are as follows:

Within 0 MHz to B MHz above and below the assigned channel ≤ -13 dBm/MHz

Greater than B MHz above and below the assigned channel ≤ -25 dBm/MHz

where B is the bandwidth in megahertz of the assigned channel or multiple contiguous channels of the End User Device.

Notwithstanding the emission limits in this paragraph, the Adjacent Channel Leakage Ratio for End User Devices shall be at least 30 dB.

Part 96.41 (e) (2)

For CBSDs and End User Devices, the conducted power of emissions below 3540 MHz or above 3710 MHz shall not exceed -25 dBm/MHz, and the conducted power of emissions below 3530 MHz or above 3720 MHz shall not exceed -40 dBm/MHz

3.5.2 Test Procedures

The testing follows FCC KDB 971168 D01 v03r01 Section 6.1.

1. The EUT was connected to spectrum analyzer and system simulator via a power divider.
2. The band edges of low and high channels for the highest RF powers were measured.
3. Set RBW $\geq 1\%$ EBW in the 1MHz band immediately outside and adjacent to the band edge.
4. Beyond the 1 MHz band from the band edge, RBW=1MHz was used
5. Offset has included the duty factor for LTE Band 48. Duty factor $=10 \log (1/x)$, where x is the measured duty cycle.
6. Set spectrum analyzer with RMS detector.
7. The RF fundamental frequency should be excluded against the limit line in the operating frequency band.



3.6 Conducted Spurious Emission

3.6.1 Description of Conducted Spurious Emission Measurement

96.41 (e)(2)

The conducted power of any emissions below 3530 MHz or above 3720 MHz shall not exceed -40dBm/MHz.

3.6.2 Test Procedures

The testing follows FCC KDB 971168 D01 v03r01 Section 6.1.

1. The EUT was connected to spectrum analyzer and system simulator via a power divider.
2. The RF output of EUT was connected to the spectrum analyzer by RF cable and attenuator. The path loss was compensated to the results for each measurement.
3. The middle channel for the highest RF power within the transmitting frequency was measured.
4. The conducted spurious emission for the whole frequency range was taken.
5. Make the measurement with the spectrum analyzer's RBW = 1MHz, VBW = 3MHz.
6. Set spectrum analyzer with RMS detector.
7. Taking the record of maximum spurious emission.
8. The RF fundamental frequency should be excluded against the limit line in the operating frequency band.
9. The limit line is -40dBm/MHz.

3.7 Frequency Stability

3.7.1 Description of Frequency Stability Measurement

The frequency stability shall be measured by variation of ambient temperature and variation of primary supply voltage to ensure that the fundamental emission stays within the authorized frequency block. The frequency stability of the transmitter shall be maintained within $\pm 0.00025\%$ ($\pm 2.5\text{ppm}$) of the center frequency

3.7.2 Test Procedures for Temperature Variation

The testing follows FCC KDB 971168 D01 v03r01 Section 9.0.

1. The EUT was set up in the thermal chamber and connected with the system simulator.
2. With power OFF, the temperature was decreased to -30°C and the EUT was stabilized before testing. Power was applied and the maximum change in frequency was recorded within one minute.
3. With power OFF, the temperature was raised in 10°C step up to 50°C . The EUT was stabilized at each step for at least half an hour. Power was applied and the maximum frequency change was recorded within one minute.

3.7.3 Test Procedures for Voltage Variation

The testing follows FCC KDB 971168 D01 v03r01 Section 9.0.

1. The EUT was placed in a temperature chamber at $25\pm 5^{\circ}\text{C}$ and connected with the system simulator.
2. The power supply voltage to the EUT was varied from 85% to 115% of the nominal value measured at the input to the EUT.
3. The variation in frequency was measured for the worst case.

4 Radiated Test Items

4.1 Measuring Instruments

See list of measuring instruments of this test report.

4.2 Test Setup

4.2.1 For radiated test below 30MHz

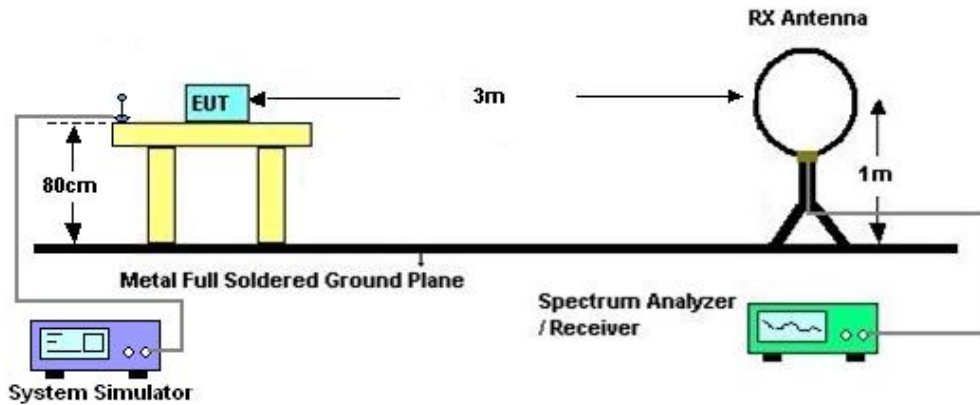

4.2.2 For radiated test from 30MHz to 1GHz

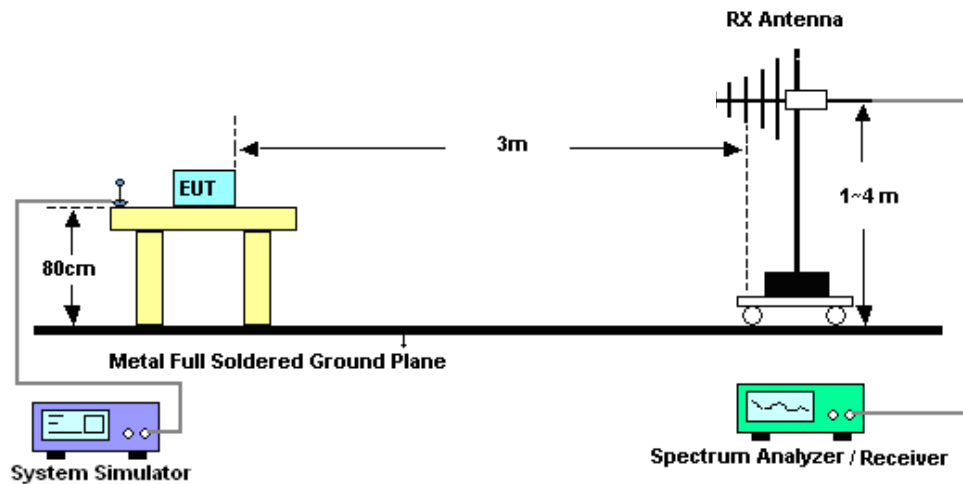

4.2.3 For radiated test above 1GHz

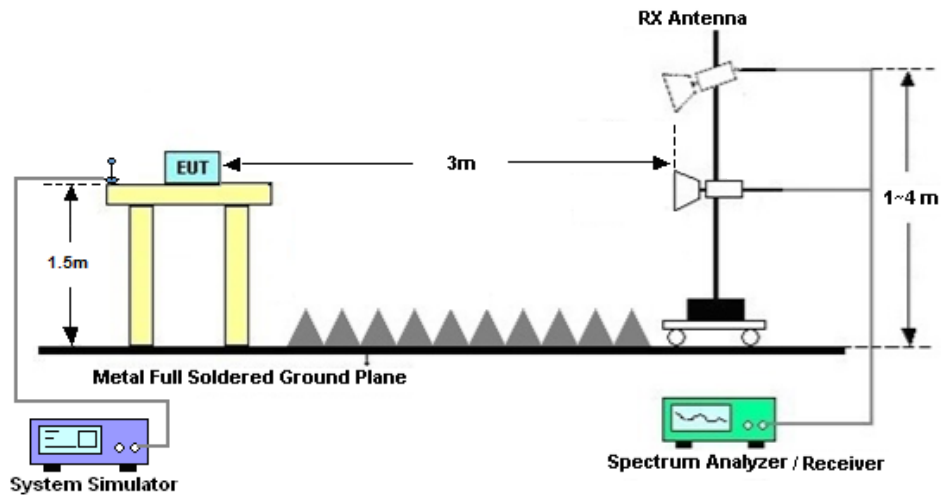

4.3 Test Result of Radiated Test

The low frequency, which started from 9 kHz to 30MHz, was pre-scanned and the result which was 20dB lower than the limit line was not reported.

Please refer to Appendix B.



4.4 Radiated Spurious Emission

4.4.1 Description of Radiated Spurious Emission Measurement

The radiated spurious emission was measured by substitution method according to ANSI C63.26-2015. The power of any emission outside of the authorized operating frequency ranges must be attenuated below the transmitter power (P) by a factor of at least -40dBm / MHz. The spectrum is scanned from 30 MHz up to a frequency including its 10th harmonic.

4.4.2 Test Procedures

1. The EUT was placed on a turntable with 0.8 meter height for frequency below 1GHz and 1.5 meter height for frequency above 1GHz respectively above ground.
2. The EUT was set 3 meters from the receiving antenna mounted on the antenna tower.
3. The table was rotated 360 degrees to determine the position of the highest spurious emission.
4. The height of the receiving antenna is varied between 1m to 4m to search the maximum spurious emission for both horizontal and vertical polarizations.
5. During the measurement, the system simulator parameters were set to force the EUT transmitting at maximum output power.
6. Make the measurement with the spectrum analyzer's RBW = 1MHz, VBW = 3MHz, taking the record of maximum spurious emission.
7. A horn antenna was substituted in place of the EUT and was driven by a signal generator. Tune the output power of signal generator to the same emission level with EUT maximum spurious emission.
$$\text{EIRP (dBm)} = \text{S.G. Power} - \text{Tx Cable Loss} + \text{Tx Antenna Gain}$$
$$\text{ERP (dBm)} = \text{EIRP} - 2.15$$
8. The RF fundamental frequency should be excluded against the limit line in the operating frequency band.
The limit line is -40dBm/MHz



5 List of Measuring Equipment

Instrument	Manufacturer	Model No.	Serial No.	Characteristics	Calibration Date	Test Date	Due Date	Remark
Spectrum Analyzer	R&S	FSV40	101078	10Hz~40GHz	Apr. 07, 2022	Mar. 22, 2023~Apr. 16, 2023	Apr. 06, 2024	Conducted (TH01-SZ)
DC Power Supply	TTI	PL330P	290070	Max 32V , 3A	Oct. 17, 2022	Mar. 22, 2023~Apr. 16, 2023	Oct. 16, 2023	Conducted (TH01-SZ)
Power Divider	TOJOIN	PS-2SM-04265	60.06.020.0077	0.4GHz~26.5GHz	Dec. 25, 2022	Mar. 22, 2023~Apr. 16, 2023	Dec. 24, 2023	Conducted (TH01-SZ)
Thermal Chamber	Ten Billion Hongzhangroup	LP-150U	H2014081803	-40~+150°C	Jul. 07, 2022	Mar. 22, 2023~Apr. 16, 2023	Jul. 06, 2023	Conducted (TH01-SZ)
Spectrum Analyzer	R&S	FSV40	101040	10Hz~40GHz	Oct. 12, 2022	Mar. 22, 2023~Apr. 16, 2023	Oct. 11, 2023	Conducted (TH01-KS)
Power divider	STI	STI08-0055	-	0.5~40GHz	/	Mar. 22, 2023~Apr. 16, 2023	/	Conducted (TH01-KS)
Temperature & humidity chamber	Hongzhan	LP-150U	H2014011440	-40~+150°C 20%~95%RH	Jul. 15, 2022	Mar. 22, 2023~Apr. 16, 2023	Jul. 14, 2023	Conducted (TH01-KS)
EXA Spectrum Analyzer	Keysight	N9010A	MY55150244	10Hz-44G,MAX 30dB	Mar. 24, 2022	Mar. 16, 2023	Mar. 23, 2023	Radiation (03CH05-KS)
Loop Antenna	R&S	HFH2-Z2	100321	9kHz~30MHz	Oct. 29, 2022	Mar. 16, 2023	Oct. 28, 2023	Radiation (03CH05-KS)
Bilog Antenna	TeseQ	CBL6111D	49922	30MHz-1GHz	May 24 ,2022	Mar. 16, 2023	May 23, 2023	Radiation (03CH05-KS)
Double Ridge Horn Antenna	ETS-Lindgren	3117	00218642	1GHz~18GHz	Apr. 18, 2022	Mar. 16, 2023	Apr. 17, 2023	Radiation (03CH05-KS)
SHF-EHF Horn	Com-power	AH-840	101093	18GHz~40GHz	Jan. 08, 2023	Mar. 16, 2023	Jan. 07, 2024	Radiation (03CH05-KS)
Amplifier	SONOMA	310N	380826	9KHz-1GHz	Jul. 11, 2022	Mar. 16, 2023	Jul. 10, 2023	Radiation (03CH05-KS)
Amplifier	EM	EM18G40G A	060852	18~40GHz	Jan. 05, 2023	Mar. 16, 2023	Jan. 04, 2024	Radiation (03CH05-KS)
high gain Amplifier	EM	EM01G18G A	060839	1Ghz-18Ghz	Oct. 12, 2022	Mar. 16, 2023	Oct. 11, 2023	Radiation (03CH05-KS)
Amplifier	EM	EM01G18G A	060833	1Ghz-18Ghz	Jan. 05, 2023	Mar. 16, 2023	Jan. 04, 2024	Radiation (03CH05-KS)
AC Power Source	Chroma	61601	F104090004	N/A	NCR	Mar. 16, 2023	NCR	Radiation (03CH05-KS)
Turn Table	ChamPro	EM 1000-T	060762-T	0~360 degree	NCR	Mar. 16, 2023	NCR	Radiation (03CH05-KS)
Antenna Mast	ChamPro	EM 1000-A	060762-A	1 m~4 m	NCR	Mar. 16, 2023	NCR	Radiation (03CH05-KS)

NCR: No Calibration Required

6 Uncertainty of Evaluation

Uncertainty of Conducted Measurement

<TH01-SZ>

Test Item	Uncertainty
Conducted Power	±1.34 dB
Conducted Emissions	±1.34 dB
Occupied Channel Bandwidth	±0.13 %

<TH01-KS>

Test Item	Uncertainty
Conducted Power	±0.46 dB
Conducted Emissions	±0.48 dB
Occupied Channel Bandwidth	±0.1 %

Uncertainty of Radiated Emission Measurement (30 MHz ~ 1000 MHz)

Measuring Uncertainty for a Level of Confidence of 95% (U = 2Uc(y))	2.5dB
---	-------

Uncertainty of Radiated Emission Measurement (1 GHz ~ 18 GHz)

Measuring Uncertainty for a Level of Confidence of 95% (U = 2Uc(y))	2.1dB
---	-------

Uncertainty of Radiated Emission Measurement (18 GHz ~ 40 GHz)

Measuring Uncertainty for a Level of Confidence of 95% (U = 2Uc(y))	2.1dB
---	-------

----- THE END -----



Appendix A. Test Results of Conducted Test

Conducted Output Power(Average power) and EIRP

LTE Band 48_Ant.4:

BW [MHz]	Modulation	RB Size	RB Offset	Power Low Ch. / Freq.	Power Middle Ch. / Freq.	Power High Ch. / Freq.	EIRP(W)		
Channel				55340	55990	56640			
Frequency (MHz)				3560	3625	3690	L	M	H
20	QPSK	1	0	23.12	23.24	23.09	0.0649	0.0667	0.0644
20	QPSK	1	99	23.00	23.07	23.03	0.0631	0.0641	0.0635
20	QPSK	100	0	22.18	22.28	22.19	0.0522	0.0535	0.0524
20	16QAM	1	0	22.34	22.39	22.36	0.0542	0.0548	0.0545
20	64QAM	1	0	21.17	21.23	21.15	0.0414	0.0420	0.0412
20	256QAM	1	0	17.85	18.13	18.01	0.0193	0.0206	0.0200
Channel				55315	55990	56665	EIRP(W)		
Frequency (MHz)				3557.5	3625	3692.5	L	M	H
15	QPSK	1	0	23.01	23.16	23.04	0.0632	0.0655	0.0637
15	16QAM	1	0	22.24	22.29	22.18	0.0530	0.0536	0.0522
Channel				55290	55990	56690	EIRP(W)		
Frequency (MHz)				3555	3625	3695	L	M	H
10	QPSK	1	0	23.07	23.11	23.03	0.0641	0.0647	0.0635
10	16QAM	1	0	22.22	22.36	22.26	0.0527	0.0545	0.0532
Channel				55265	55990	56715	EIRP(W)		
Frequency (MHz)				3552.5	3625	3697.5	L	M	H
5	QPSK	1	0	23.08	23.17	23.02	0.0643	0.0656	0.0634
5	16QAM	1	0	22.16	22.29	22.22	0.0520	0.0536	0.0527

CA_48B_Ant.4:

	Modulation	PCC		SCC		Power Low Ch. / Freq. (dBm)	Power Middle Ch. / Freq. (dBm)	Power High Ch. / Freq. (dBm)	EIRP (W)		
		RB Size	RB Offset	RB Size	RB Offset				L	M	H
		channel									
10M+10M	QPSK	1	0	1	49	14.01	14.35	14.32	0.0080	0.0086	0.0086
	QPSK	1	49	1	0	22.19	22.69	22.53	0.0524	0.0587	0.0566
	QPSK	50	0	50	0	20.69	21.14	21.05	0.0371	0.0411	0.0403
	16QAM	1	0	1	49	13.69	14.31	14.41	0.0074	0.0085	0.0087
	16QAM	1	49	1	0	21.13	21.7	21.64	0.0410	0.0468	0.0461
	16QAM	50	0	50	0	19.71	20.2	20.07	0.0296	0.0331	0.0321
	64QAM	1	0	1	49	13.66	14.08	14	0.0073	0.0081	0.0079
	64QAM	1	49	1	0	18.9	19.39	19.27	0.0245	0.0275	0.0267
	64QAM	50	0	50	0	19.81	20.26	20.12	0.0303	0.0336	0.0325
	256QAM	1	0	1	49	13.86	14.25	14.2	0.0077	0.0084	0.0083
	256QAM	1	49	1	0	17.04	17.54	17.41	0.0160	0.0179	0.0174
	256QAM	50	0	50	0	17.96	18.42	18.3	0.0198	0.0220	0.0214



CA_48C_Ant.2:

BW [MHz]	Modulation	RB Size	RB Offset	Power Low	Power Middle	Power High	EIRP (W)		
				Ch. / Freq. (dBm)	Ch. / Freq. (dBm)	Ch. / Freq. (dBm)	L	M	H
Channel				L	M	H	L	M	H
20+20	QPSK	1RB01RBMAX		10.40	14.02	9.45	0.0031	0.0071	0.0025
	QPSK	1RBMAX1RB0		22.59	22.30	21.55	0.0512	0.0479	0.0403
	QPSK	FULL		20.84	20.71	20.05	0.0342	0.0332	0.0285
	16QAM	1RB01RBMAX		10.48	14.00	9.54	0.0031	0.0071	0.0025
	16QAM	1RBMAX1RB0		21.62	21.42	20.74	0.0409	0.0391	0.0334
	16QAM	FULL		19.82	19.70	19.07	0.0270	0.0263	0.0228
	64QAM	1RB01RBMAX		10.24	13.70	9.26	0.0030	0.0066	0.0024
	64QAM	1RBMAX1RB0		19.24	19.05	18.26	0.0237	0.0226	0.0189
	64QAM	FULL		19.92	19.76	18.91	0.0277	0.0267	0.0219
	256QAM	1RB01RBMAX		10.34	13.93	9.58	0.0030	0.0070	0.0026
	256QAM	1RBMAX1RB0		17.52	17.35	16.57	0.0159	0.0153	0.0128
	256QAM	FULL		17.92	17.95	17.10	0.0175	0.0176	0.0145
20+15	QPSK	1RB01RBMAX		10.34	14.04	9.41	0.0030	0.0071	0.0025
	QPSK	1RBMAX1RB0		22.54	22.37	21.51	0.0506	0.0486	0.0399
	QPSK	FULL		20.94	20.75	20.04	0.0350	0.0335	0.0284
	16QAM	1RB01RBMAX		10.38	14.10	9.37	0.0031	0.0072	0.0024
	16QAM	1RBMAX1RB0		21.64	21.58	20.83	0.0411	0.0406	0.0341
	16QAM	FULL		20.00	19.75	19.08	0.0282	0.0266	0.0228
	64QAM	1RB01RBMAX		10.11	13.78	9.08	0.0029	0.0067	0.0023
	64QAM	1RBMAX1RB0		19.27	19.16	18.35	0.0238	0.0232	0.0193
	64QAM	FULL		20.04	19.78	19.08	0.0284	0.0268	0.0228
	256QAM	1RB01RBMAX		10.34	13.93	9.44	0.0030	0.0070	0.0025
	256QAM	1RBMAX1RB0		17.52	17.36	16.64	0.0159	0.0153	0.0130
	256QAM	FULL		18.02	17.84	17.13	0.0179	0.0171	0.0146
20+10	QPSK	1RB01RBMAX		10.02	13.83	9.10	0.0028	0.0068	0.0023
	QPSK	1RBMAX1RB0		22.43	22.24	21.37	0.0493	0.0472	0.0386
	QPSK	FULL		20.86	20.48	20.24	0.0344	0.0315	0.0298
	16QAM	1RB01RBMAX		10.07	13.98	9.19	0.0029	0.0070	0.0023
	16QAM	1RBMAX1RB0		21.59	21.36	20.57	0.0406	0.0385	0.0321
	16QAM	FULL		19.92	19.67	18.96	0.0277	0.0261	0.0222
	64QAM	1RB01RBMAX		9.73	13.52	9.05	0.0026	0.0063	0.0023
	64QAM	1RBMAX1RB0		19.25	18.95	18.16	0.0237	0.0221	0.0185
	64QAM	FULL		20.05	19.71	18.99	0.0285	0.0264	0.0223
	256QAM	1RB01RBMAX		9.98	13.80	9.19	0.0028	0.0068	0.0023
	256QAM	1RBMAX1RB0		17.49	17.11	16.28	0.0158	0.0145	0.0120
	256QAM	FULL		17.71	17.80	16.97	0.0166	0.0170	0.0140
20+5	QPSK	1RB01RBMAX		10.65	13.93	10.18	0.0033	0.0070	0.0029
	QPSK	1RBMAX1RB0		22.63	22.28	21.57	0.0516	0.0476	0.0405
	QPSK	FULL		20.92	20.74	20.01	0.0348	0.0334	0.0282
	16QAM	1RB01RBMAX		10.61	14.09	10.11	0.0032	0.0072	0.0029
	16QAM	1RBMAX1RB0		21.60	21.47	20.67	0.0407	0.0395	0.0329
	16QAM	FULL		19.94	19.83	19.18	0.0278	0.0271	0.0233
	64QAM	1RB01RBMAX		10.66	13.75	10.13	0.0033	0.0067	0.0029
	64QAM	1RBMAX1RB0		19.30	19.12	18.31	0.0240	0.0230	0.0191
64QAM	FULL		20.01	19.58	19.06	0.0282	0.0256	0.0227	



	256QAM	1RB01RBMAX	10.57	13.71	10.03	0.0032	0.0066	0.0028
	256QAM	1RBMAX1RB0	17.68	17.43	16.35	0.0165	0.0156	0.0122
	256QAM	FULL	18.01	17.51	17.00	0.0178	0.0159	0.0141
15+20	QPSK	1RB01RBMAX	10.31	13.94	9.50	0.0030	0.0070	0.0025
	QPSK	1RBMAX1RB0	22.54	22.46	21.69	0.0506	0.0497	0.0416
	QPSK	FULL	20.83	20.92	20.10	0.0341	0.0348	0.0288
	16QAM	1RB01RBMAX	10.26	13.96	9.56	0.0030	0.0070	0.0025
	16QAM	1RBMAX1RB0	21.72	21.57	20.88	0.0419	0.0405	0.0345
	16QAM	FULL	20.11	19.84	19.07	0.0289	0.0272	0.0228
	64QAM	1RB01RBMAX	10.18	13.68	9.24	0.0029	0.0066	0.0024
	64QAM	1RBMAX1RB0	19.38	19.11	18.49	0.0244	0.0230	0.0199
	64QAM	FULL	19.93	19.80	19.17	0.0277	0.0269	0.0233
	256QAM	1RB01RBMAX	10.01	13.95	9.21	0.0028	0.0070	0.0023
	256QAM	1RBMAX1RB0	17.43	17.34	16.69	0.0156	0.0153	0.0132
	256QAM	FULL	17.99	17.82	17.23	0.0177	0.0171	0.0149
10+20	QPSK	1RB01RBMAX	10.20	13.87	9.33	0.0030	0.0069	0.0024
	QPSK	1RBMAX1RB0	22.44	22.38	21.61	0.0494	0.0488	0.0408
	QPSK	FULL	20.90	20.69	20.11	0.0347	0.0330	0.0289
	16QAM	1RB01RBMAX	9.99	13.89	9.26	0.0028	0.0069	0.0024
	16QAM	1RBMAX1RB0	21.72	21.40	20.80	0.0419	0.0389	0.0339
	16QAM	FULL	19.93	19.82	19.28	0.0277	0.0270	0.0239
	64QAM	1RB01RBMAX	9.92	13.55	9.22	0.0028	0.0064	0.0024
	64QAM	1RBMAX1RB0	19.38	19.00	18.37	0.0244	0.0224	0.0194
	64QAM	FULL	19.92	19.79	19.09	0.0277	0.0269	0.0229
	256QAM	1RB01RBMAX	9.90	13.73	9.21	0.0028	0.0067	0.0023
	256QAM	1RBMAX1RB0	17.42	17.25	16.57	0.0156	0.0150	0.0128
	256QAM	FULL	17.97	17.87	17.20	0.0177	0.0173	0.0148
5+20	QPSK	1RB01RBMAX	10.62	14.02	9.79	0.0033	0.0071	0.0027
	QPSK	1RBMAX1RB0	22.46	22.41	21.92	0.0497	0.0491	0.0439
	QPSK	FULL	20.76	20.82	20.05	0.0336	0.0340	0.0285
	16QAM	1RB01RBMAX	10.81	14.05	10.27	0.0034	0.0072	0.0030
	16QAM	1RBMAX1RB0	21.55	21.57	21.05	0.0403	0.0405	0.0359
	16QAM	FULL	19.93	19.80	19.21	0.0277	0.0269	0.0235
	64QAM	1RB01RBMAX	10.43	13.85	10.05	0.0031	0.0068	0.0029
	64QAM	1RBMAX1RB0	19.48	19.31	18.65	0.0250	0.0240	0.0207
	64QAM	FULL	19.94	19.82	19.20	0.0278	0.0270	0.0234
	256QAM	1RB01RBMAX	10.73	13.91	10.01	0.0033	0.0069	0.0028
	256QAM	1RBMAX1RB0	17.54	17.56	16.72	0.0160	0.0161	0.0132
	256QAM	FULL	17.91	17.92	17.25	0.0174	0.0175	0.0150



LTE Band 48

26dB Bandwidth

Mode	LTE Band 48 : 26dB BW(MHz)											
BW	1.4MHz		3MHz		5MHz		10MHz		15MHz		20MHz	
Mod.	QPSK	16QAM	QPSK	16QAM	QPSK	16QAM	QPSK	16QAM	QPSK	16QAM	QPSK	16QAM
Lowest CH	-	-	-	-	4.87	4.73	10.41	9.83	16.15	14.24	18.98	18.74
Middle CH	-	-	-	-	4.79	4.87	9.75	9.79	14.33	14.15	18.94	18.82
Highest CH	-	-	-	-	4.82	4.85	9.61	9.63	14.36	14.30	18.78	18.86
Mode	LTE Band 48 : 26dB BW(MHz)											
BW	1.4MHz		3MHz		5MHz		10MHz		15MHz		20MHz	
Mod.	64QAM		64QAM		64QAM		64QAM		64QAM		64QAM	
Lowest CH	-	-	-	-	4.79	-	9.61	-	14.21	-	18.62	-
Middle CH	-	-	-	-	4.82	-	9.69	-	14.90	-	18.66	-
Highest CH	-	-	-	-	4.73	-	9.81	-	14.48	-	18.86	-



LTE Band 48

Lowest Channel / 5MHz / QPSK

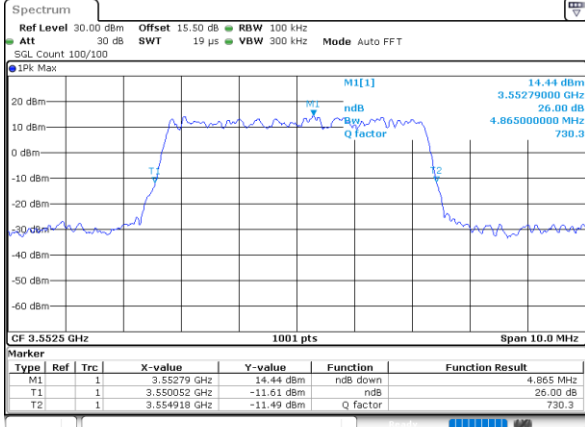

Date: 28.MAR.2023 22:30:16

Lowest Channel / 5MHz / 16QAM

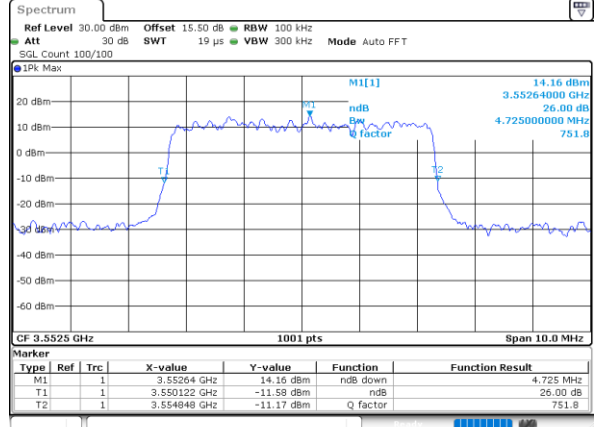

Date: 28.MAR.2023 22:30:40

Middle Channel / 5MHz / QPSK

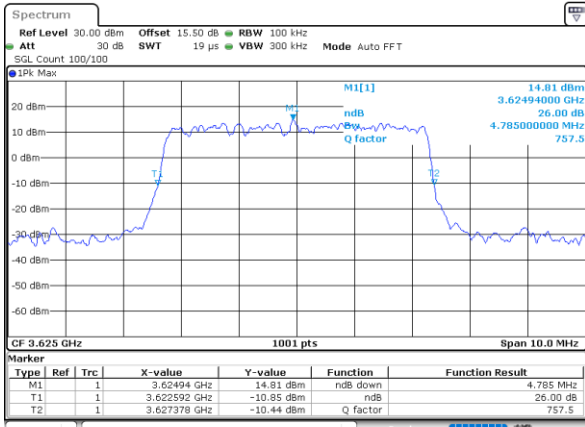

Date: 28.MAR.2023 22:31:51

Middle Channel / 5MHz / 16QAM

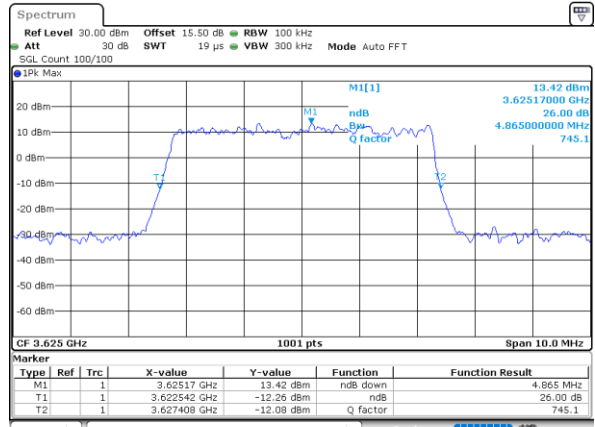

Date: 28.MAR.2023 22:32:15

Highest Channel / 5MHz / QPSK

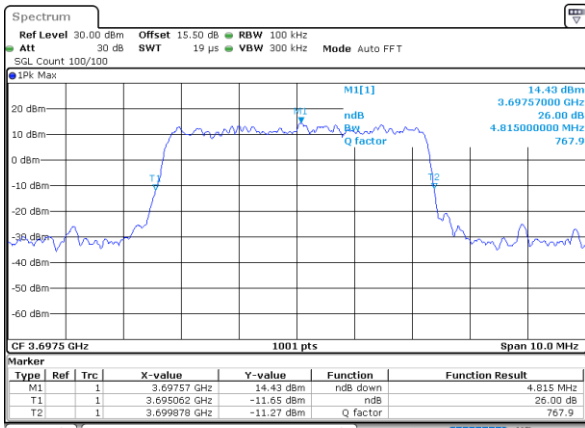

Date: 28.MAR.2023 22:33:27

Highest Channel / 5MHz / 16QAM

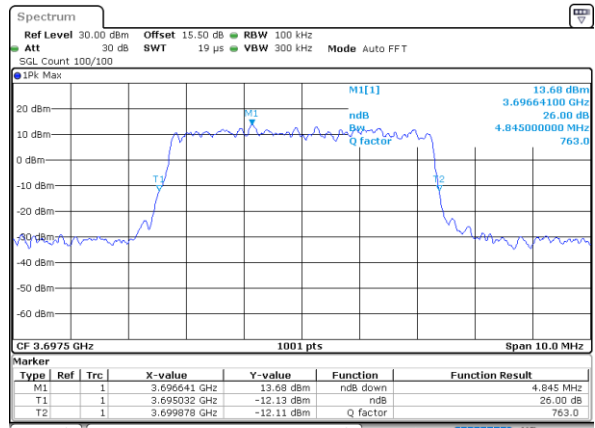

Date: 28.MAR.2023 22:33:51



LTE Band 48

Lowest Channel / 10MHz / QPSK

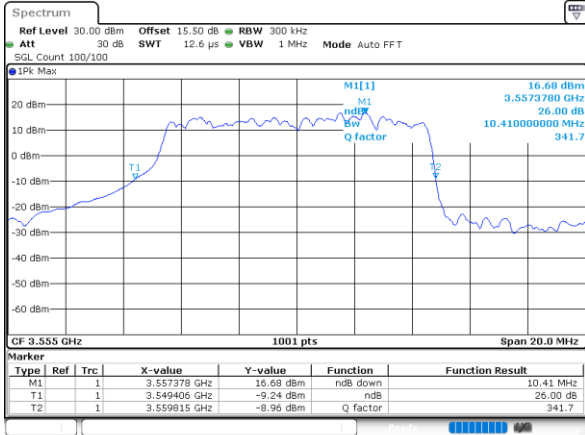

Date: 28.MAR.2023 22:35:04

Lowest Channel / 10MHz / 16QAM

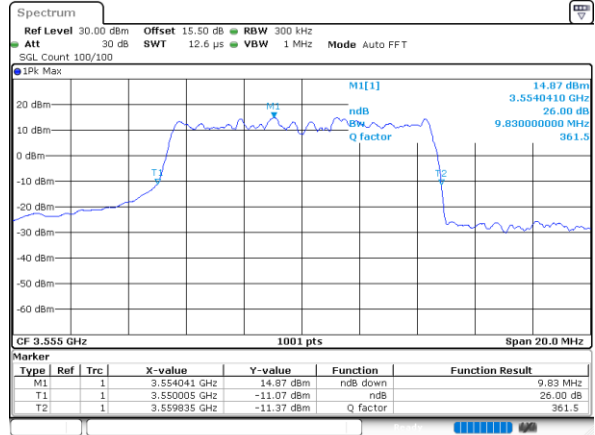

Date: 28.MAR.2023 22:35:28

Middle Channel / 10MHz / QPSK

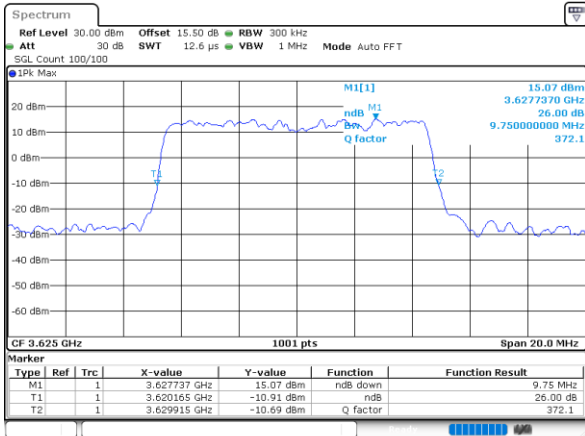

Date: 28.MAR.2023 22:36:39

Middle Channel / 10MHz / 16QAM

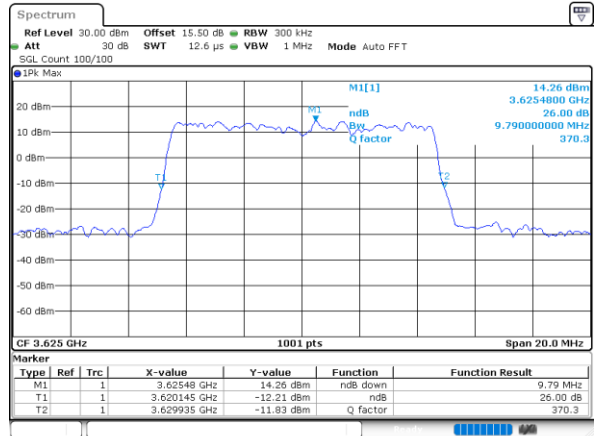

Date: 28.MAR.2023 22:37:03

Highest Channel / 10MHz / QPSK

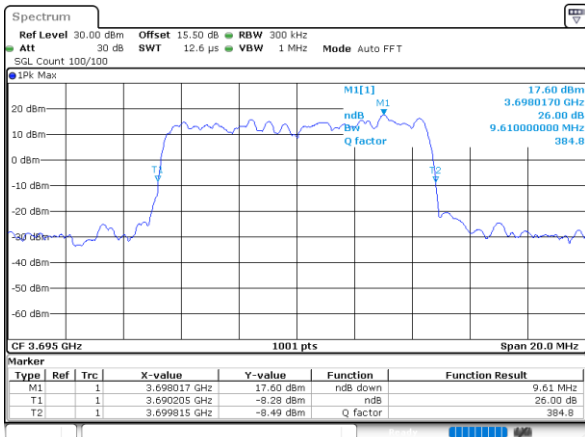

Date: 28.MAR.2023 22:38:15

Highest Channel / 10MHz / 16QAM

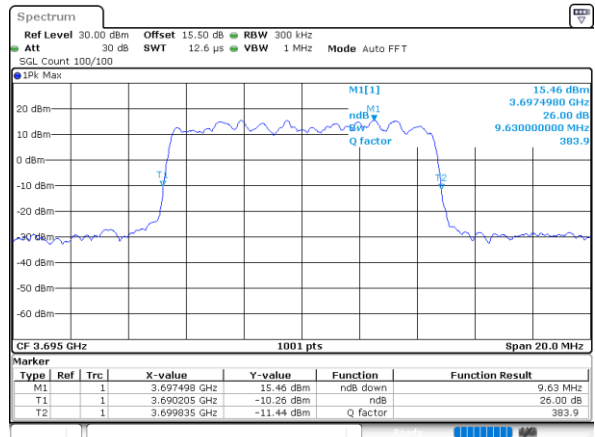

Date: 28.MAR.2023 22:38:39



LTE Band 48

Lowest Channel / 15MHz / QPSK

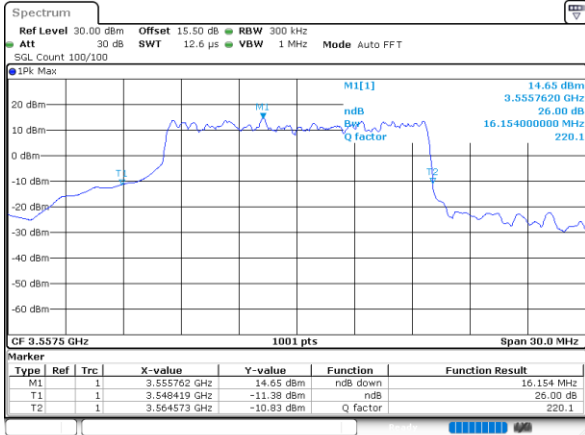

Date: 28.MAR.2023 22:39:52

Lowest Channel / 15MHz / 16QAM

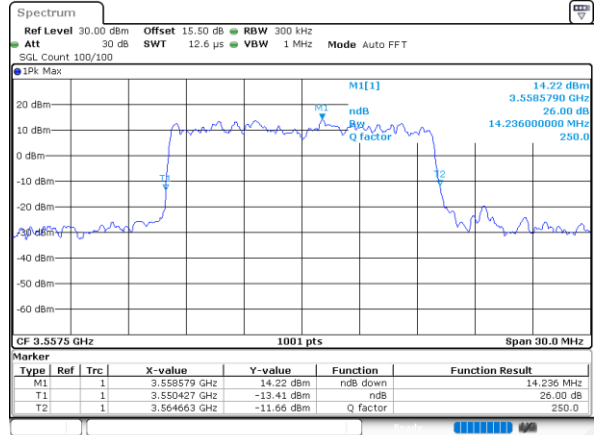

Date: 28.MAR.2023 22:40:16

Middle Channel / 15MHz / QPSK

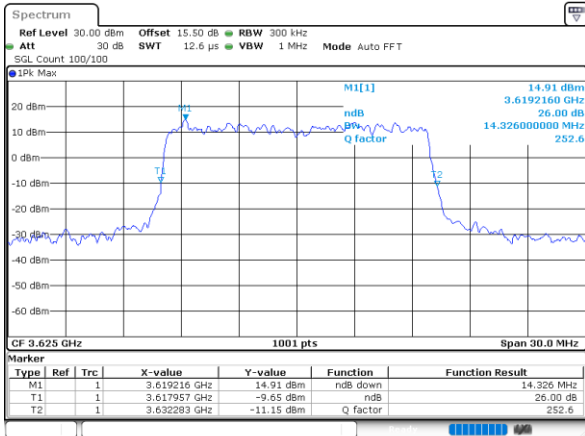

Date: 28.MAR.2023 22:41:26

Middle Channel / 15MHz / 16QAM

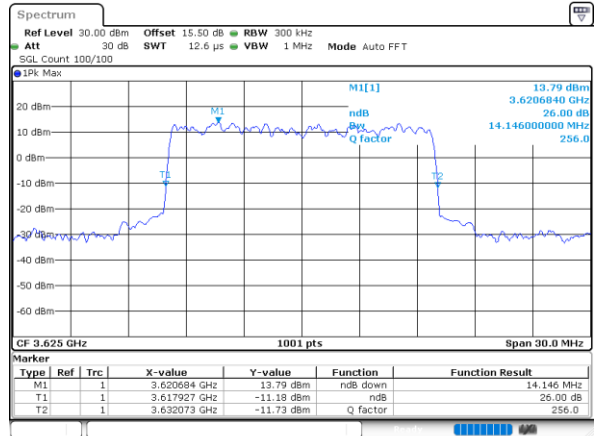

Date: 28.MAR.2023 22:41:50

Highest Channel / 15MHz / QPSK

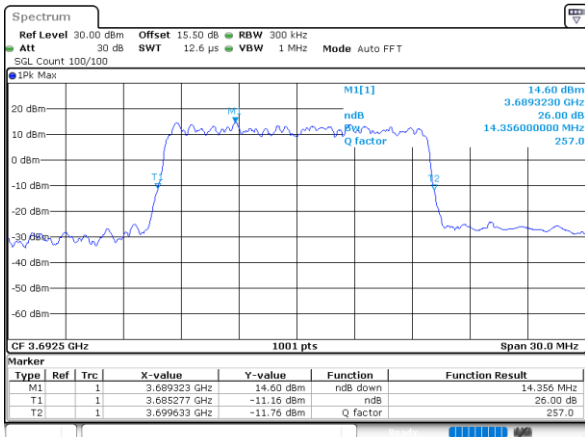

Date: 28.MAR.2023 22:43:02

Highest Channel / 15MHz / 16QAM

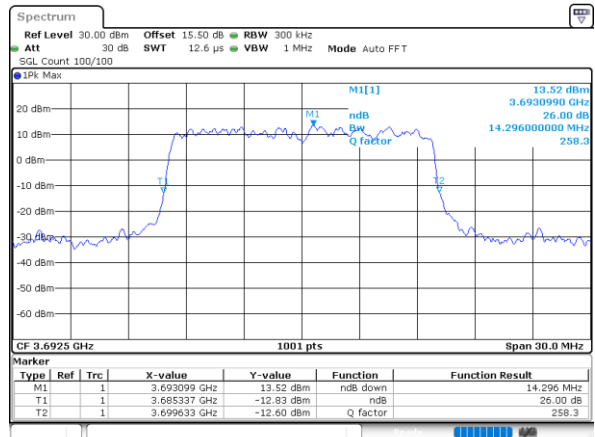

Date: 28.MAR.2023 22:43:26



LTE Band 48

Lowest Channel / 20MHz / QPSK

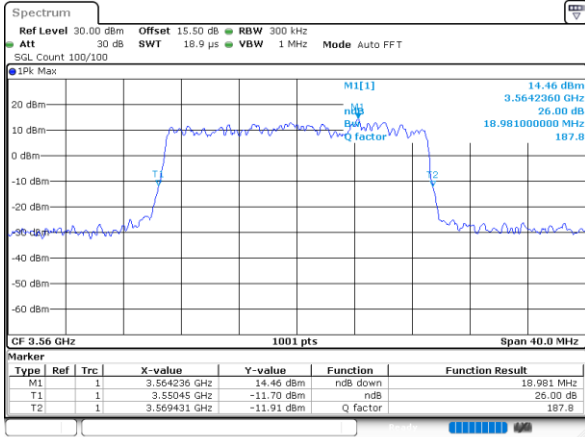

Date: 28.MAR.2023 22:44:39

Lowest Channel / 20MHz / 16QAM

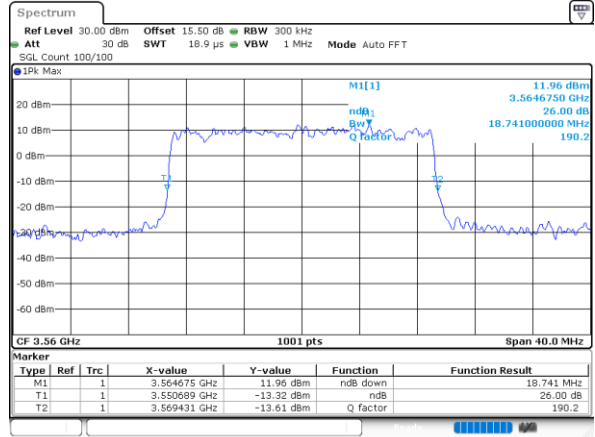

Date: 28.MAR.2023 22:45:03

Middle Channel / 20MHz / QPSK

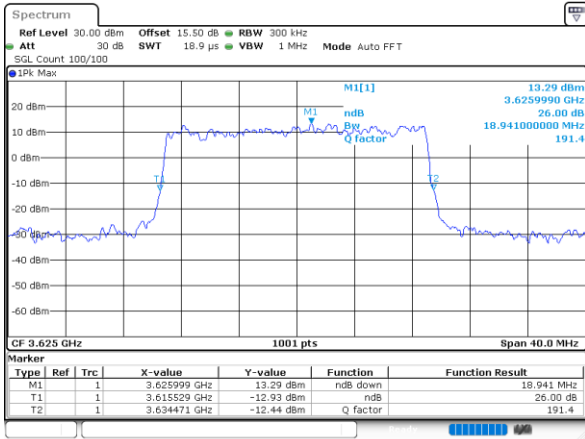

Date: 28.MAR.2023 22:46:14

Middle Channel / 20MHz / 16QAM

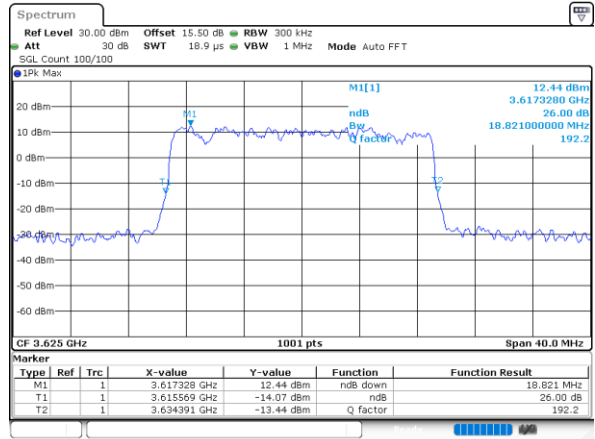

Date: 28.MAR.2023 22:46:38

Highest Channel / 20MHz / QPSK

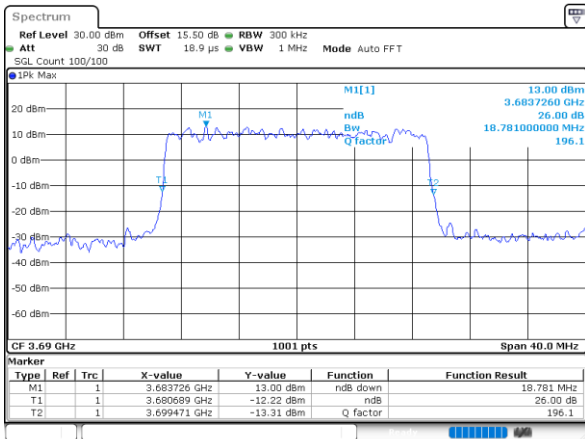

Date: 28.MAR.2023 22:47:49

Highest Channel / 20MHz / 16QAM

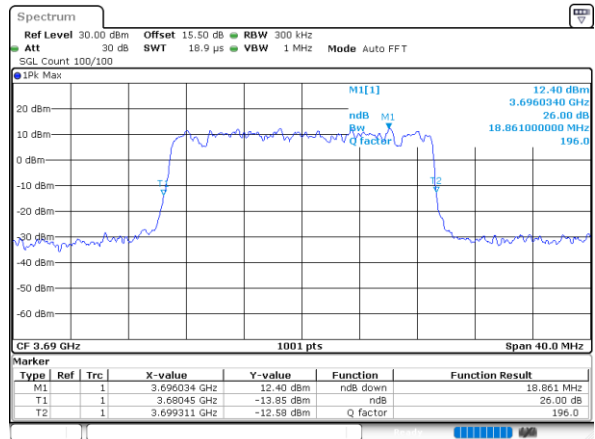

Date: 28.MAR.2023 22:48:13



LTE Band 48

Lowest Channel / 5MHz / 64QAM

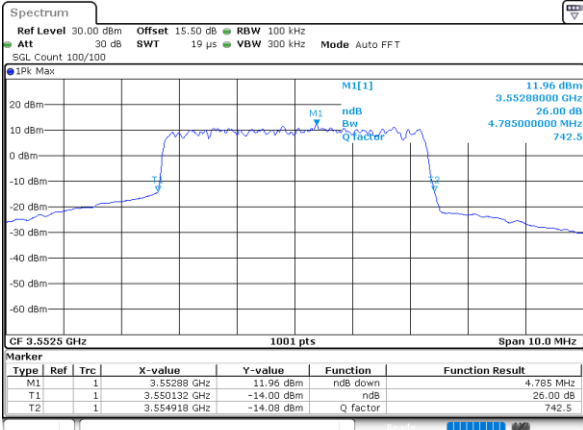

Date: 28.MAR.2023 22:48:53

Lowest Channel / 10MHz / 64QAM

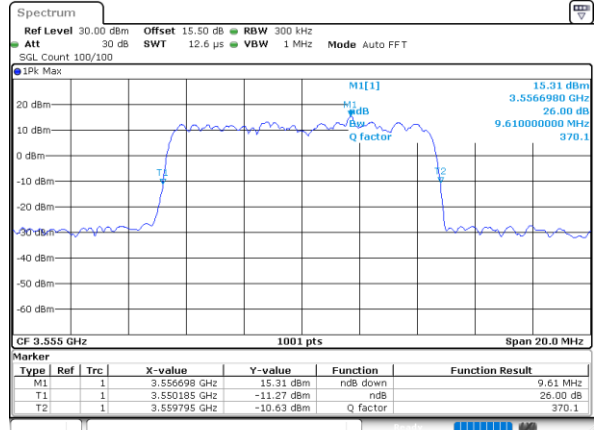

Date: 28.MAR.2023 22:50:50

Middle Channel / 5MHz / 64QAM

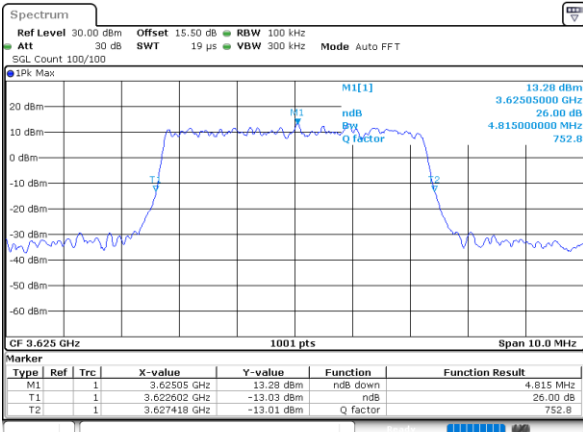

Date: 28.MAR.2023 22:49:32

Middle Channel / 10MHz / 64QAM

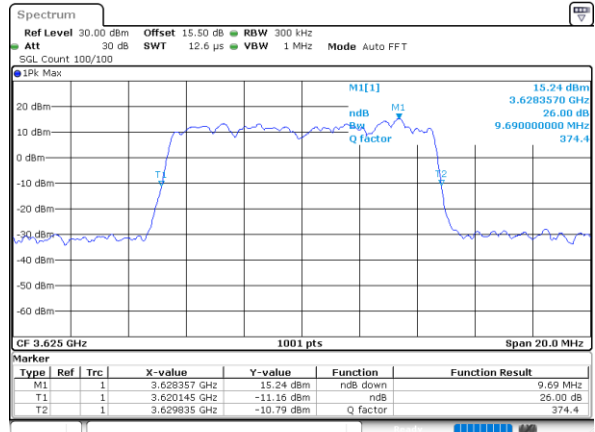

Date: 28.MAR.2023 22:51:28

Highest Channel / 5MHz / 64QAM

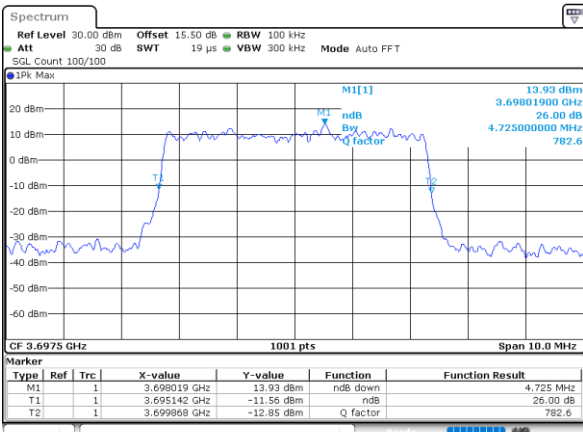

Date: 28.MAR.2023 22:50:10

Highest Channel / 10MHz / 64QAM

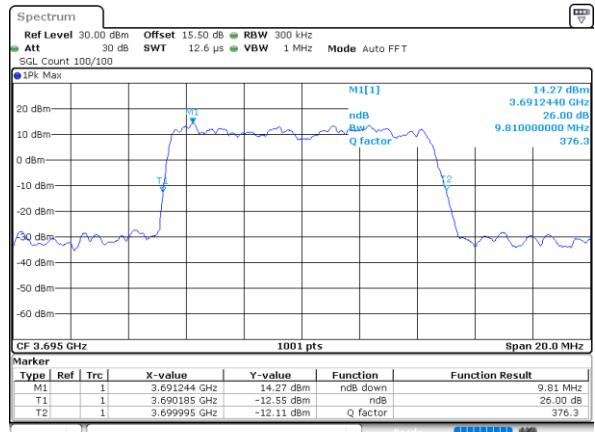

Date: 28.MAR.2023 22:52:07



LTE Band 48

Lowest Channel / 15MHz / 64QAM

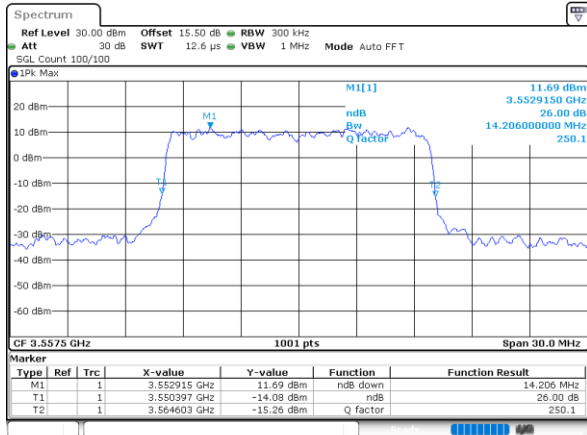

Date: 28.MAR.2023 22:52:47

Lowest Channel / 20MHz / 64QAM

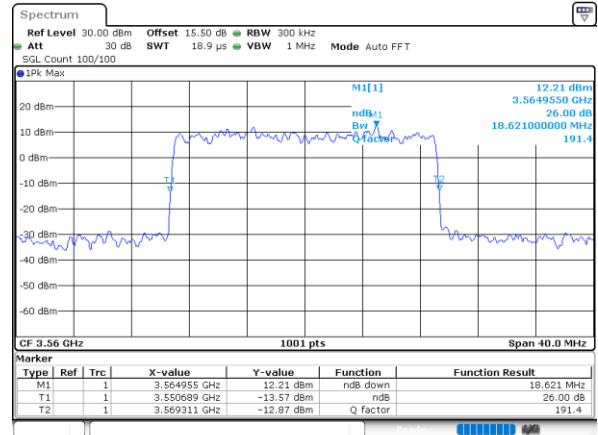

Date: 28.MAR.2023 22:54:44

Middle Channel / 15MHz / 64QAM

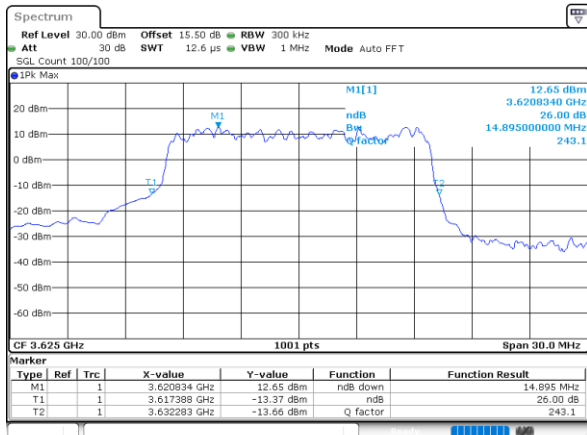

Date: 28.MAR.2023 22:53:26

Middle Channel / 20MHz / 64QAM

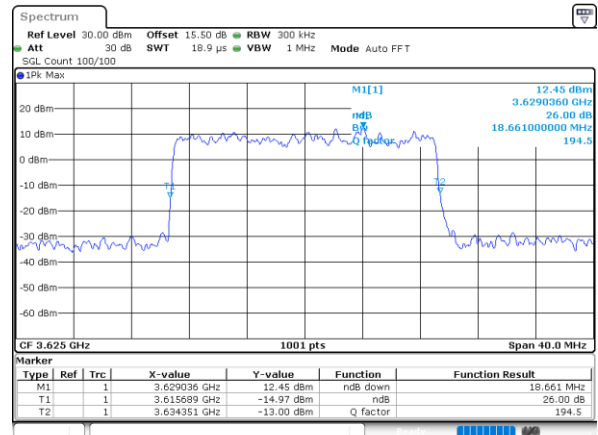

Date: 28.MAR.2023 22:55:23

Highest Channel / 15MHz / 64QAM

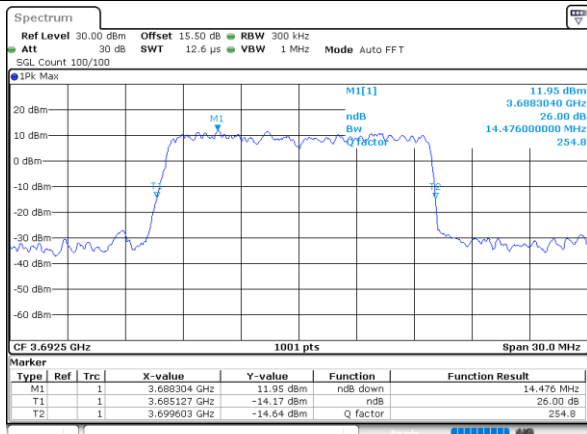

Date: 28.MAR.2023 22:54:04

Highest Channel / 20MHz / 64QAM

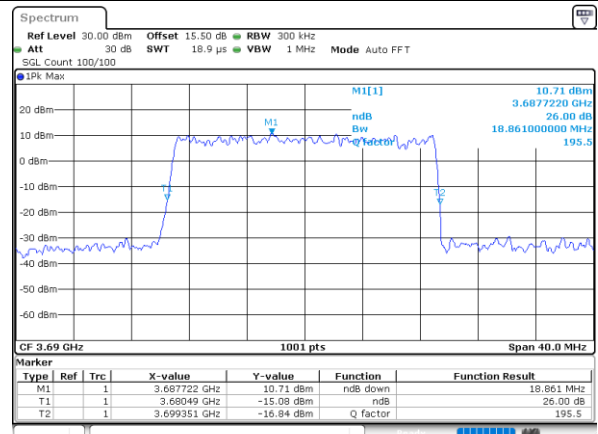

Date: 28.MAR.2023 22:56:01



Occupied Bandwidth

Mode	LTE Band 48 : 99%OBW(MHz)											
BW	1.4MHz		3MHz		5MHz		10MHz		15MHz		20MHz	
Mod.	QPSK	16QAM	QPSK	16QAM	QPSK	16QAM	QPSK	16QAM	QPSK	16QAM	QPSK	16QAM
Lowest CH	-	-	-	-	4.49	4.48	9.03	8.97	13.43	13.46	17.86	17.94
Middle CH	-	-	-	-	4.48	4.47	8.99	8.99	13.43	13.46	17.90	17.86
Highest CH	-	-	-	-	4.49	4.50	9.03	9.03	13.43	13.46	17.86	17.90
Mode	LTE Band 48 : 99%OBW(MHz)											
BW	1.4MHz		3MHz		5MHz		10MHz		15MHz		20MHz	
Mod.	64QAM		64QAM		64QAM		64QAM		64QAM		64QAM	
Lowest CH	-	-	-	-	4.52	-	9.11	-	13.46	-	17.90	-
Middle CH	-	-	-	-	4.48	-	8.97	-	13.40	-	17.90	-
Highest CH	-	-	-	-	4.53	-	9.01	-	13.46	-	17.86	-



LTE Band 48

Lowest Channel / 5MHz / QPSK

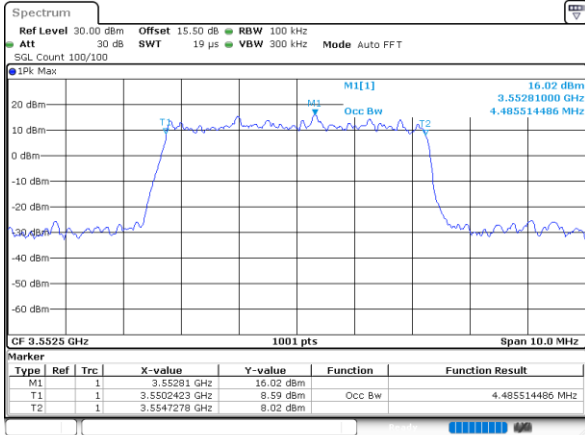

Date: 28_MAR_2023 22:29:20

Lowest Channel / 5MHz / 16QAM

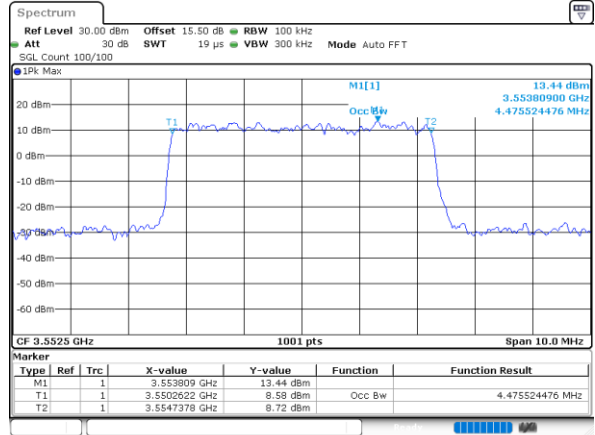

Date: 28_MAR_2023 22:29:52

Middle Channel / 5MHz / QPSK

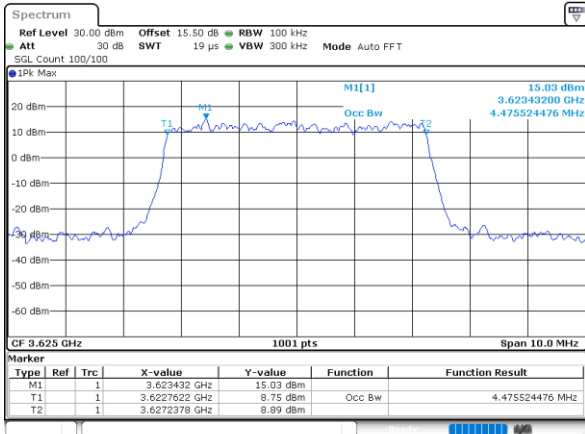

Date: 28_MAR_2023 22:31:04

Middle Channel / 5MHz / 16QAM

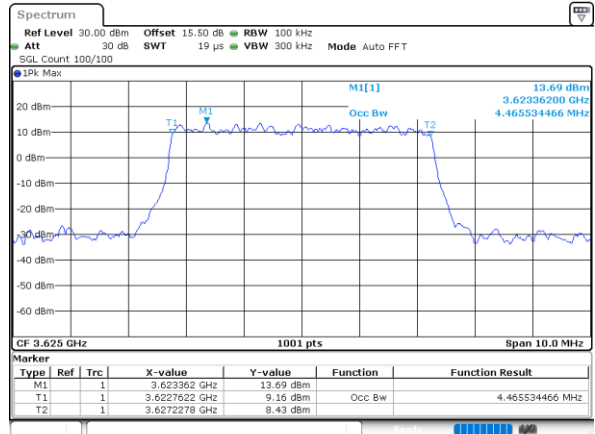

Date: 28_MAR_2023 22:31:28

Highest Channel / 5MHz / QPSK

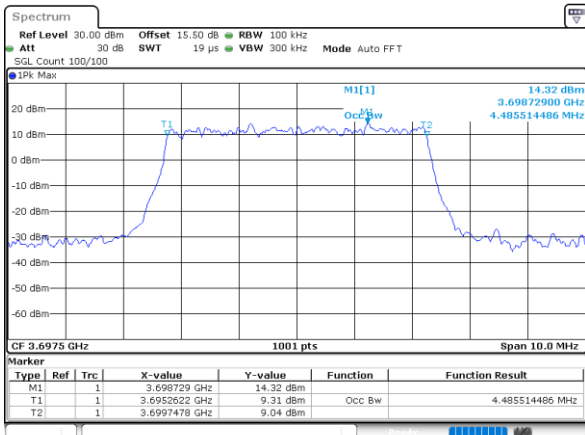

Date: 28_MAR_2023 22:32:39

Highest Channel / 5MHz / 16QAM

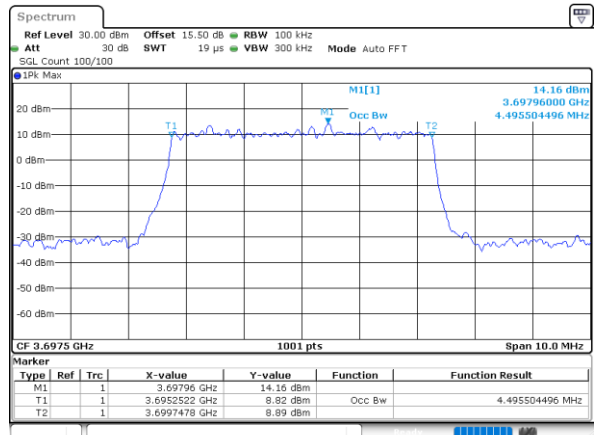

Date: 28_MAR_2023 22:33:03



LTE Band 48

Lowest Channel / 10MHz / QPSK

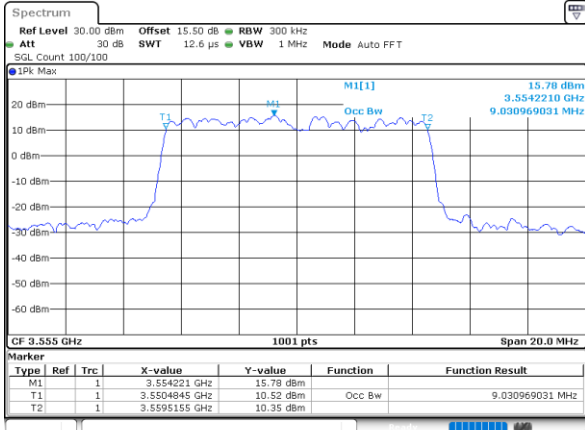

Date: 28.MAR.2023 22:34:16

Lowest Channel / 10MHz / 16QAM

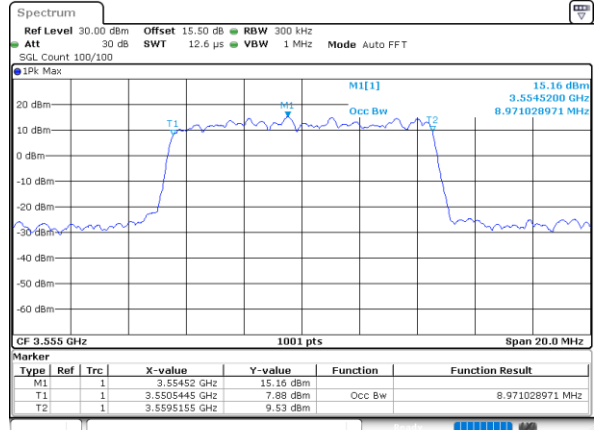

Date: 28.MAR.2023 22:34:40

Middle Channel / 10MHz / QPSK

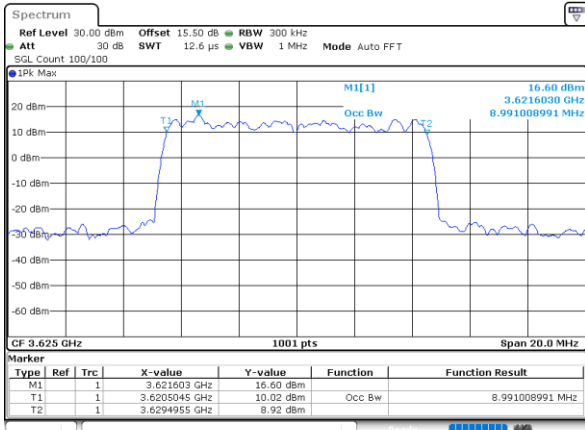

Date: 28.MAR.2023 22:35:52

Middle Channel / 10MHz / 16QAM

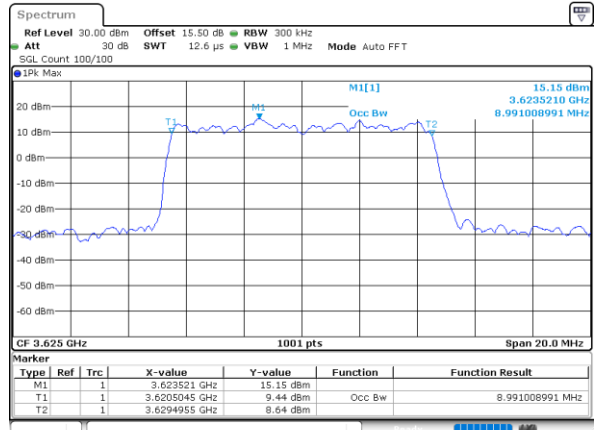

Date: 28.MAR.2023 22:36:16

Highest Channel / 10MHz / QPSK

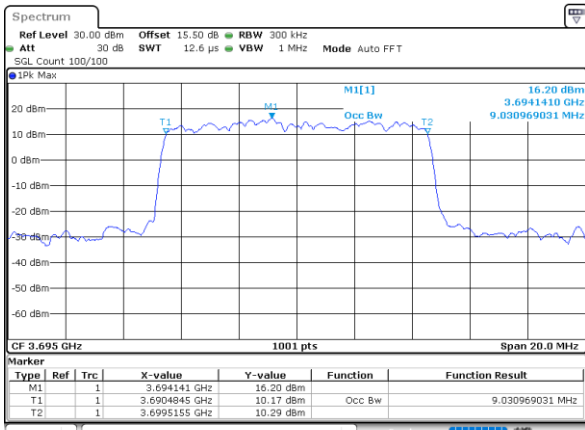

Date: 28.MAR.2023 22:37:27

Highest Channel / 10MHz / 16QAM

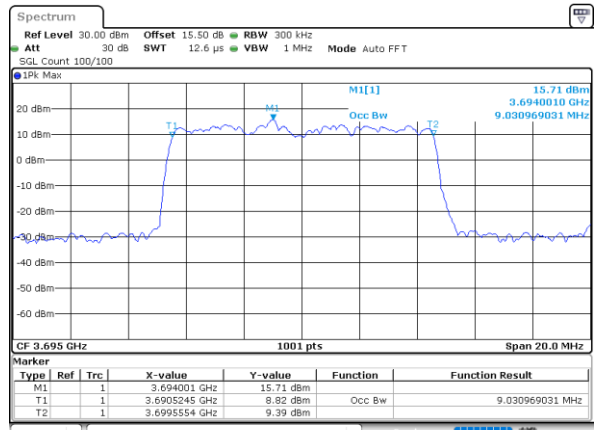

Date: 28.MAR.2023 22:37:51



LTE Band 48

Lowest Channel / 15MHz / QPSK

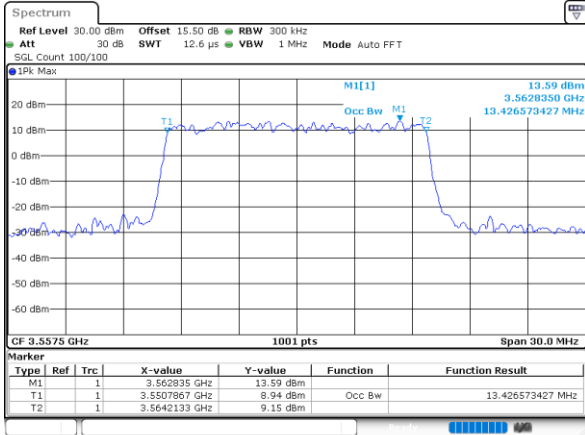

Date: 28.MAR.2023 22:39:04

Lowest Channel / 15MHz / 16QAM

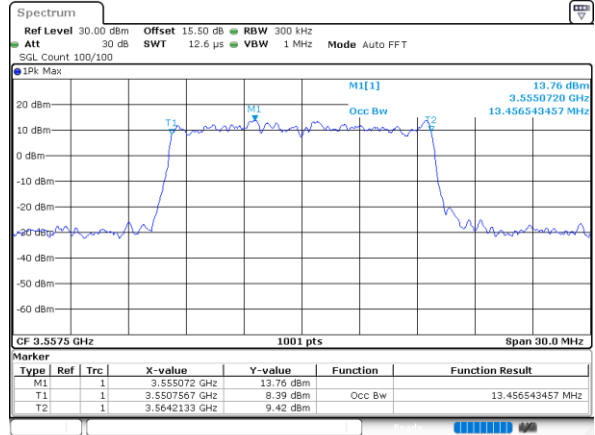

Date: 28.MAR.2023 22:39:28

Middle Channel / 15MHz / QPSK

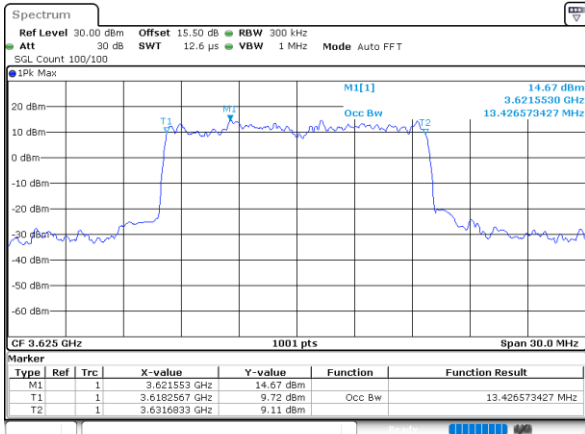

Date: 29.MAR.2023 22:40:40

Middle Channel / 15MHz / 16QAM

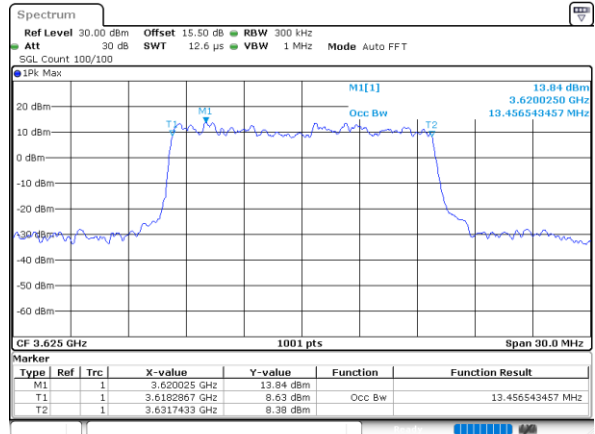

Date: 29.MAR.2023 22:41:03

Highest Channel / 15MHz / QPSK

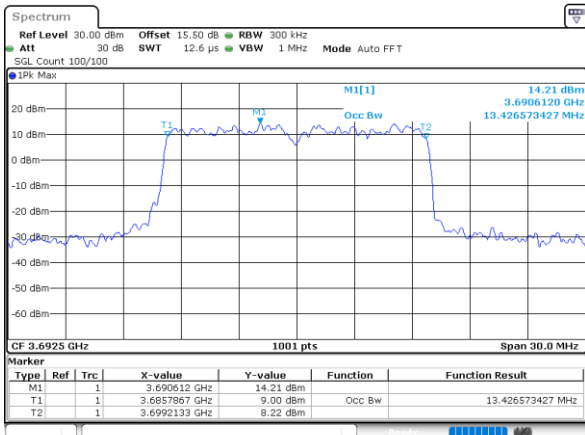

Date: 28.MAR.2023 22:42:14

Highest Channel / 15MHz / 16QAM

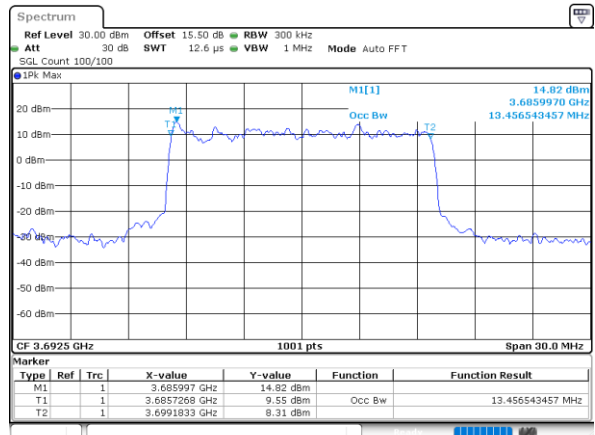

Date: 28.MAR.2023 22:42:38



LTE Band 48

Lowest Channel / 20MHz / QPSK

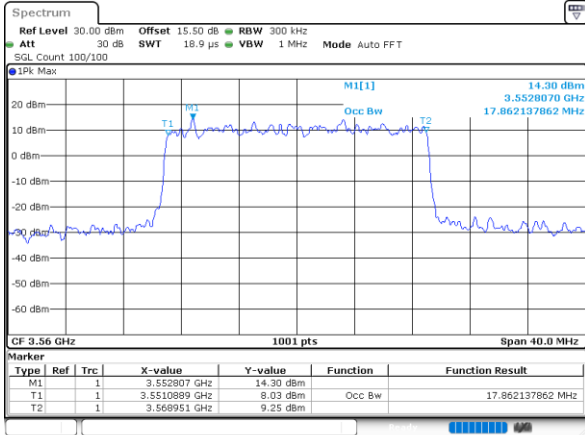

Date: 28.MAR.2023 22:43:52

Lowest Channel / 20MHz / 16QAM

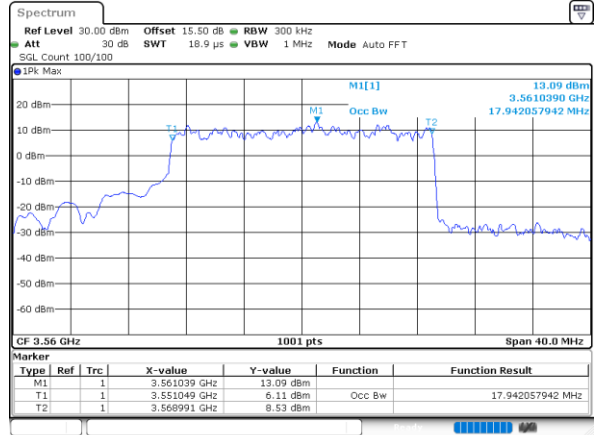

Date: 28.MAR.2023 22:44:16

Middle Channel / 20MHz / QPSK

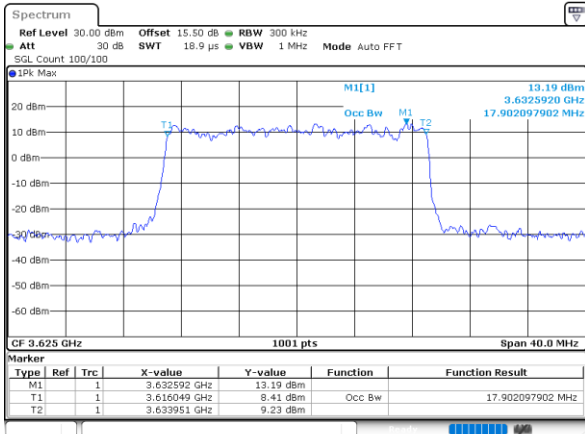

Date: 28.MAR.2023 22:45:27

Middle Channel / 20MHz / 16QAM

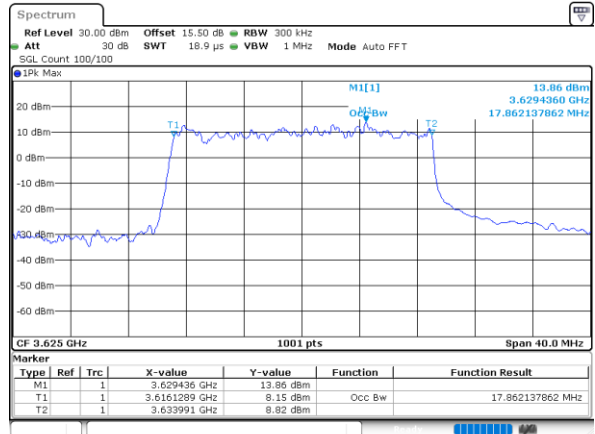

Date: 28.MAR.2023 22:45:51

Highest Channel / 20MHz / QPSK

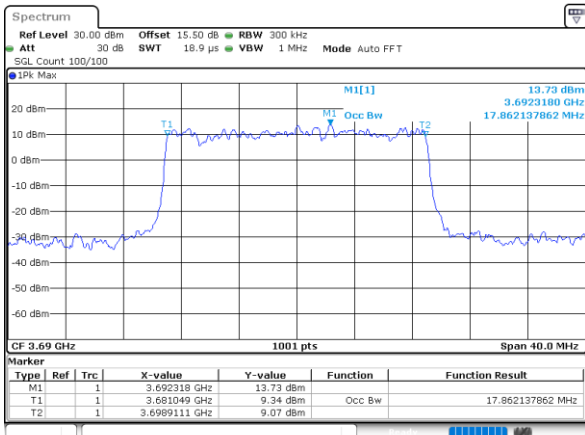

Date: 28.MAR.2023 22:47:01

Highest Channel / 20MHz / 16QAM

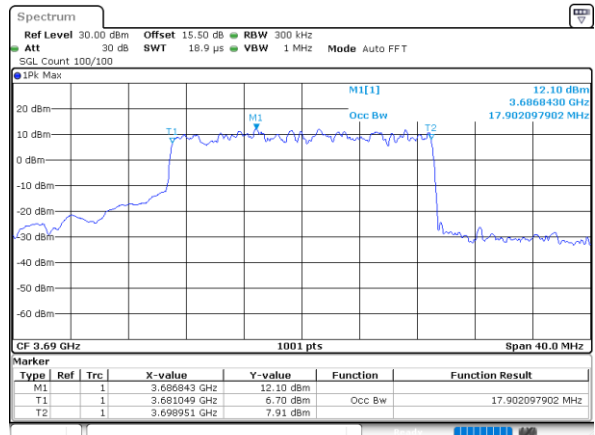

Date: 28.MAR.2023 22:47:25



LTE Band 48

Lowest Channel / 5MHz / 64QAM

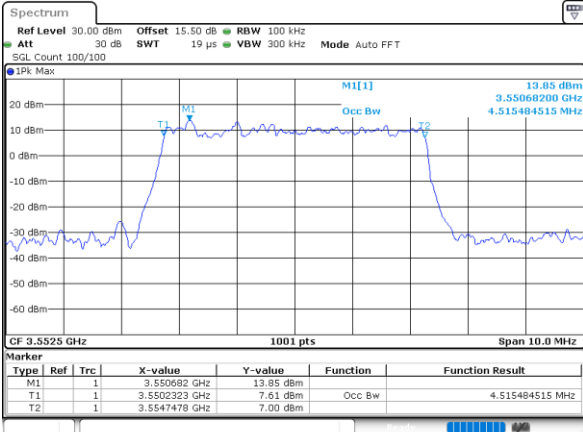

Date: 28.MAR.2023 22:48:39

Lowest Channel / 10MHz / 64QAM

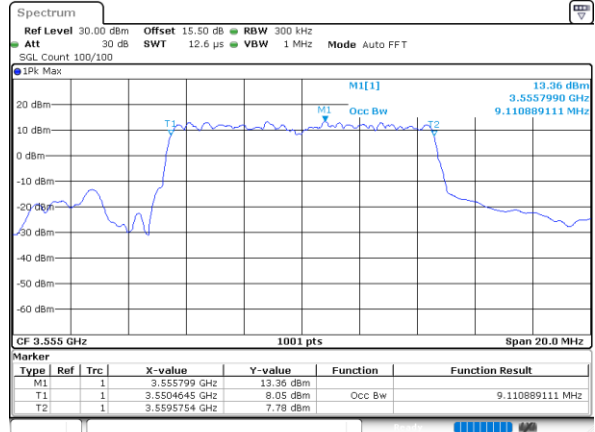

Date: 28.MAR.2023 22:50:36

Middle Channel / 5MHz / 64QAM

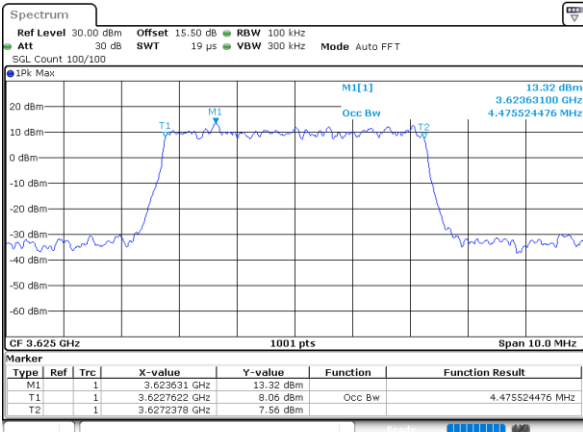

Date: 28.MAR.2023 22:49:17

Middle Channel / 10MHz / 64QAM

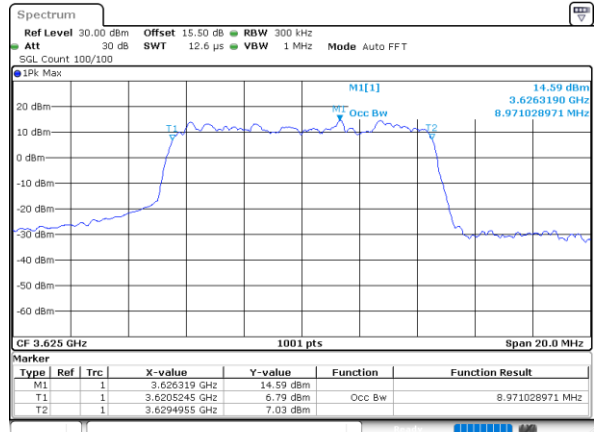

Date: 28.MAR.2023 22:51:14

Highest Channel / 5MHz / 64QAM

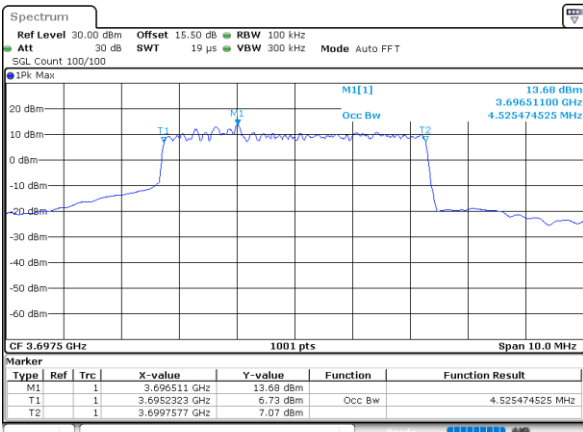

Date: 28.MAR.2023 22:49:55

Highest Channel / 10MHz / 64QAM

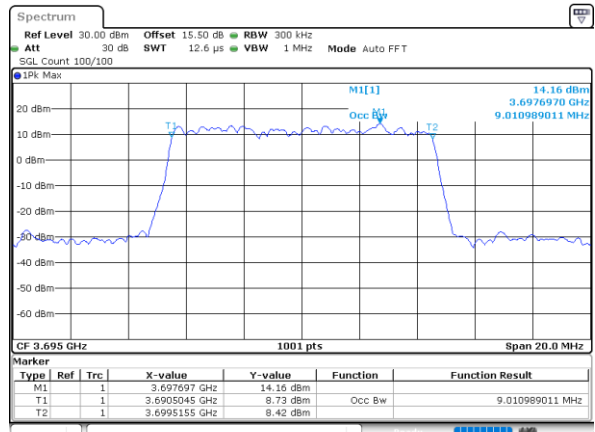

Date: 28.MAR.2023 22:51:52



LTE Band 48

Lowest Channel / 15MHz / 64QAM

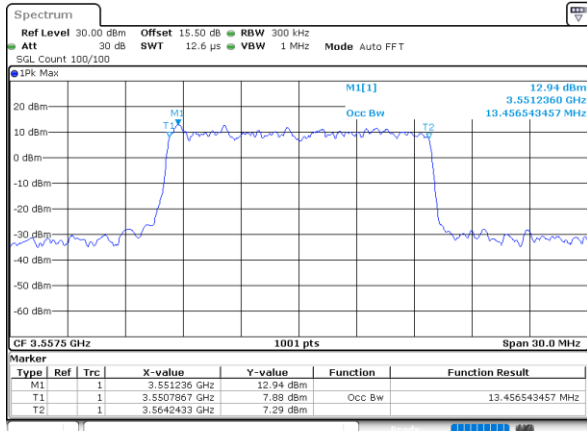

Date: 28.MAR.2023 22:52:32

Lowest Channel / 20MHz / 64QAM

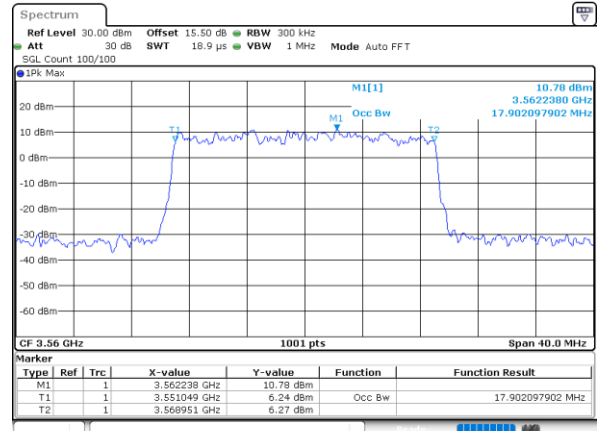

Date: 28.MAR.2023 22:54:30

Middle Channel / 15MHz / 64QAM

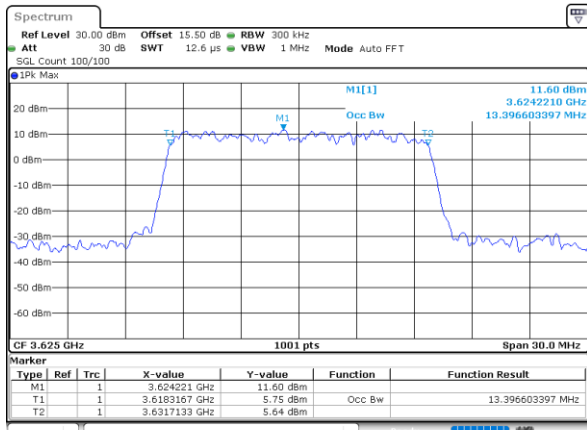

Date: 28.MAR.2023 22:53:11

Middle Channel / 20MHz / 64QAM

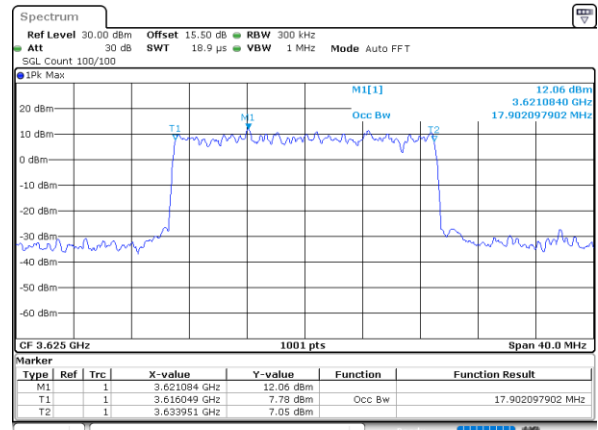

Date: 28.MAR.2023 22:55:08

Highest Channel / 15MHz / 64QAM

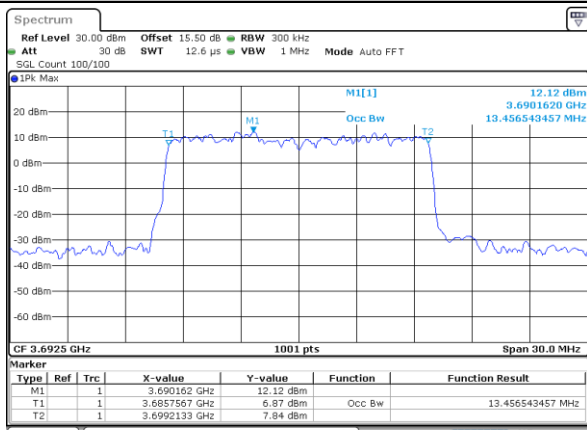

Date: 28.MAR.2023 22:53:50

Highest Channel / 20MHz / 64QAM

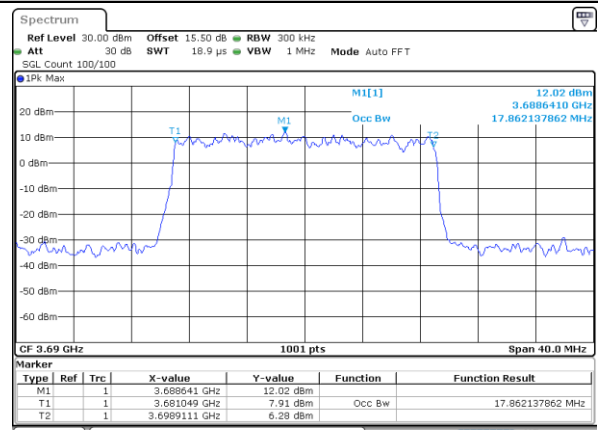

Date: 28.MAR.2023 22:55:46



Conducted Band Edge

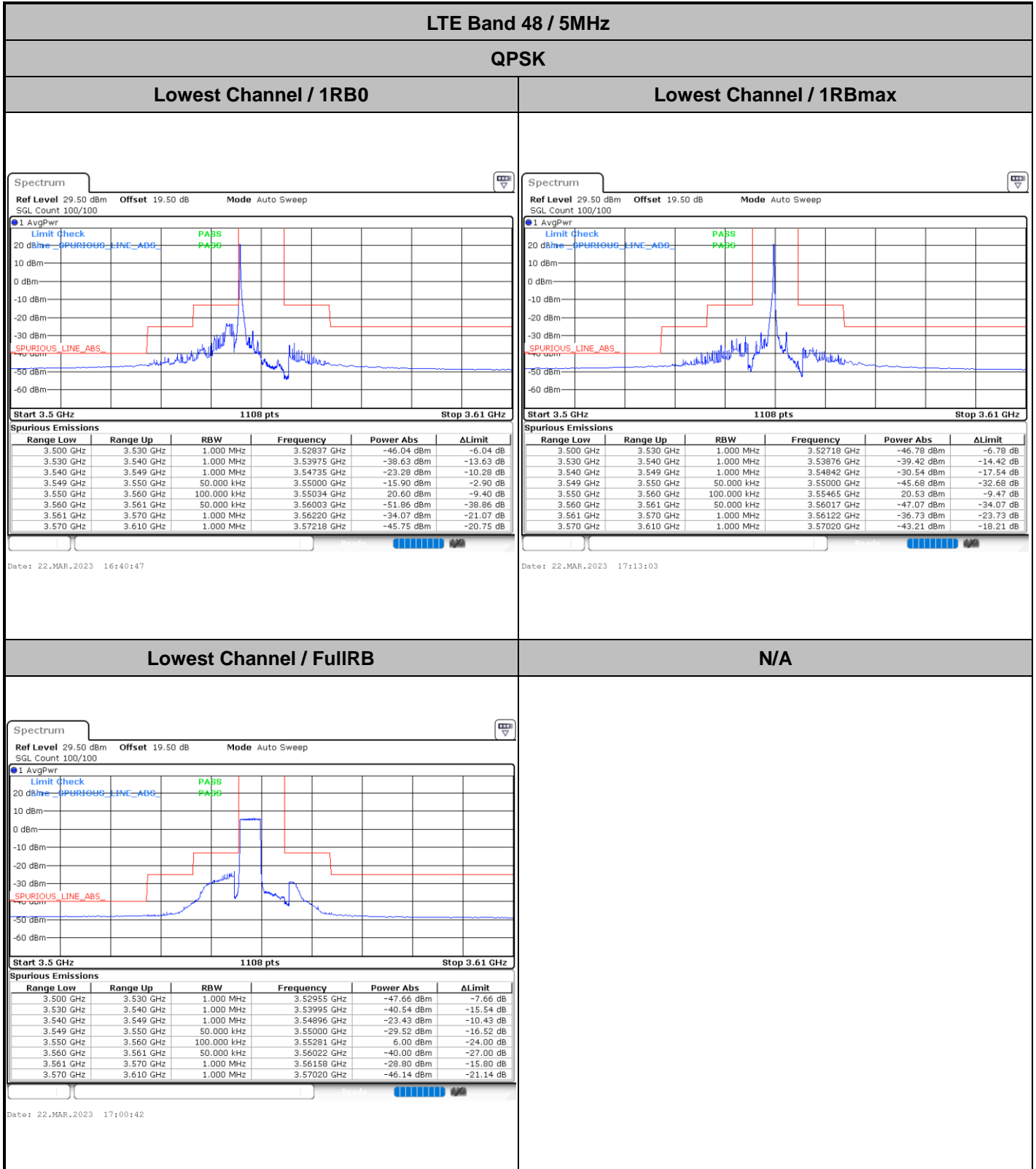



LTE Band 48 / 5MHz

QPSK

Middle Channel / 1RB0

Middle Channel / 1RBmax

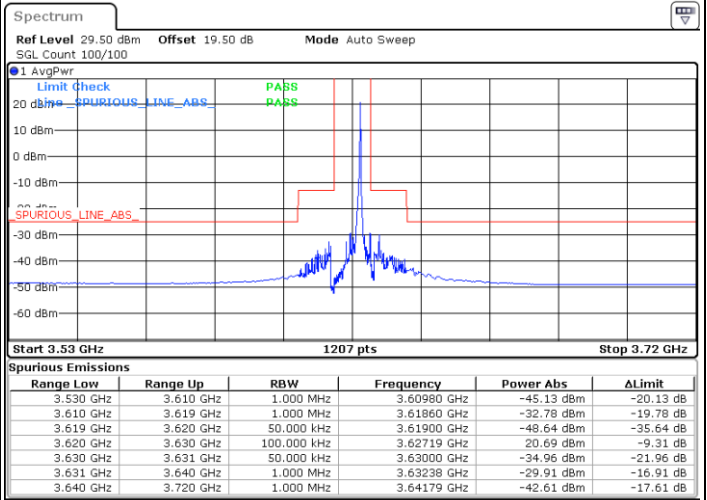
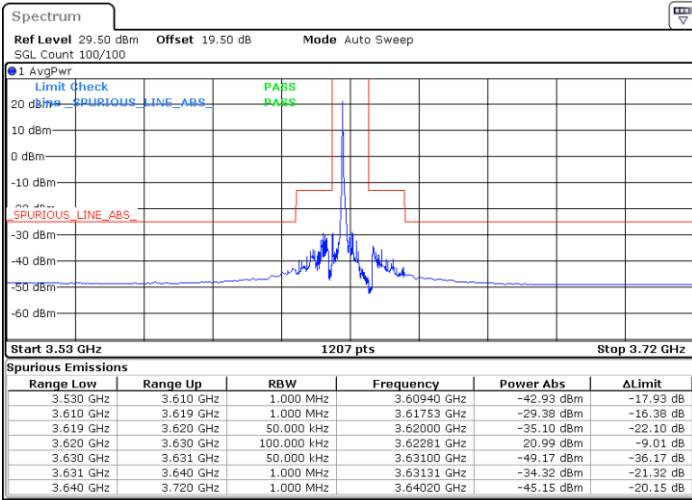

Date: 22.MAR.2023 16:49:53

Date: 22.MAR.2023 17:19:52

Middle Channel / FullIRB

N/A

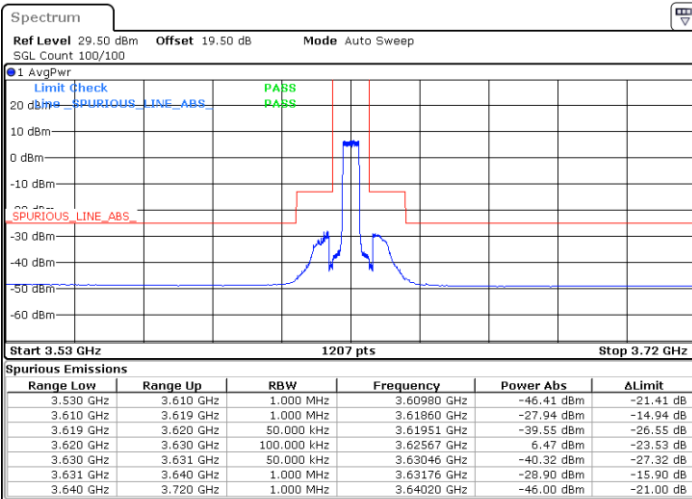

Date: 22.MAR.2023 17:07:35



LTE Band 48 / 5MHz

QPSK

Highest Channel / 1RB0

Highest Channel / 1RBmax

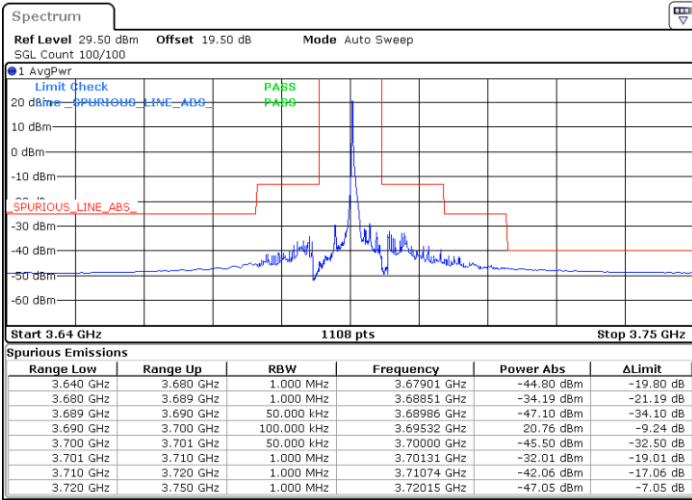

Date: 22.MAR.2023 16:53:43

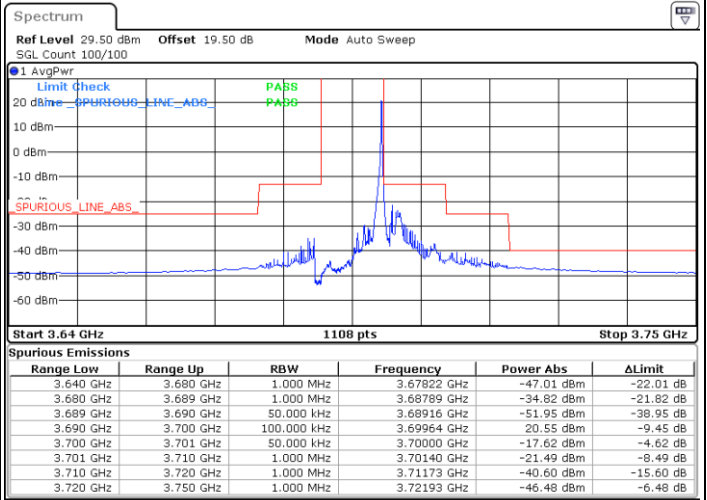

Date: 22.MAR.2023 17:21:14

Highest Channel / FullIRB

N/A

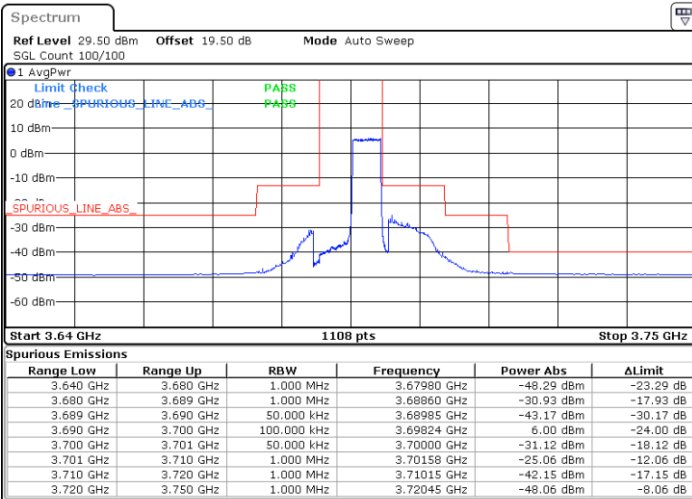

Date: 22.MAR.2023 17:08:57



LTE Band 48 / 10MHz

QPSK

Lowest Channel / 1RB0

Lowest Channel / 1RBmax

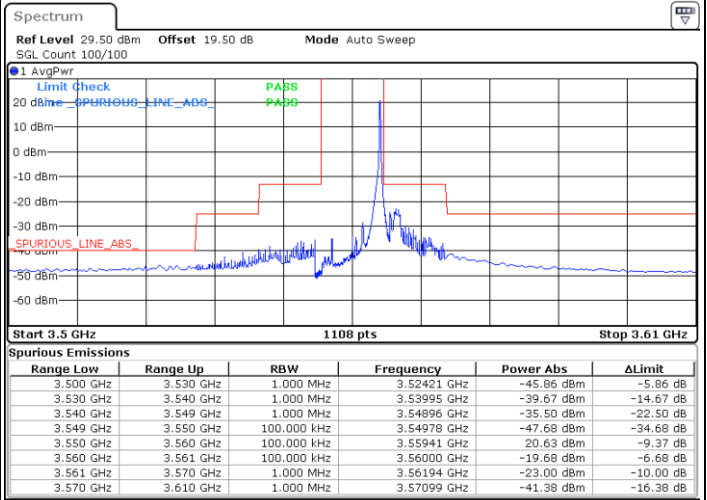
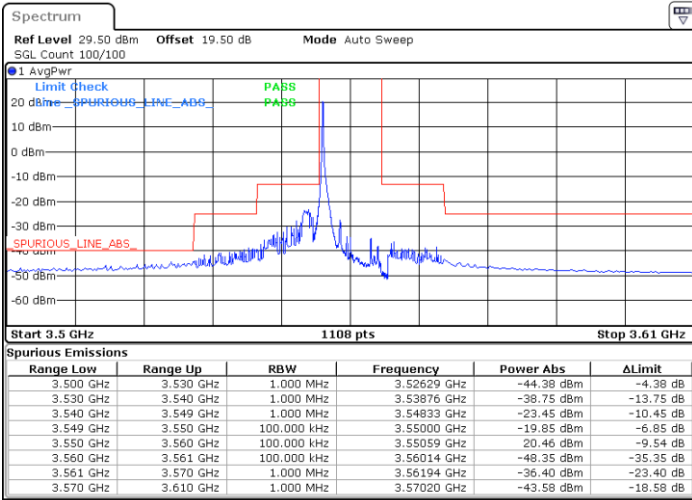

Date: 22.MAR.2023 17:28:05

Date: 22.MAR.2023 19:19:43

Lowest Channel / FullIRB

N/A

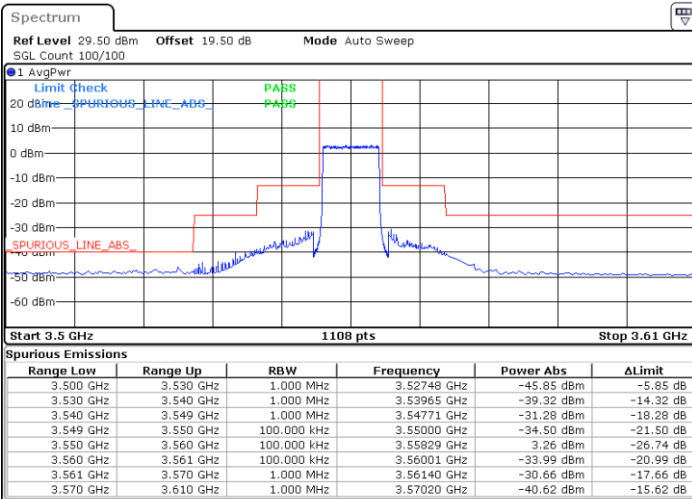

Date: 29.MAR.2023 17:06:15



LTE Band 48 / 10MHz

QPSK

MiddleChannel / 1RB0

Middle Channel / 1RBmax

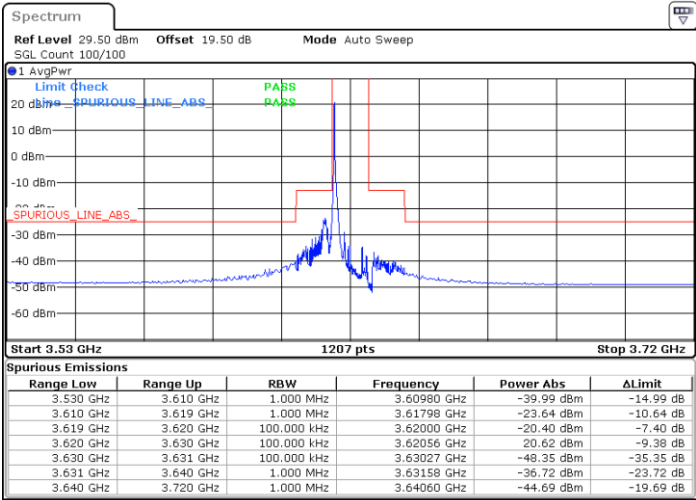

Date: 22.MAR.2023 17:29:27

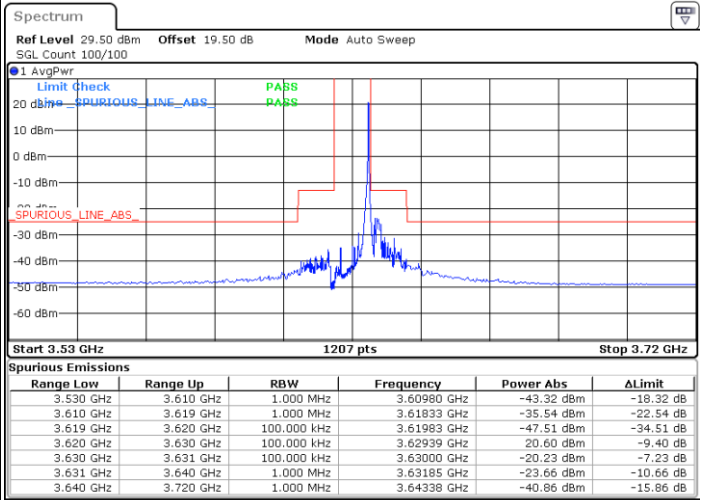

Date: 22.MAR.2023 19:21:05

Middle Channel / FullIRB

N/A

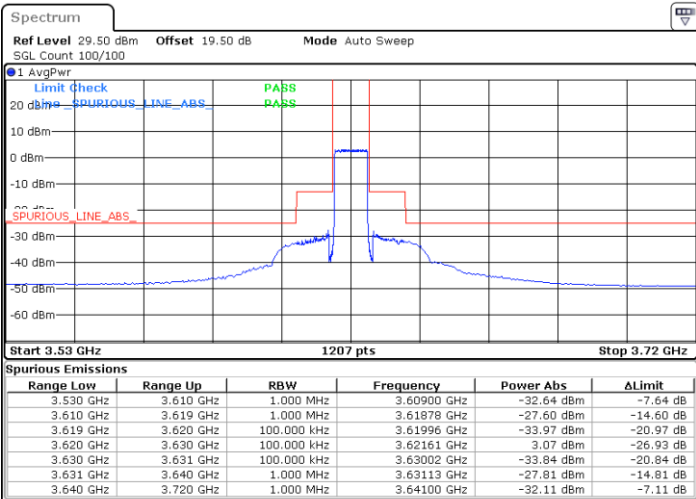

Date: 22.MAR.2023 17:41:44



LTE Band 48 / 10MHz

QPSK

Highest Channel / 1RB0

Highest Channel / 1RBmax

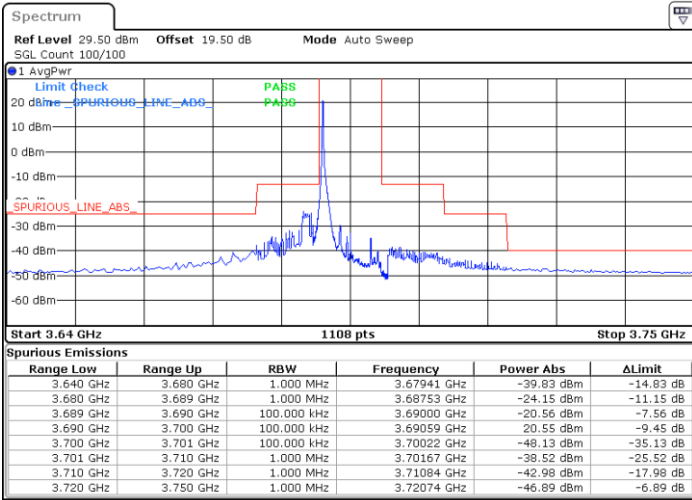

Date: 22.MAR.2023 17:36:16

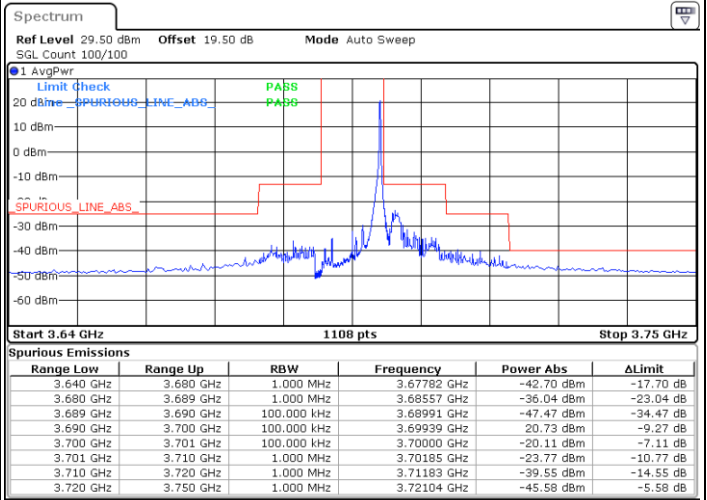

Date: 22.MAR.2023 19:27:56

Highest Channel / FullIRB

N/A

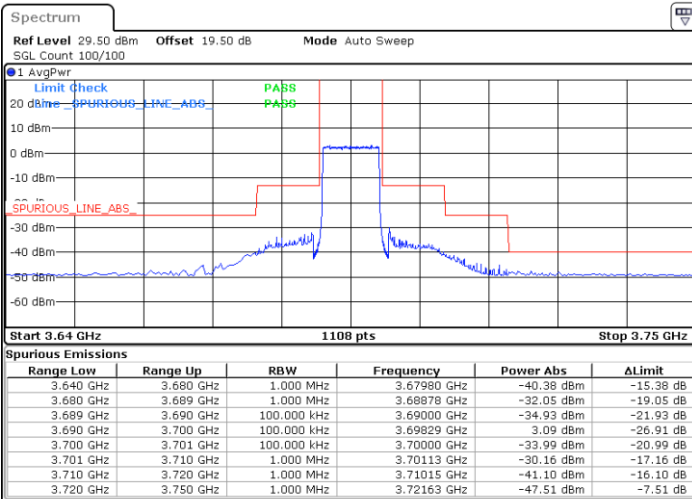

Date: 29.MAR.2023 17:07:19



LTE Band 48 / 15MHz

QPSK

Lowest Channel / 1RB0

Lowest Channel / 1RBmax

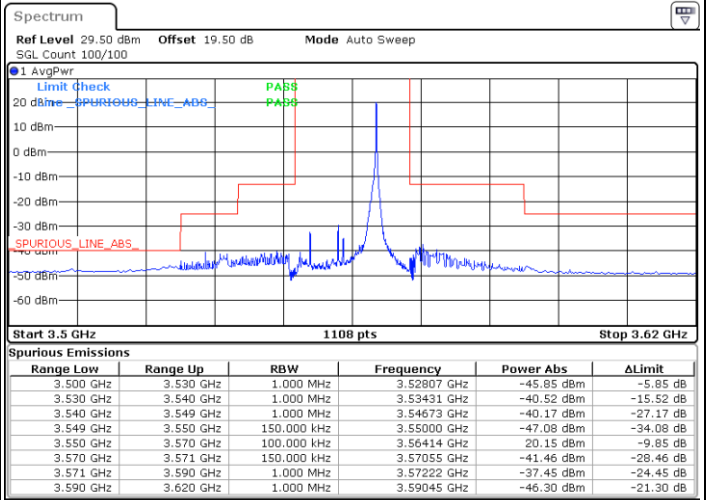
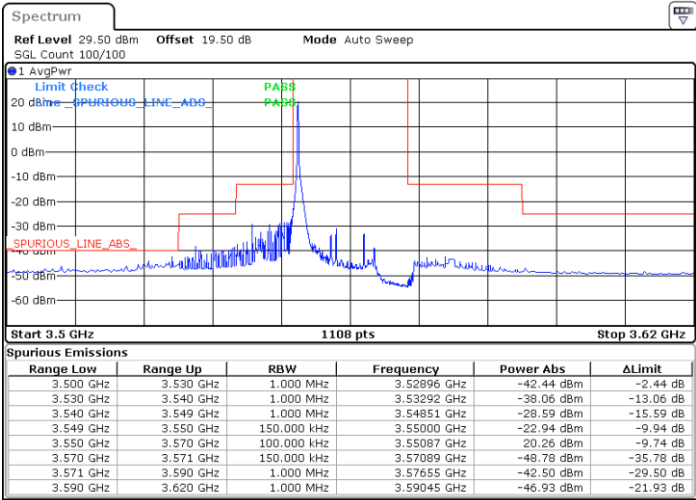

Date: 29.MAR.2023 17:48:12

Date: 29.MAR.2023 17:54:52

Lowest Channel / FullIRB

N/A

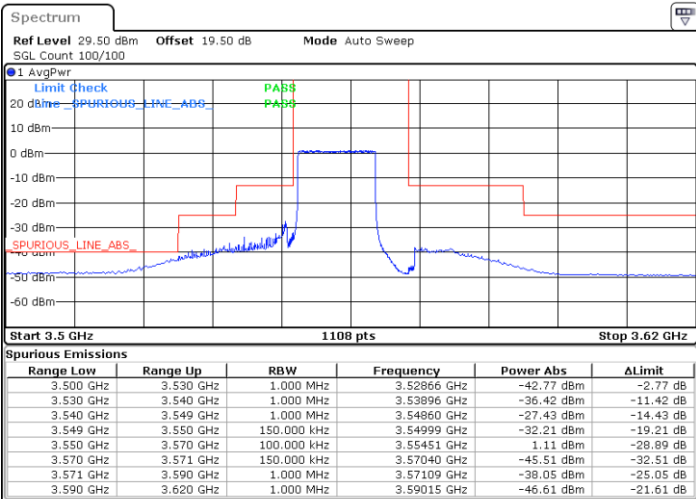

Date: 29.MAR.2023 17:53:23



LTE Band 48 / 15MHz

QPSK

Middle Channel / 1RB0

Middle Channel / 1RBmax

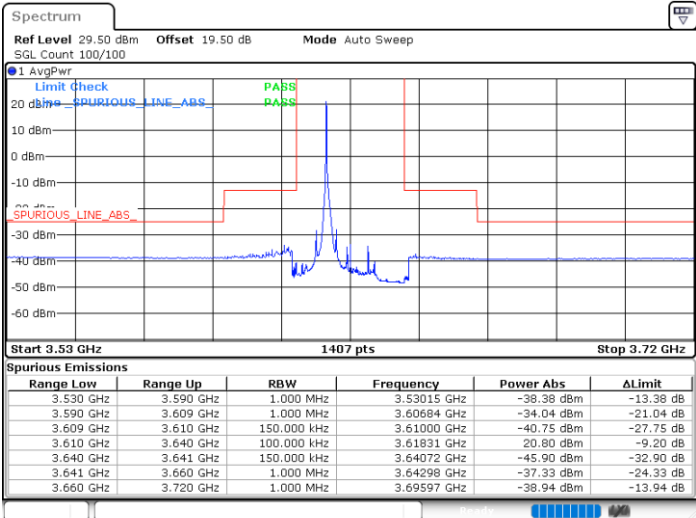

Date: 23.MAR.2023 13:05:58

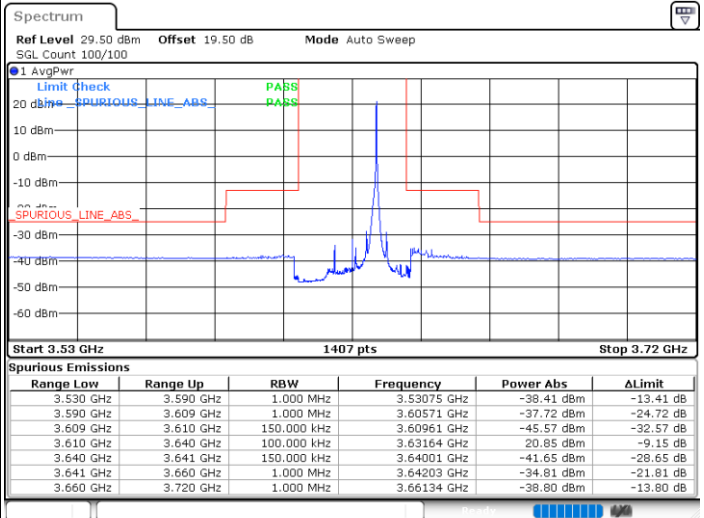

Date: 23.MAR.2023 13:33:33

Middle Channel / FullIRB

N/A

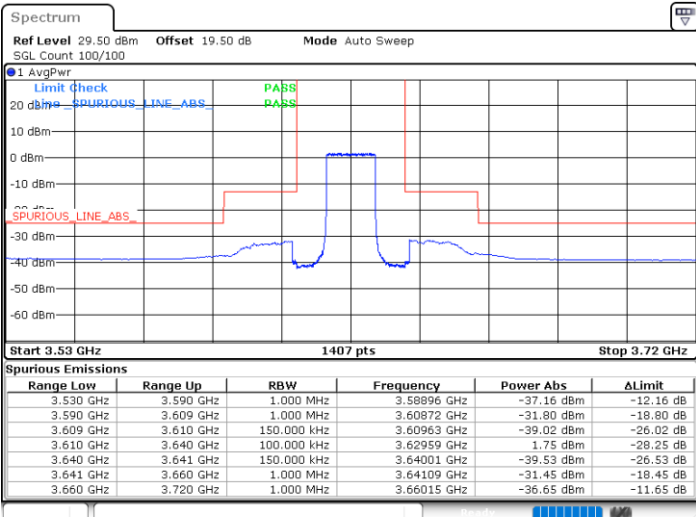

Date: 23.MAR.2023 13:19:45



LTE Band 48 / 15MHz

QPSK

Highest Channel / 1RB0

Highest Channel / 1RBmax

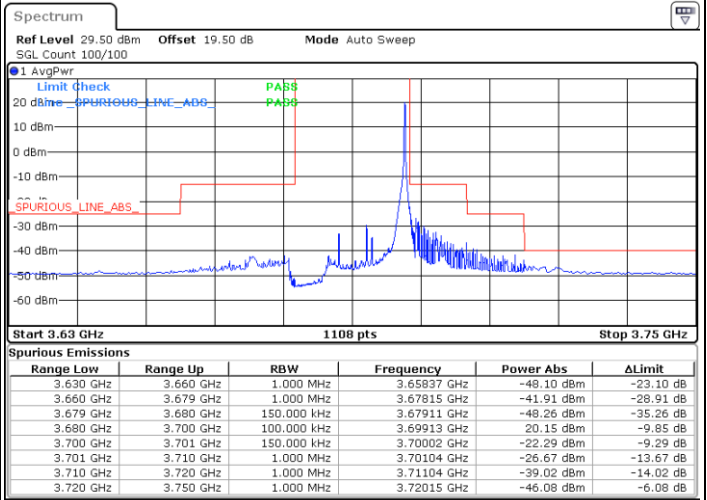
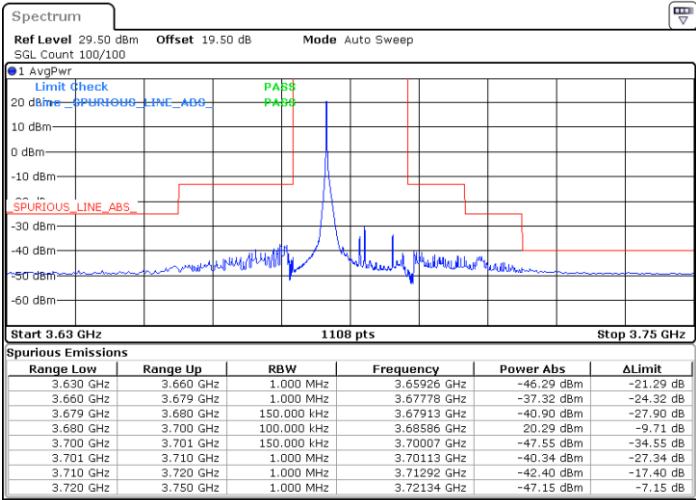

Date: 29.MAR.2023 18:06:12

Date: 29.MAR.2023 18:04:21

Highest Channel / FullIRB

N/A

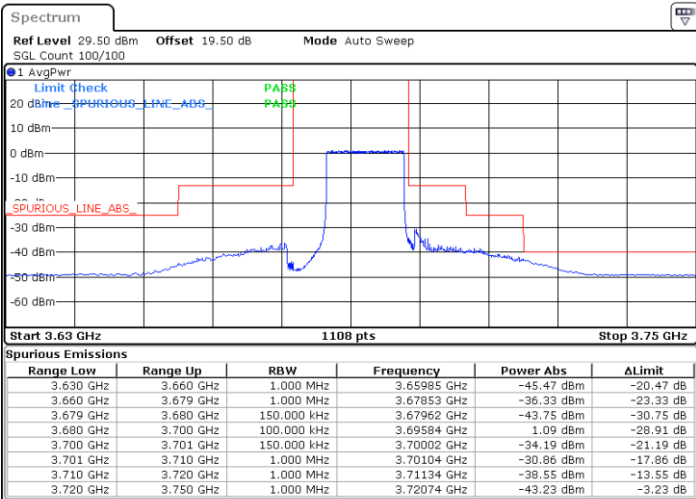

Date: 29.MAR.2023 18:13:12