



# FCC RF Test Report

**APPLICANT** : Motorola Mobility LLC  
**EQUIPMENT** : Mobile Cellular Phone  
**BRAND NAME** : Motorola  
**MODEL NAME** : XT2305-1  
**FCC ID** : IHDT56AL5  
**STANDARD** : 47 CFR Part 2, Part 27 Subpart Q  
**CLASSIFICATION** : PCS Licensed Transmitter Held to Ear (PCE)  
**TEST DATE(S)** : Mar. 10, 2023 ~ Apr. 14, 2023

We, Sporton International Inc. (KunShan), would like to declare that the tested sample has been evaluated in accordance with the procedures given in ANSI C63.26-2015 and shown compliance with the applicable technical standards.

This report contains data that were produced under subcontract by Sporton International Inc. (Shenzhen).

The test results in this report apply exclusively to the tested model / sample. Without written approval of Sporton International Inc. (KunShan), the test report shall not be reproduced except in full.

Jason Jia



Approved by: Jason Jia

**Sporton International Inc. (Kunshan)**

**No. 1098, Pengxi North Road, Kunshan Economic Development Zone Jiangsu Province 215300  
People's Republic of China**



TABLE OF CONTENTS

REVISION HISTORY..... 3
SUMMARY OF TEST RESULT ..... 4
1 GENERAL DESCRIPTION ..... 5
1.1 Applicant ..... 5
1.2 Manufacturer ..... 5
1.3 Product Feature of Equipment Under Test ..... 5
1.4 Product Specification of Equipment Under Test ..... 5
1.5 Specification of Accessory ..... 6
1.6 Modification of EUT ..... 6
1.7 Maximum EIRP Power and Emission Designator ..... 7
1.8 Testing Site ..... 9
1.9 Test Software ..... 9
1.10 Applied Standards ..... 10
2 TEST CONFIGURATION OF EQUIPMENT UNDER TEST ..... 11
2.1 Test Mode ..... 11
2.2 Connection Diagram of Test System ..... 12
2.3 Support Unit used in test configuration and system ..... 12
2.4 Measurement Results Explanation Example ..... 12
2.5 Frequency List of Low/Middle/High Channels ..... 13
3 CONDUCTED TEST ITEMS ..... 15
3.1 Measuring Instruments ..... 15
3.2 Test Setup ..... 15
3.3 Test Result of Conducted Test ..... 15
3.4 Conducted Output Power Measurement ..... 16
3.5 Peak-to-Average Ratio ..... 17
3.6 EIRP ..... 18
3.7 Occupied Bandwidth ..... 19
3.8 Conducted Band Edge Measurement ..... 20
3.9 Conducted Spurious Emission Measurement ..... 21
3.10 Frequency Stability Measurement ..... 22
4 RADIATED TEST ITEMS ..... 23
4.1 Measuring Instruments ..... 23
4.2 Test Setup ..... 23
4.3 Test Result of Radiated Test ..... 24
4.4 Radiated Spurious Emission Measurement ..... 25
5 LIST OF MEASURING EQUIPMENT ..... 26
6 UNCERTAINTY OF EVALUATION ..... 27
APPENDIX A. TEST RESULTS OF CONDUCTED TEST
APPENDIX B. TEST RESULTS OF RADIATED TEST
APPENDIX C. TEST SETUP PHOTOGRAPHS





### SUMMARY OF TEST RESULT

Report Section	FCC Rule	Description	Limit	Result	Remark
3.4	§2.1046	Conducted Output Power	—	Report Only	-
3.5	§27.50 (k)(4)	Peak-to-Average Ratio	<13dB	PASS	
3.6	§27.50 (k)(3)	EIRP	EIRP < 1W (30dBm)	PASS	-
3.7	§2.1049	Occupied Bandwidth	—	Report Only	-
3.8	§2.1051 §27.53 (n)(2)	Conducted Band Edge Measurement	-13dBm/MHz	PASS	-
3.9	§2.1051 §27.53 (n)(2)	Conducted Spurious Emission	-13dBm/MHz	PASS	-
3.10	§2.1055 §27.54	Frequency Stability Temperature & Voltage	Within the band	PASS	-
4.4	§2.1053 §27.53 (n)(2)	Radiated Spurious Emission	-13dBm/MHz	PASS	Under limit 43.01 dB at 10356.00 MHz

**Declaration of Conformity:**  
The test results with all measurement uncertainty excluded are presented in accordance with the regulation limits or requirements declared by manufacturers.

**Comments and Explanations:**  
The declared of product specification for EUT presented in the report are provided by the manufacturer, and the manufacturer takes all the responsibilities for the accuracy of product specification.



# 1 General Description

## 1.1 Applicant

**Motorola Mobility LLC**  
222 W,Merchandise Mart Plaza, Chicago IL 60654 USA

## 1.2 Manufacturer

**Motorola Mobility LLC**  
222 W,Merchandise Mart Plaza, Chicago IL 60654 USA

## 1.3 Product Feature of Equipment Under Test

Product Feature	
<b>Equipment</b>	Mobile Cellular Phone
<b>Brand Name</b>	Motorola
<b>Model Name</b>	XT2305-1
<b>FCC ID</b>	IHDT56AL5
<b>IMEI Code</b>	Conducted : 351048560017430, 351072410011450 Radiation : 351048560020038/351048560020046
<b>HW Version</b>	DVT2
<b>SW Version</b>	TTT33.46
<b>EUT Stage</b>	Identical Prototype

## 1.4 Product Specification of Equipment Under Test

Product Feature	
<b>Tx/Rx Frequency</b>	5G NR n77: 3450 MHz ~ 3550 MHz 5G NR n78: 3450 MHz ~ 3550 MHz
<b>SCS</b>	15kHz, 30kHz
<b>Bandwidth</b>	n77/n78(15kHz): 10 / 15 / 20 / 25 / 30 / 40 / 50MHz n77/n78(30kHz): 10 / 15 / 20 / 25 / 30 / 40 / 50 / 60 / 70 / 80 / 90 / 100MHz
<b>Antenna Gain</b>	<b>&lt;Ant. 2&gt;</b> 5G NR n77: -9.2 dBi 5G NR n78: -9.2 dBi <b>&lt;Ant. 4&gt;</b> 5G NR n77: -8.8 dBi 5G NR n78: -8.8 dBi <b>&lt;Ant. 5&gt;</b> 5G NR n77: -11.5 dBi 5G NR n78: -11.5 dBi <b>&lt;Ant. 7&gt;</b> 5G NR n77: -10.3 dBi 5G NR n78: -10.3 dBi
<b>Type of Modulation</b>	CP-OFDM: QPSK / 16QAM / 64QAM / 256QAM DFT-s-OFDM: PI/2 BPSK / QPSK / 16QAM / 64QAM / 256QAM

**Remark:**

1. The maximum EIRP is calculated from max output power and max antenna gain, only the maximum EIRP of Ant.4 for n77/n78 SISO, and Ant.(4+2) for n77/n78 MIMO are shown in the report.
2. The device supports n77/n78(1T4R) SRS resources on Ant.2/4/5/7, only the test data of worst Ant.4 is showed in the report according to the maximum power.
3. The device supports HPUE(PC2) mode for 5G NR n77, and HPUE(PC1.5) mode for n77 MIMO.
4. 5G NR n77/n78 support UL MIMO mode for Ant(4+2)/ Ant(4+5) / Ant(7+2) / Ant(7+5), only the worst test data of Ant.(4+2) is shown in the report.
5. For n77/n78 MIMO mode, the Ant (4+2) MIMO Gain =  $10 \log[(10^{\text{Ant.4}/20} + 10^{\text{Ant.2}/20})^2 / 2] = -5.99\text{dBi}$ .
6. For n77/n78 MIMO mode, the conducted BE/Spurious are tested at single antenna port and add  $10 \cdot \log(N_{\text{ANT}})$  according to KDB 662911 D01.
7. 5G NR n77/n78 support SA and NSA mode. The whole testing has assessed SA mode by referring to the higher conducted power for conducted test items.
8. All the supported EN-DC combinations are verified conducted power, only the EN-DC combination with highest power are shown in the report.
9. The EN-DC mode combination could be referred to the product spec.

## 1.5 Specification of Accessory

Specification of Accessory				
AC Adapter 1	Brand Name	Motorola(Chenyang)	Model Name	MC-681N
AC Adapter 2	Brand Name	Motorola(Acbel)	Model Name	MC-681N
Battery	Brand Name	Motorola(AmpereX)	Model Name	PG44
USB Cable 1	Brand Name	Motorola (Saibao)	Model Name	SC18D86731
USB Cable 2	Brand Name	Motorola (Saibao)	Model Name	SC18D71644

## 1.6 Modification of EUT

No modifications are made to the EUT during all test items.

### 1.7 Maximum EIRP Power and Emission Designator

5G NR n77 UL MIMO for SCS 15kHz		PI/2 BPSK / QPSK		16QAM/64QAM/256QAM	
BW (MHz)	Frequency Range (MHz)	Maximum EIRP(W)	Emission Designator (99%OBW)	Maximum EIRP(W)	Emission Designator (99%OBW)
10	3455.01 ~ 3544.995	0.1828	9M28G7D	0.1442	9M30W7D
15	3457.50 ~ 3542.49	0.1837	14M1G7D	0.1459	14M1W7D
20	3460.005 ~ 3540.00	0.1841	18M9G7D	0.1489	18M9W7D
25	3462.51 ~ 3537.495	0.1862	23M7G7D	0.1466	23M8W7D
30	3465.00 ~ 3534.99	0.1892	28M6G7D	0.1483	28M6W7D
40	3470.01 ~ 3529.995	0.1871	38M7G7D	0.1483	38M6W7D
50	3475.005 ~ 3525.00	0.1950	48M3G7D	0.1510	48M2W7D

5G NR n77 UL MIMO for SCS 30kHz		PI/2 BPSK / QPSK		16QAM/64QAM/256QAM	
BW (MHz)	Frequency Range (MHz)	Maximum EIRP(W)	Emission Designator (99%OBW)	Maximum EIRP(W)	Emission Designator (99%OBW)
10	3455.01 ~ 3544.98	0.1858	8M59G7D	0.1368	8M60W7D
15	3457.50 ~ 3542.49	0.1884	13M6G7D	0.1390	13M6W7D
20	3460.02 ~ 3540.00	0.1884	18M2G7D	0.1393	18M2W7D
25	3462.51 ~ 3537.48	0.1866	23M3G7D	0.1352	23M2W7D
30	3465.00 ~ 3534.99	0.1892	27M9G7D	0.1409	27M9W7D
40	3470.01 ~ 3529.98	0.1892	37M8G7D	0.1435	37M9W7D
50	3475.02 ~ 3525.00	0.1901	47M4G7D	0.1483	47M5W7D
60	3480.00 ~ 3519.99	0.1928	58M0G7D	0.1469	57M8W7D
70	3485.01 ~ 3514.98	0.1936	67M6G7D	0.1469	67M5W7D
80	3490.02 ~ 3510.00	0.1936	77M5G7D	0.1479	77M6W7D
90	3495.00 ~ 3504.99	0.1932	87M7G7D	0.1479	87M7W7D
100	3500.01	0.1941	97M7G7D	0.1483	97M7W7D

5G NR n78 UL MIMO for SCS 15kHz		PI/2 BPSK / QPSK		16QAM/64QAM/256QAM	
BW (MHz)	Frequency Range (MHz)	Maximum EIRP(W)	Emission Designator (99%OBW)	Maximum EIRP(W)	Emission Designator (99%OBW)
10	3455.01 ~ 3544.995	0.0547	9M28G7D	0.0417	9M30W7D
15	3457.50 ~ 3542.49	0.0543	14M1G7D	0.0443	14M1W7D
20	3460.005 ~ 3540.00	0.0555	18M9G7D	0.0428	18M9W7D
25	3462.51 ~ 3537.495	0.0561	23M7G7D	0.0458	23M8W7D
30	3465.00 ~ 3534.99	0.0568	28M6G7D	0.0490	28M6W7D
40	3470.01 ~ 3529.995	0.0568	38M7G7D	0.0455	38M6W7D
50	3475.005 ~ 3525.00	0.0575	48M3G7D	0.0449	48M2W7D

5G NR n78 UL MIMO for SCS 30kHz		PI/2 BPSK / QPSK		16QAM/64QAM/256QAM	
BW (MHz)	Frequency Range (MHz)	Maximum EIRP(W)	Emission Designator (99%OBW)	Maximum EIRP(W)	Emission Designator (99%OBW)
10	3455.01 ~ 3544.98	0.0521	8M59G7D	0.0413	8M60W7D
15	3457.50 ~ 3542.49	0.0533	13M6G7D	0.0415	13M6W7D
20	3460.02 ~ 3540.00	0.0533	18M2G7D	0.0411	18M2W7D
25	3462.51 ~ 3537.48	0.1866	23M3G7D	0.1352	23M2W7D
30	3465.00 ~ 3534.99	0.0522	27M9G7D	0.0412	27M9W7D
40	3470.01 ~ 3529.98	0.0526	37M8G7D	0.0412	37M9W7D
50	3475.02 ~ 3525.00	0.0526	47M4G7D	0.0413	47M5W7D
60	3480.00 ~ 3519.99	0.0526	58M0G7D	0.0396	57M8W7D
70	3485.01 ~ 3514.98	0.0526	67M6G7D	0.0416	67M5W7D
80	3490.02 ~ 3510.00	0.0532	77M5G7D	0.0422	77M6W7D
90	3495.00 ~ 3504.99	0.0522	87M7G7D	0.0413	87M7W7D
100	3500.01	0.0543	97M7G7D	0.0424	97M7W7D

**Note:**

1. 5G NR Band n77 overlaps the entire frequency range of Band n78, and n77 power > n78 power, therefore the conducted test results of n77 provided in this report cover n78.
2. All modulations have been tested, and only the worst test results of PSK & QAM are shown in the report.

### 1.8 Testing Site

Sporton International Inc. (Kunshan) is accredited to ISO/IEC 17025:2017 by American Association for Laboratory Accreditation with Certificate Number 5145.02.

<b>Test Firm</b>	Sporton International Inc. (Kunshan)		
<b>Test Site Location</b>	No. 1098, Pengxi North Road, Kunshan Economic Development Zone Jiangsu Province 215300 People's Republic of China TEL : +86-512-57900158		
<b>Test Site No.</b>	<b>Sporton Site No.</b>	<b>FCC Designation No.</b>	<b>FCC Test Firm Registration No.</b>
	03CH04-KS	CN1257	314309

Sporton International Inc. (ShenZhen) is accredited to ISO/IEC 17025:2017 by American Association for Laboratory Accreditation with Certificate Number 5145.01.

<b>Test Firm</b>	Sporton International Inc. (ShenZhen)		
<b>Test Site Location</b>	1/F, 2/F, Bldg 5, Shiling Industrial Zone, Xinwei Village, Xili, Nanshan, Shenzhen, 518055 People's Republic of China TEL: +86-755-86379589 FAX: +86-755-86379595		
<b>Test Site No.</b>	<b>Sporton Site No.</b>	<b>FCC Designation No.</b>	<b>FCC Test Firm Registration No.</b>
	TH01-SZ	CN1256	421272

Test data subcontracted: Conducted test case in section 3 of this report.

### 1.9 Test Software

Item	Site	Manufacturer	Name	Version
1.	03CH04-KS	AUDIX	E3	6.2009-8-24al



## 1.10 Applied Standards

According to the specifications of the manufacturer, the EUT must comply with the requirements of the following standards:

- ♦ 47 CFR Part 2, Part 27 Subpart Q
- ♦ ANSI C63.26-2015
- ♦ FCC KDB 971168 Power Meas License Digital Systems D01 v03r01
- ♦ FCC KDB 412172 D01 Determining ERP and EIRP v01r01

**Remark:**

1. All test items were verified and recorded according to the standards and without any deviation during the test.
2. This EUT has also been tested and complied with the requirements of FCC Part 15, Subpart B, recorded in a separate test report.

## 2 Test Configuration of Equipment Under Test

### 2.1 Test Mode

Antenna port conducted and radiated test items listed below are performed according to KDB 971168 D01 Power Meas. License Digital Systems v03r01 with maximum output power.

Radiated measurements are performed by rotating the EUT in three different orthogonal test planes( X, Y, Z plane) to find the maximum emission(X plane).

Test Cases	Band	Bandwidth (MHz)	Modulation	RB #	Test Channel
		eg. 5M, 10M, 15M, 20M	eg. PI/2 BPSK, QPSK, 16QAM, 64QAM, 256QAM	1RB, Partial RB, Full RB	L/M/H
Max. Output Power	5G n77	10M, 15M, 20M, 25M, 30M, 40M, 50M, 60M, 70M, 80M, 90M, 100M	All Modulations	1RB, Full RB	L, M, H
	5G n78	10M, 15M, 20M, 25M, 30M, 40M, 50M, 60M, 70M, 80M, 90M, 100M	All Modulations	1RB, Full RB	L, M, H
Peak-to-Average Ratio	5G n77	20M	PI/2 BPSK, QPSK	1RB, Full RB	L, M, H
E.I.R.P	5G n77	10M, 15M, 20M, 25M, 30M, 40M, 50M, 60M, 70M, 80M, 90M, 100M	All Modulations	1RB, Full RB	L, M, H
	5G n78	10M, 15M, 20M, 25M, 30M, 40M, 50M, 60M, 70M, 80M, 90M, 100M	All Modulations	1RB, Full RB	L, M, H
26dB and 99% Bandwidth	5G n77	10M, 15M, 20M, 25M, 30M, 40M, 50M, 60M, 70M, 80M, 90M, 100M	All Modulations	Full RB	M
Conducted Band Edge	5G n77	10M, 25M/50M, 100M	PI/2 BPSK, QPSK	1RB, Full RB	L, H
Conducted Spurious Emission	5G n77	10M, 25M/50M, 100M	PI/2 BPSK, QPSK	1RB	L, M, H
Frequency Stability	5G n77	20M	QPSK	Full RB	M
Radiated Spurious Emission	5G n77	Worst case from maximum power			L, M, H

**Note:**

- The device is investigated from 30MHz to 10 times of fundamental signal for radiated spurious emission test under different RB size/offset and modulations in exploratory test. Subsequently, only the worst case emissions are reported.
- Frequency Stability: Normal Voltage = 3.91V ; Low Voltage =3.40V.; High Voltage =4.50V.

## 2.2 Connection Diagram of Test System

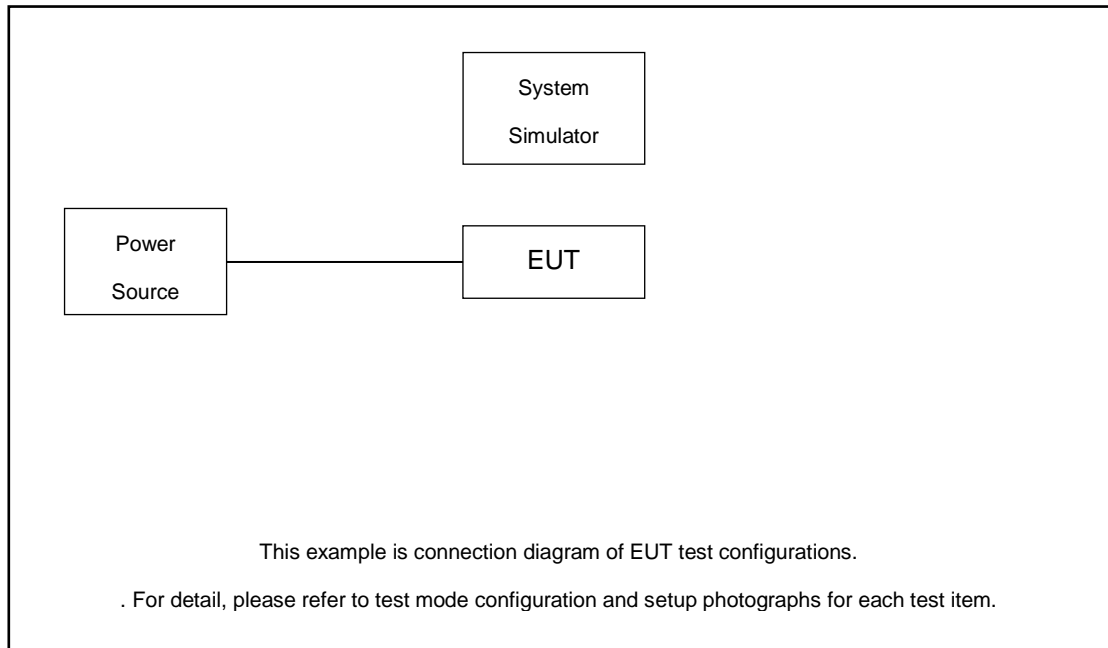

## 2.3 Support Unit used in test configuration and system

Item	Equipment	Trade Name	Model No.	FCC ID	Data Cable	Power Cord
1.	Power Supply	GWINSTEK	PSS-2002	N/A	N/A	Unshielded, 1.8 m
2.	LTE Base Station	Anritsu	MT8820C	N/A	N/A	Unshielded, 1.8 m
3.	NR Base Station	Anritsu	MT8000A	N/A	N/A	Unshielded, 1.8 m

## 2.4 Measurement Results Explanation Example

### For all conducted test items:

The offset level is set in the spectrum analyzer to compensate the RF cable loss between EUT conducted output port and spectrum analyzer. With the offset compensation, the spectrum analyzer reading level is exactly the EUT RF output level.

The spectrum analyzer offset is derived from RF cable loss.

$Offset = RF\ cable\ loss.$

Following shows an offset computation example with cable loss 8.70 dB.

Example :

$Offset(dB) = RF\ cable\ loss(dB).$

$= 8.70\ (dB)$

## 2.5 Frequency List of Low/Middle/High Channels

5G n77/n78 Channel and Frequency List for SCS 15kHz				
BW [MHz]	Channel/Frequency(MHz)	Lowest	Middle	Highest
50	Channel	631667	633334	635000
	Frequency	3475.005	3500.01	3525
40	Channel	631334	633334	635333
	Frequency	3470.01	3500.01	3529.995
30	Channel	631000	633334	635666
	Frequency	3465	3500.01	3534.99
25	Channel	630834	633334	635833
	Frequency	3462.51	3500.01	3537.495
20	Channel	630667	633334	636000
	Frequency	3460.005	3500.01	3540
15	Channel	630500	633334	636166
	Frequency	3457.5	3500.01	3542.49
10	Channel	630334	633334	636333
	Frequency	3455.01	3500.01	3544.995



5G n77/n78 Channel and Frequency List for SCS 30kHz				
BW [MHz]	Channel/Frequency(MHz)	Lowest	Middle	Highest
100	Channel	-	633334	-
	Frequency	-	3500.01	-
90	Channel	633000	633334	633666
	Frequency	3495	3500.01	3504.99
80	Channel	632668	633334	634000
	Frequency	3490.02	3500.01	3510
70	Channel	632334	633334	634332
	Frequency	3485.01	3500.01	3514.98
60	Channel	632000	633334	634666
	Frequency	3480	3500.01	3519.99
50	Channel	631668	633334	635000
	Frequency	3475.02	3500.01	3525
40	Channel	631334	633334	635332
	Frequency	3470.01	3500.01	3529.98
30	Channel	631000	633334	635666
	Frequency	3465	3500.01	3534.99
25	Channel	630834	633334	635832
	Frequency	3462.51	3500.01	3537.48
20	Channel	630668	633334	636000
	Frequency	3460.02	3500.01	3540
15	Channel	630500	633334	636166
	Frequency	3457.5	3500.01	3542.49
10	Channel	630334	633334	636332
	Frequency	3455.01	3500.01	3544.98

### 3 Conducted Test Items

#### 3.1 Measuring Instruments

See list of measuring instruments of this test report.

#### 3.2 Test Setup

##### 3.2.1 Conducted Output Power

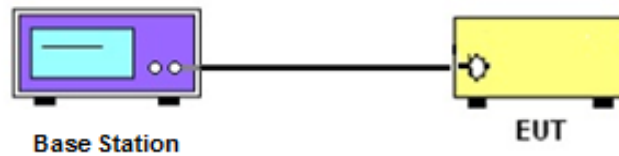

##### 3.2.2 Peak-to-Average Ratio, Occupied / 26dB Bandwidth, Band-Edge and Conducted Spurious Emission

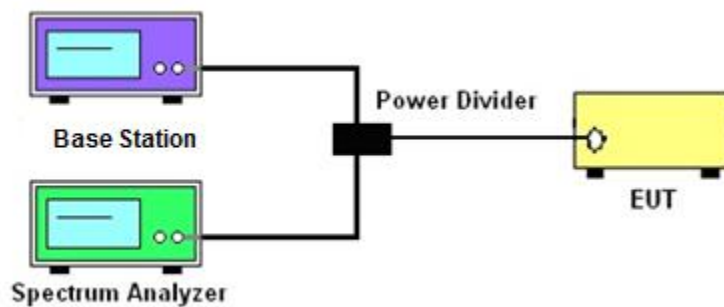

##### 3.2.3 Frequency Stability

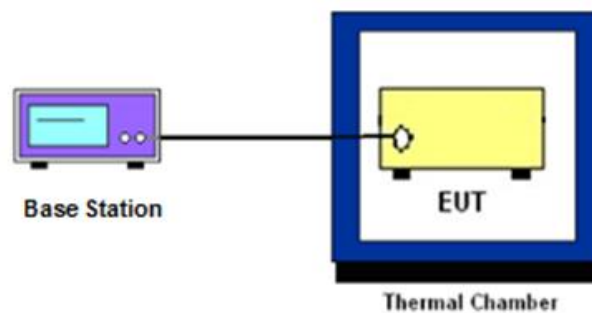

### 3.3 Test Result of Conducted Test

Please refer to Appendix A.



## **3.4 Conducted Output Power Measurement**

### **3.4.1 Description of the Conducted Output Power Measurement**

A base station simulator was used to establish communication with the EUT. Its parameters were set to transmit the maximum power on the EUT. The measured power in the radio frequency on the transmitter output terminals shall be reported.

### **3.4.2 Test Procedures**

1. The testing follows ANSI C63.26 Section 5.2
2. The transmitter output port was connected to the system simulator.
3. Set EUT at maximum power through the system simulator.
4. Select lowest, middle, and highest channels for each band and different modulation.
5. Measure and record the power level from the system simulator.

## 3.5 Peak-to-Average Ratio

### 3.5.1 Description of the PAR Measurement

Power Complementary Cumulative Distribution Function (CCDF) curves provide a means for characterizing the power peaks of a digitally modulated signal on a statistical basis. A CCDF curve depicts the probability of the peak signal amplitude exceeding the average power level. Most contemporary measurement instrumentation include the capability to produce CCDF curves for an input signal provided that the instrument's resolution bandwidth can be set wide enough to accommodate the entire input signal bandwidth. In measuring transmissions in this band using an average power technique, the peak-to-average ratio (PAR) of the transmission may not exceed 13 dB.

### 3.5.2 Test Procedures

1. The testing follows ANSI C63.26 Section 5.2.3.4 (CCDF).
2. The EUT was connected to spectrum and system simulator via a power divider.
3. Set the CCDF (Complementary Cumulative Distribution Function) option in spectrum analyzer.
4. The highest RF powers were measured and recorded the maximum PAPR level associated with a probability of 0.1 %.
5. Record the deviation as Peak to Average Ratio.

## 3.6 EIRP

### 3.6.1 Description of EIRP Limit

#### § 27.50 (k)(3)

Mobile devices are limited to 1Watt (30 dBm) EIRP. Mobile devices operating in these bands must employ a means for limiting power to the minimum necessary for successful communications.

### 3.6.2 Test Procedures

1. According to KDB 412172 D01 Power Approach,
2.  $EIRP = P_T + G_T - L_C$ ,  $ERP = EIRP - 2.15$ , where  
 $P_T$  = transmitter output power in dBm  
 $G_T$  = gain of the transmitting antenna in dBi  
 $L_C$  = signal attenuation in the connecting cable between the transmitter and antenna in dB

## 3.7 Occupied Bandwidth

### 3.7.1 Description of Occupied Bandwidth Measurement

The occupied bandwidth is the width of a frequency band such that, below the lower and above the upper frequency limits, the mean powers emitted are each equal to a specified percentage 0.5% of the total mean transmitted power.

The 26 dB emission bandwidth is defined as the frequency range between two points, one above and one below the carrier frequency, at which the spectral density of the emission is attenuated 26 dB below the maximum in-band spectral density of the modulated signal. Spectral density (power per unit bandwidth) is to be measured with a detector of resolution bandwidth equal to approximately 1.0% of the emission bandwidth.

### 3.7.2 Test Procedures

1. The testing follows ANSI C63.26 Section 5.4
2. The EUT was connected to spectrum analyzer and system simulator via a power divider.
3. The spectrum analyzer center frequency is set to the nominal EUT channel center frequency. The span range for the spectrum analyzer shall be between two and five times the anticipated OBW.
4. The nominal resolution bandwidth (RBW) shall be in the range of 1 to 5 % of the anticipated OBW, and the VBW shall be at least 3 times the RBW.
5. Set the detection mode to peak, and the trace mode to max hold.
6. Determine the reference value: Set the EUT to transmit a modulated signal. Allow the trace to stabilize. Set the spectrum analyzer marker to the highest level of the displayed trace.  
(this is the reference value)
7. Determine the “-26 dB down amplitude” as equal to (Reference Value – X).
8. Place two markers, one at the lowest and the other at the highest frequency of the envelope of the spectral display such that each marker is at or slightly below the “-X dB down amplitude” determined in step 6. If a marker is below this “-X dB down amplitude” value it shall be placed as close as possible to this value. The OBW is the positive frequency difference between the two markers.
9. Use the 99 % power bandwidth function of the spectrum analyzer and report the measured bandwidth.

## 3.8 Conducted Band Edge Measurement

### 3.8.1 Description of Conducted Band Edge Measurement

#### § 27.53 (n)(2)

For mobile operations in the 3450-3550 MHz band, the conducted power of any emission outside the licensee's authorized bandwidth shall not exceed  $-13$  dBm/MHz.

Compliance with this paragraph is based on the use of measurement instrumentation employing a resolution bandwidth of 1 megahertz or greater. However, in the 1 megahertz bands immediately outside and adjacent to the licensee's frequency block, a resolution bandwidth of at least one percent of the emission bandwidth of the fundamental emission of the transmitter may be employed, but limited to a maximum of 200 kHz. In the bands between 1 and 5 MHz removed from the licensee's frequency block, the minimum resolution bandwidth for the measurement shall be 500 kHz.

### 3.8.2 Test Procedures

1. The testing follows ANSI C63.26 section 5.7
2. The EUT was connected to spectrum analyzer and system simulator via a power divider.
3. The band edges of low and high channels for the highest RF powers were measured.
4. Set RBW  $\geq$  1% EBW but limited to a maximum of 200 kHz in the 1MHz band immediately outside and adjacent to the band edge.
5. Beyond the 1 MHz and 5 MHz removed from the band edge, set RBW  $\geq$  500KHz.
6. Beyond the 5 MHz removed from the band edge, set RBW = 1MHz.
7. Set spectrum analyzer with RMS detector.
8. The RF fundamental frequency should be excluded against the limit line in the operating frequency band.
9. Checked that all the results comply with the emission limit line.

## 3.9 Conducted Spurious Emission Measurement

### 3.9.1 Description of Conducted Spurious Emission Measurement

The power of any emission outside of the authorized operating frequency ranges shall not exceed -13 dBm/MHz.

It is measured by means of a calibrated spectrum analyzer and scanned from 9 kHz up to a frequency including its 10<sup>th</sup> harmonic.

### 3.9.2 Test Procedures

1. The testing follows ANSI C63.26 section 5.7
2. The EUT was connected to spectrum analyzer and system simulator via a power divider.
3. The RF output of EUT was connected to the spectrum analyzer by RF cable and attenuator. The path loss was compensated to the results for each measurement.
4. The middle channel for the highest RF power within the transmitting frequency was measured.
5. The conducted spurious emission for the whole frequency range was taken.
6. Make the measurement with the spectrum analyzer's RBW = 1MHz, VBW = 3MHz.
7. Set spectrum analyzer with RMS detector.
8. Taking the record of maximum spurious emission.
9. The RF fundamental frequency should be excluded against the limit line in the operating frequency band.
10. Checked that all the results comply with the emission limit line.

## 3.10 Frequency Stability Measurement

### 3.10.1 Description of Frequency Stability Measurement

The frequency stability shall be measured by variation of ambient temperature and variation of primary supply voltage to ensure that the fundamental emission stays within the authorized frequency block.

### 3.10.2 Test Procedures for Temperature Variation

1. The testing follows ANSI C63.26 section 5.6.4
2. The EUT was set up in the thermal chamber and connected with the system simulator.
3. With power OFF, the temperature was decreased to -30°C and the EUT was stabilized before testing. Power was applied and the maximum change in frequency was recorded within one minute.
4. With power OFF, the temperature was raised in 10°C step up to 50°C. The EUT was stabilized at each step for at least half an hour. Power was applied and the maximum frequency change was recorded within one minute.

### 3.10.3 Test Procedures for Voltage Variation

1. The testing follows ANSI C63.26 section 5.6.5.
2. The EUT was placed in a temperature chamber at 20±5°C and connected with the system simulator.
3. The power supply voltage to the EUT was varied from 85% to 115% of the nominal value for other than hand carried battery equipment.
4. For hand carried, battery powered equipment, reduce the primary ac or dc supply voltage to the battery operating end point, which shall be specified by the manufacturer.
5. The variation in frequency was measured for the worst case.

## 4 Radiated Test Items

### 4.1 Measuring Instruments

See list of measuring instruments of this test report.

### 4.2 Test Setup

#### 4.2.1 For radiated test below 30MHz

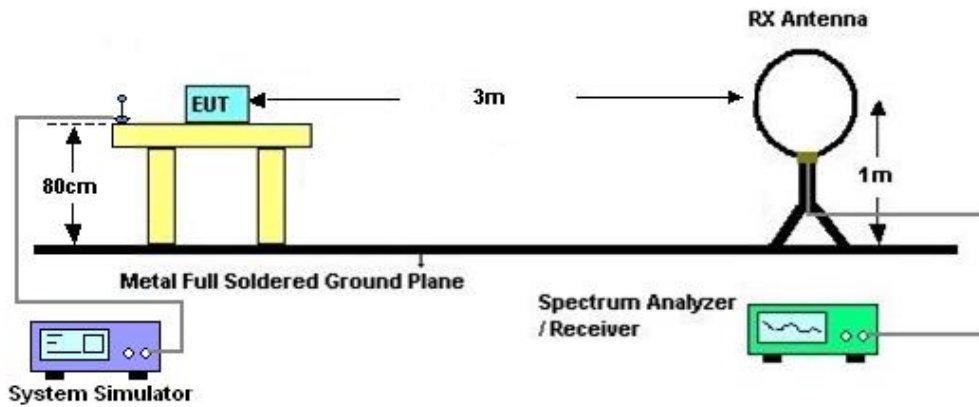

#### 4.2.2 For radiated test from 30MHz to 1GHz

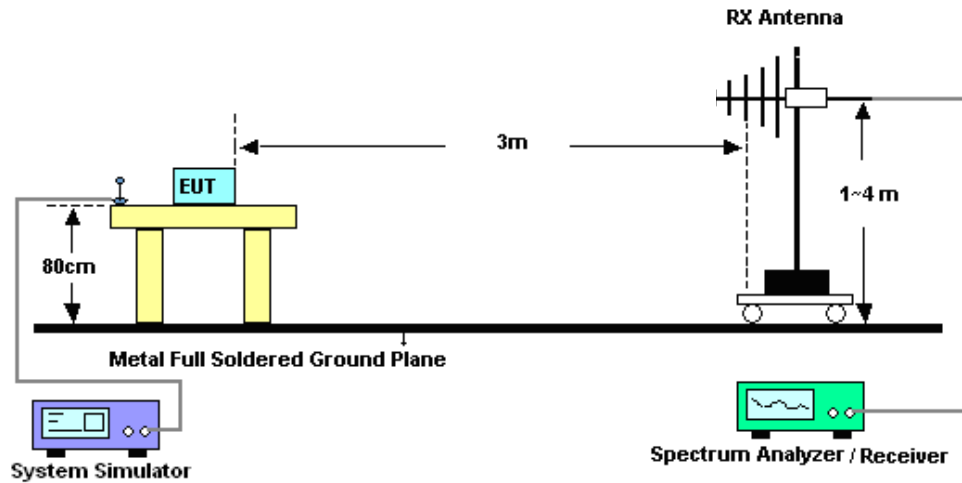

### 4.2.3 For radiated test above 1GHz

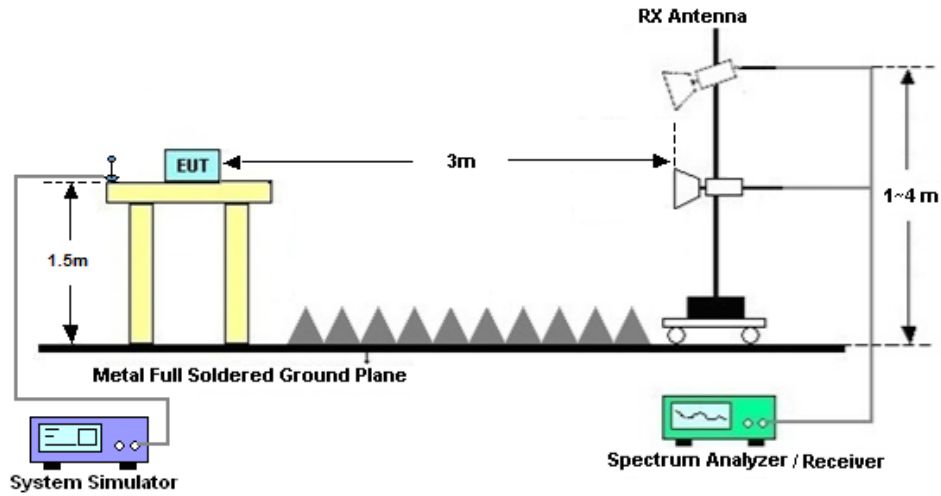

## 4.3 Test Result of Radiated Test

The low frequency, which started from 9 kHz to 30MHz, was pre-scanned and the result which was 20dB lower than the limit line was not reported.

Please refer to Appendix B.

## 4.4 Radiated Spurious Emission Measurement

### 4.4.1 Description of Radiated Spurious Emission

The radiated spurious emission was measured by substitution method according to ANSI/TIA-603-E. The power of any emission outside of the authorized operating frequency ranges shall not exceed -13 dBm/MHz.

The spectrum is scanned from 30 MHz up to a frequency including its 10th harmonic.

### 4.4.2 Test Procedures

1. The testing follows ANSI C63.26 Section 5.5
2. The EUT was placed on a turntable with 0.8 meter height for frequency below 1GHz and 1.5 meter height for frequency above 1GHz respectively above ground.
3. The EUT was set 3 meters from the receiving antenna mounted on the antenna tower.
4. The table was rotated 360 degrees to determine the position of the highest spurious emission.
5. The height of the receiving antenna is varied between 1m to 4m to search the maximum spurious emission for both horizontal and vertical polarizations.
6. During the measurement, the system simulator parameters were set to force the EUT transmitting at maximum output power.
7. Make the measurement with the spectrum analyzer's RBW = 1MHz, VBW = 3MHz, taking the record of maximum spurious emission.
8. A horn antenna was substituted in place of the EUT and was driven by a signal generator.
9. Tune the output power of signal generator to the same emission level with EUT maximum spurious emission.  
$$\text{EIRP (dBm)} = \text{S.G. Power} - \text{Tx Cable Loss} + \text{Tx Antenna Gain}$$
$$\text{ERP (dBm)} = \text{EIRP} - 2.15$$
10. The RF fundamental frequency should be excluded against the limit line in the operating frequency band.



## 5 List of Measuring Equipment

Instrument	Manufacturer	Model No.	Serial No.	Characteristics	Calibration Date	Test Date	Due Date	Remark
Spectrum Analyzer	R&S	FSV40	101078	10Hz~40GHz	Apr. 07, 2022	Mar. 10, 2023~ Apr. 14, 2023	Apr. 08, 2023	Conducted (TH01-SZ)
Spectrum Analyzer	R&S	FSV40	101078	10Hz~40GHz	Apr. 08, 2023		Apr. 07, 2024	Conducted (TH01-SZ)
Power Divider	TOJOIN	PS-2SM-04 265	60.06.020.0077	0.4GHz~26.5GHz	Dec. 25, 2022	Mar. 10, 2023~ Apr. 14, 2023	Dec. 24, 2023	Conducted (TH01-SZ)
Thermal Chamber	Ten Billion Hongzhangroup	LP-150U	H2014081803	-40~+150°C	Jul. 07, 2022	Mar. 10, 2023~ Apr. 14, 2023	Jul. 06, 2023	Conducted (TH01-SZ)
EXA Spectrum Analyzer	Keysight	N9010B	MY57471079	10Hz-44G,MAX 30dB	Oct. 12, 2022	Mar. 30, 2023	Oct. 11, 2023	Radiation (03CH04-KS)
Loop Antenna	R&S	HFH2-Z2	100321	9kHz~30MHz	Oct. 29, 2022	Mar. 30, 2023	Oct. 28, 2023	Radiation (03CH04-KS)
Bilog Antenna	TeseQ	CBL6111D	49922	30MHz-1GHz	May 24, 2022	Mar. 30, 2023	May 23, 2023	Radiation (03CH04-KS)
Horn Antenna	Schwarzbeck	BBHA9120D	1284	1GHz~18GHz	Oct. 16, 2022	Mar. 30, 2023	Oct. 15, 2023	Radiation (03CH04-KS)
SHF-EHF Horn	Com-power	AH-840	101070	18GHz~40GHz	Jan. 08, 2023	Mar. 30, 2023	Jan. 07, 2024	Radiation (03CH04-KS)
Amplifier	SONOMA	310N	187289	9KHz-1GHz	May 24, 2022	Mar. 30, 2023	May 23, 2023	Radiation (03CH04-KS)
Amplifier	MITEQ	EM18G40G GA	060728	18~40GHz	Jan. 05, 2023	Mar. 30, 2023	Jan. 04, 2024	Radiation (03CH04-KS)
high gain Amplifier	EM	EM01G18G A	060840	1Ghz-18Ghz	Oct. 12, 2022	Mar. 30, 2023	Oct. 11, 2023	Radiation (03CH04-KS)
Amplifier	Agilent	8449B	3008A02370	1Ghz-18Ghz	Oct. 12, 2022	Mar. 30, 2023	Oct. 11, 2023	Radiation (03CH04-KS)
AC Power Source	Chroma	61601	F104090004	N/A	NCR	Mar. 30, 2023	NCR	Radiation (03CH04-KS)
Turn Table	ChamPro	EM 1000-T	060762-T	0~360 degree	NCR	Mar. 30, 2023	NCR	Radiation (03CH04-KS)
Antenna Mast	ChamPro	EM 1000-A	060762-A	1 m~4 m	NCR	Mar. 30, 2023	NCR	Radiation (03CH04-KS)

NCR: No Calibration Required

## 6 Uncertainty of Evaluation

The measurement uncertainties shown below were calculated in accordance with the requirements of ANSI 63.26-2015. All the measurement uncertainty value were shown with a coverage K=2 to indicate 95% level of confidence. The measurement data show herein meets or exceeds the CISPR measurement uncertainty values specified in CISPR 16-4-2 and can be compared directly to specified limit to determine compliance.

### Uncertainty of Conducted Measurement

Test Item	Uncertainty
Conducted Power	±1.34 dB
Conducted Emissions	±1.34 dB
Occupied Channel Bandwidth	±0.13 %

### Uncertainty of Radiated Emission Measurement (30 MHz ~ 1000 MHz)

Measuring Uncertainty for a Level of Confidence of 95% (U = 2Uc(y))	3.3dB
---	-------

### Uncertainty of Radiated Emission Measurement (1 GHz ~ 18 GHz)

Measuring Uncertainty for a Level of Confidence of 95% (U = 2Uc(y))	2.8dB
---	-------

### Uncertainty of Radiated Emission Measurement (18 GHz ~ 40 GHz)

Measuring Uncertainty for a Level of Confidence of 95% (U = 2Uc(y))	2.8dB
---	-------

----- THE END -----



## Appendix A. Test Results of Conducted Test

Test Engineer :	Jung Guo	Temperature :	22~23°C
		Relative Humidity :	40~42%

## FR1 N77(ANT4) – SCS 15k

### Transmitter Conducted Output Power And EIRP, ( $G_T - L_C$ )=-8.8dB

NR Band	SCS (kHz)	Bandwidth (MHz)	Arfcn	Freq (MHz)	Modulation	RB	Conducted Power (dBm)	EIRP (dBm)	EIRP (W)
77	15	10	630334	3455.01	DFT-s-OFDM QPSK	1@1	25.8	17	0.0501
77	15	10	630334	3455.01	DFT-s-OFDM 16 QAM	1@1	25.03	16.23	0.0420
77	15	10	633334	3500.01	DFT-s-OFDM QPSK	1@1	26.15	17.35	0.0543
77	15	10	633334	3500.01	DFT-s-OFDM 16 QAM	1@1	25.23	16.43	0.0440
77	15	10	636333	3544.995	DFT-s-OFDM QPSK	1@1	25.86	17.06	0.0508
77	15	10	636333	3544.995	DFT-s-OFDM 16 QAM	1@1	24.92	16.12	0.0409
77	15	15	630500	3457.5	DFT-s-OFDM QPSK	1@1	25.88	17.08	0.0511
77	15	15	630500	3457.5	DFT-s-OFDM 16 QAM	1@1	25.09	16.29	0.0426
77	15	15	633334	3500.01	DFT-s-OFDM QPSK	1@1	26.2	17.4	0.0550
77	15	15	633334	3500.01	DFT-s-OFDM 16 QAM	1@1	25.31	16.51	0.0448
77	15	15	636166	3542.49	DFT-s-OFDM QPSK	1@1	25.98	17.18	0.0522
77	15	15	636166	3542.49	DFT-s-OFDM 16 QAM	1@1	25.11	16.31	0.0428
77	15	20	630667	3460.005	DFT-s-OFDM QPSK	1@1	25.89	17.09	0.0512
77	15	20	630667	3460.005	DFT-s-OFDM 16 QAM	1@1	25.08	16.28	0.0425
77	15	20	633334	3500.01	DFT-s-OFDM QPSK	1@1	26.18	17.38	0.0547
77	15	20	633334	3500.01	DFT-s-OFDM 16 QAM	1@1	25.35	16.55	0.0452
77	15	20	636000	3540	DFT-s-OFDM QPSK	1@1	25.88	17.08	0.0511
77	15	20	636000	3540	DFT-s-OFDM 16 QAM	1@1	25.17	16.37	0.0434
77	15	25	630834	3462.51	DFT-s-OFDM QPSK	1@1	25.86	17.06	0.0508
77	15	25	630834	3462.51	DFT-s-OFDM 16 QAM	1@1	25.17	16.37	0.0434
77	15	25	633334	3500.01	DFT-s-OFDM QPSK	1@1	26.24	17.44	0.0555
77	15	25	633334	3500.01	DFT-s-OFDM 16 QAM	1@1	25.45	16.65	0.0462
77	15	25	635833	3537.495	DFT-s-OFDM QPSK	1@1	25.95	17.15	0.0519
77	15	25	635833	3537.495	DFT-s-OFDM 16 QAM	1@1	25.22	16.42	0.0439
77	15	30	631000	3465	DFT-s-OFDM QPSK	1@1	25.88	17.08	0.0511
77	15	30	631000	3465	DFT-s-OFDM 16 QAM	1@1	25.11	16.31	0.0428
77	15	30	633334	3500.01	DFT-s-OFDM QPSK	1@1	26.19	17.39	0.0548
77	15	30	633334	3500.01	DFT-s-OFDM 16 QAM	1@1	25.42	16.62	0.0459
77	15	30	635666	3534.99	DFT-s-OFDM QPSK	1@1	26.06	17.26	0.0532
77	15	30	635666	3534.99	DFT-s-OFDM 16 QAM	1@1	25.22	16.42	0.0439
77	15	40	631334	3470.01	DFT-s-OFDM QPSK	1@1	25.88	17.08	0.0511
77	15	40	631334	3470.01	DFT-s-OFDM 16 QAM	1@1	25.12	16.32	0.0429
77	15	40	633334	3500.01	DFT-s-OFDM QPSK	1@1	26.16	17.36	0.0545
77	15	40	633334	3500.01	DFT-s-OFDM 16 QAM	1@1	25.35	16.55	0.0452

77	15	40	635333	3529.995	DFT-s-OFDM QPSK	1@1	26.13	17.33	0.0541
77	15	40	635333	3529.995	DFT-s-OFDM 16 QAM	1@1	25.35	16.55	0.0452
77	15	50	631667	3475.005	DFT-s-OFDM PI/2 BPSK	135@67	26.07	17.27	0.0533
77	15	50	631667	3475.005	DFT-s-OFDM PI/2 BPSK	1@1	25.95	17.15	0.0519
77	15	50	631667	3475.005	DFT-s-OFDM PI/2 BPSK	1@268	26.01	17.21	0.0526
77	15	50	631667	3475.005	DFT-s-OFDM QPSK	135@67	26.1	17.3	0.0537
77	15	50	631667	3475.005	DFT-s-OFDM QPSK	1@1	25.9	17.1	0.0513
77	15	50	631667	3475.005	DFT-s-OFDM QPSK	1@268	26.05	17.25	0.0531
77	15	50	631667	3475.005	DFT-s-OFDM 16 QAM	135@67	25.15	16.35	0.0432
77	15	50	631667	3475.005	DFT-s-OFDM 16 QAM	1@1	25.15	16.35	0.0432
77	15	50	631667	3475.005	DFT-s-OFDM 16 QAM	1@268	25.21	16.41	0.0438
77	15	50	631667	3475.005	DFT-s-OFDM 64 QAM	135@67	23.61	14.81	0.0303
77	15	50	631667	3475.005	DFT-s-OFDM 64 QAM	1@1	23.44	14.64	0.0291
77	15	50	631667	3475.005	DFT-s-OFDM 64 QAM	1@268	23.66	14.86	0.0306
77	15	50	631667	3475.005	DFT-s-OFDM 256 QAM	135@67	21.62	12.82	0.0191
77	15	50	631667	3475.005	DFT-s-OFDM 256 QAM	1@1	21.55	12.75	0.0188
77	15	50	631667	3475.005	DFT-s-OFDM 256 QAM	1@268	21.67	12.87	0.0194
77	15	50	631667	3475.005	CP-OFDM QPSK	135@67	24.57	15.77	0.0378
77	15	50	631667	3475.005	CP-OFDM QPSK	1@1	24.36	15.56	0.0360
77	15	50	631667	3475.005	CP-OFDM QPSK	1@268	24.52	15.72	0.0373
77	15	50	633334	3500.01	DFT-s-OFDM PI/2 BPSK	135@67	26.19	17.39	0.0548
77	15	50	633334	3500.01	DFT-s-OFDM PI/2 BPSK	1@1	26.1	17.3	0.0537
77	15	50	633334	3500.01	DFT-s-OFDM PI/2 BPSK	1@268	26.06	17.26	0.0532
77	15	50	633334	3500.01	DFT-s-OFDM QPSK	135@67	26.25	17.45	0.0556
77	15	50	633334	3500.01	DFT-s-OFDM QPSK	1@1	26.12	17.32	0.0540
77	15	50	633334	3500.01	DFT-s-OFDM QPSK	1@268	25.85	17.05	0.0507
77	15	50	633334	3500.01	DFT-s-OFDM 16 QAM	135@67	25.2	16.4	0.0437
77	15	50	633334	3500.01	DFT-s-OFDM 16 QAM	1@1	25.32	16.52	0.0449
77	15	50	633334	3500.01	DFT-s-OFDM 16 QAM	1@268	25.1	16.3	0.0427
77	15	50	633334	3500.01	DFT-s-OFDM 64 QAM	135@67	23.73	14.93	0.0311
77	15	50	633334	3500.01	DFT-s-OFDM 64 QAM	1@1	23.65	14.85	0.0305
77	15	50	633334	3500.01	DFT-s-OFDM 64 QAM	1@268	23.43	14.63	0.0290
77	15	50	633334	3500.01	DFT-s-OFDM 256 QAM	135@67	21.73	12.93	0.0196
77	15	50	633334	3500.01	DFT-s-OFDM 256 QAM	1@1	21.75	12.95	0.0197
77	15	50	633334	3500.01	DFT-s-OFDM 256 QAM	1@268	21.49	12.69	0.0186
77	15	50	633334	3500.01	CP-OFDM QPSK	135@67	24.6	15.8	0.0380
77	15	50	633334	3500.01	CP-OFDM QPSK	1@1	24.59	15.79	0.0379
77	15	50	633334	3500.01	CP-OFDM QPSK	1@268	24.49	15.69	0.0371
77	15	50	635000	3525	DFT-s-OFDM PI/2 BPSK	135@67	26.01	17.21	0.0526
77	15	50	635000	3525	DFT-s-OFDM PI/2 BPSK	1@1	26.22	17.42	0.0552
77	15	50	635000	3525	DFT-s-OFDM PI/2 BPSK	1@268	26.04	17.24	0.0530
77	15	50	635000	3525	DFT-s-OFDM QPSK	135@67	25.94	17.14	0.0518

77	15	50	635000	3525	DFT-s-OFDM QPSK	1@1	26.21	17.41	0.0551
77	15	50	635000	3525	DFT-s-OFDM QPSK	1@268	25.8	17	0.0501
77	15	50	635000	3525	DFT-s-OFDM 16 QAM	135@67	24.98	16.18	0.0415
77	15	50	635000	3525	DFT-s-OFDM 16 QAM	1@1	25.45	16.65	0.0462
77	15	50	635000	3525	DFT-s-OFDM 16 QAM	1@268	25	16.2	0.0417
77	15	50	635000	3525	DFT-s-OFDM 64 QAM	135@67	23.53	14.73	0.0297
77	15	50	635000	3525	DFT-s-OFDM 64 QAM	1@1	23.72	14.92	0.0310
77	15	50	635000	3525	DFT-s-OFDM 64 QAM	1@268	23.38	14.58	0.0287
77	15	50	635000	3525	DFT-s-OFDM 256 QAM	135@67	21.51	12.71	0.0187
77	15	50	635000	3525	DFT-s-OFDM 256 QAM	1@1	21.91	13.11	0.0205
77	15	50	635000	3525	DFT-s-OFDM 256 QAM	1@268	21.43	12.63	0.0183
77	15	50	635000	3525	CP-OFDM QPSK	135@67	24.49	15.69	0.0371
77	15	50	635000	3525	CP-OFDM QPSK	1@1	24.67	15.87	0.0386
77	15	50	635000	3525	CP-OFDM QPSK	1@268	24.4	15.6	0.0363

## Frequency Stability

NR Band	SCS (kHz)	Bandwidth (MHz)	Arfcn	Freq (MHz)	Modulation	RB	Deviation (ppm)	Verdict	Environment
77	15	20	633334	3500.01	DFT-s-OFDM QPSK	100@0	0.0050	PASS	NV
77	15	20	633334	3500.01	DFT-s-OFDM QPSK	100@0	0.0059	PASS	LV
77	15	20	633334	3500.01	DFT-s-OFDM QPSK	100@0	0.0056	PASS	HV
77	15	20	633334	3500.01	DFT-s-OFDM QPSK	100@0	0.0032	PASS	-30°C
77	15	20	633334	3500.01	DFT-s-OFDM QPSK	100@0	0.0026	PASS	-20°C
77	15	20	633334	3500.01	DFT-s-OFDM QPSK	100@0	0.0027	PASS	-10°C
77	15	20	633334	3500.01	DFT-s-OFDM QPSK	100@0	0.0052	PASS	0°C
77	15	20	633334	3500.01	DFT-s-OFDM QPSK	100@0	0.0055	PASS	10°C
77	15	20	633334	3500.01	DFT-s-OFDM QPSK	100@0	0.0050	PASS	20°C
77	15	20	633334	3500.01	DFT-s-OFDM QPSK	100@0	0.0033	PASS	30°C
77	15	20	633334	3500.01	DFT-s-OFDM QPSK	100@0	0.0040	PASS	40°C
77	15	20	633334	3500.01	DFT-s-OFDM QPSK	100@0	0.0044	PASS	50°C

## Peak to Average Ratio

NR Band	SCS (kHz)	Bandwidth (MHz)	Arfcn	Freq (MHz)	Modulation	RB	Result (dB)	Limit (dB)	Verdict
77	15	20	630667	3460.005	DFT-s-OFDM PI/2 BPSK	100@0	4.52	13	PASS
77	15	20	630667	3460.005	DFT-s-OFDM PI/2 BPSK	1@0	4.15	13	PASS
77	15	20	630667	3460.005	DFT-s-OFDM QPSK	100@0	5.67	13	PASS
77	15	20	630667	3460.005	DFT-s-OFDM QPSK	1@0	5.39	13	PASS
77	15	20	633334	3500.01	DFT-s-OFDM PI/2 BPSK	100@0	4.54	13	PASS
77	15	20	633334	3500.01	DFT-s-OFDM PI/2 BPSK	1@0	4.55	13	PASS
77	15	20	633334	3500.01	DFT-s-OFDM QPSK	100@0	5.65	13	PASS
77	15	20	633334	3500.01	DFT-s-OFDM QPSK	1@0	5.5	13	PASS
77	15	20	636000	3540.0	DFT-s-OFDM PI/2 BPSK	100@0	4.5	13	PASS
77	15	20	636000	3540.0	DFT-s-OFDM PI/2 BPSK	1@0	4.8	13	PASS
77	15	20	636000	3540.0	DFT-s-OFDM QPSK	100@0	5.64	13	PASS
77	15	20	636000	3540.0	DFT-s-OFDM QPSK	1@0	5.88	13	PASS

N77(20M)\_DFT-s-OFDM\_PI\_2-BPSK\_Outer\_Full\_Low\_CH



N77(20M)\_DFT-s-OFDM\_PI\_2-BPSK\_Edge\_1RB\_Left\_Low\_CH



N77(20M)\_DFT-s-OFDM\_QPSK\_Outer\_Full\_Low\_CH



N77(20M)\_DFT-s-OFDM\_QPSK\_Edge\_1RB\_Left\_Low\_CH

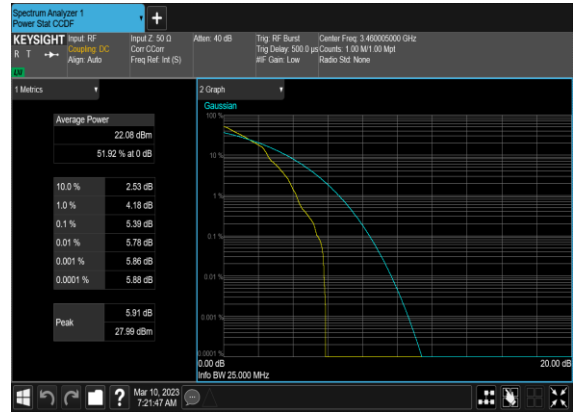

N77(20M)\_DFT-s-OFDM\_PI\_2-BPSK\_Outer\_Full\_Mid\_CH

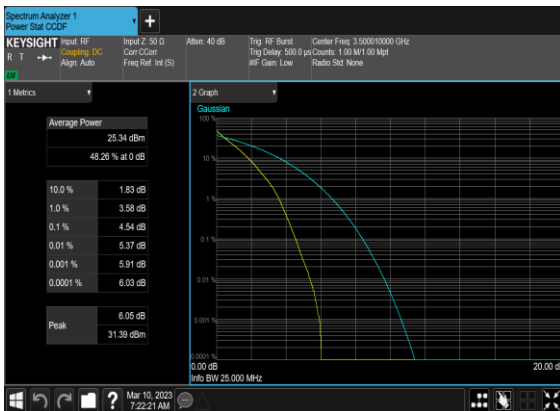

N77(20M)\_DFT-s-OFDM\_PI\_2-BPSK\_Edge\_1RB\_Left\_Mid\_CH

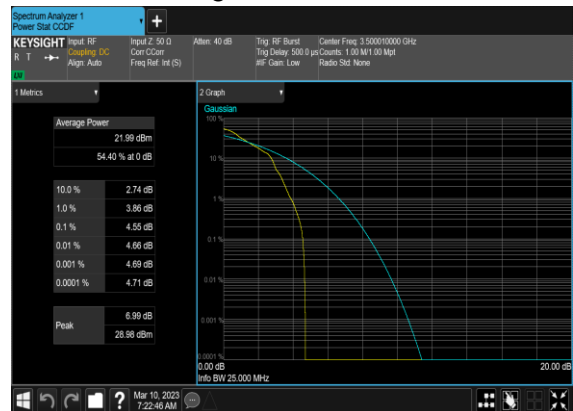

N77(20M)\_DFT-s-OFDM\_QPSK\_Outer\_Full\_Mid\_CH



N77(20M)\_DFT-s-OFDM\_QPSK\_Edge\_1RB\_Left\_Mid\_CH

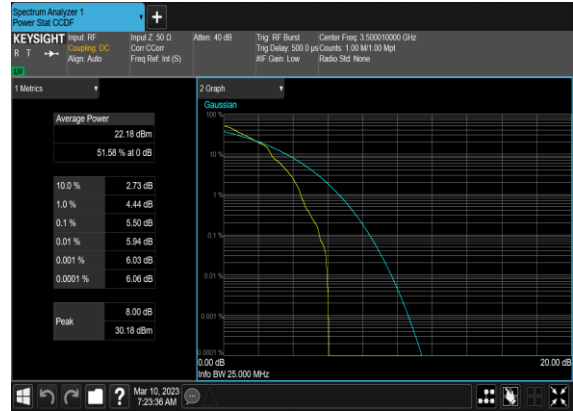

N77(20M)\_DFT-s-OFDM\_PI\_2-BPSK\_Outer\_Full\_High\_CH

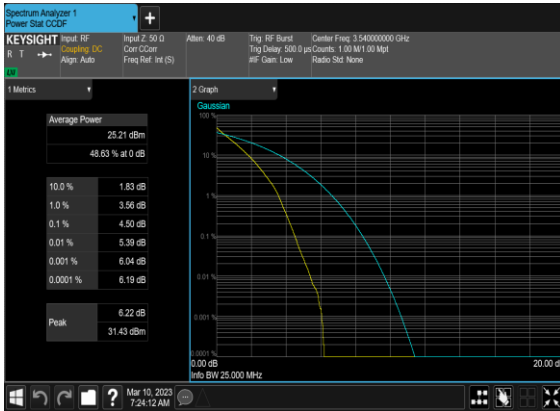

N77(20M)\_DFT-s-OFDM\_PI\_2-BPSK\_Edge\_1RB\_Left\_High\_CH

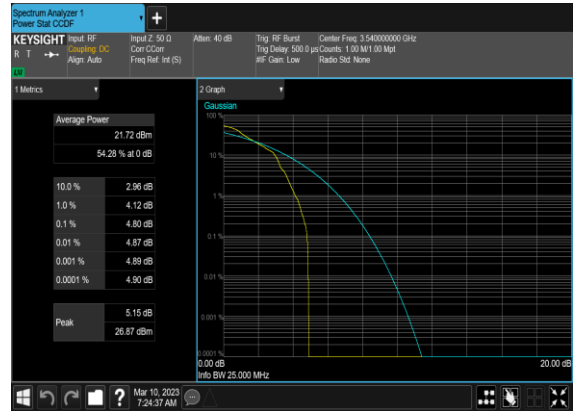

N77(20M)\_DFT-s-OFDM\_QPSK\_Outer\_Full\_High\_CH

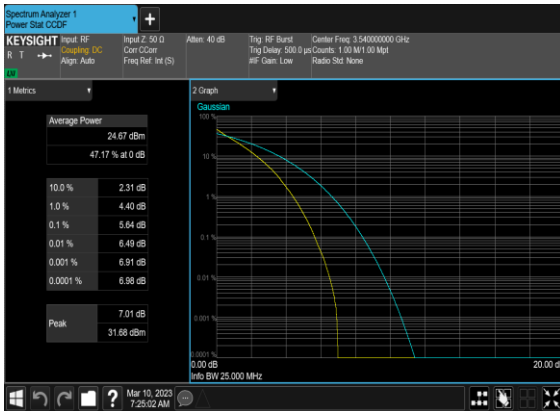

N77(20M)\_DFT-s-OFDM\_QPSK\_Edge\_1RB\_Left\_High\_CH

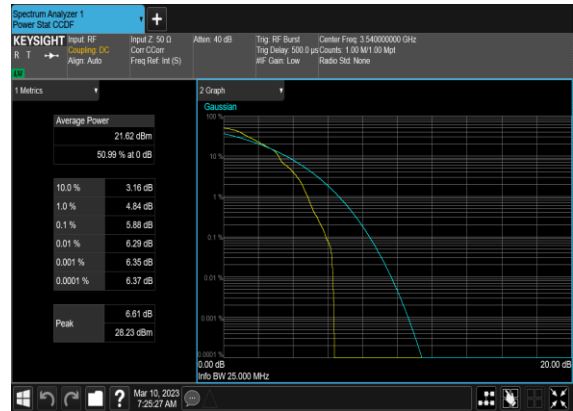

## Occupied Bandwidth

NR Band	SCS (kHz)	Bandwidth (MHz)	Arfcn	Freq (MHz)	Modulation	RB	OBW (MHz)	26dB BW (MHz)
77	15	10	633334	3500.01	DFT-s-OFDM PI/2 BPSK	50@0	8.9314	9.377
77	15	10	633334	3500.01	DFT-s-OFDM QPSK	50@0	8.9234	9.31
77	15	10	633334	3500.01	CP-OFDM QPSK	52@0	9.2657	9.645
77	15	10	633334	3500.01	CP-OFDM 16 QAM	52@0	9.275	9.658
77	15	10	633334	3500.01	CP-OFDM 64 QAM	52@0	9.265	9.628
77	15	10	633334	3500.01	CP-OFDM 256 QAM	52@0	9.2889	9.612
77	15	15	633334	3500.01	DFT-s-OFDM PI/2 BPSK	75@0	13.39	13.84
77	15	15	633334	3500.01	DFT-s-OFDM QPSK	75@0	13.348	13.87
77	15	15	633334	3500.01	CP-OFDM QPSK	79@0	14.102	14.66
77	15	15	633334	3500.01	CP-OFDM 16 QAM	79@0	14.091	14.61
77	15	15	633334	3500.01	CP-OFDM 64 QAM	79@0	14.058	14.58
77	15	15	633334	3500.01	CP-OFDM 256 QAM	79@0	14.109	14.72
77	15	20	633334	3500.01	DFT-s-OFDM PI/2 BPSK	100@0	17.876	18.57
77	15	20	633334	3500.01	DFT-s-OFDM QPSK	100@0	17.777	18.56
77	15	20	633334	3500.01	CP-OFDM QPSK	106@0	18.864	19.54
77	15	20	633334	3500.01	CP-OFDM 16 QAM	106@0	18.936	19.99
77	15	20	633334	3500.01	CP-OFDM 64 QAM	106@0	18.867	19.64
77	15	20	633334	3500.01	CP-OFDM 256 QAM	106@0	18.876	19.58
77	15	25	633334	3500.01	DFT-s-OFDM PI/2 BPSK	128@0	22.88	23.6
77	15	25	633334	3500.01	DFT-s-OFDM QPSK	128@0	22.903	23.66
77	15	25	633334	3500.01	CP-OFDM QPSK	133@0	23.779	24.52
77	15	25	633334	3500.01	CP-OFDM 16 QAM	133@0	23.704	24.45
77	15	25	633334	3500.01	CP-OFDM 64 QAM	133@0	23.728	24.5
77	15	25	633334	3500.01	CP-OFDM 256 QAM	133@0	23.652	24.51

77	15	30	633334	3500.01	DFT-s-OFDM PI/2 BPSK	160@0	28.643	29.55
77	15	30	633334	3500.01	DFT-s-OFDM QPSK	160@0	28.484	29.44
77	15	30	633334	3500.01	CP-OFDM QPSK	160@0	28.494	29.54
77	15	30	633334	3500.01	CP-OFDM 16 QAM	160@0	28.542	29.47
77	15	30	633334	3500.01	CP-OFDM 64 QAM	160@0	28.424	29.52
77	15	30	633334	3500.01	CP-OFDM 256 QAM	160@0	28.699	29.53
77	15	40	633334	3500.01	DFT-s-OFDM PI/2 BPSK	216@0	38.755	39.86
77	15	40	633334	3500.01	DFT-s-OFDM QPSK	216@0	38.538	39.8
77	15	40	633334	3500.01	CP-OFDM QPSK	216@0	38.379	39.84
77	15	40	633334	3500.01	CP-OFDM 16 QAM	216@0	38.497	39.94
77	15	40	633334	3500.01	CP-OFDM 64 QAM	216@0	38.575	40.08
77	15	40	633334	3500.01	CP-OFDM 256 QAM	216@0	38.523	39.81
77	15	50	633334	3500.01	DFT-s-OFDM PI/2 BPSK	270@0	48.246	49.74
77	15	50	633334	3500.01	DFT-s-OFDM QPSK	270@0	48.273	49.7
77	15	50	633334	3500.01	CP-OFDM QPSK	270@0	48.051	49.74
77	15	50	633334	3500.01	CP-OFDM 16 QAM	270@0	48.133	49.68
77	15	50	633334	3500.01	CP-OFDM 64 QAM	270@0	48.118	49.7
77	15	50	633334	3500.01	CP-OFDM 256 QAM	270@0	48.042	49.79

### N77(10M)\_DFT-s-OFDM\_PI\_2-BPSK\_Outer\_Full\_Mid\_CH

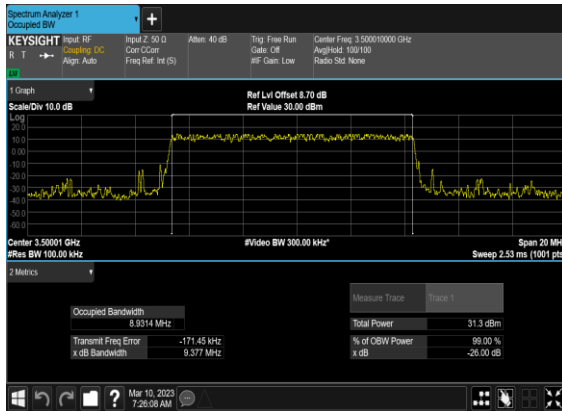

### N77(10M)\_DFT-s-OFDM\_QPSK\_Outer\_Full\_Mid\_CH

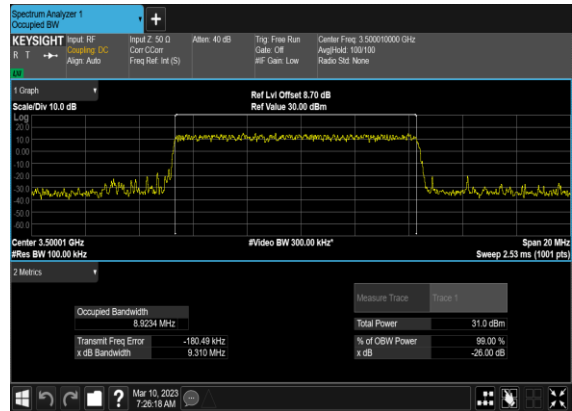

### N77(10M)\_CP-OFDM\_QPSK\_Outer\_Full\_Mid\_CH

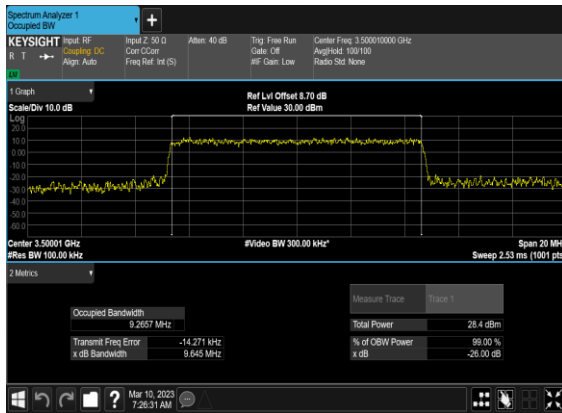

### N77(10M)\_CP-OFDM\_16QAM\_Outer\_Full\_Mid\_CH



### N77(10M)\_CP-OFDM\_64QAM\_Outer\_Full\_Mid\_CH

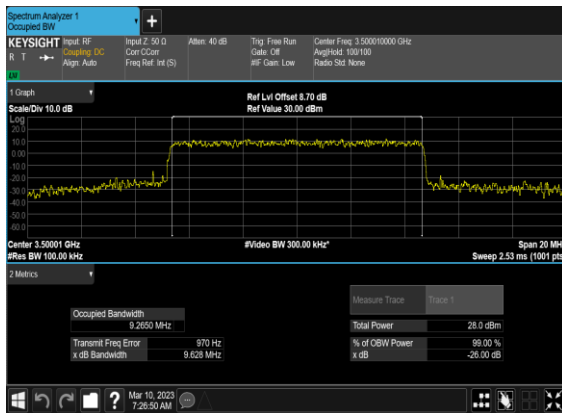

### N77(10M)\_CP-OFDM\_256QAM\_Outer\_Full\_Mid\_CH

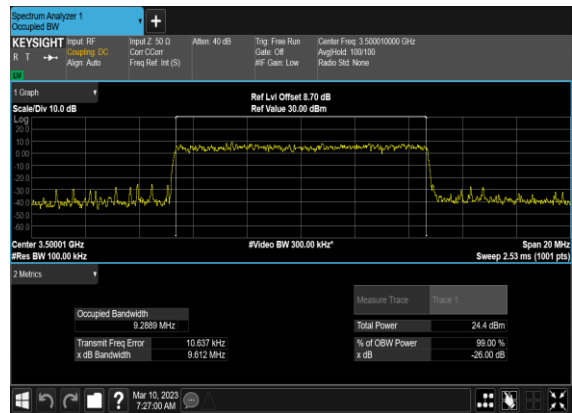

### N77(15M)\_DFT-s-OFDM\_PI\_2- BPSK\_Outer\_Full\_Mid\_CH

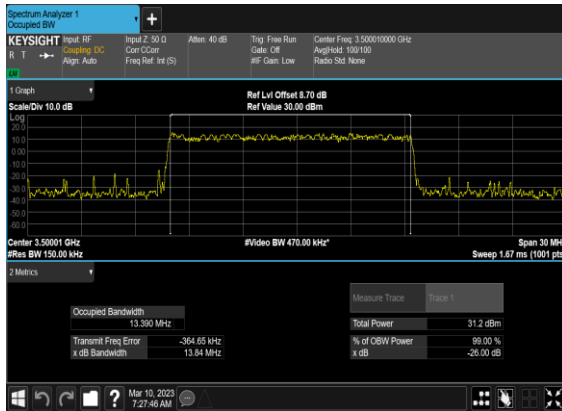

### N77(15M)\_DFT-s- OFDM\_QPSK\_Outer\_Full\_Mid\_CH

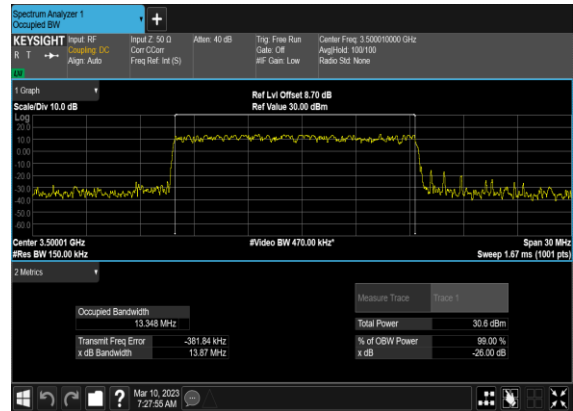

### N77(15M)\_CP- OFDM\_QPSK\_Outer\_Full\_Mid\_CH



### N77(15M)\_CP-OFDM\_16 QAM\_Outer\_Full\_Mid\_CH



### N77(15M)\_CP-OFDM\_64 QAM\_Outer\_Full\_Mid\_CH

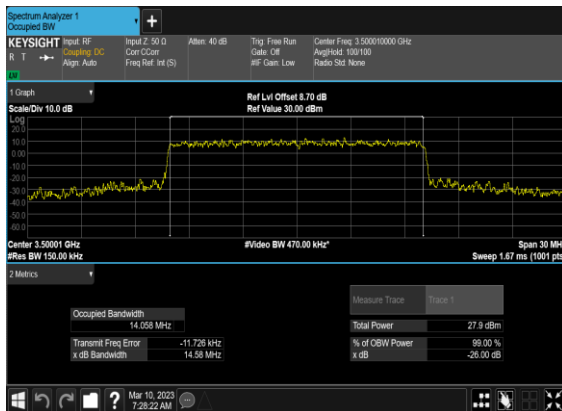

### N77(15M)\_CP-OFDM\_256 QAM\_Outer\_Full\_Mid\_CH

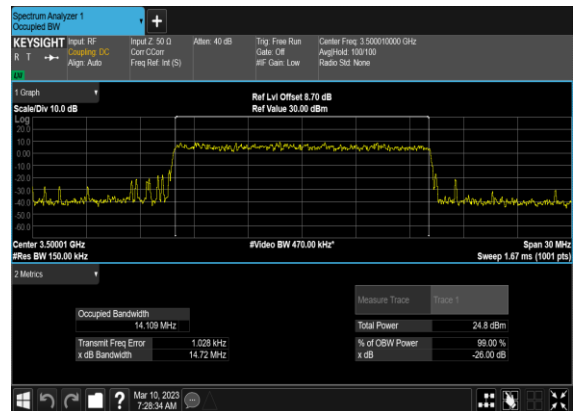

### N77(20M)\_DFT-s-OFDM\_PI\_2-BPSK\_Outer\_Full\_Mid\_CH

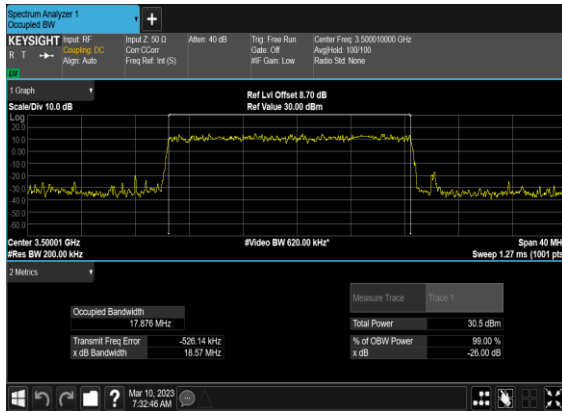

### N77(20M)\_DFT-s-OFDM\_QPSK\_Outer\_Full\_Mid\_CH

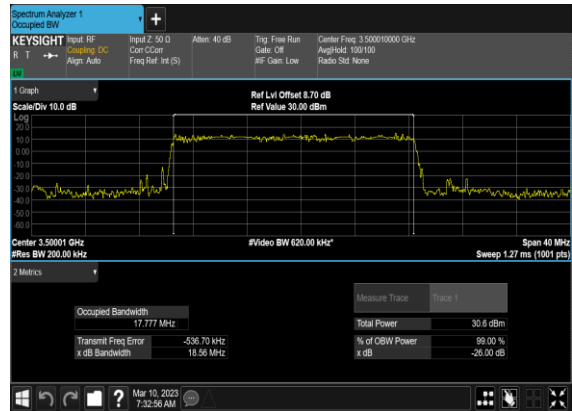

### N77(20M)\_CP-OFDM\_QPSK\_Outer\_Full\_Mid\_CH



### N77(20M)\_CP-OFDM\_16QAM\_Outer\_Full\_Mid\_CH

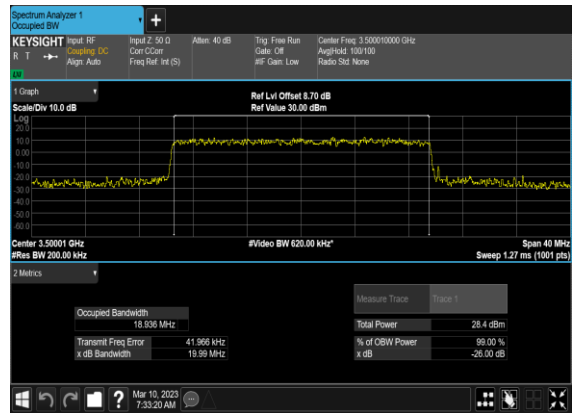

### N77(20M)\_CP-OFDM\_64QAM\_Outer\_Full\_Mid\_CH

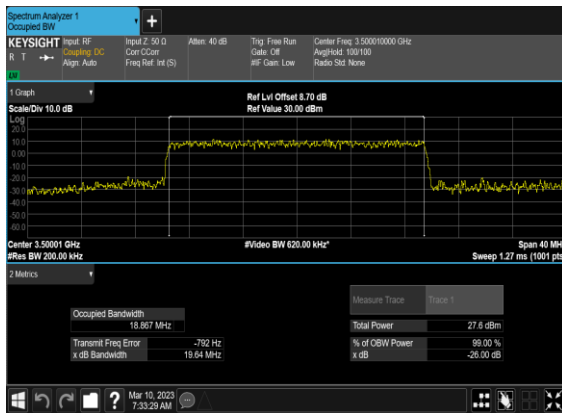

### N77(20M)\_CP-OFDM\_256QAM\_Outer\_Full\_Mid\_CH

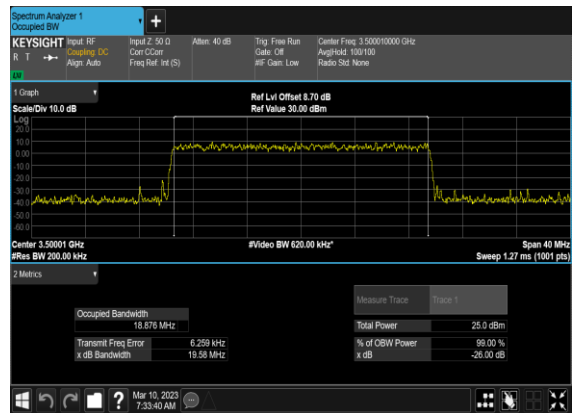

### N77(25M)\_DFT-s-OFDM\_PI\_2- BPSK\_Outer\_Full\_Mid\_CH

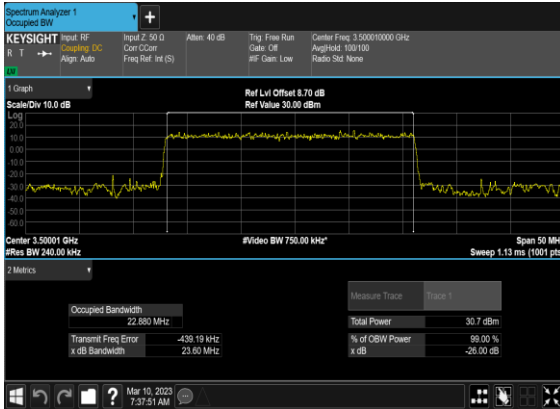

### N77(25M)\_DFT-s- OFDM\_QPSK\_Outer\_Full\_Mid\_CH

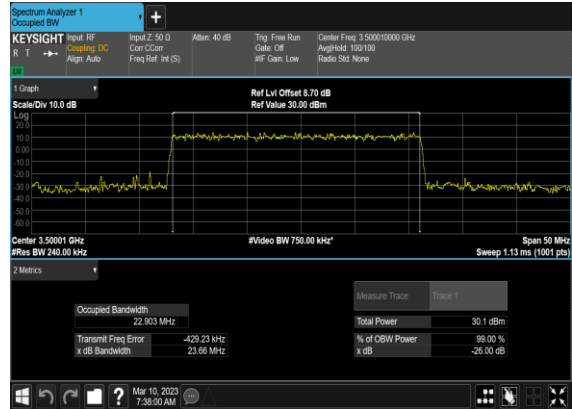

### N77(25M)\_CP- OFDM\_QPSK\_Outer\_Full\_Mid\_CH



### N77(25M)\_CP-OFDM\_16 QAM\_Outer\_Full\_Mid\_CH



### N77(25M)\_CP-OFDM\_64 QAM\_Outer\_Full\_Mid\_CH

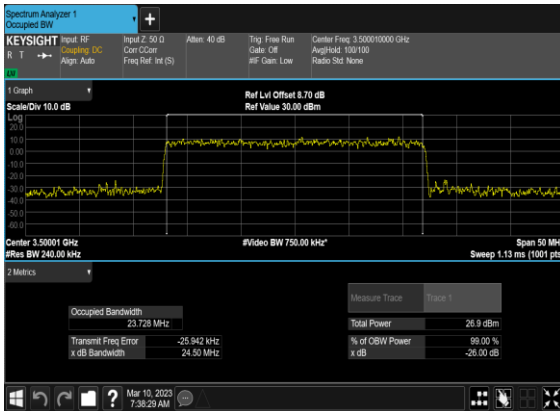

### N77(25M)\_CP-OFDM\_256 QAM\_Outer\_Full\_Mid\_CH

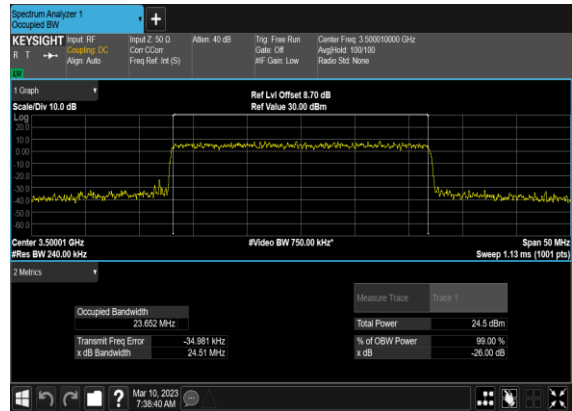

### N77(30M)\_DFT-s-OFDM\_PI\_2-BPSK\_Outer\_Full\_Mid\_CH

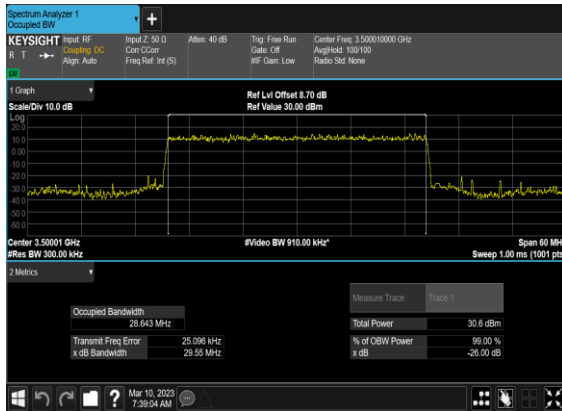

### N77(30M)\_DFT-s-OFDM\_QPSK\_Outer\_Full\_Mid\_CH

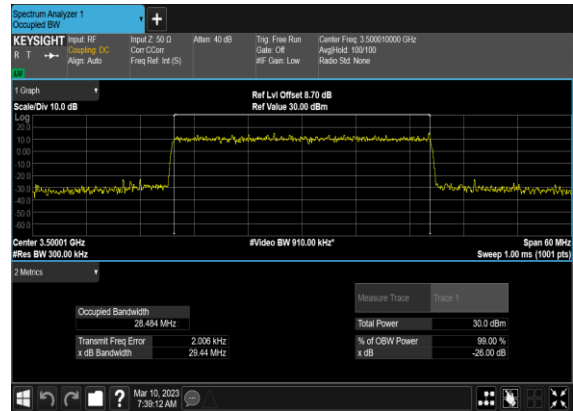

### N77(30M)\_CP-OFDM\_QPSK\_Outer\_Full\_Mid\_CH

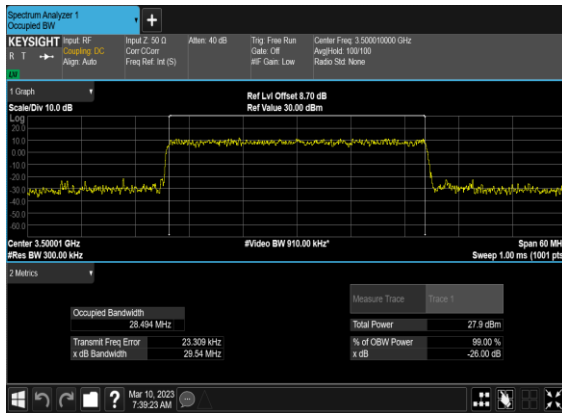

### N77(30M)\_CP-OFDM\_16QAM\_Outer\_Full\_Mid\_CH

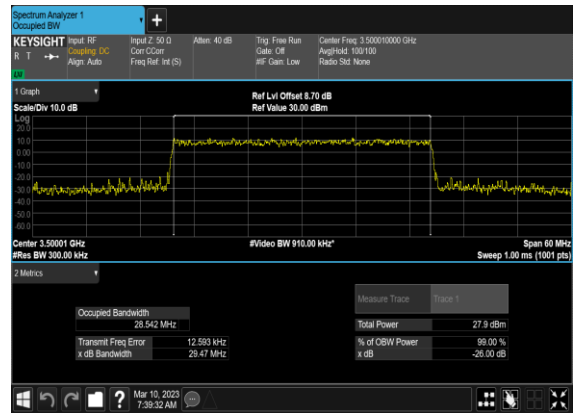

### N77(30M)\_CP-OFDM\_64QAM\_Outer\_Full\_Mid\_CH

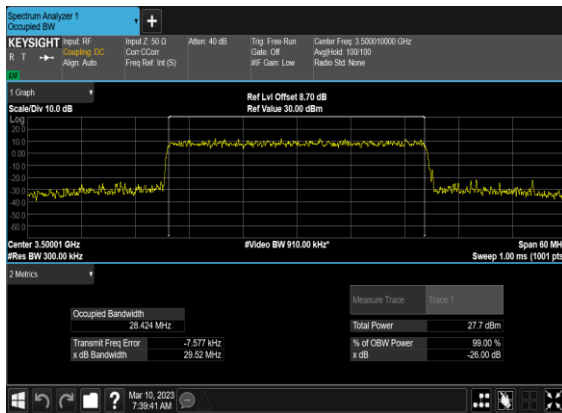

### N77(30M)\_CP-OFDM\_256QAM\_Outer\_Full\_Mid\_CH

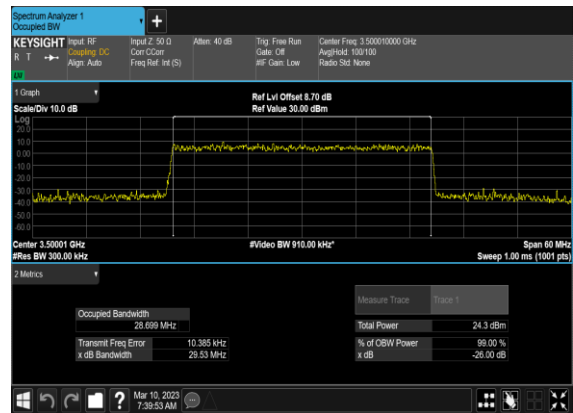

### N77(40M)\_DFT-s-OFDM\_PI\_2-BPSK\_Outer\_Full\_Mid\_CH

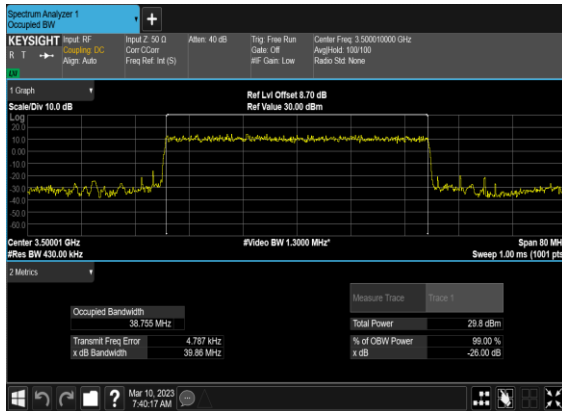

### N77(40M)\_DFT-s-OFDM\_QPSK\_Outer\_Full\_Mid\_CH

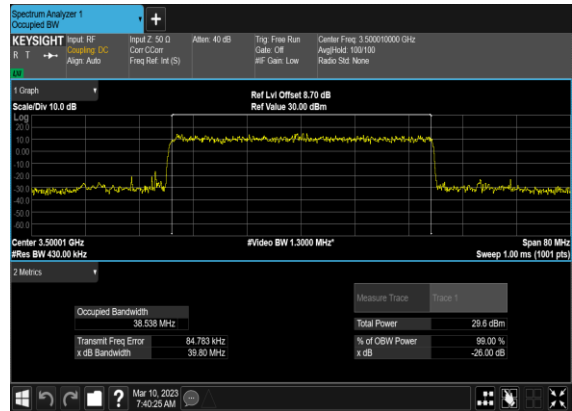

### N77(40M)\_CP-OFDM\_QPSK\_Outer\_Full\_Mid\_CH

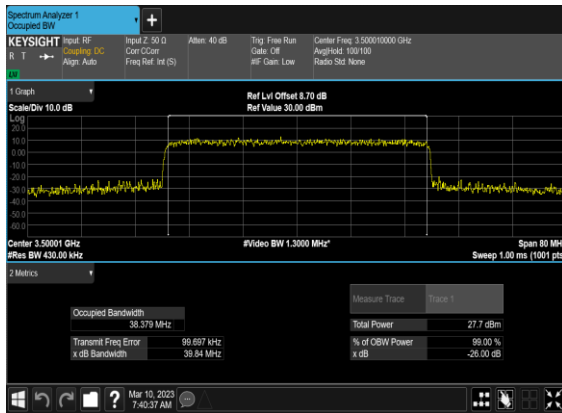

### N77(40M)\_CP-OFDM\_16QAM\_Outer\_Full\_Mid\_CH

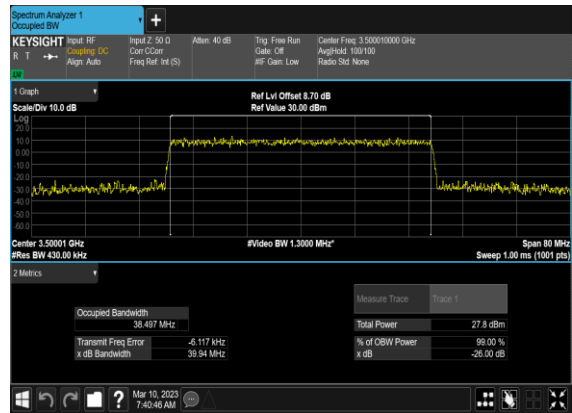

### N77(40M)\_CP-OFDM\_64QAM\_Outer\_Full\_Mid\_CH

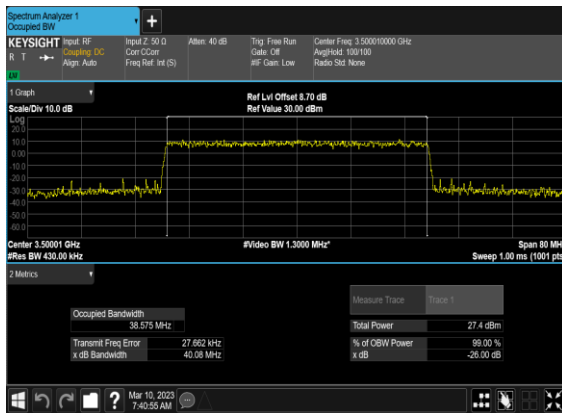

### N77(40M)\_CP-OFDM\_256QAM\_Outer\_Full\_Mid\_CH

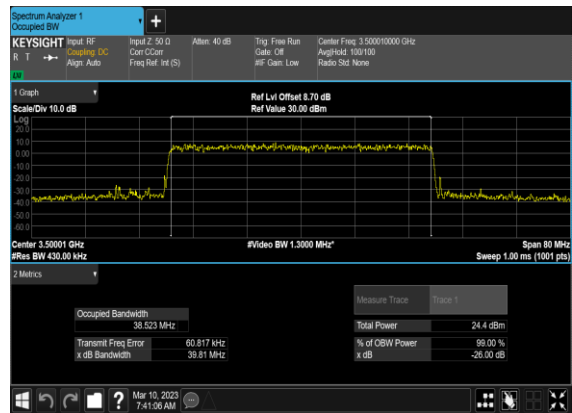

### N77(50M)\_DFT-s-OFDM\_PI\_2-BPSK\_Outer\_Full\_Mid\_CH

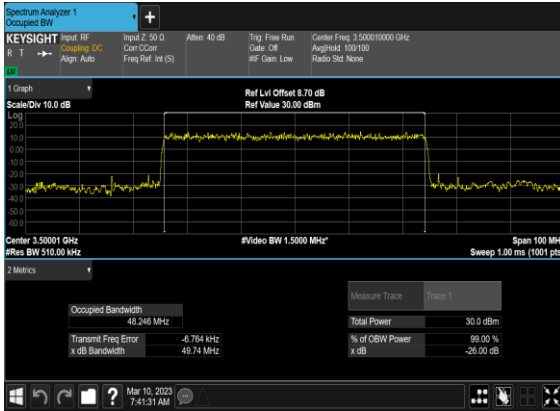

### N77(50M)\_DFT-s-OFDM\_QPSK\_Outer\_Full\_Mid\_CH

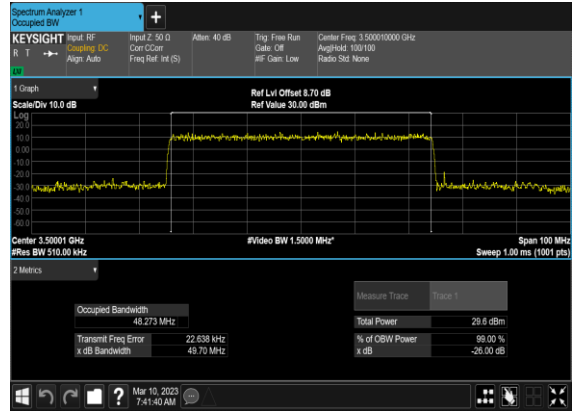

### N77(50M)\_CP-OFDM\_QPSK\_Outer\_Full\_Mid\_CH



### N77(50M)\_CP-OFDM\_16QAM\_Outer\_Full\_Mid\_CH

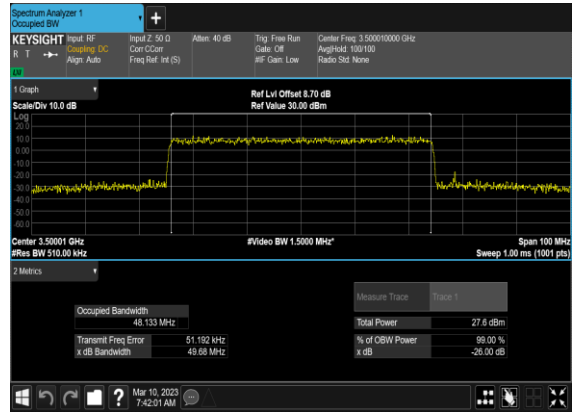

### N77(50M)\_CP-OFDM\_64QAM\_Outer\_Full\_Mid\_CH

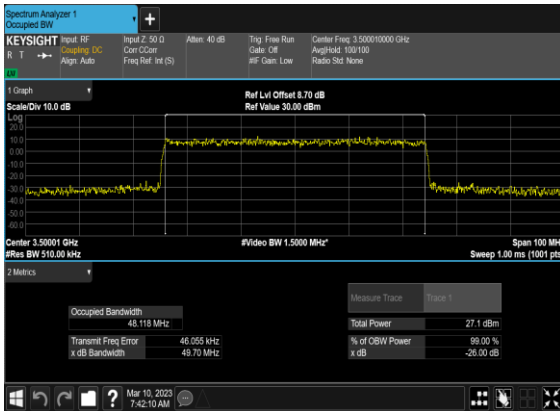

### N77(50M)\_CP-OFDM\_256QAM\_Outer\_Full\_Mid\_CH

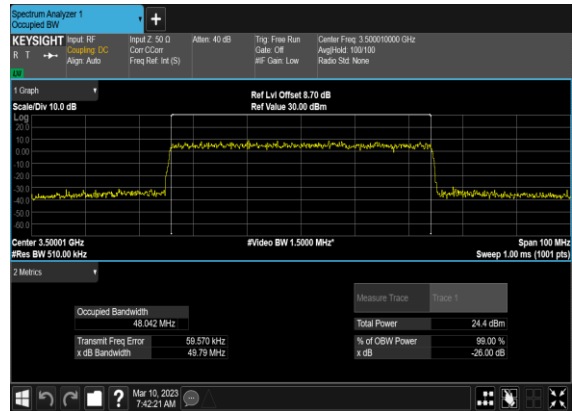

## Conducted Spurious Emissions

NR Band	SCS (kHz)	Bandwidth (MHz)	Arfcn	Freq (MHz)	Modulation	RB	Result	Verdict
77	15	10	630334	3455.01	DFT-s-OFDM BPSK	1@0	see graph	---
77	15	10	630334	3455.01	DFT-s-OFDM BPSK	1@0	see graph	PASS
77	15	10	630334	3455.01	DFT-s-OFDM BPSK	1@0	see graph	PASS
77	15	10	630334	3455.01	DFT-s-OFDM QPSK	1@0	see graph	---
77	15	10	630334	3455.01	DFT-s-OFDM QPSK	1@0	see graph	PASS
77	15	10	630334	3455.01	DFT-s-OFDM QPSK	1@0	see graph	PASS
77	15	10	633334	3500.01	DFT-s-OFDM BPSK	1@0	see graph	---
77	15	10	633334	3500.01	DFT-s-OFDM BPSK	1@0	see graph	PASS
77	15	10	633334	3500.01	DFT-s-OFDM BPSK	1@0	see graph	PASS
77	15	10	633334	3500.01	DFT-s-OFDM QPSK	1@0	see graph	---
77	15	10	633334	3500.01	DFT-s-OFDM QPSK	1@0	see graph	PASS
77	15	10	633334	3500.01	DFT-s-OFDM QPSK	1@0	see graph	PASS
77	15	10	636333	3544.995	DFT-s-OFDM BPSK	1@0	see graph	---
77	15	10	636333	3544.995	DFT-s-OFDM BPSK	1@0	see graph	PASS
77	15	10	636333	3544.995	DFT-s-OFDM BPSK	1@0	see graph	PASS
77	15	10	636333	3544.995	DFT-s-OFDM QPSK	1@0	see graph	---
77	15	10	636333	3544.995	DFT-s-OFDM QPSK	1@0	see graph	PASS
77	15	10	636333	3544.995	DFT-s-OFDM QPSK	1@0	see graph	PASS
77	15	25	630834	3462.51	DFT-s-OFDM BPSK	1@0	see graph	---
77	15	25	630834	3462.51	DFT-s-OFDM BPSK	1@0	see graph	PASS
77	15	25	630834	3462.51	DFT-s-OFDM BPSK	1@0	see graph	PASS
77	15	25	630834	3462.51	DFT-s-OFDM QPSK	1@0	see graph	---

77	15	25	630834	3462.51	DFT-s-OFDM QPSK	1@0	see graph	PASS
77	15	25	630834	3462.51	DFT-s-OFDM QPSK	1@0	see graph	PASS
77	15	25	633334	3500.01	DFT-s-OFDM BPSK	1@0	see graph	---
77	15	25	633334	3500.01	DFT-s-OFDM BPSK	1@0	see graph	PASS
77	15	25	633334	3500.01	DFT-s-OFDM BPSK	1@0	see graph	PASS
77	15	25	633334	3500.01	DFT-s-OFDM QPSK	1@0	see graph	---
77	15	25	633334	3500.01	DFT-s-OFDM QPSK	1@0	see graph	PASS
77	15	25	633334	3500.01	DFT-s-OFDM QPSK	1@0	see graph	PASS
77	15	25	635833	3537.495	DFT-s-OFDM BPSK	1@0	see graph	---
77	15	25	635833	3537.495	DFT-s-OFDM BPSK	1@0	see graph	PASS
77	15	25	635833	3537.495	DFT-s-OFDM BPSK	1@0	see graph	PASS
77	15	25	635833	3537.495	DFT-s-OFDM QPSK	1@0	see graph	---
77	15	25	635833	3537.495	DFT-s-OFDM QPSK	1@0	see graph	PASS
77	15	25	635833	3537.495	DFT-s-OFDM QPSK	1@0	see graph	PASS
77	15	50	631667	3475.005	DFT-s-OFDM BPSK	1@0	see graph	---
77	15	50	631667	3475.005	DFT-s-OFDM BPSK	1@0	see graph	PASS
77	15	50	631667	3475.005	DFT-s-OFDM BPSK	1@0	see graph	PASS
77	15	50	631667	3475.005	DFT-s-OFDM QPSK	1@0	see graph	---
77	15	50	631667	3475.005	DFT-s-OFDM QPSK	1@0	see graph	PASS
77	15	50	631667	3475.005	DFT-s-OFDM QPSK	1@0	see graph	PASS
77	15	50	633334	3500.01	DFT-s-OFDM BPSK	1@0	see graph	---
77	15	50	633334	3500.01	DFT-s-OFDM BPSK	1@0	see graph	PASS
77	15	50	633334	3500.01	DFT-s-OFDM BPSK	1@0	see graph	PASS
77	15	50	633334	3500.01	DFT-s-OFDM QPSK	1@0	see graph	---

77	15	50	633334	3500.01	DFT-s-OFDM QPSK	1@0	see graph	PASS
77	15	50	633334	3500.01	DFT-s-OFDM QPSK	1@0	see graph	PASS
77	15	50	635000	3525.0	DFT-s-OFDM BPSK	1@0	see graph	---
77	15	50	635000	3525.0	DFT-s-OFDM BPSK	1@0	see graph	PASS
77	15	50	635000	3525.0	DFT-s-OFDM BPSK	1@0	see graph	PASS
77	15	50	635000	3525.0	DFT-s-OFDM QPSK	1@0	see graph	---
77	15	50	635000	3525.0	DFT-s-OFDM QPSK	1@0	see graph	PASS
77	15	50	635000	3525.0	DFT-s-OFDM QPSK	1@0	see graph	PASS

### N77(10M)\_DFT-s-OFDM\_BPSK\_Edge\_1RB\_Left\_Low\_CH

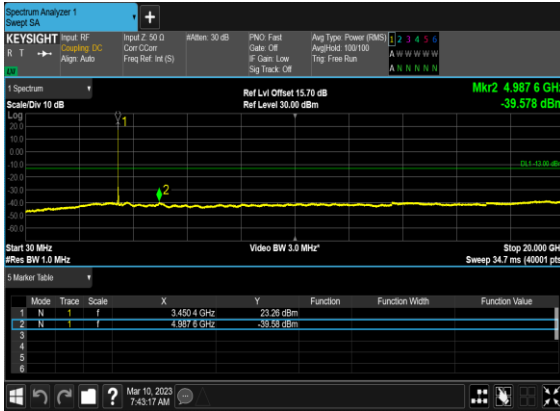

### N77(10M)\_DFT-s-OFDM\_BPSK\_Edge\_1RB\_Left\_Low\_CH

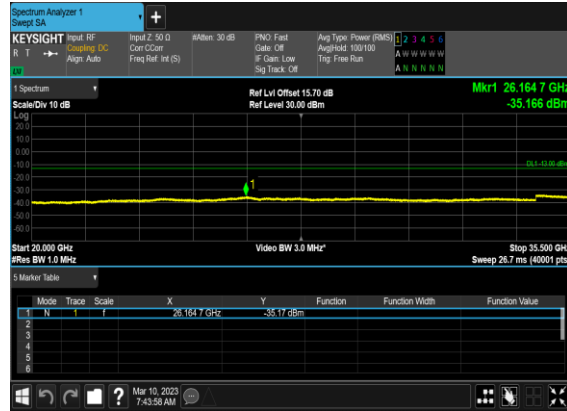

### N77(10M)\_DFT-s-OFDM\_QPSK\_Edge\_1RB\_Left\_Low\_CH



### N77(10M)\_DFT-s-OFDM\_QPSK\_Edge\_1RB\_Left\_Low\_CH

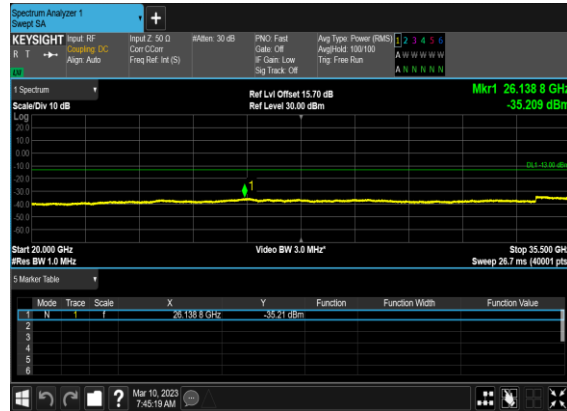

### N77(10M)\_DFT-s-OFDM\_BPSK\_Edge\_1RB\_Left\_Mid\_CH

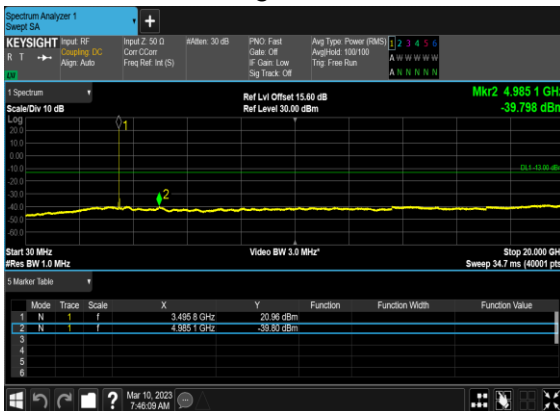

### N77(10M)\_DFT-s-OFDM\_BPSK\_Edge\_1RB\_Left\_Mid\_CH

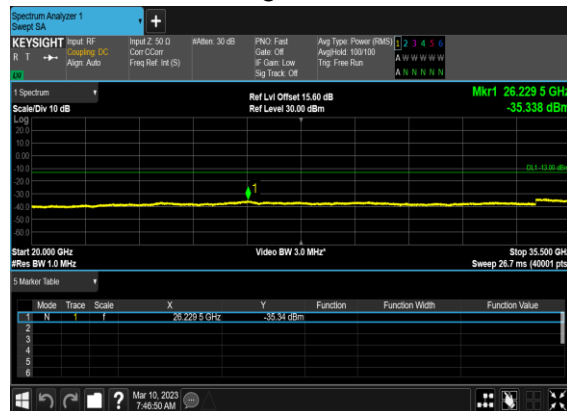

### N77(10M)\_DFT-s-OFDM\_QPSK\_Edge\_1RB\_Left\_Mid\_CH

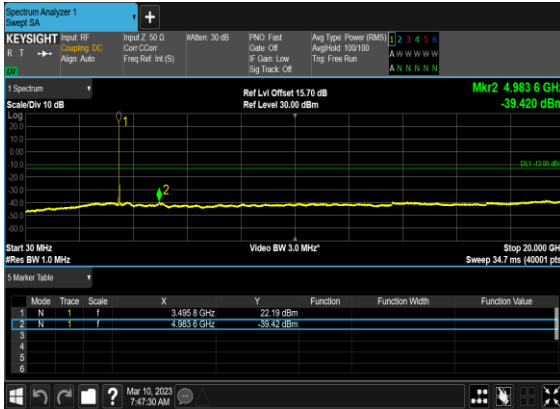

### N77(10M)\_DFT-s-OFDM\_QPSK\_Edge\_1RB\_Left\_Mid\_CH

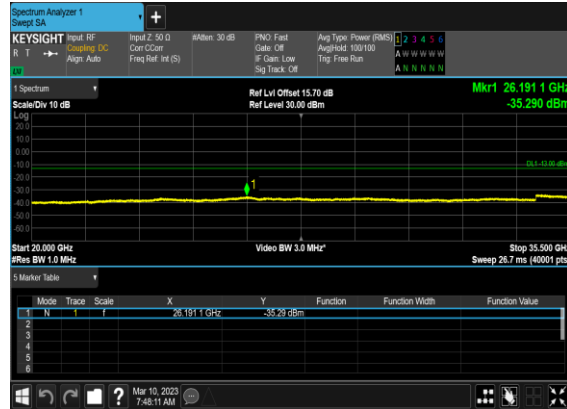

### N77(10M)\_DFT-s-OFDM\_BPSK\_Edge\_1RB\_Left\_High\_CH

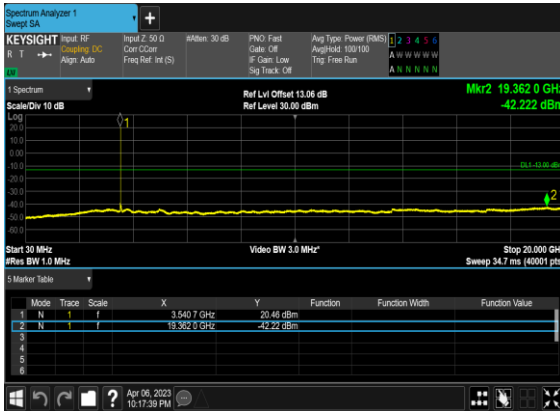

### N77(10M)\_DFT-s-OFDM\_BPSK\_Edge\_1RB\_Left\_High\_CH



### N77(10M)\_DFT-s-OFDM\_QPSK\_Edge\_1RB\_Left\_High\_CH

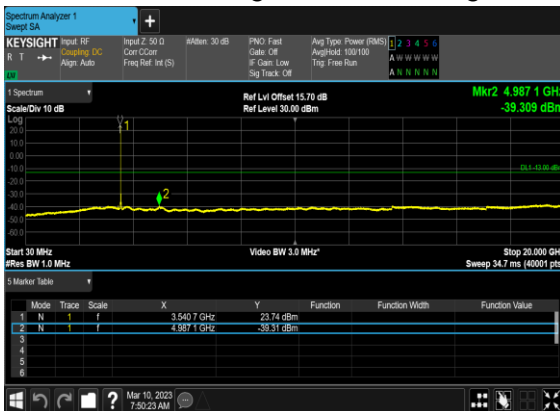

### N77(10M)\_DFT-s-OFDM\_QPSK\_Edge\_1RB\_Left\_High\_CH

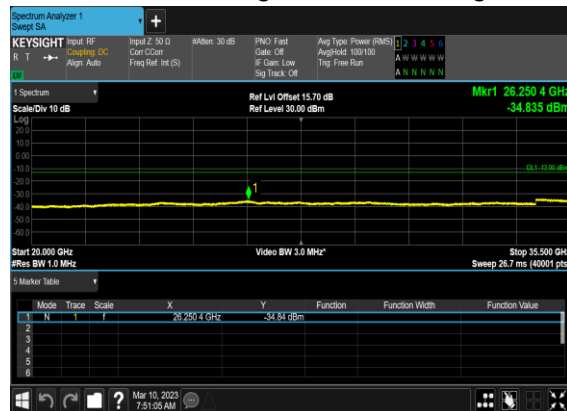

N77(25M)\_DFT-s-OFDM\_BPSK\_Edge\_1RB\_Left\_Low\_CH

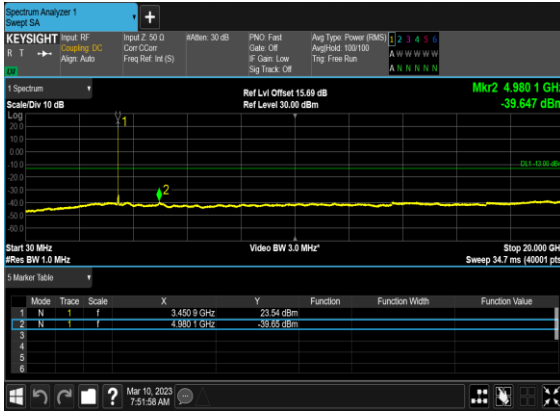

N77(25M)\_DFT-s-OFDM\_BPSK\_Edge\_1RB\_Left\_Low\_CH

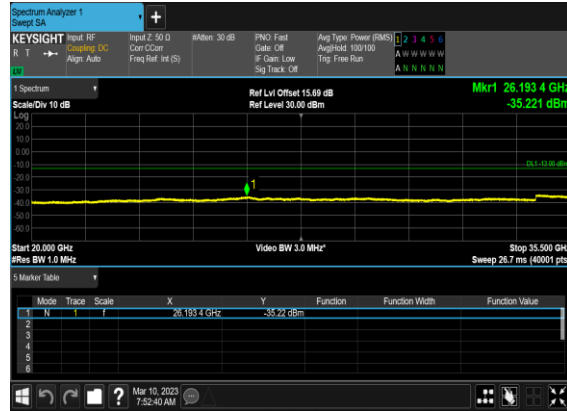

N77(25M)\_DFT-s-OFDM\_QPSK\_Edge\_1RB\_Left\_Low\_CH

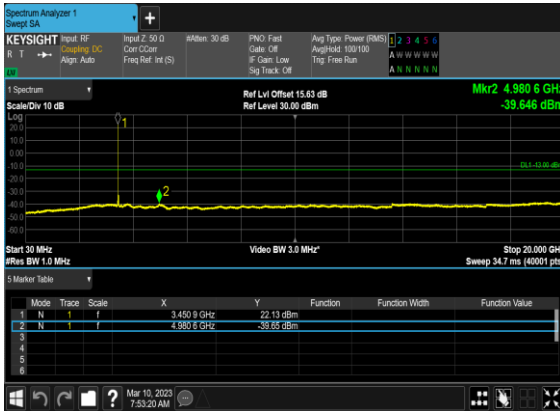

N77(25M)\_DFT-s-OFDM\_QPSK\_Edge\_1RB\_Left\_Low\_CH

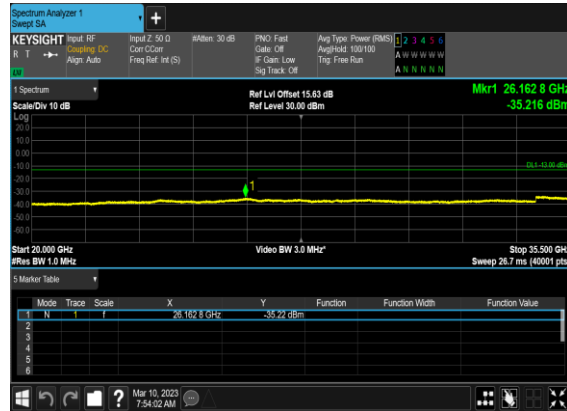

N77(25M)\_DFT-s-OFDM\_BPSK\_Edge\_1RB\_Left\_Mid\_CH

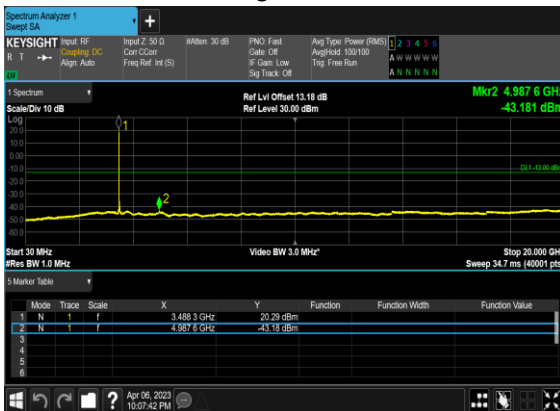

N77(25M)\_DFT-s-OFDM\_BPSK\_Edge\_1RB\_Left\_Mid\_CH

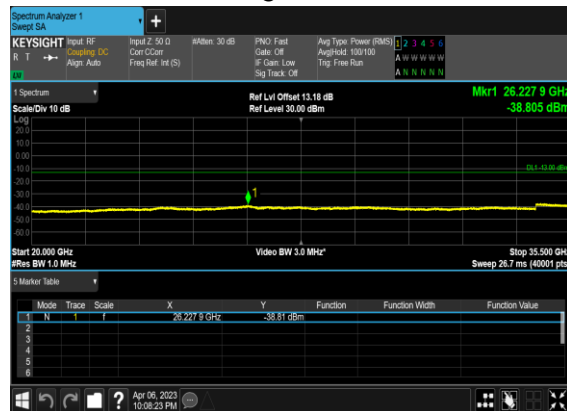

### N77(25M)\_DFT-s-OFDM\_QPSK\_Edge\_1RB\_Left\_Mid\_CH



### N77(25M)\_DFT-s-OFDM\_QPSK\_Edge\_1RB\_Left\_Mid\_CH

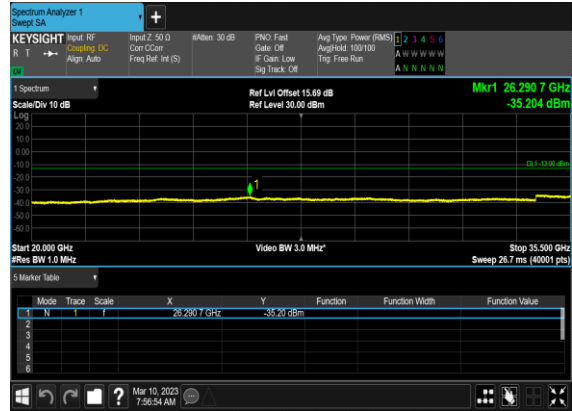

### N77(25M)\_DFT-s-OFDM\_BPSK\_Edge\_1RB\_Left\_High\_CH



### N77(25M)\_DFT-s-OFDM\_BPSK\_Edge\_1RB\_Left\_High\_CH

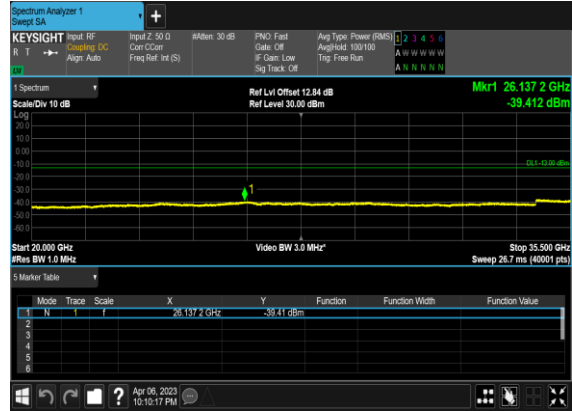

### N77(25M)\_DFT-s-OFDM\_QPSK\_Edge\_1RB\_Left\_High\_CH



### N77(25M)\_DFT-s-OFDM\_QPSK\_Edge\_1RB\_Left\_High\_CH

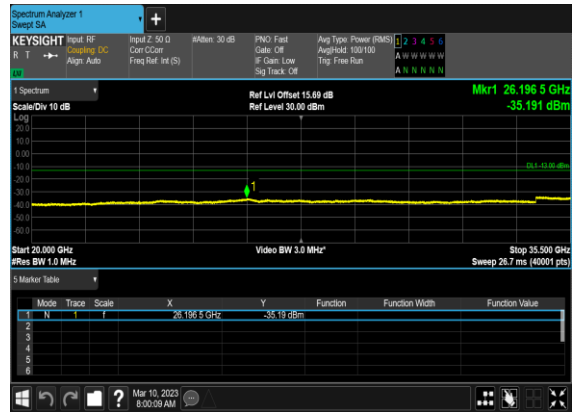

N77(50M)\_DFT-s-OFDM\_BPSK\_Edge\_1RB\_Left\_Low\_CH

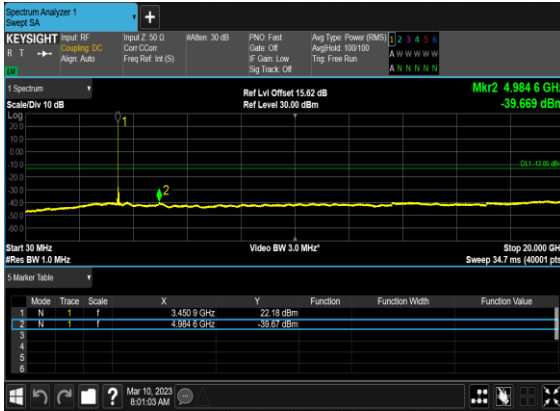

N77(50M)\_DFT-s-OFDM\_BPSK\_Edge\_1RB\_Left\_Low\_CH

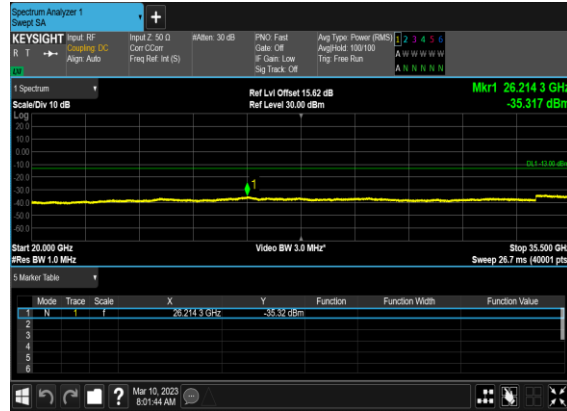

N77(50M)\_DFT-s-OFDM\_QPSK\_Edge\_1RB\_Left\_Low\_CH

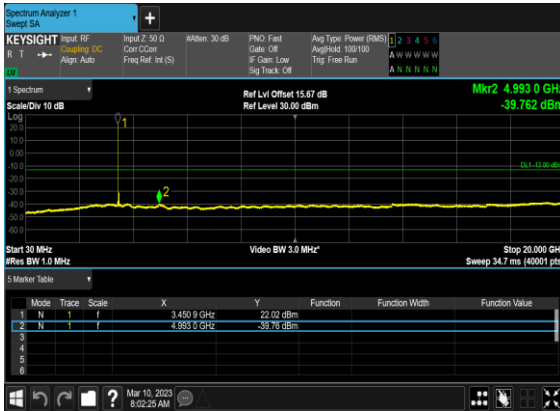

N77(50M)\_DFT-s-OFDM\_QPSK\_Edge\_1RB\_Left\_Low\_CH

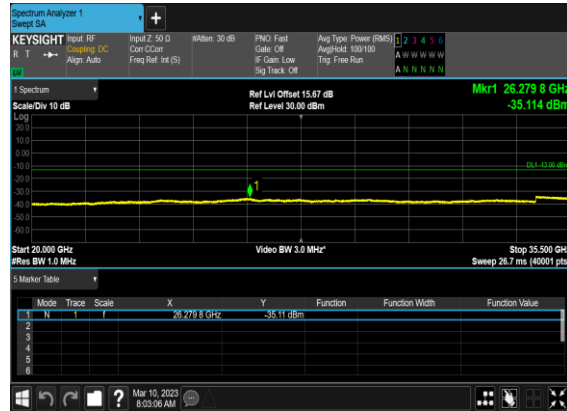

N77(50M)\_DFT-s-OFDM\_BPSK\_Edge\_1RB\_Left\_Mid\_CH

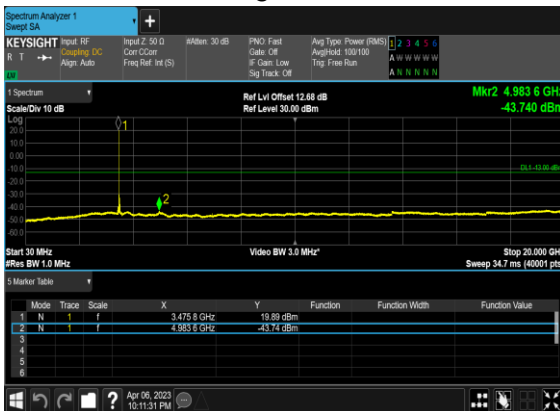

N77(50M)\_DFT-s-OFDM\_BPSK\_Edge\_1RB\_Left\_Mid\_CH

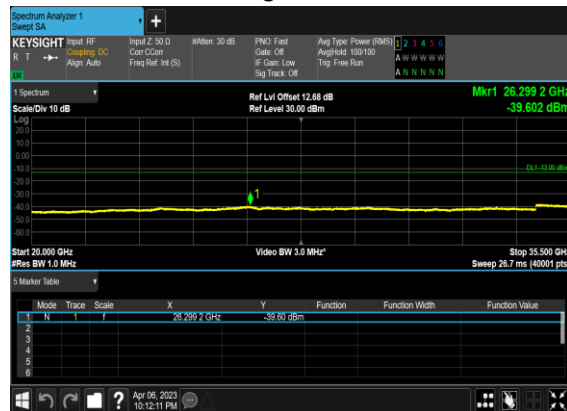

### N77(50M)\_DFT-s-OFDM\_QPSK\_Edge\_1RB\_Left\_Mid\_CH

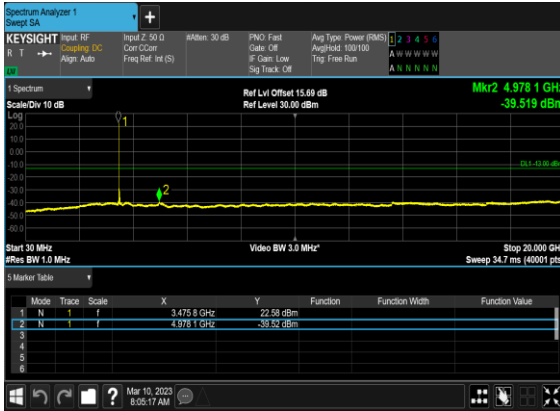

### N77(50M)\_DFT-s-OFDM\_QPSK\_Edge\_1RB\_Left\_Mid\_CH

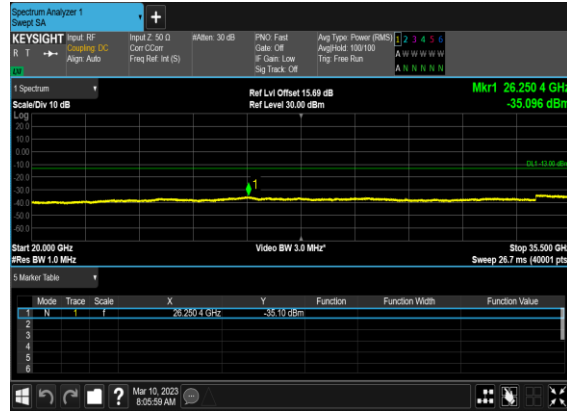

### N77(50M)\_DFT-s-OFDM\_BPSK\_Edge\_1RB\_Left\_High\_CH



### N77(50M)\_DFT-s-OFDM\_BPSK\_Edge\_1RB\_Left\_High\_CH

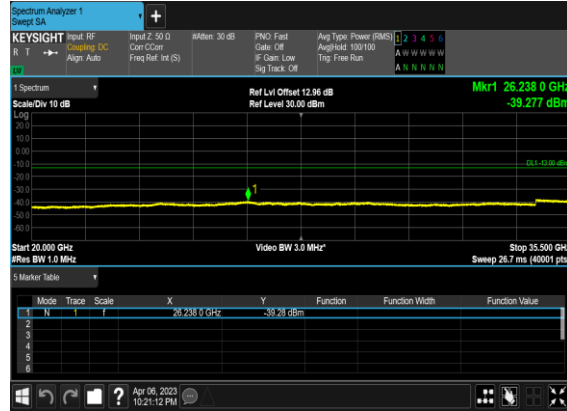

### N77(50M)\_DFT-s-OFDM\_QPSK\_Edge\_1RB\_Left\_High\_CH

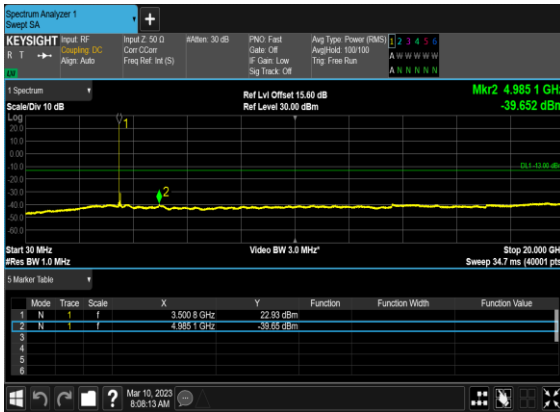

### N77(50M)\_DFT-s-OFDM\_QPSK\_Edge\_1RB\_Left\_High\_CH

