



FCC RF Test Report

APPLICANT : Motorola Mobility LLC
EQUIPMENT : Mobile Cellular Phone
BRAND NAME : Motorola
MODEL NAME : XT2305-1
FCC ID : IHDT56AL5
STANDARD : 47 CFR Part 2, 27 Subpart O (3700-3980MHz)
CLASSIFICATION : PCS Licensed Transmitter Held to Ear (PCE)
TEST DATE(S) : Mar. 29, 2023 ~ Apr. 10, 2023

We, Sporton International Inc. (KunShan), would like to declare that the tested sample has been evaluated in accordance with the procedures given in ANSI C63.26-2015 and shown compliance with the applicable technical standards.

This report contains data that were produced under subcontract by Sporton International Inc. (ShenZhen).

The test results in this report apply exclusively to the tested model / sample. Without written approval of Sporton International Inc. (KunShan), the test report shall not be reproduced except in full.

Jason Jia

Approved by: Jason Jia



Sporton International Inc. (Kunshan)

**No. 1098, Pengxi North Road, Kunshan Economic Development Zone Jiangsu Province 215300
People's Republic of China**



TABLE OF CONTENTS

REVISION HISTORY...3
SUMMARY OF TEST RESULT...4
1 GENERAL DESCRIPTION...5
1.1 Applicant...5
1.2 Manufacturer...5
1.3 Product Feature of Equipment Under Test...5
1.4 Product Specification of Equipment Under Test...5
1.5 Modification of EUT...6
1.6 Specification of Accessory...6
1.7 Maximum EIRP and Emission Designator...7
1.8 Testing Location...9
1.9 Test Software...9
1.10 Applicable Standards...9
2 TEST CONFIGURATION OF EQUIPMENT UNDER TEST...10
2.1 Test Mode...10
2.2 Connection Diagram of Test System...11
2.3 Support Unit used in test configuration and system...11
2.4 Measurement Results Explanation Example...11
2.5 Frequency List of Low/Middle/High Channels...12
3 CONDUCTED TEST ITEMS...15
3.1 Measuring Instruments...15
3.2 Test Setup...15
3.3 Test Result of Conducted Test...15
3.4 Conducted Output Power and EIRP...16
3.5 Peak-to-Average Ratio...17
3.6 Occupied Bandwidth...18
3.7 Conducted Band Edge...19
3.8 Conducted Spurious Emission...20
3.9 Frequency Stability...21
4 RADIATED TEST ITEMS...22
4.1 Measuring Instruments...22
4.2 Test Setup...22
4.3 Test Result of Radiated Test...23
4.4 Radiated Spurious Emission...24
5 LIST OF MEASURING EQUIPMENT...25
6 UNCERTAINTY OF EVALUATION...26
APPENDIX A. TEST RESULTS OF CONDUCTED TEST
APPENDIX B. TEST RESULTS OF RADIATED TEST
APPENDIX C. TEST SETUP PHOTOGRAPHS



SUMMARY OF TEST RESULT

Report Section	FCC Rule	Description	Limit	Result	Remark
3.4	§2.1046	Conducted Output Power	Reporting Only	PASS	-
	§27.50(j)(3)	Equivalent Isotropic Radiated Power (5G NR n77, n78)	EIRP < 1Watt		
3.5	§27.50(j)(4)	Peak-to-Average Ratio	<13 dB	PASS	-
3.6	§2.1049	Occupied Bandwidth	Reporting Only	PASS	-
3.7	§2.1051 §27.53(l)(2)	Conducted Band Edge Measurement (5G NR n77, n78)	< 43+10log ₁₀ (P[Watts])	PASS	-
3.8	§2.1051 §27.53(l)(2)	Conducted Spurious Emission (5G NR n77, n78)	< 43+10log ₁₀ (P[Watts])	PASS	-
3.9	§27.54	Frequency Stability Temperature & Voltage	Within Authorized Band	PASS	-
4.4	§2.1053 §27.53(l)(2)	Radiated Spurious Emission (5G NR n77, n78)	< 43+10log ₁₀ (P[Watts])	PASS	Under limit 41.28 dB at 11640.00 MHz

Declaration of Conformity:
The test results with all measurement uncertainty excluded are presented in accordance with the regulation limits or requirements declared by manufacturers.
Comments and Explanations:
The declared of product specification for EUT presented in the report are provided by the manufacturer, and the manufacturer takes all the responsibilities for the accuracy of product specification.



1 General Description

1.1 Applicant

Motorola Mobility LLC
222 W,Merchandise Mart Plaza, Chicago IL 60654 USA

1.2 Manufacturer

Motorola Mobility LLC
222 W,Merchandise Mart Plaza, Chicago IL 60654 USA

1.3 Product Feature of Equipment Under Test

Product Feature	
Equipment	Mobile Cellular Phone
Brand Name	Motorola
Model Name	XT2305-1
FCC ID	IHDT56AL5
IMEI Code	Conducted : 351048560017430/351072410011450 Radiation : 351048560020038/351048560020046
HW Version	DVT2
SW Version	TTT33.46
EUT Stage	Identical Prototype

1.4 Product Specification of Equipment Under Test

Standards-related Product Specification	
Tx/Rx Frequency	5G NR n77: 3700 MHz ~ 3980 MHz 5G NR n78: 3700 MHz ~ 3800 MHz
SCS	15kHz, 30kHz
Bandwidth	n77/n78(15kHz): 10 / 15 / 20 / 25 / 30 / 40 / 50MHz n77/n78(30kHz): 10 / 15 / 20 / 25 / 30 / 40 / 50 / 60 / 70 / 80 / 90 / 100MHz
Antenna Gain	<Ant. 2> 5G NR n77: -9.2 dBi 5G NR n78: -9.2 dBi <Ant. 4> 5G NR n77: -8.8 dBi 5G NR n78: -8.8 dBi <Ant. 5> 5G NR n77: -11.5 dBi 5G NR n78: -11.5 dBi <Ant. 7> 5G NR n77: -10.3 dBi 5G NR n78: -10.3 dBi
Type of Modulation	CP-OFDM: QPSK / 16QAM / 64QAM / 256QAM DFT-s-OFDM: PI/2 BPSK / QPSK / 16QAM / 64QAM / 256QAM



Remark:

1. The maximum EIRP is calculated from max output power and max antenna gain, only the maximum EIRP of Ant.4 for n77/n78 SISO, and Ant.(4+2) for n77/n78 MIMO are shown in the report.
2. The device supports n77/n78(1T4R) SRS resources on Antenna 2/4/5/7, only the test data of worst Ant.4 is showed in the report according to the maximum power.
3. The device supports HPUE(PC2) mode for 5G NR n77, and HPUE(PC1.5) mode for n77 MIMO.
4. 5G NR n77/n78 support UL MIMO mode for Ant(4+2)/ Ant(4+5) / Ant(7+2) / Ant(7+5), only the worst test data of Ant.(4+2) is shown in the report.
5. For n77/n78 MIMO mode, the Ant (4+2) MIMO Gain = $10 \log[(10^{Ant.4/20} + 10^{Ant.2/20})^2 / 2] = -5.99\text{dBi}$.
6. For n77/n78 MIMO mode, the conducted BE/Spurious are tested at single antenna port and add $10 \cdot \log(N_{ANT})$ according to KDB 662911 D01.
7. 5G NR n77/n78 support SA and NSA mode. The whole testing has assessed SA mode by referring to the higher conducted power for conducted test items.
8. All the supported EN-DC combinations are verified conducted power, only the EN-DC combination with highest power are shown in the report.
9. The EN-DC mode combination could be referred to the product spec.

1.5 Modification of EUT

No modifications are made to the EUT during all test items.

1.6 Specification of Accessory

Specification of Accessory				
AC Adapter 1	Brand Name	Motorola(Chenyang)	Model Name	MC-681N
AC Adapter 2	Brand Name	Motorola(Acbel)	Model Name	MC-681N
Battery	Brand Name	Motorola(AmpereX)	Model Name	PG44
USB Cable 1	Brand Name	Motorola (Saibao)	Model Name	SC18D86731
USB Cable 2	Brand Name	Motorola (Saibao)	Model Name	SC18D71644



1.7 Maximum EIRP and Emission Designator

5G NR n77 UL MIMO for SCS 15kHz		PI/2 BPSK / QPSK		16QAM / 64QAM / 256QAM	
BW (MHz)	Frequency Range (MHz)	Maximum EIRP(W)	Emission Designator (99%OBW)	Maximum EIRP(W)	Emission Designator (99%OBW)
10	3705.000 ~ 3975.000	0.1754	9M26G7D	0.1400	9M30W7D
15	3705.505 ~ 3972.495	0.1746	14M1G7D	0.1387	14M1W7D
20	3710.010 ~ 3969.990	0.1816	18M9G7D	0.1422	19M0W7D
25	3712.500 ~ 3967.500	0.1742	23M7G7D	0.1432	23M8W7D
30	3715.005 ~ 3964.980	0.1803	28M6G7D	0.1409	28M6W7D
40	3720.000 ~ 3960.000	0.1754	38M6G7D	0.1403	38M6W7D
50	3725.010 ~ 3954.990	0.1824	48M3G7D	0.1432	48M3W7D
5G NR n77 UL MIMO for SCS 30kHz		PI/2 BPSK / QPSK		16QAM / 64QAM / 256QAM	
BW (MHz)	Frequency Range (MHz)	Maximum EIRP(W)	Emission Designator (99%OBW)	Maximum EIRP(W)	Emission Designator (99%OBW)
10	3705.00 ~ 3975.00	0.1726	8M61G7D	0.1355	8M60W7D
15	3707.52 ~ 3972.48	0.1786	13M6G7D	0.1294	13M6W7D
20	3710.01 ~ 3969.99	0.1774	18M2G7D	0.1346	18M2W7D
25	3712.50 ~ 3967.50	0.1746	23M1G7D	0.1409	23M2W7D
30	3715.02 ~ 3964.98	0.1786	27M8G7D	0.1374	27M9W7D
40	3720.00 ~ 3960.00	0.1754	38M0G7D	0.1294	37M9W7D
50	3725.01 ~ 3954.99	0.1786	47M5G7D	0.1300	47M6W7D
60	3730.02 ~ 3949.98	0.1762	58M0G7D	0.1312	57M9W7D
70	3735.00 ~ 3945.00	0.1766	67M6G7D	0.1306	67M6W7D
80	3740.01 ~ 3939.99	0.1754	77M5G7D	0.1282	77M6W7D
90	3745.02 ~ 3934.98	0.1758	87M4G7D	0.1288	87M5W7D
100	3750.00 ~ 3930.00	0.1791	97M6G7D	0.1387	97M6W7D



5G NR n78 MIMO for SCS 15kHz		PI/2 BPSK / QPSK		16QAM / 64QAM / 256QAM	
BW (MHz)	Frequency Range (MHz)	Maximum EIRP(W)	Emission Designator (99%OBW)	Maximum EIRP(W)	Emission Designator (99%OBW)
10	3705.000 ~ 3795.000	0.0463	9M26G7D	0.0384	9M30W7D
15	3705.505 ~ 3792.495	0.0471	14M1G7D	0.0364	14M1W7D
20	3710.010 ~ 3789.990	0.0470	18M9G7D	0.0366	19M0W7D
25	3712.500 ~ 3787.500	0.0467	23M7G7D	0.0392	23M8W7D
30	3715.005 ~ 3784.995	0.0467	28M6G7D	0.0378	28M6W7D
40	3720.000 ~ 3780.000	0.0459	38M6G7D	0.0387	38M6W7D
50	3725.010 ~ 3774.990	0.0497	48M3G7D	0.0371	48M3W7D
5G NR n78 MIMO for SCS 30kHz		PI/2 BPSK / QPSK		16QAM / 64QAM / 256QAM	
BW (MHz)	Frequency Range (MHz)	Maximum EIRP(W)	Emission Designator (99%OBW)	Maximum EIRP(W)	Emission Designator (99%OBW)
10	3705.00 ~ 3795.00	0.0488	8M61G7D	0.0394	8M60W7D
15	3707.52 ~ 3792.48	0.0486	13M6G7D	0.0387	13M6W7D
20	3710.01 ~ 3789.99	0.0473	18M2G7D	0.0398	18M2W7D
25	3712.50 ~ 3787.50	0.0470	23M1G7D	0.0399	23M2W7D
30	3715.02 ~ 3784.98	0.0485	27M8G7D	0.0386	27M9W7D
40	3720.00 ~ 3780.00	0.0480	38M0G7D	0.0401	37M9W7D
50	3725.01 ~ 3774.99	0.0491	47M5G7D	0.0383	47M6W7D
60	3730.02 ~ 3769.98	0.0481	58M0G7D	0.0386	57M9W7D
70	3735.00 ~ 3765.00	0.0489	67M6G7D	0.0385	67M6W7D
80	3740.01 ~ 3759.99	0.0488	77M5G7D	0.0378	77M6W7D
90	3745.02 ~ 3754.98	0.0485	87M4G7D	0.0386	87M5W7D
100	3750.00	0.0490	97M6G7D	0.0375	97M6W7D

Note:

- 5G NR Band n77 overlaps the entire frequency range of Band n78, and n77 power > n78 power, therefore the conducted test results of n77 provided in this report cover n78.
- All modulations have been tested, and only the worst test results of PSK & QAM are shown in the report.

1.8 Testing Location

Sporton International Inc. (Kunshan) is accredited to ISO/IEC 17025:2017 by American Association for Laboratory Accreditation with Certificate Number 5145.02.

Test Firm	Sporton International Inc. (Kunshan)		
Test Site Location	No. 1098, Pengxi North Road, Kunshan Economic Development Zone Jiangsu Province 215300 People's Republic of China TEL : +86-512-57900158		
Test Site No.	Sporton Site No.	FCC Designation No.	FCC Test Firm Registration No.
	03CH04-KS	CN1257	314309

Sporton International Inc. (Shenzhen) is accredited to ISO/IEC 17025:2017 by American Association for Laboratory Accreditation with Certificate Number 5145.01.

Test Firm	Sporton International Inc. (Shenzhen)		
Test Site Location	1/F, 2/F, Bldg 5, Shiling Industrial Zone, Xinwei Village, Xili, Nanshan, Shenzhen, 518055 People's Republic of China TEL: +86-755-86379589 FAX: +86-755-86379595		
Test Site No.	Sporton Site No.	FCC Designation No.	FCC Test Firm Registration No.
	TH01-SZ	CN1256	421272

Note: Test data subcontracted: Test case of conducted in section 3 of this report

1.9 Test Software

Item	Site	Manufacturer	Name	Version
1.	03CH04-KS	AUDIX	E3	6.2009-8-24al

1.10 Applicable Standards

According to the specifications of the manufacturer, the EUT must comply with the requirements of the following standards:

- ♦ 47 CFR Part 2, 27
- ♦ ANSI C63.26-2015
- ♦ FCC KDB 971168 D01 Power Meas License Digital Systems v03r01
- ♦ FCC KDB 412172 D01 Determining ERP and EIRP v01r01

Remark:

All test items were verified and recorded according to the standards and without any deviation during the test.



2 Test Configuration of Equipment Under Test

2.1 Test Mode

Antenna port conducted and radiated test items are performed according to KDB 971168 D01 Power Meas License Digital Systems v03r01 with maximum output power.

For radiated measurement, pre-scanned in three orthogonal panels, X, Y, Z. The worst cases (X plane) were recorded in this report.

The device is investigated from 30MHz to 10 times of fundamental signal for radiated spurious emission test under different RB size/offset and modulations in exploratory test. Subsequently, only the worst case emissions are reported.

Orthogonal Planes of EUT	X Plane	Y Plane	Z Plane
			

Test Items	5G NR	Bandwidth (MHz)										Modulation					RB #		Test Channel		
		10	15	20	25	30	40	50	60	70~90	100	PI/2 BPSK	QPSK	16QAM	64QAM	256QAM	1	Full	L	M	H
Max. Output Power	n77	v	v	v	v	v	v	v	v	v	v	v	v	v	v	v	v	v	v	v	v
	n78	v	v	v	v	v	v	v	v	v	v	v	v	v	v	v	v	v	v	v	v
Peak-to-Average Ratio	n77			v								v	v				v	v	v	v	v
26dB and 99% Bandwidth	n77	v	v	v	v	v	v	v	v	v	v	v	v	v	v	v		v		v	
Conducted Band Edge	n77	v			v			v			v	v	v				v	v	v		v
Conducted Spurious Emission	n77	v			v			v			v	v	v				v		v	v	v
Frequency Stability	n77			v									v					v		v	
E.I.R.P	n77	v	v	v	v	v	v	v	v	v	v	v	v	v	v	v	v	v	v	v	v
	n78	v	v	v	v	v	v	v	v	v	v	v	v	v	v	v	v	v	v	v	v
Radiated Spurious Emission	n77	Worst Case																	v	v	v
Note	1. The mark "v" means that this configuration is chosen for testing 2. The mark "-" means that this bandwidth is not supported. 3. The device is investigated from 30MHz to 10 times of fundamental signal for radiated spurious emission test under different RB size/offset and modulations in exploratory test. Subsequently, only the worst case emissions are reported. 4. Frequency Stability : Normal Voltage = 3.91V; Low Voltage =3.40V; High Voltage =4.50V.																				

2.2 Connection Diagram of Test System

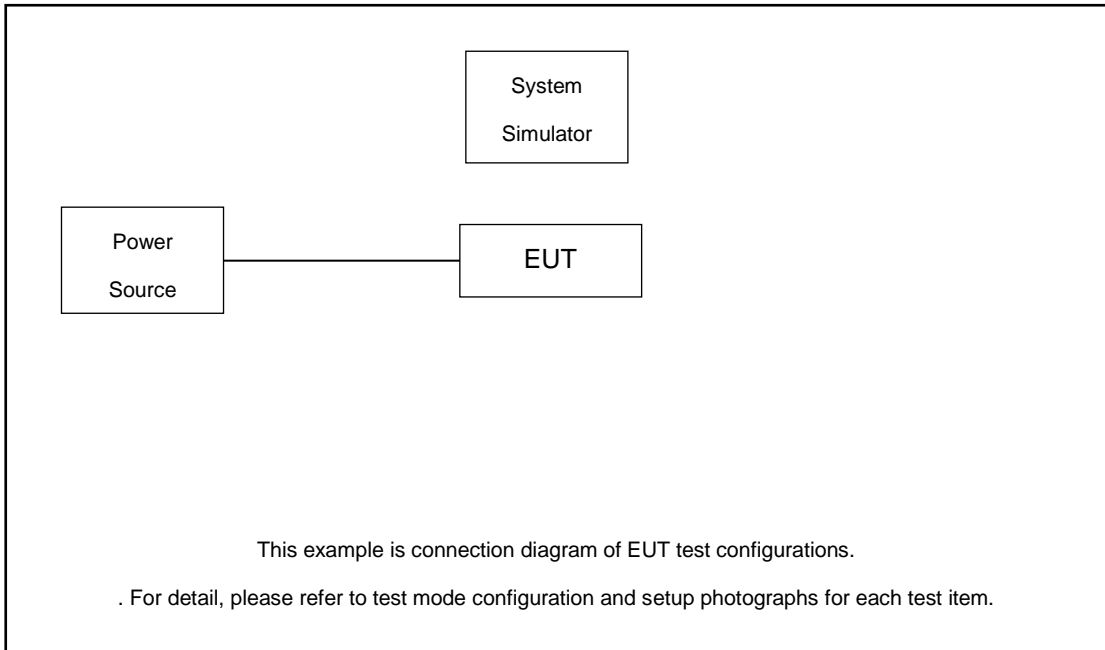

2.3 Support Unit used in test configuration and system

Item	Equipment	Trade Name	Model No.	FCC ID	Data Cable	Power Cord
1.	DC Power Supply	GW	GPS-3030D	N/A	N/A	Unshielded, 1.8 m
2.	LTE Base Station	Anritsu	MT8821C	N/A	N/A	Unshielded, 1.8 m
3.	NR Base Station	Anritsu	MT8000A	N/A	N/A	Unshielded, 1.8 m

2.4 Measurement Results Explanation Example

For all conducted test items:

The offset level is set in the spectrum analyzer to compensate the RF cable loss and attenuator factor between EUT conducted output port and spectrum analyzer. With the offset compensation, the spectrum analyzer reading level is exactly the EUT RF output level.

The spectrum analyzer offset is derived from RF cable loss and attenuator factor.

$$\text{Offset} = \text{RF cable loss} + \text{attenuator factor}.$$

Following shows an offset computation example with cable loss 5.69 dB and 10dB attenuator.

Example :

$$\begin{aligned} \text{Offset(dB)} &= \text{RF cable loss(dB)} + \text{attenuator factor(dB)}. \\ &= 5.69 + 10 = 15.69 \text{ (dB)} \end{aligned}$$



2.5 Frequency List of Low/Middle/High Channels

5G n77 (15kHz) Channel and Frequency List				
BW [MHz]	Channel/Frequency(MHz)	Lowest	Middle	Highest
50	Channel	648334	656000	663666
	Frequency	3725.01	3840	3954.99
40	Channel	648000	656000	664000
	Frequency	3720	3840	3960
30	Channel	647667	656000	664332
	Frequency	3715.005	3840	3964.98
25	Channel	647500	656000	664500
	Frequency	3712.5	3840	3967.5
20	Channel	647334	656000	664666
	Frequency	3710.01	3840	3969.99
15	Channel	647167	656000	664833
	Frequency	3707.505	3840	3972.495
10	Channel	647000	656000	665000
	Frequency	3705	3840	3975

5G n78(15kHz) Channel and Frequency List				
BW [MHz]	Channel/Frequency(MHz)	Lowest	Middle	Highest
50	Channel	648334	650000	651666
	Frequency	3725.01	3750	3774.99
40	Channel	648000	650000	652000
	Frequency	3720	3750	3780
30	Channel	647667	650000	652333
	Frequency	3715.005	3750	3784.995
25	Channel	647500	650000	652500
	Frequency	3712.5	3750	3787.5
20	Channel	647334	650000	652666
	Frequency	3710.01	3750	3789.99
15	Channel	647167	650000	652833
	Frequency	3707.505	3750	3792.495
10	Channel	647000	650000	653000
	Frequency	3705	3750	3795



5G n77 (30kHz) Channel and Frequency List				
BW [MHz]	Channel/Frequency(MHz)	Lowest	Middle	Highest
100	Channel	650000	656000	662000
	Frequency	3750	3840	3930
90	Channel	649668	656000	662332
	Frequency	3745.02	3840	3934.98
80	Channel	649334	656000	662666
	Frequency	3740.01	3840	3939.99
70	Channel	649000	656000	663000
	Frequency	3735	3840	3945
60	Channel	648668	656000	663332
	Frequency	3730.02	3840	3949.98
50	Channel	648334	656000	663666
	Frequency	3725.01	3840	3954.99
40	Channel	648000	656000	664000
	Frequency	3720	3840	3960
30	Channel	647668	656000	664332
	Frequency	3715.02	3840	3964.98
25	Channel	647500	656000	664500
	Frequency	3712.5	3840	3967.5
20	Channel	647334	656000	664666
	Frequency	3710.01	3840	3969.99
15	Channel	647168	656000	664832
	Frequency	3707.52	3840	3972.48
10	Channel	647000	656000	665000
	Frequency	3705	3840	3975



5G n78(30kHz) Channel and Frequency List				
BW [MHz]	Channel/Frequency(MHz)	Lowest	Middle	Highest
100	Channel	650000		
	Frequency	3750		
90	Channel	649668	650000	650332
	Frequency	3745.02	3750	3754.98
80	Channel	649334	650000	650666
	Frequency	3740.01	3750	3759.99
70	Channel	649000	650000	651000
	Frequency	3735	3750	3765
60	Channel	648668	650000	651332
	Frequency	3730.02	3750	3769.98
50	Channel	648334	650000	651666
	Frequency	3725.01	3750	3774.99
40	Channel	648000	650000	652000
	Frequency	3720	3750	3780
30	Channel	647668	650000	652332
	Frequency	3715.02	3750	3784.98
25	Channel	647500	650000	652500
	Frequency	3712.5	3750	3787.5
20	Channel	647334	650000	652666
	Frequency	3710.01	3750	3789.99
15	Channel	647168	650000	652832
	Frequency	3707.52	3750	3792.48
10	Channel	647000	650000	653000
	Frequency	3705	3750	3795

3 Conducted Test Items

3.1 Measuring Instruments

See list of measuring instruments of this test report.

3.2 Test Setup

3.2.1 Conducted Output Power

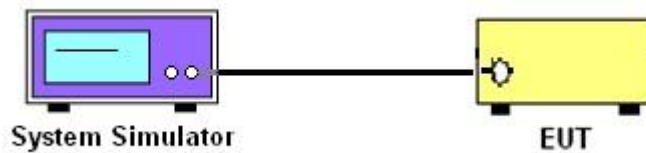

3.2.2 Peak-to-Average Ratio, Occupied Bandwidth, Conducted Band-Edge and Conducted Spurious Emission

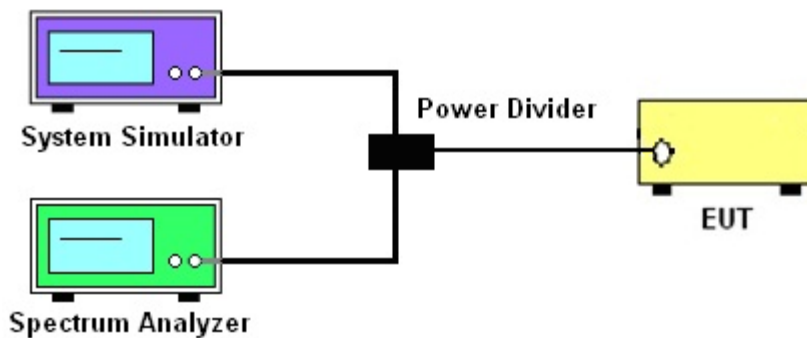

3.2.3 Frequency Stability

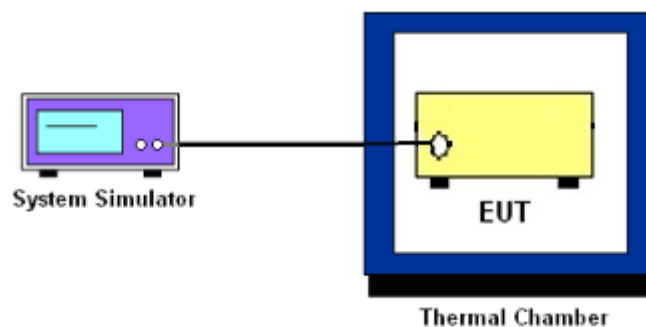

3.3 Test Result of Conducted Test

Please refer to Appendix A.



3.4 Conducted Output Power and EIRP

3.4.1 Description of the Conducted Output Power Measurement and EIRP Measurement

A system simulator was used to establish communication with the EUT. Its parameters were set to force the EUT transmitting at maximum output power. The measured power in the radio frequency on the transmitter output terminals shall be reported.

The EIRP of mobile transmitters must not exceed 1 Watts for 5G NR n77, n78.

According to KDB 412172 D01 Power Approach,

$EIRP = P_T + G_T - L_C$, $ERP = EIRP - 2.15$, where

P_T = transmitter output power in dBm

G_T = gain of the transmitting antenna in dBi

L_C = signal attenuation in the connecting cable between the transmitter and antenna in dB

3.4.2 Test Procedures

1. The testing follows ANSI C63.26 Section 5.2
2. The transmitter output port was connected to the system simulator.
3. Set EUT at maximum power through the system simulator.
4. Select lowest, middle, and highest channels for each band and different modulation.
5. Measure and record the power level from the system simulator.



3.5 Peak-to-Average Ratio

3.5.1 Description of the PAR Measurement

Power Complementary Cumulative Distribution Function (CCDF) curves provide a means for characterizing the power peaks of a digitally modulated signal on a statistical basis. A CCDF curve depicts the probability of the peak signal amplitude exceeding the average power level. Most contemporary measurement instrumentation include the capability to produce CCDF curves for an input signal provided that the instrument's resolution bandwidth can be set wide enough to accommodate the entire input signal bandwidth. In measuring transmissions in this band using an average power technique, the peak-to-average ratio (PAR) of the transmission may not exceed 13 dB.

3.5.2 Test Procedures

1. The testing follows ANSI C63.26 Section 5.2.3.4 (CCDF).
2. The EUT was connected to spectrum and system simulator via a power divider.
3. Set the CCDF (Complementary Cumulative Distribution Function) option in spectrum analyzer.
4. The highest RF powers were measured and recorded the maximum PAPR level associated with a probability of 0.1 %.
5. Record the deviation as Peak to Average Ratio.



3.6 Occupied Bandwidth

3.6.1 Description of Occupied Bandwidth Measurement

The occupied bandwidth is the width of a frequency band such that, below the lower and above the upper frequency limits, the mean powers emitted are each equal to a specified percentage 0.5% of the total mean transmitted power.

The 26 dB emission bandwidth is defined as the frequency range between two points, one above and one below the carrier frequency, at which the spectral density of the emission is attenuated 26 dB below the maximum in-band spectral density of the modulated signal. Spectral density (power per unit bandwidth) is to be measured with a detector of resolution bandwidth equal to approximately 1.0% of the emission bandwidth.

3.6.2 Test Procedures

1. The testing follows ANSI C63.26 Section 5.4
2. The EUT was connected to spectrum analyzer and system simulator via a power divider.
3. The spectrum analyzer center frequency is set to the nominal EUT channel center frequency. The span range for the spectrum analyzer shall be between two and five times the anticipated OBW.
4. The nominal resolution bandwidth (RBW) shall be in the range of 1 to 5 % of the anticipated OBW, and the VBW shall be at least 3 times the RBW.
5. Set the detection mode to peak, and the trace mode to max hold.
6. Determine the reference value: Set the EUT to transmit a modulated signal. Allow the trace to stabilize. Set the spectrum analyzer marker to the highest level of the displayed trace.
(this is the reference value)
7. Determine the “-26 dB down amplitude” as equal to (Reference Value – X).
8. Place two markers, one at the lowest and the other at the highest frequency of the envelope of the spectral display such that each marker is at or slightly below the “-X dB down amplitude” determined in step 6. If a marker is below this “-X dB down amplitude” value it shall be placed as close as possible to this value. The OBW is the positive frequency difference between the two markers.
9. Use the 99 % power bandwidth function of the spectrum analyzer and report the measured bandwidth.



3.7 Conducted Band Edge

3.7.1 Description of Conducted Band Edge Measurement

27.53(l)(2)

For mobile operations in the 3700-3980 MHz band, the conducted power of any emission outside the licensee's authorized bandwidth shall not exceed -13 dBm/MHz. Compliance with this paragraph is based on the use of measurement instrumentation employing a resolution bandwidth of 1 megahertz or greater. However, in the 1 megahertz bands immediately outside and adjacent to the licensee's frequency block, the minimum resolution bandwidth for the measurement shall be either one percent of the emission bandwidth of the fundamental emission of the transmitter or 350 kHz. In the bands between 1 and 5 MHz removed from the licensee's frequency block, the minimum resolution bandwidth for the measurement shall be 500 kHz.

3.7.2 Test Procedures

1. The testing follows ANSI C63.26 section 5.7
2. The EUT was connected to spectrum analyzer and system simulator via a power divider.
3. The band edges of low and high channels for the highest RF powers were measured.
4. Set RBW \geq 1% EBW in the 1MHz band immediately outside and adjacent to the band edge.
5. Beyond the 1 MHz band from the band edge, RBW=1MHz was used
6. Set spectrum analyzer with RMS detector.
7. The RF fundamental frequency should be excluded against the limit line in the operating frequency band.
8. Checked that all the results comply with the emission limit line.

Example:

$$\begin{aligned} & \text{The limit line is derived from } 43 + 10\log(P)\text{dB below the transmitter power } P(\text{Watts}) \\ & = P(\text{W}) - [43 + 10\log(P)] \text{ (dB)} \\ & = [30 + 10\log(P)] \text{ (dBm)} - [43 + 10\log(P)] \text{ (dB)} = -13\text{dBm}. \end{aligned}$$

9. When using the integration method, the starting frequency of the integration shall be centered at one-half of the RBW away from the band edge.



3.8 Conducted Spurious Emission

3.8.1 Description of Conducted Spurious Emission Measurement

The power of any emission outside of the authorized operating frequency ranges must be lower than the transmitter power (P) by a factor of at least $43 + 10 \log (P)$ dB.

It is measured by means of a calibrated spectrum analyzer and scanned from 30 MHz up to a frequency including its 10th harmonic.

3.8.2 Test Procedures

1. The testing follows ANSI C63.26 section 5.7
2. The EUT was connected to spectrum analyzer and system simulator via a power divider.
3. The RF output of EUT was connected to the spectrum analyzer by RF cable and attenuator. The path loss was compensated to the results for each measurement.
4. The middle channel for the highest RF power within the transmitting frequency was measured.
5. The conducted spurious emission for the whole frequency range was taken.
6. Make the measurement with the spectrum analyzer's RBW = 1MHz, VBW = 3MHz.
7. Set spectrum analyzer with RMS detector.
8. Taking the record of maximum spurious emission.
9. The RF fundamental frequency should be excluded against the limit line in the operating frequency band.
10. The limit line is derived from $43 + 10\log(P)$ dB below the transmitter power P(Watts)
= $P(W) - [43 + 10\log(P)]$ (dB)
= $[30 + 10\log(P)]$ (dBm) - $[43 + 10\log(P)]$ (dB)
= -13dBm.



3.9 Frequency Stability

3.9.1 Description of Frequency Stability Measurement

The frequency stability shall be measured by variation of ambient temperature and variation of primary supply voltage to ensure that the fundamental emission stays within the authorized frequency block. The frequency stability of the transmitter shall be maintained within $\pm 0.00025\%$ ($\pm 2.5\text{ppm}$) of the center frequency.

3.9.2 Test Procedures for Temperature Variation

1. The testing follows ANSI C63.26 section 5.6.4
2. The EUT was set up in the thermal chamber and connected with the system simulator.
3. With power OFF, the temperature was decreased to -30°C and the EUT was stabilized before testing. Power was applied and the maximum change in frequency was recorded within one minute.
4. With power OFF, the temperature was raised in 10°C step up to 50°C . The EUT was stabilized at each step for at least half an hour. Power was applied and the maximum frequency change was recorded within one minute.

3.9.3 Test Procedures for Voltage Variation

1. The testing follows ANSI C63.26 section 5.6.5
2. The EUT was placed in a temperature chamber at $20\pm 5^{\circ}\text{C}$ and connected with the system simulator.
3. The power supply voltage to the EUT was varied from 85% to 115% of the nominal value for other than hand carried battery equipment.
4. For hand carried, battery powered equipment, reduce the primary ac or dc supply voltage to the battery operating end point, which shall be specified by the manufacturer.
5. The variation in frequency was measured for the worst case.

4 Radiated Test Items

4.1 Measuring Instruments

See list of measuring instruments of this test report.

4.2 Test Setup

4.2.1 For radiated test below 30MHz

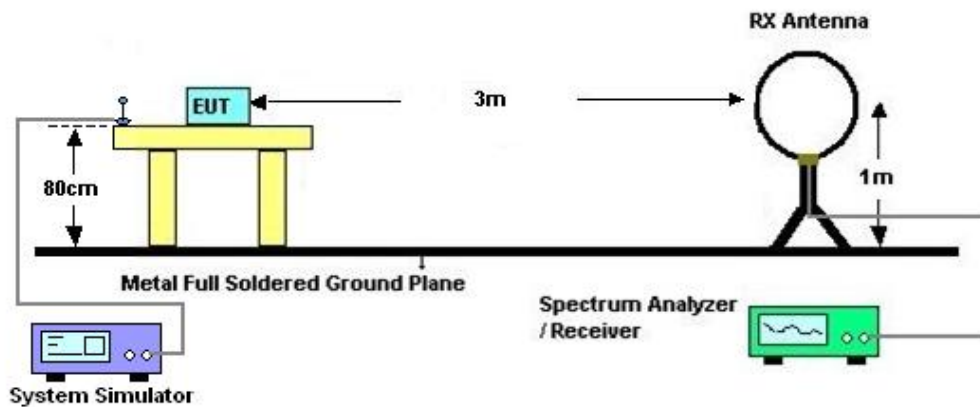

4.2.2 For radiated test from 30MHz to 1GHz

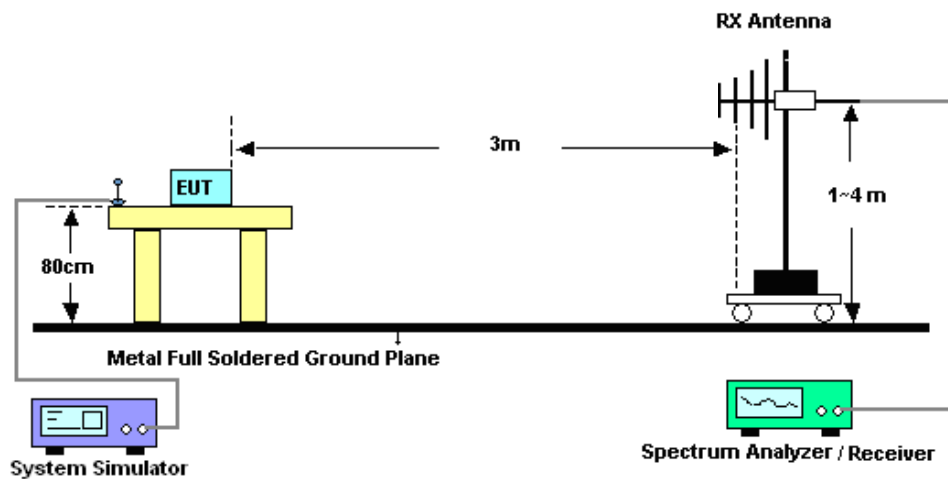

4.2.3 For radiated test above 1GHz

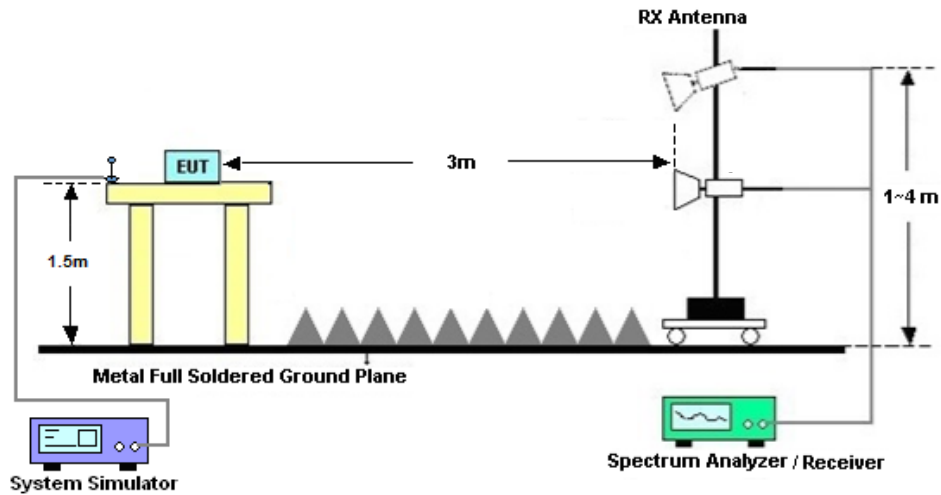

4.3 Test Result of Radiated Test

The low frequency, which started from 9 kHz to 30MHz, was pre-scanned and the result which was 20dB lower than the limit line was not reported.

Please refer to Appendix B.



4.4 Radiated Spurious Emission

4.4.1 Description of Radiated Spurious Emission

The radiated spurious emission was measured by substitution method according to ANSI C63.26. The power of any emission outside of the authorized operating frequency ranges must be attenuated below the transmitter power (P) by a factor of at least $43 + 10 \log (P)$ dB.

The spectrum is scanned from 30 MHz up to a frequency including its 10th harmonic.

4.4.2 Test Procedures

1. The testing follows ANSI C63.26 Section 5.5
2. The EUT was placed on a turntable with 0.8 meter height for frequency below 1GHz and 1.5 meter height for frequency above 1GHz respectively above ground.
3. The EUT was set 3 meters from the receiving antenna mounted on the antenna tower.
4. The table was rotated 360 degrees to determine the position of the highest spurious emission.
5. The height of the receiving antenna is varied between 1m to 4m to search the maximum spurious emission for both horizontal and vertical polarizations.
6. During the measurement, the system simulator parameters were set to force the EUT transmitting at maximum output power.
7. Make the measurement with the spectrum analyzer's RBW = 1MHz, VBW = 3MHz, taking the record of maximum spurious emission.
8. A horn antenna was substituted in place of the EUT and was driven by a signal generator.
9. Tune the output power of signal generator to the same emission level with EUT maximum spurious emission.
10. $EIRP (dBm) = S.G. Power - Tx Cable Loss + Tx Antenna Gain$
11. $ERP (dBm) = EIRP - 2.15$
12. The RF fundamental frequency should be excluded against the limit line in the operating frequency band.

The limit line is derived from $43 + 10\log(P)$ dB below the transmitter power P(Watts)
= $P(W) - [43 + 10\log(P)]$ (dB)
= $[30 + 10\log(P)]$ (dBm) - $[43 + 10\log(P)]$ (dB)
= -13dBm.



5 List of Measuring Equipment

Instrument	Manufacturer	Model No.	Serial No.	Characteristics	Calibration Date	Test Date	Due Date	Remark
Spectrum Analyzer	R&S	FSV40	101078	10Hz~40GHz	Apr. 08, 2022	Mar. 09, 2023~ Apr. 10, 2023	Apr. 07, 2023	Conducted (TH01-SZ)
Spectrum Analyzer	R&S	FSV40	101078	10Hz~40GHz	Apr. 06, 2023		Apr. 05, 2024	Conducted (TH01-SZ)
DC Power Supply	TTI	PL330P	290070	Max 32V , 3A	Oct. 17, 2022	Mar. 09, 2022~ Apr. 10, 2023	Oct. 16, 2023	Conducted (TH01-SZ)
Power Divider	TOJOIN	PS-2SM-04 265	60.06.020.007 7	0.4GHz~26.5GHz	Dec. 25, 2022	Mar. 09, 2022~ Apr. 10, 2023	Dec. 24, 2023	Conducted (TH01-SZ)
Thermal Chamber	Ten Billion Hongzhangroup	LP-150U	H2014081803	-40~+150°C	Jul. 07, 2022	Mar. 09, 2022~ Apr. 10, 2023	Jul. 06, 2023	Conducted (TH01-SZ)
EXA Spectrum Analyzer	Keysight	N9010B	MY57471079	10Hz-44G,MAX 30dB	Oct. 12, 2022	Mar. 29, 2023~ Mar. 30, 2023	Oct. 11, 2023	Radiation (03CH04-KS)
Loop Antenna	R&S	HFH2-Z2	100321	9kHz~30MHz	Oct. 30, 2021	Mar. 29, 2023~ Mar. 30, 2023	Oct. 29, 2022	Radiation (03CH04-KS)
Bilog Antenna	TeseQ	CBL6111D	49922	30MHz-1GHz	May 24, 2022	Mar. 29, 2023~ Mar. 30, 2023	May 23, 2023	Radiation (03CH04-KS)
Horn Antenna	Schwarzbeck	BBHA9120D	1284	1GHz~18GHz	Oct. 16, 2022	Mar. 29, 2023~ Mar. 30, 2023	Oct. 15, 2023	Radiation (03CH04-KS)
SHF-EHF Horn	Com-power	AH-840	101070	18GHz~40GHz	Jan. 08, 2023	Mar. 29, 2023~ Mar. 30, 2023	Jan. 07, 2024	Radiation (03CH04-KS)
Amplifier	SONOMA	310N	187289	9KHz-1GHz	May 24, 2022	Mar. 29, 2023~ Mar. 30, 2023	May 23, 2023	Radiation (03CH04-KS)
Amplifier	MITEQ	EM18G40G GA	060728	18~40GHz	Jan. 05, 2023	Mar. 29, 2023~ Mar. 30, 2023	Jan. 04, 2024	Radiation (03CH04-KS)
high gain Amplifier	EM	EM01G18G A	060840	1Ghz-18Ghz	Oct. 12, 2022	Mar. 29, 2023~ Mar. 30, 2023	Oct. 11, 2023	Radiation (03CH04-KS)
Amplifier	Agilent	8449B	3008A02370	1Ghz-18Ghz	Oct. 12, 2022	Mar. 29, 2023~ Mar. 30, 2023	Oct. 11, 2023	Radiation (03CH04-KS)
AC Power Source	Chroma	61601	F104090004	N/A	NCR	Mar. 29, 2023~ Mar. 30, 2023	NCR	Radiation (03CH04-KS)
Turn Table	ChamPro	EM 1000-T	060762-T	0~360 degree	NCR	Mar. 29, 2023~ Mar. 30, 2023	NCR	Radiation (03CH04-KS)
Antenna Mast	ChamPro	EM 1000-A	060762-A	1 m~4 m	NCR	Mar. 29, 2023~ Mar. 30, 2023	NCR	Radiation (03CH04-KS)

NCR: No Calibration Required.



6 Uncertainty of Evaluation

The measurement uncertainties shown below were calculated in accordance with the requirements of ANSI 63.26-2015. All the measurement uncertainty value were shown with a coverage K=2 to indicate 95% level of confidence. The measurement data show herein meets or exceeds the CISPR measurement uncertainty values specified in CISPR 16-4-2 and can be compared directly to specified limit to determine compliance.

Uncertainty of Conducted Measurement

Test Item	Uncertainty
Conducted Power	±1.34 dB
Conducted Emissions	±1.34 dB
Occupied Channel Bandwidth	±0.12 %

Uncertainty of Radiated Emission Measurement (30 MHz ~ 1000 MHz)

Measuring Uncertainty for a Level of Confidence of 95% (U = 2Uc(y))	3.3dB
---	-------

Uncertainty of Radiated Emission Measurement (1 GHz ~ 18 GHz)

Measuring Uncertainty for a Level of Confidence of 95% (U = 2Uc(y))	2.8dB
---	-------

Uncertainty of Radiated Emission Measurement (18 GHz ~ 40 GHz)

Measuring Uncertainty for a Level of Confidence of 95% (U = 2Uc(y))	2.8dB
---	-------

----- THE END -----



Appendix A. Test Results of Conducted Test

Test Engineer :	Jung Kuo	Temperature :	22~23°C
		Relative Humidity :	40~42%

FR1 N77-SCS 15K(ANT4)

Transmitter Conducted Output Power and EIRP, ($G_T - L_C$)=-8.8dB

NR Band	SCS (kHz)	Bandwidth (MHz)	Arfcn	Freq (MHz)	Modulation	RB	Conducted Power (dBm)	EIRP (dBm)	EIRP (W)
77	15	10	647000	3705	DFT-s-OFDM QPSK	1@1	25.82	17.02	0.0504
77	15	10	647000	3705	DFT-s-OFDM 16 QAM	1@1	25.25	16.45	0.0442
77	15	10	656000	3840	DFT-s-OFDM QPSK	1@1	25.86	17.06	0.0508
77	15	10	656000	3840	DFT-s-OFDM 16 QAM	1@1	25.08	16.28	0.0425
77	15	10	665000	3975	DFT-s-OFDM QPSK	1@1	25.85	17.05	0.0507
77	15	10	665000	3975	DFT-s-OFDM 16 QAM	1@1	25.13	16.33	0.0430
77	15	15	647167	3707.505	DFT-s-OFDM QPSK	1@1	25.93	17.13	0.0516
77	15	15	647167	3707.505	DFT-s-OFDM 16 QAM	1@1	25.08	16.28	0.0425
77	15	15	656000	3840	DFT-s-OFDM QPSK	1@1	25.97	17.17	0.0521
77	15	15	656000	3840	DFT-s-OFDM 16 QAM	1@1	25.16	16.36	0.0433
77	15	15	664833	3972.495	DFT-s-OFDM QPSK	1@1	25.76	16.96	0.0497
77	15	15	664833	3972.495	DFT-s-OFDM 16 QAM	1@1	24.96	16.16	0.0413
77	15	20	647334	3710.01	DFT-s-OFDM QPSK	1@1	25.87	17.07	0.0509
77	15	20	647334	3710.01	DFT-s-OFDM 16 QAM	1@1	25.08	16.28	0.0425
77	15	20	656000	3840	DFT-s-OFDM QPSK	1@1	26.09	17.29	0.0536
77	15	20	656000	3840	DFT-s-OFDM 16 QAM	1@1	25.22	16.42	0.0439
77	15	20	664666	3969.99	DFT-s-OFDM QPSK	1@1	25.82	17.02	0.0504
77	15	20	664666	3969.99	DFT-s-OFDM 16 QAM	1@1	24.93	16.13	0.0410
77	15	25	647500	3712.5	DFT-s-OFDM QPSK	1@1	25.83	17.03	0.0505
77	15	25	647500	3712.5	DFT-s-OFDM 16 QAM	1@1	25.07	16.27	0.0424
77	15	25	656000	3840	DFT-s-OFDM QPSK	1@1	25.9	17.1	0.0513
77	15	25	656000	3840	DFT-s-OFDM 16 QAM	1@1	25.19	16.39	0.0436
77	15	25	664500	3967.5	DFT-s-OFDM QPSK	1@1	25.54	16.74	0.0472
77	15	25	664500	3967.5	DFT-s-OFDM 16 QAM	1@1	24.69	15.89	0.0388
77	15	30	647667	3715.005	DFT-s-OFDM QPSK	1@1	25.8	17	0.0501
77	15	30	647667	3715.005	DFT-s-OFDM 16 QAM	1@1	25.03	16.23	0.0420
77	15	30	656000	3840	DFT-s-OFDM QPSK	1@1	25.97	17.17	0.0521
77	15	30	656000	3840	DFT-s-OFDM 16 QAM	1@1	25.24	16.44	0.0441
77	15	30	664332	3964.98	DFT-s-OFDM QPSK	1@1	25.49	16.69	0.0467

77	15	30	664332	3964.98	DFT-s-OFDM 16 QAM	1@1	24.66	15.86	0.0385
77	15	40	648000	3720	DFT-s-OFDM QPSK	1@1	25.84	17.04	0.0506
77	15	40	648000	3720	DFT-s-OFDM 16 QAM	1@1	24.97	16.17	0.0414
77	15	40	656000	3840	DFT-s-OFDM QPSK	1@1	26.07	17.27	0.0533
77	15	40	656000	3840	DFT-s-OFDM 16 QAM	1@1	25.26	16.46	0.0443
77	15	40	664000	3960	DFT-s-OFDM QPSK	1@1	25.48	16.68	0.0466
77	15	40	664000	3960	DFT-s-OFDM 16 QAM	1@1	24.65	15.85	0.0385
77	15	50	648334	3725.01	DFT-s-OFDM PI/2 BPSK	135@67	25.84	17.04	0.0506
77	15	50	648334	3725.01	DFT-s-OFDM PI/2 BPSK	1@1	25.81	17.01	0.0502
77	15	50	648334	3725.01	DFT-s-OFDM PI/2 BPSK	1@268	25.78	16.98	0.0499
77	15	50	648334	3725.01	DFT-s-OFDM QPSK	135@67	25.87	17.07	0.0509
77	15	50	648334	3725.01	DFT-s-OFDM QPSK	1@1	25.75	16.95	0.0495
77	15	50	648334	3725.01	DFT-s-OFDM QPSK	1@268	25.82	17.02	0.0504
77	15	50	648334	3725.01	DFT-s-OFDM 16 QAM	135@67	24.85	16.05	0.0403
77	15	50	648334	3725.01	DFT-s-OFDM 16 QAM	1@1	25	16.2	0.0417
77	15	50	648334	3725.01	DFT-s-OFDM 16 QAM	1@268	24.98	16.18	0.0415
77	15	50	648334	3725.01	DFT-s-OFDM 64 QAM	135@67	23.31	14.51	0.0282
77	15	50	648334	3725.01	DFT-s-OFDM 64 QAM	1@1	23.41	14.61	0.0289
77	15	50	648334	3725.01	DFT-s-OFDM 64 QAM	1@268	23.48	14.68	0.0294
77	15	50	648334	3725.01	DFT-s-OFDM 256 QAM	135@67	21.41	12.61	0.0182
77	15	50	648334	3725.01	DFT-s-OFDM 256 QAM	1@1	21.41	12.61	0.0182
77	15	50	648334	3725.01	DFT-s-OFDM 256 QAM	1@268	21.42	12.62	0.0183
77	15	50	648334	3725.01	CP-OFDM QPSK	135@67	24.36	15.56	0.0360
77	15	50	648334	3725.01	CP-OFDM QPSK	1@1	24.25	15.45	0.0351
77	15	50	648334	3725.01	CP-OFDM QPSK	1@268	24.45	15.65	0.0367
77	15	50	656000	3840	DFT-s-OFDM PI/2 BPSK	135@67	25.78	16.98	0.0499
77	15	50	656000	3840	DFT-s-OFDM PI/2 BPSK	1@1	26.25	17.45	0.0556
77	15	50	656000	3840	DFT-s-OFDM PI/2 BPSK	1@268	25.37	16.57	0.0454
77	15	50	656000	3840	DFT-s-OFDM QPSK	135@67	25.79	16.99	0.0500
77	15	50	656000	3840	DFT-s-OFDM QPSK	1@1	26.1	17.3	0.0537
77	15	50	656000	3840	DFT-s-OFDM QPSK	1@268	25.41	16.61	0.0458
77	15	50	656000	3840	DFT-s-OFDM 16 QAM	135@67	24.82	16.02	0.0400
77	15	50	656000	3840	DFT-s-OFDM 16 QAM	1@1	25.35	16.55	0.0452
77	15	50	656000	3840	DFT-s-OFDM 16 QAM	1@268	24.6	15.8	0.0380
77	15	50	656000	3840	DFT-s-OFDM 64 QAM	135@67	23.32	14.52	0.0283

77	15	50	656000	3840	DFT-s-OFDM 64 QAM	1@1	23.65	14.85	0.0305
77	15	50	656000	3840	DFT-s-OFDM 64 QAM	1@268	22.98	14.18	0.0262
77	15	50	656000	3840	DFT-s-OFDM 256 QAM	135@67	21.31	12.51	0.0178
77	15	50	656000	3840	DFT-s-OFDM 256 QAM	1@1	21.73	12.93	0.0196
77	15	50	656000	3840	DFT-s-OFDM 256 QAM	1@268	21.01	12.21	0.0166
77	15	50	656000	3840	CP-OFDM QPSK	135@67	24.3	15.5	0.0355
77	15	50	656000	3840	CP-OFDM QPSK	1@1	24.64	15.84	0.0384
77	15	50	656000	3840	CP-OFDM QPSK	1@268	24.09	15.29	0.0338
77	15	50	663666	3954.99	DFT-s-OFDM PI/2 BPSK	135@67	25.58	16.78	0.0476
77	15	50	663666	3954.99	DFT-s-OFDM PI/2 BPSK	1@1	25.42	16.62	0.0459
77	15	50	663666	3954.99	DFT-s-OFDM PI/2 BPSK	1@268	25.82	17.02	0.0504
77	15	50	663666	3954.99	DFT-s-OFDM QPSK	135@67	25.55	16.75	0.0473
77	15	50	663666	3954.99	DFT-s-OFDM QPSK	1@1	25.41	16.61	0.0458
77	15	50	663666	3954.99	DFT-s-OFDM QPSK	1@268	25.89	17.09	0.0512
77	15	50	663666	3954.99	DFT-s-OFDM 16 QAM	135@67	24.62	15.82	0.0382
77	15	50	663666	3954.99	DFT-s-OFDM 16 QAM	1@1	24.6	15.8	0.0380
77	15	50	663666	3954.99	DFT-s-OFDM 16 QAM	1@268	25.11	16.31	0.0428
77	15	50	663666	3954.99	DFT-s-OFDM 64 QAM	135@67	23.08	14.28	0.0268
77	15	50	663666	3954.99	DFT-s-OFDM 64 QAM	1@1	23.13	14.33	0.0271
77	15	50	663666	3954.99	DFT-s-OFDM 64 QAM	1@268	23.47	14.67	0.0293
77	15	50	663666	3954.99	DFT-s-OFDM 256 QAM	135@67	21.14	12.34	0.0171
77	15	50	663666	3954.99	DFT-s-OFDM 256 QAM	1@1	20.95	12.15	0.0164
77	15	50	663666	3954.99	DFT-s-OFDM 256 QAM	1@268	21.53	12.73	0.0187
77	15	50	663666	3954.99	CP-OFDM QPSK	135@67	24.05	15.25	0.0335
77	15	50	663666	3954.99	CP-OFDM QPSK	1@1	23.91	15.11	0.0324
77	15	50	663666	3954.99	CP-OFDM QPSK	1@268	24.54	15.74	0.0375

Frequency Stability

NR Band	SCS (kHz)	Bandwidth (MHz)	Arfcn	Freq (MHz)	Modulation	RB	Deviation (ppm)	Verdict	Environment
77	15	20	656000	3840.0	DFT-s-OFDM QPSK	100@0	0.0034	PASS	NV
77	15	20	656000	3840.0	DFT-s-OFDM QPSK	100@0	0.0066	PASS	LV
77	15	20	656000	3840.0	DFT-s-OFDM QPSK	100@0	0.0045	PASS	HV
77	15	20	656000	3840.0	DFT-s-OFDM QPSK	100@0	0.0041	PASS	-30°C
77	15	20	656000	3840.0	DFT-s-OFDM QPSK	100@0	0.0021	PASS	-20°C
77	15	20	656000	3840.0	DFT-s-OFDM QPSK	100@0	0.0023	PASS	-10°C
77	15	20	656000	3840.0	DFT-s-OFDM QPSK	100@0	0.0061	PASS	0°C
77	15	20	656000	3840.0	DFT-s-OFDM QPSK	100@0	0.0059	PASS	10°C
77	15	20	656000	3840.0	DFT-s-OFDM QPSK	100@0	0.0034	PASS	20°C
77	15	20	656000	3840.0	DFT-s-OFDM QPSK	100@0	0.0039	PASS	30°C
77	15	20	656000	3840.0	DFT-s-OFDM QPSK	100@0	0.0038	PASS	40°C
77	15	20	656000	3840.0	DFT-s-OFDM QPSK	100@0	0.0070	PASS	50°C

Peak to Average Ratio

NR Band	SCS (kHz)	Bandwidth (MHz)	Arfcn	Freq (MHz)	Modulation	RB	Result (dB)	Limit (dB)	Verdict
77	15	20	647334	3710.01	DFT-s-OFDM PI/2 BPSK	100@0	4.24	13	PASS
77	15	20	647334	3710.01	DFT-s-OFDM PI/2 BPSK	1@0	5.55	13	PASS
77	15	20	647334	3710.01	DFT-s-OFDM QPSK	100@0	5.58	13	PASS
77	15	20	647334	3710.01	DFT-s-OFDM QPSK	1@0	6.28	13	PASS
77	15	20	656000	3840.0	DFT-s-OFDM PI/2 BPSK	100@0	4.3	13	PASS
77	15	20	656000	3840.0	DFT-s-OFDM PI/2 BPSK	1@0	4.82	13	PASS
77	15	20	656000	3840.0	DFT-s-OFDM QPSK	100@0	5.63	13	PASS
77	15	20	656000	3840.0	DFT-s-OFDM QPSK	1@0	6.29	13	PASS
77	15	20	664666	3969.99	DFT-s-OFDM PI/2 BPSK	100@0	4.37	13	PASS
77	15	20	664666	3969.99	DFT-s-OFDM PI/2 BPSK	1@0	4.52	13	PASS
77	15	20	664666	3969.99	DFT-s-OFDM QPSK	100@0	5.61	13	PASS
77	15	20	664666	3969.99	DFT-s-OFDM QPSK	1@0	6.07	13	PASS

N77(20M)_DFT-s-OFDM_PI_2-BPSK_Outer_Full_Low_CH

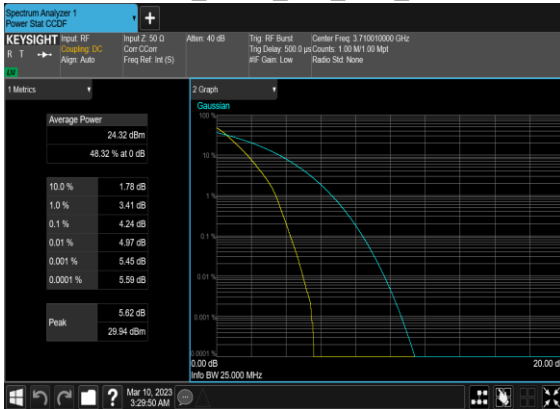

N77(20M)_DFT-s-OFDM_PI_2-BPSK_Edge_1RB_Left_Low_CH

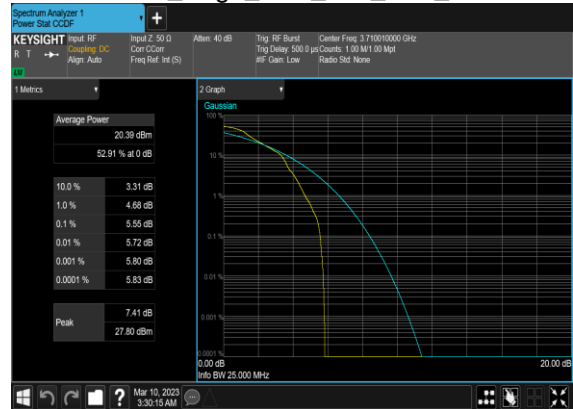

N77(20M)_DFT-s-OFDM_QPSK_Outer_Full_Low_CH

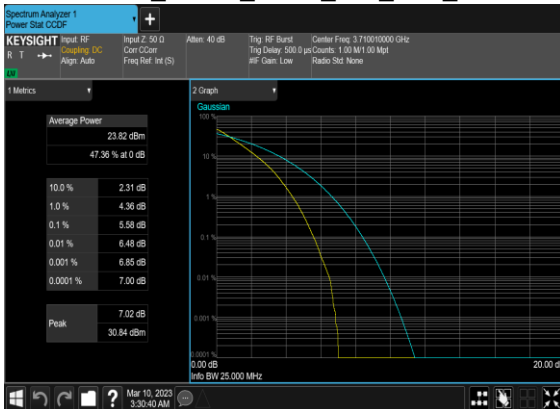

N77(20M)_DFT-s-OFDM_QPSK_Edge_1RB_Left_Low_CH

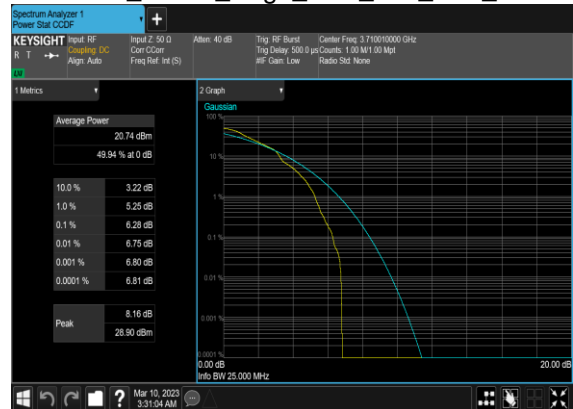

N77(20M)_DFT-s-OFDM_PI_2-BPSK_Outer_Full_Mid_CH

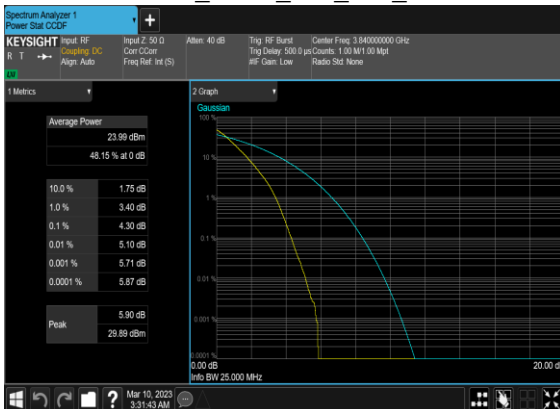

N77(20M)_DFT-s-OFDM_PI_2-BPSK_Edge_1RB_Left_Mid_CH

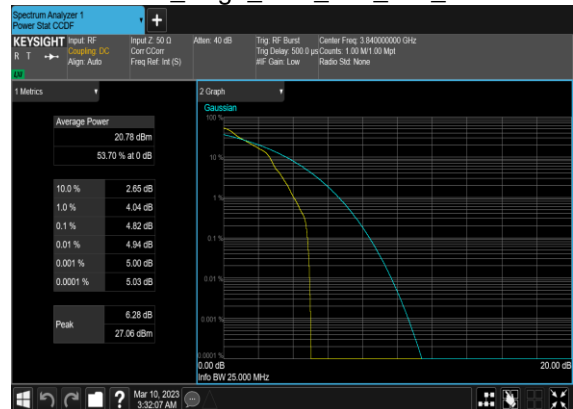

N77(20M)_DFT-s-OFDM_QPSK_Outer_Full_Mid_CH

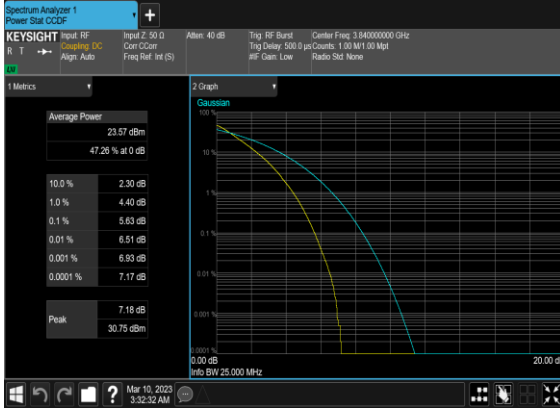

N77(20M)_DFT-s-OFDM_QPSK_Edge_1RB_Left_Mid_CH

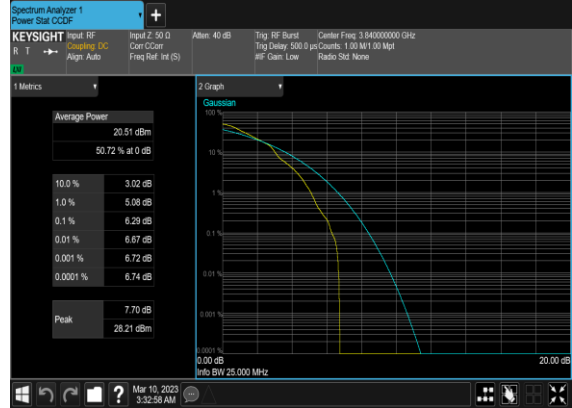

N77(20M)_DFT-s-OFDM_PI_2-BPSK_Outer_Full_High_CH

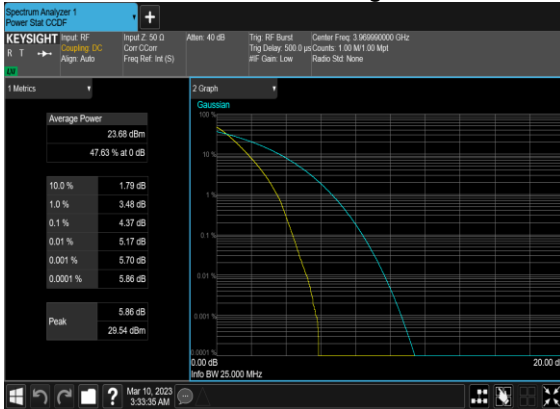

N77(20M)_DFT-s-OFDM_PI_2-BPSK_Edge_1RB_Left_High_CH

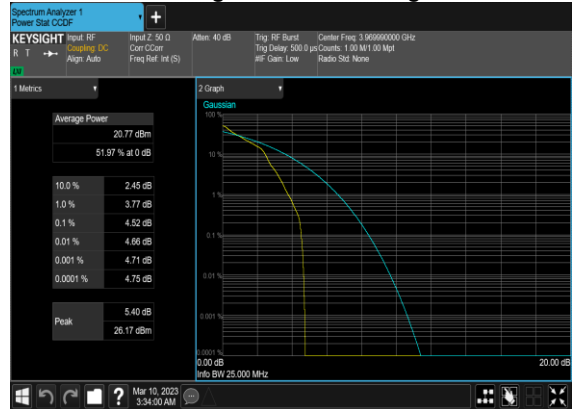

N77(20M)_DFT-s-OFDM_QPSK_Outer_Full_High_CH

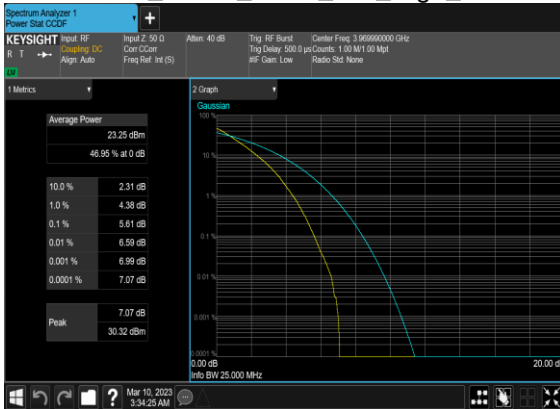

N77(20M)_DFT-s-OFDM_QPSK_Edge_1RB_Left_High_CH



Occupied Bandwidth

NR Band	SCS (kHz)	Bandwidth (MHz)	Arfcn	Freq (MHz)	Modulation	RB	OBW (MHz)	26dB BW (MHz)
77	15	10	656000	3840.0	DFT-s-OFDM PI/2 BPSK	50@0	8.9364	9.272
77	15	10	656000	3840.0	DFT-s-OFDM QPSK	50@0	8.9058	9.252
77	15	10	656000	3840.0	CP-OFDM QPSK	52@0	9.2647	9.702
77	15	10	656000	3840.0	CP-OFDM 16 QAM	52@0	9.2526	9.625
77	15	10	656000	3840.0	CP-OFDM 64 QAM	52@0	9.3013	9.761
77	15	10	656000	3840.0	CP-OFDM 256 QAM	52@0	9.275	9.639
77	15	15	656000	3840.0	DFT-s-OFDM PI/2 BPSK	75@0	13.317	13.98
77	15	15	656000	3840.0	DFT-s-OFDM QPSK	75@0	13.329	13.88
77	15	15	656000	3840.0	CP-OFDM QPSK	79@0	14.013	14.65
77	15	15	656000	3840.0	CP-OFDM 16 QAM	79@0	14.089	15.0
77	15	15	656000	3840.0	CP-OFDM 64 QAM	79@0	14.111	14.78
77	15	15	656000	3840.0	CP-OFDM 256 QAM	79@0	14.056	15.0
77	15	20	656000	3840.0	DFT-s-OFDM PI/2 BPSK	100@0	17.86	18.51
77	15	20	656000	3840.0	DFT-s-OFDM QPSK	100@0	17.85	18.48
77	15	20	656000	3840.0	CP-OFDM QPSK	106@0	18.898	19.54
77	15	20	656000	3840.0	CP-OFDM 16 QAM	106@0	18.883	19.59
77	15	20	656000	3840.0	CP-OFDM 64 QAM	106@0	18.922	19.56
77	15	20	656000	3840.0	CP-OFDM 256 QAM	106@0	18.933	19.65
77	15	25	656000	3840.0	DFT-s-OFDM PI/2 BPSK	128@0	22.827	23.67
77	15	25	656000	3840.0	DFT-s-OFDM QPSK	128@0	22.901	23.66
77	15	25	656000	3840.0	CP-OFDM QPSK	133@0	23.747	24.51
77	15	25	656000	3840.0	CP-OFDM 16 QAM	133@0	23.72	24.52
77	15	25	656000	3840.0	CP-OFDM 64 QAM	133@0	23.71	24.46
77	15	25	656000	3840.0	CP-OFDM 256 QAM	133@0	23.754	24.53
77	15	30	656000	3840.0	DFT-s-OFDM PI/2 BPSK	160@0	28.552	29.59
77	15	30	656000	3840.0	DFT-s-OFDM QPSK	160@0	28.522	29.62
77	15	30	656000	3840.0	CP-OFDM QPSK	160@0	28.503	29.48
77	15	30	656000	3840.0	CP-OFDM 16 QAM	160@0	28.56	29.52
77	15	30	656000	3840.0	CP-OFDM 64 QAM	160@0	28.645	29.47
77	15	30	656000	3840.0	CP-OFDM 256 QAM	160@0	28.551	29.49
77	15	40	656000	3840.0	DFT-s-OFDM PI/2 BPSK	216@0	38.518	39.88
77	15	40	656000	3840.0	DFT-s-OFDM QPSK	216@0	38.601	39.79
77	15	40	656000	3840.0	CP-OFDM QPSK	216@0	38.654	39.9

77	15	40	656000	3840.0	CP-OFDM 16 QAM	216@0	38.554	39.8
77	15	40	656000	3840.0	CP-OFDM 64 QAM	216@0	38.657	39.88
77	15	40	656000	3840.0	CP-OFDM 256 QAM	216@0	38.54	39.83
77	15	50	656000	3840.0	DFT-s-OFDM PI/2 BPSK	270@0	48.225	49.77
77	15	50	656000	3840.0	DFT-s-OFDM QPSK	270@0	48.222	50.21
77	15	50	656000	3840.0	CP-OFDM QPSK	270@0	48.163	49.7
77	15	50	656000	3840.0	CP-OFDM 16 QAM	270@0	48.041	49.75
77	15	50	656000	3840.0	CP-OFDM 64 QAM	270@0	48.14	49.7
77	15	50	656000	3840.0	CP-OFDM 256 QAM	270@0	48.238	50.3

N77(10M)_DFT-s-OFDM_PI_2-
BPSK_Outer_Full_Mid_CH

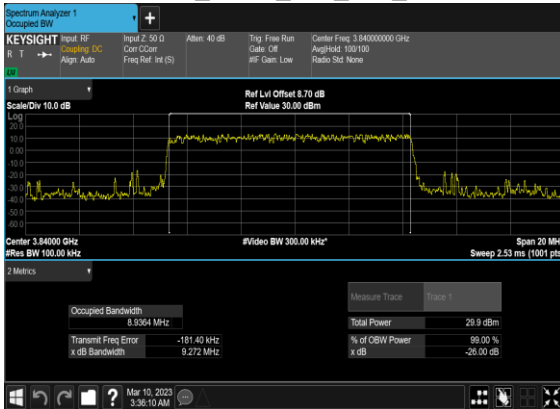

N77(10M)_DFT-s-
OFDM_QPSK_Outer_Full_Mid_CH

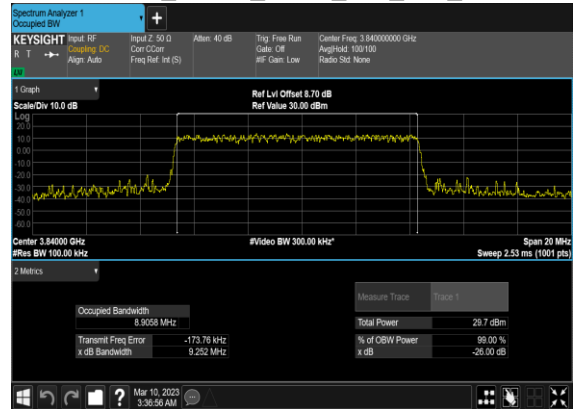

N77(10M)_CP-
OFDM_QPSK_Outer_Full_Mid_CH



N77(10M)_CP-OFDM_16
QAM_Outer_Full_Mid_CH



N77(10M)_CP-OFDM_64
QAM_Outer_Full_Mid_CH

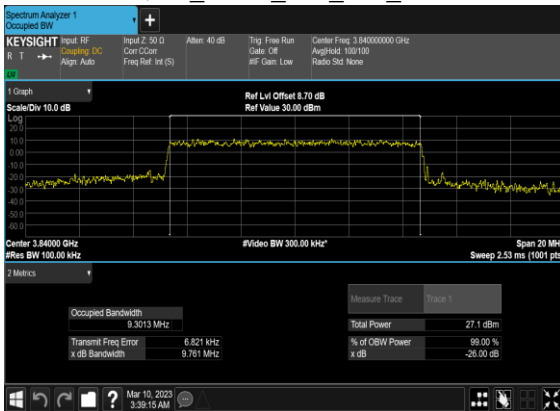

N77(10M)_CP-OFDM_256
QAM_Outer_Full_Mid_CH

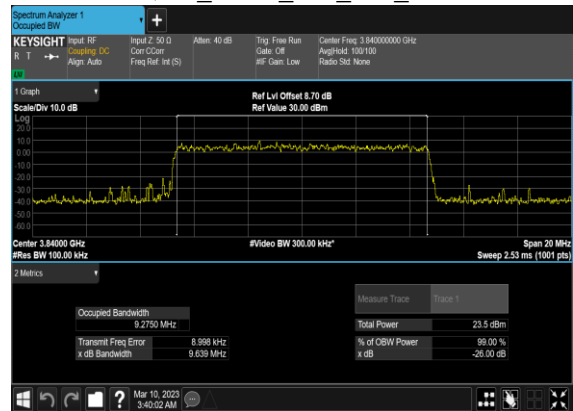

N77(15M)_DFT-s-OFDM_PI_2- BPSK_Outer_Full_Mid_CH

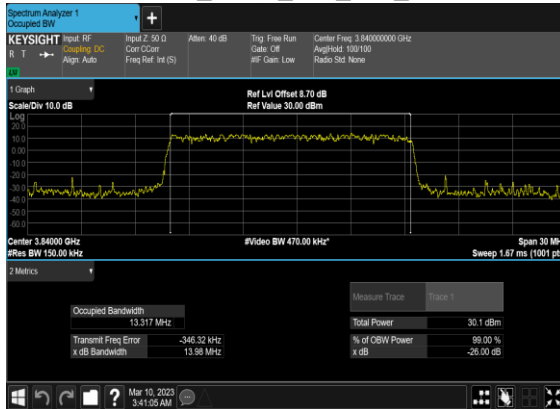

N77(15M)_DFT-s- OFDM_QPSK_Outer_Full_Mid_CH

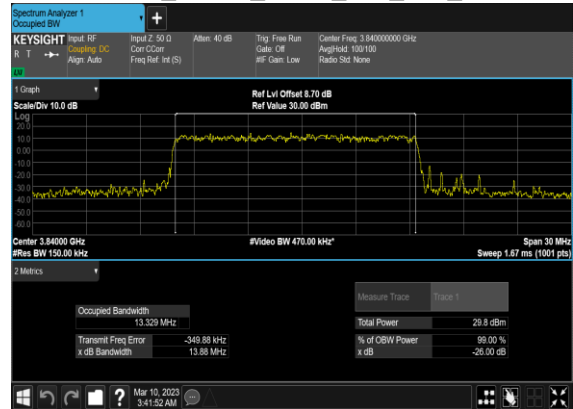

N77(15M)_CP- OFDM_QPSK_Outer_Full_Mid_CH

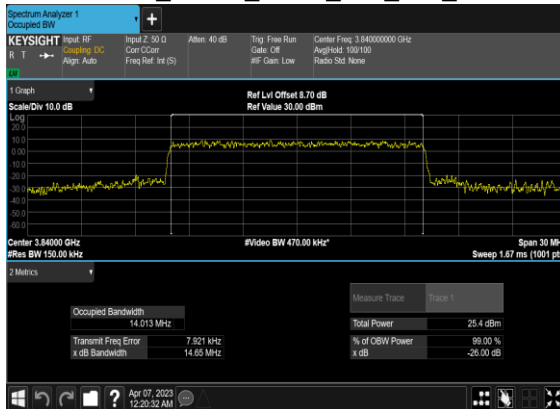

N77(15M)_CP-OFDM_16 QAM_Outer_Full_Mid_CH

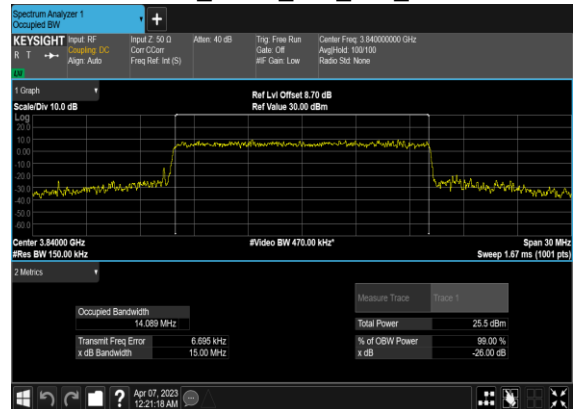

N77(15M)_CP-OFDM_64 QAM_Outer_Full_Mid_CH

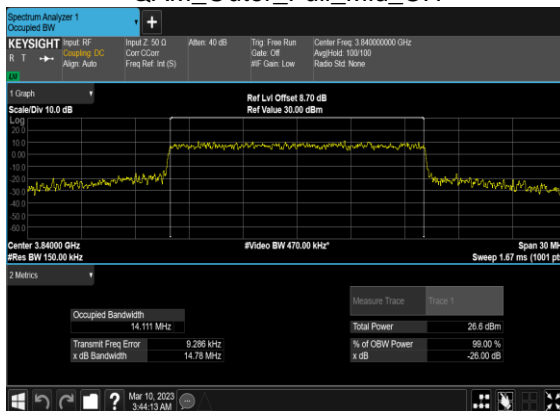

N77(15M)_CP-OFDM_256 QAM_Outer_Full_Mid_CH

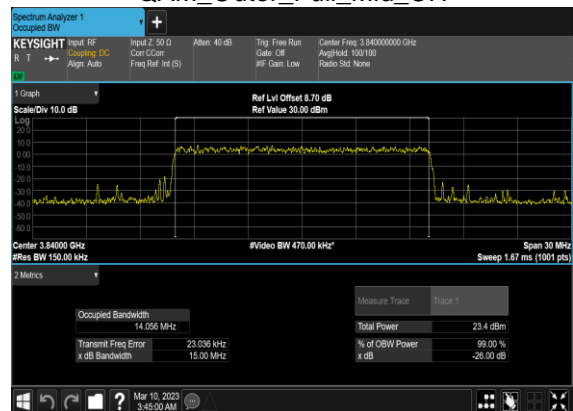

N77(20M)_DFT-s-OFDM_PI_2-
BPSK_Outer_Full_Mid_CH

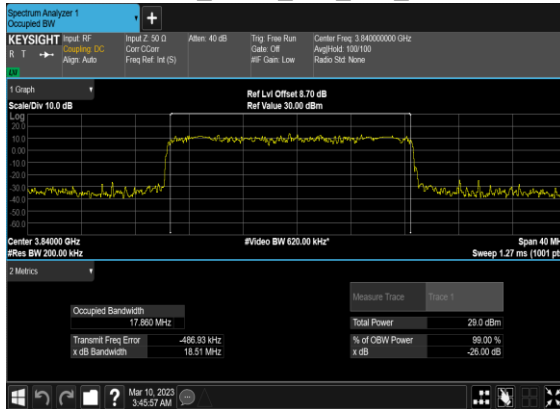

N77(20M)_DFT-s-
OFDM_QPSK_Outer_Full_Mid_CH

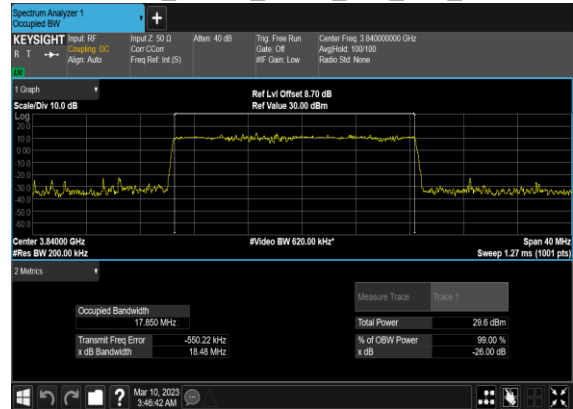

N77(20M)_CP-
OFDM_QPSK_Outer_Full_Mid_CH

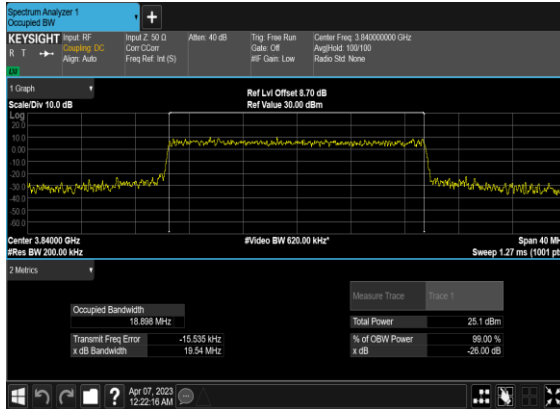

N77(20M)_CP-OFDM_16
QAM_Outer_Full_Mid_CH

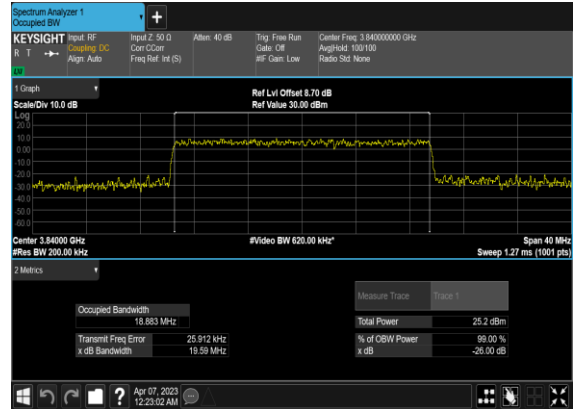

N77(20M)_CP-OFDM_64
QAM_Outer_Full_Mid_CH

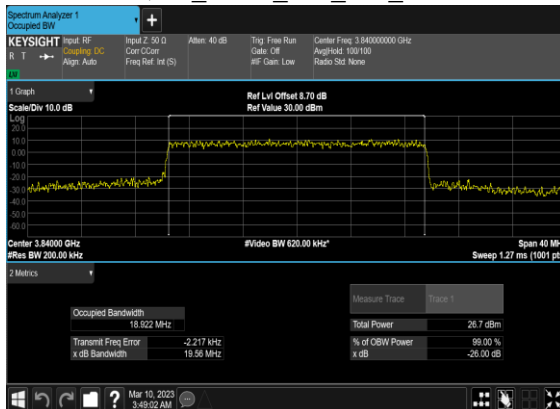

N77(20M)_CP-OFDM_256
QAM_Outer_Full_Mid_CH

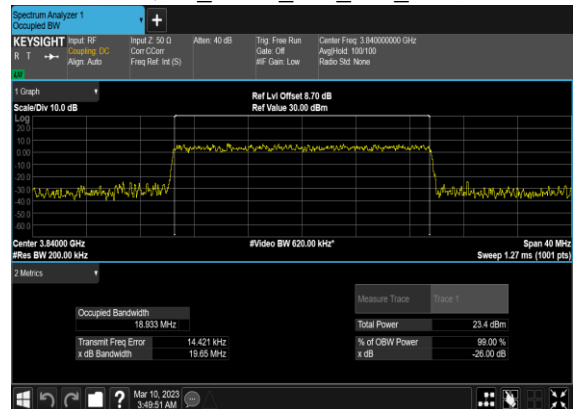

N77(25M)_DFT-s-OFDM_PI_2-
BPSK_Outer_Full_Mid_CH

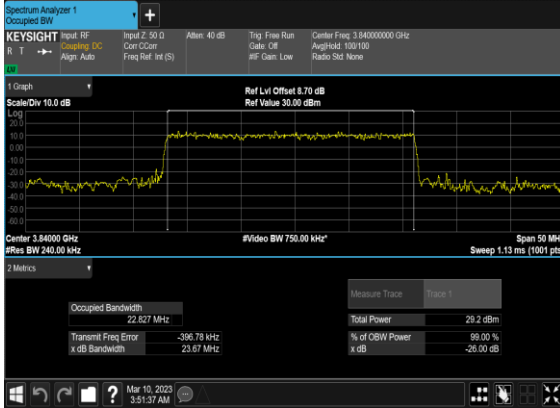

N77(25M)_DFT-s-
OFDM_QPSK_Outer_Full_Mid_CH

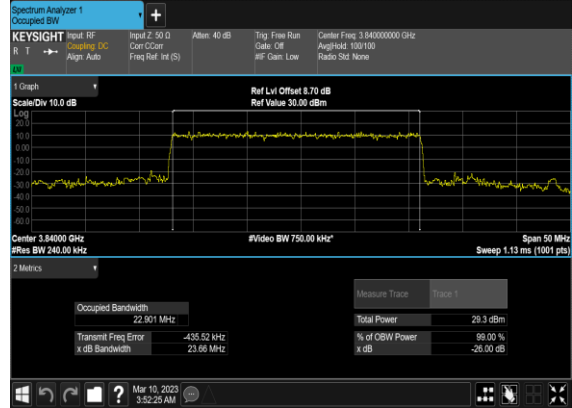

N77(25M)_CP-
OFDM_QPSK_Outer_Full_Mid_CH



N77(25M)_CP-OFDM_16
QAM_Outer_Full_Mid_CH

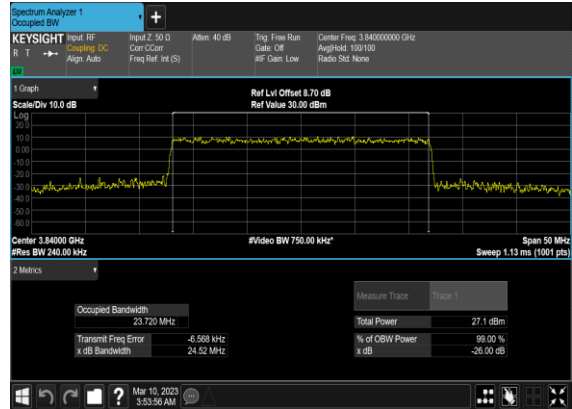

N77(25M)_CP-OFDM_64
QAM_Outer_Full_Mid_CH

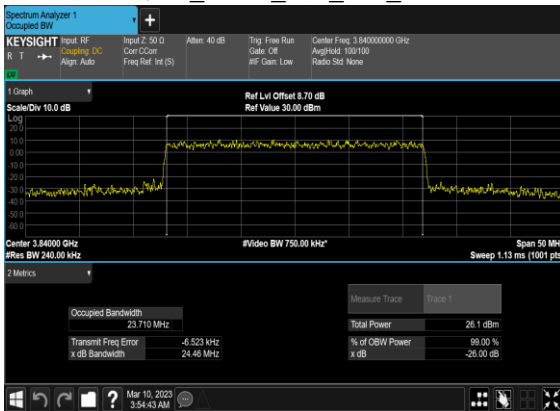

N77(25M)_CP-OFDM_256
QAM_Outer_Full_Mid_CH

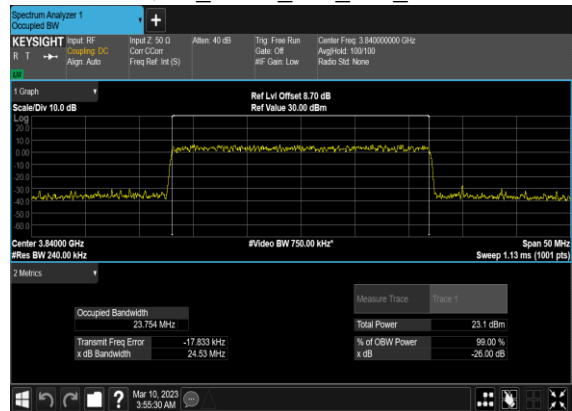

N77(30M)_DFT-s-OFDM_PI_2-BPSK_Outer_Full_Mid_CH

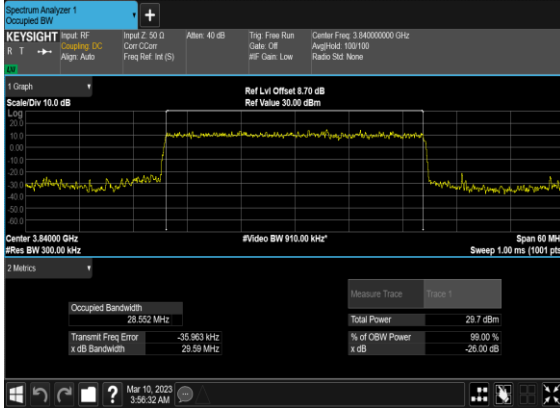

N77(30M)_DFT-s-OFDM_QPSK_Outer_Full_Mid_CH

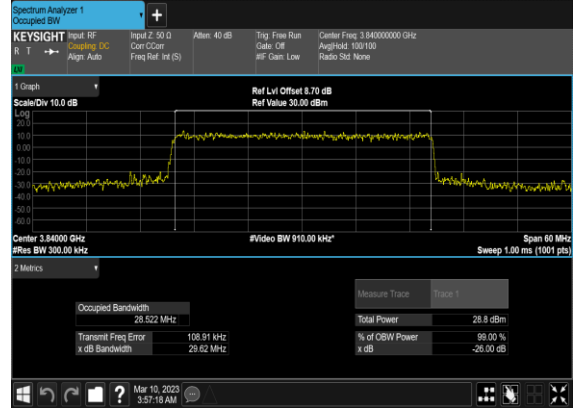

N77(30M)_CP-OFDM_QPSK_Outer_Full_Mid_CH

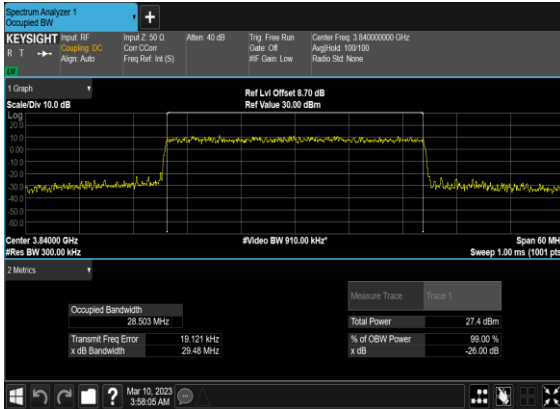

N77(30M)_CP-OFDM_16QAM_Outer_Full_Mid_CH

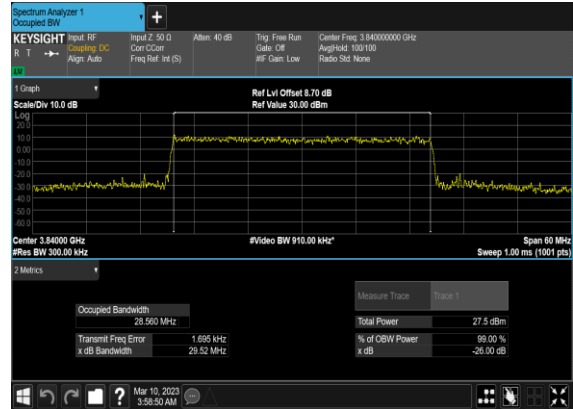

N77(30M)_CP-OFDM_64QAM_Outer_Full_Mid_CH

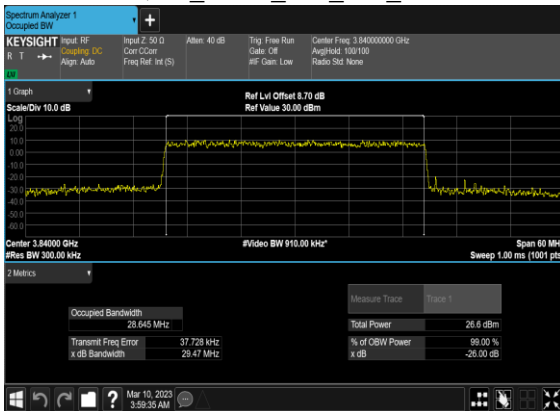

N77(30M)_CP-OFDM_256QAM_Outer_Full_Mid_CH

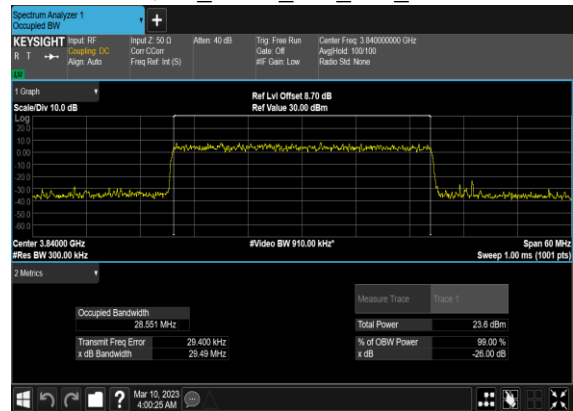

N77(50M)_DFT-s-OFDM_PI_2- BPSK_Outer_Full_Mid_CH

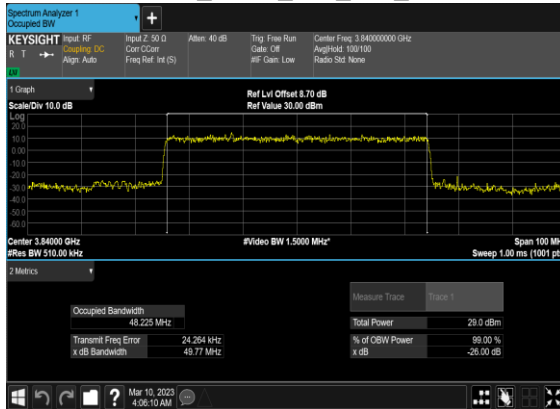

N77(50M)_DFT-s- OFDM_QPSK_Outer_Full_Mid_CH

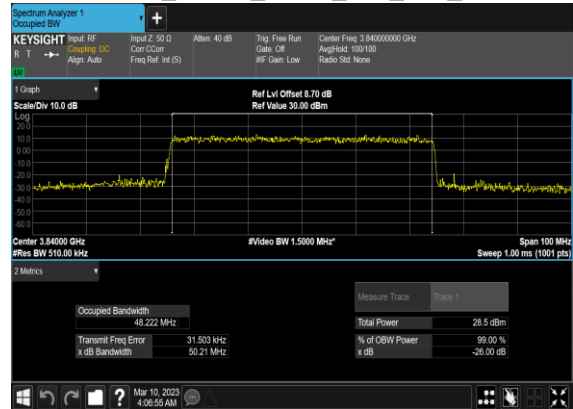

N77(50M)_CP- OFDM_QPSK_Outer_Full_Mid_CH

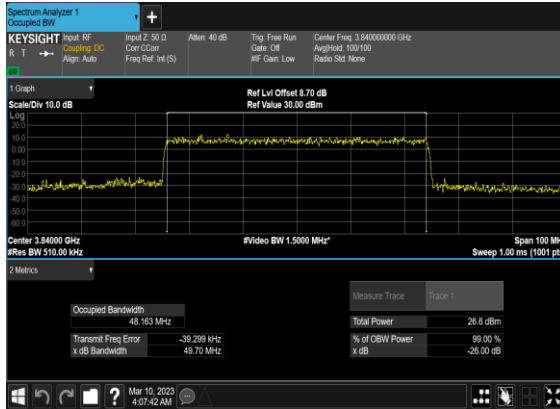

N77(50M)_CP-OFDM_16 QAM_Outer_Full_Mid_CH

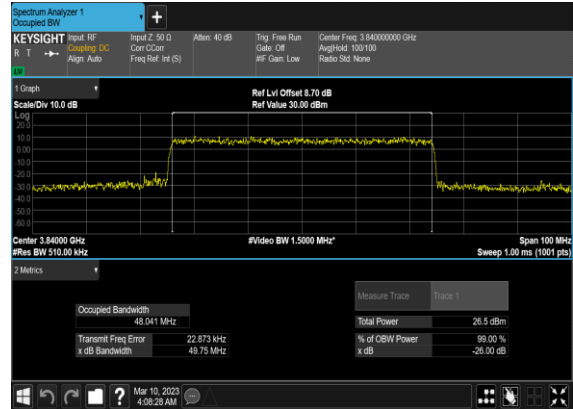

N77(50M)_CP-OFDM_64 QAM_Outer_Full_Mid_CH

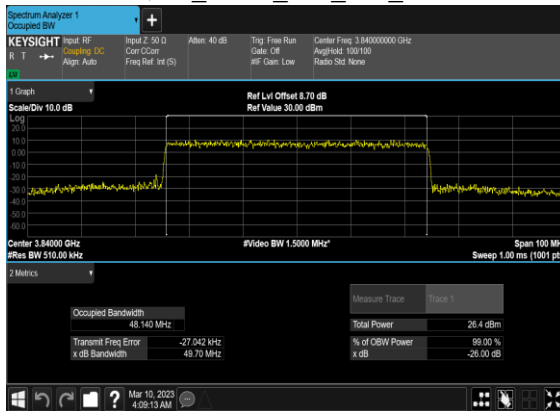

N77(50M)_CP-OFDM_256 QAM_Outer_Full_Mid_CH

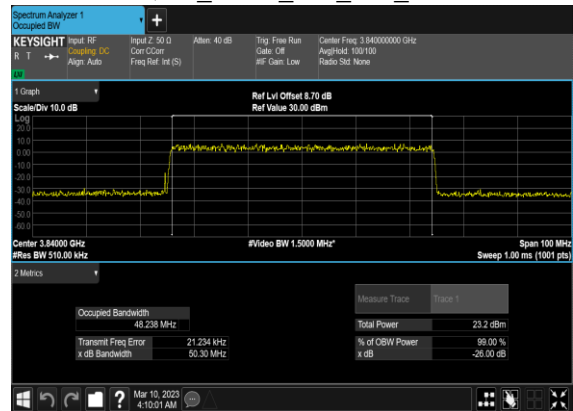

Conducted Spurious Emissions

NR Band	SCS (kHz)	Bandwidth (MHz)	Arfcn	Freq (MHz)	Modulation	RB	Result	Verdict
77	15	10	647000	3705.0	DFT-s-OFDM BPSK	1@0	see graph	---
77	15	10	647000	3705.0	DFT-s-OFDM BPSK	1@0	see graph	PASS
77	15	10	647000	3705.0	DFT-s-OFDM BPSK	1@0	see graph	PASS
77	15	10	647000	3705.0	DFT-s-OFDM QPSK	1@0	see graph	---
77	15	10	647000	3705.0	DFT-s-OFDM QPSK	1@0	see graph	PASS
77	15	10	647000	3705.0	DFT-s-OFDM QPSK	1@0	see graph	PASS
77	15	10	656000	3840.0	DFT-s-OFDM BPSK	1@0	see graph	---
77	15	10	656000	3840.0	DFT-s-OFDM BPSK	1@0	see graph	PASS
77	15	10	656000	3840.0	DFT-s-OFDM BPSK	1@0	see graph	PASS
77	15	10	656000	3840.0	DFT-s-OFDM QPSK	1@0	see graph	---
77	15	10	656000	3840.0	DFT-s-OFDM QPSK	1@0	see graph	PASS
77	15	10	656000	3840.0	DFT-s-OFDM QPSK	1@0	see graph	PASS
77	15	10	665000	3975.0	DFT-s-OFDM BPSK	1@0	see graph	---
77	15	10	665000	3975.0	DFT-s-OFDM BPSK	1@0	see graph	PASS
77	15	10	665000	3975.0	DFT-s-OFDM BPSK	1@0	see graph	PASS
77	15	10	665000	3975.0	DFT-s-OFDM QPSK	1@0	see graph	---
77	15	10	665000	3975.0	DFT-s-OFDM QPSK	1@0	see graph	PASS
77	15	10	665000	3975.0	DFT-s-OFDM QPSK	1@0	see graph	PASS
77	15	25	647500	3712.5	DFT-s-OFDM BPSK	1@0	see graph	---
77	15	25	647500	3712.5	DFT-s-OFDM BPSK	1@0	see graph	PASS
77	15	25	647500	3712.5	DFT-s-OFDM BPSK	1@0	see graph	PASS
77	15	25	647500	3712.5	DFT-s-OFDM QPSK	1@0	see graph	---
77	15	25	647500	3712.5	DFT-s-OFDM QPSK	1@0	see graph	PASS
77	15	25	647500	3712.5	DFT-s-OFDM QPSK	1@0	see graph	PASS
77	15	25	656000	3840.0	DFT-s-OFDM BPSK	1@0	see graph	---
77	15	25	656000	3840.0	DFT-s-OFDM BPSK	1@0	see graph	PASS
77	15	25	656000	3840.0	DFT-s-OFDM BPSK	1@0	see graph	PASS
77	15	25	656000	3840.0	DFT-s-OFDM QPSK	1@0	see graph	---
77	15	25	656000	3840.0	DFT-s-OFDM QPSK	1@0	see graph	PASS
77	15	25	656000	3840.0	DFT-s-OFDM QPSK	1@0	see graph	PASS
77	15	25	664500	3967.5	DFT-s-OFDM BPSK	1@0	see graph	---
77	15	25	664500	3967.5	DFT-s-OFDM BPSK	1@0	see graph	PASS
77	15	25	664500	3967.5	DFT-s-OFDM BPSK	1@0	see graph	PASS

77	15	25	664500	3967.5	DFT-s-OFDM QPSK	1@0	see graph	---
77	15	25	664500	3967.5	DFT-s-OFDM QPSK	1@0	see graph	PASS
77	15	25	664500	3967.5	DFT-s-OFDM QPSK	1@0	see graph	PASS
77	15	50	648334	3725.01	DFT-s-OFDM BPSK	1@0	see graph	---
77	15	50	648334	3725.01	DFT-s-OFDM BPSK	1@0	see graph	PASS
77	15	50	648334	3725.01	DFT-s-OFDM BPSK	1@0	see graph	PASS
77	15	50	648334	3725.01	DFT-s-OFDM QPSK	1@0	see graph	---
77	15	50	648334	3725.01	DFT-s-OFDM QPSK	1@0	see graph	PASS
77	15	50	648334	3725.01	DFT-s-OFDM QPSK	1@0	see graph	PASS
77	15	50	656000	3840.0	DFT-s-OFDM BPSK	1@0	see graph	---
77	15	50	656000	3840.0	DFT-s-OFDM BPSK	1@0	see graph	PASS
77	15	50	656000	3840.0	DFT-s-OFDM BPSK	1@0	see graph	PASS
77	15	50	656000	3840.0	DFT-s-OFDM QPSK	1@0	see graph	---
77	15	50	656000	3840.0	DFT-s-OFDM QPSK	1@0	see graph	PASS
77	15	50	656000	3840.0	DFT-s-OFDM QPSK	1@0	see graph	PASS
77	15	50	663666	3954.99	DFT-s-OFDM BPSK	1@0	see graph	---
77	15	50	663666	3954.99	DFT-s-OFDM BPSK	1@0	see graph	PASS
77	15	50	663666	3954.99	DFT-s-OFDM BPSK	1@0	see graph	PASS
77	15	50	663666	3954.99	DFT-s-OFDM QPSK	1@0	see graph	---
77	15	50	663666	3954.99	DFT-s-OFDM QPSK	1@0	see graph	PASS
77	15	50	663666	3954.99	DFT-s-OFDM QPSK	1@0	see graph	PASS

N77(10M)_DFT-s-OFDM_BPSK_Edge_1RB_Left_Low_CH



N77(10M)_DFT-s-OFDM_BPSK_Edge_1RB_Left_Low_CH

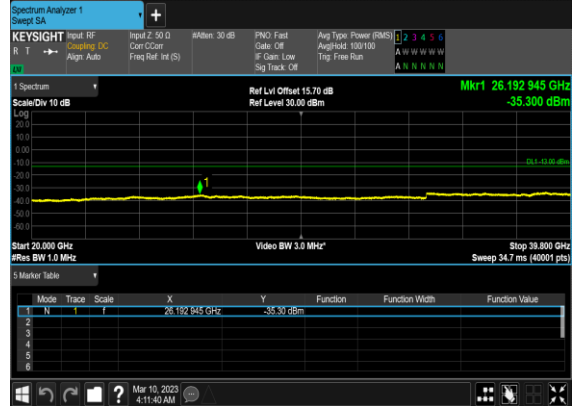

N77(10M)_DFT-s-OFDM_QPSK_Edge_1RB_Left_Low_CH



N77(10M)_DFT-s-OFDM_QPSK_Edge_1RB_Left_Low_CH

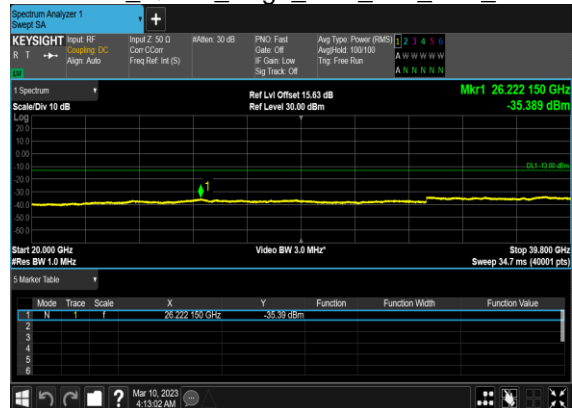

N77(10M)_DFT-s-OFDM_BPSK_Edge_1RB_Left_Mid_CH



N77(10M)_DFT-s-OFDM_BPSK_Edge_1RB_Left_Mid_CH



N77(10M)_DFT-s-OFDM_QPSK_Edge_1RB_Left_Mid_CH

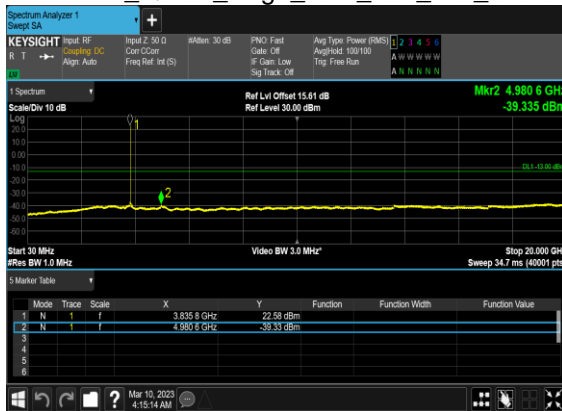

N77(10M)_DFT-s-OFDM_QPSK_Edge_1RB_Left_Mid_CH

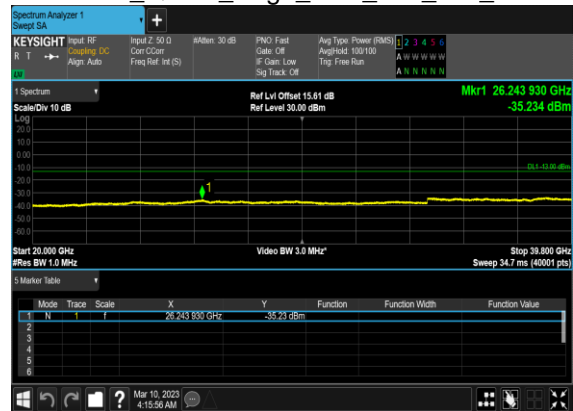

N77(10M)_DFT-s-OFDM_BPSK_Edge_1RB_Left_High_CH



N77(10M)_DFT-s-OFDM_BPSK_Edge_1RB_Left_High_CH

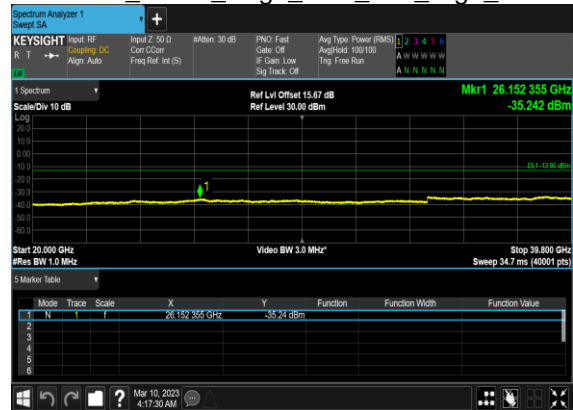

N77(10M)_DFT-s-OFDM_QPSK_Edge_1RB_Left_High_CH

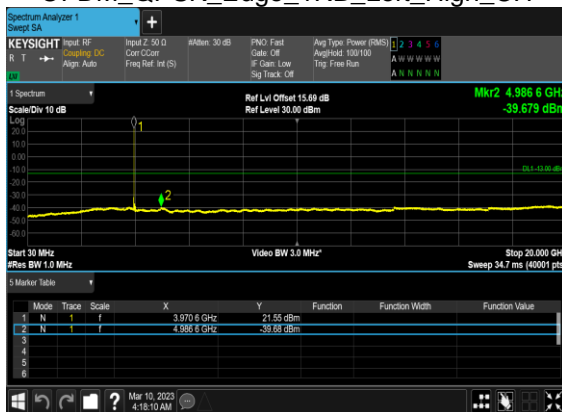

N77(10M)_DFT-s-OFDM_QPSK_Edge_1RB_Left_High_CH

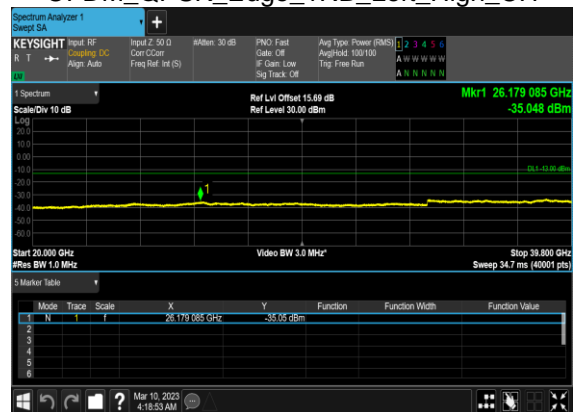

N77(25M)_DFT-s-OFDM_BPSK_Edge_1RB_Left_Low_CH



N77(25M)_DFT-s-OFDM_BPSK_Edge_1RB_Left_Low_CH

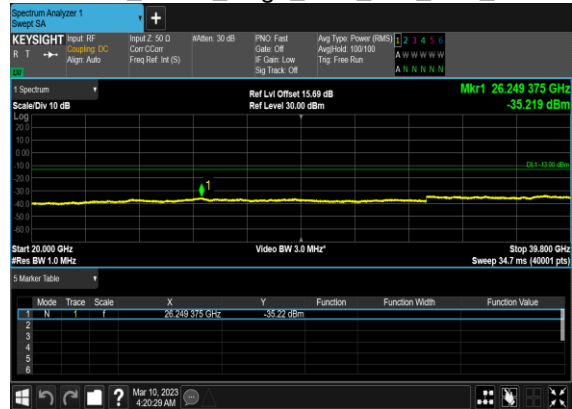

N77(25M)_DFT-s-OFDM_QPSK_Edge_1RB_Left_Low_CH



N77(25M)_DFT-s-OFDM_QPSK_Edge_1RB_Left_Low_CH



N77(25M)_DFT-s-OFDM_BPSK_Edge_1RB_Left_Mid_CH



N77(25M)_DFT-s-OFDM_BPSK_Edge_1RB_Left_Mid_CH

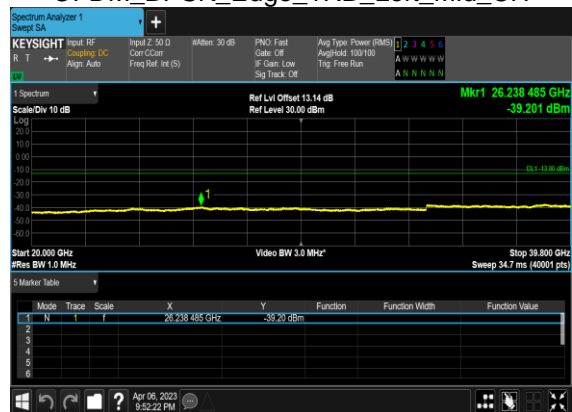

N77(25M)_DFT-s-OFDM_QPSK_Edge_1RB_Left_Mid_CH



N77(25M)_DFT-s-OFDM_QPSK_Edge_1RB_Left_Mid_CH

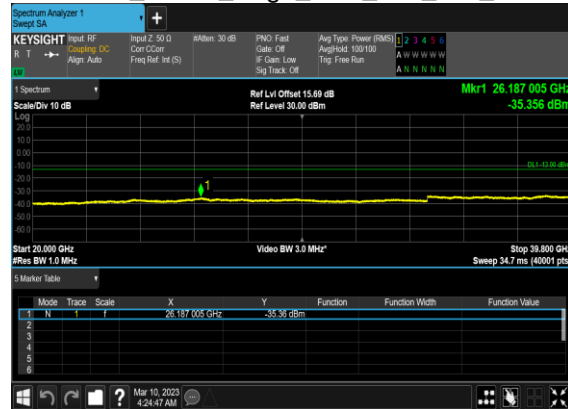

N77(25M)_DFT-s-OFDM_BPSK_Edge_1RB_Left_High_CH



N77(25M)_DFT-s-OFDM_BPSK_Edge_1RB_Left_High_CH

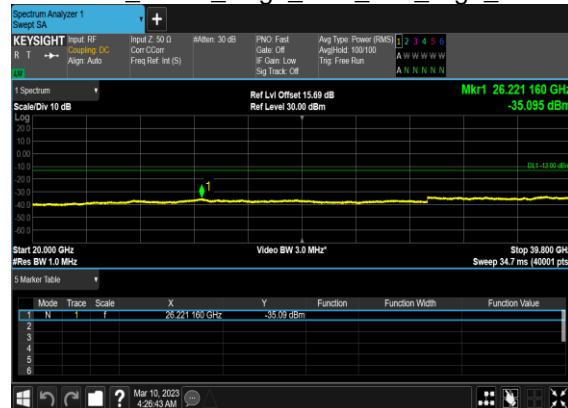

N77(25M)_DFT-s-OFDM_QPSK_Edge_1RB_Left_High_CH



N77(25M)_DFT-s-OFDM_QPSK_Edge_1RB_Left_High_CH

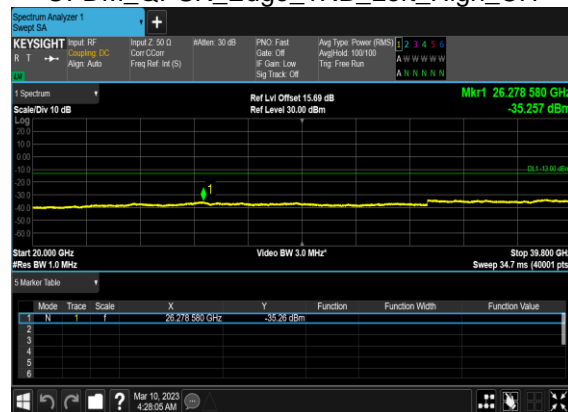

N77(50M)_DFT-s-OFDM_BPSK_Edge_1RB_Left_Low_CH



N77(50M)_DFT-s-OFDM_BPSK_Edge_1RB_Left_Low_CH

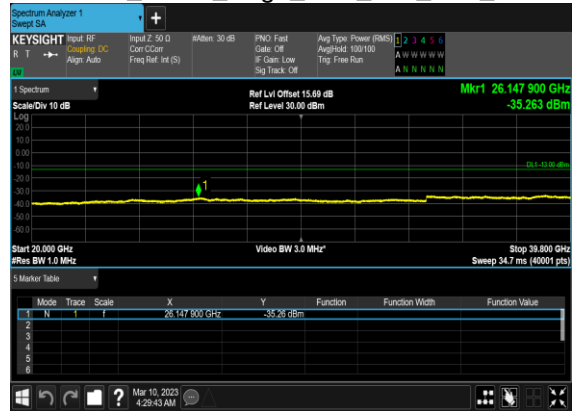

N77(50M)_DFT-s-OFDM_QPSK_Edge_1RB_Left_Low_CH



N77(50M)_DFT-s-OFDM_QPSK_Edge_1RB_Left_Low_CH

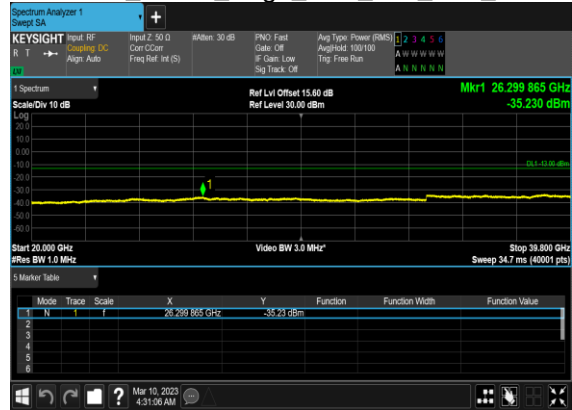

N77(50M)_DFT-s-OFDM_BPSK_Edge_1RB_Left_Mid_CH



N77(50M)_DFT-s-OFDM_BPSK_Edge_1RB_Left_Mid_CH



N77(50M)_DFT-s-OFDM_QPSK_Edge_1RB_Left_Mid_CH

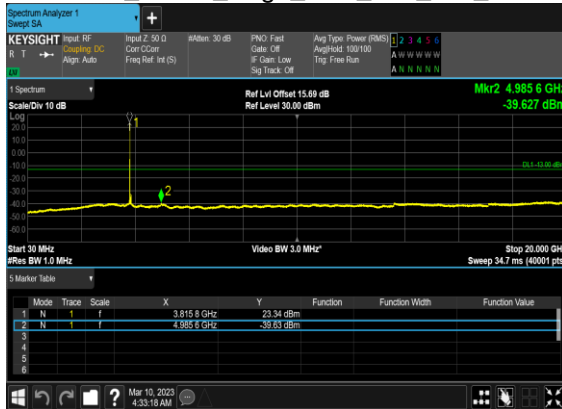

N77(50M)_DFT-s-OFDM_QPSK_Edge_1RB_Left_Mid_CH

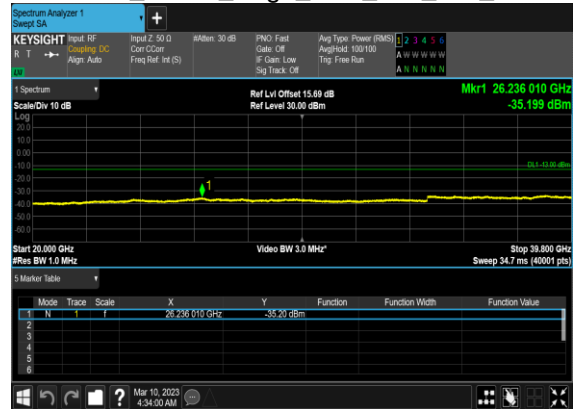

N77(50M)_DFT-s-OFDM_BPSK_Edge_1RB_Left_High_CH



N77(50M)_DFT-s-OFDM_BPSK_Edge_1RB_Left_High_CH



N77(50M)_DFT-s-OFDM_QPSK_Edge_1RB_Left_High_CH



N77(50M)_DFT-s-OFDM_QPSK_Edge_1RB_Left_High_CH

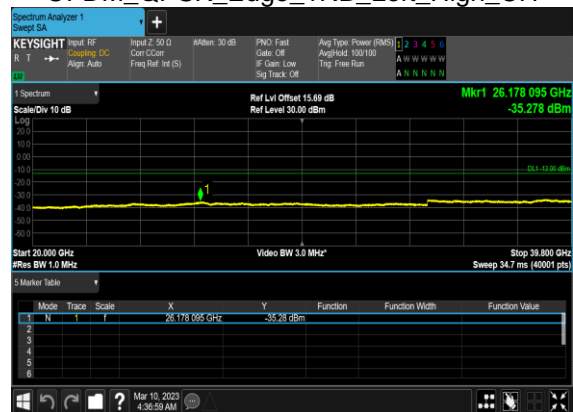

Conducted Band Edge

NR Band	SCS (kHz)	Bandwidth (MHz)	Arfcn	Freq (MHz)	Modulation	RB	Result	Verdict
77	15	10	647000	3705.0	DFT-s-OFDM BPSK	1@0	see graph	PASS
77	15	10	647000	3705.0	DFT-s-OFDM QPSK	1@0	see graph	PASS
77	15	10	647000	3705.0	DFT-s-OFDM BPSK	50@0	see graph	PASS
77	15	10	647000	3705.0	DFT-s-OFDM QPSK	50@0	see graph	PASS
77	15	10	665000	3975.0	DFT-s-OFDM BPSK	1@51	see graph	PASS
77	15	10	665000	3975.0	DFT-s-OFDM QPSK	1@51	see graph	PASS
77	15	10	665000	3975.0	DFT-s-OFDM BPSK	50@0	see graph	PASS
77	15	10	665000	3975.0	DFT-s-OFDM QPSK	50@0	see graph	PASS
77	15	25	647500	3712.5	DFT-s-OFDM BPSK	1@0	see graph	PASS
77	15	25	647500	3712.5	DFT-s-OFDM QPSK	1@0	see graph	PASS
77	15	25	647500	3712.5	DFT-s-OFDM BPSK	128@0	see graph	PASS
77	15	25	647500	3712.5	DFT-s-OFDM QPSK	128@0	see graph	PASS
77	15	25	664500	3967.5	DFT-s-OFDM BPSK	1@132	see graph	PASS
77	15	25	664500	3967.5	DFT-s-OFDM QPSK	1@132	see graph	PASS
77	15	25	664500	3967.5	DFT-s-OFDM BPSK	128@0	see graph	PASS
77	15	25	664500	3967.5	DFT-s-OFDM QPSK	128@0	see graph	PASS
77	15	50	648334	3725.01	DFT-s-OFDM BPSK	1@0	see graph	PASS
77	15	50	648334	3725.01	DFT-s-OFDM QPSK	1@0	see graph	PASS
77	15	50	648334	3725.01	DFT-s-OFDM BPSK	270@0	see graph	PASS
77	15	50	648334	3725.01	DFT-s-OFDM QPSK	270@0	see graph	PASS
77	15	50	663666	3954.99	DFT-s-OFDM BPSK	1@269	see graph	PASS
77	15	50	663666	3954.99	DFT-s-OFDM QPSK	1@269	see graph	PASS
77	15	50	663666	3954.99	DFT-s-OFDM BPSK	270@0	see graph	PASS
77	15	50	663666	3954.99	DFT-s-OFDM QPSK	270@0	see graph	PASS