



FCC RF Test Report

APPLICANT : Motorola Mobility LLC
EQUIPMENT : Mobile Cellular Phone
BRAND NAME : Motorola
MODEL NAME : XT2323-4, XT2323-7
FCC ID : IHDT56AL3
STANDARD : 47 CFR Part 2, 27
CLASSIFICATION : PCS Licensed Transmitter Held to Ear (PCE)
TEST DATE(S) : Jun. 01, 2023 ~ Jun. 08, 2023

We, Sporton International Inc. (Kunshan), would like to declare that the tested sample has been evaluated in accordance with the procedures given in ANSI C63.26-2015 and shown compliance with the applicable technical standards.

The test results in this report apply exclusively to the tested model / sample. Without written approval of Sporton International Inc. (Kunshan), the test report shall not be reproduced except in full.

Jason Jia



Approved by: Jason Jia

Sporton International Inc. (Kunshan)

**No. 1098, Pengxi North Road, Kunshan Economic Development Zone Jiangsu Province 215300
People's Republic of China**



TABLE OF CONTENTS

REVISION HISTORY 3
SUMMARY OF TEST RESULT 4
1 GENERAL DESCRIPTION 5
1.1 Applicant 5
1.2 Manufacturer 5
1.3 Product Feature of Equipment Under Test 5
1.4 Product Specification of Equipment Under Test 5
1.5 Modification of EUT 6
1.6 Specification of Accessory 6
1.7 Maximum EIRP Power and Emission Designator 6
1.8 Testing Location 7
1.9 Test Software 7
1.10 Applicable Standards 8
2 TEST CONFIGURATION OF EQUIPMENT UNDER TEST 9
2.1 Test Mode 9
2.2 Connection Diagram of Test System 10
2.3 Support Unit used in test configuration and system 10
2.4 Measurement Results Explanation Example 11
2.5 Frequency List of Low/Middle/High Channels 11
3 CONDUCTED TEST ITEMS 12
3.1 Measuring Instruments 12
3.2 Test Setup 12
3.3 Test Result of Conducted Test 12
3.4 Conducted Output Power and EIRP 13
3.5 Peak-to-Average Ratio 14
3.6 Occupied Bandwidth 15
3.7 Conducted Band Edge 16
3.8 Conducted Spurious Emission 17
3.9 Frequency Stability 18
4 RADIATED TEST ITEMS 19
4.1 Measuring Instruments 19
4.2 Test Setup 19
4.3 Test Result of Radiated Test 20
4.4 Radiated Spurious Emission 21
5 LIST OF MEASURING EQUIPMENT 22
6 MEASUREMENT UNCERTAINTY 23
APPENDIX A. TEST RESULTS OF CONDUCTED TEST
APPENDIX B. TEST RESULTS OF RADIATED TEST
APPENDIX C. TEST SETUP PHOTOGRAPHS



REVISION HISTORY

REPORT NO.	VERSION	DESCRIPTION	ISSUED DATE
FG340401-04B	Rev. 01	Initial issue of report	Jun. 28, 2023



SUMMARY OF TEST RESULT

Report Section	FCC Rule	Description	Limit	Result	Remark
3.4	§2.1046	Conducted Output Power	Reporting Only	PASS	-
	§27.50(h)(2)	Equivalent Isotropic Radiated Power (5G NR n41)	EIRP < 2Watt		
3.6	§2.1049	Occupied Bandwidth	Reporting Only	PASS	-
3.7	§27.53(m)(4)	Conducted Band Edge Measurement (5G NR n41)	§27.53(m)(4)	PASS	-
3.8	§2.1051 §27.53(m)(4)	Conducted Spurious Emission (5G NR n41)	< 55+10log ₁₀ (P[Watts])	PASS	-
3.9	§27.54	Frequency Stability Temperature & Voltage	Within Authorized Band	PASS	-
4.4	§2.1053 §27.53(m)(4)	Radiated Spurious Emission (5G NR n41)	< 55+10log ₁₀ (P[Watts])	PASS	Under limit 21.07 dB at 7492.000 MHz

Conformity Assessment Condition:

1. The test results (PASS/FAIL) with all measurement uncertainty excluded are presented against the regulation limits or in accordance with the requirements stipulated by the applicant/manufacturer who shall bear all the risks of non-compliance that may potentially occur if measurement uncertainty is taken into account.
2. The measurement uncertainty please refer to each test result in the section "Measurement Uncertainty"

Disclaimer:

The product specifications of the EUT presented in the test report that may affect the test assessments are declared by the manufacturer who shall take full responsibility for the authenticity.



1 General Description

1.1 Applicant

Motorola Mobility LLC
222 W,Merchandise Mart Plaza, Chicago IL 60654 USA

1.2 Manufacturer

Motorola Mobility LLC
222 W,Merchandise Mart Plaza, Chicago IL 60654 USA

1.3 Product Feature of Equipment Under Test

Product Feature	
Equipment	Mobile Cellular Phone
Brand Name	Motorola
Model Name	XT2323-4, XT2323-7
FCC ID	IHDT56AL3
IMEI Code	Conducted: 354478360011399/354478360011407 Radiation: 350492020024498/350492020024506
HW Version	DVT2
SW Version	T2TV33.27
EUT Stage	Identical Prototype

Remark: The two models XT2323-4, XT2323-7 are only for market differentiation, all the others are the same.

1.4 Product Specification of Equipment Under Test

Standards-related Product Specification	
Tx Frequency	5G NR n41 : 2496 MHz ~ 2690 MHz
Rx Frequency	5G NR n41 : 2496 MHz ~ 2690 MHz
Bandwidth	n41 : 20MHz / 30MHz / 40MHz / 50MHz / 60MHz / 70MHz / 80MHz / 90MHz / 100MHz
SCS	n41: 30kHz
Antenna Gain	<Ant. 0>n41: -0.32 dBi <Ant. 1>n41: -3.80 dBi <Ant. 2>n41: -4.70 dBi <Ant. 3>n41: -1.00 dBii
Type of Modulation	CP-OFDM: QPSK / 16QAM / 64QAM / 256QAM DFT-s-OFDM: PI/2 BPSK / QPSK / 16QAM / 64QAM / 256QAM

Remark:

1. The maximum EIRP is calculated from max output power and max antenna gain, only the maximum EIRP are shown in the report, 5G NR n41 for Ant. 3 and n41_UL MIMO for Ant.(3+1).
2. 5G NR n41 support SA mode and NSA mode. According to the maximum power between SA and NSA mode, SA covers NSA mode.



3. The device supports two PAs for 5G NR n41(main PA and other PA for ENDC_2A_n41A), the maximum power of other PA is higher than the main PA, but the antenna gain of main PA is higher, therefore, we chose main PA to calculate the EIRP and show in the report.
4. 5G NR n41 SA/NSA mode and UL MIMO mode support Power class 3.
5. 5G NR n41 support UL MIMO mode for Ant(3+1) / Ant(2+0), only the worst test data of Ant(3+1) for n41 is shown in the report by referring to the higher conducted power.
6. 5G NR n41 supports UL MIMO mode is completely uncorrelated, so the directional gain is selected the maximum gain among all antennas.
7. 5G NR n41 only supports CP-OFDM modulation in UL MIMO mode.
8. For n41 UL MIMO mode, the conducted BE/Spurious are tested at single antenna port and add $10 \cdot \log(N_{ANT})$ according to KDB 662911 D01.
9. All the supported EN-DC combinations are verified conducted power, only the EN-DC combination with highest power are shown in the report.
10. The EN-DC mode combination could be referred to the product spec.

1.5 Modification of EUT

No modifications are made to the EUT during all test items.

1.6 Specification of Accessory

Specification of Accessory				
Base Battery	Brand Name	Motorola(ATL)	Model Name	PM29
Flip Battery	Brand Name	Motorola(ATL)	Model Name	PV11

1.7 Maximum EIRP Power and Emission Designator

5G NR n41		PI/2 BPSK / QPSK		16QAM / 64QAM / 256QAM	
BW (MHz)	Frequency Range (MHz)	Maximum EIRP(W)	Emission Designator (99%OBW)	Maximum EIRP(W)	Emission Designator (99%OBW)
20	2506.02 ~ 2679.99	0.1542	18M3G7D	0.1489	18M2W7D
30	2511.00 ~ 2674.98	0.1545	27M9G7D	0.1514	27M9W7D
40	2516.01 ~ 2670.00	0.1574	37M8G7D	0.1517	38M0W7D
50	2521.02 ~ 2664.99	0.1531	47M5G7D	0.1507	47M6W7D
60	2526.00 ~ 2659.98	0.1545	57M9G7D	0.1517	57M9W7D
70	2531.01 ~ 2655.00	0.1489	67M4G7D	0.1483	67M6W7D
80	2536.02 ~ 2649.99	0.1479	77M7G7D	0.1542	77M6W7D
90	2541.00 ~ 2644.98	0.1500	87M4G7D	0.1442	87M6W7D
100	2546.01 ~ 2640.00	0.1581	97M5G7D	0.1462	97M6W7D



5G NR n41 UL MIMO		QPSK		16QAM / 64QAM / 256QAM	
BW (MHz)	Frequency Range (MHz)	Maximum EIRP(W)	Emission Designator (99%OBW)	Maximum EIRP(W)	Emission Designator (99%OBW)
20	2506.02 ~ 2679.99	0.1574	18M2G7D	0.1406	18M2W7D
30	2511.00 ~ 2674.98	0.1611	27M8G7D	0.1422	27M9W7D
40	2516.01 ~ 2670.00	0.1574	37M8G7D	0.1476	37M9W7D
50	2521.02 ~ 2664.99	0.1578	47M6G7D	0.1409	47M5W7D
60	2526.00 ~ 2659.98	0.1589	57M8G7D	0.1396	58M2W7D
70	2531.01 ~ 2655.00	0.1531	67M6G7D	0.1352	67M6W7D
80	2536.02 ~ 2649.99	0.1521	77M6G7D	0.1349	77M8W7D
90	2541.00 ~ 2644.98	0.1521	87M6G7D	0.1365	87M8W7D
100	2546.01 ~ 2640.00	0.1644	97M6G7D	0.1384	97M7W7D

Note: All modulations have been tested, only the worst test results of PSK & QAM are shown in the report.

1.8 Testing Location

Sporton International Inc. (Kunshan) is accredited to ISO/IEC 17025:2017 by American Association for Laboratory Accreditation with Certificate Number 5145.02.

Test Firm	Sporton International Inc. (Kunshan)		
Test Site Location	No. 1098, Pengxi North Road, Kunshan Economic Development Zone Jiangsu Province 215300 People's Republic of China TEL : +86-512-57900158		
Test Site No.	Sporton Site No.	FCC Designation No.	FCC Test Firm Registration No.
	03CH04-KS TH01-KS	CN1257	314309

1.9 Test Software

Item	Site	Manufacturer	Name	Version
1.	03CH04-KS	AUDIX	E3	6.2009-8-24al



1.10 Applicable Standards

According to the specifications of the manufacturer, the EUT must comply with the requirements of the following standards:

- ♦ 47 CFR Part 2, 27
- ♦ ANSI C63.26-2015
- ♦ FCC KDB 971168 D01 Power Meas License Digital Systems v03r01
- ♦ FCC KDB 412172 D01 Determining ERP and EIRP v01r01

Remark:

All test items were verified and recorded according to the standards and without any deviation during the test.



2 Test Configuration of Equipment Under Test

2.1 Test Mode

Antenna port conducted and radiated test items are performed according to KDB 971168 D01 Power Meas License Digital Systems v03r01 with maximum output power.

For radiated measurement, pre-scanned flip open and close state in three orthogonal panels X, Y, Z. The worst cases (Z plane with flip open) were recorded in this report

The device is investigated from 30MHz to 10 times of fundamental signal for radiated spurious emission test under different RB size/offset and modulations in exploratory test. Subsequently, only the worst case emissions are reported.

Orthogonal Planes of EUT	X Plane	Y Plane	Z Plane
			

Test Items	5G NR	Bandwidth (MHz)														Modulation			RB #		Test Channel				
		5	10	15	20	25	30	40	50	60	70	80	90	100	PI/2 BPSK	QPSK	16 QAM	64 QAM	256 QAM	1	Full	L	M	H	
Max. Output Power	n41	-	-	-	v	-	v	v	v	v	v	v	v	v	v	v	v	v	v	v	v	v	v	v	v
Peak-to-Average Ratio	n41	-	-	-	-	-	-	-	-	-	-	-	-	v	v	v	-	-	-	v	v	-	-	v	v
26dB and 99% Bandwidth	n41	-	-	-	v	-	v	v	v	v	v	v	v	-	v	v	v	v	-	-	v	-	-	v	-
Conducted Band Edge	n41	-	-	-	v	-	-	-	-	v	-	-	-	v	v	v	-	-	-	v	v	v	-	-	v
Conducted Spurious Emission	n41	-	-	-	v	-	-	-	-	v	-	-	-	v	v	v	-	-	-	v	-	-	v	v	v
Frequency Stability	n41	-	-	-	v	-	-	-	-	-	-	-	-	-	v	-	-	-	-	v	-	-	-	v	-
E.I.R.P	n41	-	-	-	v	-	v	v	v	v	v	v	v	v	v	v	v	v	v	v	v	v	v	v	v
Radiated Spurious Emission	n41	Worst Case																			v	v	v		
Note	<p>The mark "v" means that this configuration is chosen for testing</p> <p>The mark "-" means that this bandwidth is not supported.</p> <p>The device is investigated from 30MHz to 10 times of fundamental signal for radiated spurious emission test under different RB size/offset and modulations in exploratory test. Subsequently, only the worst case emissions are reported.</p> <p>Frequency Stability : Normal Voltage = 3.91V ; Low Voltage =3.4V. ; High Voltage =4.5V</p> <p>All test items are based on engineering evaluation.</p>																								

2.2 Connection Diagram of Test System

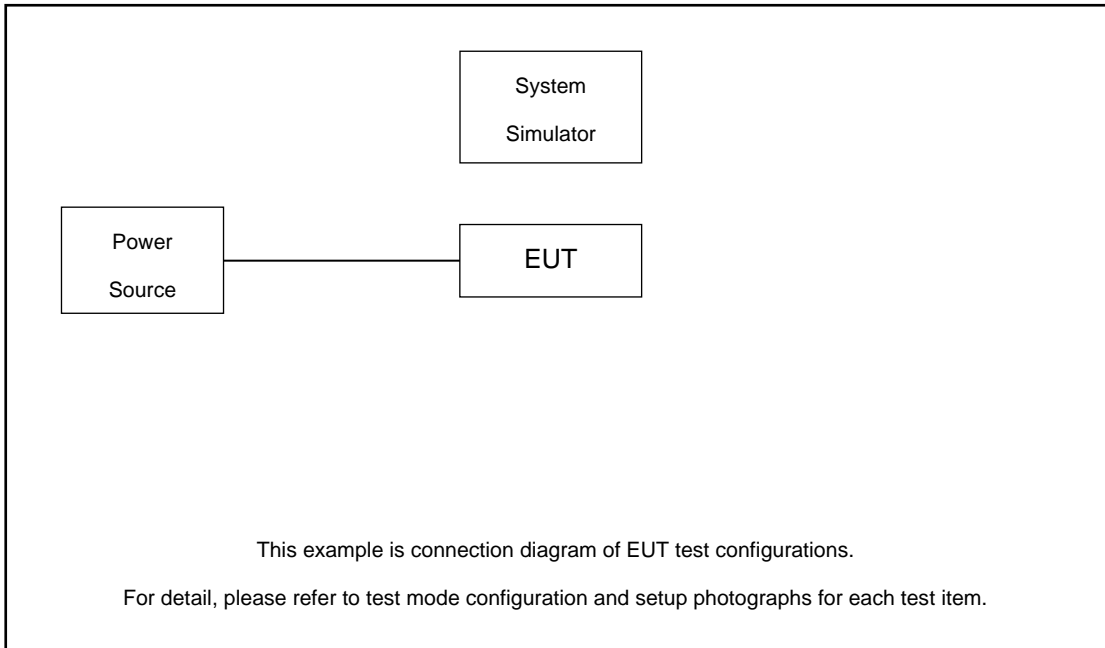

The EUT has been configuration operated in a manner tended to maximize its emission characteristics in a typical application.

2.3 Support Unit used in test configuration and system

Item	Equipment	Trade Name	Model No.	FCC ID	Data Cable	Power Cord
1.	DC Power Supply	GW	GPS-3030D	N/A	N/A	Unshielded, 1.8 m
2.	LTE Base Station	Anritsu	MT8820/8821	N/A	N/A	Unshielded, 1.8 m
3.	NR Base Station	Anritsu	MT8000A	N/A	N/A	Unshielded, 1.8 m
4.	Adapter	N/A	N/A	N/A	N/A	N/A
5.	USB cable	N/A	N/A	N/A	N/A	N/A



2.4 Measurement Results Explanation Example

For all conducted test items:

The offset level is set in the spectrum analyzer to compensate the RF cable loss and attenuator factor between EUT conducted output port and spectrum analyzer. With the offset compensation, the spectrum analyzer reading level is exactly the EUT RF output level.

The spectrum analyzer offset is derived from RF cable loss and attenuator factor.

$$\text{Offset} = \text{RF cable loss} + \text{attenuator factor}.$$

Following shows an offset computation example with cable loss 6.0 dB and 20dB attenuator.

Example :

$$\begin{aligned} \text{Offset(dB)} &= \text{RF cable loss(dB)} + \text{attenuator factor(dB)}. \\ &= 6.0 + 20 = 26.0 \text{ (dB)} \end{aligned}$$

2.5 Frequency List of Low/Middle/High Channels

5G NR n41 Channel and Frequency List				
BW [MHz]	Channel/Frequency(MHz)	Lowest	Middle	Highest
100	Channel	509202	518598	528000
	Frequency	2546.01	2592.99	2640
90	Channel	508200	518598	528996
	Frequency	2541	2592.99	2644.98
80	Channel	507204	518598	529998
	Frequency	2536.02	2592.99	2649.99
70	Channel	506202	518598	531000
	Frequency	2531.01	2592.99	2655
60	Channel	505200	518598	531996
	Frequency	2526	2592.99	2659.98
50	Channel	504204	518598	532998
	Frequency	2521.02	2592.99	2664.99
40	Channel	503202	518598	534000
	Frequency	2516.01	2592.99	2670
30	Channel	502200	518598	534996
	Frequency	2511	2592.99	2674.98
20	Channel	501204	518598	535998
	Frequency	2506.02	2592.99	2679.99

3 Conducted Test Items

3.1 Measuring Instruments

See list of measuring instruments of this test report.

3.2 Test Setup

3.2.1 Conducted Output Power

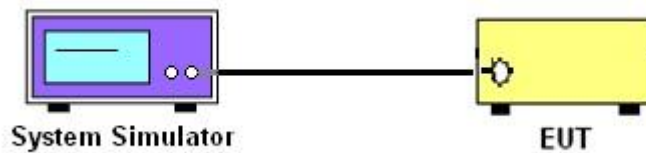

3.2.2 Peak-to-Average Ratio, Occupied Bandwidth, Conducted Band-Edge and Conducted Spurious Emission

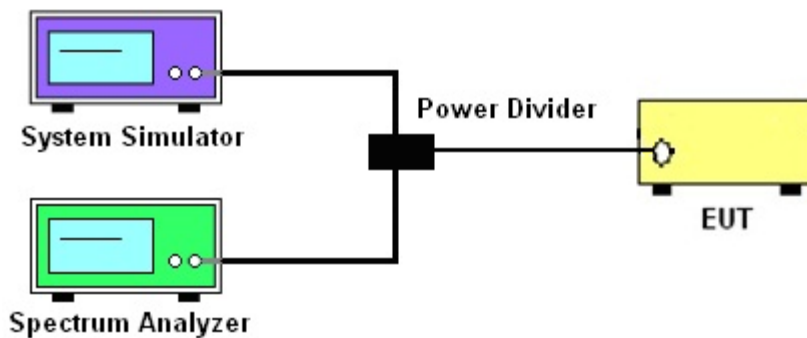

3.2.3 Frequency Stability

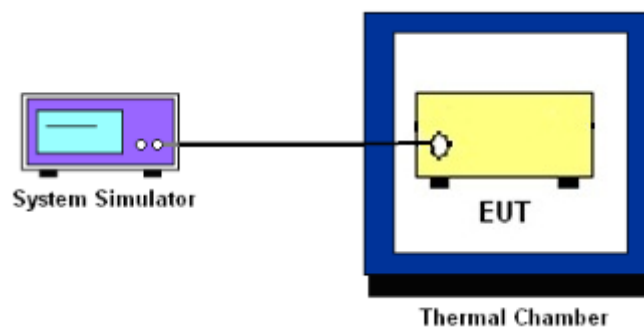

3.3 Test Result of Conducted Test

Please refer to Appendix A.



3.4 Conducted Output Power and EIRP

3.4.1 Description of the Conducted Output Power Measurement and EIRP Measurement

A system simulator was used to establish communication with the EUT. Its parameters were set to force the EUT transmitting at maximum output power. The measured power in the radio frequency on the transmitter output terminals shall be reported.

The EIRP of mobile transmitters must not exceed 2 Watts for 5G NR n41.

According to KDB 412172 D01 Power Approach,

$EIRP = P_T + G_T - L_C$, $ERP = EIRP - 2.15$, where

P_T = transmitter output power in dBm

G_T = gain of the transmitting antenna in dBi

L_C = signal attenuation in the connecting cable between the transmitter and antenna in dB

3.4.2 Test Procedures

1. The testing follows ANSI C63.26 Section 5.2
2. The transmitter output port was connected to the system simulator.
3. Set EUT at maximum power through the system simulator.
4. Select lowest, middle, and highest channels for each band and different modulation.
5. Measure and record the power level from the system simulator.



3.5 Peak-to-Average Ratio

3.5.1 Description of the PAR Measurement

Power Complementary Cumulative Distribution Function (CCDF) curves provide a means for characterizing the power peaks of a digitally modulated signal on a statistical basis. A CCDF curve depicts the probability of the peak signal amplitude exceeding the average power level. Most contemporary measurement instrumentation include the capability to produce CCDF curves for an input signal provided that the instrument's resolution bandwidth can be set wide enough to accommodate the entire input signal bandwidth. In measuring transmissions in this band using an average power technique, the peak-to-average ratio (PAR) of the transmission may not exceed 13 dB.

3.5.2 Test Procedures

1. The testing follows ANSI C63.26 Section 5.2.3.4 (CCDF).
2. The EUT was connected to spectrum and system simulator via a power divider.
3. Set the CCDF (Complementary Cumulative Distribution Function) option in spectrum analyzer.
4. The highest RF powers were measured and recorded the maximum PAPR level associated with a probability of 0.1 %.
5. Record the deviation as Peak to Average Ratio.



3.6 Occupied Bandwidth

3.6.1 Description of Occupied Bandwidth Measurement

The occupied bandwidth is the width of a frequency band such that, below the lower and above the upper frequency limits, the mean powers emitted are each equal to a specified percentage 0.5% of the total mean transmitted power.

The 26 dB emission bandwidth is defined as the frequency range between two points, one above and one below the carrier frequency, at which the spectral density of the emission is attenuated 26 dB below the maximum in-band spectral density of the modulated signal. Spectral density (power per unit bandwidth) is to be measured with a detector of resolution bandwidth equal to approximately 1.0% of the emission bandwidth.

3.6.2 Test Procedures

1. The testing follows ANSI C63.26 Section 5.4
2. The EUT was connected to spectrum analyzer and system simulator via a power divider.
3. The spectrum analyzer center frequency is set to the nominal EUT channel center frequency. The span range for the spectrum analyzer shall be between two and five times the anticipated OBW.
4. The nominal resolution bandwidth (RBW) shall be in the range of 1 to 5 % of the anticipated OBW, and the VBW shall be at least 3 times the RBW.
5. Set the detection mode to peak, and the trace mode to max hold.
6. Determine the reference value: Set the EUT to transmit a modulated signal. Allow the trace to stabilize. Set the spectrum analyzer marker to the highest level of the displayed trace. (this is the reference value)
7. Determine the “-26 dB down amplitude” as equal to (Reference Value – X).
8. Place two markers, one at the lowest and the other at the highest frequency of the envelope of the spectral display such that each marker is at or slightly below the “-X dB down amplitude” determined in step 6. If a marker is below this “-X dB down amplitude” value it shall be placed as close as possible to this value. The OBW is the positive frequency difference between the two markers.
9. Use the 99 % power bandwidth function of the spectrum analyzer and report the measured bandwidth.



3.7 Conducted Band Edge

3.7.1 Description of Conducted Band Edge Measurement

27.53(m)(4)

For mobile digital stations, the attenuation factor shall be not less than $40 + 10 \log (P)$ dB on all frequencies between the channel edge and 5 megahertz from the channel edge, $43 + 10 \log (P)$ dB on all frequencies between 5 megahertz and X megahertz from the channel edge, and $55 + 10 \log (P)$ dB on all frequencies more than X megahertz from the channel edge, where X is the greater of 6 megahertz or the actual emission bandwidth as defined in paragraph (m)(6) of this section. In addition, the attenuation factor shall not be less than $43 + 10 \log (P)$ dB on all frequencies between 2490.5 MHz and 2496 MHz and $55 + 10 \log (P)$ dB at or below 2490.5 MHz. Mobile Satellite Service licensees operating on frequencies below 2495 MHz may also submit a documented interference complaint against BRS licensees operating on channel BRS Channel 1 on the same terms and conditions as adjacent channel BRS or EBS licensees.

3.7.2 Test Procedures

1. The testing follows ANSI C63.26 section 5.7
2. The EUT was connected to spectrum analyzer and system simulator via a power divider.
3. The band edges of low and high channels for the highest RF powers were measured.
4. Set RBW \geq 1% EBW in the 1MHz band immediately outside and adjacent to the band edge.
5. Beyond the 1 MHz band from the band edge, RBW=1MHz was used or a narrower RBW was used (generally limited to no less than 1% of the OBW) and the measured power was integrated over the full required measurement bandwidth.
6. Set spectrum analyzer with RMS detector.
7. The RF fundamental frequency should be excluded against the limit line in the operating frequency band.
8. Checked that all the results comply with the emission limit line.

Example:

The limit line is derived from $43 + 10\log(P)$ dB below the transmitter power P(Watts)
 $= P(W) - [43 + 10\log(P)]$ (dB)
 $= [30 + 10\log(P)]$ (dBm) - $[43 + 10\log(P)]$ (dB) = -13dBm.

9. For 5G NR n41, the other 40 dB, and 55 dB have additionally applied same calculation above.
10. When using the integration method, the starting frequency of the integration shall be centered at one-half of the RBW away from the band edge.



3.8 Conducted Spurious Emission

3.8.1 Description of Conducted Spurious Emission Measurement

For 5G NR n41:

The power of any emission outside of the authorized operating frequency ranges must be lower than the transmitter power (P) by a factor of at least $55 + 10 \log (P)$ dB.

It is measured by means of a calibrated spectrum analyzer and scanned from 30 MHz up to a frequency including its 10th harmonic.

3.8.2 Test Procedures

1. The testing follows ANSI C63.26 section 5.7
2. The EUT was connected to spectrum analyzer and system simulator via a power divider.
3. The RF output of EUT was connected to the spectrum analyzer by RF cable and attenuator. The path loss was compensated to the results for each measurement.
4. The middle channel for the highest RF power within the transmitting frequency was measured.
5. The conducted spurious emission for the whole frequency range was taken.
6. Make the measurement with the spectrum analyzer's RBW = 1MHz, VBW = 3MHz.
7. Set spectrum analyzer with RMS detector.
8. Taking the record of maximum spurious emission.
9. The RF fundamental frequency should be excluded against the limit line in the operating frequency band.
10. For 5G NR n41

The limit line is derived from $55 + 10\log(P)$ dB below the transmitter power P(Watts)
= P(W)- [55+ 10log(P)] (dB)
= [30+ 10log(P)] (dBm) - [55+ 10log(P)] (dB)
= -25dBm.



3.9 Frequency Stability

3.9.1 Description of Frequency Stability Measurement

The frequency stability shall be measured by variation of ambient temperature and variation of primary supply voltage to ensure that the fundamental emission stays within the authorized frequency block. The frequency stability of the transmitter shall be maintained within $\pm 0.00025\%$ ($\pm 2.5\text{ppm}$) of the center frequency.

3.9.2 Test Procedures for Temperature Variation

1. The testing follows ANSI C63.26 section 5.6.4
2. The EUT was set up in the thermal chamber and connected with the system simulator.
3. With power OFF, the temperature was decreased to -30°C and the EUT was stabilized before testing. Power was applied and the maximum change in frequency was recorded within one minute.
4. With power OFF, the temperature was raised in 10°C step up to 50°C . The EUT was stabilized at each step for at least half an hour. Power was applied and the maximum frequency change was recorded within one minute.

3.9.3 Test Procedures for Voltage Variation

1. The testing follows ANSI C63.26 section 5.6.5
2. The EUT was placed in a temperature chamber at $20\pm 5^{\circ}\text{C}$ and connected with the system simulator.
3. The power supply voltage to the EUT was varied from 85% to 115% of the nominal value for other than hand carried battery equipment.
4. For hand carried, battery powered equipment, reduce the primary ac or dc supply voltage to the battery operating end point, which shall be specified by the manufacturer.
5. The variation in frequency was measured for the worst case.

4 Radiated Test Items

4.1 Measuring Instruments

See list of measuring instruments of this test report.

4.2 Test Setup

4.2.1 For radiated test below 30MHz

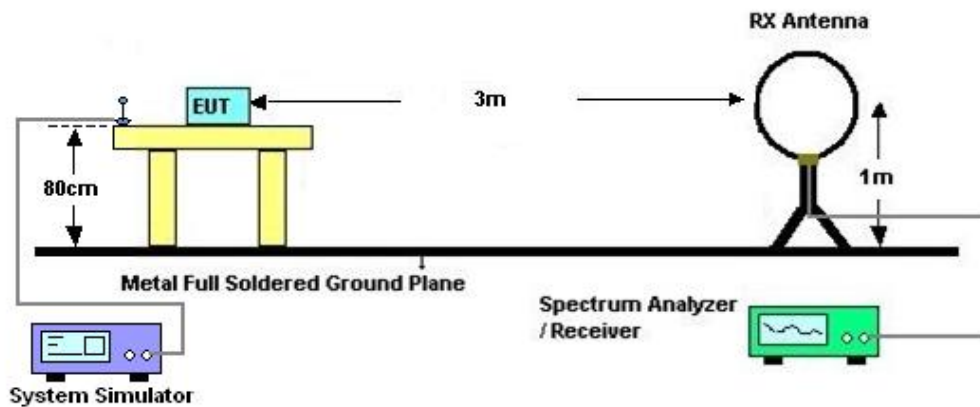

4.2.2 For radiated test from 30MHz to 1GHz

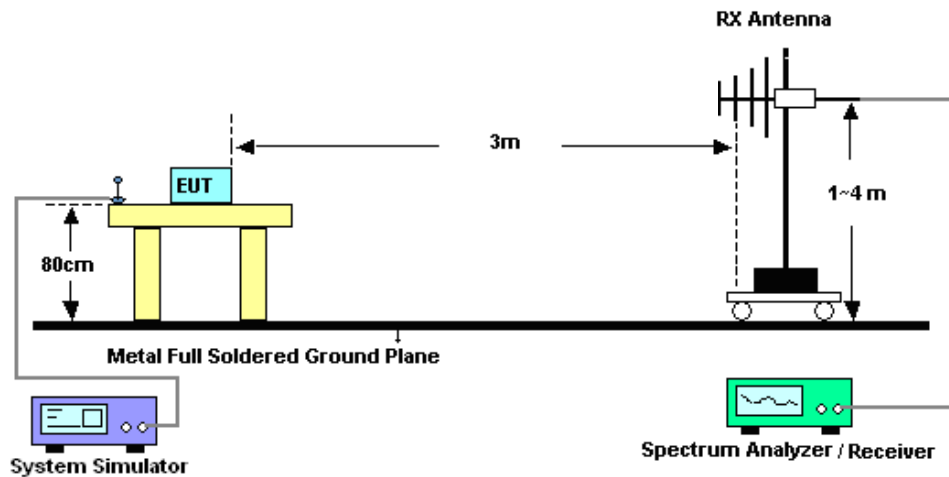

4.2.3 For radiated test above 1GHz

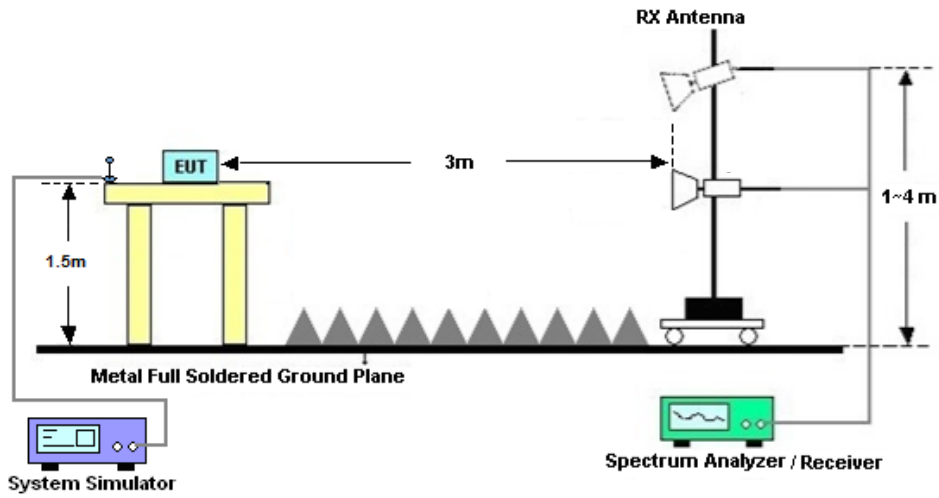

4.3 Test Result of Radiated Test

The low frequency, which started from 9 kHz to 30MHz, was pre-scanned and the result which was 20dB lower than the limit line was not reported.

Please refer to Appendix B.



4.4 Radiated Spurious Emission

4.4.1 Description of Radiated Spurious Emission

The radiated spurious emission was measured by substitution method according to ANSI C63.26.

The power of any emission outside of the authorized operating frequency ranges must be attenuated below the transmitter power (P) by a factor of at least $55 + 10 \log(P)$ dB.

The spectrum is scanned from 30 MHz up to a frequency including its 10th harmonic.

4.4.2 Test Procedures

1. The testing follows ANSI C63.26 Section 5.5
2. The EUT was placed on a turntable with 0.8 meter height for frequency below 1GHz and 1.5 meter height for frequency above 1GHz respectively above ground.
3. The EUT was set 3 meters from the receiving antenna mounted on the antenna tower.
4. The table was rotated 360 degrees to determine the position of the highest spurious emission.
5. The height of the receiving antenna is varied between 1m to 4m to search the maximum spurious emission for both horizontal and vertical polarizations.
6. During the measurement, the system simulator parameters were set to force the EUT transmitting at maximum output power.
7. Make the measurement with the spectrum analyzer's RBW = 1MHz, VBW = 3MHz, taking the record of maximum spurious emission.
8. A horn antenna was substituted in place of the EUT and was driven by a signal generator.
9. Tune the output power of signal generator to the same emission level with EUT maximum spurious emission.
10. $EIRP \text{ (dBm)} = S.G. \text{ Power} - Tx \text{ Cable Loss} + Tx \text{ Antenna Gain}$
11. $ERP \text{ (dBm)} = EIRP - 2.15$
12. The RF fundamental frequency should be excluded against the limit line in the operating frequency band.
13. For 5G NR n41:
The limit line is derived from $55 + 10\log(P)$ dB below the transmitter power P(Watts)The limit line is derived from $55 + 10\log(P)$ dB below the transmitter power P(Watts)



5 List of Measuring Equipment

Instrument	Manufacturer	Model No.	Serial No.	Characteristics	Calibration Date	Test Date	Due Date	Remark
Spectrum Analyzer	R&S	FSV40	101040	10Hz~40GHz	Oct. 12, 2022	Jun. 03, 2023~ Jun. 08, 2023	Oct. 11, 2023	Conducted (TH01-KS)
Power divider	STI	STI08-0055	-	0.5~40GHz	Aug. 26, 2022	Jun. 03, 2023~ Jun. 08, 2023	Aug. 25, 2023	Conducted (TH01-KS)
Temperature & humidity chamber	Hongzhan	LP-150U	H2014011440	-40~+150°C 20%~95%RH	Jul. 15, 2022	Jun. 03, 2023~ Jun. 08, 2023	Jul. 14, 2023	Conducted (TH01-KS)
EXA Spectrum Analyzer	Keysight	N9010B	MY57471079	10Hz-44G,MAX 30dB	Oct. 12, 2022	Jun. 01, 2023	Oct. 11, 2023	Radiation (03CH04-KS)
Loop Antenna	R&S	HFH2-Z2	100321	9kHz~30MHz	Oct. 16, 2022	Jun. 01, 2023	Oct. 15, 2023	Radiation (03CH04-KS)
Bilog Antenna	TeseQ	CBL6111D	49922	30MHz-1GHz	Apr. 09, 2023	Jun. 01, 2023	Apr. 08, 2024	Radiation (03CH04-KS)
Horn Antenna	Schwarzbeck	BBHA9120D	1284	1GHz~18GHz	Oct. 16, 2022	Jun. 01, 2023	Oct. 15, 2023	Radiation (03CH04-KS)
SHF-EHF Horn	Com-power	AH-840	101070	18GHz~40GHz	Jan. 08, 2023	Jun. 01, 2023	Jan. 07, 2024	Radiation (03CH04-KS)
Amplifier	SONOMA	310N	380827	9KHz-1GHz	Jul. 11, 2022	Jun. 01, 2023	Jul. 10, 2023	Radiation (03CH04-KS)
Amplifier	MITEQ	EM18G40G GA	060728	18~40GHz	Jan. 05, 2023	Jun. 01, 2023	Jan. 04, 2024	Radiation (03CH04-KS)
high gain Amplifier	EM	EM01G18G A	060840	1Ghz-18Ghz	Oct. 12, 2022	Jun. 01, 2023	Oct. 11, 2023	Radiation (03CH04-KS)
Amplifier	Agilent	8449B	3008A02370	1Ghz-18Ghz	Oct. 12, 2022	Jun. 01, 2023	Oct. 11, 2023	Radiation (03CH04-KS)
AC Power Source	Chroma	61601	F104090004	N/A	NCR	Jun. 01, 2023	NCR	Radiation (03CH04-KS)
Turn Table	ChamPro	EM 1000-T	060762-T	0~360 degree	NCR	Jun. 01, 2023	NCR	Radiation (03CH04-KS)
Antenna Mast	ChamPro	EM 1000-A	060762-A	1 m~4 m	NCR	Jun. 01, 2023	NCR	Radiation (03CH04-KS)

NCR: No Calibration Required



6 Measurement Uncertainty

The measurement uncertainties shown below were calculated in accordance with the requirements of ANSI 63.26-2015. All the measurement uncertainty value were shown with a coverage K=2 to indicate 95% level of confidence. The measurement data show herein meets or exceeds the CISPR measurement uncertainty values specified in CISPR 16-4-2 and can be compared directly to specified limit to determine compliance.

Uncertainty of Conducted Measurement

Test Item	Uncertainty
Conducted Power	±0.46 dB
Conducted Emissions	±0.48 dB
Occupied Channel Bandwidth	±0.1 %

Uncertainty of Radiated Emission Measurement (30 MHz ~ 1000 MHz)

Measuring Uncertainty for a Level of Confidence of 95% (U = 2Uc(y))	3.82 dB
---	---------

Uncertainty of Radiated Emission Measurement (1 GHz ~ 18 GHz)

Measuring Uncertainty for a Level of Confidence of 95% (U = 2Uc(y))	3.56 dB
---	---------

Uncertainty of Radiated Emission Measurement (18 GHz ~ 40 GHz)

Measuring Uncertainty for a Level of Confidence of 95% (U = 2Uc(y))	3.54 dB
---	---------

----- THE END -----



Appendix A. Test Results of Conducted Test

Test Engineer :	Simle Wang	Temperature :	22~23°C
		Relative Humidity :	40~42%

FR1 N41(Ant3) - Main PA

Transmitter Conducted Output Power And EIRP, (G_T - L_C)=-1.0dB

NR Band	SCS	BandWidth	Arfcn	Freq(MHz)	Modulation	RB	Conducted Power(dBm)	EIRP(dBm)	EIRP(W)
41	30	20	501204	2506.02	DFT-s-OFDM PI/2 BPSK	1@1	22.81	21.81	0.1517
41	30	20	501204	2506.02	DFT-s-OFDM QPSK	1@1	22.88	21.88	0.1542
41	30	20	501204	2506.02	DFT-s-OFDM 16 QAM	1@1	22.73	21.73	0.1489
41	30	20	518598	2592.99	DFT-s-OFDM PI/2 BPSK	1@1	22.79	21.79	0.1510
41	30	20	518598	2592.99	DFT-s-OFDM QPSK	1@1	22.84	21.84	0.1528
41	30	20	518598	2592.99	DFT-s-OFDM 16 QAM	1@1	22.69	21.69	0.1476
41	30	20	535998	2679.99	DFT-s-OFDM PI/2 BPSK	1@1	22.63	21.63	0.1455
41	30	20	535998	2679.99	DFT-s-OFDM QPSK	1@1	22.63	21.63	0.1455
41	30	20	535998	2679.99	DFT-s-OFDM 16 QAM	1@1	22.52	21.52	0.1419
41	30	30	502200	2511	DFT-s-OFDM PI/2 BPSK	1@1	22.89	21.89	0.1545
41	30	30	502200	2511	DFT-s-OFDM QPSK	1@1	22.87	21.87	0.1538
41	30	30	502200	2511	DFT-s-OFDM 16 QAM	1@1	22.8	21.8	0.1514
41	30	30	518598	2592.99	DFT-s-OFDM PI/2 BPSK	1@1	22.85	21.85	0.1531
41	30	30	518598	2592.99	DFT-s-OFDM QPSK	1@1	22.88	21.88	0.1542
41	30	30	518598	2592.99	DFT-s-OFDM 16 QAM	1@1	22.79	21.79	0.1510
41	30	30	534996	2674.98	DFT-s-OFDM PI/2 BPSK	1@1	22.73	21.73	0.1489
41	30	30	534996	2674.98	DFT-s-OFDM QPSK	1@1	22.74	21.74	0.1493
41	30	30	534996	2674.98	DFT-s-OFDM 16 QAM	1@1	22.65	21.65	0.1462
41	30	40	503202	2516.01	DFT-s-OFDM PI/2 BPSK	1@1	22.91	21.91	0.1552
41	30	40	503202	2516.01	DFT-s-OFDM QPSK	1@1	22.96	21.96	0.1570
41	30	40	503202	2516.01	DFT-s-OFDM 16 QAM	1@1	22.79	21.79	0.1510
41	30	40	518598	2592.99	DFT-s-OFDM PI/2 BPSK	1@1	22.94	21.94	0.1563
41	30	40	518598	2592.99	DFT-s-OFDM QPSK	1@1	22.97	21.97	0.1574
41	30	40	518598	2592.99	DFT-s-OFDM 16 QAM	1@1	22.81	21.81	0.1517
41	30	40	534000	2670	DFT-s-OFDM PI/2 BPSK	1@1	22.85	21.85	0.1531
41	30	40	534000	2670	DFT-s-OFDM QPSK	1@1	22.86	21.86	0.1535
41	30	40	534000	2670	DFT-s-OFDM 16 QAM	1@1	22.77	21.77	0.1503
41	30	50	504204	2521.02	DFT-s-OFDM PI/2 BPSK	1@1	22.85	21.85	0.1531
41	30	50	504204	2521.02	DFT-s-OFDM QPSK	1@1	22.83	21.83	0.1524
41	30	50	504204	2521.02	DFT-s-OFDM 16 QAM	1@1	22.78	21.78	0.1507
41	30	50	518598	2592.99	DFT-s-OFDM PI/2 BPSK	1@1	22.71	21.71	0.1483
41	30	50	518598	2592.99	DFT-s-OFDM QPSK	1@1	22.72	21.72	0.1486
41	30	50	518598	2592.99	DFT-s-OFDM 16 QAM	1@1	22.56	21.56	0.1432
41	30	50	532998	2664.99	DFT-s-OFDM PI/2 BPSK	1@1	22.65	21.65	0.1462
41	30	50	532998	2664.99	DFT-s-OFDM QPSK	1@1	22.66	21.66	0.1466
41	30	50	532998	2664.99	DFT-s-OFDM 16 QAM	1@1	22.52	21.52	0.1419
41	30	60	505200	2526	DFT-s-OFDM PI/2 BPSK	1@1	22.85	21.85	0.1531

41	30	60	505200	2526	DFT-s-OFDM QPSK	1@1	22.89	21.89	0.1545
41	30	60	505200	2526	DFT-s-OFDM 16 QAM	1@1	22.81	21.81	0.1517
41	30	60	518598	2592.99	DFT-s-OFDM PI/2 BPSK	1@1	22.7	21.7	0.1479
41	30	60	518598	2592.99	DFT-s-OFDM QPSK	1@1	22.74	21.74	0.1493
41	30	60	518598	2592.99	DFT-s-OFDM 16 QAM	1@1	22.63	21.63	0.1455
41	30	60	531996	2659.98	DFT-s-OFDM PI/2 BPSK	1@1	22.58	21.58	0.1439
41	30	60	531996	2659.98	DFT-s-OFDM QPSK	1@1	22.6	21.6	0.1445
41	30	60	531996	2659.98	DFT-s-OFDM 16 QAM	1@1	22.53	21.53	0.1422
41	30	70	505200	2531.01	DFT-s-OFDM PI/2 BPSK	1@1	22.73	21.73	0.1489
41	30	70	505200	2531.01	DFT-s-OFDM QPSK	1@1	22.73	21.73	0.1489
41	30	70	505200	2531.01	DFT-s-OFDM 16 QAM	1@1	22.71	21.71	0.1483
41	30	70	518598	2592.99	DFT-s-OFDM PI/2 BPSK	1@1	22.54	21.54	0.1426
41	30	70	518598	2592.99	DFT-s-OFDM QPSK	1@1	22.54	21.54	0.1426
41	30	70	518598	2592.99	DFT-s-OFDM 16 QAM	1@1	22.45	21.45	0.1396
41	30	70	531996	2655	DFT-s-OFDM PI/2 BPSK	1@1	22.49	21.49	0.1409
41	30	70	531996	2655	DFT-s-OFDM QPSK	1@1	22.48	21.48	0.1406
41	30	70	531996	2655	DFT-s-OFDM 16 QAM	1@1	22.39	21.39	0.1377
41	30	80	507204	2536.02	DFT-s-OFDM PI/2 BPSK	1@1	22.7	21.7	0.1479
41	30	80	507204	2536.02	DFT-s-OFDM QPSK	1@1	22.7	21.7	0.1479
41	30	80	507204	2536.02	DFT-s-OFDM 16 QAM	1@1	22.88	21.88	0.1542
41	30	80	518598	2592.99	DFT-s-OFDM PI/2 BPSK	1@1	22.59	21.59	0.1442
41	30	80	518598	2592.99	DFT-s-OFDM QPSK	1@1	22.52	21.52	0.1419
41	30	80	518598	2592.99	DFT-s-OFDM 16 QAM	1@1	22.45	21.45	0.1396
41	30	80	529998	2649.99	DFT-s-OFDM PI/2 BPSK	1@1	22.41	21.41	0.1384
41	30	80	529998	2649.99	DFT-s-OFDM QPSK	1@1	22.41	21.41	0.1384
41	30	80	529998	2649.99	DFT-s-OFDM 16 QAM	1@1	22.3	21.3	0.1349
41	30	90	508200	2541	DFT-s-OFDM PI/2 BPSK	1@1	22.72	21.72	0.1486
41	30	90	508200	2541	DFT-s-OFDM QPSK	1@1	22.76	21.76	0.1500
41	30	90	508200	2541	DFT-s-OFDM 16 QAM	1@1	22.51	21.51	0.1416
41	30	90	518598	2592.99	DFT-s-OFDM PI/2 BPSK	1@1	22.64	21.64	0.1459
41	30	90	518598	2592.99	DFT-s-OFDM QPSK	1@1	22.66	21.66	0.1466
41	30	90	518598	2592.99	DFT-s-OFDM 16 QAM	1@1	22.59	21.59	0.1442
41	30	90	528996	2644.98	DFT-s-OFDM PI/2 BPSK	1@1	22.37	21.37	0.1371
41	30	90	528996	2644.98	DFT-s-OFDM QPSK	1@1	22.43	21.43	0.1390
41	30	90	528996	2644.98	DFT-s-OFDM 16 QAM	1@1	22.29	21.29	0.1346
41	30	100	509202	2546.01	DFT-s-OFDM PI/2 BPSK	135@67	22.55	21.55	0.1429
41	30	100	509202	2546.01	DFT-s-OFDM PI/2 BPSK	1@1	22.79	21.79	0.1510
41	30	100	509202	2546.01	DFT-s-OFDM PI/2 BPSK	1@271	22.61	21.61	0.1449
41	30	100	509202	2546.01	DFT-s-OFDM QPSK	135@67	22.55	21.55	0.1429
41	30	100	509202	2546.01	DFT-s-OFDM QPSK	1@1	22.72	21.72	0.1486
41	30	100	509202	2546.01	DFT-s-OFDM QPSK	1@271	22.64	21.64	0.1459
41	30	100	509202	2546.01	DFT-s-OFDM 16 QAM	135@67	22.55	21.55	0.1429
41	30	100	509202	2546.01	DFT-s-OFDM 16 QAM	1@1	22.55	21.55	0.1429
41	30	100	509202	2546.01	DFT-s-OFDM 16 QAM	1@271	22.48	21.48	0.1406

41	30	100	509202	2546.01	DFT-s-OFDM 64 QAM	135@67	21.36	20.36	0.1086
41	30	100	509202	2546.01	DFT-s-OFDM 64 QAM	1@1	21.27	20.27	0.1064
41	30	100	509202	2546.01	DFT-s-OFDM 64 QAM	1@271	21.21	20.21	0.1050
41	30	100	509202	2546.01	DFT-s-OFDM 256 QAM	135@67	17.84	16.84	0.0483
41	30	100	509202	2546.01	DFT-s-OFDM 256 QAM	1@1	17.84	16.84	0.0483
41	30	100	509202	2546.01	DFT-s-OFDM 256 QAM	1@271	17.75	16.75	0.0473
41	30	100	509202	2546.01	CP-OFDM QPSK	137@68	22.28	21.28	0.1343
41	30	100	509202	2546.01	CP-OFDM QPSK	1@1	22.63	21.63	0.1455
41	30	100	509202	2546.01	CP-OFDM QPSK	1@271	22.58	21.58	0.1439
41	30	100	518598	2592.99	DFT-s-OFDM PI/2 BPSK	135@67	22.59	21.59	0.1442
41	30	100	518598	2592.99	DFT-s-OFDM PI/2 BPSK	1@1	22.69	21.69	0.1476
41	30	100	518598	2592.99	DFT-s-OFDM PI/2 BPSK	1@271	22.77	21.77	0.1503
41	30	100	518598	2592.99	DFT-s-OFDM QPSK	135@67	22.6	21.6	0.1445
41	30	100	518598	2592.99	DFT-s-OFDM QPSK	1@1	22.71	21.71	0.1483
41	30	100	518598	2592.99	DFT-s-OFDM QPSK	1@271	22.99	21.99	0.1581
41	30	100	518598	2592.99	DFT-s-OFDM 16 QAM	135@67	22.59	21.59	0.1442
41	30	100	518598	2592.99	DFT-s-OFDM 16 QAM	1@1	22.56	21.56	0.1432
41	30	100	518598	2592.99	DFT-s-OFDM 16 QAM	1@271	22.65	21.65	0.1462
41	30	100	518598	2592.99	DFT-s-OFDM 64 QAM	135@67	21.4	20.4	0.1096
41	30	100	518598	2592.99	DFT-s-OFDM 64 QAM	1@1	21.26	20.26	0.1062
41	30	100	518598	2592.99	DFT-s-OFDM 64 QAM	1@271	21.41	20.41	0.1099
41	30	100	518598	2592.99	DFT-s-OFDM 256 QAM	135@67	17.88	16.88	0.0488
41	30	100	518598	2592.99	DFT-s-OFDM 256 QAM	1@1	17.85	16.85	0.0484
41	30	100	518598	2592.99	DFT-s-OFDM 256 QAM	1@271	17.94	16.94	0.0494
41	30	100	518598	2592.99	CP-OFDM QPSK	137@68	22.36	21.36	0.1368
41	30	100	518598	2592.99	CP-OFDM QPSK	1@1	22.51	21.51	0.1416
41	30	100	518598	2592.99	CP-OFDM QPSK	1@271	22.57	21.57	0.1435
41	30	100	528000	2640	DFT-s-OFDM PI/2 BPSK	135@67	22.63	21.63	0.1455
41	30	100	528000	2640	DFT-s-OFDM PI/2 BPSK	1@1	22.49	21.49	0.1409
41	30	100	528000	2640	DFT-s-OFDM PI/2 BPSK	1@271	22.66	21.66	0.1466
41	30	100	528000	2640	DFT-s-OFDM QPSK	135@67	22.67	21.67	0.1469
41	30	100	528000	2640	DFT-s-OFDM QPSK	1@1	22.46	21.46	0.1400
41	30	100	528000	2640	DFT-s-OFDM QPSK	1@271	22.65	21.65	0.1462
41	30	100	528000	2640	DFT-s-OFDM 16 QAM	135@67	22.63	21.63	0.1455
41	30	100	528000	2640	DFT-s-OFDM 16 QAM	1@1	22.34	21.34	0.1361
41	30	100	528000	2640	DFT-s-OFDM 16 QAM	1@271	22.57	21.57	0.1435
41	30	100	528000	2640	DFT-s-OFDM 64 QAM	135@67	21.43	20.43	0.1104
41	30	100	528000	2640	DFT-s-OFDM 64 QAM	1@1	21.07	20.07	0.1016
41	30	100	528000	2640	DFT-s-OFDM 64 QAM	1@271	21.34	20.34	0.1081
41	30	100	528000	2640	DFT-s-OFDM 256 QAM	135@67	17.92	16.92	0.0492
41	30	100	528000	2640	DFT-s-OFDM 256 QAM	1@1	17.63	16.63	0.0460
41	30	100	528000	2640	DFT-s-OFDM 256 QAM	1@271	17.81	16.81	0.0480
41	30	100	528000	2640	CP-OFDM QPSK	137@68	22.39	21.39	0.1377
41	30	100	528000	2640	CP-OFDM QPSK	1@1	22.27	21.27	0.1340

41	30	100	528000	2640	CP-OFDM QPSK	1@271	22.46	21.46	0.1400
----	----	-----	--------	------	--------------	-------	-------	-------	--------

Frequency Stability

NR Band	SCS (kHz)	Bandwidth (MHz)	Arfcn	Freq (MHz)	Modulation	RB	Deviation (ppm)	Verdict	Environment
41	30	20	518598	2592.99	DFT-s-OFDM QPSK	50@0	-0.0032	PASS	NV
41	30	20	518598	2592.99	DFT-s-OFDM QPSK	50@0	0.0024	PASS	LV
41	30	20	518598	2592.99	DFT-s-OFDM QPSK	50@0	0.0021	PASS	HV
41	30	20	518598	2592.99	DFT-s-OFDM QPSK	50@0	0.0013	PASS	-30°C
41	30	20	518598	2592.99	DFT-s-OFDM QPSK	50@0	0.0022	PASS	-20°C
41	30	20	518598	2592.99	DFT-s-OFDM QPSK	50@0	0.0016	PASS	-10°C
41	30	20	518598	2592.99	DFT-s-OFDM QPSK	50@0	-0.0021	PASS	0°C
41	30	20	518598	2592.99	DFT-s-OFDM QPSK	50@0	0.0029	PASS	10°C
41	30	20	518598	2592.99	DFT-s-OFDM QPSK	50@0	0.0026	PASS	20°C
41	30	20	518598	2592.99	DFT-s-OFDM QPSK	50@0	0.0025	PASS	30°C
41	30	20	518598	2592.99	DFT-s-OFDM QPSK	50@0	-0.0011	PASS	40°C
41	30	20	518598	2592.99	DFT-s-OFDM QPSK	50@0	0.0014	PASS	50°C

Peak to Average Ratio

NR Band	SCS (kHz)	Bandwidth (MHz)	Arfcn	Freq (MHz)	Modulation	RB	Result (dB)	Limit (dB)	Verdict
41	30	100	518598	2592.99	DFT-s-OFDM PI/2 BPSK	270@0	10.14	13	PASS
41	30	100	518598	2592.99	DFT-s-OFDM PI/2 BPSK	1@0	6.67	13	PASS
41	30	100	518598	2592.99	DFT-s-OFDM QPSK	270@0	10.43	13	PASS
41	30	100	518598	2592.99	DFT-s-OFDM QPSK	1@0	7.47	13	PASS

N41(100M)_DFT-s-OFDM_PI_2-BPSK_Outer_Full_Mid_CH



N41(100M)_DFT-s-OFDM_PI_2-BPSK_Edge_1RB_Left_Mid_CH

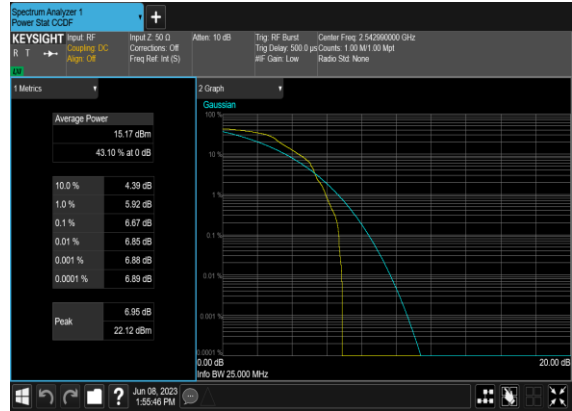

N41(100M)_DFT-s-OFDM_QPSK_Outer_Full_Mid_CH



N41(100M)_DFT-s-OFDM_QPSK_Edge_1RB_Left_Mid_CH

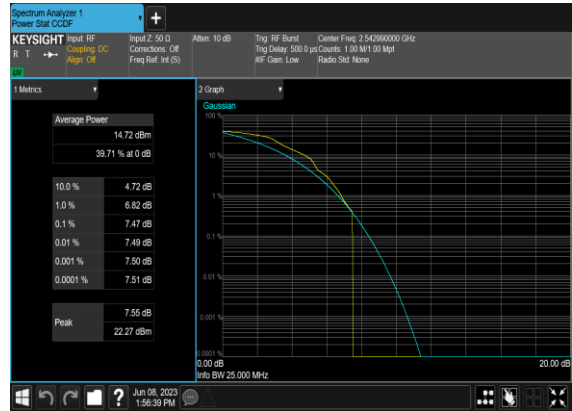

Occupied Bandwidth

NR Band	SCS (kHz)	Bandwidth (MHz)	Arfcn	Freq (MHz)	Modulation	RB	OBW (MHz)	26dB BW (MHz)
41	30	20	518598	2592.99	CP-OFDM QPSK	51@0	18.215	19.22
41	30	20	518598	2592.99	CP-OFDM 16 QAM	51@0	18.207	19.3
41	30	20	518598	2592.99	CP-OFDM 64 QAM	51@0	18.2	19.34
41	30	20	518598	2592.99	CP-OFDM 256 QAM	51@0	18.18	19.1
41	30	30	518598	2592.99	CP-OFDM QPSK	78@0	27.839	29.34
41	30	30	518598	2592.99	CP-OFDM 16 QAM	78@0	27.766	29.62
41	30	30	518598	2592.99	CP-OFDM 64 QAM	78@0	27.856	29.13
41	30	30	518598	2592.99	CP-OFDM 256 QAM	78@0	27.868	29.16
41	30	40	518598	2592.99	CP-OFDM QPSK	106@0	37.831	39.9
41	30	40	518598	2592.99	CP-OFDM 16 QAM	106@0	37.801	39.46
41	30	40	518598	2592.99	CP-OFDM 64 QAM	106@0	37.801	39.25
41	30	40	518598	2592.99	CP-OFDM 256 QAM	106@0	37.861	39.74
41	30	50	518598	2592.99	CP-OFDM QPSK	133@0	47.411	49.15
41	30	50	518598	2592.99	CP-OFDM 16 QAM	133@0	47.48	49.2
41	30	50	518598	2592.99	CP-OFDM 64 QAM	133@0	47.452	49.22
41	30	50	518598	2592.99	CP-OFDM 256 QAM	133@0	47.466	49.04
41	30	60	518598	2592.99	CP-OFDM QPSK	162@0	57.819	59.8
41	30	60	518598	2592.99	CP-OFDM 16 QAM	162@0	57.741	59.77
41	30	60	518598	2592.99	CP-OFDM 64 QAM	162@0	57.909	59.77
41	30	60	518598	2592.99	CP-OFDM 256 QAM	162@0	57.812	59.98
41	30	70	518598	2592.99	CP-OFDM QPSK	189@0	67.425	69.56
41	30	70	518598	2592.99	CP-OFDM 16 QAM	189@0	67.387	69.69
41	30	70	518598	2592.99	CP-OFDM 64 QAM	189@0	67.444	69.52
41	30	70	518598	2592.99	CP-OFDM 256 QAM	189@0	67.448	69.62
41	30	80	518598	2592.99	CP-OFDM QPSK	217@0	77.45	79.88
41	30	80	518598	2592.99	CP-OFDM 16 QAM	217@0	77.43	79.83

41	30	80	518598	2592.99	CP-OFDM 64 QAM	217@0	77.645	79.86
41	30	80	518598	2592.99	CP-OFDM 256 QAM	217@0	77.414	80.02
41	30	90	518598	2592.99	CP-OFDM QPSK	245@0	87.426	90.36
41	30	90	518598	2592.99	CP-OFDM 16 QAM	245@0	87.394	90.24
41	30	90	518598	2592.99	CP-OFDM 64 QAM	245@0	87.396	90.31
41	30	90	518598	2592.99	CP-OFDM 256 QAM	245@0	87.488	90.15
41	30	100	518598	2592.99	CP-OFDM QPSK	273@0	97.474	100.6
41	30	100	518598	2592.99	CP-OFDM 16 QAM	273@0	97.536	100.5
41	30	100	518598	2592.99	CP-OFDM 64 QAM	273@0	97.438	100.4
41	30	100	518598	2592.99	CP-OFDM 256 QAM	273@0	97.591	100.4

N41(20M)_CP-OFDM_QPSK_Outer_Full_Mid_CH

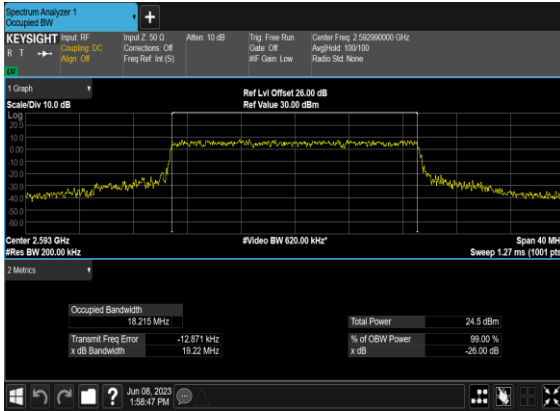

N41(20M)_CP-OFDM_16QAM_Outer_Full_Mid_CH

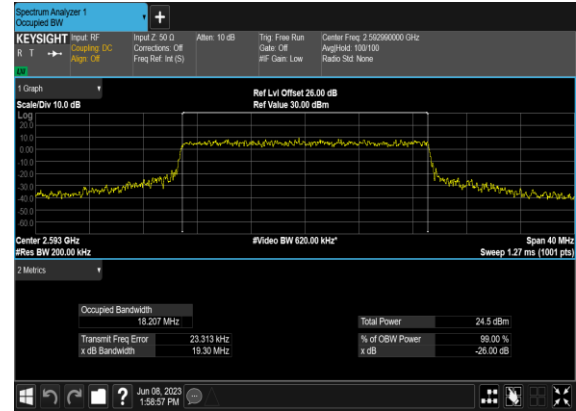

N41(20M)_CP-OFDM_64QAM_Outer_Full_Mid_CH

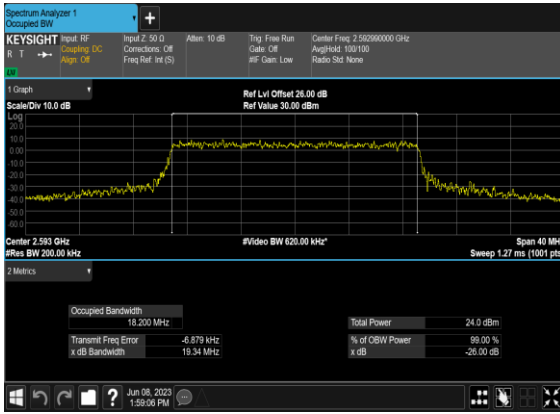

N41(20M)_CP-OFDM_256QAM_Outer_Full_Mid_CH

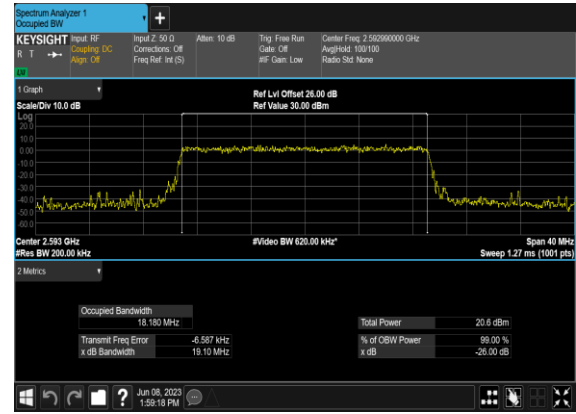

N41(30M)_CP-OFDM_QPSK_Outer_Full_Mid_CH

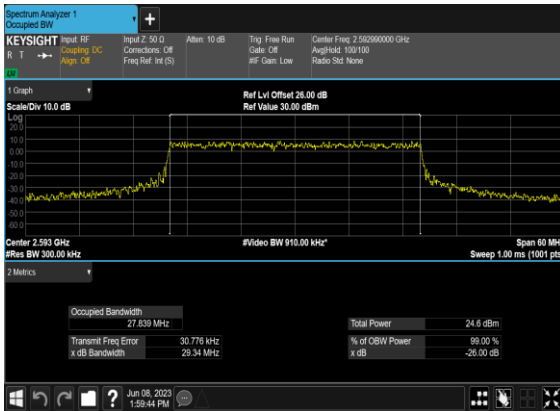

N41(30M)_CP-OFDM_16QAM_Outer_Full_Mid_CH

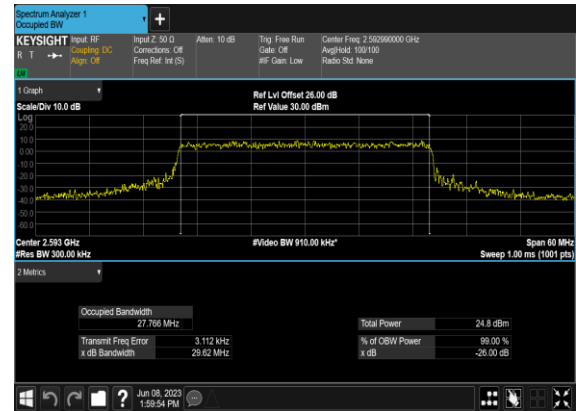

N41(30M)_CP-OFDM_64 QAM_Outer_Full_Mid_CH

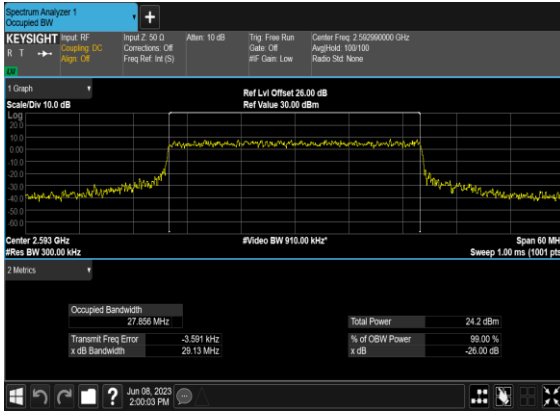

N41(30M)_CP-OFDM_256 QAM_Outer_Full_Mid_CH

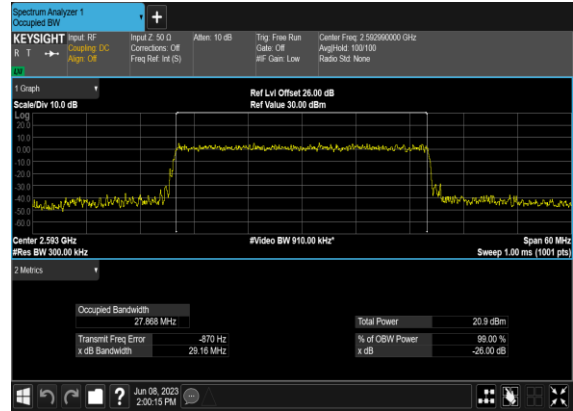

N41(40M)_CP- OFDM_QPSK_Outer_Full_Mid_CH

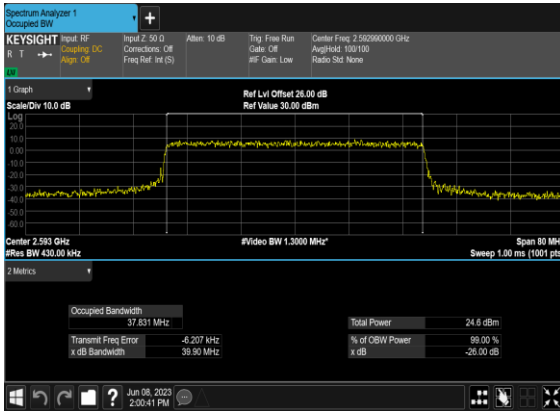

N41(40M)_CP-OFDM_16 QAM_Outer_Full_Mid_CH



N41(40M)_CP-OFDM_64 QAM_Outer_Full_Mid_CH

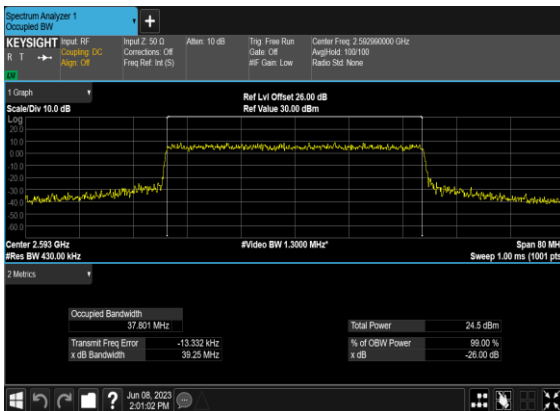

N41(40M)_CP-OFDM_256 QAM_Outer_Full_Mid_CH

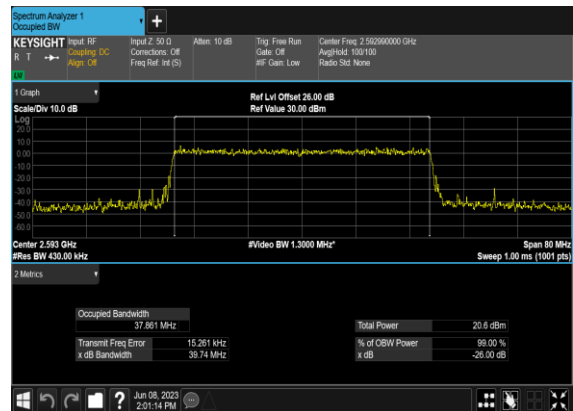

N41(50M)_CP-OFDM_QPSK_Outer_Full_Mid_CH



N41(50M)_CP-OFDM_16QAM_Outer_Full_Mid_CH

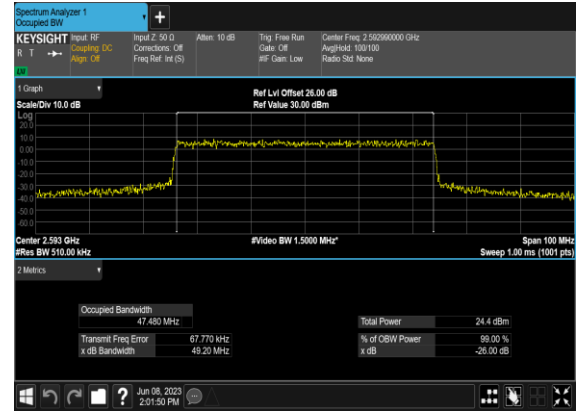

N41(50M)_CP-OFDM_64QAM_Outer_Full_Mid_CH

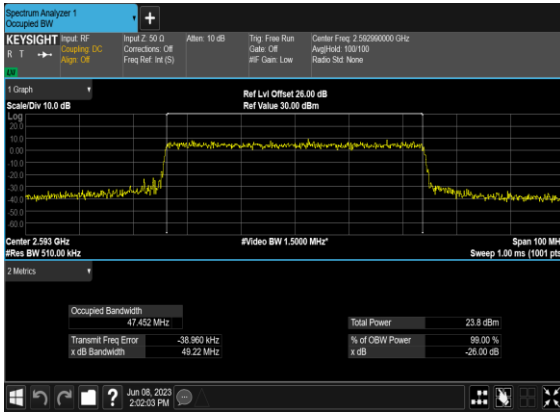

N41(50M)_CP-OFDM_256QAM_Outer_Full_Mid_CH



N41(60M)_CP-OFDM_QPSK_Outer_Full_Mid_CH

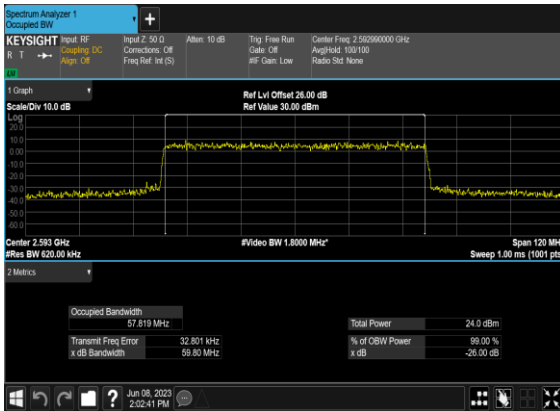

N41(60M)_CP-OFDM_16QAM_Outer_Full_Mid_CH

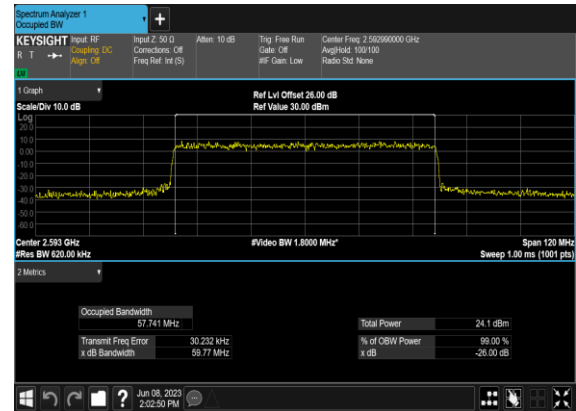

N41(60M)_CP-OFDM_64
QAM_Outer_Full_Mid_CH

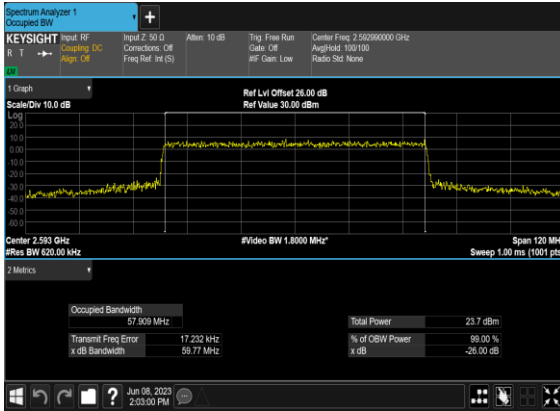

N41(60M)_CP-OFDM_256
QAM_Outer_Full_Mid_CH

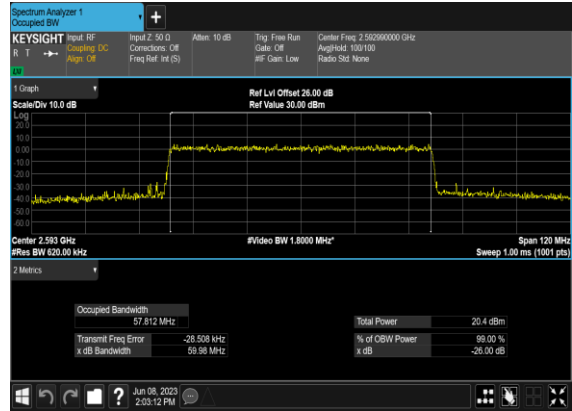

N41(70M)_CP-
OFDM_QPSK_Outer_Full_Mid_CH



N41(70M)_CP-OFDM_16
QAM_Outer_Full_Mid_CH

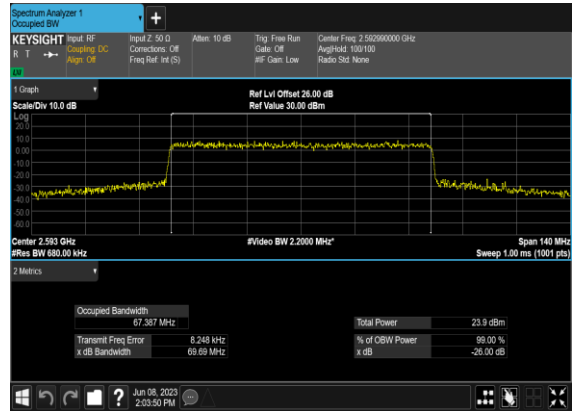

N41(70M)_CP-OFDM_64
QAM_Outer_Full_Mid_CH

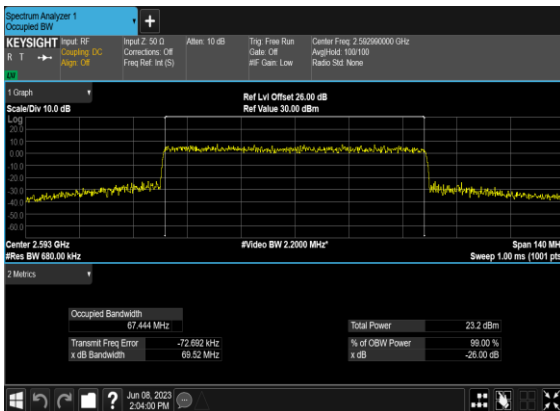

N41(70M)_CP-OFDM_256
QAM_Outer_Full_Mid_CH

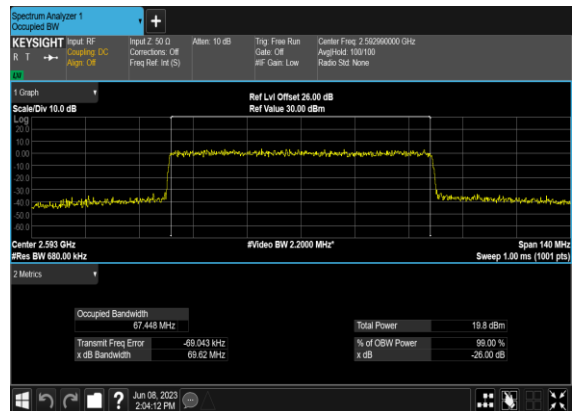

N41(80M)_CP- OFDM_QPSK_Outer_Full_Mid_CH

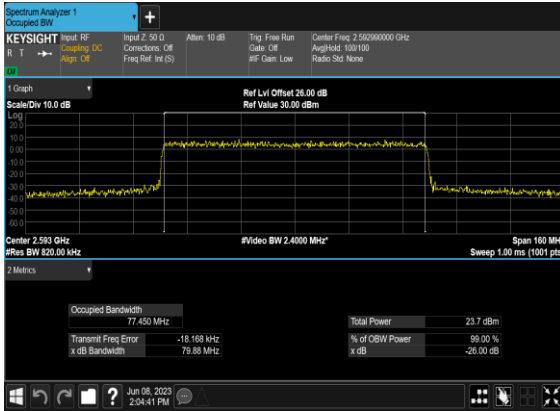

N41(80M)_CP-OFDM_16 QAM_Outer_Full_Mid_CH

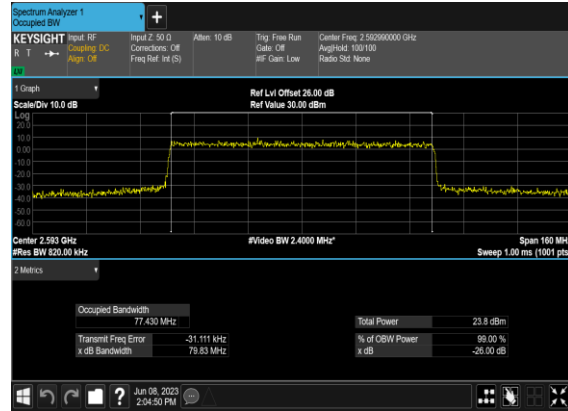

N41(80M)_CP-OFDM_64 QAM_Outer_Full_Mid_CH

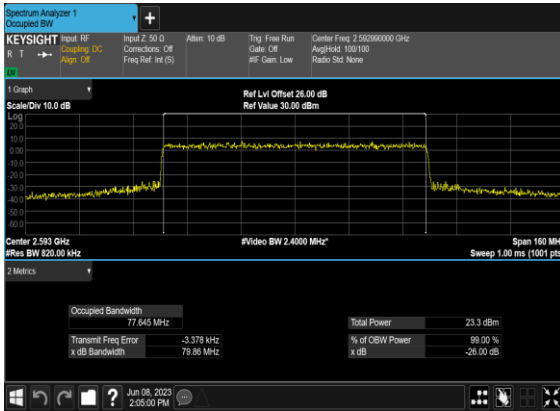

N41(80M)_CP-OFDM_256 QAM_Outer_Full_Mid_CH

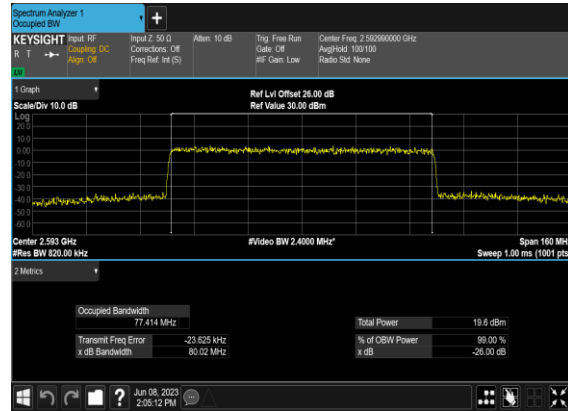

N41(90M)_CP- OFDM_QPSK_Outer_Full_Mid_CH

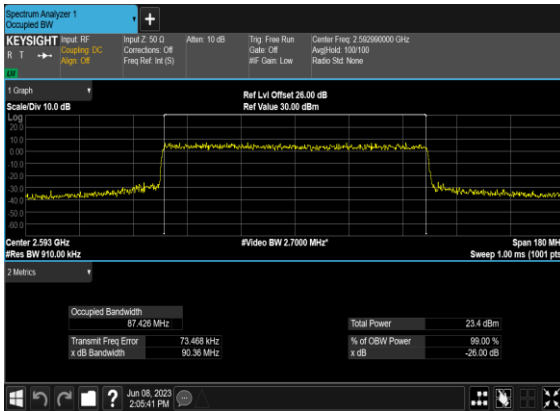

N41(90M)_CP-OFDM_16 QAM_Outer_Full_Mid_CH

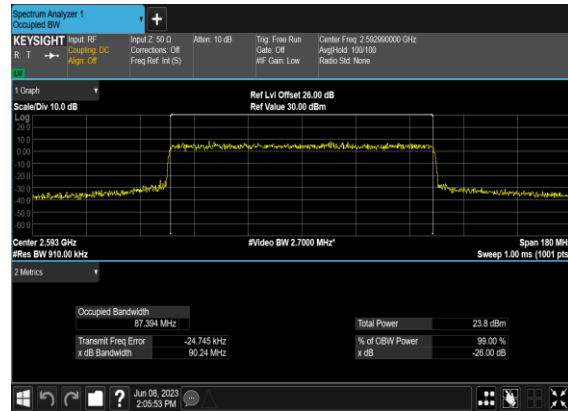

N41(90M)_CP-OFDM_64 QAM_Outer_Full_Mid_CH

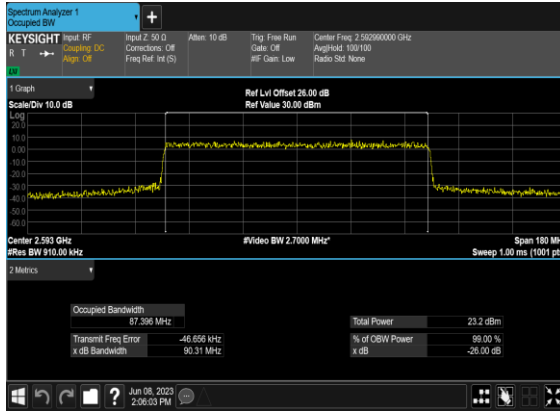

N41(90M)_CP-OFDM_256 QAM_Outer_Full_Mid_CH

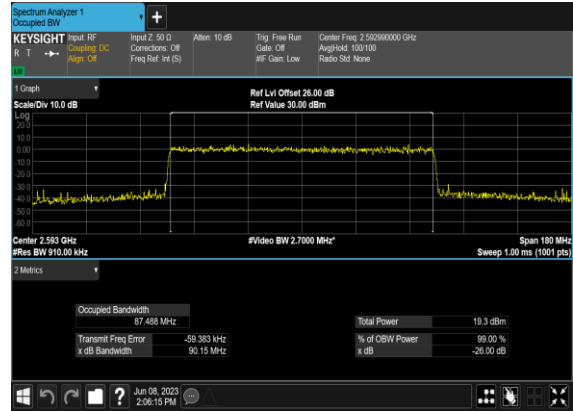

N41(100M)_CP- OFDM_QPSK_Outer_Full_Mid_CH

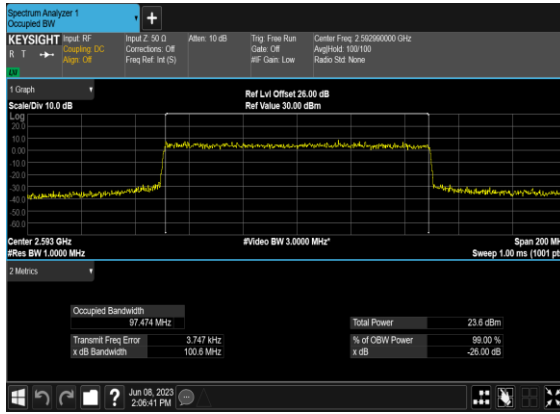

N41(100M)_CP-OFDM_16 QAM_Outer_Full_Mid_CH

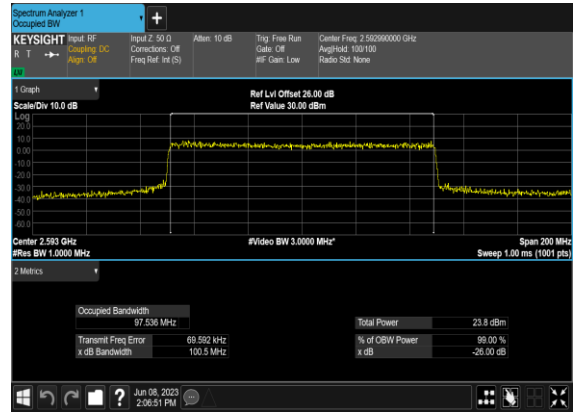

N41(100M)_CP-OFDM_64 QAM_Outer_Full_Mid_CH

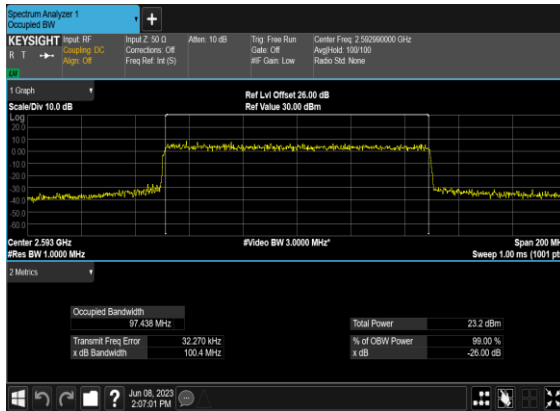

N41(100M)_CP-OFDM_256 QAM_Outer_Full_Mid_CH

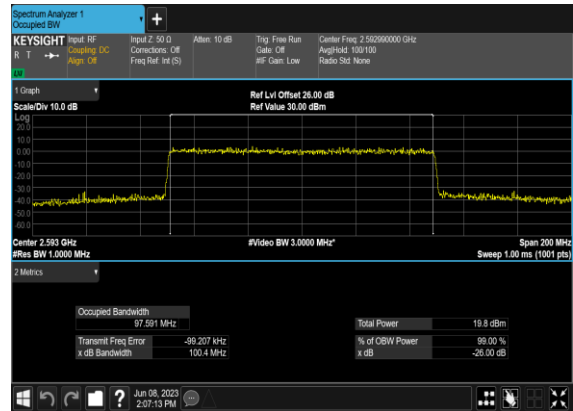

Conducted Spurious Emissions

NR Band	SCS (kHz)	Bandwidth (MHz)	Arfcn	Freq (MHz)	Modulation	RB	Result	Verdict
41	30	20	501204	2506.02	DFT-s-OFDM BPSK	1@0	see graph	---
41	30	20	501204	2506.02	DFT-s-OFDM BPSK	1@0	see graph	PASS
41	30	20	501204	2506.02	DFT-s-OFDM BPSK	1@0	see graph	PASS
41	30	20	501204	2506.02	DFT-s-OFDM QPSK	1@0	see graph	---
41	30	20	501204	2506.02	DFT-s-OFDM QPSK	1@0	see graph	PASS
41	30	20	501204	2506.02	DFT-s-OFDM QPSK	1@0	see graph	PASS
41	30	20	518598	2592.99	DFT-s-OFDM BPSK	1@0	see graph	---
41	30	20	518598	2592.99	DFT-s-OFDM BPSK	1@0	see graph	PASS
41	30	20	518598	2592.99	DFT-s-OFDM BPSK	1@0	see graph	PASS
41	30	20	518598	2592.99	DFT-s-OFDM QPSK	1@0	see graph	---
41	30	20	518598	2592.99	DFT-s-OFDM QPSK	1@0	see graph	PASS
41	30	20	518598	2592.99	DFT-s-OFDM QPSK	1@0	see graph	PASS
41	30	20	535998	2679.99	DFT-s-OFDM BPSK	1@0	see graph	---
41	30	20	535998	2679.99	DFT-s-OFDM BPSK	1@0	see graph	PASS
41	30	20	535998	2679.99	DFT-s-OFDM BPSK	1@0	see graph	PASS
41	30	20	535998	2679.99	DFT-s-OFDM QPSK	1@0	see graph	---
41	30	20	535998	2679.99	DFT-s-OFDM QPSK	1@0	see graph	PASS
41	30	20	535998	2679.99	DFT-s-OFDM QPSK	1@0	see graph	PASS
41	30	60	505200	2526.0	DFT-s-OFDM BPSK	1@0	see graph	---
41	30	60	505200	2526.0	DFT-s-OFDM BPSK	1@0	see graph	PASS
41	30	60	505200	2526.0	DFT-s-OFDM BPSK	1@0	see graph	PASS

41	30	60	505200	2526.0	DFT-s-OFDM QPSK	1@0	see graph	---
41	30	60	505200	2526.0	DFT-s-OFDM QPSK	1@0	see graph	PASS
41	30	60	505200	2526.0	DFT-s-OFDM QPSK	1@0	see graph	PASS
41	30	60	518598	2592.99	DFT-s-OFDM BPSK	1@0	see graph	---
41	30	60	518598	2592.99	DFT-s-OFDM BPSK	1@0	see graph	PASS
41	30	60	518598	2592.99	DFT-s-OFDM BPSK	1@0	see graph	PASS
41	30	60	518598	2592.99	DFT-s-OFDM QPSK	1@0	see graph	---
41	30	60	518598	2592.99	DFT-s-OFDM QPSK	1@0	see graph	PASS
41	30	60	518598	2592.99	DFT-s-OFDM QPSK	1@0	see graph	PASS
41	30	60	531996	2659.98	DFT-s-OFDM BPSK	1@0	see graph	---
41	30	60	531996	2659.98	DFT-s-OFDM BPSK	1@0	see graph	PASS
41	30	60	531996	2659.98	DFT-s-OFDM BPSK	1@0	see graph	PASS
41	30	60	531996	2659.98	DFT-s-OFDM QPSK	1@0	see graph	---
41	30	60	531996	2659.98	DFT-s-OFDM QPSK	1@0	see graph	PASS
41	30	60	531996	2659.98	DFT-s-OFDM QPSK	1@0	see graph	PASS
41	30	100	509202	2546.01	DFT-s-OFDM BPSK	1@0	see graph	---
41	30	100	509202	2546.01	DFT-s-OFDM BPSK	1@0	see graph	PASS
41	30	100	509202	2546.01	DFT-s-OFDM BPSK	1@0	see graph	PASS
41	30	100	509202	2546.01	DFT-s-OFDM QPSK	1@0	see graph	---
41	30	100	509202	2546.01	DFT-s-OFDM QPSK	1@0	see graph	PASS
41	30	100	509202	2546.01	DFT-s-OFDM QPSK	1@0	see graph	PASS
41	30	100	518598	2592.99	DFT-s-OFDM BPSK	1@0	see graph	---
41	30	100	518598	2592.99	DFT-s-OFDM BPSK	1@0	see graph	PASS
41	30	100	518598	2592.99	DFT-s-OFDM BPSK	1@0	see graph	PASS

41	30	100	518598	2592.99	DFT-s-OFDM QPSK	1@0	see graph	---
41	30	100	518598	2592.99	DFT-s-OFDM QPSK	1@0	see graph	PASS
41	30	100	518598	2592.99	DFT-s-OFDM QPSK	1@0	see graph	PASS
41	30	100	528000	2640.0	DFT-s-OFDM BPSK	1@0	see graph	---
41	30	100	528000	2640.0	DFT-s-OFDM BPSK	1@0	see graph	PASS
41	30	100	528000	2640.0	DFT-s-OFDM BPSK	1@0	see graph	PASS
41	30	100	528000	2640.0	DFT-s-OFDM QPSK	1@0	see graph	---
41	30	100	528000	2640.0	DFT-s-OFDM QPSK	1@0	see graph	PASS
41	30	100	528000	2640.0	DFT-s-OFDM QPSK	1@0	see graph	PASS

N41(20M)_DFT-s-OFDM_BPSK_Edge_1RB_Left_Low_CH

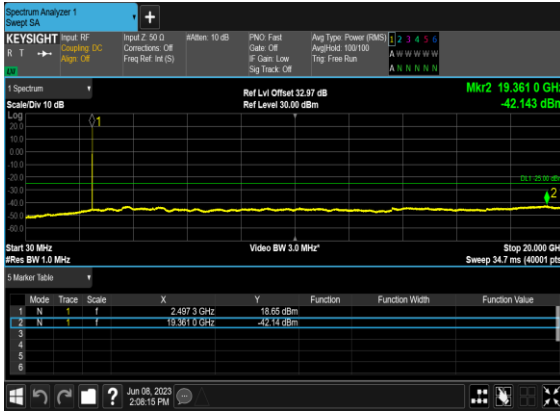

N41(20M)_DFT-s-OFDM_BPSK_Edge_1RB_Left_Low_CH

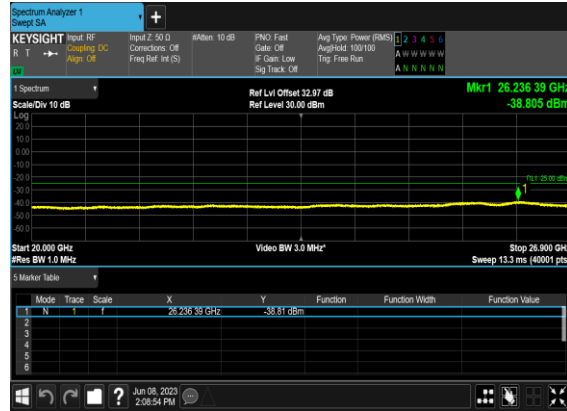

N41(20M)_DFT-s-OFDM_QPSK_Edge_1RB_Left_Low_CH

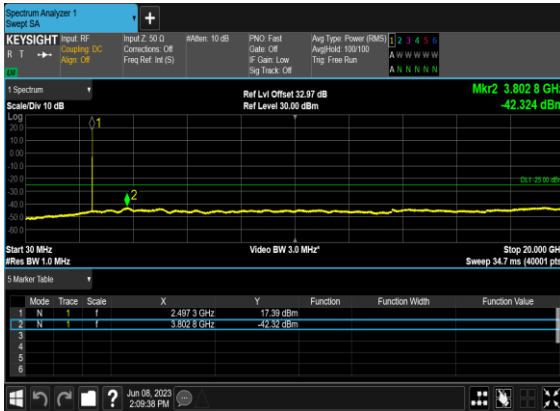

N41(20M)_DFT-s-OFDM_QPSK_Edge_1RB_Left_Low_CH

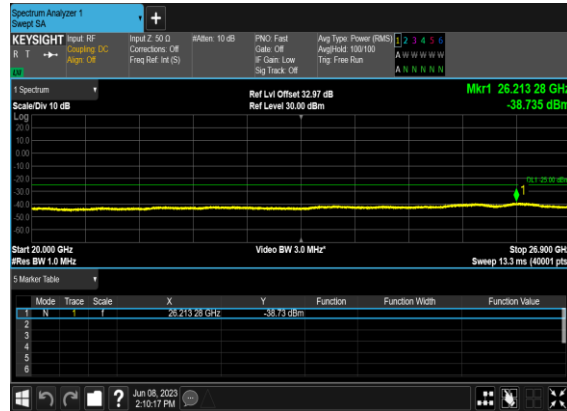

N41(20M)_DFT-s-OFDM_BPSK_Edge_1RB_Left_Mid_CH

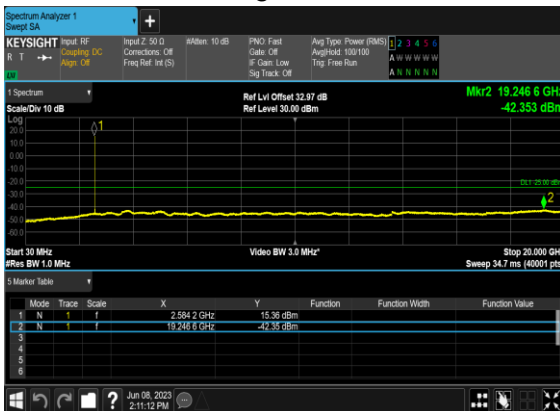

N41(20M)_DFT-s-OFDM_BPSK_Edge_1RB_Left_Mid_CH

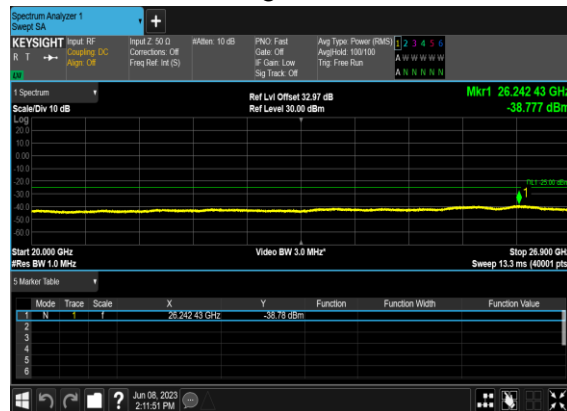

N41(20M)_DFT-s-OFDM_QPSK_Edge_1RB_Left_Mid_CH

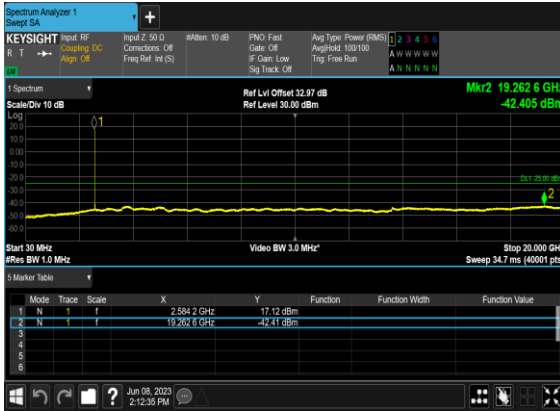

N41(20M)_DFT-s-OFDM_QPSK_Edge_1RB_Left_Mid_CH

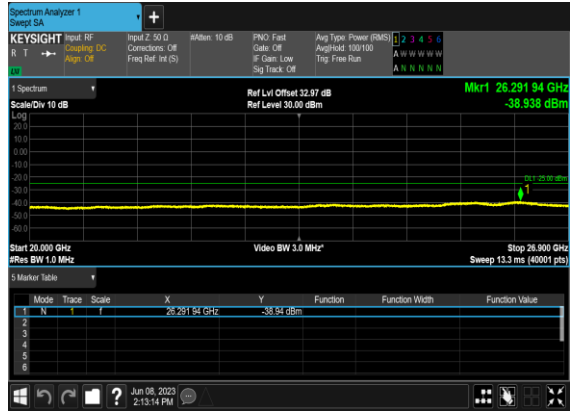

N41(20M)_DFT-s-OFDM_BPSK_Edge_1RB_Left_High_CH

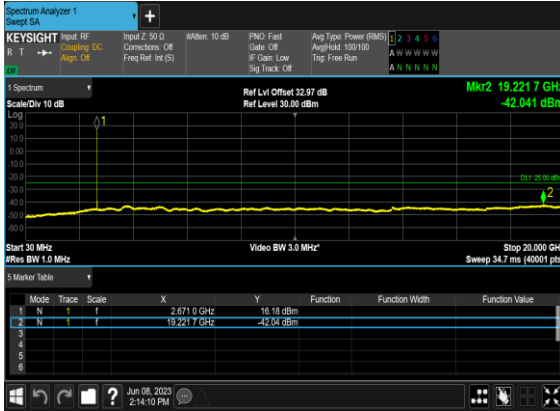

N41(20M)_DFT-s-OFDM_BPSK_Edge_1RB_Left_High_CH

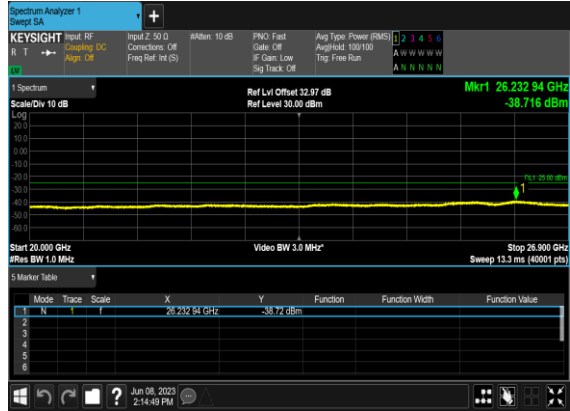

N41(20M)_DFT-s-OFDM_QPSK_Edge_1RB_Left_High_CH

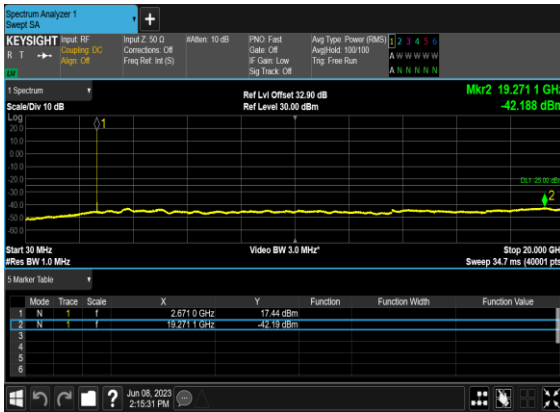

N41(20M)_DFT-s-OFDM_QPSK_Edge_1RB_Left_High_CH

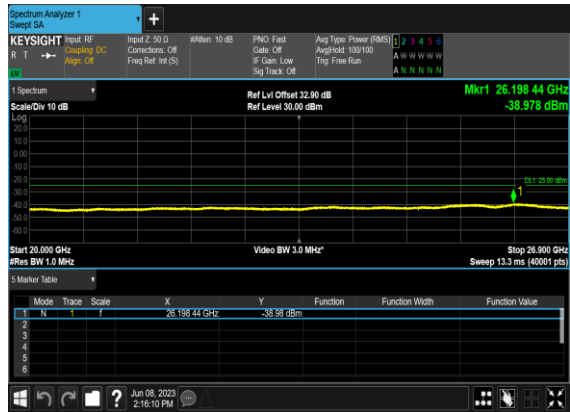

N41(60M)_DFT-s-OFDM_BPSK_Edge_1RB_Left_Low_CH

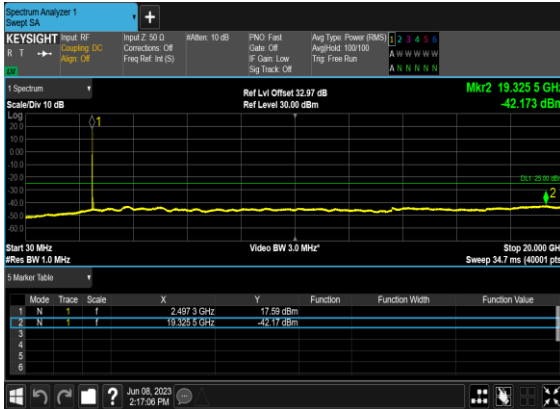

N41(60M)_DFT-s-OFDM_BPSK_Edge_1RB_Left_Low_CH

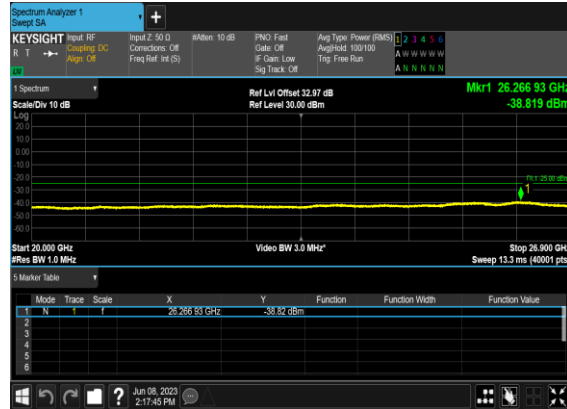

N41(60M)_DFT-s-OFDM_QPSK_Edge_1RB_Left_Low_CH

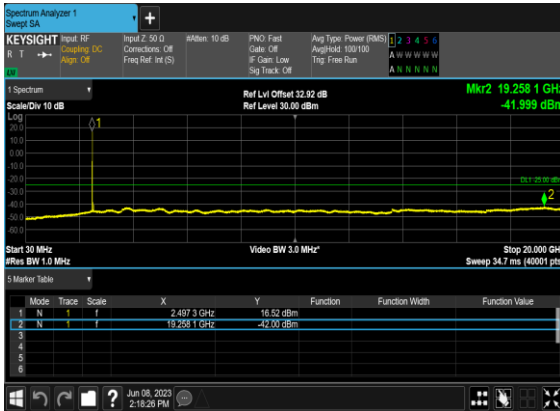

N41(60M)_DFT-s-OFDM_QPSK_Edge_1RB_Left_Low_CH

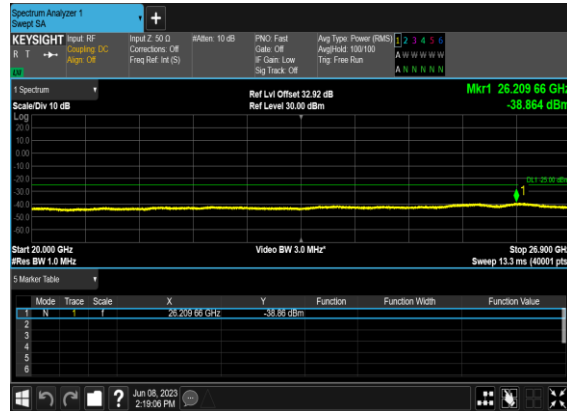

N41(60M)_DFT-s-OFDM_BPSK_Edge_1RB_Left_Mid_CH

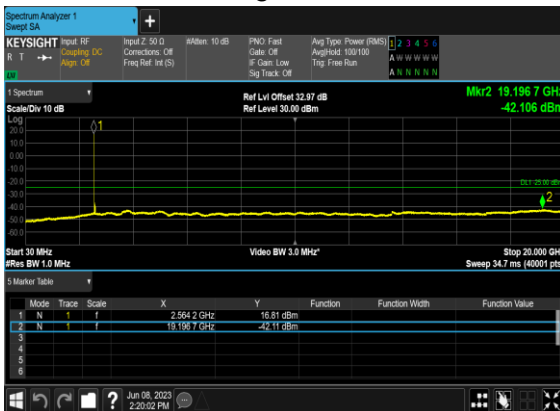

N41(60M)_DFT-s-OFDM_BPSK_Edge_1RB_Left_Mid_CH

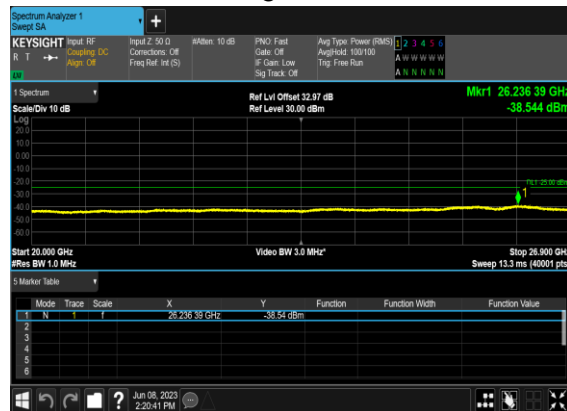

N41(60M)_DFT-s-OFDM_QPSK_Edge_1RB_Left_Mid_CH

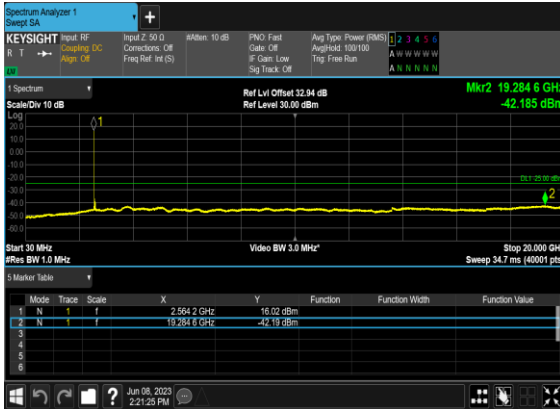

N41(60M)_DFT-s-OFDM_QPSK_Edge_1RB_Left_Mid_CH

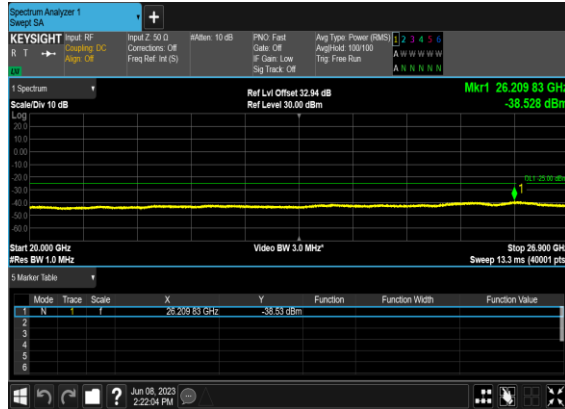

N41(60M)_DFT-s-OFDM_BPSK_Edge_1RB_Left_High_CH

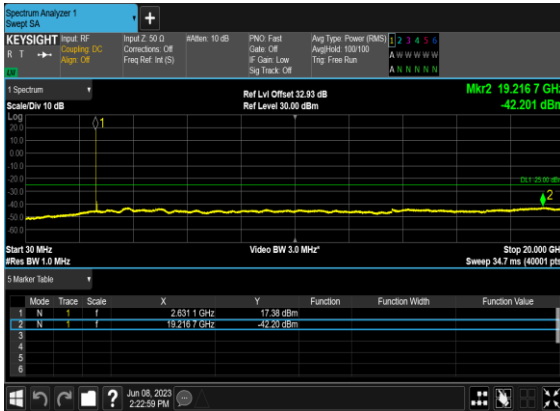

N41(60M)_DFT-s-OFDM_BPSK_Edge_1RB_Left_High_CH

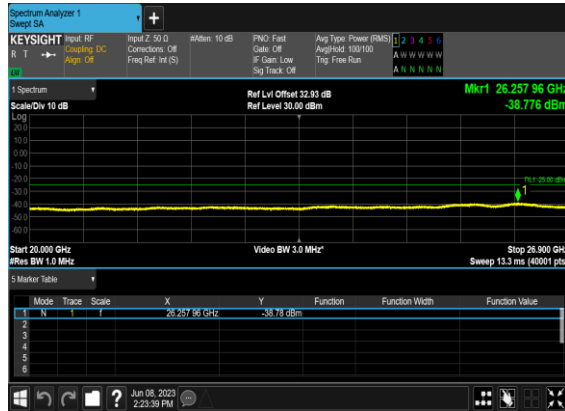

N41(60M)_DFT-s-OFDM_QPSK_Edge_1RB_Left_High_CH

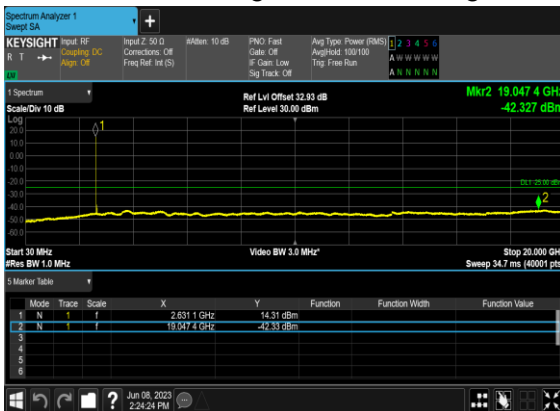

N41(60M)_DFT-s-OFDM_QPSK_Edge_1RB_Left_High_CH

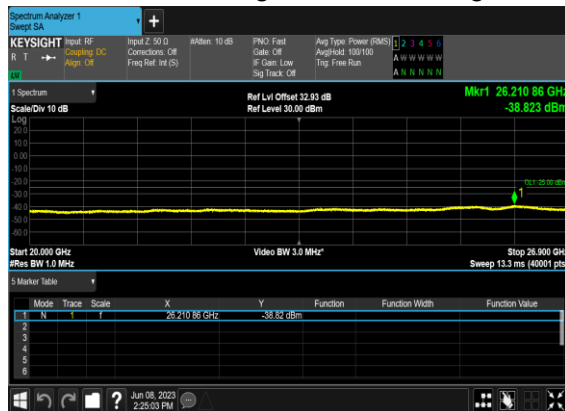

N41(100M)_DFT-s-OFDM_BPSK_Edge_1RB_Left_Low_CH

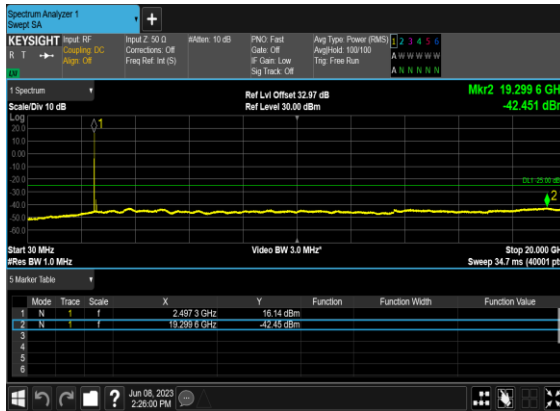

N41(100M)_DFT-s-OFDM_BPSK_Edge_1RB_Left_Low_CH



N41(100M)_DFT-s-OFDM_QPSK_Edge_1RB_Left_Low_CH

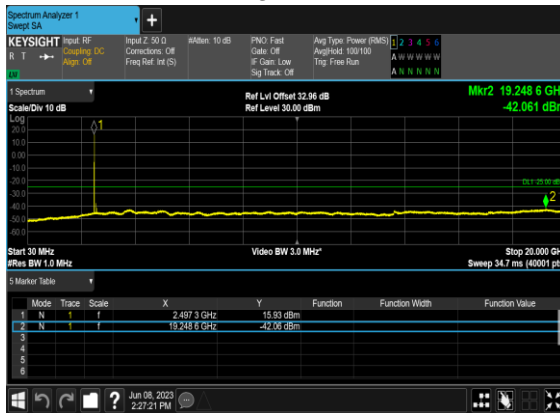

N41(100M)_DFT-s-OFDM_QPSK_Edge_1RB_Left_Low_CH



N41(100M)_DFT-s-OFDM_BPSK_Edge_1RB_Left_Mid_CH

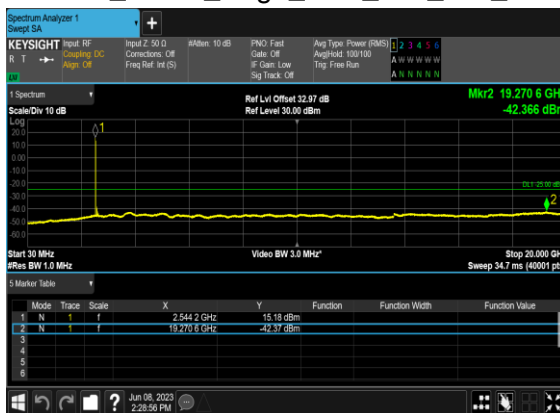

N41(100M)_DFT-s-OFDM_BPSK_Edge_1RB_Left_Mid_CH

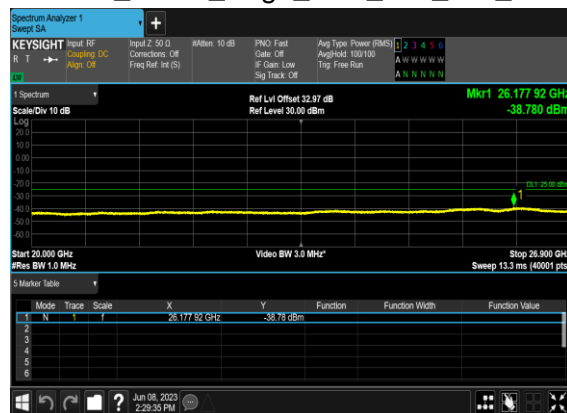

N41(100M)_DFT-s-OFDM_QPSK_Edge_1RB_Left_Mid_CH

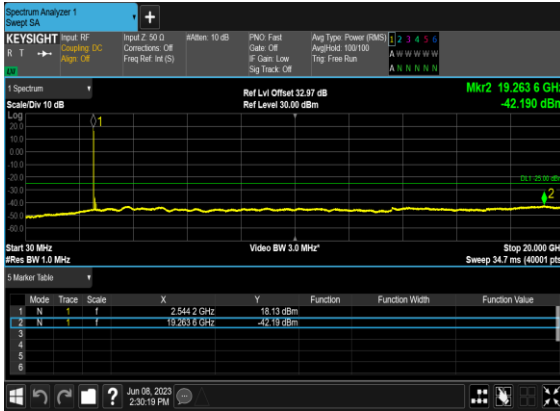

N41(100M)_DFT-s-OFDM_QPSK_Edge_1RB_Left_Mid_CH

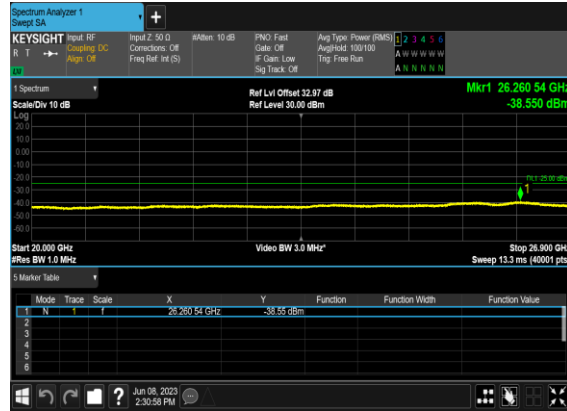

N41(100M)_DFT-s-OFDM_BPSK_Edge_1RB_Left_High_CH

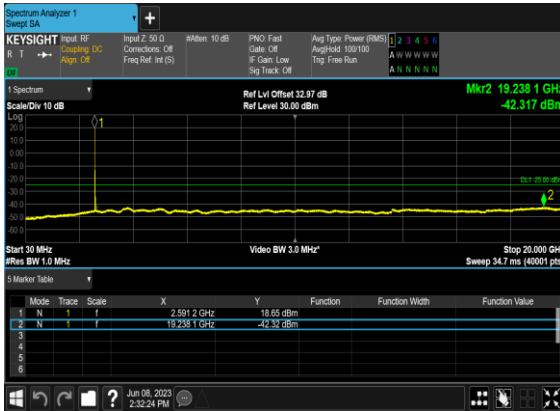

N41(100M)_DFT-s-OFDM_BPSK_Edge_1RB_Left_High_CH

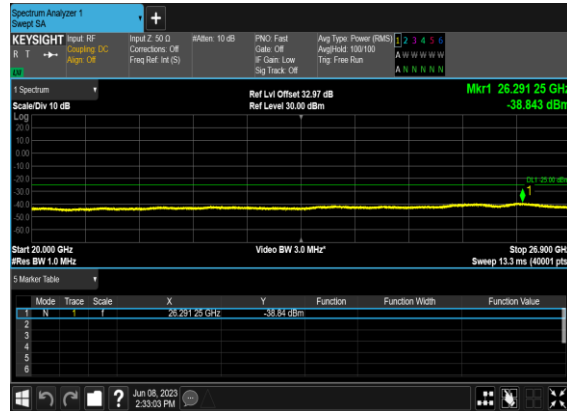

N41(100M)_DFT-s-OFDM_QPSK_Edge_1RB_Left_High_CH



N41(100M)_DFT-s-OFDM_QPSK_Edge_1RB_Left_High_CH

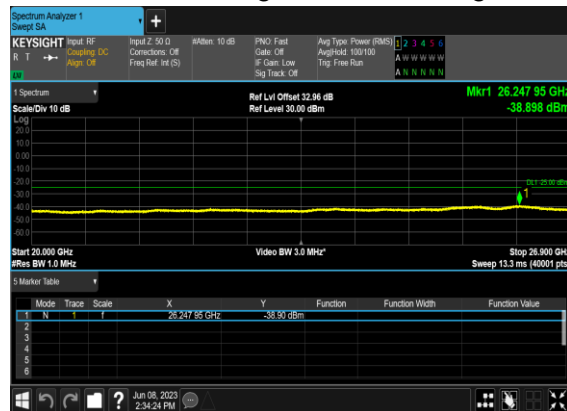

Conducted Band Edge

NR Band	SCS (kHz)	Bandwidth (MHz)	Arfcn	Freq (MHz)	Modulation	RB	Result	Verdict
41	30	20	501204	2506.02	DFT-s-OFDM BPSK	1@0	see graph	PASS
41	30	20	501204	2506.02	DFT-s-OFDM QPSK	1@0	see graph	PASS
41	30	20	501204	2506.02	DFT-s-OFDM BPSK	50@0	see graph	PASS
41	30	20	501204	2506.02	DFT-s-OFDM QPSK	50@0	see graph	PASS
41	30	20	535998	2679.99	DFT-s-OFDM BPSK	1@50	see graph	PASS
41	30	20	535998	2679.99	DFT-s-OFDM QPSK	1@50	see graph	PASS
41	30	20	535998	2679.99	DFT-s-OFDM BPSK	50@0	see graph	PASS
41	30	20	535998	2679.99	DFT-s-OFDM QPSK	50@0	see graph	PASS
41	30	60	505200	2526.0	DFT-s-OFDM BPSK	1@0	see graph	PASS
41	30	60	505200	2526.0	DFT-s-OFDM QPSK	1@0	see graph	PASS
41	30	60	505200	2526.0	DFT-s-OFDM BPSK	162@0	see graph	PASS
41	30	60	505200	2526.0	DFT-s-OFDM QPSK	162@0	see graph	PASS
41	30	60	531996	2659.98	DFT-s-OFDM BPSK	1@161	see graph	PASS
41	30	60	531996	2659.98	DFT-s-OFDM QPSK	1@161	see graph	PASS
41	30	60	531996	2659.98	DFT-s-OFDM BPSK	162@0	see graph	PASS
41	30	60	531996	2659.98	DFT-s-OFDM QPSK	162@0	see graph	PASS
41	30	100	509202	2546.01	DFT-s-OFDM BPSK	1@0	see graph	PASS
41	30	100	509202	2546.01	DFT-s-OFDM QPSK	1@0	see graph	PASS
41	30	100	509202	2546.01	DFT-s-OFDM BPSK	270@0	see graph	PASS
41	30	100	509202	2546.01	DFT-s-OFDM QPSK	270@0	see graph	PASS
41	30	100	528000	2640.0	DFT-s-OFDM BPSK	1@272	see graph	PASS
41	30	100	528000	2640.0	DFT-s-OFDM QPSK	1@272	see graph	PASS
41	30	100	528000	2640.0	DFT-s-OFDM BPSK	270@0	see graph	PASS
41	30	100	528000	2640.0	DFT-s-OFDM QPSK	270@0	see graph	PASS

N41(20M)_DFT-s- OFDM_BPSK_Edge_1RB_Left_Low_CH

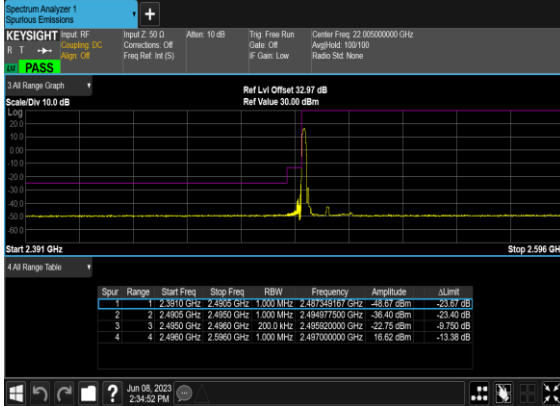

N41(20M)_DFT-s- OFDM_QPSK_Edge_1RB_Left_Low_CH

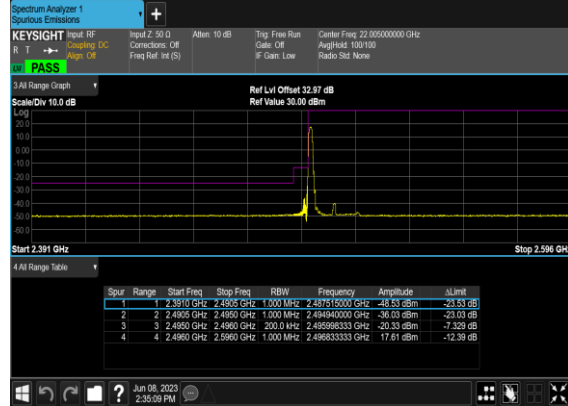

N41(20M)_DFT-s- OFDM_BPSK_Outer_Full_Low_CH

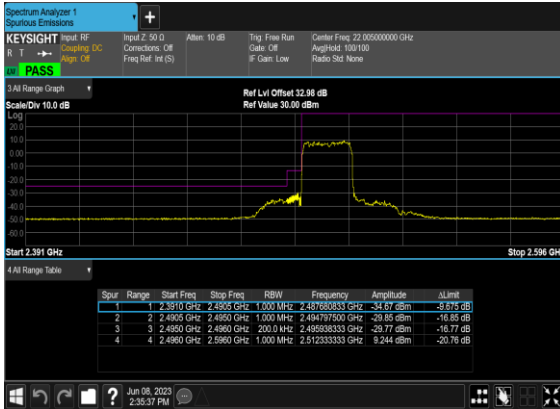

N41(20M)_DFT-s- OFDM_QPSK_Outer_Full_Low_CH

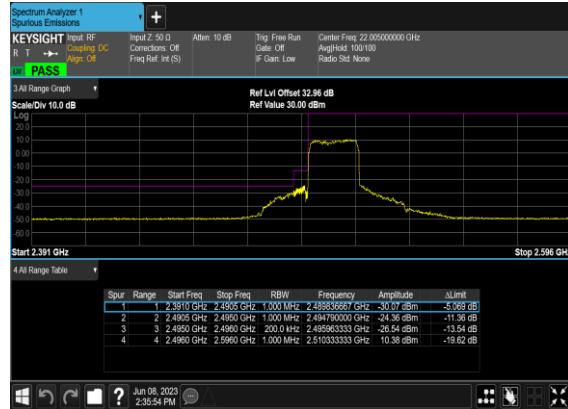

N41(20M)_DFT-s- OFDM_BPSK_Edge_1RB_Right_High_CH

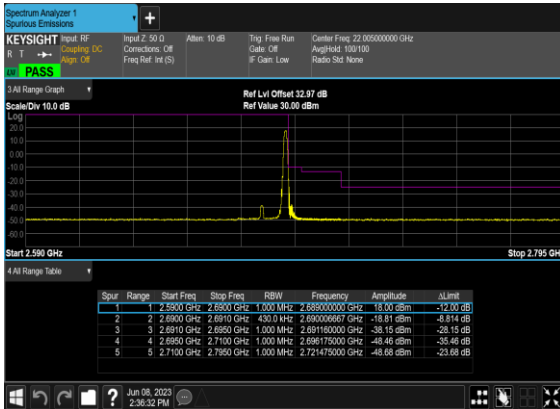

N41(20M)_DFT-s- OFDM_QPSK_Edge_1RB_Right_High_CH

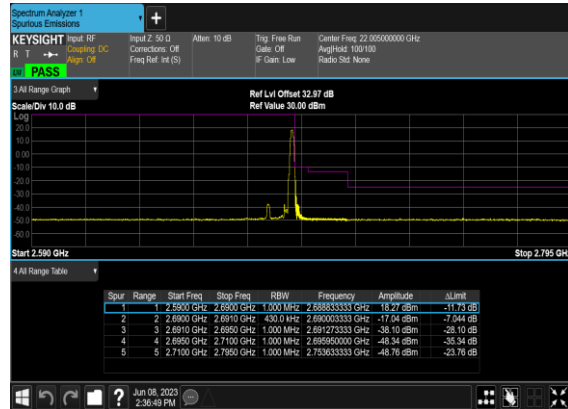

N41(20M)_DFT-s-OFDM_BPSK_Outer_Full_High_CH

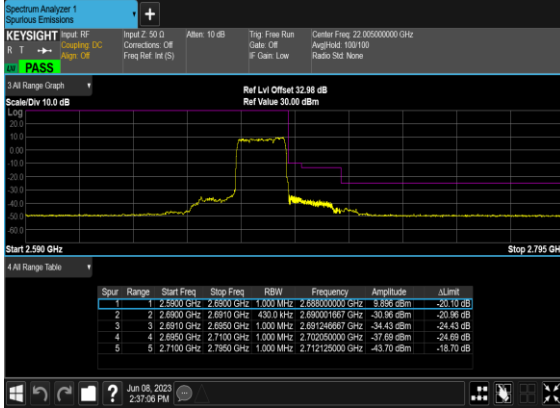

N41(20M)_DFT-s-OFDM_QPSK_Outer_Full_High_CH

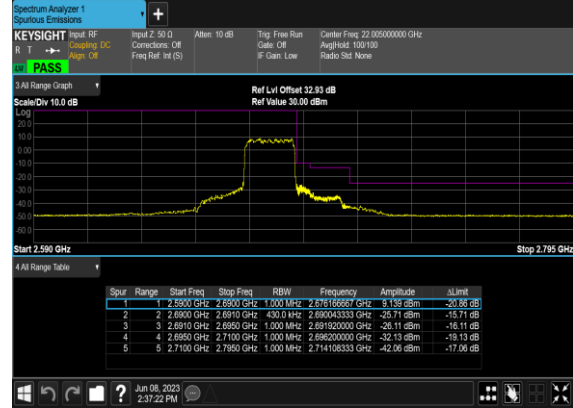

N41(60M)_DFT-s-OFDM_BPSK_Edge_1RB_Left_Low_CH

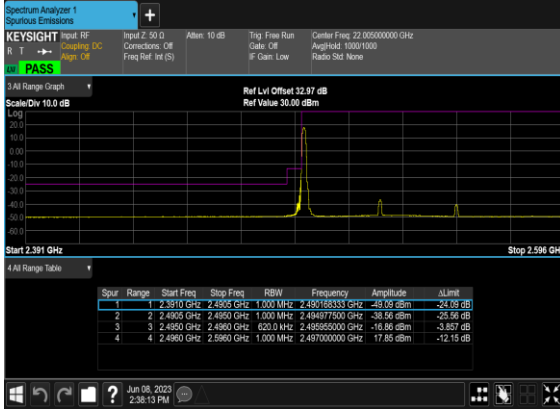

N41(60M)_DFT-s-OFDM_QPSK_Edge_1RB_Left_Low_CH

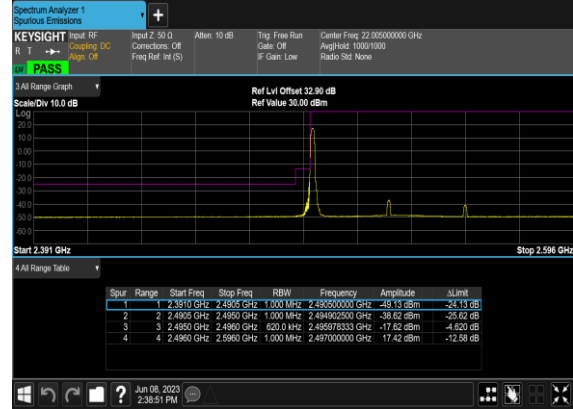

N41(60M)_DFT-s-OFDM_BPSK_Outer_Full_Low_CH

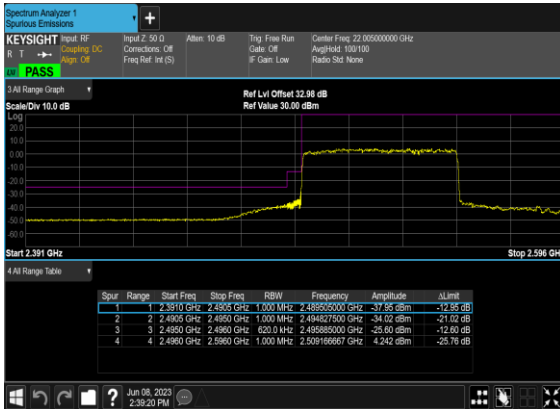

N41(60M)_DFT-s-OFDM_QPSK_Outer_Full_Low_CH

