



FCC RF Test Report

APPLICANT : Motorola Mobility LLC
EQUIPMENT : Mobile Cellular Phone
BRAND NAME : Motorola
MODEL NAME : XT2301-4
FCC ID : IHDT56AH3
STANDARD : 47 CFR Part 2, 22, 24, 27
CLASSIFICATION : PCS Licensed Transmitter Held to Ear (PCE)
TEST DATE(S) : Sep. 07, 2022 ~ Sep. 29, 2022

We, Sporton International Inc. (Kunshan), would like to declare that the tested sample has been evaluated in accordance with the procedures given in ANSI C63.26-2015 and shown compliance with the applicable technical standards.

The test results in this report apply exclusively to the tested model / sample. Without written approval of Sporton International Inc. (Kunshan), the test report shall not be reproduced except in full.

Jason Jia

Approved by: Jason Jia



Sporton International Inc. (Kunshan)

**No. 1098, Pengxi North Road, Kunshan Economic Development Zone Jiangsu Province 215300
People's Republic of China**



TABLE OF CONTENTS

REVISION HISTORY...3
SUMMARY OF TEST RESULT...4
1 GENERAL DESCRIPTION...5
1.1 Applicant...5
1.2 Manufacturer...5
1.3 Product Feature of Equipment Under Test...5
1.4 Product Specification of Equipment Under Test...5
1.5 Modification of EUT...6
1.6 Specification of Accessory...6
1.7 Maximum ERP/EIRP Power and Emission Designator...7
1.8 Testing Location...8
1.9 Test Software...8
1.10 Applicable Standards...8
2 TEST CONFIGURATION OF EQUIPMENT UNDER TEST...9
2.1 Test Mode...9
2.2 Connection Diagram of Test System...10
2.3 Support Unit used in test configuration and system...11
2.4 Measurement Results Explanation Example...11
2.5 Frequency List of Low/Middle/High Channels...12
3 CONDUCTED TEST ITEMS...14
3.1 Measuring Instruments...14
3.2 Test Setup...14
3.3 Test Result of Conducted Test...14
3.4 Conducted Output Power and ERP/EIRP...15
3.5 Peak-to-Average Ratio...16
3.6 Occupied Bandwidth...17
3.7 Conducted Band Edge...18
3.8 Conducted Spurious Emission...20
3.9 Frequency Stability...21
4 RADIATED TEST ITEMS...22
4.1 Measuring Instruments...22
4.2 Test Setup...22
4.3 Test Result of Radiated Test...23
4.4 Radiated Spurious Emission...24
5 LIST OF MEASURING EQUIPMENT...25
6 UNCERTAINTY OF EVALUATION...26
APPENDIX A. TEST RESULTS OF CONDUCTED TEST
APPENDIX B. TEST RESULTS OF RADIATED TEST
APPENDIX C. TEST SETUP PHOTOGRAPHS



REVISION HISTORY

REPORT NO.	VERSION	DESCRIPTION	ISSUED DATE
FG282619I	Rev. 01	Initial issue of report	Oct. 19, 2022



SUMMARY OF TEST RESULT

Report Section	FCC Rule	Description	Limit	Result	Remark
3.4	§2.1046	Conducted Output Power	Reporting Only	PASS	-
	§22.913(a)(5)	Effective Radiated Power (5G NR n5)	ERP < 7 Watt		
	§24.232(c)	Equivalent Isotropic Radiated Power (5G NR n2)	EIRP < 2Watt		
	§27.50(d)(4)	Equivalent Isotropic Radiated Power (5G NR n66)	EIRP < 1Watt		
3.5	§24.232(d)	Peak-to-Average Ratio	<13 dB	PASS	-
3.6	§2.1049	Occupied Bandwidth	Reporting Only	PASS	-
3.7	§2.1051 §22.917(a) §24.238(a) §27.53(h)	Conducted Band Edge Measurement (5G NR n5) (5G NR n2) (5G NR n66)	< 43+10log10(P[Watts])	PASS	-
3.8	§2.1051 §22.917(a) §24.238(a) §27.53(h)	Conducted Spurious Emission (5G NR n5) (5G NR n2) (5G NR n66)	< 43+10log10(P[Watts])	PASS	-
3.9	§2.1055	Frequency Stability Temperature & Voltage	< 2.5 ppm for Part 22	PASS	-
	§22.355		Within Authorized Band		
	§24.235 §27.54				
4.4	§2.1053 §22.917(a) §24.238(a) §27.53(h)	Radiated Spurious Emission (5G NR n5) (5G NR n2) (5G NR n66)	< 43+10log ₁₀ (P[Watts])	PASS	Under limit 36.18 dB at 7485.000 MHz

Declaration of Conformity:

The test results with all measurement uncertainty excluded are presented in accordance with the regulation limits or requirements declared by manufacturers.

Comments and Explanations:

The declared of product specification for EUT presented in the report are provided by the manufacturer, and the manufacturer takes all the responsibilities for the accuracy of product specification.



1 General Description

1.1 Applicant

Motorola Mobility LLC
222 W, Merchandise Mart Plaza, Chicago IL 60654 USA

1.2 Manufacturer

Motorola Mobility LLC
222 W, Merchandise Mart Plaza, Chicago IL 60654 USA

1.3 Product Feature of Equipment Under Test

Product Feature	
Equipment	Mobile Cellular Phone
Brand Name	Motorola
Model Name	XT2301-4
FCC ID	IHDT56AH3
IMEI Code	Conducted: 354336350017059/354336350017067 Radiation: 354336350016416
HW Version	DVT2
SW Version	TTR33.76
EUT Stage	Identical Prototype

1.4 Product Specification of Equipment Under Test

Standards-related Product Specification	
Tx Frequency	5G NR n2 : 1850 MHz ~ 1910 MHz 5G NR n5 : 824 MHz ~ 849 MHz 5G NR n66 : 1710 MHz ~ 1780 MHz
Rx Frequency	5G NR n2 : 1930 MHz ~ 1990 MHz 5G NR n5 : 869 MHz ~ 894 MHz 5G NR n66 : 2110 MHz~ 2200 MHz
Bandwidth	n2, n5: 5MHz / 10MHz / 15MHz / 20MHz n66: 5MHz / 10MHz / 15MHz / 20MHz / 25MHz / 30MHz / 40MHz
SCS	15kHz
Antenna Gain	<Ant. 0>: n5: -5 dBi <Ant. 1>: n2: -0.58 dBi n5: -5.76 dBi n66: -1.91 dBi <Ant. 2>: n2: -3.1 dBi n66: -3.5 dBi
Type of Modulation	CP-OFDM: QPSK / 16QAM / 64QAM / 256QAM DFT-s-OFDM: PI/2 BPSK / QPSK / 16QAM / 64QAM / 256QAM



Remark:

1. The maximum ERP/EIRP is calculated from max output power and max antenna gain, only the maximum ERP/EIRP are shown in the report, 5G NR n5 for Ant. 0 and n2/n66 for Ant.1.
2. For NSA mode of all EN-DC combination, we only show the combination of the maximum power among all NSA combinations in the report.
3. The EN-DC mode combination could be referred to the product spec.

1.5 Modification of EUT

No modifications are made to the EUT during all test items.

1.6 Specification of Accessory

Specification of Accessory				
AC Adapter 1 (US)	Brand Name	Motorola(Chenyang)	Model Name	MC-1251
AC Adapter 1 (EU)	Brand Name	Motorola(Chenyang)	Model Name	MC-1252
AC Adapter 1 (UK)	Brand Name	Motorola(Chenyang)	Model Name	MC-1253
AC Adapter 1 (AU)	Brand Name	Motorola(Chenyang)	Model Name	MC-1255
AC Adapter 1 (AR)	Brand Name	Motorola(Chenyang)	Model Name	MC-1256
AC Adapter 1 (BR)	Brand Name	Motorola(Chenyang)	Model Name	MC-1257
AC Adapter 2 (US)	Brand Name	Motorola(AOHAI)	Model Name	MC-1251
AC Adapter 2 (EU)	Brand Name	Motorola(AOHAI)	Model Name	MC-1252
AC Adapter 2 (UK)	Brand Name	Motorola(AOHAI)	Model Name	MC-1253
AC Adapter 2 (IN)	Brand Name	Motorola(AOHAI)	Model Name	MC-1254
AC Adapter 2 (AU)	Brand Name	Motorola(AOHAI)	Model Name	MC-1255
AC Adapter 2 (AR)	Brand Name	Motorola(AOHAI)	Model Name	MC-1256
AC Adapter 2 (BR)	Brand Name	Motorola(AOHAI)	Model Name	MC-1257
AC Adapter 2 (CHILE)	Brand Name	Motorola(AOHAI)	Model Name	MC-1259
Battery	Brand Name	Motorola(ATL)	Model Name	PF46
Earphone	Brand Name	Motorola(Lyand)	Model Name	MI181C(SH38D62338)
USB Cable	Brand Name	Motorola (Saibao)	Model Name	SC18D24968
C to HDMI HDMI/USBC Cable 1	Brand Name	Motorola (Linxee)	Model Name	SC18D02146
C to HDMI HDMI/USBC Cable 2	Brand Name	Motorola (Linxee)	Model Name	SC18D38847



1.7 Maximum ERP/EIRP Power and Emission Designator

5G NR n2		PI/2 BPSK / QPSK		16QAM / 64QAM / 256QAM	
BW (MHz)	Frequency Range (MHz)	Maximum EIRP(W)	Emission Designator (99%OBW)	Maximum EIRP(W)	Emission Designator (99%OBW)
5	1852.5 ~ 1907.5	0.1879	4M48G7D	0.1538	4M54W7D
10	1855.0 ~ 1905.0	0.1828	9M45G7D	0.1552	9M43W7D
15	1857.5 ~ 1902.5	0.1871	14M2G7D	0.1560	14M2W7D
20	1860.0 ~ 1900.0	0.1928	18M9G7D	0.1578	18M9W7D

5G NR n5		PI/2 BPSK / QPSK		16QAM / 64QAM / 256QAM	
BW (MHz)	Frequency Range (MHz)	Maximum ERP(W)	Emission Designator (99%OBW)	Maximum ERP(W)	Emission Designator (99%OBW)
5	826.5 ~ 846.5	0.0362	4M47G7D	0.0291	4M51W7D
10	829.0 ~ 844.0	0.0363	9M35G7D	0.0293	9M37W7D
15	831.5 ~ 841.5	0.0366	13M5G7D	0.0299	13M5W7D
20	834.0 ~ 839.0	0.0375	18M9G7D	0.0304	19M0W7D

5G NR n66		PI/2 BPSK / QPSK		16QAM / 64QAM / 256QAM	
BW (MHz)	Frequency Range (MHz)	Maximum EIRP(W)	Emission Designator (99%OBW)	Maximum EIRP(W)	Emission Designator (99%OBW)
5	1712.5 ~ 1777.5	0.1390	4M51G7D	0.1175	4M52W7D
10	1715.0 ~ 1775.0	0.1377	9M35G7D	0.1186	9M43W7D
15	1717.5 ~ 1772.5	0.1413	14M2G7D	0.1180	14M2W7D
20	1720.0 ~ 1770.0	0.1426	18M9G7D	0.1180	19M1W7D
25	1722.5 ~ 1767.5	0.1334	23M7G7D	0.1180	23M8W7D
30	1725.0 ~ 1765.0	0.1426	28M5G7D	0.1197	28M7W7D
40	1730.0 ~ 1760.0	0.1466	38M7G7D	0.1211	38M8W7D

Note: All modulations have been tested, only the worst test results of PSK & QAM are shown in the report.



1.8 Testing Location

Sporton International Inc. (Kunshan) is accredited to ISO/IEC 17025:2017 by American Association for Laboratory Accreditation with Certificate Number 5145.02.

Test Firm	Sporton International Inc. (Kunshan)		
Test Site Location	No. 1098, Pengxi North Road, Kunshan Economic Development Zone Jiangsu Province 215300 People's Republic of China TEL : +86-512-57900158 FAX : +86-512-57900958		
Test Site No.	Sporton Site No.	FCC Designation No.	FCC Test Firm Registration No.
	03CH04-KS TH01-KS	CN1257	314309

1.9 Test Software

Item	Site	Manufacturer	Name	Version
1.	03CH04-KS	AUDIX	E3	6.2009-8-24al

1.10 Applicable Standards

According to the specifications of the manufacturer, the EUT must comply with the requirements of the following standards:

- ♦ 47 CFR Part 2, 22, 24, 27
- ♦ ANSI C63.26-2015
- ♦ FCC KDB 971168 D01 Power Meas License Digital Systems v03r01
- ♦ FCC KDB 412172 D01 Determining ERP and EIRP v01r01

Remark:

All test items were verified and recorded according to the standards and without any deviation during the test.



2 Test Configuration of Equipment Under Test

2.1 Test Mode

Antenna port conducted and radiated test items are performed according to KDB 971168 D01 Power Meas License Digital Systems v03r01 with maximum output power.

For radiated measurement, pre-scanned in three orthogonal panels, X, Y, Z. The worst cases (Z plane) were recorded in this report.

The device is investigated from 30MHz to 10 times of fundamental signal for radiated spurious emission test under different RB size/offset and modulations in exploratory test. Subsequently, only the worst case emissions are reported.

Orthogonal Planes of EUT	X Plane	Y Plane	Z Plane
			

Test Items	5G NR	Bandwidth (MHz)													Modulation				RB #			Test Channel					
		5	10	15	20	25	30	40	50	60	70	80	90	100	PI/2 BPSK	QPSK	16QAM	64QAM	256QAM	1	Half	Full	L	M	H		
Max. Output Power	n2	v	v	v	v	-	-	-	-	-	-	-	-	-	v	v	v	v	v	v	v	v	v	v	v	v	
	n5	v	v	v	v	-	-	-	-	-	-	-	-	-	v	v	v	v	v	v	v	v	v	v	v	v	v
	n66	v	v	v	v	v	v	v	-	-	-	-	-	-	v	v	v	v	v	v	v	v	v	v	v	v	v
Peak-to-Average Ratio	n2				v	-	-	-	-	-	-	-	-	-	v	v						v		v			
	n5				v	-	-	-	-	-	-	-	-	-	v	v						v		v			
	n66							v	-	-	-	-	-	-	v	v						v		v			
26dB and 99% Bandwidth	n2	v	v	v	v	-	-	-	-	-	-	-	-	-	v	v	v	v	v			v		v			
	n5	v	v	v	v	-	-	-	-	-	-	-	-	-	v	v	v	v	v			v		v			
	n66	v	v	v	v	v	v	v	-	-	-	-	-	-	v	v	v	v	v			v		v			
Conducted Band Edge	n2	v	v	v	v	-	-	-	-	-	-	-	-	-	v	v					v		v		v		
	n5	v	v	v	v	-	-	-	-	-	-	-	-	-	v	v					v		v		v		
	n66	v	v	v	v	v	v	v	-	-	-	-	-	-	v	v					v		v		v		
Conducted Spurious Emission	n2	v	v	v	v	-	-	-	-	-	-	-	-	-	v	v					v		v		v		
	n5	v	v	v	v	-	-	-	-	-	-	-	-	-	v	v					v		v		v		
	n66	v	v	v	v	v	v	v	-	-	-	-	-	-	v	v					v		v		v		
Frequency Stability	n2				v	-	-	-	-	-	-	-	-	-		v						v		v			
	n5				v	-	-	-	-	-	-	-	-	-		v						v		v			



Test Items	5G NR	Bandwidth (MHz)												Modulation				RB #			Test Channel				
		5	10	15	20	25	30	40	50	60	70	80	90	100	PI/2 BPSK	QPSK	16QAM	64QAM	256QAM	1	Half	Full	L	M	H
	n66				v				-	-	-	-	-	-		v						v		v	
E.R.P / E.I.R.P	n2	v	v	v	v	-	-	-	-	-	-	-	-	-	v	v	v	v	v	v	v	v	v	v	v
	n5	v	v	v	v	-	-	-	-	-	-	-	-	-	v	v	v	v	v	v	v	v	v	v	v
	n66	v	v	v	v	v	v	v	v	-	-	-	-	-	v	v	v	v	v	v	v	v	v	v	v
Radiated Spurious Emission	n2	Worst Case																					v		
	n5	Worst Case																					v		
	N66	Worst Case																					v		
Note	<ol style="list-style-type: none"> The mark "v" means that this configuration is chosen for testing The mark "-" means that this bandwidth is not supported. The device is investigated from 30MHz to 10 times of fundamental signal for radiated spurious emission test under different RB size/offset and modulations in exploratory test. Subsequently, only the worst case emissions are reported. Frequency Stability : Normal Voltage = 3.87V ; Low Voltage =3.40V. ; High Voltage =4.48V 																								

2.2 Connection Diagram of Test System

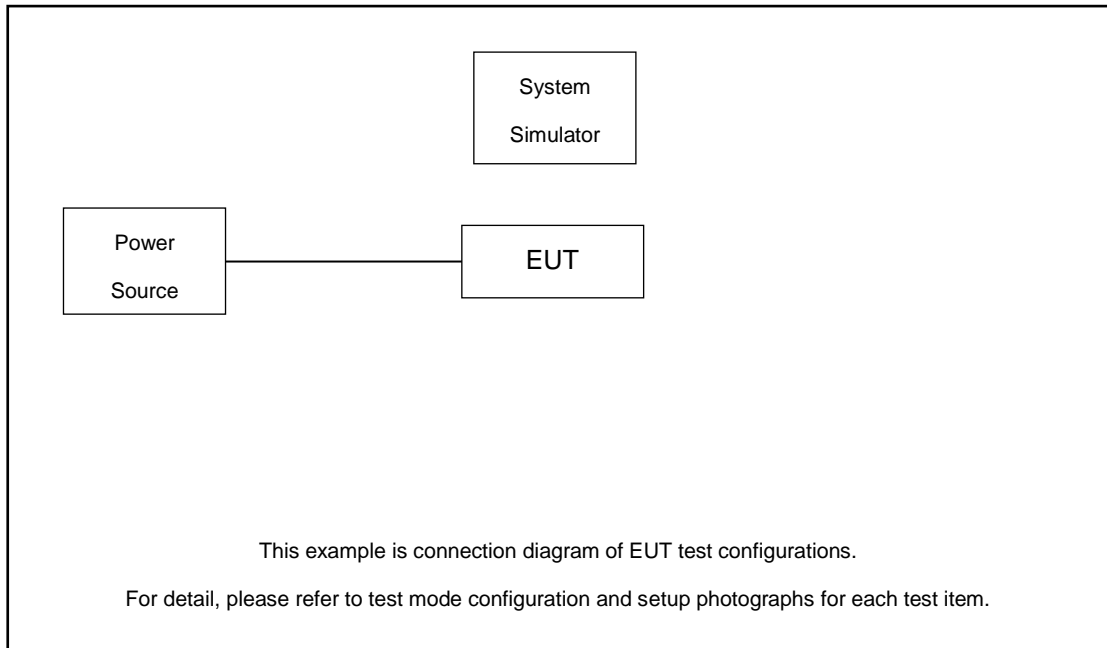

The EUT has been configuration operated in a manner tended to maximize its emission characteristics in a typical application.



2.3 Support Unit used in test configuration and system

Item	Equipment	Trade Name	Model No.	FCC ID	Data Cable	Power Cord
1.	DC Power Supply	GW	GPS-3030D	N/A	N/A	Unshielded, 1.8 m
2.	LTE Base Station	Anritsu	MT8821C	N/A	N/A	Unshielded, 1.8 m
3.	NR Base Station	Anritsu	MT8000A	N/A	N/A	Unshielded, 1.8 m

2.4 Measurement Results Explanation Example

For all conducted test items:

The offset level is set in the spectrum analyzer to compensate the RF cable loss between EUT conducted output port and spectrum analyzer. With the offset compensation, the spectrum analyzer reading level is exactly the EUT RF output level.

The spectrum analyzer offset is derived from RF cable loss.

$$\text{Offset} = \text{RF cable loss.}$$

Following shows an offset computation example with cable loss 5.6 dB.

Example :

$$\begin{aligned} \text{Offset(dB)} &= \text{RF cable loss(dB)}. \\ &= 5.6 \text{ (dB)} \end{aligned}$$



2.5 Frequency List of Low/Middle/High Channels

5G NR n2 Channel and Frequency List				
BW [MHz]	Channel/Frequency(MHz)	Lowest	Middle	Highest
20	Channel	372000	376000	380000
	Frequency	1860	1880	1900
15	Channel	371500	376000	380500
	Frequency	1857.5	1880	1902.5
10	Channel	371000	376000	381000
	Frequency	1855	1880	1905
5	Channel	370500	376000	381500
	Frequency	1852.5	1880	1907.5

5G NR n5 Channel and Frequency List				
BW [MHz]	Channel/Frequency(MHz)	Lowest	Middle	Highest
20	Channel	166800	167300	167800
	Frequency	834	836.5	839
15	Channel	166300	167300	168300
	Frequency	831.5	836.5	841.5
10	Channel	165800	167300	168800
	Frequency	829	836.5	844
5	Channel	165300	167300	169300
	Frequency	826.5	836.5	846.5



5G NR n66 Channel and Frequency List				
BW [MHz]	Channel/Frequency(MHz)	Lowest	Middle	Highest
40	Channel	346000	349000	352000
	Frequency	1730	1745	1760
30	Channel	345000	349000	353000
	Frequency	1725	1745	1765
25	Channel	344500	349000	353500
	Frequency	1722.5	1745	1767.5
20	Channel	344000	349000	354000
	Frequency	1720	1745	1770
15	Channel	343500	349000	354500
	Frequency	1717.5	1745	1772.5
10	Channel	343000	349000	355000
	Frequency	1715	1745	1775
5	Channel	342500	349000	355500
	Frequency	1712.5	1745	1777.5

3 Conducted Test Items

3.1 Measuring Instruments

See list of measuring instruments of this test report.

3.2 Test Setup

3.2.1 Conducted Output Power

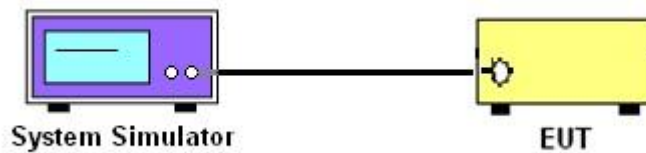

3.2.2 Peak-to-Average Ratio, Occupied Bandwidth ,Conducted Band-Edge and Conducted Spurious Emission

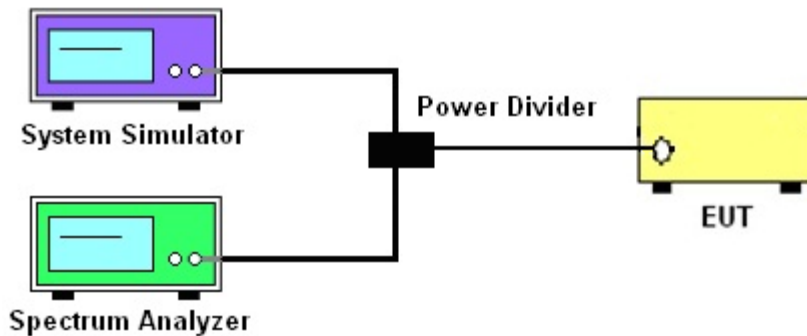

3.2.3 Frequency Stability

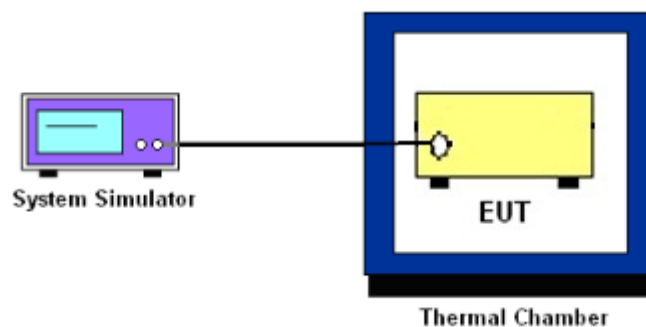

3.3 Test Result of Conducted Test

Please refer to Appendix A.



3.4 Conducted Output Power and ERP/EIRP

3.4.1 Description of the Conducted Output Power Measurement and ERP/EIRP Measurement

A system simulator was used to establish communication with the EUT. Its parameters were set to force the EUT transmitting at maximum output power. The measured power in the radio frequency on the transmitter output terminals shall be reported.

The ERP of mobile transmitters must not exceed 7 Watts for 5G NR n5.

The EIRP of mobile transmitters must not exceed 2 Watts for 5G NR n2.

The EIRP of mobile transmitters must not exceed 1 Watts for 5G NR n66.

According to KDB 412172 D01 Power Approach,

$EIRP = P_T + G_T - L_C$, $ERP = EIRP - 2.15$, where

P_T = transmitter output power in dBm

G_T = gain of the transmitting antenna in dBi

L_C = signal attenuation in the connecting cable between the transmitter and antenna in dB

3.4.2 Test Procedures

1. The testing follows ANSI C63.26 Section 5.2
2. The transmitter output port was connected to the system simulator.
3. Set EUT at maximum power through the system simulator.
4. Select lowest, middle, and highest channels for each band and different modulation.
5. Measure and record the power level from the system simulator.



3.5 Peak-to-Average Ratio

3.5.1 Description of the PAR Measurement

Power Complementary Cumulative Distribution Function (CCDF) curves provide a means for characterizing the power peaks of a digitally modulated signal on a statistical basis. A CCDF curve depicts the probability of the peak signal amplitude exceeding the average power level. Most contemporary measurement instrumentation include the capability to produce CCDF curves for an input signal provided that the instrument's resolution bandwidth can be set wide enough to accommodate the entire input signal bandwidth. In measuring transmissions in this band using an average power technique, the peak-to-average ratio (PAR) of the transmission may not exceed 13 dB.

3.5.2 Test Procedures

1. The testing follows ANSI C63.26 Section 5.2.3.4 (CCDF).
2. The EUT was connected to spectrum and system simulator via a power divider.
3. Set the CCDF (Complementary Cumulative Distribution Function) option in spectrum analyzer.
4. The highest RF powers were measured and recorded the maximum PAPR level associated with a probability of 0.1 %.
5. Record the deviation as Peak to Average Ratio.



3.6 Occupied Bandwidth

3.6.1 Description of Occupied Bandwidth Measurement

The occupied bandwidth is the width of a frequency band such that, below the lower and above the upper frequency limits, the mean powers emitted are each equal to a specified percentage 0.5% of the total mean transmitted power.

The 26 dB emission bandwidth is defined as the frequency range between two points, one above and one below the carrier frequency, at which the spectral density of the emission is attenuated 26 dB below the maximum in-band spectral density of the modulated signal. Spectral density (power per unit bandwidth) is to be measured with a detector of resolution bandwidth equal to approximately 1.0% of the emission bandwidth.

3.6.2 Test Procedures

1. The testing follows ANSI C63.26 Section 5.4
2. The EUT was connected to spectrum analyzer and system simulator via a power divider.
3. The spectrum analyzer center frequency is set to the nominal EUT channel center frequency. The span range for the spectrum analyzer shall be between two and five times the anticipated OBW.
4. The nominal resolution bandwidth (RBW) shall be in the range of 1 to 5 % of the anticipated OBW, and the VBW shall be at least 3 times the RBW.
5. Set the detection mode to peak, and the trace mode to max hold.
6. Determine the reference value: Set the EUT to transmit a modulated signal. Allow the trace to stabilize. Set the spectrum analyzer marker to the highest level of the displayed trace.
(this is the reference value)
7. Determine the “-26 dB down amplitude” as equal to (Reference Value – X).
8. Place two markers, one at the lowest and the other at the highest frequency of the envelope of the spectral display such that each marker is at or slightly below the “-X dB down amplitude” determined in step 6. If a marker is below this “-X dB down amplitude” value it shall be placed as close as possible to this value. The OBW is the positive frequency difference between the two markers.
9. Use the 99 % power bandwidth function of the spectrum analyzer and report the measured bandwidth.



3.7 Conducted Band Edge

3.7.1 Description of Conducted Band Edge Measurement

22.917(a)

For operations in the 824 – 849 MHz band, the FCC limit is $43 + 10\log_{10}(P[\text{Watts}])$ dB below the transmitter power $P(\text{Watts})$ in a 100kHz bandwidth. However, in the 1MHz bands immediately outside and adjacent to the licensee's frequency block, a resolution bandwidth of at least one percent of the emission bandwidth of the fundamental emission of the transmitter may be employed.

24.238 (a)

For operations in the 1850-1910 and 1930-1990 MHz band, the FCC limit is $43 + 10\log_{10}(P[\text{Watts}])$ dB below the transmitter power $P(\text{Watts})$ in a 1MHz bandwidth. However, in the 1 MHz bands immediately outside and adjacent to the frequency block a resolution bandwidth of at least one percent of the emission bandwidth of the fundamental emission of the transmitter may be employed.

27.53 (h)

For operations in the 1710 – 1755 MHz band, the FCC limit is $43 + 10\log_{10}(P[\text{Watts}])$ dB below the transmitter power $P(\text{Watts})$ in a 1 MHz bandwidth. However, in the 1MHz bands immediately outside and adjacent to the licensee's frequency block, a resolution bandwidth of at least one percent of the emission bandwidth of the fundamental emission of the transmitter may be employed.



3.7.2 Test Procedures

1. The testing follows ANSI C63.26 section 5.7
2. The EUT was connected to spectrum analyzer and system simulator via a power divider.
3. The band edges of low and high channels for the highest RF powers were measured.
4. Set RBW \geq 1% EBW in the 1MHz band immediately outside and adjacent to the band edge.
5. Beyond the 1 MHz band from the band edge, RBW=1MHz was used or a narrower RBW was used (generally limited to no less than 1% of the OBW) and the measured power was integrated over the full required measurement bandwidth.
6. Set spectrum analyzer with RMS detector.
7. The RF fundamental frequency should be excluded against the limit line in the operating frequency band.
8. Checked that all the results comply with the emission limit line.

Example:

The limit line is derived from $43 + 10\log(P)$ dB below the transmitter power P(Watts)

$$= P(W) - [43 + 10\log(P)] \text{ (dB)}$$

$$= [30 + 10\log(P)] \text{ (dBm)} - [43 + 10\log(P)] \text{ (dB)} = -13\text{dBm}.$$

9. When using the integration method, the starting frequency of the integration shall be centered at one-half of the RBW away from the band edge.



3.8 Conducted Spurious Emission

3.8.1 Description of Conducted Spurious Emission Measurement

The power of any emission outside of the authorized operating frequency ranges must be lower than the transmitter power (P) by a factor of at least $43 + 10 \log (P)$ dB.

It is measured by means of a calibrated spectrum analyzer and scanned from 30 MHz up to a frequency including its 10th harmonic.

3.8.2 Test Procedures

1. The testing follows ANSI C63.26 section 5.7
2. The EUT was connected to spectrum analyzer and system simulator via a power divider.
3. The RF output of EUT was connected to the spectrum analyzer by RF cable and attenuator. The path loss was compensated to the results for each measurement.
4. The middle channel for the highest RF power within the transmitting frequency was measured.
5. The conducted spurious emission for the whole frequency range was taken.
6. Make the measurement with the spectrum analyzer's RBW = 1MHz, VBW = 3MHz.
7. Set spectrum analyzer with RMS detector.
8. Taking the record of maximum spurious emission.
9. The RF fundamental frequency should be excluded against the limit line in the operating frequency band.
10. The limit line is derived from $43 + 10\log(P)$ dB below the transmitter power P(Watts)
= P(W)- [43 + 10log(P)] (dB)
= [30 + 10log(P)] (dBm) - [43 + 10log(P)] (dB)
= -13dBm.



3.9 Frequency Stability

3.9.1 Description of Frequency Stability Measurement

The frequency stability shall be measured by variation of ambient temperature and variation of primary supply voltage to ensure that the fundamental emission stays within the authorized frequency block. The frequency stability of the transmitter shall be maintained within $\pm 0.00025\%$ ($\pm 2.5\text{ppm}$) of the center frequency.

3.9.2 Test Procedures for Temperature Variation

1. The testing follows ANSI C63.26 section 5.6.4
2. The EUT was set up in the thermal chamber and connected with the system simulator.
3. With power OFF, the temperature was decreased to -30°C and the EUT was stabilized before testing. Power was applied and the maximum change in frequency was recorded within one minute.
4. With power OFF, the temperature was raised in 10°C step up to 50°C . The EUT was stabilized at each step for at least half an hour. Power was applied and the maximum frequency change was recorded within one minute.

3.9.3 Test Procedures for Voltage Variation

1. The testing follows ANSI C63.26 section 5.6.5
2. The EUT was placed in a temperature chamber at $20\pm 5^{\circ}\text{C}$ and connected with the system simulator.
3. The power supply voltage to the EUT was varied from 85% to 115% of the nominal value for other than hand carried battery equipment.
4. For hand carried, battery powered equipment, reduce the primary ac or dc supply voltage to the battery operating end point, which shall be specified by the manufacturer.
5. The variation in frequency was measured for the worst case.

4 Radiated Test Items

4.1 Measuring Instruments

See list of measuring instruments of this test report.

4.2 Test Setup

4.2.1 For radiated test below 30MHz

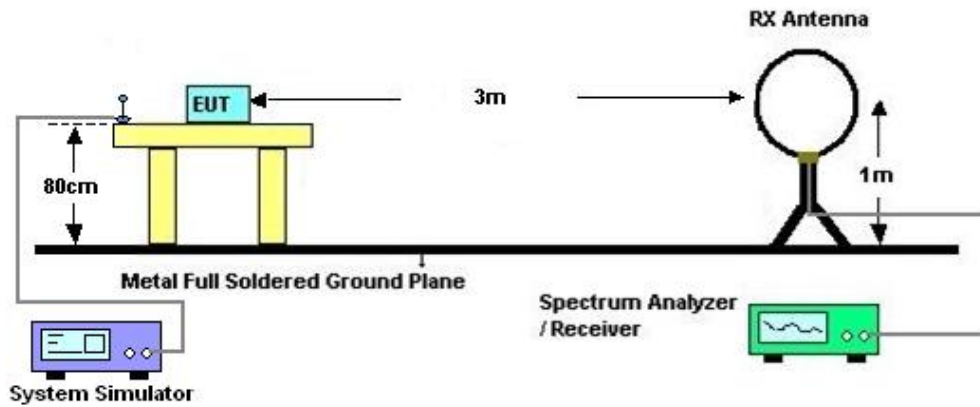

4.2.2 For radiated test from 30MHz to 1GHz

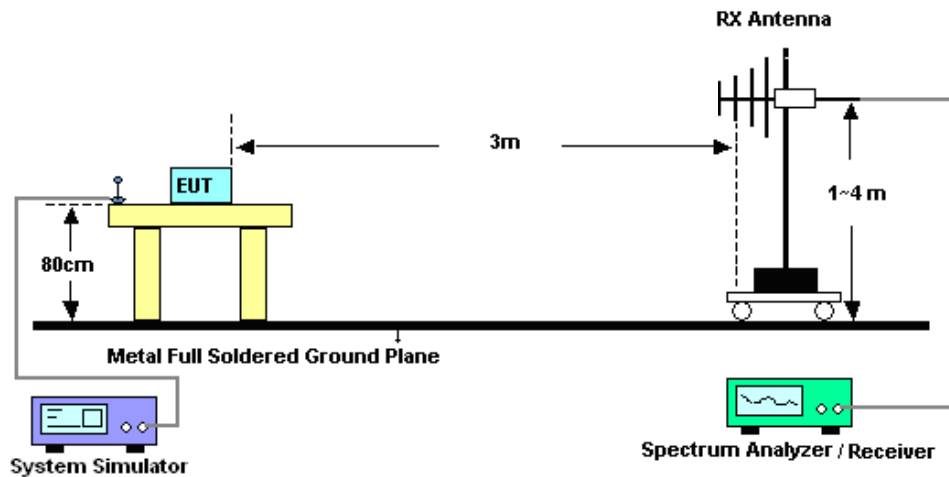

4.2.3 For radiated test above 1GHz

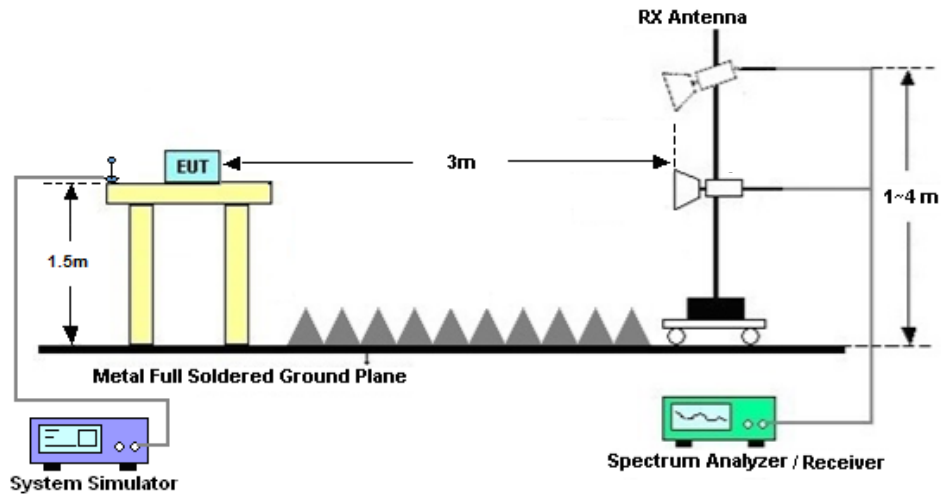

4.3 Test Result of Radiated Test

The low frequency, which started from 9 kHz to 30MHz, was pre-scanned and the result which was 20dB lower than the limit line was not reported.

Please refer to Appendix B.



4.4 Radiated Spurious Emission

4.4.1 Description of Radiated Spurious Emission

The radiated spurious emission was measured by substitution method according to ANSI C63.26. The power of any emission outside of the authorized operating frequency ranges must be attenuated below the transmitter power (P) by a factor of at least $43 + 10 \log (P)$ dB.

The spectrum is scanned from 30 MHz up to a frequency including its 10th harmonic.

4.4.2 Test Procedures

1. The testing follows ANSI C63.26 Section 5.5
2. The EUT was placed on a turntable with 0.8 meter height for frequency below 1GHz and 1.5 meter height for frequency above 1GHz respectively above ground.
3. The EUT was set 3 meters from the receiving antenna mounted on the antenna tower.
4. The table was rotated 360 degrees to determine the position of the highest spurious emission.
5. The height of the receiving antenna is varied between 1m to 4m to search the maximum spurious emission for both horizontal and vertical polarizations.
6. During the measurement, the system simulator parameters were set to force the EUT transmitting at maximum output power.
7. Make the measurement with the spectrum analyzer's RBW = 1MHz, VBW = 3MHz, taking the record of maximum spurious emission.
8. A horn antenna was substituted in place of the EUT and was driven by a signal generator.
9. Tune the output power of signal generator to the same emission level with EUT maximum spurious emission.
10. $EIRP \text{ (dBm)} = S.G. \text{ Power} - Tx \text{ Cable Loss} + Tx \text{ Antenna Gain}$
11. $ERP \text{ (dBm)} = EIRP - 2.15$
12. The RF fundamental frequency should be excluded against the limit line in the operating frequency band.

The limit line is derived from $43 + 10\log(P)$ dB below the transmitter power P(Watts)
 $= P(W) - [43 + 10\log(P)] \text{ (dB)}$
 $= [30 + 10\log(P)] \text{ (dBm)} - [43 + 10\log(P)] \text{ (dB)}$
 $= -13\text{dBm}.$



5 List of Measuring Equipment

Instrument	Manufacturer	Model No.	Serial No.	Characteristics	Calibration Date	Test Date	Due Date	Remark
Spectrum Analyzer	R&S	FSV40	101040	10Hz~40GHz	Oct. 14, 2021	Sep. 07, 2022~ Sep. 14, 2022	Oct. 13, 2022	Conducted (TH01-KS)
Power divider	STI	STI08-0055	-	0.5~40GHz	Aug. 26, 2022	Sep. 07, 2022~ Sep. 14, 2022	Aug. 25, 2023	Conducted (TH01-KS)
Temperature & humidity chamber	Hongzhan	LP-150U	H2014011440	-40~+150°C 20%~95%RH	Jul. 15, 2022	Sep. 07, 2022~ Sep. 14, 2022	Jul. 14, 2023	Conducted (TH01-KS)
EXA Spectrum Analyzer	Keysight	N9010B	MY57541079	10Hz-44G,MAX 30dB	Oct. 14, 2021	Sep. 29, 2022	Oct. 13, 2022	Radiation (03CH04-KS)
Loop Antenna	R&S	HFH2-Z2	100321	9kHz~30MHz	Oct. 30, 2021	Sep. 29, 2022	Oct. 29, 2022	Radiation (03CH04-KS)
Bilog Antenna	TeseQ	CBL6111D	49922	30MHz-1GHz	May 24, 2022	Sep. 29, 2022	May 23, 2023	Radiation (03CH04-KS)
Horn Antenna	Schwarzbeck	BBHA9120D	1284	1GHz~18GHz	Jan. 05, 2022	Sep. 29, 2022	Jan. 04, 2023	Radiation (03CH04-KS)
SHF-EHF Horn	Com-power	AH-840	101070	18GHz~40GHz	Jan. 05, 2022	Sep. 29, 2022	Jan. 04, 2023	Radiation (03CH04-KS)
Amplifier	SONOMA	310N	187289	9KHz-1GHz	Jan. 05, 2022	Sep. 29, 2022	Jan. 04, 2023	Radiation (03CH04-KS)
Amplifier	MITEQ	EM18G40G GA	060728	18~40GHz	Jan. 05, 2022	Sep. 29, 2022	Jan. 04, 2023	Radiation (03CH04-KS)
high gain Amplifier	EM	EM01G18G A	060839	1Ghz-18Ghz	Oct. 14, 2021	Sep. 29, 2022	Oct. 13, 2022	Radiation (03CH04-KS)
Amplifier	Keysight	83017A	MY57280106	500MHz~26.5GHz	Oct. 13, 2021	Sep. 29, 2022	Oct. 12, 2022	Radiation (03CH04-KS)
AC Power Source	Chroma	61601	F104090004	N/A	NCR	Sep. 29, 2022	NCR	Radiation (03CH04-KS)
Turn Table	ChamPro	EM 1000-T	060762-T	0~360 degree	NCR	Sep. 29, 2022	NCR	Radiation (03CH04-KS)
Antenna Mast	ChamPro	EM 1000-A	060762-A	1 m~4 m	NCR	Sep. 29, 2022	NCR	Radiation (03CH04-KS)

NCR: No Calibration Required



6 Uncertainty of Evaluation

The measurement uncertainties shown below were calculated in accordance with the requirements of ANSI 63.26-2015. All the measurement uncertainty value were shown with a coverage K=2 to indicate 95% level of confidence. The measurement data show herein meets or exceeds the CISPR measurement uncertainty values specified in CISPR 16-4-2 and can be compared directly to specified limit to determine compliance.

Uncertainty of Radiated Emission Measurement (30 MHz ~ 1000 MHz)

Measuring Uncertainty for a Level of Confidence of 95% (U = 2Uc(y))	3.3 dB
---	--------

Uncertainty of Radiated Emission Measurement (1 GHz ~ 18 GHz)

Measuring Uncertainty for a Level of Confidence of 95% (U = 2Uc(y))	2.8 dB
---	--------

Uncertainty of Radiated Emission Measurement (18 GHz ~ 40 GHz)

Measuring Uncertainty for a Level of Confidence of 95% (U = 2Uc(y))	2.8 dB
---	--------

----- THE END -----



Appendix A. Test Results of Conducted Test

Conducted Output Power(Average power) and ERP/EIRP

5G NR n2:

BW [MHz]	Modulation	RB Size	RB Offset	Power Low Ch. / Freq.	Power Middle Ch. / Freq.	Power High Ch. / Freq.	Gain	EIRP	EIRP	EIRP
Channel				372000	376000	380000		L	M	H
Frequency (MHz)				1860	1880	1900				
20	PI/2 BPSK	1	1	23.20	23.41	23.12	-0.58	0.1828	0.1919	0.1795
20	QPSK	1	1	23.17	23.30	23.36	-0.58	0.1816	0.1871	0.1897
20	QPSK	1	53	23.22	23.40	23.31	-0.58	0.1837	0.1914	0.1875
20	QPSK	1	104	23.19	23.43	23.25	-0.58	0.1824	0.1928	0.1849
20	QPSK	50	0	22.40	22.38	22.32	-0.58	0.1521	0.1514	0.1493
20	QPSK	50	28	23.30	23.27	23.24	-0.58	0.1871	0.1858	0.1845
20	QPSK	50	56	22.29	22.39	22.30	-0.58	0.1483	0.1517	0.1486
20	QPSK	100	0	22.32	22.40	22.34	-0.58	0.1493	0.1521	0.1500
20	16QAM	1	1	22.40	22.56	22.45	-0.58	0.1521	0.1578	0.1538
20	64QAM	1	1	20.59	20.74	20.71	-0.58	0.1002	0.1038	0.1030
20	256QAM	1	1	18.64	18.82	18.73	-0.58	0.0640	0.0667	0.0653
Channel				371500	376000	380500	Gain	EIRP	EIRP	EIRP
Frequency (MHz)				1857.5	1880	1902.5				
15	PI/2 BPSK	1	1	23.15	23.21	23.30	-0.58	0.1807	0.1832	0.1871
15	QPSK	1	1	23.01	23.11	23.00	-0.58	0.1750	0.1791	0.1746
15	16QAM	1	1	22.36	22.51	22.40	-0.58	0.1507	0.1560	0.1521
Channel				371000	376000	381000	Gain	EIRP	EIRP	EIRP
Frequency (MHz)				1855	1880	1905				
10	PI/2 BPSK	1	1	23.20	23.15	23.14	-0.58	0.1828	0.1807	0.1803
10	QPSK	1	1	23.02	23.07	22.98	-0.58	0.1754	0.1774	0.1738
10	16QAM	1	1	22.32	22.49	22.36	-0.58	0.1493	0.1552	0.1507
Channel				370500	376000	381500	Gain	EIRP	EIRP	EIRP
Frequency (MHz)				1852.5	1880	1907.5				
5	PI/2 BPSK	1	1	23.20	23.32	23.17	-0.58	0.1828	0.1879	0.1816
5	QPSK	1	1	23.04	23.20	22.87	-0.58	0.1762	0.1828	0.1694
5	16QAM	1	1	22.33	22.45	22.35	-0.58	0.1496	0.1538	0.1503



5G NR n5:

BW [MHz]	Modulation	RB Size	RB Offset	Power Low Ch. / Freq.	Power Middle Ch. / Freq.	Power High Ch. / Freq.	Gain	ERP	ERP	ERP
Channel				166800	167300	167800		L	M	H
Frequency (MHz)				834	836.5	839				
20	PI/2 BPSK	1	1	22.51	22.81	22.60	-5.0	0.0344	0.0368	0.0351
20	QPSK	1	1	22.38	22.80	22.87	-5.0	0.0333	0.0367	0.0373
20	QPSK	1	53	22.51	22.86	22.76	-5.0	0.0344	0.0372	0.0364
20	QPSK	1	104	22.35	22.80	22.89	-5.0	0.0331	0.0367	0.0375
20	QPSK	50	0	21.82	21.92	21.85	-5.0	0.0293	0.0300	0.0295
20	QPSK	50	28	22.78	22.80	22.64	-5.0	0.0366	0.0367	0.0354
20	QPSK	50	56	21.74	21.89	21.68	-5.0	0.0288	0.0298	0.0284
20	QPSK	100	0	21.86	21.87	21.85	-5.0	0.0296	0.0296	0.0295
20	16QAM	1	1	21.70	21.98	21.64	-5.0	0.0285	0.0304	0.0281
20	64QAM	1	1	19.92	20.12	19.98	-5.0	0.0189	0.0198	0.0192
20	256QAM	1	1	18.18	18.23	18.35	-5.0	0.0127	0.0128	0.0132
Channel				166300	167300	168300	Gain	ERP	ERP	ERP
Frequency (MHz)				831.5	836.5	841.5				
15	PI/2 BPSK	1	1	22.71	22.79	22.65	-5.0	0.0360	0.0366	0.0355
15	QPSK	1	1	22.56	22.64	22.33	-5.0	0.0348	0.0354	0.0330
15	16QAM	1	1	21.66	21.90	21.58	-5.0	0.0282	0.0299	0.0277
Channel				165800	167300	168800	Gain	ERP	ERP	ERP
Frequency (MHz)				829	836.5	844				
10	PI/2 BPSK	1	1	22.64	22.75	22.70	-5.0	0.0354	0.0363	0.0359
10	QPSK	1	1	22.56	22.54	22.63	-5.0	0.0348	0.0346	0.0353
10	16QAM	1	1	21.64	21.82	21.55	-5.0	0.0281	0.0293	0.0275
Channel				165300	167300	169300	Gain	ERP	ERP	ERP
Frequency (MHz)				826.5	836.5	846.5				
5	PI/2 BPSK	1	1	22.56	22.65	22.74	-5.0	0.0348	0.0355	0.0362
5	QPSK	1	1	22.46	22.57	22.56	-5.0	0.0340	0.0348	0.0348
5	16QAM	1	1	21.60	21.79	21.52	-5.0	0.0279	0.0291	0.0274



5G NR n66:

BW [MHz]	Modulation	RB Size	RB Offset	Power Low Ch. / Freq.	Power Middle Ch. / Freq.	Power High Ch. / Freq.	Gain	EIRP	EIRP	EIRP
Channel				346000	349000	352000				
Frequency (MHz)				1730	1745	1760		L	M	H
40	PI/2 BPSK	1	1	23.18	23.31	23.25	-1.91	0.1340	0.1380	0.1361
40	QPSK	1	1	23.28	23.50	23.45	-1.91	0.1371	0.1442	0.1426
40	QPSK	1	108	23.25	23.57	23.47	-1.91	0.1361	0.1466	0.1432
40	QPSK	1	214	23.29	23.41	23.23	-1.91	0.1374	0.1413	0.1355
40	QPSK	108	0	22.56	22.53	22.54	-1.91	0.1161	0.1153	0.1156
40	QPSK	108	54	23.35	23.36	23.28	-1.91	0.1393	0.1396	0.1371
40	QPSK	108	108	22.59	22.56	22.64	-1.91	0.1169	0.1161	0.1183
40	QPSK	216	0	22.52	22.50	22.54	-1.91	0.1151	0.1146	0.1156
40	16QAM	1	1	22.53	22.64	22.74	-1.91	0.1153	0.1183	0.1211
40	64QAM	1	1	20.64	20.80	20.69	-1.91	0.0746	0.0774	0.0755
40	256QAM	1	1	18.80	18.86	18.78	-1.91	0.0489	0.0495	0.0486
Channel				345000	349000	353000	Gain	EIRP	EIRP	EIRP
Frequency (MHz)				1725	1745	1765				
30	PI/2 BPSK	1	1	23.30	23.27	23.24	-1.91	0.1377	0.1368	0.1358
30	QPSK	1	1	23.41	23.45	23.35	-1.91	0.1413	0.1426	0.1393
30	16QAM	1	1	22.49	22.58	22.69	-1.91	0.1143	0.1167	0.1197
Channel				344500	349000	353500	Gain	EIRP	EIRP	EIRP
Frequency (MHz)				1722.5	1745	1767.5				
25	PI/2 BPSK	1	1	23.12	23.16	23.02	-1.91	0.1321	0.1334	0.1291
25	QPSK	1	1	22.98	22.85	23.14	-1.91	0.1279	0.1242	0.1327
25	16QAM	1	1	22.45	22.51	22.63	-1.91	0.1132	0.1148	0.1180
Channel				344000	349000	354000	Gain	EIRP	EIRP	EIRP
Frequency (MHz)				1720	1745	1770				
20	PI/2 BPSK	1	1	23.26	23.28	23.19	-1.91	0.1365	0.1371	0.1343
20	QPSK	1	1	23.38	23.45	23.43	-1.91	0.1403	0.1426	0.1419
20	16QAM	1	1	22.46	22.58	22.63	-1.91	0.1135	0.1167	0.1180
Channel				343500	349000	354500	Gain	EIRP	EIRP	EIRP
Frequency (MHz)				1717.5	1745	1772.5				
15	PI/2 BPSK	1	1	23.20	23.24	23.15	-1.91	0.1346	0.1358	0.1330
15	QPSK	1	1	23.35	23.41	23.29	-1.91	0.1393	0.1413	0.1374
15	16QAM	1	1	22.41	22.52	22.63	-1.91	0.1122	0.1151	0.1180
Channel				343000	349000	355000	Gain	EIRP	EIRP	EIRP
Frequency (MHz)				1715	1745	1775				
10	PI/2 BPSK	1	1	23.07	23.11	23.08	-1.91	0.1306	0.1318	0.1309
10	QPSK	1	1	23.24	23.30	23.26	-1.91	0.1358	0.1377	0.1365
10	16QAM	1	1	22.40	22.53	22.65	-1.91	0.1119	0.1153	0.1186
Channel				342500	349000	355500	Gain	EIRP	EIRP	EIRP
Frequency (MHz)				1712.5	1745	1777.5				
5	PI/2 BPSK	1	1	23.18	23.29	23.19	-1.91	0.1340	0.1374	0.1343
5	QPSK	1	1	23.25	23.34	23.26	-1.91	0.1361	0.1390	0.1365
5	16QAM	1	1	22.39	22.55	22.61	-1.91	0.1117	0.1159	0.1175



FR1 n2

Peak-to-Average Ratio

Mode	FR1 n2 / 20MHz / DFT-S OFDM				
Mod.	PI/2 BPSK	QPSK			Limit: 13dB
RB Size	Full RB	Full RB			Result
Middle CH	3.94	5.1			PASS



FR1 n2 / 20MHz / DFT-S OFDM / Middle Channel / Full RB

PI/2 BPSK

QPSK

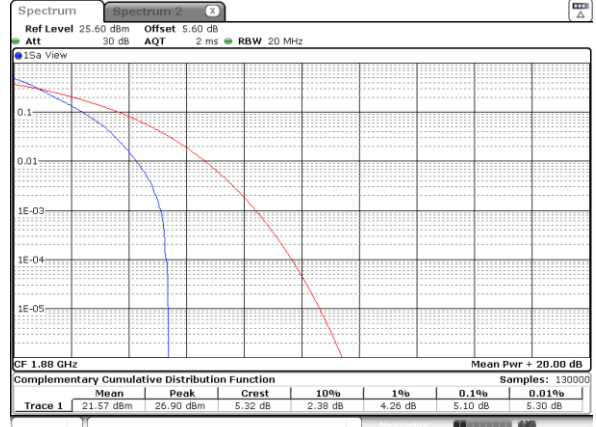
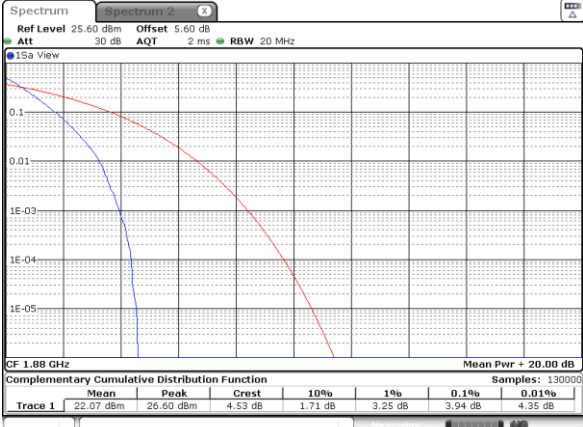

Date: 7.SEP.2022 19:07:15

Date: 7.SEP.2022 19:07:05



26dB Bandwidth

Mode	FR1 n2 : 26dBW (MHz) / DFT OFDM							
BW	5MHz		10MHz		15MHz		20MHz	
Mod.	QPSK		QPSK		QPSK		QPSK	
Middle CH	5.05		10.17		14.99		20.02	
Mod.	16QAM	64QAM	16QAM	64QAM	16QAM	64QAM	16QAM	64QAM
Middle CH	5.25	5.21	10.21	10.17	15.05	15.32	20.1	20.02
Mod.	256QAM		256QAM		256QAM		256QAM	
Middle CH	5.06		10.27		15.23		19.82	



FR1 n2 / 5MHz / CP OFDM / Middle Channel / Full RB

QPSK

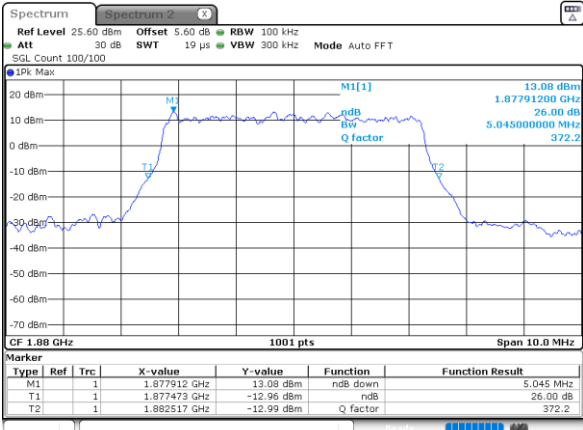

Date: 7,SEP,2022 19:16:50

16QAM

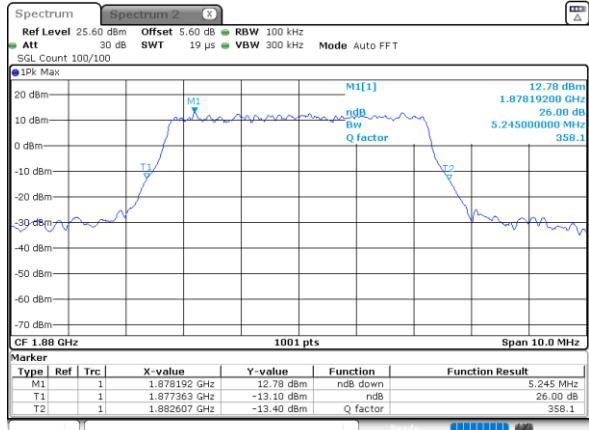

Date: 7,SEP,2022 19:17:17

64QAM

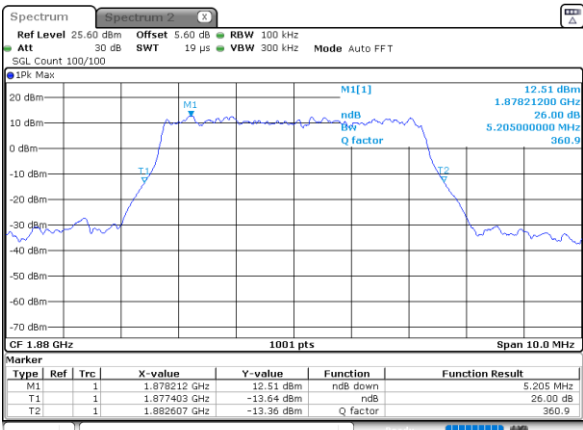

Date: 7,SEP,2022 19:17:44

256QAM

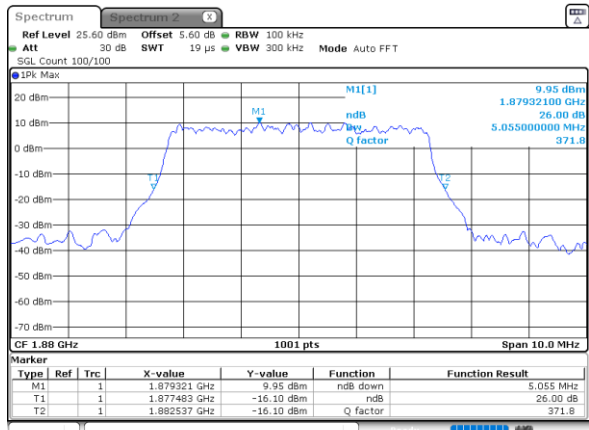

Date: 7,SEP,2022 19:18:10



FR1 n2 / 10MHz / CP OFDM / Middle Channel / Full RB

QPSK

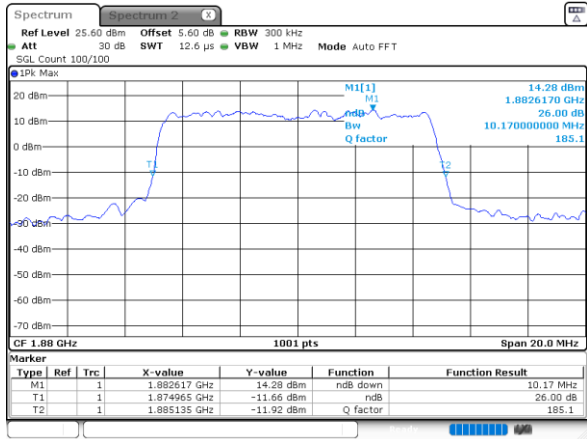

Date: 7,SEP,2022 19:21:17

16QAM

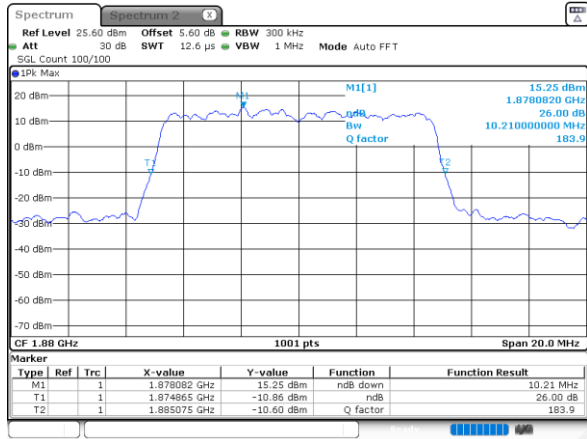

Date: 7,SEP,2022 19:21:00

64QAM

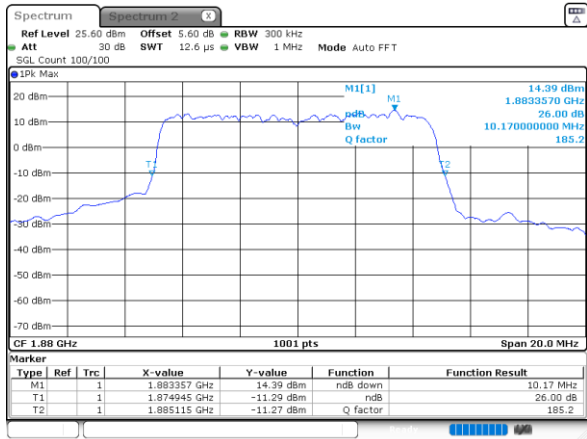

Date: 7,SEP,2022 19:20:41

256QAM

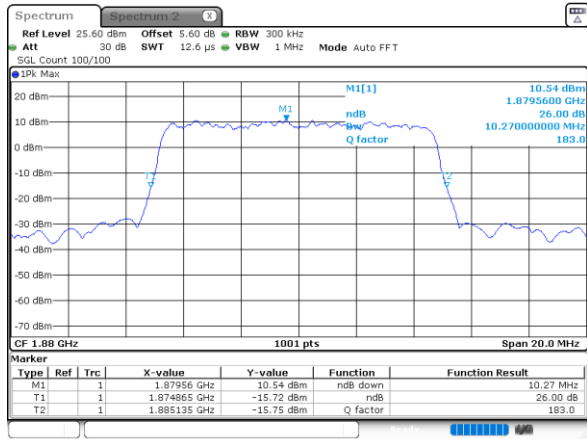

Date: 7,SEP,2022 19:20:22



FR1 n2 / 15MHz / CP OFDM / Middle Channel / Full RB

QPSK

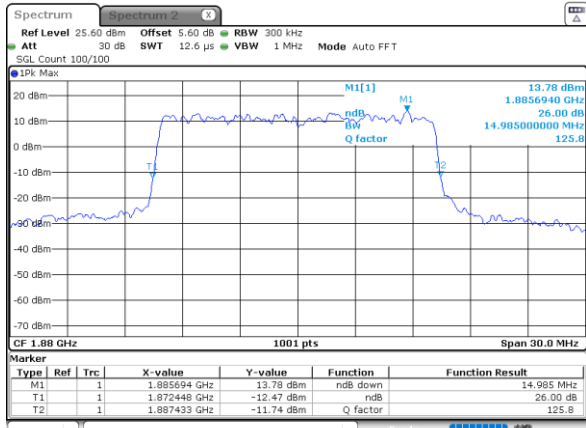

Date: 7,SEP,2022 19:18:13

16QAM

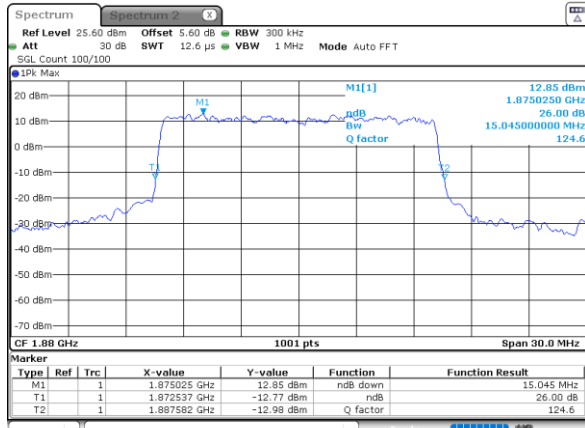

Date: 7,SEP,2022 19:18:31

64QAM

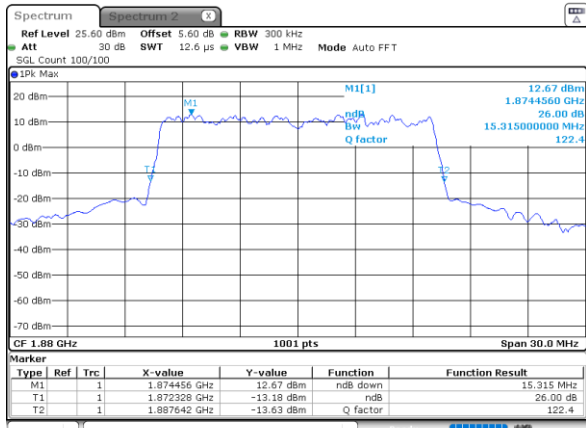

Date: 7,SEP,2022 19:18:47

256QAM

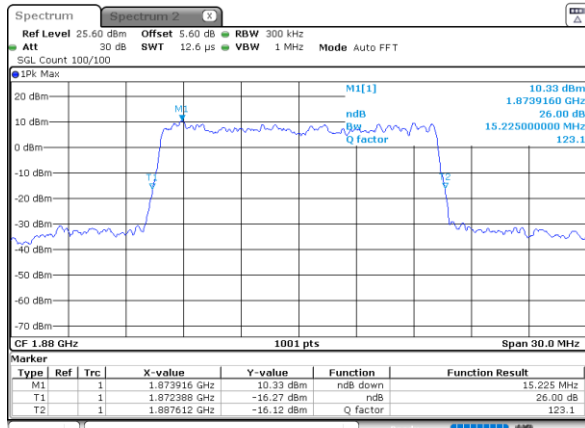

Date: 7,SEP,2022 19:19:34



FR1 n2 / 20MHz / DFT-S OFDM / Middle Channel / Full RB

QPSK

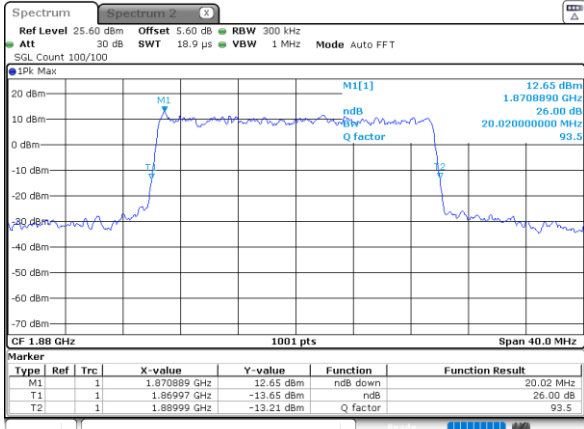

Date: 7,SEP,2022 19:04:21

16QAM

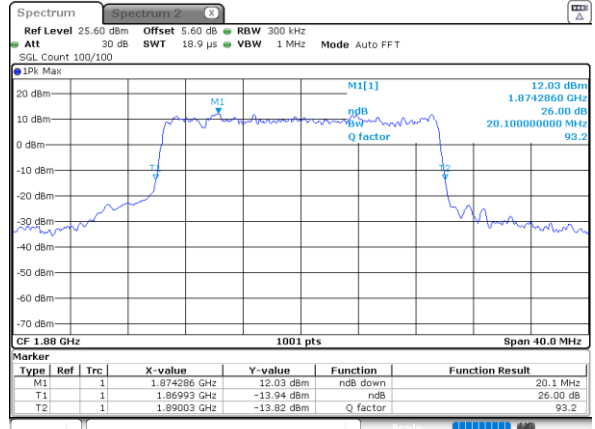

Date: 7,SEP,2022 19:04:49

64QAM

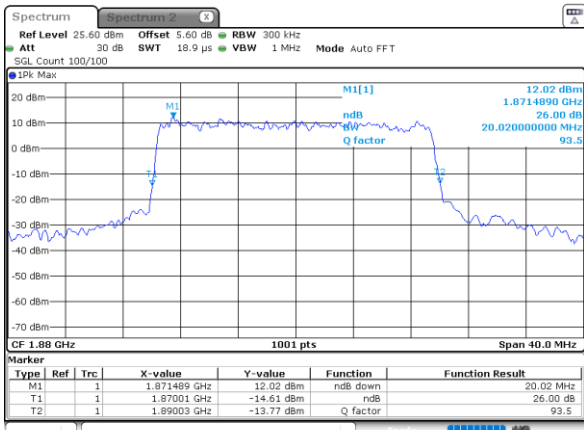

Date: 7,SEP,2022 19:05:09

256QAM

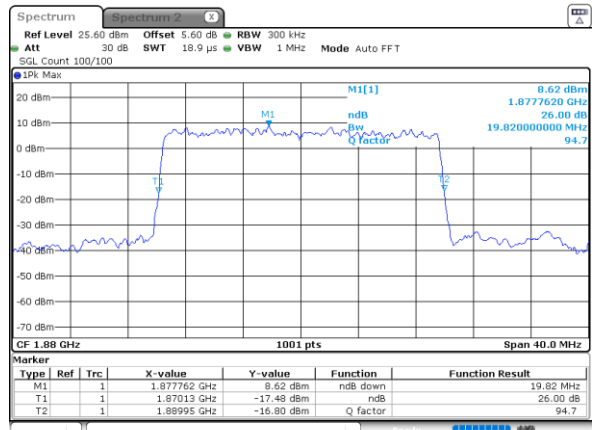

Date: 7,SEP,2022 19:05:45



Occupied Bandwidth

Mode	FR1 n2 : 99%OBW (MHz) / CP OFDM							
BW	5MHz		10MHz		15MHz		20MHz	
Mod.	QPSK		QPSK		QPSK		QPSK	
Middle CH	4.48		9.45		14.15		18.94	
Mod.	16QAM	64QAM	16QAM	64QAM	16QAM	64QAM	16QAM	64QAM
Middle CH	4.50	4.50	9.37	9.41	14.12	14.18	18.94	18.90
Mod.	256QAM		256QAM		256QAM		256QAM	
Middle CH	4.54		9.43		14.12		18.90	



FR1 n2 / 5MHz / CP OFDM / Middle Channel / Full RB

QPSK

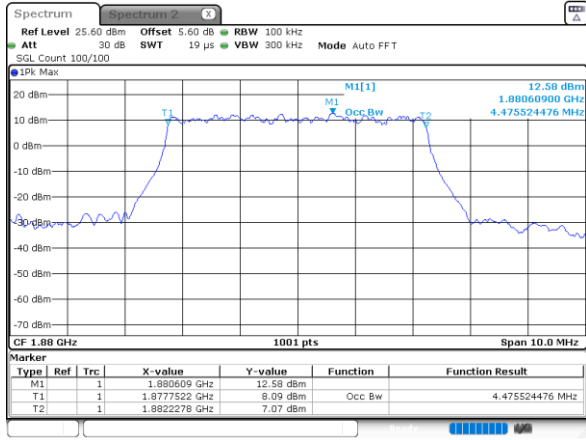

Date: 7,SEP,2022 19:36:43

16QAM

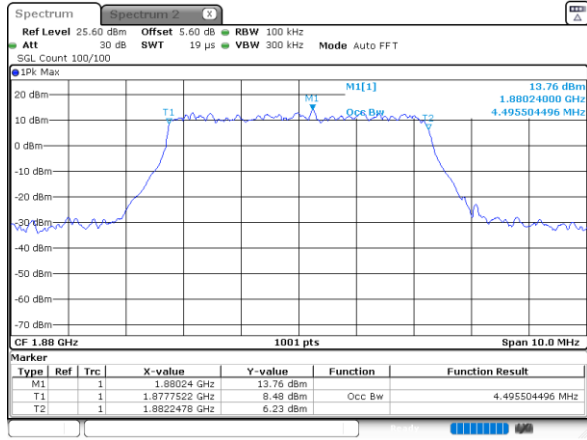

Date: 7,SEP,2022 19:37:03

64QAM

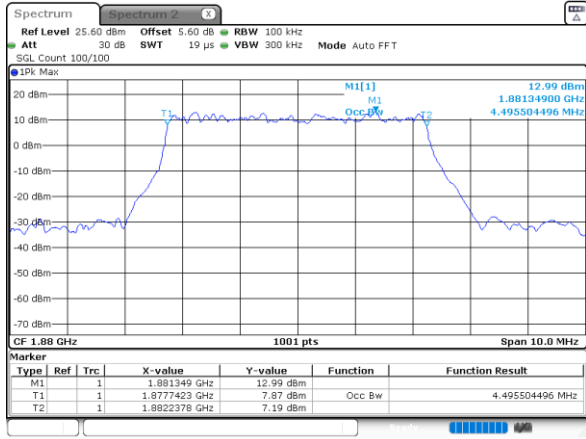

Date: 7,SEP,2022 19:37:38

256QAM

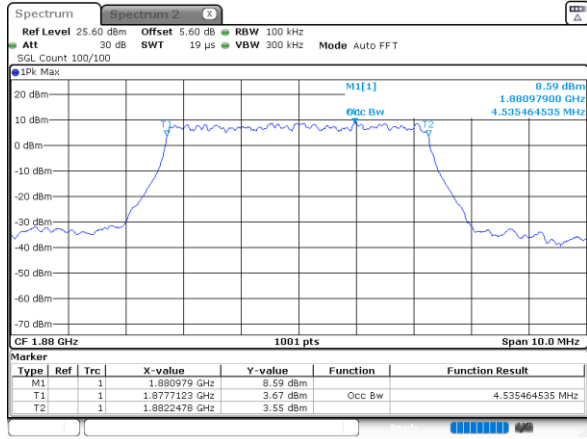

Date: 7,SEP,2022 19:38:02



FR1 n2 / 10MHz / CP OFDM / Middle Channel / Full RB

QPSK

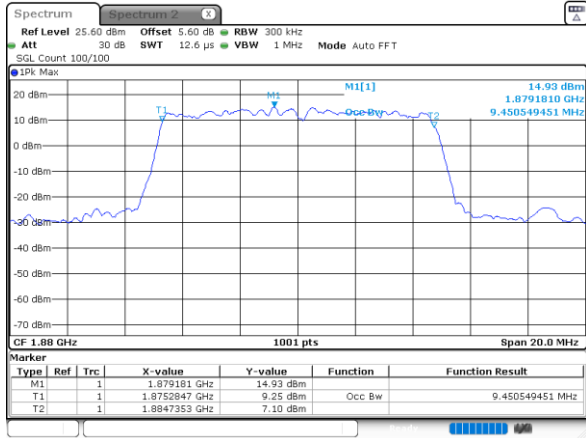

Date: 7,SEP,2022 19:21:11

16QAM

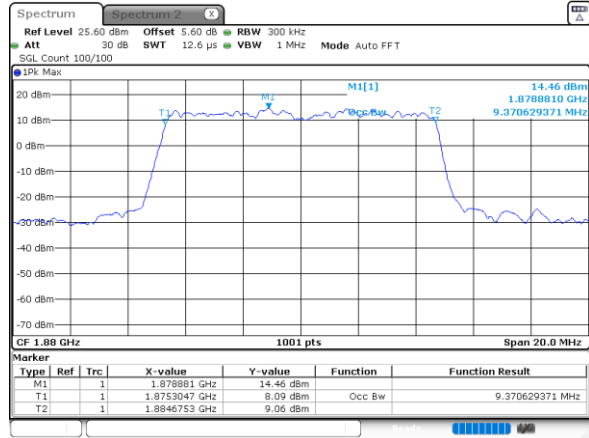

Date: 7,SEP,2022 19:20:53

64QAM

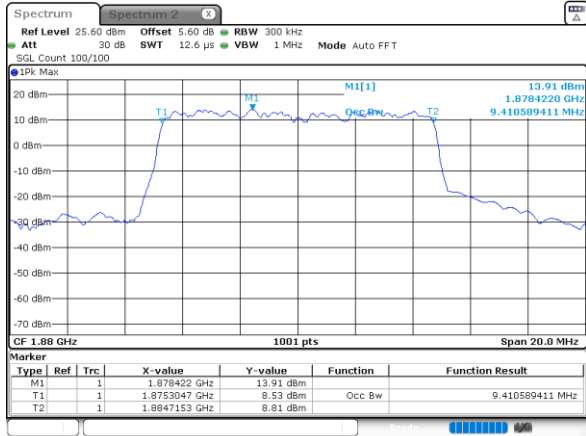

Date: 7,SEP,2022 19:20:33

256QAM

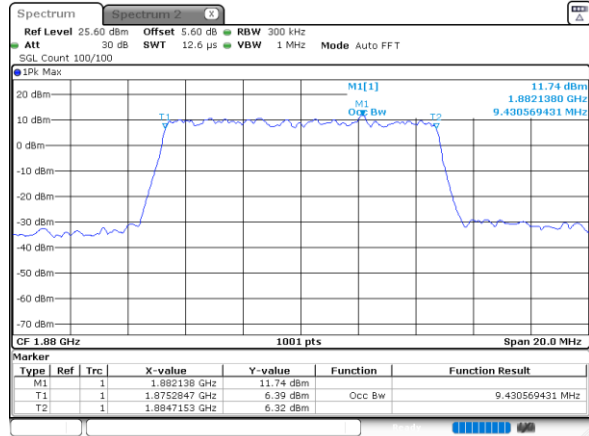

Date: 7,SEP,2022 19:20:17



FR1 n2 / 15MHz / CP OFDM / Middle Channel / Full RB

QPSK

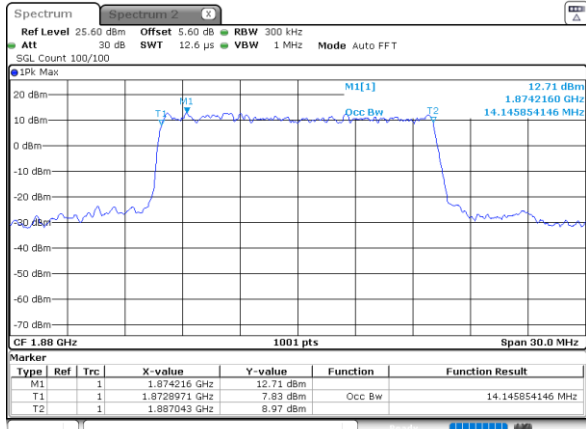

Date: 7,SEP,2022 19:18:05

16QAM

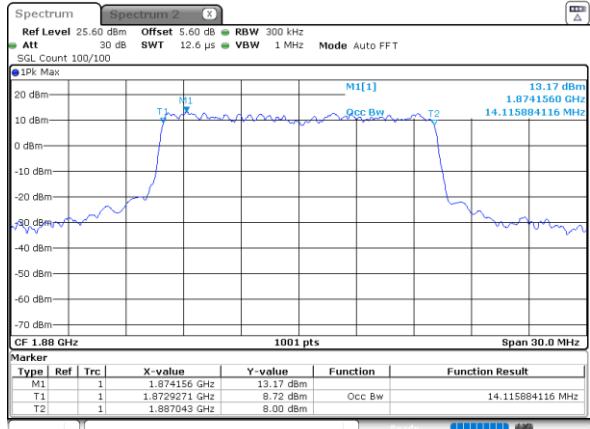

Date: 7,SEP,2022 19:18:24

64QAM

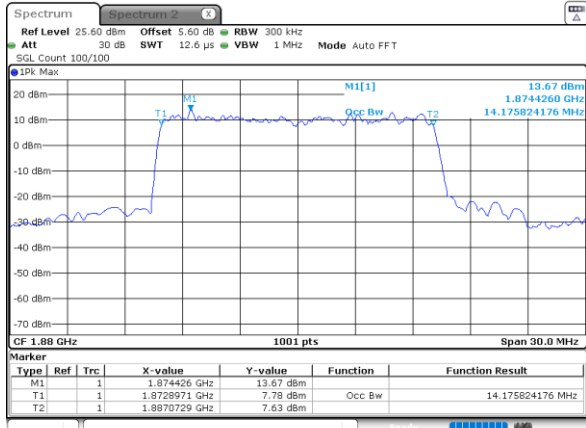

Date: 7,SEP,2022 19:18:41

256QAM

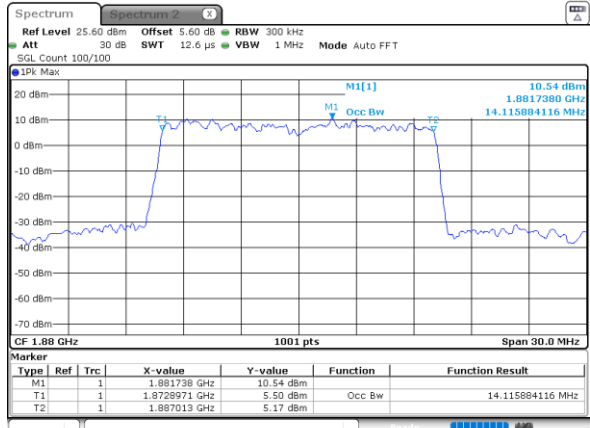

Date: 7,SEP,2022 19:19:22



FR1 n2 / 20MHz / DFT-S OFDM / Middle Channel / Full RB

QPSK

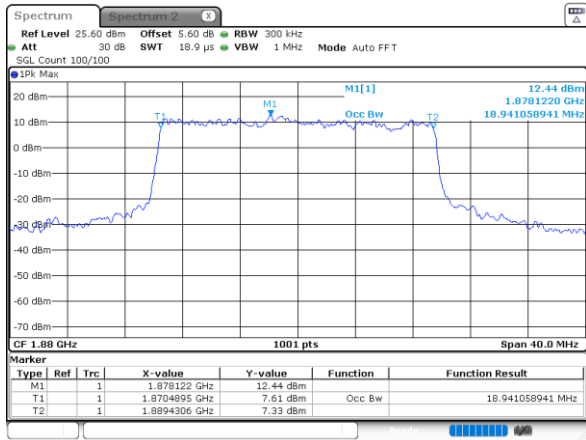

Date: 7,SEP,2022 19:04:14

16QAM

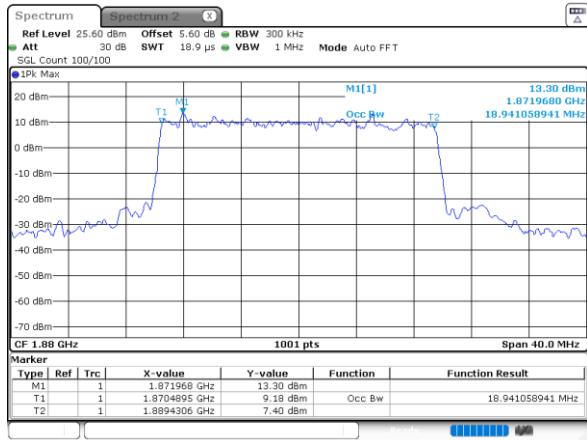

Date: 7,SEP,2022 19:04:43

64QAM

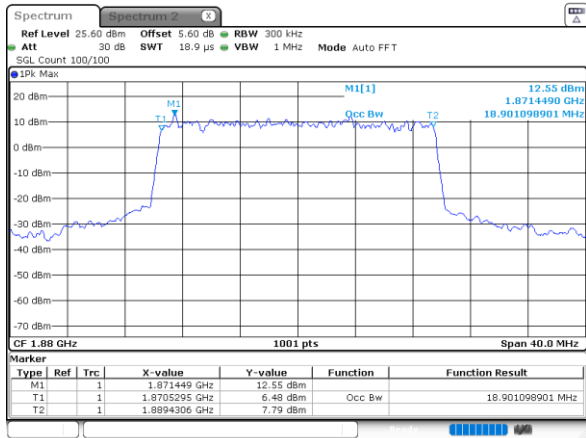

Date: 7,SEP,2022 19:04:59

256QAM

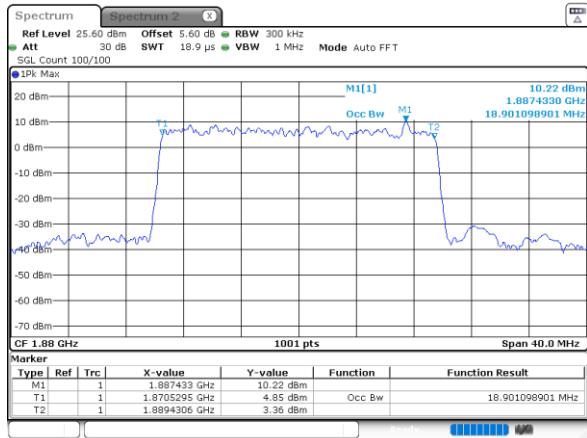

Date: 7,SEP,2022 19:05:40



Conducted Band Edge

FR1 n2 / 5MHz / DFT-S OFDM / PI/2 BPSK

Lowest Band Edge / 1RB0

Highest Band Edge / 1RBmax

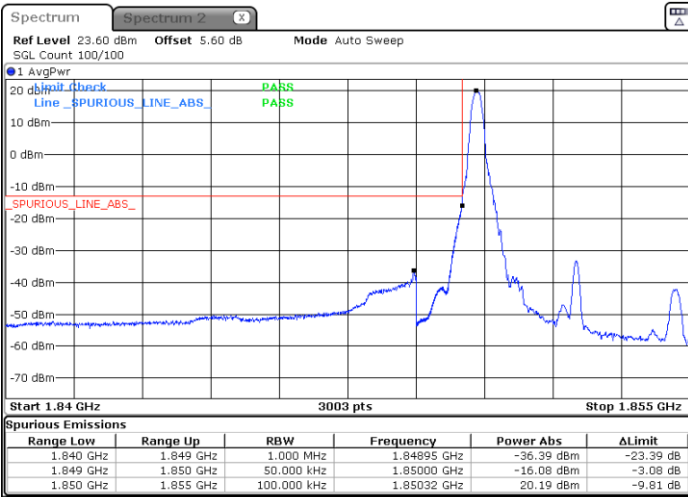

Date: 7.SEP.2022 19:44:26

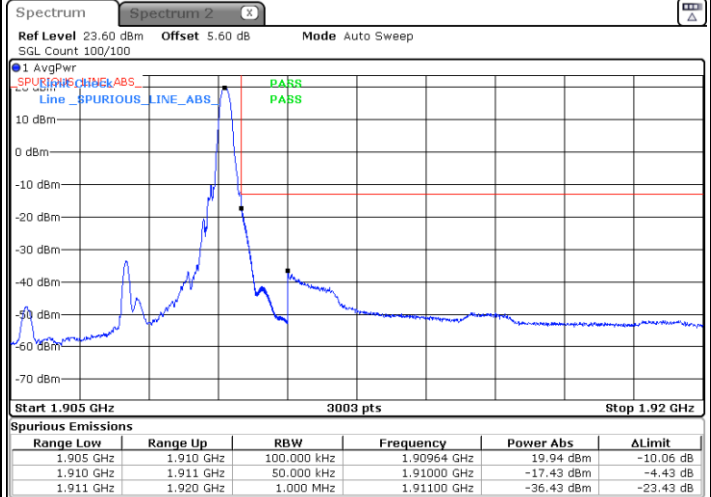

Date: 7.SEP.2022 19:48:49

Lowest Band Edge / Full RB

Highest Band Edge / Full RB

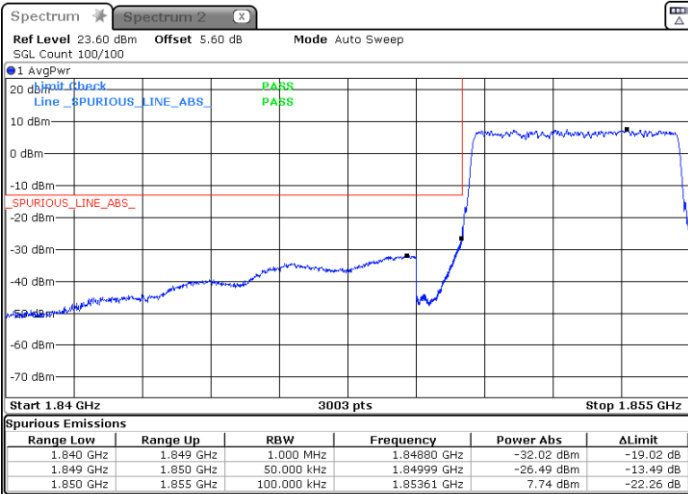

Date: 7.SEP.2022 19:45:28

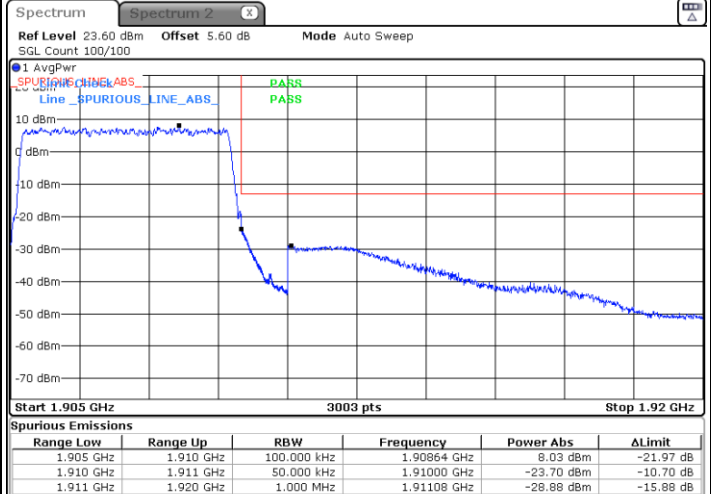

Date: 7.SEP.2022 19:47:46



FR1 n2 / 5MHz / DFT-S OFDM / QPSK

Lowest Band Edge / 1RB0

Highest Band Edge / 1RBmax

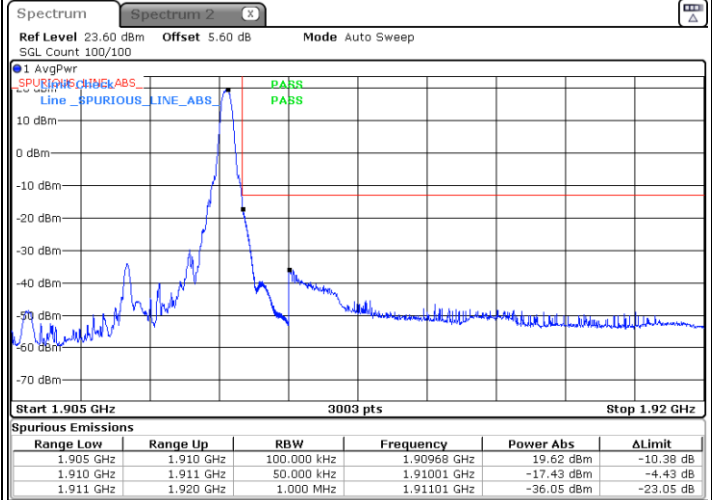
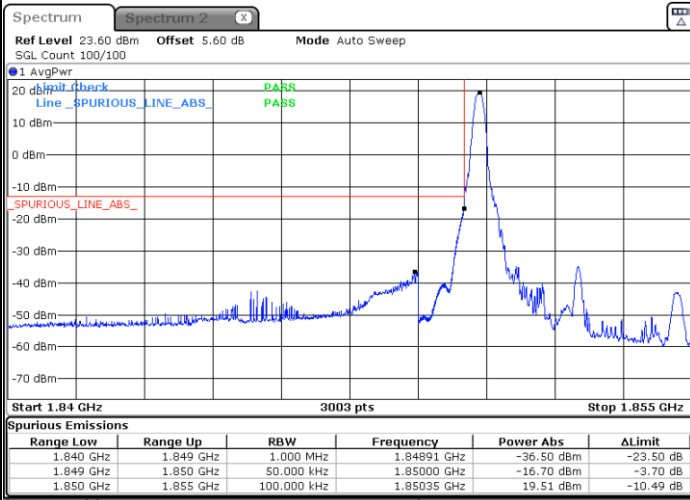

Date: 7.SEP.2022 19:43:41

Date: 7.SEP.2022 19:49:54

Lowest Band Edge / Full RB

Highest Band Edge / Full RB

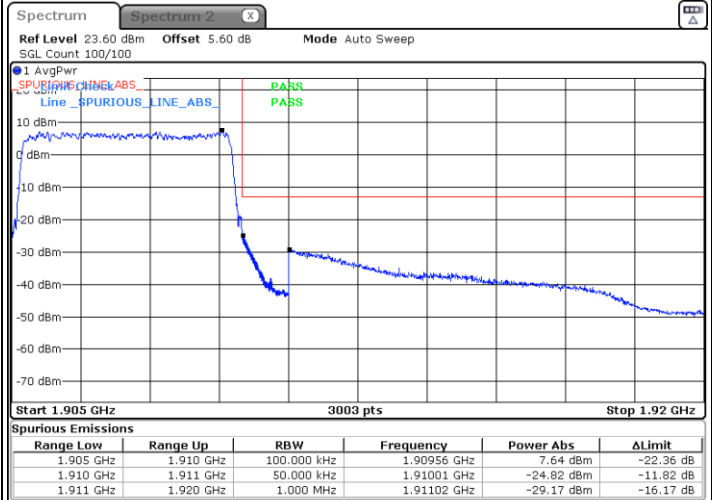
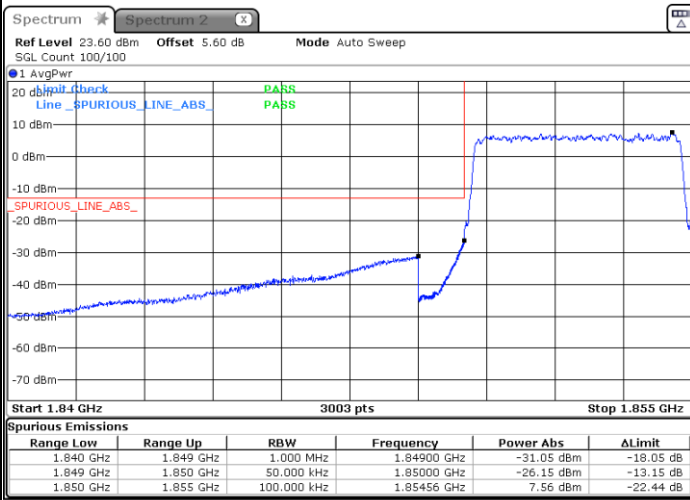

Date: 7.SEP.2022 19:46:13

Date: 7.SEP.2022 19:46:59



FR1 n2 / 10MHz / DFT-s-OFDM / PI/2 BPSK

Lowest Band Edge / 1RB0

Highest Band Edge / 1RBmax

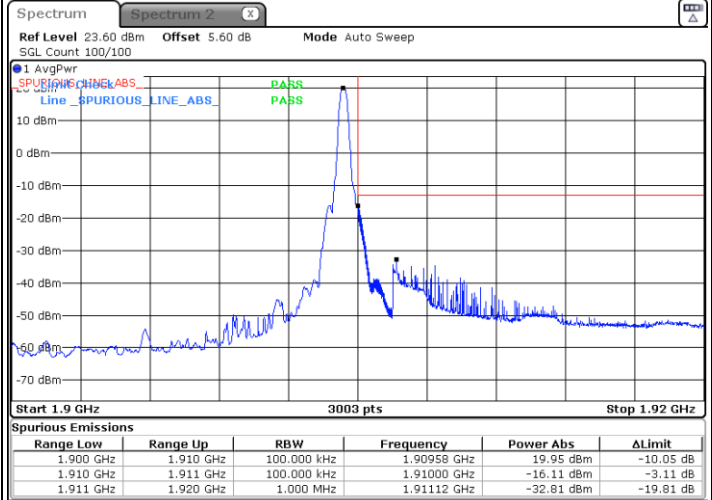
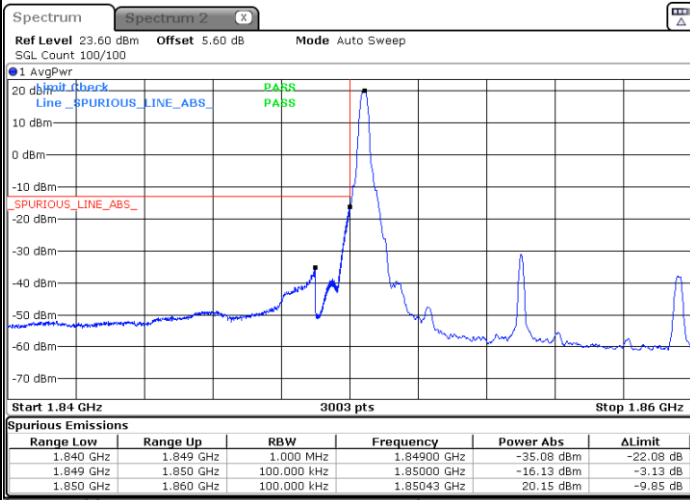

Date: 7.SEP.2022 19:29:25

Date: 7.SEP.2022 19:32:29

Lowest Band Edge / Full RB

Highest Band Edge / Full RB

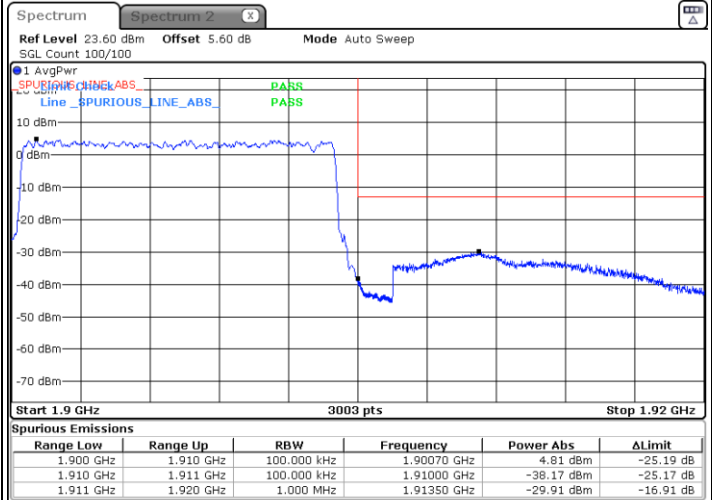
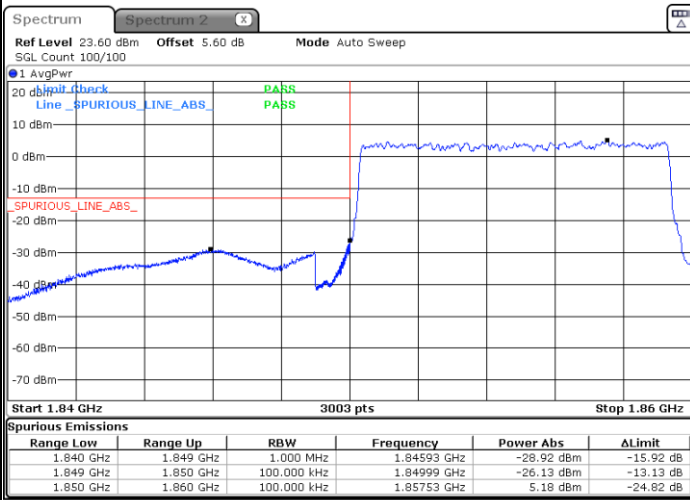

Date: 7.SEP.2022 19:30:32

Date: 7.SEP.2022 19:31:29



FR1 n2 / 10MHz / DFT-s-OFDM / QPSK

Lowest Band Edge / 1RB0

Highest Band Edge / 1RBmax

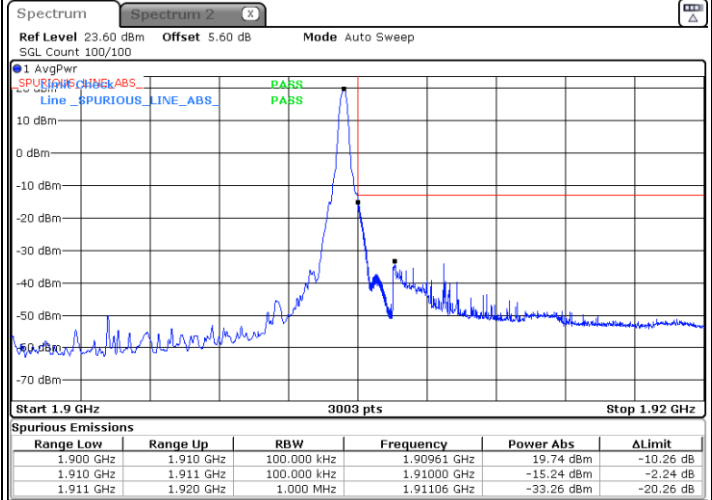
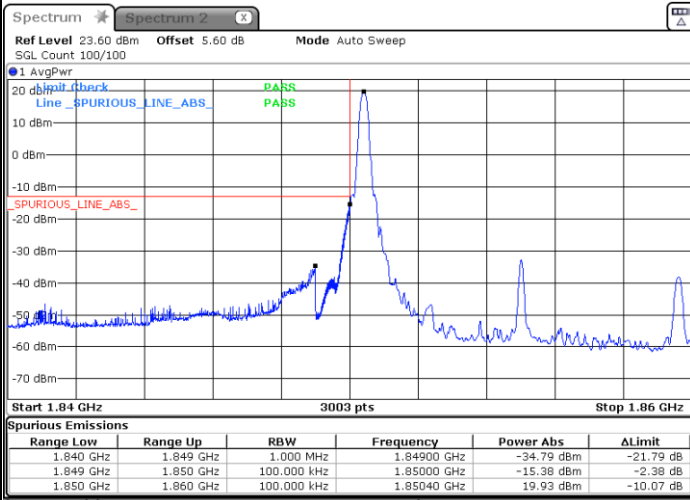

Date: 7.SEP.2022 19:29:59

Date: 7.SEP.2022 19:32:14

Lowest Band Edge / Full RB

Highest Band Edge / Full RB

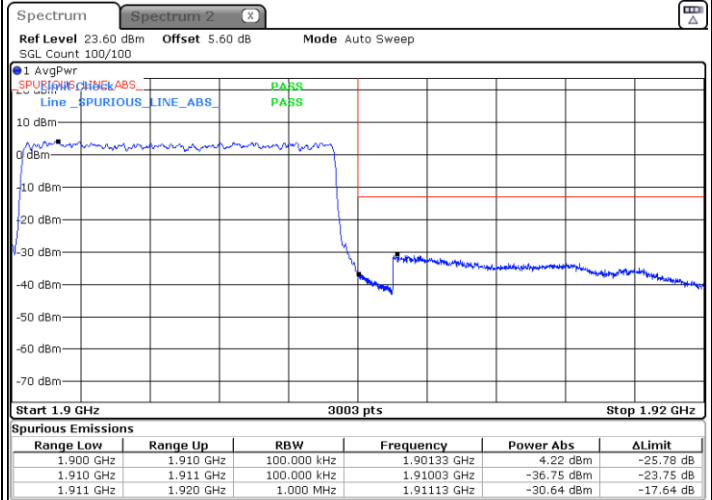
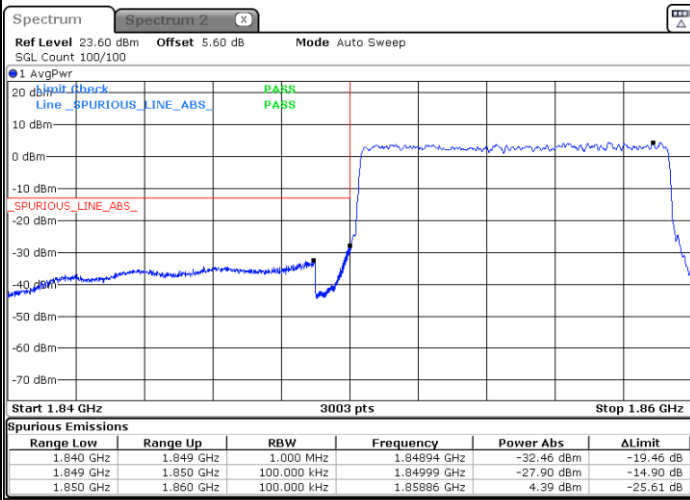

Date: 7.SEP.2022 19:30:17

Date: 7.SEP.2022 19:31:56



FR1 n2 / 20MHz / DFT-s-OFDM / PI/2 BPSK

Lowest Band Edge / 1RB0

Highest Band Edge / 1RBmax

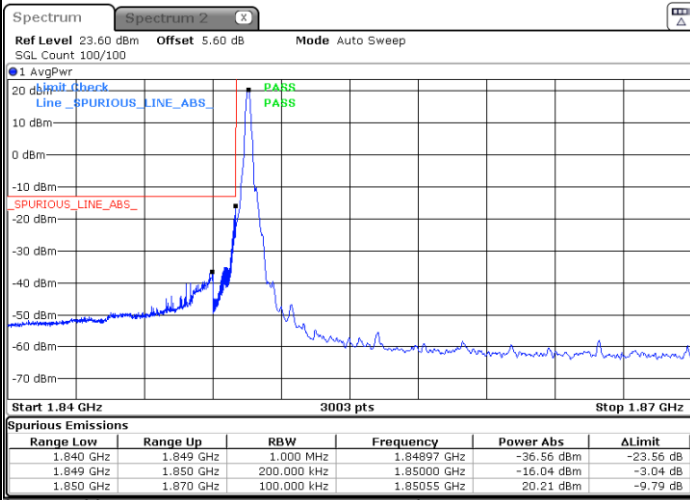

Date: 7.SEP.2022 19:12:08

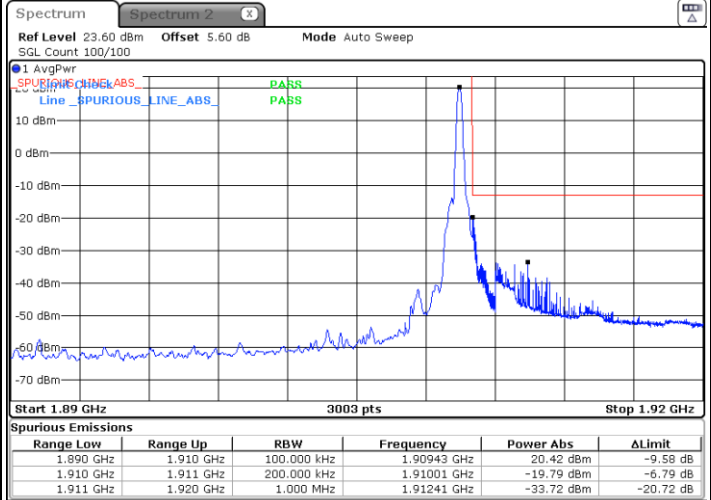

Date: 7.SEP.2022 19:14:48

Lowest Band Edge / Full RB

Highest Band Edge / Full RB

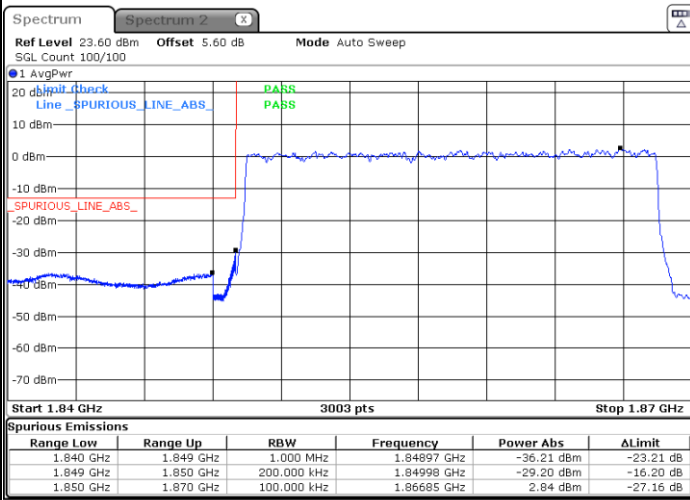

Date: 7.SEP.2022 19:13:19

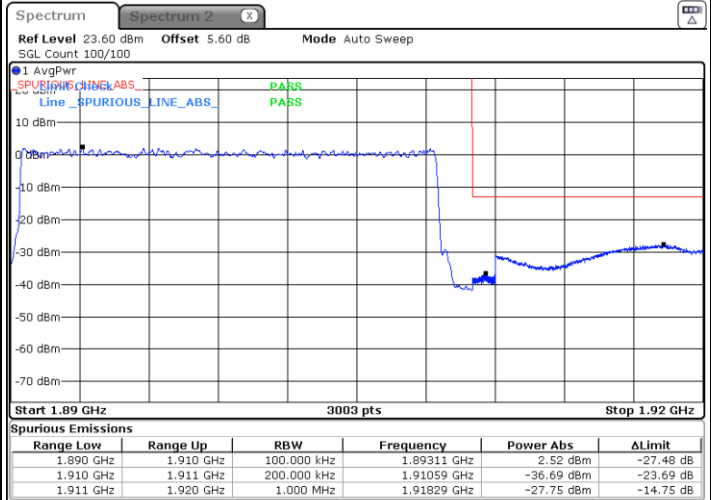

Date: 7.SEP.2022 19:13:50



FR1 n2 / 20MHz / DFT-s-OFDM / QPSK

Lowest Band Edge / 1RB0

Highest Band Edge / 1RBmax

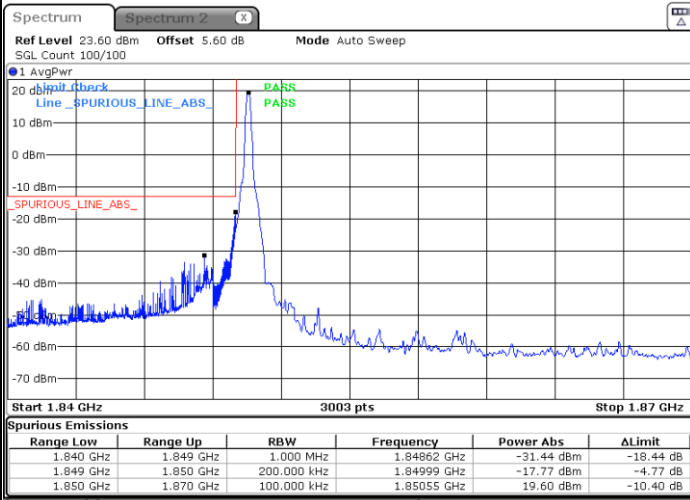

Date: 7.SEP.2022 19:12:45

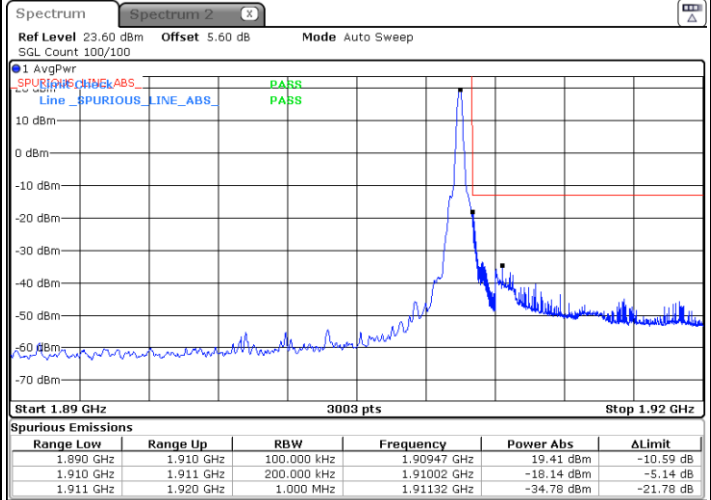

Date: 7.SEP.2022 19:14:31

Lowest Band Edge / Full RB

Highest Band Edge / Full RB

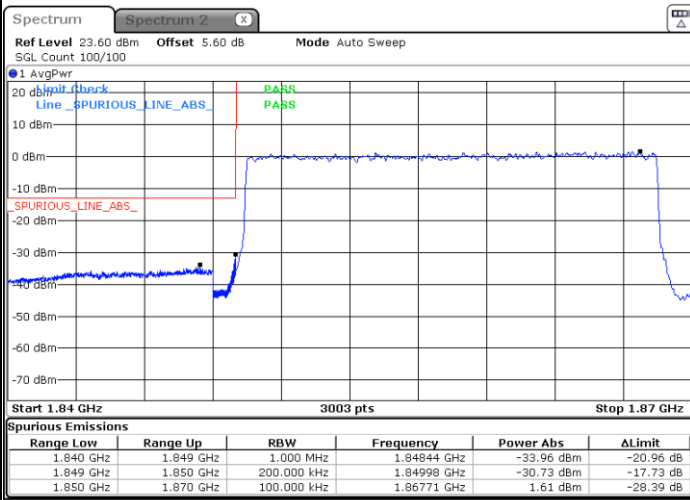

Date: 7.SEP.2022 19:13:04

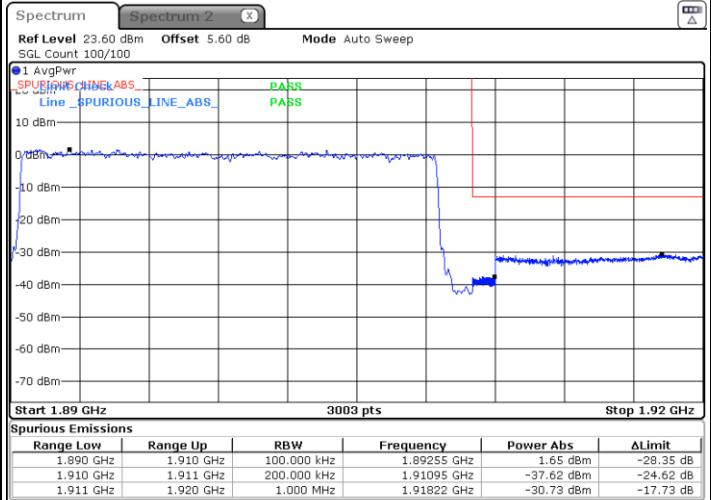

Date: 7.SEP.2022 19:14:10



Conducted Spurious Emission

FR1 n2 / 5MHz / DFT-S OFDM / BPSK

Lowest Channel / 1RB1

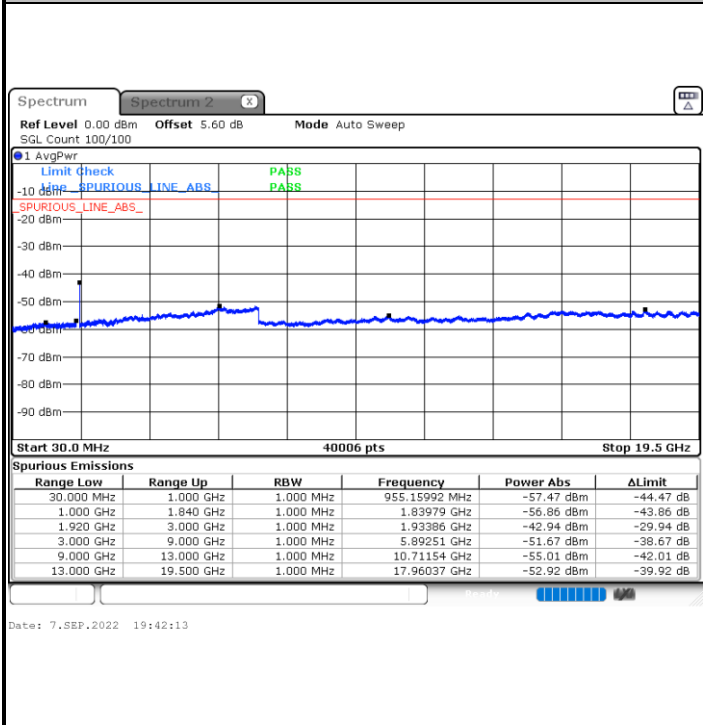

Middle Channel / 1RB1

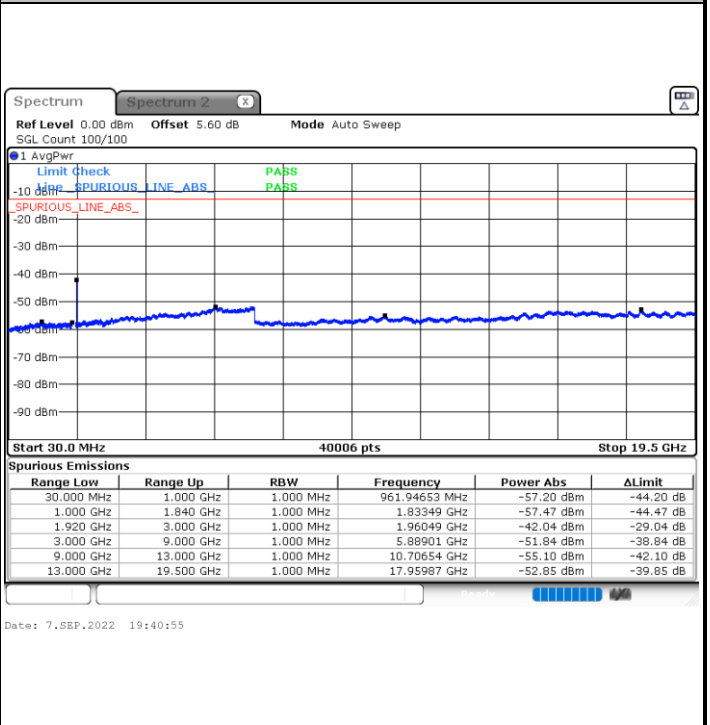

Highest Channel / 1RB1

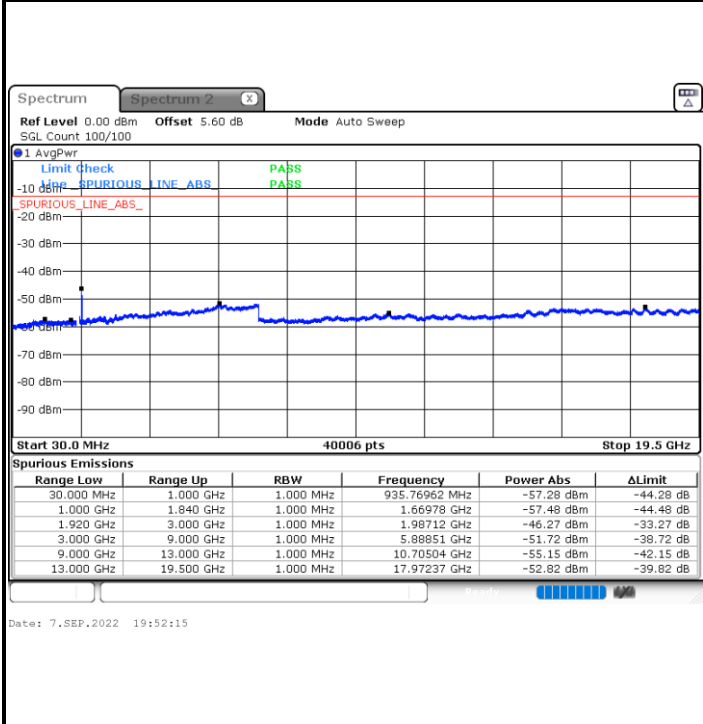



FR1 n2 / 5MHz / DFT-S OFDM / QPSK

Lowest Channel / 1RB1

Middle Channel / 1RB1

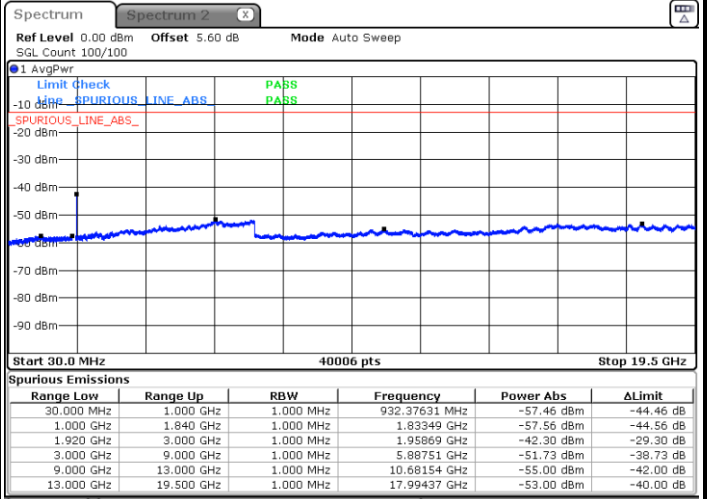
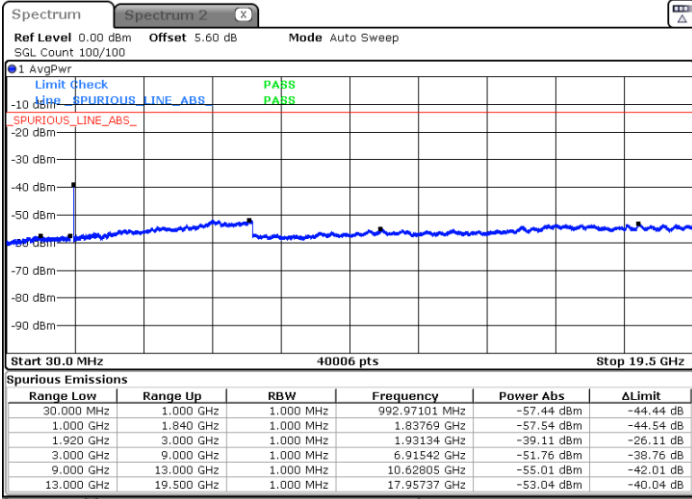

Date: 7.SEP.2022 19:43:05

Date: 7.SEP.2022 19:39:22

Highest Channel / 1RB1

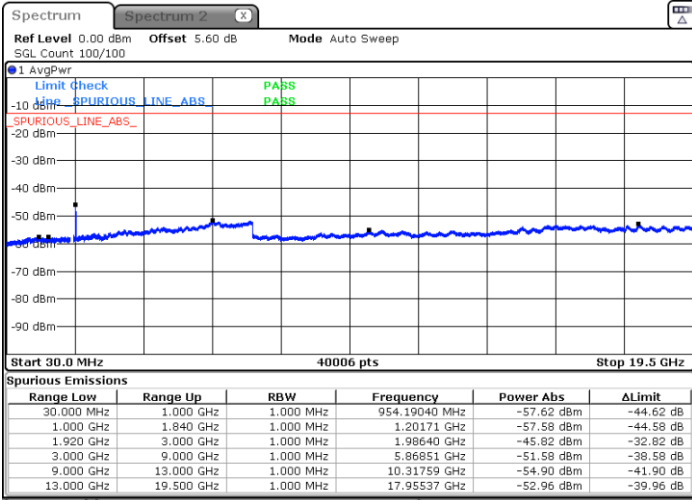

Date: 7.SEP.2022 19:51:15



FR1 n2 / 10MHz / DFT-S OFDM / BPSK

Lowest Channel / 1RB1

Middle Channel / 1RB1

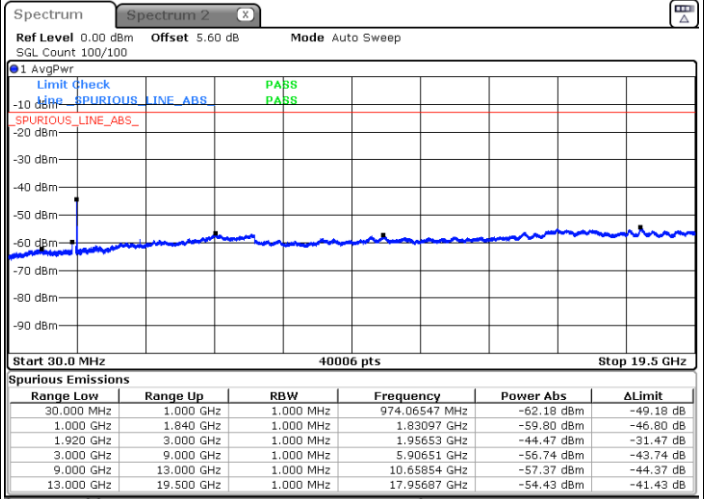
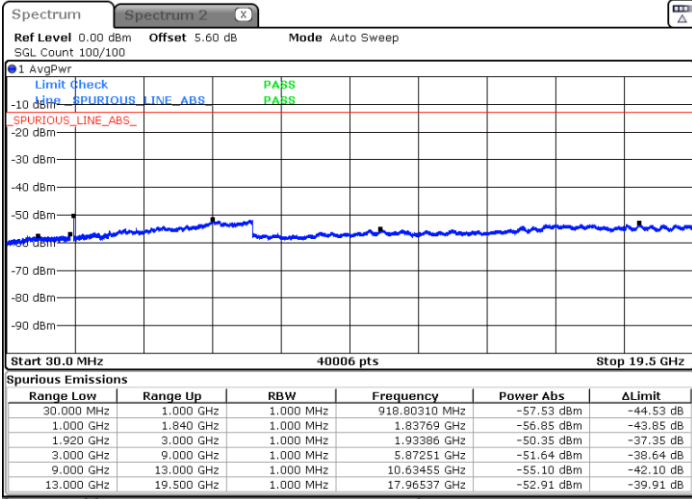

Date: 7.SEP.2022 19:29:05

Date: 7.SEP.2022 19:24:08

Highest Channel / 1RB1

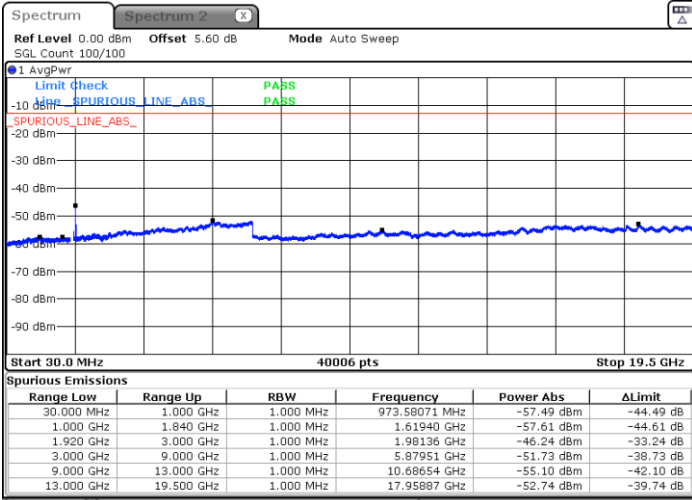

Date: 7.SEP.2022 19:34:44



FR1 n2 / 10MHz / DFT-S OFDM / QPSK

Lowest Channel / 1RB1

Middle Channel / 1RB1

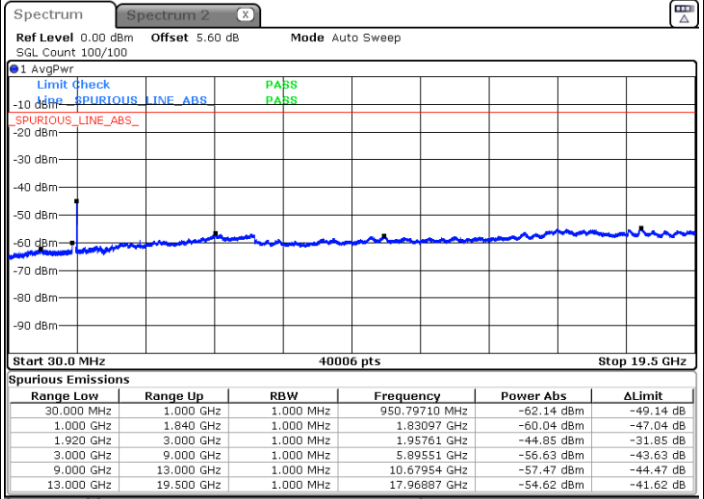
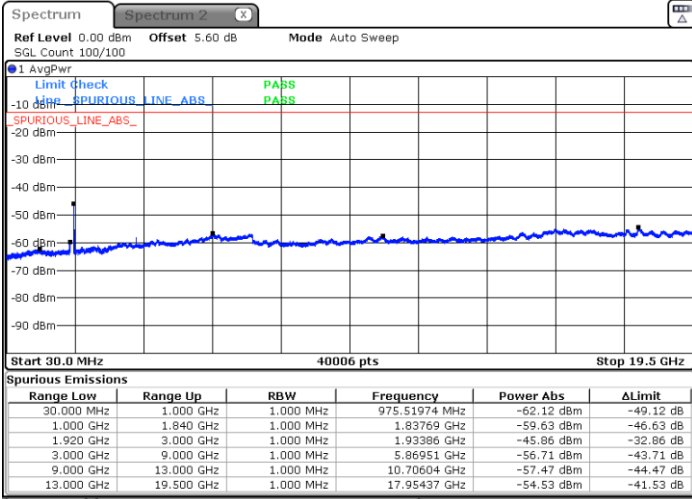

Date: 7.SEP.2022 19:27:20

Date: 7.SEP.2022 19:26:07

Highest Channel / 1RB1

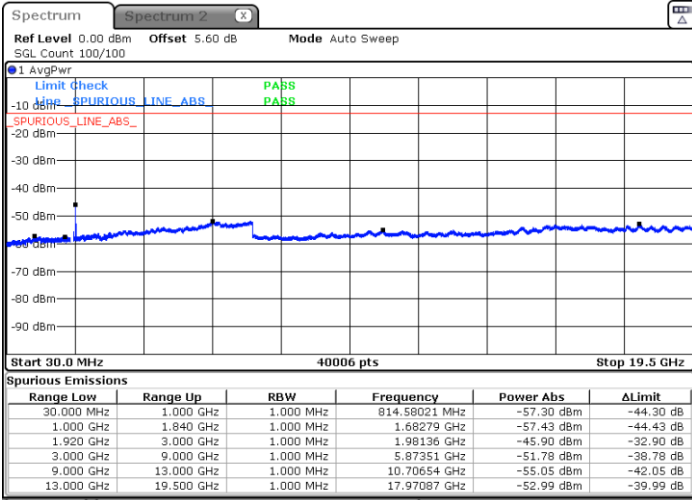

Date: 7.SEP.2022 19:35:34



FR1 n2 / 20MHz / DFT-S OFDM / BPSK

Lowest Channel / 1RB1

Middle Channel / 1RB1

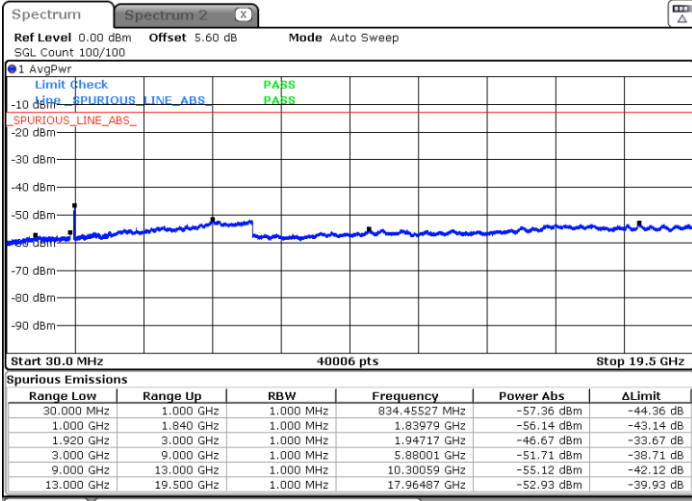

Date: 7.SEP.2022 19:11:45

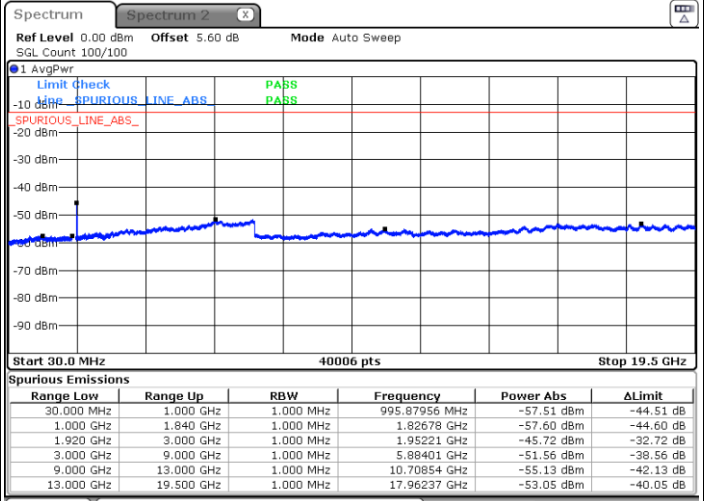

Date: 7.SEP.2022 19:08:07

Highest Channel / 1RB1

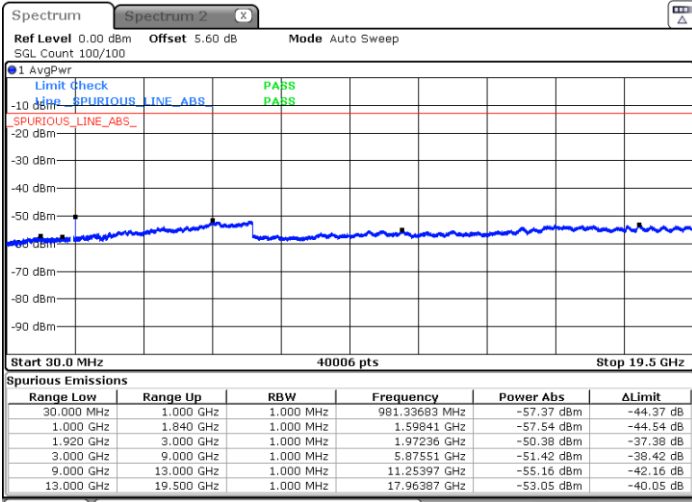

Date: 7.SEP.2022 19:16:01



FR1 n2 / 20MHz / DFT-S OFDM / QPSK

Lowest Channel / 1RB1

Middle Channel / 1RB1

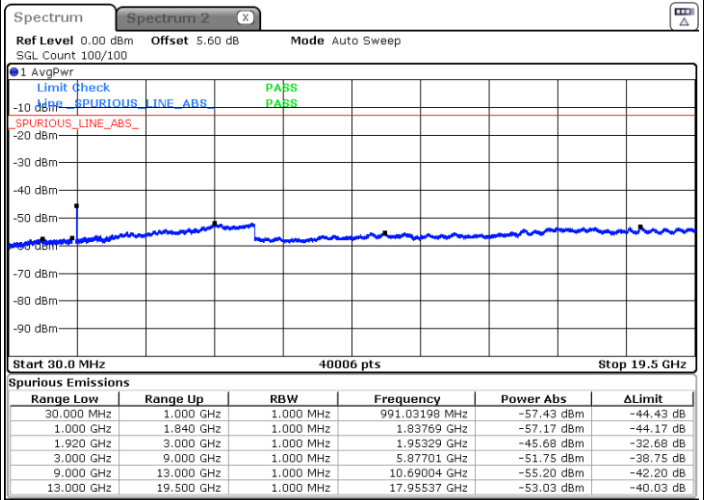
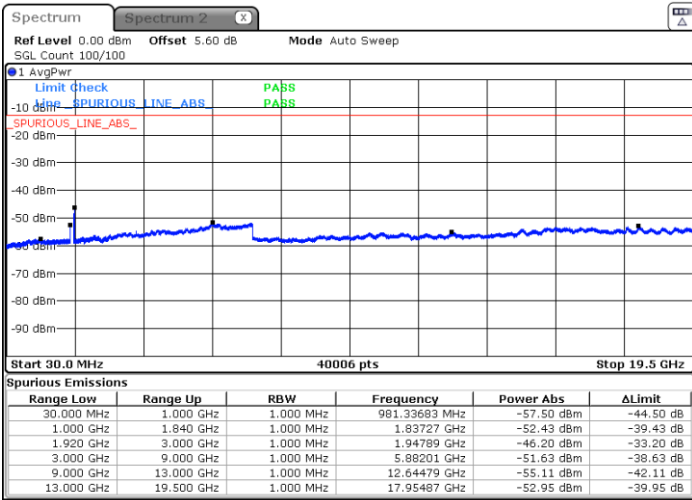

Date: 7.SEP.2022 19:10:59

Date: 7.SEP.2022 19:09:53

Highest Channel / 1RB1

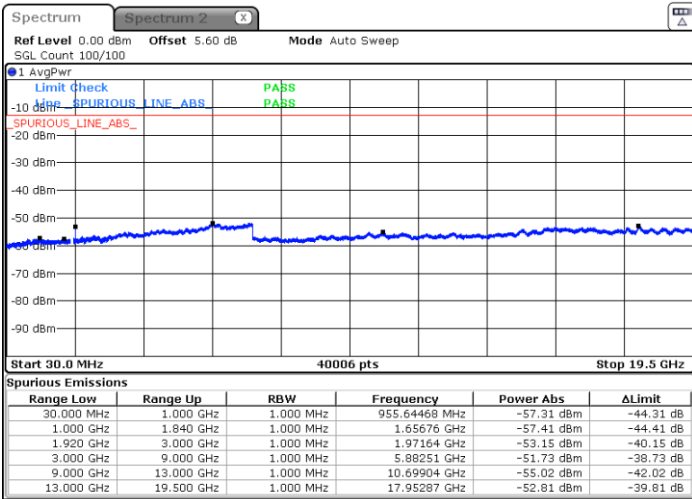

Date: 7.SEP.2022 19:16:50



Frequency Stability

Test Conditions		FR1 n2 (QPSK) / Middle Channel	Limit
Temperature (°C)	Voltage (Volt)	BW 20MHz	Note 2.
		Deviation (ppm)	Result
20	Normal Voltage	0.0012	PASS
40	Normal Voltage	0.0033	
30	Normal Voltage	0.0013	
20(Ref.)	Normal Voltage	0.0000	
10	Normal Voltage	0.0032	
0	Normal Voltage	0.0010	
-10	Normal Voltage	0.0018	
-20	Normal Voltage	0.0001	
-30	Normal Voltage	0.0020	
20	Maximum Voltage	0.0014	
20	Normal Voltage	0.0020	
20	Battery End Point	0.0011	

Note:

1. Normal Voltage =3.89V. ; Battery End Point (BEP) =3.4V. ; Maximum Voltage =4.48 V.
2. Note: The frequency fundamental emissions stay within the authorized frequency block.



FR1 n5

Peak-to-Average Ratio

Mode	FR1 n5 / 20MHz / DFT-S OFDM				
Mod.	PI/2 BPSK	QPSK			Limit: 13dB
RB Size	Full RB	Full RB			Result
Middle CH	3.22	4.20			PASS



FR1 n5 / 20MHz / DFT-S OFDM / Middle Channel / Full RB

PI/2 BPSK

QPSK

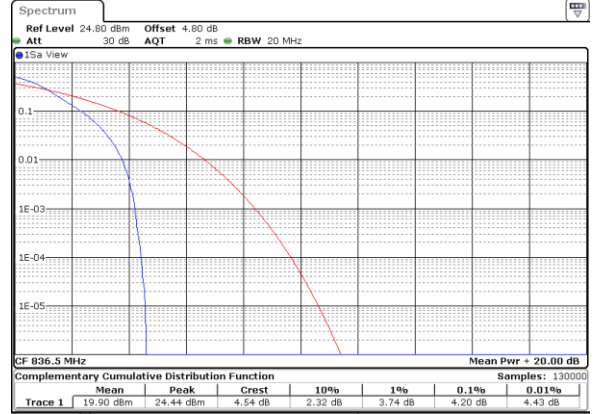
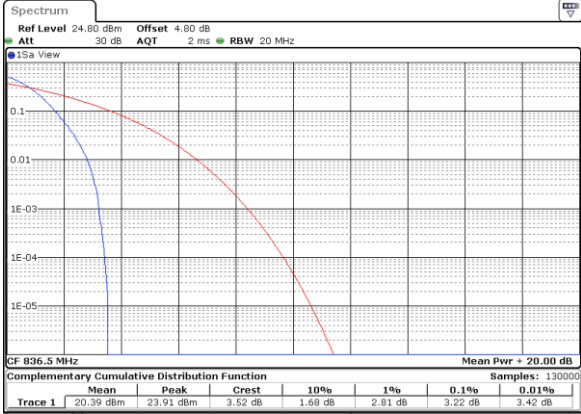

Date: 9,SEP,2022 03:33:56

Date: 9,SEP,2022 03:34:09



26dB Bandwidth

Mode	FR1 n5 : 26dBW (MHz) / CP OFDM									
BW	5M					10M				
Mod.	QPSK	16QAM	64QAM	256QAM		QPSK	16QAM	64QAM	256QAM	
Middle CH	5.10	5.08	5.12	5.21		10.21	10.39	10.25	10.11	
BW	15M					20M				
Mod.	QPSK	16QAM	64QAM	256QAM		QPSK	16QAM	64QAM	256QAM	
Middle CH	14.57	14.48	14.30	14.57		19.70	19.82	19.86	19.74	



FR1 n5 / 5MHz / CP OFDM

QPSK

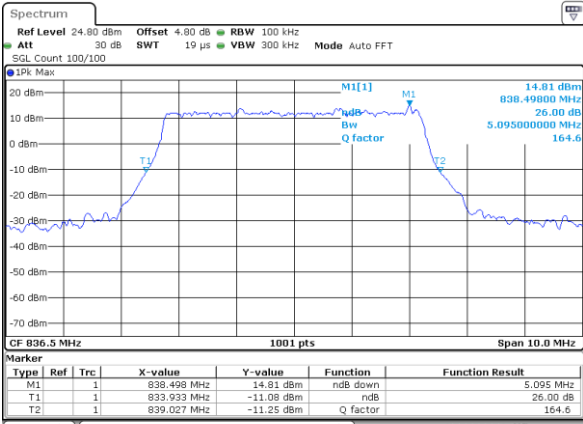

Date: 9,SEP,2022 03:58:31

16QAM

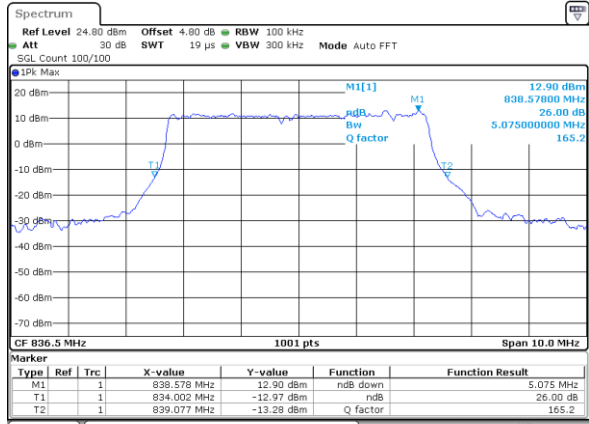

Date: 9,SEP,2022 03:59:12

64QAM

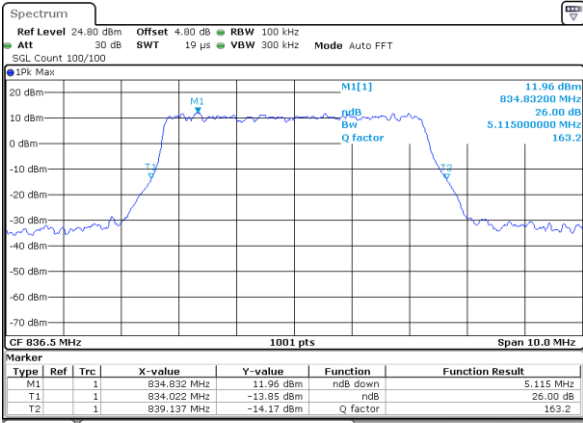

Date: 9,SEP,2022 03:59:53

256QAM

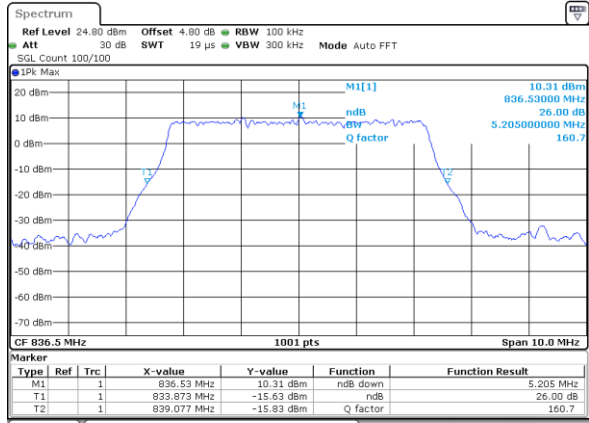

Date: 9,SEP,2022 04:00:29



FR1 n5 / 10MHz / CP OFDM

QPSK

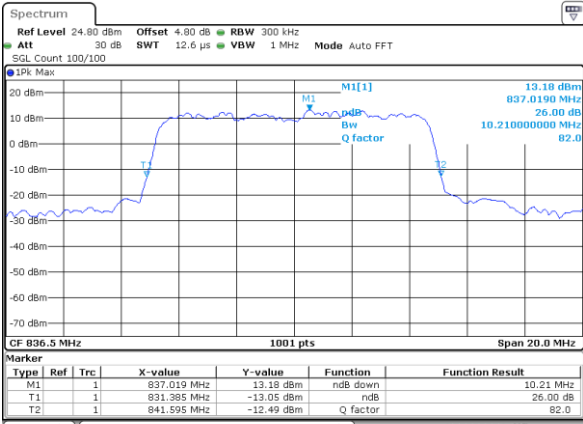

Date: 9,SEP,2022 03:44:10

16QAM

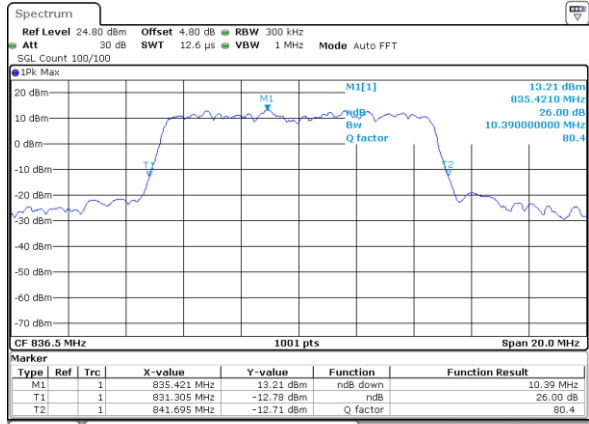

Date: 9,SEP,2022 03:43:47

64QAM

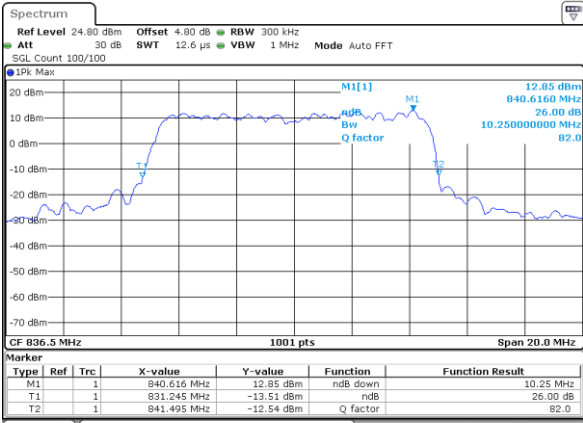

Date: 9,SEP,2022 03:43:28

256QAM

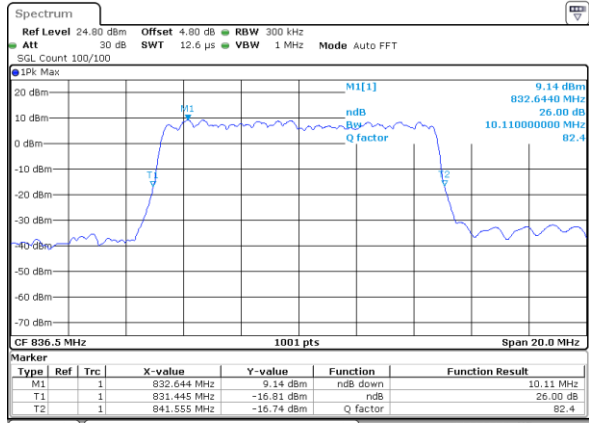

Date: 9,SEP,2022 03:43:07



FR1 n5 / 15MHz / CP OFDM

QPSK

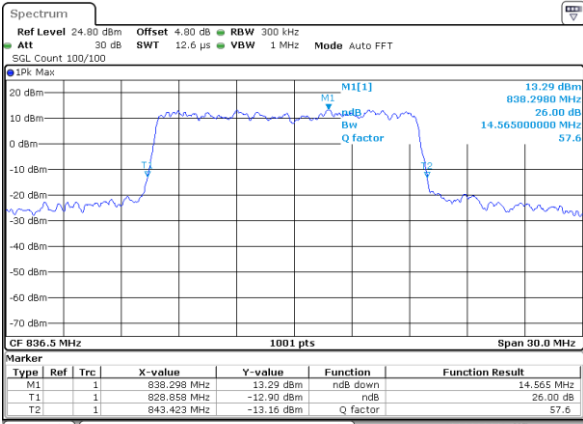

Date: 9,SEP,2022 03:35:03

16QAM

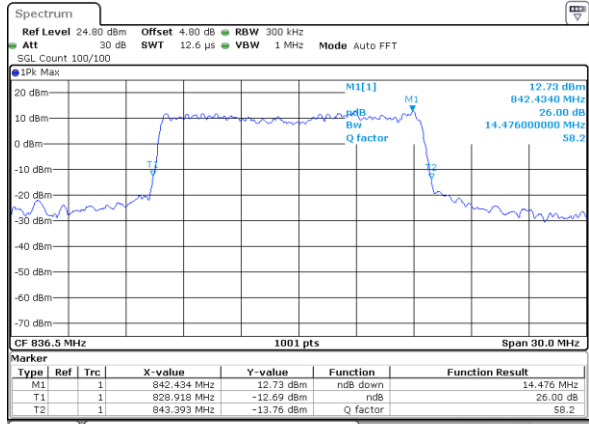

Date: 9,SEP,2022 03:39:28

64QAM

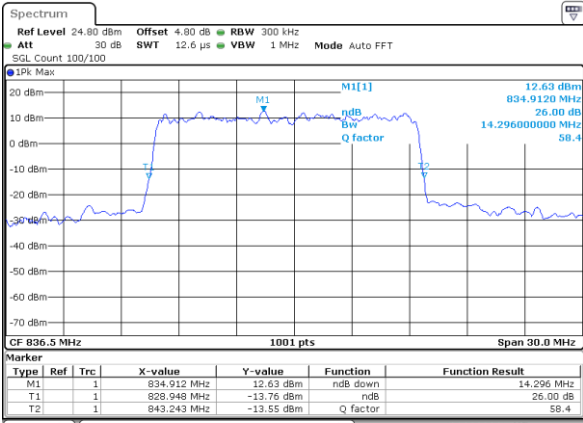

Date: 9,SEP,2022 03:39:48

256QAM

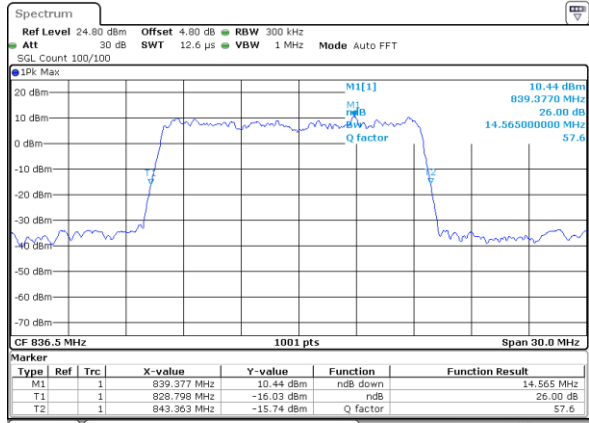

Date: 9,SEP,2022 03:40:33