



FCC TEST REPORT

REPORT NO.: RF980702L14

MODEL NO.: SJYN0127A
(Refer to item 3.1 for more detail)

RECEIVED: Jul. 21, 2009

TESTED: Jul. 27 ~ Aug. 03, 2009

ISSUED: Aug. 05, 2009

APPLICANT: Motorola, Inc.

ADDRESS: 600 NORTH US HIGHWAY 45 LIBERTYVILLE, IL
60048

ISSUED BY: Bureau Veritas Consumer Products Services (H.K.)
Ltd., Taoyuan Branch

LAB ADDRESS: No. 47, 14th Ling, Chia Pau Tsuen, Lin Kou Hsiang,
Taipei Hsien 244, Taiwan, R.O.C.

TEST LOCATION: No. 19, Hwa Ya 2nd Rd, Wen Hwa Tsuen, Kwei
Shan Hsiang, Taoyuan Hsien 333, Taiwan, R.O.C.

This test report consists of 41 pages in total. It may be duplicated completely for legal use with the approval of the applicant. It should not be reproduced except in full, without the written approval of our laboratory. The client should not use it to claim product endorsement by TAF or any government agencies. The test results in the report only apply to the tested sample.





TABLE OF CONTENTS

1.	CERTIFICATION	3
2.	SUMMARY OF TEST RESULTS	4
2.1	MEASUREMENT UNCERTAINTY	4
3.	GENERAL INFORMATION.....	5
3.1.	GENERAL DESCRIPTION OF EUT	5
3.2.	DESCRIPTION OF TEST MODES.....	6
3.2.1.	CONFIGURATION OF SYSTEM UNDER TEST	6
3.2.2.	TEST MODE APPLICABILITY AND TESTED CHANNEL DETAIL	7
3.2.3.	GENERAL DESCRIPTION OF APPLIED STANDARDS	8
3.2.4.	DESCRIPTION OF SUPPORT UNITS	8
4.	TEST TYPES AND RESULTS	9
4.1.	CONDUCTED EMISSION MEASUREMENT	9
4.2.	RADIATED EMISSION MEASUREMENT	9
4.2.1.	LIMITS OF RADIATED EMISSION MEASUREMENT.....	9
4.2.2.	TEST INSTRUMENTS	10
4.2.3.	TEST PROCEDURES	11
4.2.4.	DEVIATION FROM TEST STANDARD	11
4.2.5.	TEST SETUP	12
4.2.6.	EUT OPERATING CONDITIONS	12
4.2.7.	TEST RESULTS	13
4.3.	EMISSION BAND MEASUREMENT	31
4.3.1.	LIMITS OF EMISSION BAND MEASUREMENT	31
4.3.2.	TEST INSTRUMENTS	31
4.3.3.	TEST PROCEDURES	31
4.3.4.	DEVIATION FROM TEST STANDARD	32
4.3.5.	TEST SETUP	32
4.3.6.	EUT OPERATING CONDITIONS	32
4.3.7.	TEST RESULTS	33
5.	PHOTOGRAPHS OF THE TEST CONFIGURATION.....	39
6.	INFORMATION ON THE TESTING LABORATORIES	40
7.	APPENDIX A – MODIFICATIONS RECORDERS FOR ENGINEERING CHANGES TO THE EUT BY THE LAB.....	41



1. CERTIFICATION

PRODUCT: GPS Navigation Device Cradle
MODEL NO.: SJYN0127A (Refer to item 3.1 for more detail)
BRAND NAME: Motorola
APPLICANT: Motorola, Inc.
TESTED: Jul. 27 ~ Aug. 03, 2009
TEST SAMPLE: ENGINEERING SAMPLE
STANDARDS: **FCC Part 15, Subpart C (Section 15.239)**
ANSI C63.4-2003

The above equipment (model: SJYN0127A, SJYN0126A) have been tested by **Bureau Veritas Consumer Products Services (H.K.) Ltd., Taoyuan Branch**, and found compliance with the requirement of the above standards. The test record, data evaluation & Equipment Under Test (EUT) configurations represented herein are true and accurate accounts of the measurements of the sample's EMC characteristics under the conditions specified in this report.

PREPARED BY : Andrea Hsia , **DATE:** Aug. 05, 2009
Andrea Hsia / Specialist

TECHNICAL ACCEPTANCE : Long Chen , **DATE:** Aug. 05, 2009
Responsible for RF Long Chen / Senior Engineer

APPROVED BY : Gary Chang , **DATE:** Aug. 05, 2009
Gary Chang / Assistant Manager

2. SUMMARY OF TEST RESULTS

The EUT has been tested according to the following specifications:

APPLIED STANDARD: FCC Part 15, Subpart C			
STANDARD SECTION	TEST TYPE	RESULT	REMARK
15.207	AC Power Conducted Emission	NA	Power supply is 5.4Vdc from car charger
15.239, 15.209	Radiated Emission Test	PASS	Meet the requirement of limit. Minimum passing margin is -1.43dB at 88.10MHz.

2.1 MEASUREMENT UNCERTAINTY

Where relevant, the following measurement uncertainty levels have been estimated for tests performed on the EUT as specified in CISPR 16-4-2:

MEASUREMENT	FREQUENCY	UNCERTAINTY
Radiated emissions	30MHz ~ 200MHz	2.93 dB
	200MHz ~1000MHz	2.95 dB
	1GHz ~ 18GHz	2.26 dB
	18GHz ~ 40GHz	1.94 dB

This uncertainty represents an expanded uncertainty expressed at approximately the 95% confidence level using a coverage factor of k=2.

3. GENERAL INFORMATION

3.1. GENERAL DESCRIPTION OF EUT

EUT	GPS Navigation Device Cradle
MODEL NO.	SJYN0127A (Refer to note for more detail)
FCC ID	IHDP6KK1
POWER SUPPLY	5.4Vdc from car charger
MODULATION TYPE	FM
FREQUENCY RANGE	88.1~107.9MHz
NUMBER OF CHANNEL	199
CHANNEL SPACING	100kHz
ANTENNA TYPE	monopole antenna
DATA CABLE	NA
I/O PORTS	Refer to user's manual
ACCESSORY DEVICES	Car Charger

NOTE:

- For Cradle functions and models listed as below:

BRAND	MODEL	FCC ID	DIFFERENCE
Motorola	SJYN0127A	IHDP6KK1	DR Cradle: FM RDS/TMC (FM Rx) + FM TX + DR sensors
Motorola	SJYN0126A	IHDP6KK1	Music Cradle: FM RDS/TMC (FM Rx) + FM TX

**only TX function had been tested and record in the test report.

***Cradle can not be work alone.

- A set of the EUT include GPS Navigation Device and Cradle. This report covers Cradle FM TX only. The GPS Navigation Device data is performed in following test report.

BRAND	MODEL	REMARK
Motorola	GC450	With Music cradle, Traffic Cradle & Power Cradle
Motorola	GC550	With DR cradle, Music Cradle & Traffic Cradle

- The EUT was powered by the following car charger:

BRAND	MOTOROLA
MODEL	SPN5579A
INPUT POWER	10.8 ~ 33Vdc, 0-1.2A
OUTPUT POWER	5.4Vdc, 1.8A
POWER LINE	1.5m non-shielded cable without core

- The following accessories are for support units only.

PRODUCT	DESCRIPTION
SD Card	-
USB cable	0.9m shielded cable without core

- The above EUT information was declared by manufacturer and for more detailed features description, please refer to the manufacturer's specifications or User's Manual.

3.2. DESCRIPTION OF TEST MODES

The tuning range has been manually verified and the device can work only within 88.1 ~ 107.9MHz band.

Three channels were provided to this EUT.

CHANNEL	FREQUENCY (MHz)
Low channel (L)	88.1MHz
Middle channel (M)	98.0MHz
High channel (H)	107.9MHz

3.2.1. CONFIGURATION OF SYSTEM UNDER TEST

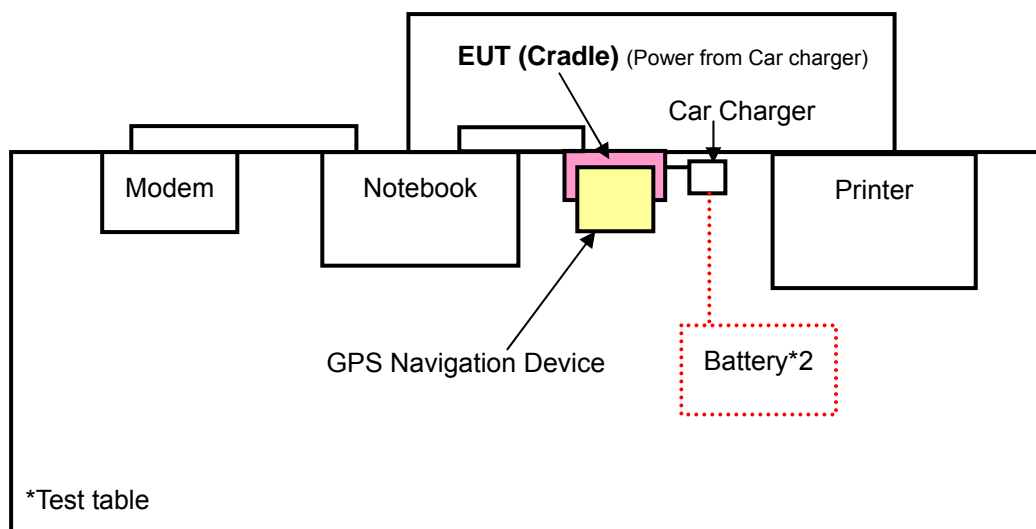

3.2.2. TEST MODE APPLICABILITY AND TESTED CHANNEL DETAIL

EUT CONFIGURE MODE	Applicable to			Description
	PLC	RE<1G	EB	
A	NOTE	√	√	DR Cradle+ GPS Navigation Device model: GC550
B	NOTE	√	√	Music Cradle+ GPS Navigation Device model: GC550
C	NOTE	√	√	Music Cradle+ GPS Navigation Device model: GC450

Where **PLC**: Power Line Conducted Emission **RE<1G**: Radiated Emission below 1GHz
EB: Emission Band Measurement

NOTE: No need to concern of Conducted Emission due to the EUT is powered by car charger.

RADIATED EMISSION TEST (BELOW 1 GHz):

- Pre-Scan has been conducted to determine the worst-case mode from all possible combinations between available modulations and XYZ Axis.
- Following channel(s) was (were) selected for the final test as listed below.

EUT CONFIGURE MODE	TESTED CHANNEL	MODULATION TYPE	AXIS
A	L, M, H	FM	Z
B	L, M, H	FM	Z
C	L, M, H	FM	Z

EMISSION BAND MEASUREMENT:

- Following channel(s) was (were) selected for the final test as listed below.

EUT CONFIGURE MODE	TESTED CHANNEL	MODULATION TYPE
A	L, M, H	FM
B	L, M, H	FM
C	L, M, H	FM

3.2.3. GENERAL DESCRIPTION OF APPLIED STANDARDS

The EUT is the transmitter part of a FM transmitter. According to the specifications of the manufacturer, it must comply with the requirements of the following standards:

FCC Part 15, Subpart C (15.239)

ANSI C63.4- 2003

All test items have been performed and recorded as per the above standards.

NOTE: The EUT is also considered as a kind of computer peripheral, because the connection to computer is necessary for typical use. It has been verified to comply with the requirements of FCC Part 15, Subpart B, Class B (DoC). The test report has been issued separately.

3.2.4. DESCRIPTION OF SUPPORT UNITS

The EUT has been tested as an independent unit together with other necessary accessories or support units. The following support units or accessories were used to form a representative test configuration during the tests.

NO.	PRODUCT	BRAND	MODEL NO.	SERIAL NO.	FCC ID
1	NOTEBOOK	DELL	PP05L	12130898320	E2K24CLNS
2	MODEM	ACEEX	1414V/3	0401008253	IFAXDM1414
3	PRINTER	EPSON	LQ-300+	DCGY046016	FCC DoC Approved
4	BATTERY	YUASA	80D26R	NA	NA

NO.	SIGNAL CABLE DESCRIPTION OF THE ABOVE SUPPORT UNITS
1	NA
2	1.2m braid shielded wire, DB25 & DB9 connector, w/o core.
3	1.8m braid shielded wire, DB25 connector, w/o core.
4	NA

NOTE: All power cords of the above support units are non shielded (1.8m).

4. TEST TYPES AND RESULTS

4.1. CONDUCTED EMISSION MEASUREMENT

NA

4.2. RADIATED EMISSION MEASUREMENT

4.2.1. LIMITS OF RADIATED EMISSION MEASUREMENT

According to 15.239 the field strength of Emissions from intentional radiators operated under these frequencies bands shall not exceed the following:

Fundamental frequency (MHz)	Field strength of fundamental (dBuV/m)	
	Peak	Average
88 to 108	67.96	47.96

Field strength limits are at the distance of 3 meters, Emissions radiated outside of the specified bands, shall be according to the general radiated limits in 15.209 as following:

Frequencies (MHz)	Field strength (microvolts/meter)	Measurement distance (meters)
0.009-0.490	2400/F(kHz)	300
0.490-1.705	24000/F(kHz)	30
1.705-30.0	30	30
30-88	100	3
88-216	150	3
216-960	200	3
Above 960	500	3

As shown in 15.35(b), for frequencies above 1000MHz, the field strength limits are based on average detector, however, the peak field strength of any emission shall not exceed the maximum permitted average limits, specified above by more than 20dB under any condition of modulation.



4.2.2. TEST INSTRUMENTS

DESCRIPTION & MANUFACTURER	MODEL NO.	SERIAL NO.	DATE OF CALIBRATION	DUE DATE OF CALIBRATION
Test Receiver ROHDE & SCHWARZ	ESIB7	100212	May 25, 2009	May 24, 2010
Spectrum Analyzer ROHDE & SCHWARZ	FSP40	100269	Aug. 08, 2008	Aug. 07, 2009
BILOG Antenna SCHWARZBECK	VULB9168	9168-156	Apr. 30, 2009	Apr. 29, 2010
HORN Antenna SCHWARZBECK	BBHA 9120 D	9120D-563	Aug. 06, 2008	Aug. 05, 2009
HORN Antenna SCHWARZBECK	BBHA 9170	BBHA9170242	Jan. 06, 2009	Jan. 05, 2010
Preamplifier Agilent	8449B	3008A01911	Sep. 10, 2008	Sep. 09, 2009
Preamplifier Agilent	8447D	2944A10638	Dec. 26, 2008	Dec. 25, 2009
RF signal cable HUBER+SUHNNER	SUCOFLEX 104	218190/4 231241/4	May 13, 2009	May 12, 2010
RF signal cable Worken	8D-FB	Cable-HYCH9-01	Aug. 09, 2008	Aug. 08, 2009
Software	ADT_Radiated_ V7.6.15.9.2	NA	NA	NA
Antenna Tower EMCO	2070/2080	512.835.4684	NA	NA
Turn Table EMCO	2087-2.03	NA	NA	NA
Antenna Tower & Turn Table Controller EMCO	2090	NA	NA	NA

- NOTE:**
1. The calibration interval of the above test instruments is 12 months and the calibrations are traceable to NML/ROC and NIST/USA.
 2. The test was performed in HwaYa Chamber 9.
 3. The horn antenna and HP preamplifier (model: 8449B) are used only for the measurement of emission frequency above 1GHz if tested.
 4. The FCC Site Registration No. is 460141.
 5. The IC Site Registration No. is IC 7450F-4.

4.2.3. TEST PROCEDURES

- a. The EUT was placed on the top of a rotating table 0.8 meters above the ground at a 3 meter semi-anechoic chamber. The table was rotated 360 degrees to determine the position of the highest radiation.
- b. The EUT was set 3 meters away from the interference-receiving antenna, which was mounted on the top of a variable-height antenna tower.
- c. The antenna is a broadband antenna, and its height is varied from one meter to four meters above the ground to determine the maximum value of the field strength. Both horizontal and vertical polarizations of the antenna are set to make the measurement.
- d. For each suspected emission, the EUT was arranged to its worst case and then the antenna was tuned to heights from 1 meter to 4 meters and the rotatable table was turned from 0 degrees to 360 degrees to find the maximum reading.
- e. The test-receiver system was set to Peak Detect Function and Specified Bandwidth with Maximum Hold Mode.
- f. If the emission level of the EUT in peak mode was lower than the limit specified, then testing could be stopped and the peak values of the EUT would be reported. Otherwise the emissions would be re-tested one by one using peak, quasi-peak method or average method as specified and then reported in data sheet.

NOTE:

1. The resolution bandwidth and video bandwidth of test receiver/spectrum analyzer is 120kHz for Quasi-peak detection at frequency below 1GHz
2. The resolution bandwidth and video bandwidth of test receiver/spectrum analyzer is 1 MHz for Peak detection (PK) at frequency above 1GHz.

4.2.4. DEVIATION FROM TEST STANDARD

No deviation.

4.2.5. TEST SETUP

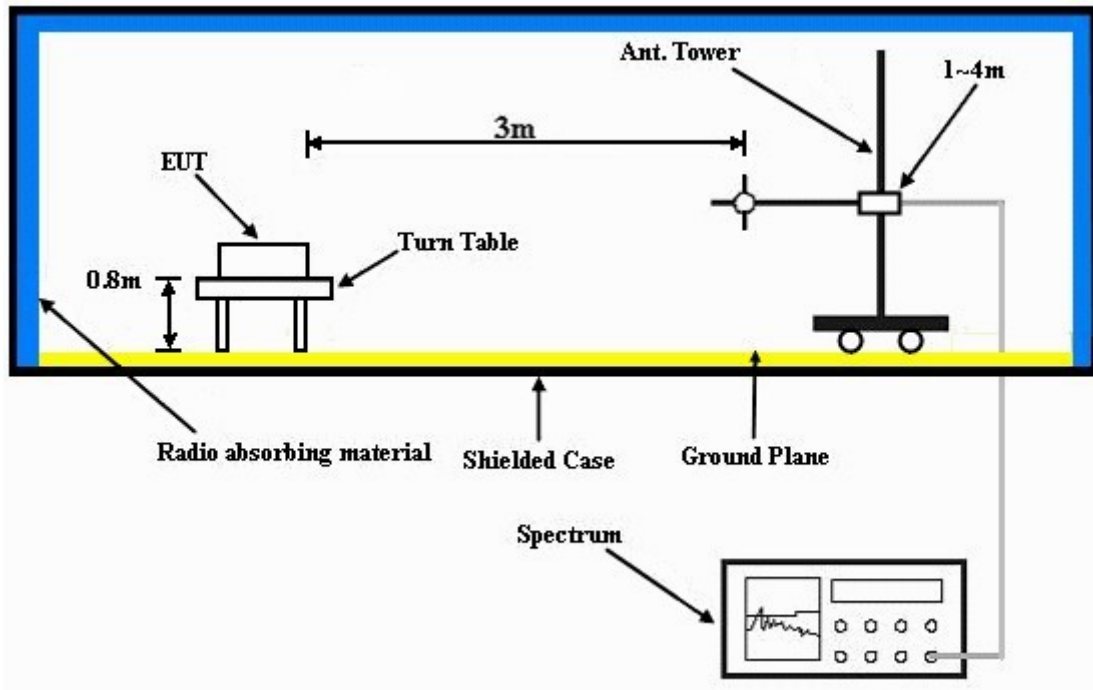

For the actual test configuration, please refer to the attached file (Test Setup Photo).

4.2.6. EUT OPERATING CONDITIONS

- a. GC550 and GC450 play an mp3 file and send the music out through EUT.
- b. Volume of GC550 AND GC450 is tuned to max setting.

4.2.7. TEST RESULTS

EUT TEST CONDITION		MEASUREMENT DETAIL	
CHANNEL	Low Channel	FREQUENCY RANGE	87 ~ 109MHz
MODULATION TYPE	FM	DETECTOR FUNCTION	Peak (PK) Average (AV)
INPUT POWER (SYSTEM)	120Vac, 60 Hz	ENVIRONMENTAL CONDITIONS	23deg. C, 68%RH, 1026hPa
TEST MODE	A	TESTED BY	Lori Chiu

ANTENNA POLARITY & TEST DISTANCE: HORIZONTAL AT 3 m								
No.	Freq. (MHz)	Emission Level (dBuV/m)	Limit (dBuV/m)	Margin (dB)	Antenna Height (m)	Table Angle (Degree)	Raw Value (dBuV)	Correction Factor (dB/m)
1	*88.10	46.95 PK	67.96	-21.01	1.60 H	111	37.95	9.00
2	*88.10	46.53 AV	47.96	-1.43	1.60 H	111	37.53	9.00

ANTENNA POLARITY & TEST DISTANCE: VERTICAL AT 3 m								
No.	Freq. (MHz)	Emission Level (dBuV/m)	Limit (dBuV/m)	Margin (dB)	Antenna Height (m)	Table Angle (Degree)	Raw Value (dBuV)	Correction Factor (dB/m)
1	*88.10	45.36 PK	67.96	-22.60	1.42 V	129	36.36	9.00
2	*88.10	44.58 AV	47.96	-3.68	1.42 V	129	35.58	9.00

- REMARKS:**
1. Emission level (dBuV/m) = Raw Value (dBuV) + Correction Factor (dB/m).
 2. Correction Factor (dB/m) = Antenna Factor (dB/m) + Cable Factor (dB).
 3. The other emission levels were very low against the limit.
 4. Margin value = Emission level – Limit value.
 5. “ * “ : Fundamental frequency.

EUT TEST CONDITION		MEASUREMENT DETAIL	
CHANNEL	Middle Channel	FREQUENCY RANGE	87 ~ 109MHz
MODULATION TYPE	FM	DETECTOR FUNCTION	Peak (PK) Average (AV)
INPUT POWER (SYSTEM)	120Vac, 60 Hz	ENVIRONMENTAL CONDITIONS	23deg. C, 68%RH, 1026hPa
TEST MODE	A	TESTED BY	Lori Chiu

ANTENNA POLARITY & TEST DISTANCE: HORIZONTAL AT 3 m								
No.	Freq. (MHz)	Emission Level (dBuV/m)	Limit (dBuV/m)	Margin (dB)	Antenna Height (m)	Table Angle (Degree)	Raw Value (dBuV)	Correction Factor (dB/m)
1	*98.00	46.88 PK	67.96	-21.08	1.17 H	143	37.57	9.31
2	*98.00	46.04 AV	47.96	-1.92	1.17 H	143	36.73	9.31

ANTENNA POLARITY & TEST DISTANCE: VERTICAL AT 3 m								
No.	Freq. (MHz)	Emission Level (dBuV/m)	Limit (dBuV/m)	Margin (dB)	Antenna Height (m)	Table Angle (Degree)	Raw Value (dBuV)	Correction Factor (dB/m)
1	*98.00	44.37 PK	67.96	-23.59	2.00 V	321	35.06	9.31
2	*98.00	43.25 AV	47.96	-4.71	2.00 V	321	33.94	9.31

- REMARKS:**
1. Emission level (dBuV/m) = Raw Value (dBuV) + Correction Factor (dB/m).
 2. Correction Factor (dB/m) = Antenna Factor (dB/m) + Cable Factor (dB).
 3. The other emission levels were very low against the limit.
 4. Margin value = Emission level – Limit value.
 5. “ * “ : Fundamental frequency.

EUT TEST CONDITION		MEASUREMENT DETAIL	
CHANNEL	High Channel	FREQUENCY RANGE	87 ~ 109MHz
MODULATION TYPE	FM	DETECTOR FUNCTION	Peak (PK) Average (AV)
INPUT POWER (SYSTEM)	120Vac, 60 Hz	ENVIRONMENTAL CONDITIONS	23deg. C, 68%RH, 1026hPa
TEST MODE	A	TESTED BY	Lori Chiu

ANTENNA POLARITY & TEST DISTANCE: HORIZONTAL AT 3 m								
No.	Freq. (MHz)	Emission Level (dBuV/m)	Limit (dBuV/m)	Margin (dB)	Antenna Height (m)	Table Angle (Degree)	Raw Value (dBuV)	Correction Factor (dB/m)
1	*107.90	46.99 PK	67.96	-20.97	1.53 H	0	36.70	10.29
2	*107.90	46.29 AV	47.96	-1.67	1.53 H	0	36.00	10.29

ANTENNA POLARITY & TEST DISTANCE: VERTICAL AT 3 m								
No.	Freq. (MHz)	Emission Level (dBuV/m)	Limit (dBuV/m)	Margin (dB)	Antenna Height (m)	Table Angle (Degree)	Raw Value (dBuV)	Correction Factor (dB/m)
1	*107.90	44.05 PK	67.96	-23.91	1.00 V	14	33.76	10.29
2	*107.90	43.13 AV	47.96	-4.83	1.00 V	14	32.84	10.29

- REMARKS:**
1. Emission level (dBuV/m) = Raw Value (dBuV) + Correction Factor (dB/m).
 2. Correction Factor (dB/m) = Antenna Factor (dB/m) + Cable Factor (dB).
 3. The other emission levels were very low against the limit.
 4. Margin value = Emission level – Limit value.
 5. “ * “ : Fundamental frequency.



A D T

EUT TEST CONDITION		MEASUREMENT DETAIL	
CHANNEL	Low Channel	FREQUENCY RANGE	87 ~ 109MHz
MODULATION TYPE	FM	DETECTOR FUNCTION	Peak (PK) Average (AV)
INPUT POWER (SYSTEM)	120Vac, 60 Hz	ENVIRONMENTAL CONDITIONS	23deg. C, 68%RH, 1026hPa
TEST MODE	B	TESTED BY	Match Tsui

ANTENNA POLARITY & TEST DISTANCE: HORIZONTAL AT 3 m								
No.	Freq. (MHz)	Emission Level (dBuV/m)	Limit (dBuV/m)	Margin (dB)	Antenna Height (m)	Table Angle (Degree)	Raw Value (dBuV)	Correction Factor (dB/m)
1	*88.10	46.03 PK	67.96	-21.93	2.30 H	346	37.03	9.00
2	*88.10	45.26 AV	47.96	-2.70	2.30 H	346	36.26	9.00

ANTENNA POLARITY & TEST DISTANCE: VERTICAL AT 3 m								
No.	Freq. (MHz)	Emission Level (dBuV/m)	Limit (dBuV/m)	Margin (dB)	Antenna Height (m)	Table Angle (Degree)	Raw Value (dBuV)	Correction Factor (dB/m)
1	*88.10	47.09 PK	67.96	-20.87	1.01 V	233	38.09	9.00
2	*88.10	46.41 AV	47.96	-1.55	1.01 V	233	37.41	9.00

- REMARKS:**
1. Emission level (dBuV/m) = Raw Value (dBuV) + Correction Factor (dB/m).
 2. Correction Factor (dB/m) = Antenna Factor (dB/m) + Cable Factor (dB).
 3. The other emission levels were very low against the limit.
 4. Margin value = Emission level – Limit value.
 5. “ * “ : Fundamental frequency.



A D T

EUT TEST CONDITION		MEASUREMENT DETAIL	
CHANNEL	Middle Channel	FREQUENCY RANGE	87 ~ 109MHz
MODULATION TYPE	FM	DETECTOR FUNCTION	Peak (PK) Average (AV)
INPUT POWER (SYSTEM)	120Vac, 60 Hz	ENVIRONMENTAL CONDITIONS	23deg. C, 68%RH, 1026hPa
TEST MODE	B	TESTED BY	Match Tsui

ANTENNA POLARITY & TEST DISTANCE: HORIZONTAL AT 3 m								
No.	Freq. (MHz)	Emission Level (dBuV/m)	Limit (dBuV/m)	Margin (dB)	Antenna Height (m)	Table Angle (Degree)	Raw Value (dBuV)	Correction Factor (dB/m)
1	*98.00	46.27 PK	67.96	-21.69	1.99 H	355	36.96	9.31
2	*98.00	45.95 AV	47.96	-2.01	1.99 H	355	36.64	9.31

ANTENNA POLARITY & TEST DISTANCE: VERTICAL AT 3 m								
No.	Freq. (MHz)	Emission Level (dBuV/m)	Limit (dBuV/m)	Margin (dB)	Antenna Height (m)	Table Angle (Degree)	Raw Value (dBuV)	Correction Factor (dB/m)
1	*98.00	46.71 PK	67.96	-21.25	1.00 V	221	37.40	9.31
2	*98.00	46.38 AV	47.96	-1.58	1.00 V	221	37.07	9.31

- REMARKS:**
1. Emission level (dBuV/m) = Raw Value (dBuV) + Correction Factor (dB/m).
 2. Correction Factor (dB/m) = Antenna Factor (dB/m) + Cable Factor (dB).
 3. The other emission levels were very low against the limit.
 4. Margin value = Emission level – Limit value.
 5. “ * “ : Fundamental frequency.

EUT TEST CONDITION		MEASUREMENT DETAIL	
CHANNEL	High Channel	FREQUENCY RANGE	87 ~ 109MHz
MODULATION TYPE	FM	DETECTOR FUNCTION	Peak (PK) Average (AV)
INPUT POWER (SYSTEM)	120Vac, 60 Hz	ENVIRONMENTAL CONDITIONS	23deg. C, 68%RH, 1026hPa
TEST MODE	B	TESTED BY	Match Tsui

ANTENNA POLARITY & TEST DISTANCE: HORIZONTAL AT 3 m								
No.	Freq. (MHz)	Emission Level (dBuV/m)	Limit (dBuV/m)	Margin (dB)	Antenna Height (m)	Table Angle (Degree)	Raw Value (dBuV)	Correction Factor (dB/m)
1	*107.90	46.31 PK	67.96	-21.65	1.58 H	204	36.02	10.29
2	*107.90	45.78 AV	47.96	-2.18	1.58 H	204	35.49	10.29

ANTENNA POLARITY & TEST DISTANCE: VERTICAL AT 3 m								
No.	Freq. (MHz)	Emission Level (dBuV/m)	Limit (dBuV/m)	Margin (dB)	Antenna Height (m)	Table Angle (Degree)	Raw Value (dBuV)	Correction Factor (dB/m)
1	*107.90	46.76 PK	67.96	-21.20	1.12 V	0	36.47	10.29
2	*107.90	46.05 AV	47.96	-1.91	1.12 V	0	35.76	10.29

- REMARKS:**
1. Emission level (dBuV/m) = Raw Value (dBuV) + Correction Factor (dB/m).
 2. Correction Factor (dB/m) = Antenna Factor (dB/m) + Cable Factor (dB).
 3. The other emission levels were very low against the limit.
 4. Margin value = Emission level – Limit value.
 5. “ * “ : Fundamental frequency.



A D T

EUT TEST CONDITION		MEASUREMENT DETAIL	
CHANNEL	Low Channel	FREQUENCY RANGE	87 ~ 109MHz
MODULATION TYPE	FM	DETECTOR FUNCTION	Peak (PK) Average (AV)
INPUT POWER (SYSTEM)	120Vac, 60 Hz	ENVIRONMENTAL CONDITIONS	23deg. C, 68%RH, 1026hPa
TEST MODE	C	TESTED BY	Match Tsui

ANTENNA POLARITY & TEST DISTANCE: HORIZONTAL AT 3 m								
No.	Freq. (MHz)	Emission Level (dBuV/m)	Limit (dBuV/m)	Margin (dB)	Antenna Height (m)	Table Angle (Degree)	Raw Value (dBuV)	Correction Factor (dB/m)
1	*88.10	42.73 PK	67.96	-25.23	2.26 H	151	33.73	9.00
2	*88.10	41.85 AV	47.96	-6.11	2.26 H	151	32.85	9.00

ANTENNA POLARITY & TEST DISTANCE: VERTICAL AT 3 m								
No.	Freq. (MHz)	Emission Level (dBuV/m)	Limit (dBuV/m)	Margin (dB)	Antenna Height (m)	Table Angle (Degree)	Raw Value (dBuV)	Correction Factor (dB/m)
1	*88.10	46.97 PK	67.96	-20.99	1.11 V	53	37.97	9.00
2	*88.10	46.00 AV	47.96	-1.96	1.11 V	53	37.00	9.00

- REMARKS:**
1. Emission level (dBuV/m) = Raw Value (dBuV) + Correction Factor (dB/m).
 2. Correction Factor (dB/m) = Antenna Factor (dB/m) + Cable Factor (dB).
 3. The other emission levels were very low against the limit.
 4. Margin value = Emission level – Limit value.
 5. “ * “ : Fundamental frequency.



A D T

EUT TEST CONDITION		MEASUREMENT DETAIL	
CHANNEL	Middle Channel	FREQUENCY RANGE	87 ~ 109MHz
MODULATION TYPE	FM	DETECTOR FUNCTION	Peak (PK) Average (AV)
INPUT POWER (SYSTEM)	120Vac, 60 Hz	ENVIRONMENTAL CONDITIONS	23deg. C, 68%RH, 1026hPa
TEST MODE	C	TESTED BY	Match Tsui

ANTENNA POLARITY & TEST DISTANCE: HORIZONTAL AT 3 m								
No.	Freq. (MHz)	Emission Level (dBuV/m)	Limit (dBuV/m)	Margin (dB)	Antenna Height (m)	Table Angle (Degree)	Raw Value (dBuV)	Correction Factor (dB/m)
1	*98.00	42.27 PK	67.96	-25.49	1.98 H	360	33.16	9.31
2	*98.00	41.21 AV	47.96	-6.75	1.98 H	360	31.90	9.31

ANTENNA POLARITY & TEST DISTANCE: VERTICAL AT 3 m								
No.	Freq. (MHz)	Emission Level (dBuV/m)	Limit (dBuV/m)	Margin (dB)	Antenna Height (m)	Table Angle (Degree)	Raw Value (dBuV)	Correction Factor (dB/m)
1	*98.00	47.00 PK	67.96	-20.96	1.14 V	19	37.69	9.31
2	*98.00	45.94 AV	47.96	-2.02	1.14 V	19	36.63	9.31

- REMARKS:**
1. Emission level (dBuV/m) = Raw Value (dBuV) + Correction Factor (dB/m).
 2. Correction Factor (dB/m) = Antenna Factor (dB/m) + Cable Factor (dB).
 3. The other emission levels were very low against the limit.
 4. Margin value = Emission level – Limit value.
 5. “ * “ : Fundamental frequency.



A D T

EUT TEST CONDITION		MEASUREMENT DETAIL	
CHANNEL	High Channel	FREQUENCY RANGE	87 ~ 109MHz
MODULATION TYPE	FM	DETECTOR FUNCTION	Peak (PK) Average (AV)
INPUT POWER (SYSTEM)	120Vac, 60 Hz	ENVIRONMENTAL CONDITIONS	23deg. C, 68%RH, 1026hPa
TEST MODE	C	TESTED BY	Match Tsui

ANTENNA POLARITY & TEST DISTANCE: HORIZONTAL AT 3 m								
No.	Freq. (MHz)	Emission Level (dBuV/m)	Limit (dBuV/m)	Margin (dB)	Antenna Height (m)	Table Angle (Degree)	Raw Value (dBuV)	Correction Factor (dB/m)
1	*107.90	41.06 PK	67.96	-26.90	1.54 H	237	30.77	10.29
2	*107.90	40.48 AV	47.96	-7.48	1.54 H	237	30.19	10.29

ANTENNA POLARITY & TEST DISTANCE: VERTICAL AT 3 m								
No.	Freq. (MHz)	Emission Level (dBuV/m)	Limit (dBuV/m)	Margin (dB)	Antenna Height (m)	Table Angle (Degree)	Raw Value (dBuV)	Correction Factor (dB/m)
1	*107.90	46.23 PK	67.96	-21.73	1.09 V	164	35.94	10.29
2	*107.90	45.54 AV	47.96	-2.42	1.09 V	164	35.25	10.29

- REMARKS:**
1. Emission level (dBuV/m) = Raw Value (dBuV) + Correction Factor (dB/m).
 2. Correction Factor (dB/m) = Antenna Factor (dB/m) + Cable Factor (dB).
 3. The other emission levels were very low against the limit.
 4. Margin value = Emission level – Limit value.
 5. “ * “ : Fundamental frequency.



A D T

EUT TEST CONDITION		MEASUREMENT DETAIL	
CHANNEL	Low Channel	FREQUENCY RANGE	Below 1000MHz
MODULATION TYPE	FM	DETECTOR FUNCTION	Quasi-Peak
INPUT POWER (SYSTEM)	120Vac, 60 Hz	ENVIRONMENTAL CONDITIONS	23deg. C, 68%RH, 10262hPa
TEST MODE	A	TESTED BY	Lori Chiu

ANTENNA POLARITY & TEST DISTANCE: HORIZONTAL AT 3 M								
No.	Freq. (MHz)	Emission Level (dBuV/m)	Limit (dBuV/m)	Margin (dB)	Antenna Height (m)	Table Angle (Degree)	Raw Value (dBuV)	Correction Factor (dB/m)
1	125.17	38.94 QP	43.50	-4.56	1.50 H	115	26.99	11.95
2	154.33	38.33 QP	43.50	-5.17	2.00 H	70	24.51	13.82
3	206.83	37.72 QP	43.50	-5.78	1.25 H	148	26.82	10.90
4	230.77	43.43 QP	46.00	-2.57	1.42 H	310	31.46	11.97
5	300.16	39.27 QP	46.00	-6.73	1.25 H	64	25.59	13.67
6	731.79	37.77 QP	46.00	-8.23	1.50 H	232	14.27	23.50
7	790.12	43.69 QP	46.00	-2.31	1.25 H	10	18.64	25.05
8	860.11	40.13 QP	46.00	-5.87	1.00 H	37	14.40	25.73
ANTENNA POLARITY & TEST DISTANCE: VERTICAL AT 3 M								
No.	Freq. (MHz)	Emission Level (dBuV/m)	Limit (dBuV/m)	Margin (dB)	Antenna Height (m)	Table Angle (Degree)	Raw Value (dBuV)	Correction Factor (dB/m)
1	94.06	37.25 QP	43.50	-6.25	1.00 V	103	27.98	9.26
2	160.17	34.34 QP	43.50	-9.16	1.50 V	184	20.64	13.70
3	181.07	37.49 QP	43.50	-6.01	1.25 V	187	25.37	12.11
4	230.16	39.13 QP	46.00	-6.87	1.00 V	337	27.19	11.94
5	729.84	38.74 QP	46.00	-7.26	1.00 V	118	15.28	23.46
6	776.51	38.74 QP	46.00	-7.26	1.00 V	70	14.06	24.67

- REMARKS:**
1. Emission level(dBuV/m)=Raw Value(dBuV) + Correction Factor(dB/m)
 2. Correction Factor(dB/m) = Antenna Factor (dB/m) + Cable Factor (dB)
 3. The other emission levels were very low against the limit.
 4. Margin value = Emission level – Limit value.



A D T

EUT TEST CONDITION		MEASUREMENT DETAIL	
CHANNEL	Middle Channel	FREQUENCY RANGE	Below 1000MHz
MODULATION TYPE	FM	DETECTOR FUNCTION	Quasi-Peak
INPUT POWER (SYSTEM)	120Vac, 60 Hz	ENVIRONMENTAL CONDITIONS	23deg. C, 68%RH, 10262hPa
TEST MODE	A	TESTED BY	Lori Chiu

ANTENNA POLARITY & TEST DISTANCE: HORIZONTAL AT 3 M								
No.	Freq. (MHz)	Emission Level (dBuV/m)	Limit (dBuV/m)	Margin (dB)	Antenna Height (m)	Table Angle (Degree)	Raw Value (dBuV)	Correction Factor (dB/m)
1	154.33	38.14 QP	43.50	-5.36	2.00 H	97	24.32	13.82
2	183.50	37.91 QP	43.50	-5.59	2.00 H	103	25.99	11.92
3	206.83	37.49 QP	43.50	-6.01	1.25 H	145	26.59	10.90
4	230.16	42.72 QP	46.00	-3.28	1.50 H	301	30.78	11.94
5	776.51	39.27 QP	46.00	-6.73	1.00 H	10	14.59	24.67
6	860.11	39.41 QP	46.00	-6.59	1.00 H	49	13.68	25.73
ANTENNA POLARITY & TEST DISTANCE: VERTICAL AT 3 M								
No.	Freq. (MHz)	Emission Level (dBuV/m)	Limit (dBuV/m)	Margin (dB)	Antenna Height (m)	Table Angle (Degree)	Raw Value (dBuV)	Correction Factor (dB/m)
1	94.06	36.76 QP	43.50	-6.74	1.25 V	82	27.49	9.26
2	183.50	39.30 QP	43.50	-4.20	1.50 V	184	27.38	11.92
3	230.16	39.68 QP	46.00	-6.32	1.00 V	325	27.74	11.94
4	729.84	39.66 QP	46.00	-6.34	1.00 V	115	16.20	23.46
5	776.51	39.24 QP	46.00	-6.76	1.00 V	76	14.57	24.67
6	943.72	39.19 QP	46.00	-6.81	1.00 V	163	12.75	26.44

- REMARKS:**
1. Emission level(dBuV/m)=Raw Value(dBuV) + Correction Factor(dB/m)
 2. Correction Factor(dB/m) = Antenna Factor (dB/m) + Cable Factor (dB)
 3. The other emission levels were very low against the limit.
 4. Margin value = Emission level – Limit value.



A D T

EUT TEST CONDITION		MEASUREMENT DETAIL	
CHANNEL	High Channel	FREQUENCY RANGE	Below 1000MHz
MODULATION TYPE	FM	DETECTOR FUNCTION	Quasi-Peak
INPUT POWER (SYSTEM)	120Vac, 60 Hz	ENVIRONMENTAL CONDITIONS	23deg. C, 68%RH, 10262hPa
TEST MODE	A	TESTED BY	Lori Chiu

ANTENNA POLARITY & TEST DISTANCE: HORIZONTAL AT 3 M								
No.	Freq. (MHz)	Emission Level (dBuV/m)	Limit (dBuV/m)	Margin (dB)	Antenna Height (m)	Table Angle (Degree)	Raw Value (dBuV)	Correction Factor (dB/m)
1	94.06	34.79 QP	43.50	-8.71	2.00 H	346	25.53	9.26
2	152.39	38.31 QP	43.50	-5.19	2.00 H	64	24.45	13.86
3	230.16	43.18 QP	46.00	-2.82	1.50 H	304	31.23	11.94
4	727.90	36.98 QP	46.00	-9.02	2.00 H	226	13.57	23.41
5	790.12	40.63 QP	46.00	-5.37	1.25 H	10	15.58	25.05
6	860.11	38.45 QP	46.00	-7.55	1.00 H	40	12.72	25.73
ANTENNA POLARITY & TEST DISTANCE: VERTICAL AT 3 M								
No.	Freq. (MHz)	Emission Level (dBuV/m)	Limit (dBuV/m)	Margin (dB)	Antenna Height (m)	Table Angle (Degree)	Raw Value (dBuV)	Correction Factor (dB/m)
1	94.06	35.84 QP	43.50	-7.66	1.25 V	103	26.58	9.26
2	230.16	39.29 QP	46.00	-6.71	1.00 V	334	27.35	11.94
3	733.73	37.63 QP	46.00	-8.37	1.00 V	112	14.08	23.55
4	790.12	41.32 QP	46.00	-4.68	1.00 V	70	16.27	25.05
5	860.11	40.15 QP	46.00	-5.85	1.25 V	205	14.42	25.73
6	912.61	37.87 QP	46.00	-8.13	1.25 V	202	11.66	26.21

- REMARKS:**
1. Emission level(dBuV/m)=Raw Value(dBuV) + Correction Factor(dB/m)
 2. Correction Factor(dB/m) = Antenna Factor (dB/m) + Cable Factor (dB)
 3. The other emission levels were very low against the limit.
 4. Margin value = Emission level – Limit value.



A D T

EUT TEST CONDITION		MEASUREMENT DETAIL	
CHANNEL	Low Channel	FREQUENCY RANGE	Below 1000MHz
MODULATION TYPE	FM	DETECTOR FUNCTION	Quasi-Peak
INPUT POWER (SYSTEM)	120Vac, 60 Hz	ENVIRONMENTAL CONDITIONS	23deg. C, 68%RH, 1026hPa
TEST MODE	B	TESTED BY	Match Tsui

ANTENNA POLARITY & TEST DISTANCE: HORIZONTAL AT 3 M								
No.	Freq. (MHz)	Emission Level (dBuV/m)	Limit (dBuV/m)	Margin (dB)	Antenna Height (m)	Table Angle (Degree)	Raw Value (dBuV)	Correction Factor (dB/m)
1	57.12	33.37 QP	40.00	-6.63	1.25 H	307	19.90	13.48
2	115.45	31.88 QP	43.50	-11.62	1.50 H	100	20.68	11.20
3	148.50	40.75 QP	43.50	-2.75	1.25 H	307	27.05	13.70
4	179.61	38.05 QP	43.50	-5.45	2.00 H	196	25.82	12.23
5	206.83	41.25 QP	43.50	-2.25	1.25 H	121	30.35	10.90
6	230.16	43.97 QP	46.00	-2.03	1.50 H	139	32.03	11.94
7	276.82	41.47 QP	46.00	-4.53	1.25 H	145	28.20	13.27
8	300.16	43.15 QP	46.00	-2.85	1.25 H	307	29.48	13.67
9	368.21	37.52 QP	46.00	-8.48	1.00 H	118	22.23	15.29
10	498.47	34.09 QP	46.00	-11.91	1.50 H	205	14.90	19.19
11	554.86	35.06 QP	46.00	-10.94	1.50 H	223	14.18	20.88

ANTENNA POLARITY & TEST DISTANCE: VERTICAL AT 3 M								
No.	Freq. (MHz)	Emission Level (dBuV/m)	Limit (dBuV/m)	Margin (dB)	Antenna Height (m)	Table Angle (Degree)	Raw Value (dBuV)	Correction Factor (dB/m)
1	57.12	37.67 QP	40.00	-2.33	1.50 V	37	24.19	13.48
2	115.45	34.51 QP	43.50	-8.99	1.25 V	136	23.31	11.20
3	148.50	32.47 QP	43.50	-11.03	2.50 V	259	18.77	13.70
4	183.50	36.47 QP	43.50	-7.03	1.25 V	193	24.55	11.92
5	206.83	40.79 QP	43.50	-2.71	1.25 V	322	29.89	10.90
6	230.16	43.33 QP	46.00	-2.67	1.00 V	232	31.39	11.94
7	276.82	34.93 QP	46.00	-11.07	2.00 V	31	21.66	13.27
8	300.16	35.04 QP	46.00	-10.96	2.50 V	262	21.36	13.67

- REMARKS:**
1. Emission level(dBuV/m)=Raw Value(dBuV) + Correction Factor(dB/m)
 2. Correction Factor(dB/m) = Antenna Factor (dB/m) + Cable Factor (dB)
 3. The other emission levels were very low against the limit.
 4. Margin value = Emission level – Limit value.



A D T

EUT TEST CONDITION		MEASUREMENT DETAIL	
CHANNEL	Middle Channel	FREQUENCY RANGE	Below 1000MHz
MODULATION TYPE	FM	DETECTOR FUNCTION	Quasi-Peak
INPUT POWER (SYSTEM)	120Vac, 60 Hz	ENVIRONMENTAL CONDITIONS	23deg. C, 68%RH, 1026hPa
TEST MODE	B	TESTED BY	Match Tsui

ANTENNA POLARITY & TEST DISTANCE: HORIZONTAL AT 3 M								
No.	Freq. (MHz)	Emission Level (dBuV/m)	Limit (dBuV/m)	Margin (dB)	Antenna Height (m)	Table Angle (Degree)	Raw Value (dBuV)	Correction Factor (dB/m)
1	59.06	28.34 QP	40.00	-11.66	1.00 H	295	14.92	13.42
2	148.50	41.02 QP	43.50	-2.48	2.00 H	346	27.32	13.70
3	183.50	37.83 QP	43.50	-5.67	1.50 H	313	25.92	11.92
4	206.83	41.24 QP	43.50	-2.26	1.25 H	112	30.34	10.90
5	230.16	43.34 QP	46.00	-2.66	1.25 H	145	31.40	11.94
6	276.82	42.21 QP	46.00	-3.79	1.00 H	142	28.94	13.27
7	300.16	42.83 QP	46.00	-3.17	1.25 H	271	29.15	13.67
8	368.21	38.25 QP	46.00	-7.75	1.00 H	103	22.96	15.29
ANTENNA POLARITY & TEST DISTANCE: VERTICAL AT 3 M								
No.	Freq. (MHz)	Emission Level (dBuV/m)	Limit (dBuV/m)	Margin (dB)	Antenna Height (m)	Table Angle (Degree)	Raw Value (dBuV)	Correction Factor (dB/m)
1	59.06	37.64 QP	40.00	-2.36	1.25 V	163	24.22	13.42
2	80.45	33.49 QP	40.00	-6.51	1.50 V	61	25.36	8.12
3	183.50	36.03 QP	43.50	-7.47	1.25 V	13	24.11	11.92
4	206.83	40.72 QP	43.50	-2.78	1.25 V	109	29.82	10.90
5	230.16	42.83 QP	46.00	-3.17	1.00 V	229	30.89	11.94
6	276.82	34.79 QP	46.00	-11.21	2.00 V	46	21.52	13.27

- REMARKS:**
1. Emission level(dBuV/m)=Raw Value(dBuV) + Correction Factor(dB/m)
 2. Correction Factor(dB/m) = Antenna Factor (dB/m) + Cable Factor (dB)
 3. The other emission levels were very low against the limit.
 4. Margin value = Emission level – Limit value.



A D T

EUT TEST CONDITION		MEASUREMENT DETAIL	
CHANNEL	High Channel	FREQUENCY RANGE	Below 1000MHz
MODULATION TYPE	FM	DETECTOR FUNCTION	Quasi-Peak
INPUT POWER (SYSTEM)	120Vac, 60 Hz	ENVIRONMENTAL CONDITIONS	23deg. C, 68%RH, 1026hPa
TEST MODE	B	TESTED BY	Match Tsui

ANTENNA POLARITY & TEST DISTANCE: HORIZONTAL AT 3 M								
No.	Freq. (MHz)	Emission Level (dBuV/m)	Limit (dBuV/m)	Margin (dB)	Antenna Height (m)	Table Angle (Degree)	Raw Value (dBuV)	Correction Factor (dB/m)
1	57.12	32.93 QP	40.00	-7.07	1.25 H	76	19.45	13.48
2	148.50	39.97 QP	43.50	-3.53	1.50 H	355	26.27	13.70
3	183.50	38.20 QP	43.50	-5.30	1.50 H	70	26.28	11.92
4	206.83	41.02 QP	43.50	-2.48	1.50 H	88	30.12	10.90
5	230.16	43.44 QP	46.00	-2.56	2.00 H	130	31.50	11.94
6	276.82	39.50 QP	46.00	-6.50	1.00 H	223	26.23	13.27
7	323.49	40.21 QP	46.00	-5.79	1.00 H	109	25.99	14.22
8	368.21	37.89 QP	46.00	-8.11	1.00 H	100	22.60	15.29
ANTENNA POLARITY & TEST DISTANCE: VERTICAL AT 3 M								
No.	Freq. (MHz)	Emission Level (dBuV/m)	Limit (dBuV/m)	Margin (dB)	Antenna Height (m)	Table Angle (Degree)	Raw Value (dBuV)	Correction Factor (dB/m)
1	57.12	37.01 QP	40.00	-2.99	1.25 V	250	23.53	13.48
2	62.95	34.02 QP	40.00	-5.98	1.00 V	175	21.17	12.85
3	183.50	36.03 QP	43.50	-7.47	1.00 V	28	24.12	11.92
4	206.83	41.25 QP	43.50	-2.25	1.00 V	277	30.35	10.90
5	230.16	43.93 QP	46.00	-2.07	1.00 V	241	31.98	11.94
6	253.49	37.17 QP	46.00	-8.83	2.00 V	313	24.28	12.89
7	300.16	35.91 QP	46.00	-10.09	1.25 V	199	22.23	13.67

- REMARKS:**
1. Emission level(dBuV/m)=Raw Value(dBuV) + Correction Factor(dB/m)
 2. Correction Factor(dB/m) = Antenna Factor (dB/m) + Cable Factor (dB)
 3. The other emission levels were very low against the limit.
 4. Margin value = Emission level – Limit value.



A D T

EUT TEST CONDITION		MEASUREMENT DETAIL	
CHANNEL	Low Channel	FREQUENCY RANGE	Below 1000MHz
MODULATION TYPE	FM	DETECTOR FUNCTION	Quasi-Peak
INPUT POWER (SYSTEM)	120Vac, 60 Hz	ENVIRONMENTAL CONDITIONS	23deg. C, 68%RH, 10262hPa
TEST MODE	C	TESTED BY	Match Tsui

ANTENNA POLARITY & TEST DISTANCE: HORIZONTAL AT 3 M								
No.	Freq. (MHz)	Emission Level (dBuV/m)	Limit (dBuV/m)	Margin (dB)	Antenna Height (m)	Table Angle (Degree)	Raw Value (dBuV)	Correction Factor (dB/m)
1	59.06	33.13 QP	40.00	-6.87	1.50 H	19	19.71	13.42
2	115.45	37.95 QP	43.50	-5.55	1.50 H	97	26.75	11.20
3	132.95	30.52 QP	43.50	-12.98	2.50 H	100	18.27	12.25
4	166.00	30.57 QP	43.50	-12.93	1.50 H	118	17.31	13.25
5	206.83	32.85 QP	43.50	-10.65	2.00 H	76	21.95	10.90
6	276.82	32.67 QP	46.00	-13.33	1.00 H	130	19.40	13.27
7	331.26	35.55 QP	46.00	-10.45	1.00 H	181	21.14	14.40
8	500.42	41.14 QP	46.00	-4.86	1.50 H	241	21.89	19.25
9	663.74	38.86 QP	46.00	-7.14	1.25 H	73	16.43	22.43
10	700.68	33.29 QP	46.00	-12.71	1.50 H	238	10.54	22.75
11	830.95	37.45 QP	46.00	-8.55	1.50 H	61	11.94	25.51

ANTENNA POLARITY & TEST DISTANCE: VERTICAL AT 3 M								
No.	Freq. (MHz)	Emission Level (dBuV/m)	Limit (dBuV/m)	Margin (dB)	Antenna Height (m)	Table Angle (Degree)	Raw Value (dBuV)	Correction Factor (dB/m)
1	57.12	37.84 QP	40.00	-2.16	1.00 V	13	24.36	13.48
2	115.45	40.06 QP	43.50	-3.44	1.50 V	304	28.86	11.20
3	132.95	33.94 QP	43.50	-9.56	1.25 V	163	21.68	12.25
4	309.88	40.12 QP	46.00	-5.88	1.00 V	202	26.22	13.90
5	399.31	34.95 QP	46.00	-11.05	1.00 V	277	18.90	16.04
6	467.36	32.96 QP	46.00	-13.04	1.25 V	223	14.72	18.25
7	500.42	41.35 QP	46.00	-4.65	1.25 V	256	22.10	19.25
8	667.63	38.35 QP	46.00	-7.65	1.00 V	82	15.89	22.46
9	712.35	32.07 QP	46.00	-13.93	1.25 V	199	9.04	23.03
10	830.95	33.95 QP	46.00	-12.05	1.50 V	322	8.44	25.51

- REMARKS:**
1. Emission level(dBuV/m)=Raw Value(dBuV) + Correction Factor(dB/m)
 2. Correction Factor(dB/m) = Antenna Factor (dB/m) + Cable Factor (dB)
 3. The other emission levels were very low against the limit.
 4. Margin value = Emission level – Limit value.



A D T

EUT TEST CONDITION		MEASUREMENT DETAIL	
CHANNEL	Middle Channel	FREQUENCY RANGE	Below 1000MHz
MODULATION TYPE	FM	DETECTOR FUNCTION	Quasi-Peak
INPUT POWER (SYSTEM)	120Vac, 60 Hz	ENVIRONMENTAL CONDITIONS	23deg. C, 68%RH, 10262hPa
TEST MODE	C	TESTED BY	Match Tsui

ANTENNA POLARITY & TEST DISTANCE: HORIZONTAL AT 3 M

No.	Freq. (MHz)	Emission Level (dBuV/m)	Limit (dBuV/m)	Margin (dB)	Antenna Height (m)	Table Angle (Degree)	Raw Value (dBuV)	Correction Factor (dB/m)
1	57.12	32.69 QP	40.00	-7.31	2.00 H	10	19.21	13.48
2	62.95	28.51 QP	40.00	-11.49	1.50 H	10	15.66	12.85
3	148.50	37.13 QP	43.50	-6.37	1.25 H	295	23.43	13.70
4	166.00	29.99 QP	43.50	-13.51	1.50 H	253	16.74	13.25
5	206.83	29.69 QP	43.50	-13.81	1.25 H	343	18.80	10.90
6	280.71	35.01 QP	46.00	-10.99	1.00 H	226	21.68	13.34
7	331.26	37.48 QP	46.00	-8.52	1.00 H	199	23.08	14.40
8	444.03	36.22 QP	46.00	-9.78	2.50 H	112	18.69	17.52
9	500.42	40.78 QP	46.00	-5.22	1.50 H	238	21.53	19.25
10	663.74	38.58 QP	46.00	-7.42	1.25 H	79	16.15	22.43
11	830.95	37.47 QP	46.00	-8.53	2.00 H	355	11.96	25.51

ANTENNA POLARITY & TEST DISTANCE: VERTICAL AT 3 M

No.	Freq. (MHz)	Emission Level (dBuV/m)	Limit (dBuV/m)	Margin (dB)	Antenna Height (m)	Table Angle (Degree)	Raw Value (dBuV)	Correction Factor (dB/m)
1	57.12	37.74 QP	40.00	-2.26	1.00 V	10	24.26	13.48
2	62.95	35.74 QP	40.00	-4.26	1.00 V	328	22.89	12.85
3	132.95	36.86 QP	43.50	-6.64	1.50 V	106	24.60	12.25
4	356.54	41.77 QP	46.00	-4.23	1.00 V	151	26.76	15.00
5	465.42	32.79 QP	46.00	-13.21	1.00 V	238	14.60	18.19
6	500.42	41.98 QP	46.00	-4.02	1.25 V	256	22.73	19.25
7	564.58	35.10 QP	46.00	-10.90	1.25 V	175	14.00	21.10
8	628.74	32.07 QP	46.00	-13.93	1.50 V	106	9.92	22.14
9	665.68	37.65 QP	46.00	-8.35	2.00 V	316	15.21	22.45
10	700.68	33.84 QP	46.00	-12.16	1.00 V	346	11.10	22.75
11	799.84	35.16 QP	46.00	-10.84	2.50 V	31	9.85	25.32
12	830.95	37.10 QP	46.00	-8.90	1.00 V	43	11.59	25.51
13	935.94	35.67 QP	46.00	-10.33	1.50 V	310	9.28	26.38

- REMARKS:**
1. Emission level(dBuV/m)=Raw Value(dBuV) + Correction Factor(dB/m)
 2. Correction Factor(dB/m) = Antenna Factor (dB/m) + Cable Factor (dB)
 3. The other emission levels were very low against the limit.
 4. Margin value = Emission level – Limit value.



A D T

EUT TEST CONDITION		MEASUREMENT DETAIL	
CHANNEL	High Channel	FREQUENCY RANGE	Below 1000MHz
MODULATION TYPE	FM	DETECTOR FUNCTION	Quasi-Peak
INPUT POWER (SYSTEM)	120Vac, 60 Hz	ENVIRONMENTAL CONDITIONS	23deg. C, 68%RH, 1026hPa
TEST MODE	C	TESTED BY	Match Tsui

ANTENNA POLARITY & TEST DISTANCE: HORIZONTAL AT 3 M								
No.	Freq. (MHz)	Emission Level (dBuV/m)	Limit (dBuV/m)	Margin (dB)	Antenna Height (m)	Table Angle (Degree)	Raw Value (dBuV)	Correction Factor (dB/m)
1	57.12	32.25 QP	40.00	-7.75	1.25 H	4	18.78	13.48
2	62.95	26.99 QP	40.00	-13.01	1.50 H	10	14.14	12.85
3	148.50	32.90 QP	43.50	-10.60	2.00 H	265	19.20	13.70
4	276.82	33.08 QP	46.00	-12.92	1.00 H	133	19.81	13.27
5	331.26	36.11 QP	46.00	-9.89	1.00 H	265	21.71	14.40
6	500.42	39.13 QP	46.00	-6.87	1.50 H	154	19.88	19.25
7	663.74	37.46 QP	46.00	-8.54	1.25 H	79	15.03	22.43
8	830.95	33.19 QP	46.00	-12.81	1.00 H	10	7.68	25.51
ANTENNA POLARITY & TEST DISTANCE: VERTICAL AT 3 M								
No.	Freq. (MHz)	Emission Level (dBuV/m)	Limit (dBuV/m)	Margin (dB)	Antenna Height (m)	Table Angle (Degree)	Raw Value (dBuV)	Correction Factor (dB/m)
1	57.12	37.88 QP	40.00	-2.12	1.00 V	346	24.40	13.48
2	64.90	37.41 QP	40.00	-2.59	1.50 V	106	24.92	12.49
3	193.22	30.13 QP	43.50	-13.37	1.00 V	283	18.99	11.14
4	399.31	34.20 QP	46.00	-11.80	1.00 V	271	18.15	16.04
5	500.42	40.67 QP	46.00	-5.33	1.25 V	259	21.42	19.25
6	665.68	34.99 QP	46.00	-11.01	2.00 V	172	12.54	22.45
7	700.68	32.20 QP	46.00	-13.80	1.00 V	211	9.46	22.75
8	797.89	32.65 QP	46.00	-13.35	1.50 V	166	7.38	25.26
9	830.95	34.25 QP	46.00	-11.75	1.25 V	1	8.74	25.51

- REMARKS:**
1. Emission level(dBuV/m)=Raw Value(dBuV) + Correction Factor(dB/m)
 2. Correction Factor(dB/m) = Antenna Factor (dB/m) + Cable Factor (dB)
 3. The other emission levels were very low against the limit.
 4. Margin value = Emission level – Limit value.

4.3. EMISSION BAND MEASUREMENT

4.3.1. LIMITS OF EMISSION BAND MEASUREMENT

Emissions from the intentional radiator shall be confined within bands 200kHz wide centered on the operating frequency. The 200 kHz band shall lie wholly within the frequency range of 88 to 108MHz.

4.3.2. TEST INSTRUMENTS

Same as 4.2.2

4.3.3. TEST PROCEDURES

Same as 4.2.3

4.3.4. DEVIATION FROM TEST STANDARD

No deviation.

4.3.5. TEST SETUP

Same as 4.2.5

4.3.6. EUT OPERATING CONDITIONS

Same as 4.2.6



A D T

4.3.7. TEST RESULTS

CHANNEL	Low, Middle, High Channel	MODULATION TYPE	FM
INPUT POWER (SYSTEM)	120Vac, 60 Hz	ENVIRONMENTAL CONDITIONS	23deg. C, 68%RH, 1026hPa
TEST MODE	A	TESTED BY	Lori Chiu

CHANNEL	CHANNEL FREQUENCY (MHz)	20 dB BANDWIDTH (MHz)	MAXIMUM LIMIT (kHz)	PASS/FAIL
Low	88.10	0.174	200	PASS
Middle	98.00	0.169	200	PASS
High	107.90	0.176	200	PASS

Low Channel

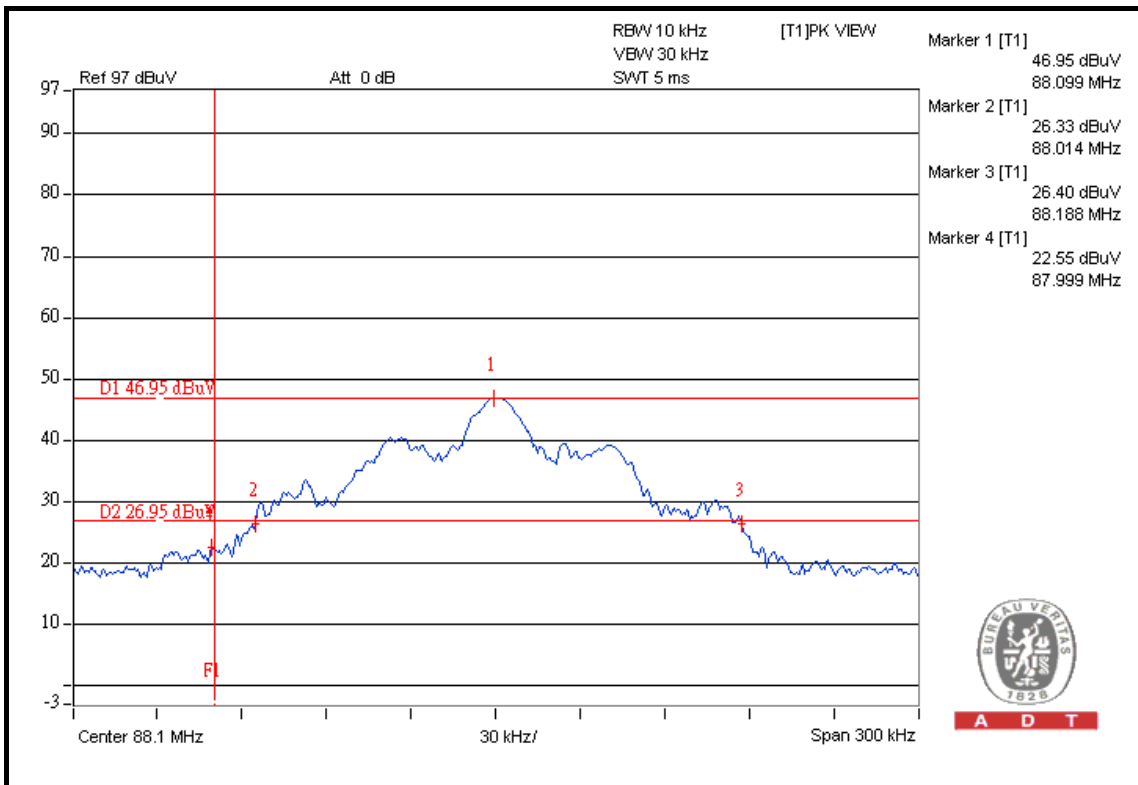



A D T

Middle Channel

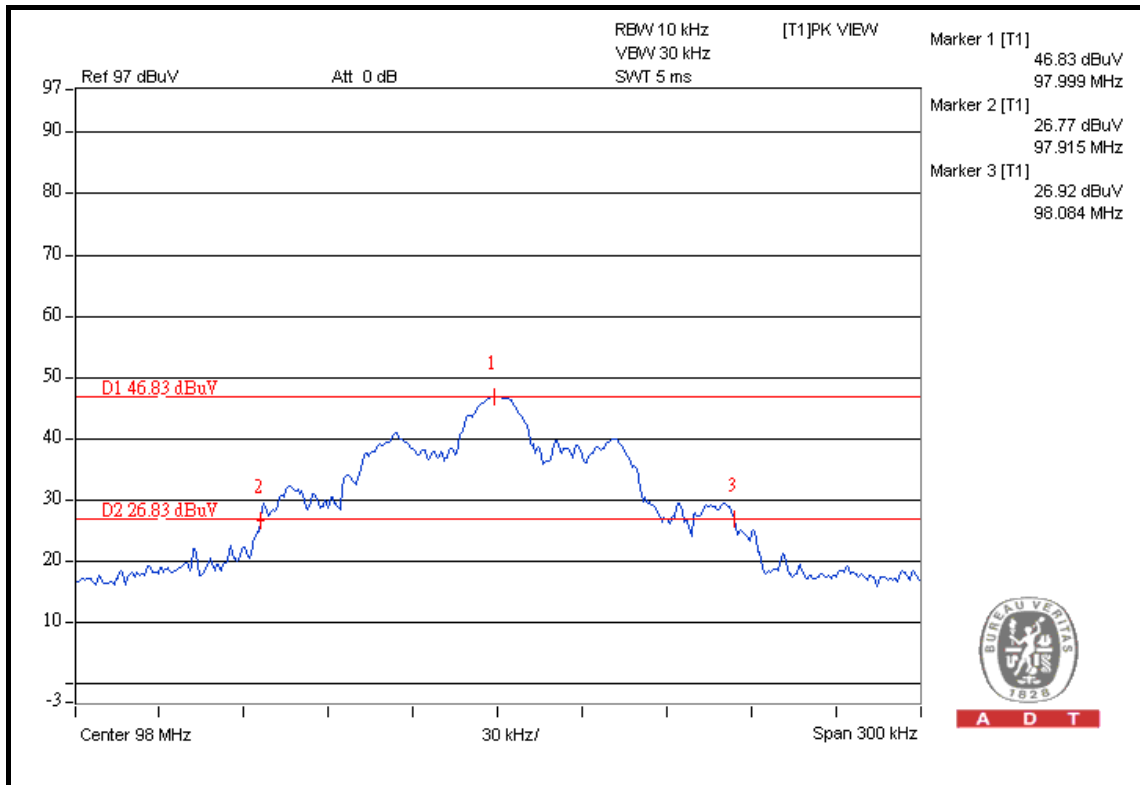

High Channel

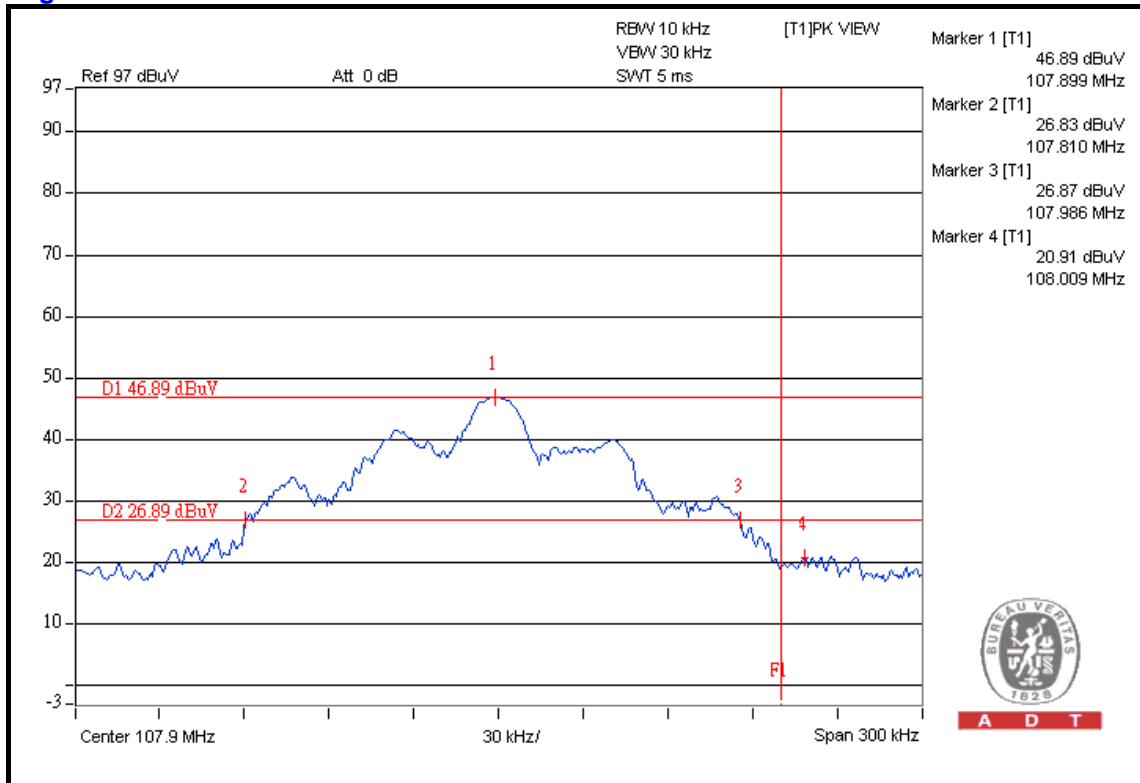



A D T

CHANNEL	Low, Middle, High Channel	MODULATION TYPE	FM
INPUT POWER (SYSTEM)	120Vac, 60 Hz	ENVIRONMENTAL CONDITIONS	23deg. C, 68%RH, 1026hPa
TEST MODE	B	TESTED BY	Lori Chiu

CHANNEL	CHANNEL FREQUENCY (MHz)	20 dB BANDWIDTH (MHz)	MAXIMUM LIMIT (kHz)	PASS/FAIL
Low	88.10	0.172	200	PASS
Middle	98.00	0.179	200	PASS
High	107.90	0.176	200	PASS

Low Channel

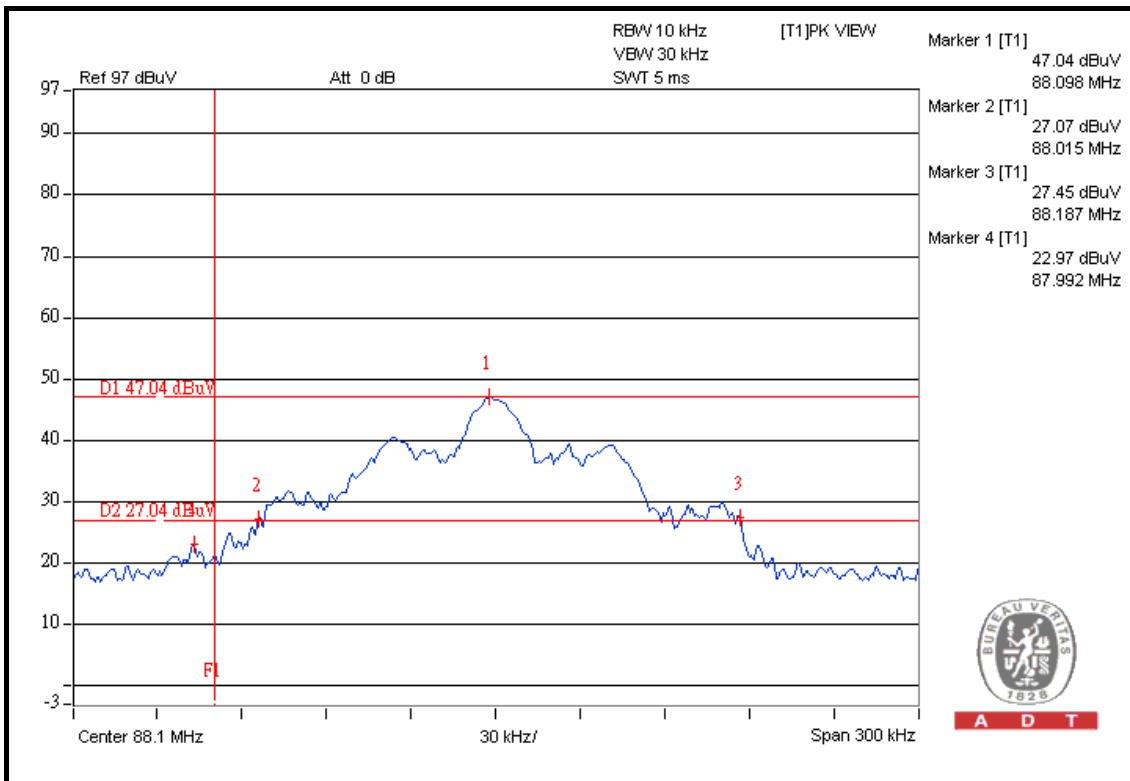



A D T

Middle Channel



A D T

High Channel

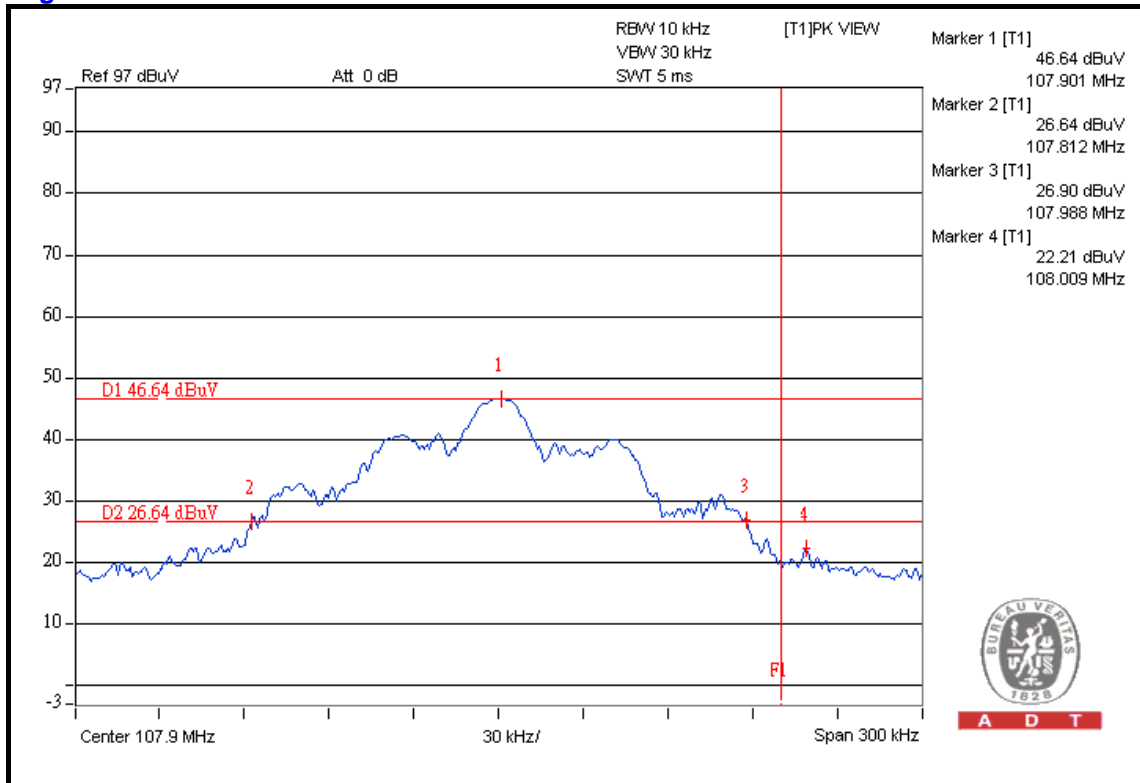

A D T



A D T

CHANNEL	Low, Middle, High Channel	MODULATION TYPE	FM
INPUT POWER (SYSTEM)	120Vac, 60 Hz	ENVIRONMENTAL CONDITIONS	23deg. C, 68%RH, 1026hPa
TEST MODE	C	TESTED BY	Lori Chiu

CHANNEL	CHANNEL FREQUENCY (MHz)	20 dB BANDWIDTH (MHz)	MAXIMUM LIMIT (kHz)	PASS/FAIL
Low	88.10	0.174	200	PASS
Middle	98.00	0.170	200	PASS
High	107.90	0.173	200	PASS

Low Channel

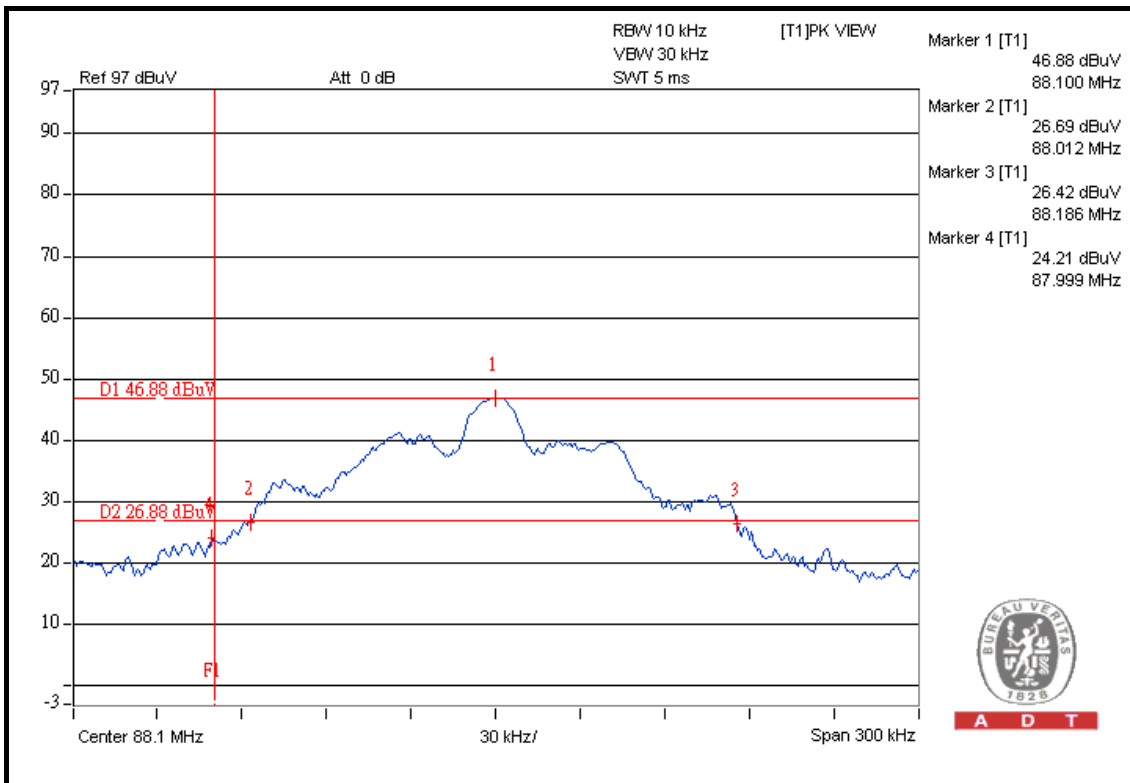



A D T

Middle Channel

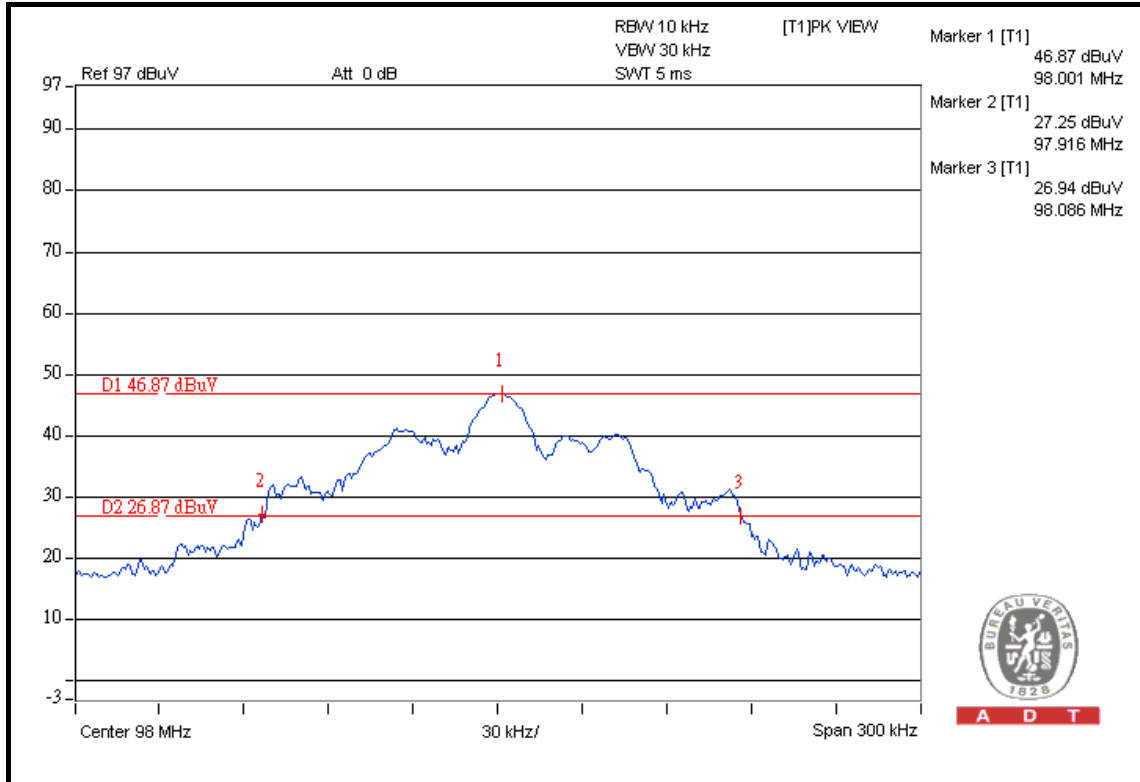

High Channel

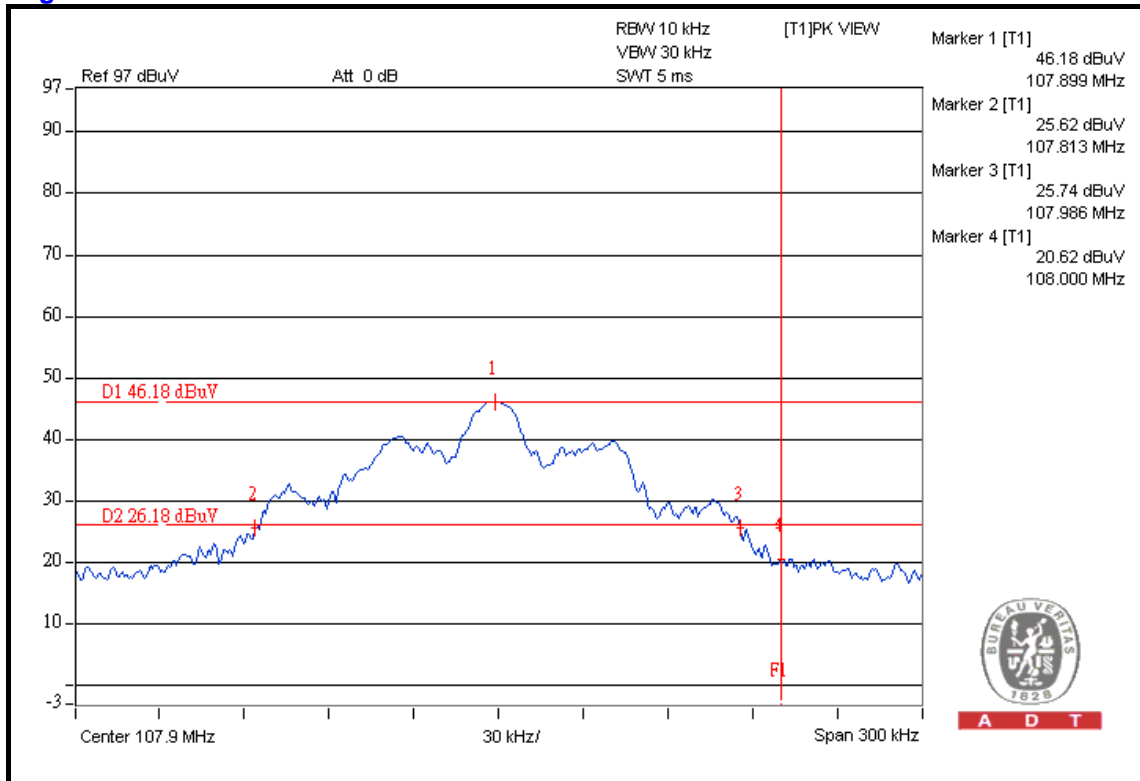

5. PHOTOGRAPHS OF THE TEST CONFIGURATION

Please refer to the attached file (Test Setup Photo).



6. INFORMATION ON THE TESTING LABORATORIES

We, Bureau Veritas Consumer Products Services (H.K.) Ltd., Taoyuan Branch, were founded in 1988 to provide our best service in EMC, Radio, Telecom and Safety consultation. Our laboratories are accredited and approved by the following approval agencies according to ISO/IEC 17025.

USA	FCC, NVLAP
Germany	TUV Rheinland
Japan	VCCI
Norway	NEMKO
Canada	INDUSTRY CANADA , CSA
R.O.C.	TAF, BSMI, NCC
Netherlands	Telefication
Singapore	GOST-ASIA(MOU)
Russia	CERTIS(MOU)

Copies of accreditation certificates of our laboratories obtained from approval agencies can be downloaded from our web site:

www.adt.com.tw/index.5/phtml. If you have any comments, please feel free to contact us at the following:

Linko EMC/RF Lab:
Tel: 886-2-26052180
Fax: 886-2-26051924

Hsin Chu EMC/RF Lab:
Tel: 886-3-5935343
Fax: 886-3-5935342

Hwa Ya EMC/RF/Safety Telecom Lab:
Tel: 886-3-3183232
Fax: 886-3-3185050

Web Site: www.adt.com.tw

The address and road map of all our labs can be found in our web site also.

7. APPENDIX A – MODIFICATIONS RECORDERS FOR ENGINEERING CHANGES TO THE EUT BY THE LAB

No any modifications are made to the EUT by the lab during the test.

--- END ---