

FCC Test Report

APPLICANT : Motorola, Inc.
EQUIPMENT : T215 Bluetooth Car Speakerphone
BRAND NAME : MOTOROLA
MODEL NAME : T215
FCC ID : IHDP6KG1
STANDARD : FCC Part 15 Subpart C §15.247
CLASSIFICATION : Digital Spread Spectrum (DSS)

The product sample received on May 07, 2009 and completely tested on May 12, 2009. We, SPORTON INTERNATIONAL INC., would like to declare that the tested sample has been evaluated in accordance with the procedures given in ANSI C63.4-2003 and shown compliance with the applicable technical standards.

The test results in this report apply exclusively to the tested model / sample. Without written approval of SPORTON INTERNATIONAL INC., the test report shall not be reproduced except in full.

Reviewed by:

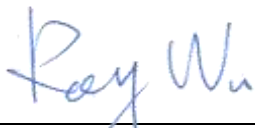

Roy Wu / Manager



SPORTON INTERNATIONAL INC.

No. 52, Hwa Ya 1st Rd., Hwa Ya Technology Park, Kwei-Shan Hsiang, Tao Yuan Hsien, Taiwan, R.O.C.



TABLE OF CONTENTS

REVISION HISTORY..... 3

SUMMARY OF TEST RESULT 4

1 GENERAL DESCRIPTION..... 5

 1.1 Applicant 5

 1.2 Manufacturer..... 5

 1.3 Feature of Equipment Under Test 5

 1.4 Testing Site 7

 1.5 Applied Standards 7

 1.6 Ancillary Equipment List 7

2 TEST CONFIGURATION OF EQUIPMENT UNDER TEST..... 8

 2.1 RF Output Power 8

 2.2 Test Mode..... 8

 2.3 Connection Diagram of Test System..... 9

 2.4 RF Utility 9

3 TEST RESULT 10

 3.1 Number of Channel Measurement 10

 3.2 20dB and 99% Bandwidth Measurement 12

 3.3 Hopping Channel Separation Measurement 25

 3.4 Dwell Time Measurement..... 28

 3.5 Peak Output Power Measurement 30

 3.6 Band Edges Measurement 33

 3.7 Radiated Emission Measurement..... 37

 3.8 Antenna Requirements 46

4 LIST OF MEASURING EQUIPMENT..... 47

5 UNCERTAINTY OF EVALUATION..... 48

6 CERTIFICATION OF TAF ACCREDITATION 49

APPENDIX A. PHOTOGRAPHS OF EUT

APPENDIX B. SETUP PHOTOGRAPHS



SUMMARY OF TEST RESULT

Report Section	FCC Rule	IC Rule	Description	Limit	Result	Remark
3.1	15.247(b)(1)	A8.4(2)	Number of Channels	≥ 15Chs	Pass	
3.2	15.247(a)(1)	A8.1(a)	20dB Bandwidth	NA	Pass	-
3.2	-	Gen 4.4.1	99% Bandwidth	-	Pass	-
3.3	15.247(a)(1)	A8.1(b)	Channel Separation	≥ 2/3 of 20dB BW	Pass	-
3.4	15.247(a)(1)	A8.1(d)	Dwell Time of Each Channel	≤ 0.4sec in 31.6sec period	Pass	-
3.5	15.247(a)(1)	A8.1(b)	Peak Output Power	≤ 1W	Pass	-
3.6	15.247(d)	A8.5	Frequency Band Edges	≤ 20dBc	Pass	-
3.7	15.247(d)	A8.5	Transmitter Radiated Emission	15.209(a) & 15.247(d)	Pass	Under limit 3.19 dB at 33.24 MHz
3.8	15.203 & 15.247(b)	A8.4	Antenna Requirement	N/A	Pass	-



1 General Description

1.1 Applicant

Motorola, Inc.

600 N. U.S. Highway 45, Libertyville, IL 60048, U.S.A.

1.2 Manufacturer

Merry Electronics (Shenzhen) CO., LTD.

No. 50, Mei Bao Road, Dalang Street, BaoAn District, Shenzhen City, Guangdong Province, China

1.3 Feature of Equipment Under Test

Product Feature & Specification	
Equipment	T215 Bluetooth Car Speakerphone
Brand Name	MOTOROLA
Model Name	T215
FCC ID	IHDP6KG1
Tx/Rx Frequency Range	2400 MHz ~ 2483.5 MHz
Number of Channels	79
Carrier Frequency of Each Channel	2402+n*1 MHz; n=0~78
Channel Spacing	1 MHz
Maximum Output Power to Antenna	Bluetooth EDR (3Mbps) : 3.95dBm (2.48 mW)
Antenna Type	PCB Antenna with gain -2 dBi
Antenna Connector Type	N/A
HW Version	Main Board: RD Daughter Board: RC
SW Version	20090514-1
Type of Modulation	Bluetooth (1Mbps) : GFSK Bluetooth EDR (2Mbps) : $\pi/4$ -DQPSK Bluetooth EDR (3Mbps) : 8-DPSK
EUT Stage	Production Unit

Remark: This test report recorded only product characteristics and test results of Digital Spread Spectrum (DSS).

List of Accessory:

Specification of Accessory		
Car Charger 1	Brand Name	MOTOROLA
	Model Name	SYN1830A
	Part Number	08070-SZ-1084109
	Power Rating	I/P: 10.8~33.0V; O/P: 4.75~5.25V
	Power Cord Type	2.3 meter non-shielded cable without ferrite core
Car Charger 2	Brand Name	MOTOROLA
	Model Name	SYN1830A
	Part Number	0735703-0825520
	Power Rating	I/P: 10.8~33.0V; O/P: 4.75~5.25V
	Power Cord Type	2.3 meter non-shielded cable without ferrite core

Remark:

1. Only the Car Charger 1 was used for the RF test.
2. The above EUT's information was declared by manufacturer. Please refer to the specifications or user's manual for more detailed description.
3. For accessories equipped with this EUT, please refer to the appendix of the external photo.



1.4 Testing Site

Test Site	SPORTON INTERNATIONAL INC.		
Test Site Location	No. 52, Hwa Ya 1 st Rd., Hwa Ya Technology Park, Kwei-Shan Hsiang, Tao Yuan Hsien, Taiwan, R.O.C. TEL: +886-3-3273456 / FAX: +886-3-3284978		
Test Site No.	Sporton Site No.		FCC/IC Registration No.
	TH02-HY	03CH06-HY	TW1022/4086B-1

1.5 Applied Standards

According to the specifications of the manufacturer, the EUT must comply with the requirements of the following standards:

- ♦ FCC Part 15 Subpart C §15.247
- ♦ FCC Public Notice DA 00-705
- ♦ ANSI C63.4-2003
- ♦ IC RSS-210 Issue 7

Remark:

1. All test items were verified and recorded according to the standards and without any deviation during the test.
2. This EUT has also been tested and complied with the requirements of FCC Part 15, Subpart B (DoC), recorded in a separate test report.

1.6 Ancillary Equipment List

Item	Equipment	Trade Name	Model Name	FCC ID	Data Cable	Power Cord
1.	BT Base Station	Anritsu	8852B	N/A	N/A	Unshielded, 1.8 m
2.	Car Battery	YUASA	46B24R(S)	N/A	N/A	N/A

2 Test Configuration of Equipment Under Test

2.1 RF Output Power

Preliminary tests were performed in different data rate and recorded the RF output power in the following table:

Channel	Frequency	Bluetooth RF Output Power		
		Data Rate / Modulation		
		GFSK	π /4-DQPSK	8-DPSK
		1Mbps	2Mbps	3Mbps
Ch00	2402MHz	1.64 dBm	3.74 dBm	3.95 dBm
Ch39	2441MHz	1.24 dBm	3.29 dBm	3.59 dBm
Ch78	2480MHz	0.22 dBm	2.23 dBm	2.53 dBm

Remark:

1. The data rate 3Mbps was set for all the test items due to the highest RF output power.
2. The EUT is programmed to transmit signals continuously for all testing.

2.2 Test Mode

The EUT has been associated with peripherals pursuant to ANSI C63.4-2003 and configuration operated in a manner tended to maximize its emission characteristics in a typical application. Frequency range investigated: radiation (9 kHz to the 10th harmonic of the highest fundamental frequency or to 40 GHz, whichever is lower).

Pre-scanned tests were conducted to determine the final configuration from all possible combinations.

The following tables are showing the test modes as the worst cases and recorded in this report.

Test Cases			
Test Item	Data Rate / Modulation		
	Bluetooth 1Mbps GFSK	Bluetooth EDR 2Mbps π /4-DQPSK	Bluetooth EDR 3Mbps 8-DPSK
Conducted TCs	<ul style="list-style-type: none"> ■ Mode 1: CH00_2402 MHz ■ Mode 2: CH39_2441 MHz ■ Mode 3: CH78_2480 MHz 	<ul style="list-style-type: none"> ■ Mode 4: CH00_2402 MHz ■ Mode 5: CH39_2441 MHz ■ Mode 6: CH78_2480 MHz 	<ul style="list-style-type: none"> ■ Mode 7: CH00_2402 MHz ■ Mode 8: CH39_2441 MHz ■ Mode 9: CH78_2480 MHz
Radiated TCs	N/A	N/A	<ul style="list-style-type: none"> ■ Mode 1: CH00_2402 MHz ■ Mode 2: CH39_2441 MHz ■ Mode 3: CH78_2480 MHz

Remark:

1. The worst case of conducted TCs is Bluetooth 3Mbps, only the test data of these modes was reported.
2. The worst cases of radiated emission were Bluetooth 3Mbps TX modes; only the test data of these modes were reported.

2.3 Connection Diagram of Test System

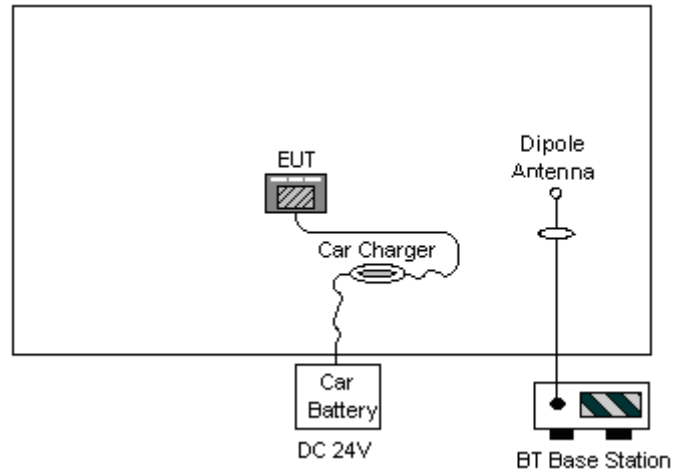

2.4 RF Utility

The following steps made the EUT into the engineering modes to contact with BT base station for transmitting and receiving signals continuously.

1. Power on the EUT
2. Press "S/E" & "V-" at the same time to enter pairing mode first
3. LEDs flashing alternately, then press "V-" and "Mute" at the same time

3 Test Result

3.1 Number of Channel Measurement

3.1.1 Limits of Number of Hopping Frequency

Frequency hopping systems in the 2400-2483.5 MHz band shall use at least 15 channels.

3.1.2 Measuring Instruments

See list of measuring instruments of this test report.

3.1.3 Test Procedure

1. The testing follows FCC Public Notice DA 00-705 Measurement Guidelines.
2. The RF output of EUT was connected to the spectrum analyzer by a low loss cable.
3. The modulation types of EUT are irrelevant to number of hopping channels deviation.
4. The EUT must have its hopping function enabled. Use the following spectrum analyzer settings:
Span = the frequency band of operation; RBW \geq 1% of the span; VBW \geq RBW; Sweep = auto;
Detector function = peak; Trace = max hold.
5. The number of hopping frequency used is defined as the device has the numbers of total channel.

3.1.4 Test Setup

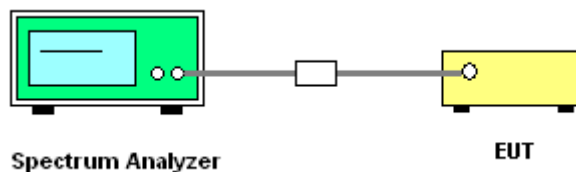



3.1.5 Test Result of Number of Hopping Frequency

Test Mode :	Mode 7~9	Temperature :	21~24°C
Test Engineer :	Ken Hsu	Relative Humidity :	41~45%
Number of Hopping Channels (Channel)		Limits (Channel)	Pass/Fail
79		> 15	Pass

Number of Hopping Channel Plot on Channel 00 - 78

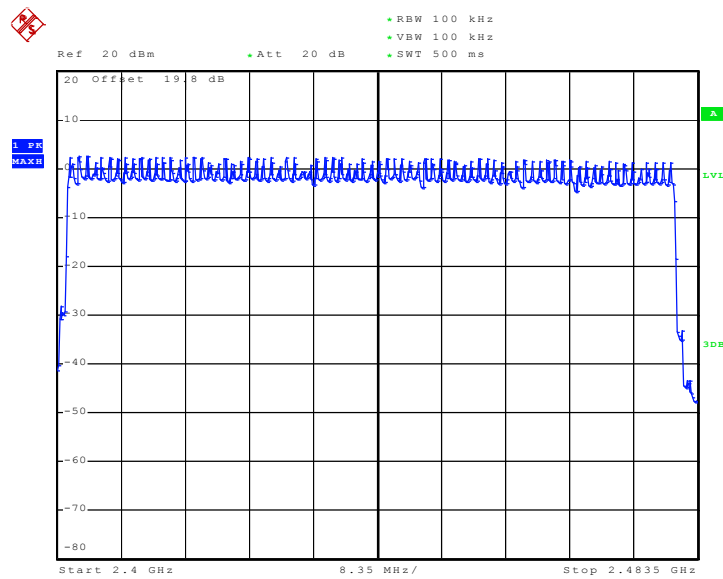

Date: 12.MAY.2009 16:33:03

3.2 20dB and 99% Bandwidth Measurement

3.2.1 Limit of 20dB Bandwidth

N/A

3.2.2 Measuring Instruments

See list of measuring instruments of this test report.

3.2.3 Test Procedures

1. The testing follows FCC Public Notice DA 00-705 Measurement Guidelines.
2. The RF output of EUT was connected to the spectrum analyzer by a low loss cable.
3. The EUT should be transmitting at its maximum data rate as the worst cases.
4. Use the following spectrum analyzer settings:
Span = approximately 2 to 3 times the 20 dB bandwidth, centered on a hopping channel;
RBW \geq 1% of the 20 dB bandwidth; VBW \geq RBW; Sweep = auto; Detector function = peak;
Trace = max hold.
5. The marker-delta reading at this point is the 20 dB bandwidth of the emission.

3.2.4 Test Setup

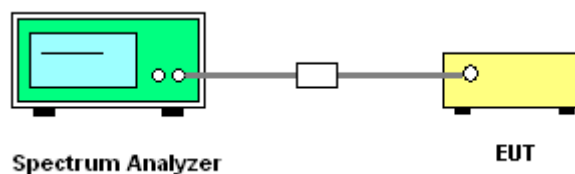



3.2.5 Test Result of 20dB Bandwidth

Test Mode :	Mode 1, 2, 3	Temperature :	21~24°C
Test Engineer :	Ken Hsu	Relative Humidity :	41~45%

Channel	Frequency (MHz)	20dB Bandwidth (MHz)
00	2402	0.842
39	2441	0.826
78	2480	0.830

20 dB Bandwidth Plot on Channel 00

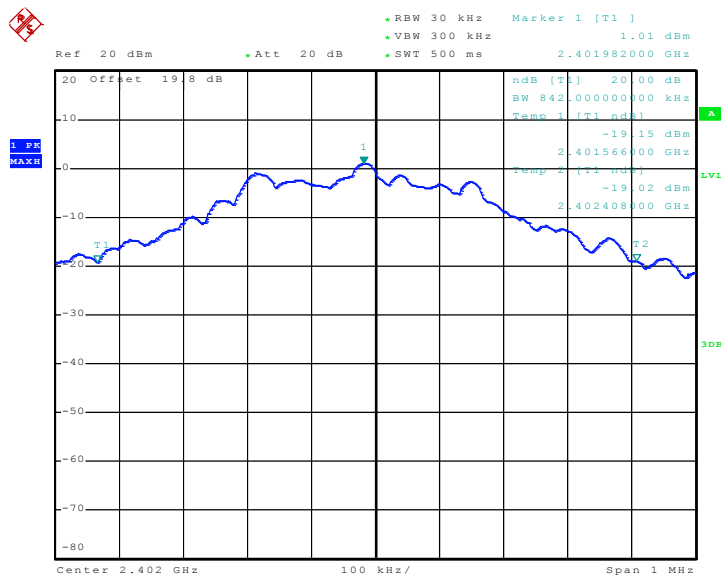

Date: 12.MAY.2009 12:17:17



20 dB Bandwidth Plot on Channel 39

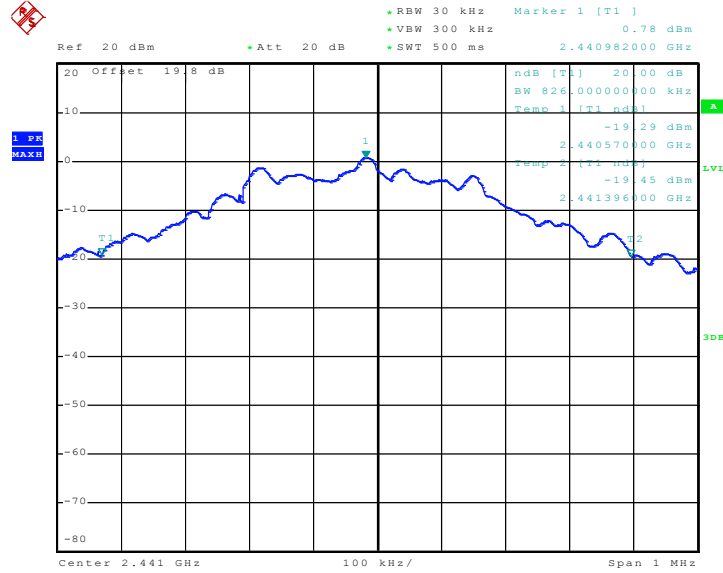

Date: 12.MAY.2009 12:17:41

20 dB Bandwidth Plot on Channel 78

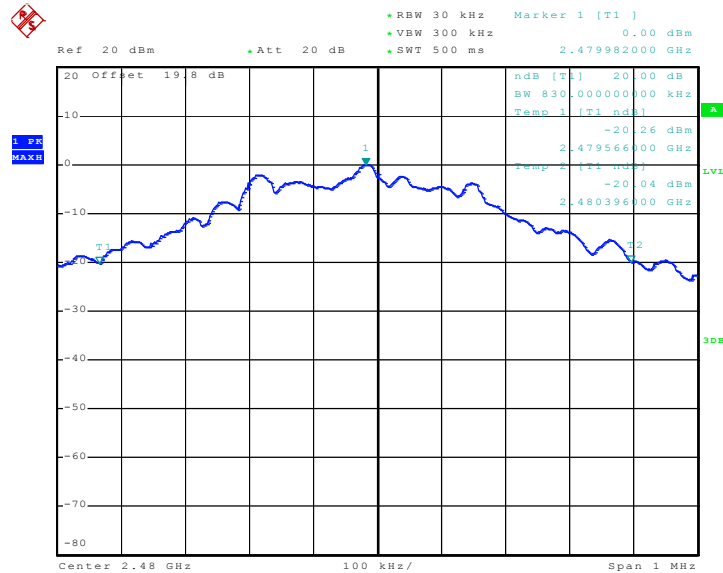

Date: 12.MAY.2009 12:18:08



Test Mode :	Mode 4, 5, 6	Temperature :	21~24°C
Test Engineer :	Ken Hsu	Relative Humidity :	41~45%

Channel	Frequency (MHz)	20dB Bandwidth (MHz)
00	2402	1.260
39	2441	1.264
78	2480	1.256

20 dB Bandwidth Plot on Channel 00

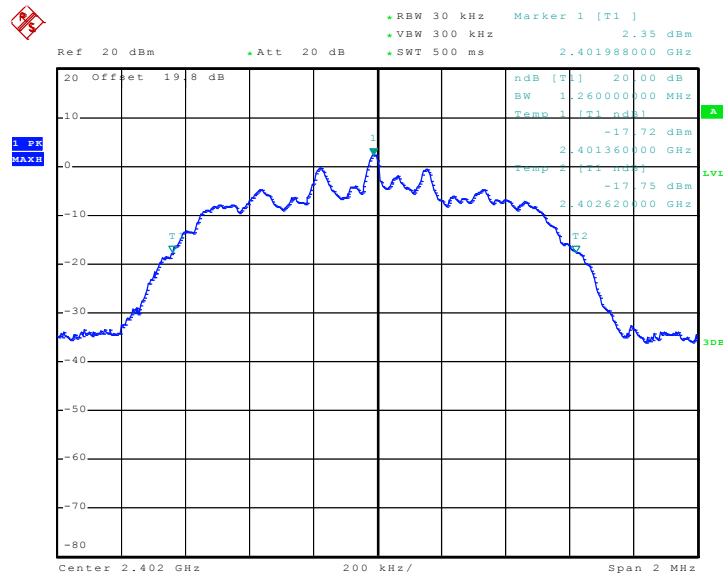

Date: 12.MAY.2009 15:39:26



20 dB Bandwidth Plot on Channel 39

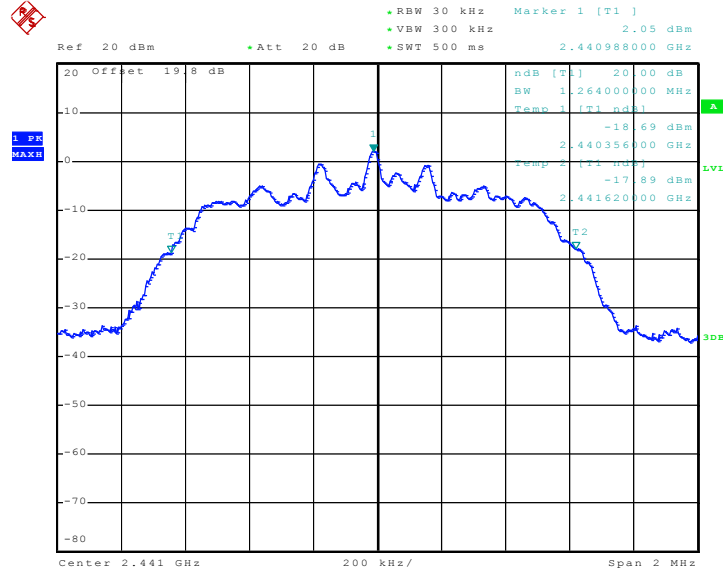

Date: 12.MAY.2009 15:39:56

20 dB Bandwidth Plot on Channel 78

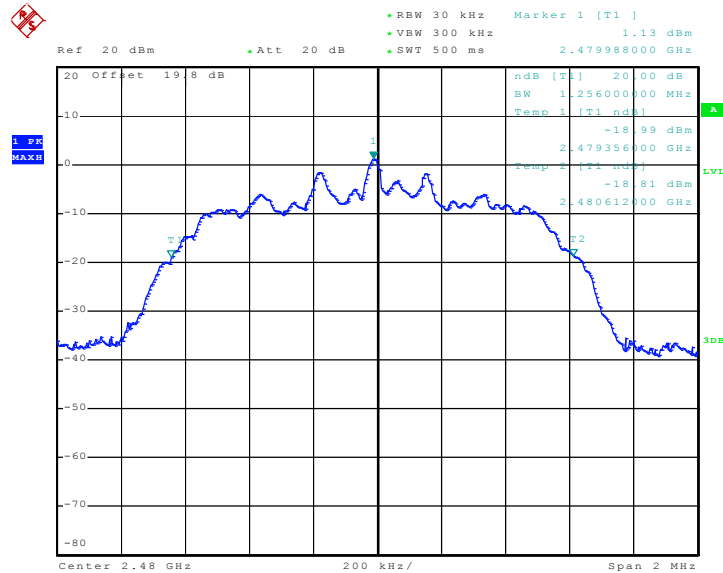

Date: 12.MAY.2009 15:40:19



Test Mode :	Mode 7, 8, 9	Temperature :	21~24°C
Test Engineer :	Ken Hsu	Relative Humidity :	41~45%

Channel	Frequency (MHz)	20dB Bandwidth (MHz)
00	2402	1.288
39	2441	1.288
78	2480	1.284

20 dB Bandwidth Plot on Channel 00

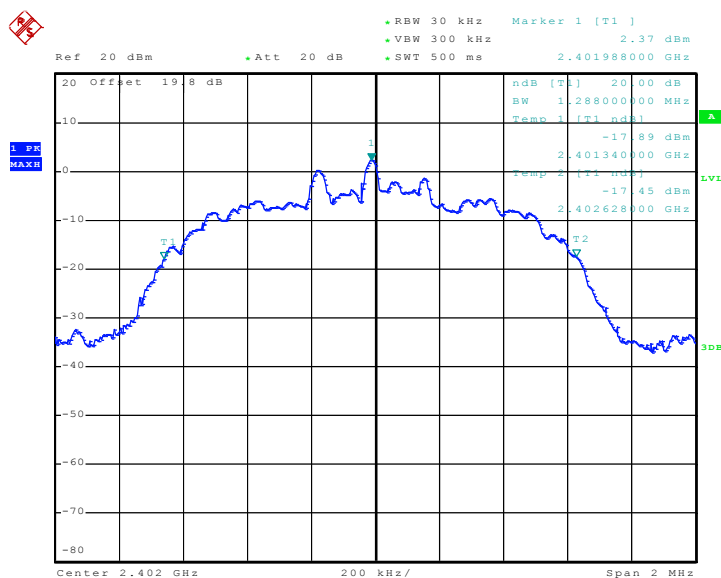

Date: 12.MAY.2009 15:40:48



20 dB Bandwidth Plot on Channel 39

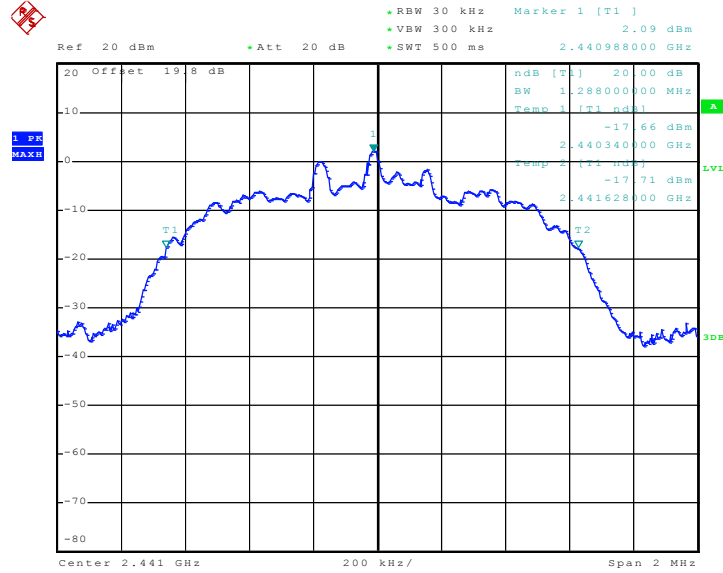

Date: 12.MAY.2009 15:41:13

20 dB Bandwidth Plot on Channel 78

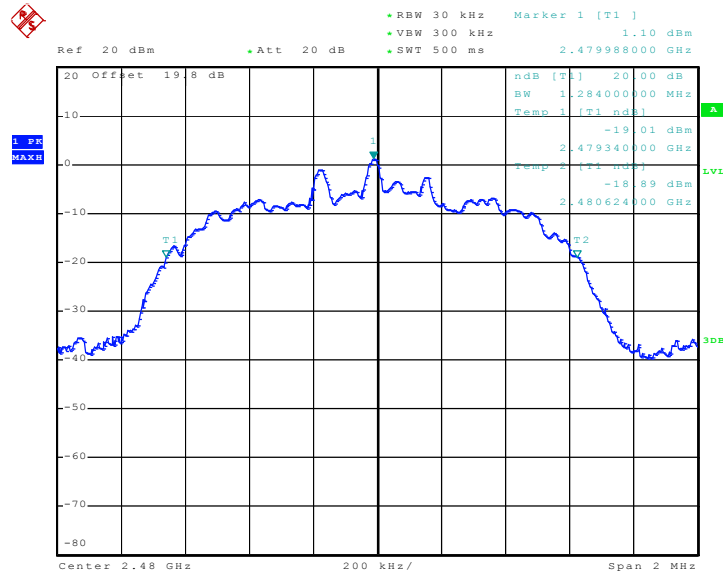

Date: 12.MAY.2009 15:41:39



3.2.6 Test Result of 99% Occupied Bandwidth

Test Mode :	Mode 1, 2, 3	Temperature :	21~24°C
Test Engineer :	Ken Hsu	Relative Humidity :	41~45%

Channel	Frequency (MHz)	99% Occupied Bandwidth (MHz)
00	2402	0.800
39	2441	0.802
78	2480	0.800

99% Bandwidth Plot on Channel 00

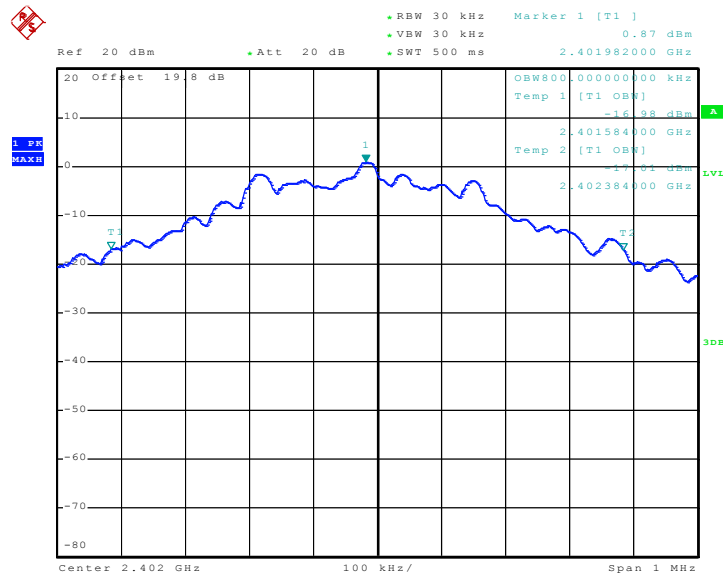

Date: 12.MAY.2009 12:19:20



99% Occupied Bandwidth Plot on Channel 39

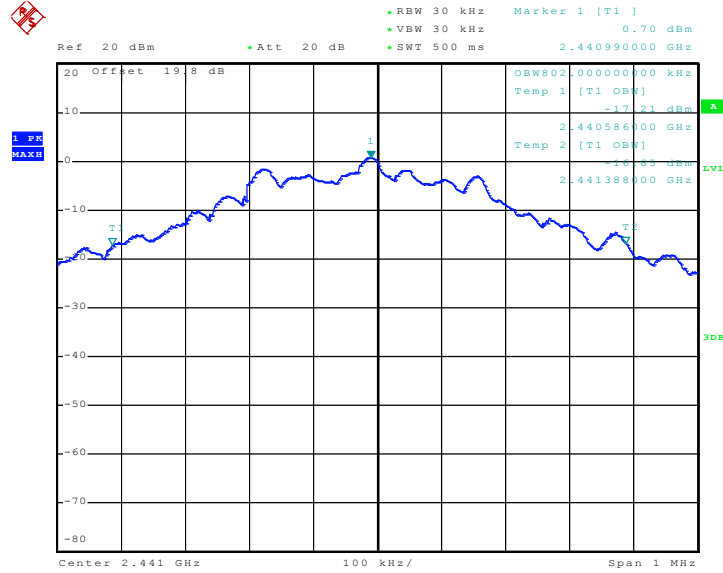

Date: 12.MAY.2009 13:51:40

99% Occupied Bandwidth Plot on Channel 78

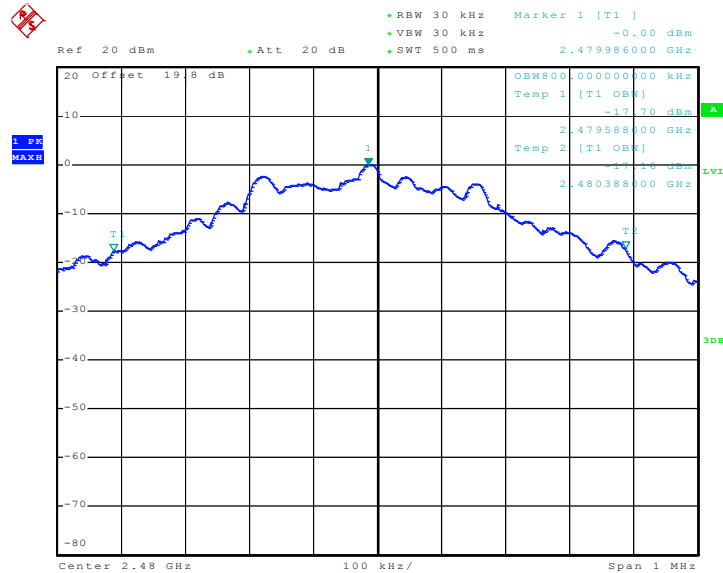

Date: 12.MAY.2009 13:52:05



Test Mode :	Mode 4, 5, 6	Temperature :	21~24°C
Test Engineer :	Ken Hsu	Relative Humidity :	41~45%

Channel	Frequency (MHz)	99% Occupied Bandwidth (MHz)
00	2402	1.188
39	2441	1.184
78	2480	1.180

99% Bandwidth Plot on Channel 00

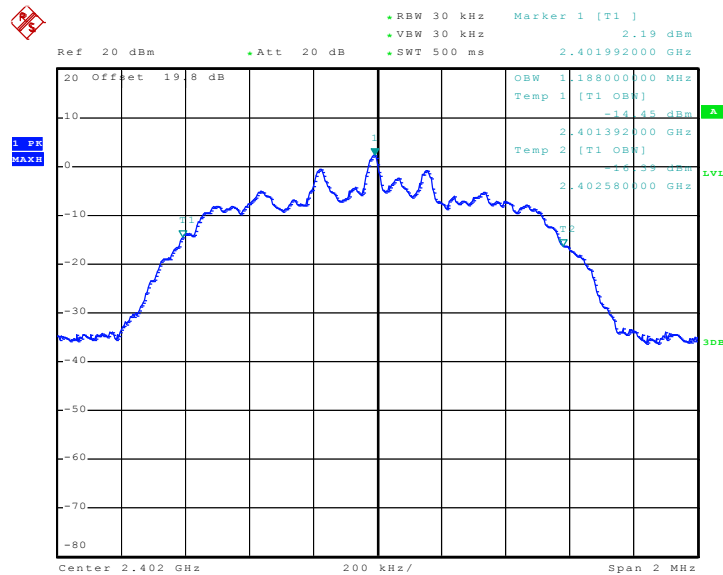

Date: 12.MAY.2009 15:42:36



99% Occupied Bandwidth Plot on Channel 39

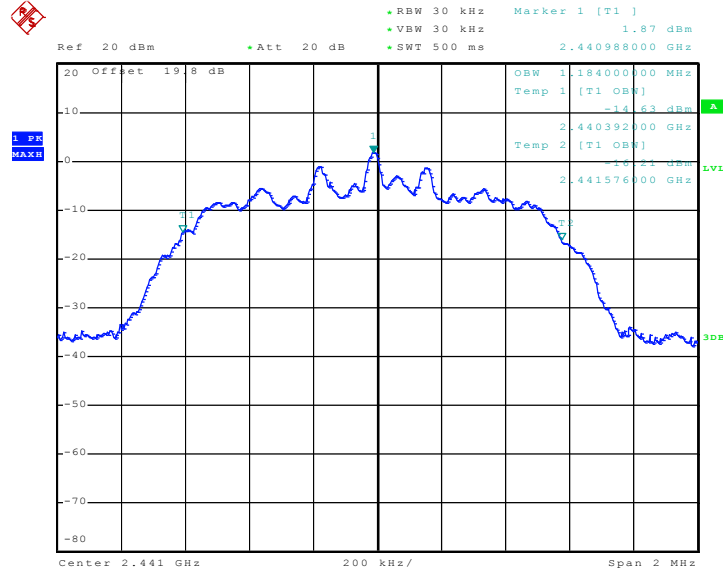

Date: 12.MAY.2009 15:45:33

99% Occupied Bandwidth Plot on Channel 78

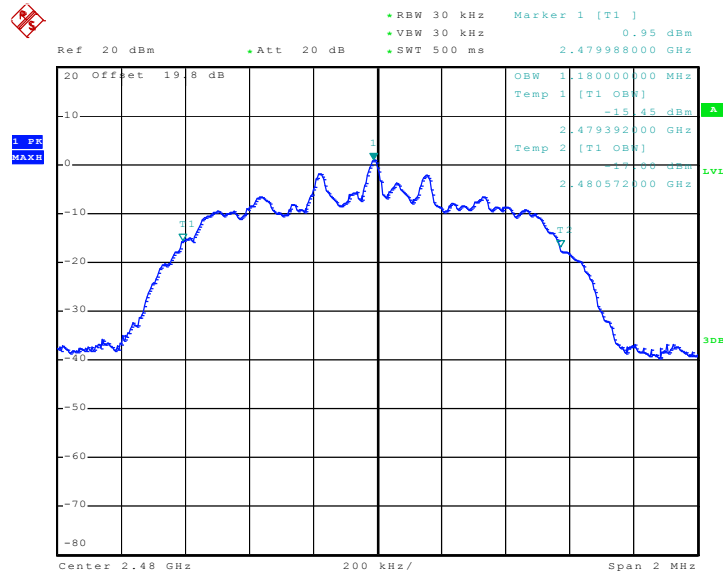

Date: 12.MAY.2009 15:46:08



Test Mode :	Mode 7, 8, 9	Temperature :	21~24°C
Test Engineer :	Ken Hsu	Relative Humidity :	41~45%

Channel	Frequency (MHz)	99% Occupied Bandwidth (MHz)
00	2402	1.200
39	2441	1.200
78	2480	1.192

99% Bandwidth Plot on Channel 00

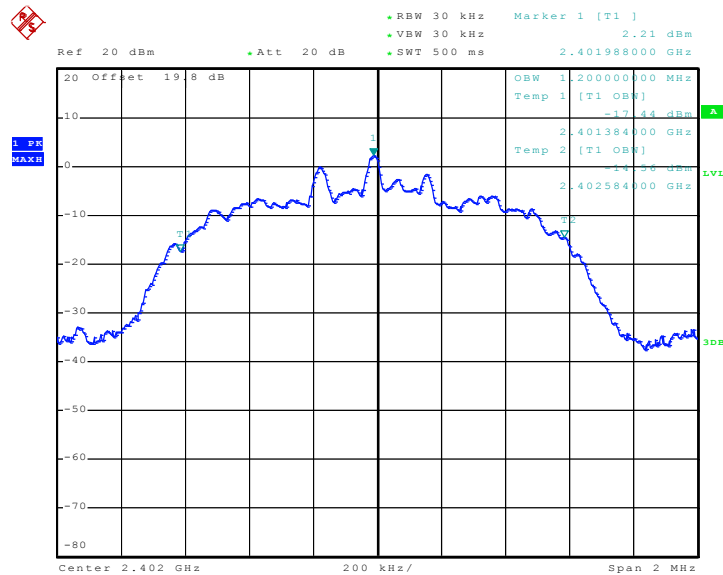

Date: 12.MAY.2009 15:46:43



99% Occupied Bandwidth Plot on Channel 39

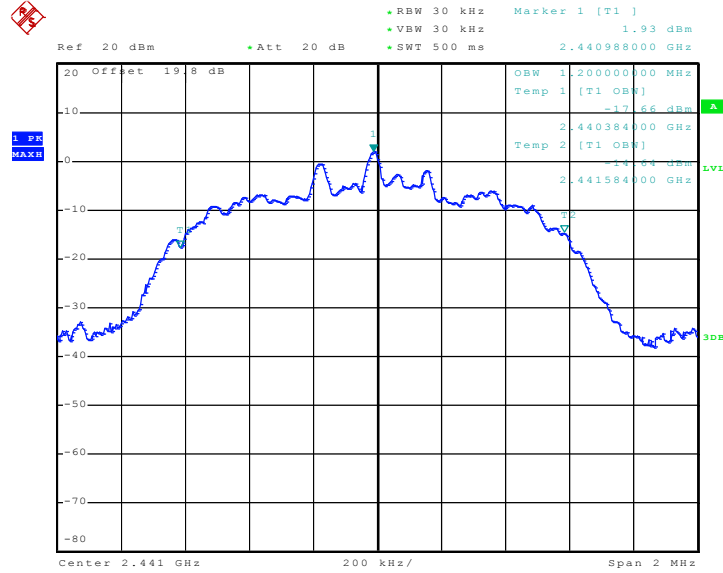

Date: 12.MAY.2009 15:48:28

99% Occupied Bandwidth Plot on Channel 78

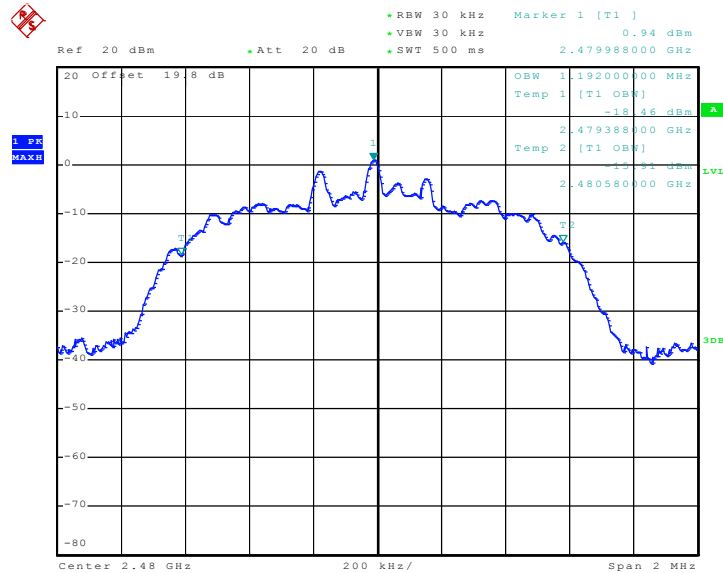

Date: 12.MAY.2009 15:49:02

3.3 Hopping Channel Separation Measurement

3.3.1 Limit of Hopping Channel Separation

Frequency hopping systems operating in the 2400-2483.5 MHz band may have hopping channel carrier frequencies that are separated by 25 kHz or two-thirds of the 20 dB bandwidth of the hopping channel, whichever is greater.

3.3.2 Measuring Instruments

See list of measuring instruments of this test report.

3.3.3 Test Procedures

1. Please refer FCC Public Notice DA 00-705 Measurement Guidelines.
2. The RF output of EUT was connected to the spectrum analyzer by a low loss cable.
3. The EUT should be transmitting at its maximum data rate as the worst cases.
4. Use the following spectrum analyzer settings:
Span = wide enough to capture the peaks of two adjacent channels; $RBW \geq 1\%$ of the span;
 $VBW \geq RBW$; Sweep = auto; Detector function = peak; Trace = max hold.
5. Use the marker-delta function to determine the separation between the peaks of the adjacent channels.

3.3.4 Test Setup

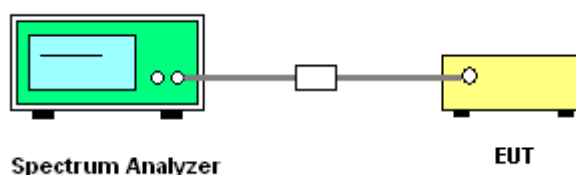



3.3.5 Test Result of Hopping Channel Separation

Test Mode :	Mode 7, 8, 9	Temperature :	21~24°C
Test Engineer :	Ken Hsu	Relative Humidity :	41~45%

Channel	Frequency (MHz)	Frequency Separation (MHz)	(2/3 of 20dB BW) Limits (MHz)	Pass/Fail
00	2402	1.000	0.859	Pass
39	2441	1.000	0.859	Pass
78	2480	1.000	0.856	Pass

Channel Separation Plot on Channel 00 - 01

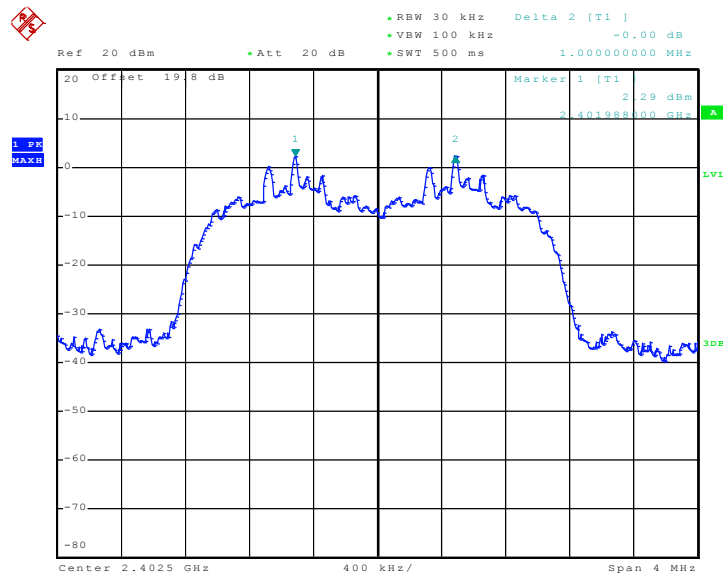

Date: 12.MAY.2009 16:09:04



Channel Separation Plot on Channel 39 - 40

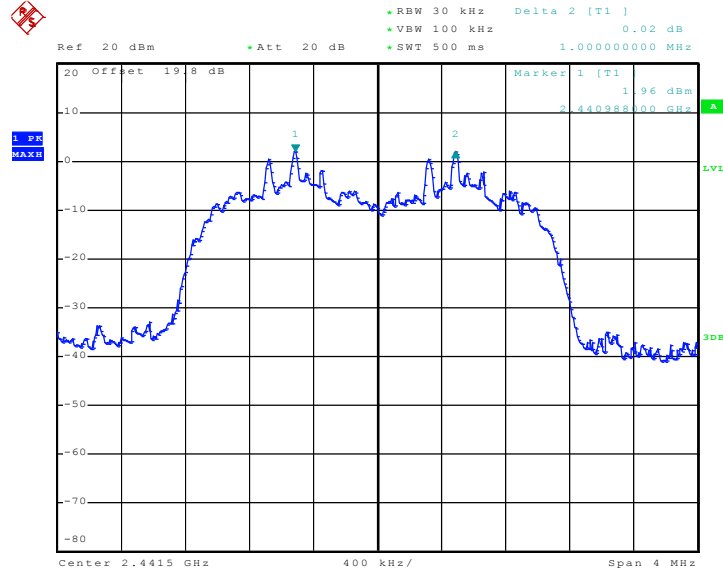

Date: 12.MAY.2009 16:09:46

Channel Separation Plot on Channel 77 - 78

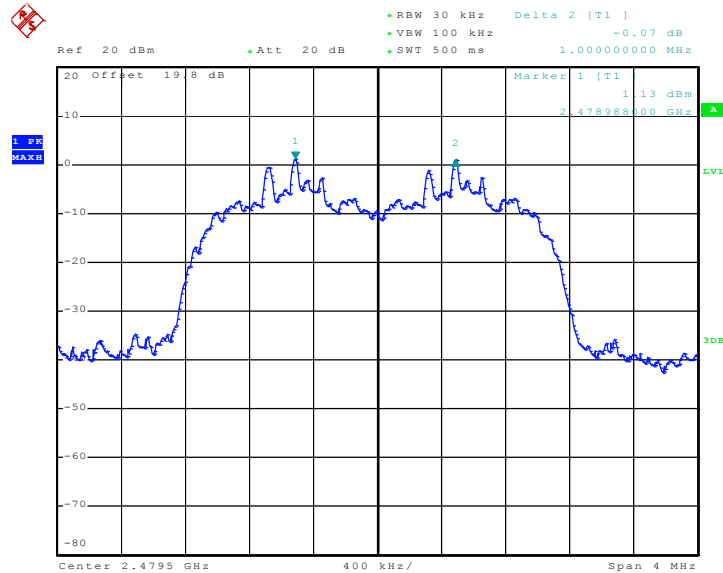

Date: 12.MAY.2009 16:14:10

3.4 Dwell Time Measurement

3.4.1 Limit of Dwell Time

The average time of occupancy on any channel shall not be greater than 0.4 seconds within a period of 0.4 seconds multiplied by the number of hopping channels employed.

3.4.2 Measuring Instruments

See list of measuring instruments of this test report.

3.4.3 Test Procedures

1. The testing follows FCC Public Notice DA 00-705 Measurement Guidelines.
2. The RF output of EUT was connected to the spectrum analyzer by a low loss cable.
3. The EUT should be transmitting at its maximum data rate as the worst cases.
4. The EUT must have its hopping function enabled. Use the following spectrum analyzer settings:
Span = zero span, centered on a hopping channel; RBW = 1 MHz; VBW ≥ RBW; Sweep = as necessary to capture the entire dwell time per hopping channel; Detector function = peak; Trace = max hold.
5. Use the marker-delta function to calculate the dwell time.

3.4.4 Test Setup

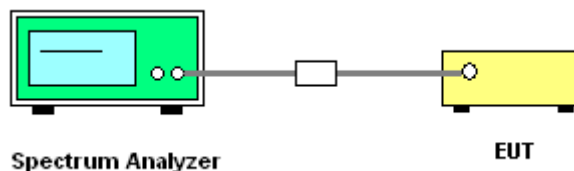

3.4.5 Test Result of Dwell Time

Test Mode :	Mode 8	Temperature :	21~24°C		
Test Engineer :	Ken Hsu	Relative Humidity :	41~45%		
Package Mode	Average Hopping Channel	Package Transfer Time (usec)	Dwell Time (sec)	Limits (sec)	Pass/Fail
3DH5	3.100	3098.00	0.303	0.4	Pass

Remark:

1. Dwell Time=79(channels) x 0.4(s) x average hopping channel x package transfer time
2. 79 channels come from the Hopping Channel number.
3. Average Hopping Channel = hops/sweep time
4. t: Package Transfer Time(us)



5.

3DH5 Dwell Time (One Pulse) Plot on Channel 39

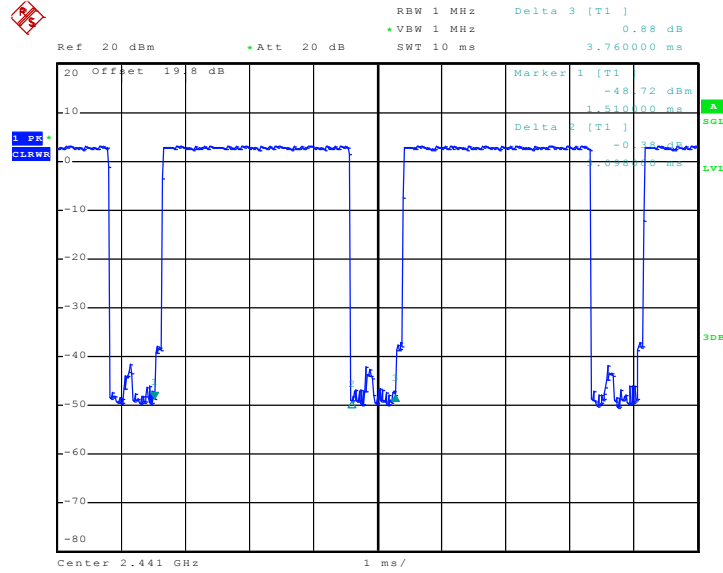

Date: 12.MAY.2009 11:21:16

3DH5 Dwell Time (Count Pulses) Plot on Channel 39

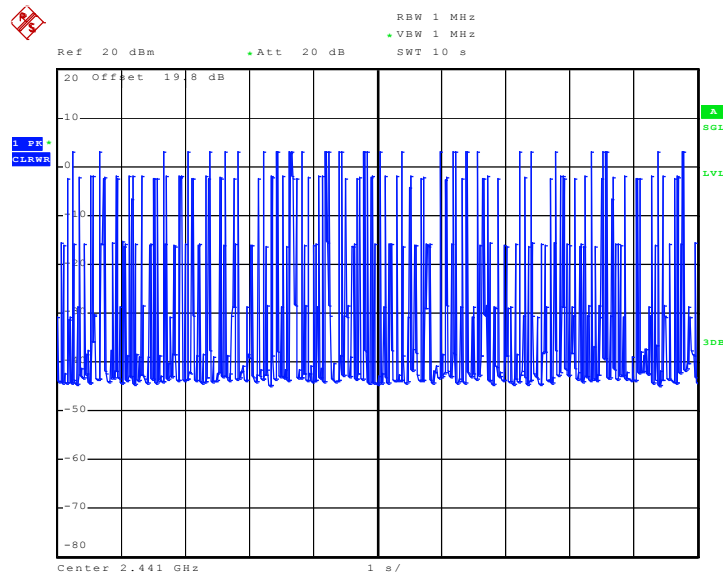

Date: 12.MAY.2009 11:26:41

3.5 Peak Output Power Measurement

3.5.1 Limit of Peak Output Power

Frequency hopping systems operating in the 2400-2483.5 MHz band employing at least 75 non-overlapping hopping channels: 1W (30 dBm).

3.5.2 Measuring Instruments

See list of measuring instruments of this test report.

3.5.3 Test Procedures

1. The testing follows FCC Public Notice DA 00-705 Measurement Guidelines.
2. The RF output of EUT was connected to the peak power meter by a low loss cable.

3.5.4 Test Setup

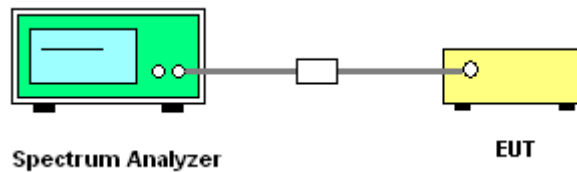

3.5.5 Test Result of Peak Output Power

Test Mode :	Mode 7, 8, 9	Temperature :	21~24°C
Test Engineer :	Ken Hsu	Relative Humidity :	41~45%

Channel	Frequency (MHz)	RF Power (dBm)		
		8-DPSK	Max. Limits (dBm)	Pass/Fail
		3 Mbps		
00	2402	3.95	30	Pass
39	2441	3.59	30	Pass
78	2480	2.53	30	Pass



Peak Output Power Plot on Channel 00

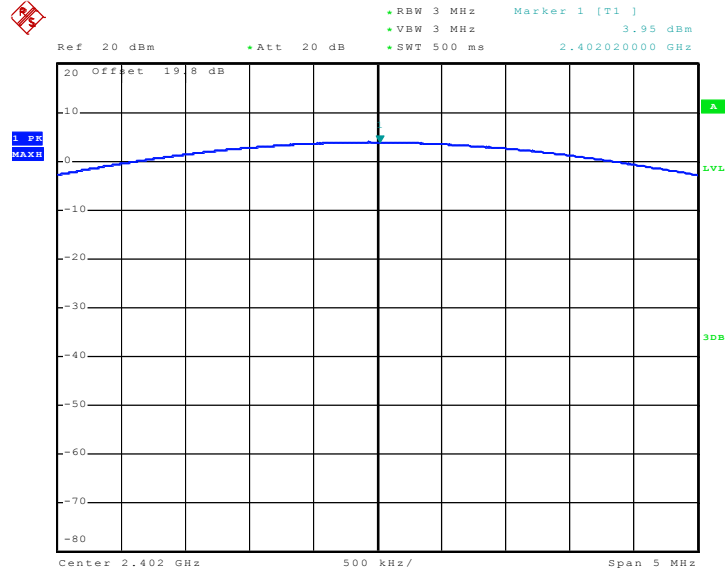

Date: 11.MAY.2009 17:14:28

Peak Output Power Plot on Channel 39

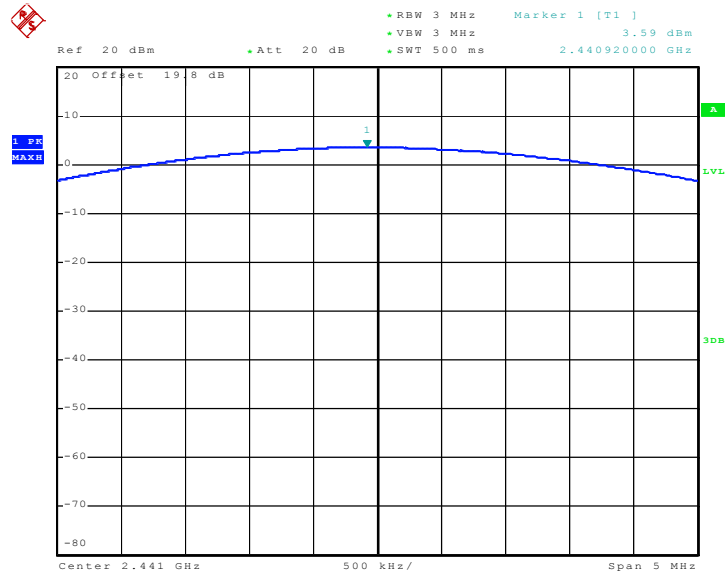

Date: 11.MAY.2009 17:15:54



Peak Output Power Plot on Channel 78

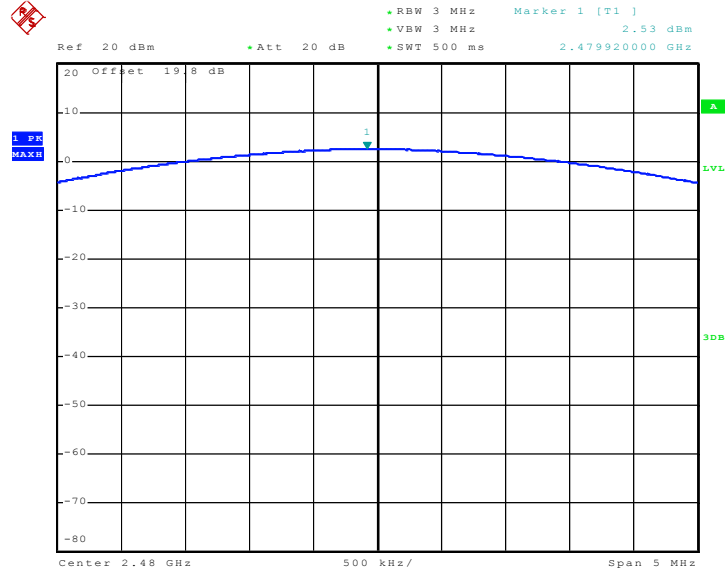

Date: 11.MAY.2009 17:17:40

3.6 Band Edges Measurement

3.6.1 Limit of Band Edges

In any 100 kHz bandwidth outside the intentional radiation frequency band, the radio frequency power shall be at least 20 dB below the highest level of the radiated power. In addition, radiated emissions which fall in the restricted bands must also comply with the radiated emission limits.

3.6.2 Measuring Instruments

See list of measuring instruments of this test report.

3.6.3 Test Procedures

1. The testing follows the guidelines in ANSI C63.4-2003 and FCC Public Notice DA 00-705 Measurement Guidelines.
2. RF antenna conducted test: Set RBW = 100 kHz, Video bandwidth (VBW) > RBW, scan up through 10th harmonic. Band edge emissions must be at least 20 dB down from the highest emission level within the authorized band as measured with a 100 kHz RBW. Note: If the device complies with the use of power option 2 the attenuation under this paragraph shall be 30 dB instead of 20 dB.
3. Radiated emission test: Applies to band edge emissions that fall in the restricted bands listed in FCC Section 15.205. The maximum permitted average field strength is listed in FCC Section 15.209. A pre-amp is necessary for this measurement. For measurements above 1 GHz, set RBW = 1MHz, VBW = 10 Hz, Sweep: Auto. If the emission is pulsed, modify the unit for continuous operation; use the settings shown above, then correct the reading by subtracting the peak-average correction factor, derived from the appropriate duty cycle calculation. See FCC Section 15.35(b) and (c).

3.6.4 Test Setup

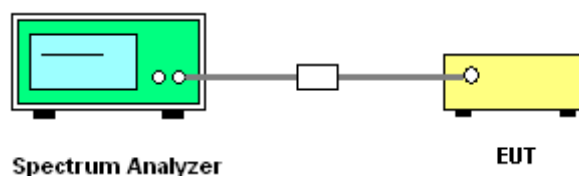



3.6.5 Test Result of Radiated Band Edges

Test Mode :	Mode 1	Temperature :	21~24°C
Test Channel :	00	Relative Humidity :	41~45%
		Test Engineer :	Kai Wang

ANTENNA POLARITY : HORIZONTAL										
Frequency (MHz)	Level (dBuV/m)	Over Limit (dB)	Limit Line (dBuV/m)	Read Level (dBuV)	Antenna Factor (dB)	Cable Loss (dB)	Preamp Factor (dB)	Ant Pos (cm)	Table Pos (deg)	Remark
2389.99	64.37	-9.63	74.00	64.75	31.98	3.92	36.28	100	231	Peak
2389.99	44.02	-9.98	54.00	44.40	31.98	3.92	36.28	100	231	Average

Remark:

<Delta Marker>

Delta marker at 1% RBW of span = 37.63 + 2.49 = 40.12 dB (can be referred to section 3.6.6)

Peak band edge at 2389.99 MHz (RBW = VBW = 1MHz) = 104.49 dBuV/m – 40.12 dB = 64.37 dBuV/m

Duty factor = 20 x log ((Package Transfer Times(ms) x Avg Hopping Channel) / 100 ms)

= 20 x log ((3.098 x 3.1) / 100) = -20.35

Average band edge = Peak band edge + Duty factor = 64.37 dBuV/m + (-20.35) = 44.02 dBuV/m

ANTENNA POLARITY : VERTICAL										
Frequency (MHz)	Level (dBuV/m)	Over Limit (dB)	Limit Line (dBuV/m)	Read Level (dBuV)	Antenna Factor (dB)	Cable Loss (dB)	Preamp Factor (dB)	Ant Pos (cm)	Table Pos (deg)	Remark
2388.85	57.72	-16.28	74.00	58.10	31.98	3.92	36.28	100	238	Peak
2388.85	37.37	-16.63	54.00	37.75	31.98	3.92	36.28	100	238	Average

Remark:

<Delta Marker>

Delta marker at 1% RBW of span = 37.63 + 2.49 = 40.12 dB (can be referred to section 3.6.6)

Peak band edge at 2388.85 MHz (RBW = VBW = 1MHz) = 97.84 dBuV/m – 40.12 dB = 57.72 dBuV/m

Duty factor = 20 x log ((Package Transfer Times(ms) x Avg Hopping Channel) / 100 ms)

= 20 x log ((3.098 x 3.1) / 100) = -20.35

Average band edge = Peak band edge + Duty factor = 57.72 dBuV/m + (-20.35) = 37.37 dBuV/m



Test Mode :	Mode 3	Temperature :	21~24°C
Test Channel :	78	Relative Humidity :	41~45%
		Test Engineer :	Kai Wang

ANTENNA POLARITY : HORIZONTAL										
Frequency (MHz)	Level (dBuV/m)	Over Limit (dB)	Limit Line (dBuV/m)	Read Level (dBuV)	Antenna Factor (dB)	Cable Loss (dB)	Preamp Factor (dB)	Ant Pos (cm)	Table Pos (deg)	Remark
2483.50	53.96	-20.04	74.00	54.13	32.08	4.05	36.30	100	233	Peak
2483.50	33.61	-20.39	54.00	33.78	32.08	4.05	36.30	100	233	Average

Remark:

<Delta Marker>

Delta marker at 1% RBW of span = 45.87 + 1.30 = 47.17 dB (can be referred to section 3.6.6)

Peak band edge at 2483.50 MHz (RBW = VBW = 1MHz) = 101.13 dBuV/m -47.17 dB = 53.96 dBuV/m

Duty factor = 20 x log ((Package Transfer Times(ms) x Avg Hopping Channel) / 100 ms)

$$= 20 \times \log ((3.098 \times 3.1) / 100) = -20.35$$

Average band edge = Peak band edge + Duty factor = 53.96 dBuV/m + (-20.35) dB = 33.61 dBuV/m

ANTENNA POLARITY : VERTICAL										
Frequency (MHz)	Level (dBuV/m)	Over Limit (dB)	Limit Line (dBuV/m)	Read Level (dBuV)	Antenna Factor (dB)	Cable Loss (dB)	Preamp Factor (dB)	Ant Pos (cm)	Table Pos (deg)	Remark
2483.50	49.36	-24.64	74.00	49.53	32.08	4.05	36.30	100	239	Peak
2483.50	29.01	-24.99	54.00	29.18	32.08	4.05	36.30	100	239	Average

Remark:

<Delta Marker>

Delta marker at 1% RBW of span = 45.87 + 1.30 = 47.17 dB (can be referred to section 3.6.6)

Peak band edge at 2483.50 MHz (RBW = VBW = 1MHz) = 96.53 dBuV/m -47.17 dB = 49.36 dBuV/m

Duty factor = 20 x log ((Package Transfer Times(ms) x Avg Hopping Channel) / 100 ms)

$$= 20 \times \log ((3.098 \times 3.1) / 100) = -20.35$$

Average band edge = Peak band edge + Duty factor = 49.36 dBuV/m + (-20.35) dB = 29.01 dBuV/m



3.6.6 Test Result of Conducted Band Edges

Test Mode :	Mode 7 and 9	Temperature :	21~24°C
Test Channel :	00 and 78	Relative Humidity :	41~45%
		Test Engineer :	Ken Hsu

Low Band Edge Plot on Channel 00

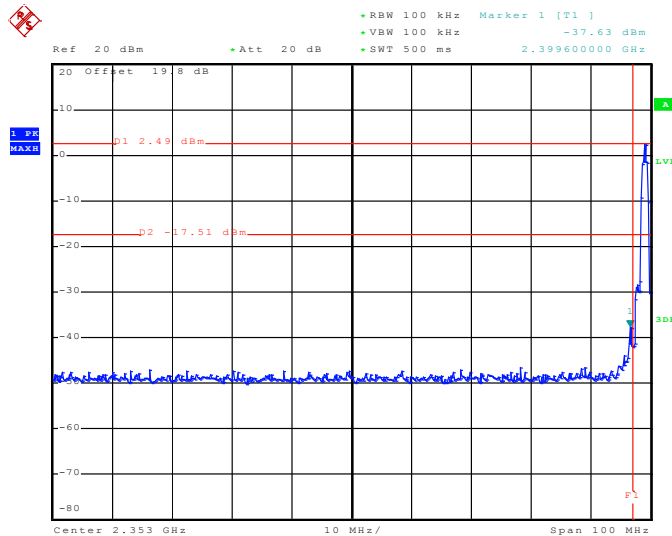

Date: 12.MAY.2009 15:57:46

High Band Edge Plot on Channel 78

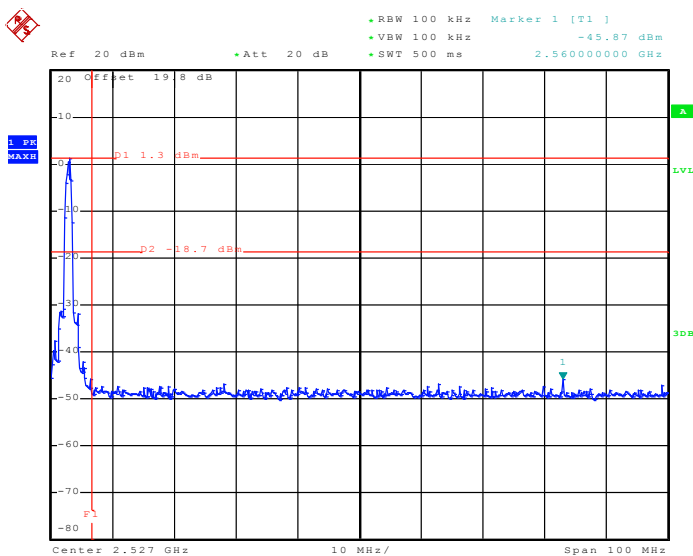

Date: 12.MAY.2009 15:58:15

3.7 Radiated Emission Measurement

3.7.1 Limit of Radiated Emission

In any 100 kHz bandwidth outside the intentional radiator frequency band, all harmonics/spurious must be at least 20 dB below the highest emission level within the authorized band. In addition, radiated emissions which fall in the restricted bands must also comply with the FCC section 15.209 limits as below.

Frequency (MHz)	Field Strength (microvolts/meter)	Measurement Distance (meters)
0.009 – 0.490	2400/F(kHz)	300
0.490 – 1.705	24000/F(kHz)	30
1.705 – 30.0	30	30
30 – 88	100	3
88 – 216	150	3
216 - 960	200	3
Above 960	500	3

3.7.2 Measuring Instruments

See list of measuring instruments of this test report.

3.7.3 Test Procedures

1. The testing follows the guidelines in FCC Public Notice DA 00-705 Measurement Guidelines.
2. Use the following spectrum analyzer settings:
Span = wide enough to fully capture the emission being measured; RBW = 1 MHz for $f \geq 1$ GHz, 100 kHz for $f < 1$ GHz; VBW \geq RBW; Sweep = auto; Detector function = peak; Trace = max hold.
3. Follow the guidelines in ANSI C63.4-2003 with respect to maximizing the emission by rotating the EUT, measuring the emission for three EUT orthogonal planes, and adjusting the measurement antenna height and polarization. A pre-amp and a high pass filter are used for this test in order to get the good signal level.

3.7.4 Test Setup

For radiated emissions below 30MHz

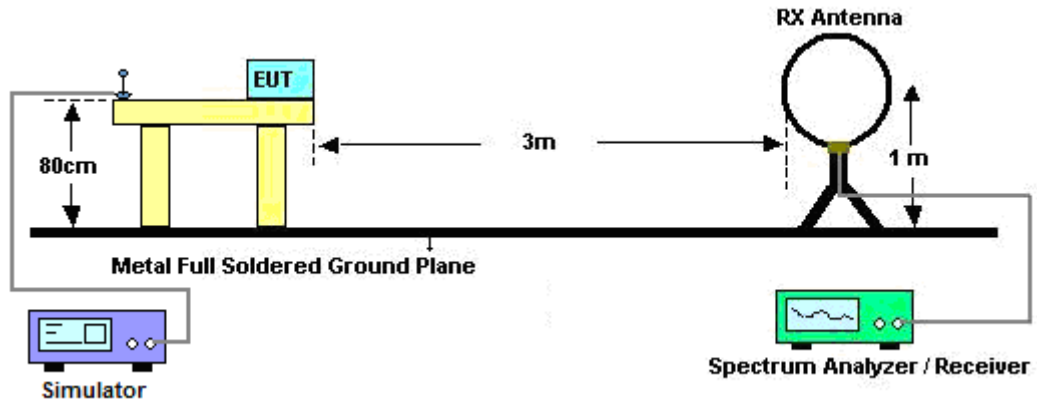

For radiated emissions above 30MHz

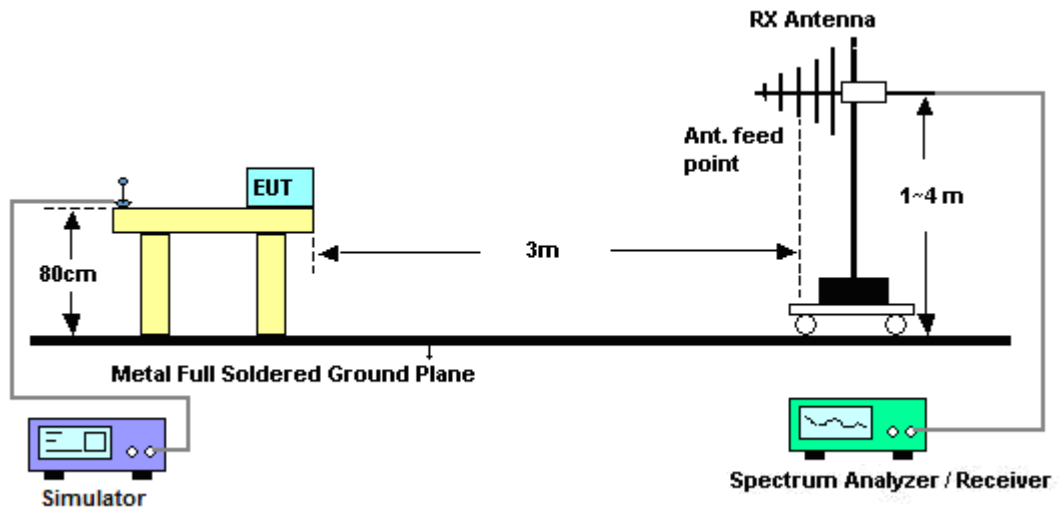



3.7.5 Test Results of Radiated Emissions (9kHz ~ 30MHz)

Test Engineer :	Kai Wang	Temperature :	21~24°C	
		Relative Humidity :	41~45%	
Frequency (MHz)	Level (dBuV)	Over Limit (dB)	Limit Line (dBuV)	Remark
-	-	-	-	See Note

Note:

The amplitude of spurious emissions that are attenuated by more than 20dB below the permissible value has no need to be reported.

Distance extrapolation factor = $40 \log(\text{specific distance} / \text{test distance})$ (dB);

Limit line = specific limits (dBuV) + distance extrapolation factor.



3.7.6 Test Result of Radiated Emission (30MHz ~ 10th Harmonic)

Test Mode :	Mode 1	Temperature :	21~24°C
Test Channel :	00	Relative Humidity :	41~45%
Test Engineer :	Kai Wang	Polarization :	Horizontal
Remark :	#11 and #12 are Fundamental Signals which can be ignored.		

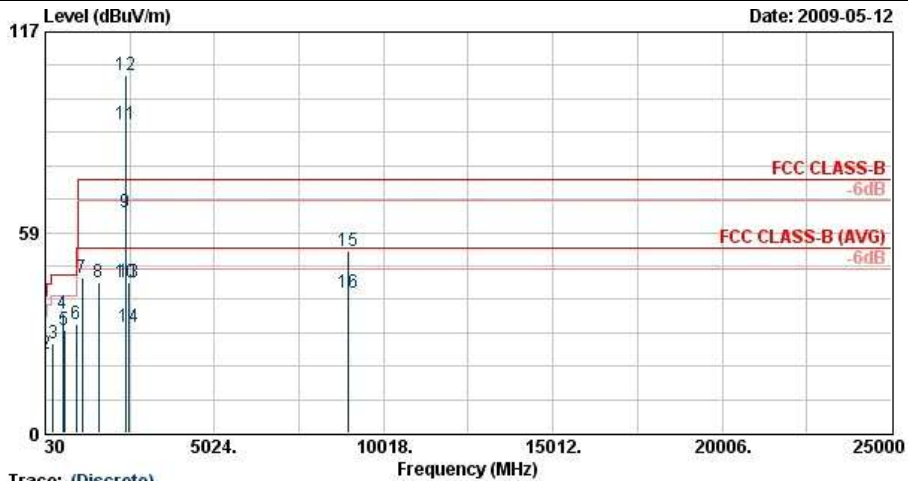

Trace: (Discrete)
 Site : 03CH06-HY
 Condition : FCC CLASS-B 3m SHF-EHF HORN HORIZONTAL
 Power : DC 24V
 Project : FR 950733
 Memo : Mode 1

	Freq	Level	Over	Limit	Read	Antenna	Cable	Preamp	Ant	Table	Remark
	MHz	dBUV/m	Limit	Line	Level	Factor	Loss	Factor	Pos	Pos	
			dB	dBUV/m	dBUV	dB/m	dB	dB	cm	deg	
1	30.00	21.30	-18.70	40.00	32.66	19.90	0.30	31.56	---	---	Peak
2	33.24	23.26	-16.74	40.00	36.58	18.10	0.30	31.72	---	---	Peak
3	257.34	26.25	-19.75	46.00	43.89	13.50	0.70	31.84	---	---	Peak
4	554.80	34.83	-11.17	46.00	47.04	18.92	1.00	32.13	100	139	Peak
5	586.30	29.81	-16.19	46.00	41.92	19.05	1.00	32.16	---	---	Peak
6	952.40	31.59	-14.41	46.00	39.65	22.11	1.23	31.39	---	---	Peak
7	1116.00	45.24	-28.76	74.00	51.97	27.92	2.37	37.03	100	0	Peak
8	1598.00	44.09	-29.91	74.00	48.91	28.70	2.93	36.45	100	0	Peak
9	2389.99	64.37	-9.63	74.00	64.75	31.98	3.92	36.28	100	231	Peak
10	2389.99	44.02	-9.98	54.00	44.40	31.98	3.92	36.28	100	231	Average
11 @	2402.00	89.95			90.33	31.98	3.92	36.28	100	231	Average
12 @	2402.00	104.49			104.85	32.00	3.92	36.28	100	231	Peak
13	2500.00	44.07	-29.93	74.00	44.22	32.10	4.05	36.30	100	231	Peak
14	2500.00	30.71	-23.29	54.00	30.86	32.10	4.05	36.30	100	231	Average
15	8967.00	52.86	-21.14	74.00	45.81	36.17	7.77	36.88	100	321	Peak
16	8967.00	40.68	-13.32	54.00	33.62	36.17	7.77	36.88	100	321	Average



Test Mode :	Mode 1	Temperature :	21~24°C
Test Channel :	00	Relative Humidity :	41~45%
Test Engineer :	Kai Wang	Polarization :	Vertical
Remark :	#10 and #11 are Fundamental Signals which can be ignored.		



Site :
Condition :
Power :
Project :
Memo :

Trace: (Discrete)
: 03CH06-HV
: FCC CLASS-B 3m SHF-EHF HORN VERTICAL
: DC 24V
: FR 950733
: Mode 1

	Freq	Level	Over	Limit	Read	Antenna	Cable	Preamp	Ant	Table	Remark
	MHz	dBuV/m	Limit	Line	Level	Factor	Loss	Factor	Pos	Pos	
			dB	dBuV/m	dBuV	dB/m	dB	dB	cm	deg	
1	30.00	24.16	-15.84	40.00	35.52	19.90	0.30	31.56	---	---	Peak
2 !	33.24	36.78	-3.22	40.00	50.10	18.10	0.30	31.72	100	103	QP
3	249.78	28.86	-17.14	46.00	47.15	12.80	0.70	31.79	---	---	Peak
4	329.40	29.05	-16.95	46.00	45.39	14.73	0.80	31.88	---	---	Peak
5	560.40	30.42	-15.58	46.00	42.61	18.94	1.00	32.13	---	---	Peak
6	586.30	33.94	-12.06	46.00	46.06	19.05	1.00	32.16	---	---	Peak
7	1094.00	42.60	-31.40	74.00	49.39	27.92	2.34	37.06	100	0	Peak
8	2388.85	57.72	-16.28	74.00	58.10	31.98	3.92	36.28	100	238	Peak
9	2388.85	37.37	-16.63	54.00	37.75	31.98	3.92	36.28	100	238	Average
10 X	2402.00	97.84			98.21	32.00	3.92	36.28	100	238	Peak
11 @	2402.00	84.30			84.68	31.98	3.92	36.28	100	238	Average
12	2494.00	44.08	-29.92	74.00	44.23	32.10	4.05	36.30	100	238	Peak
13	2494.00	30.44	-23.56	54.00	30.59	32.10	4.05	36.30	100	238	Average
14	7182.00	52.70	-21.30	74.00	46.39	35.62	7.16	36.47	100	173	Peak
15	7182.00	40.33	-13.67	54.00	34.02	35.62	7.16	36.47	100	173	Average



Test Mode :	Mode 2	Temperature :	21~24°C
Test Channel :	39	Relative Humidity :	41~45%
Test Engineer :	Kai Wang	Polarization :	Horizontal
Remark :	#11 and #12 are Fundamental Signals which can be ignored.		

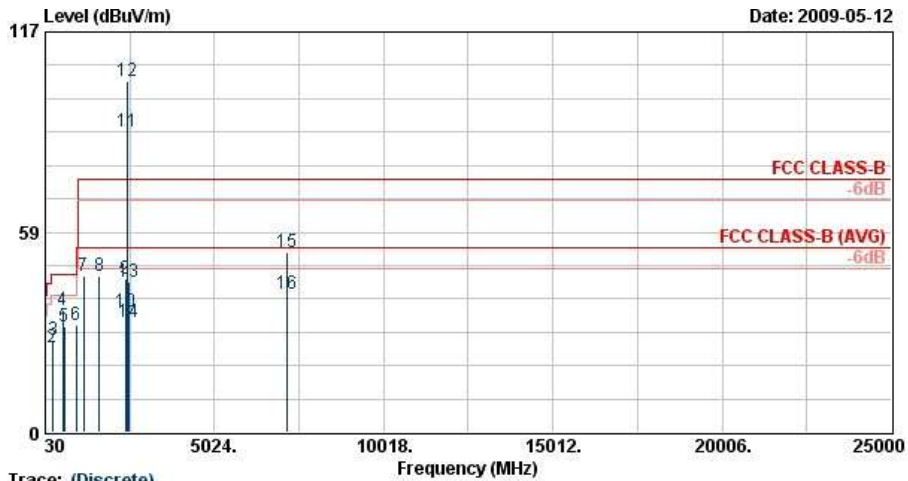

Trace: (Discrete)

Site : 03CH06-HV
 Condition : FCC CLASS-B 3m SHF-EHF HORN HORIZONTAL
 Power : DC 24V
 Project : FR 950733
 Memo : Mode 2

	Freq	Level	Over	Limit	Read	Antenna	Cable	Preamp	Ant	Table	Remark
	MHz	dBuV/m	dB	dBuV/m	dBuV	dB/m	dB	dB	cm	deg	
1	33.24	23.02	-16.98	40.00	36.34	18.10	0.30	31.72	---	---	Peak
2	239.79	24.82	-21.18	46.00	43.88	12.10	0.70	31.86	---	---	Peak
3	258.69	26.95	-19.05	46.00	44.40	13.70	0.70	31.85	---	---	Peak
4	554.80	35.55	-10.45	46.00	47.75	18.92	1.00	32.13	100	216	Peak
5	586.30	31.05	-14.95	46.00	43.17	19.05	1.00	32.16	---	---	Peak
6	952.40	31.49	-14.51	46.00	39.55	22.11	1.23	31.39	---	---	Peak
7	1174.00	45.55	-28.45	74.00	52.14	27.93	2.43	36.96	100	0	Peak
8	1628.00	45.56	-28.44	74.00	50.09	28.93	2.96	36.42	100	0	Peak
9	2388.00	44.67	-29.33	74.00	45.05	31.98	3.92	36.28	100	233	Peak
10	2388.00	35.30	-18.70	54.00	35.68	31.98	3.92	36.28	100	233	Average
11 @	2441.00	87.85			88.12	32.04	3.99	36.29	100	233	Average
12 X	2441.00	102.65			102.92	32.04	3.99	36.29	100	233	Peak
13	2500.00	44.11	-29.89	74.00	44.26	32.10	4.05	36.30	100	233	Peak
14	2500.00	32.35	-21.65	54.00	32.50	32.10	4.05	36.30	100	233	Average
15	7176.00	52.64	-21.36	74.00	46.33	35.63	7.15	36.47	100	281	Peak
16	7176.00	40.34	-13.66	54.00	34.03	35.63	7.15	36.47	100	281	Average



Test Mode :	Mode 2	Temperature :	21~24°C
Test Channel :	39	Relative Humidity :	41~45%
Test Engineer :	Kai Wang	Polarization :	Vertical
Remark :	#10 and #11 are Fundamental Signals which can be ignored.		

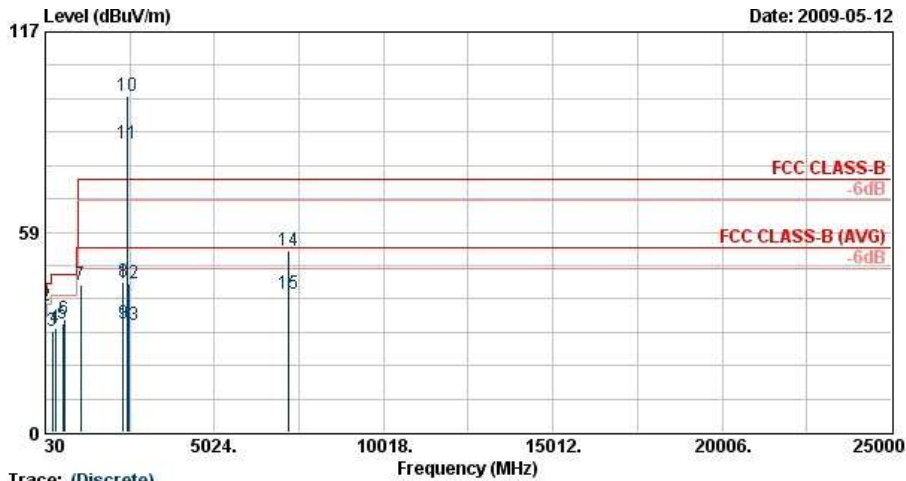

Trace: (Discrete)

Site : 03CH06-HY
 Condition : FCC CLASS-B 3m SHF-EHF HORN VERTICAL
 Power : DC 24V
 Project : FR 950733
 Memo : Mode 2

	Freq	Level	Over	Limit	Read	Antenna	Cable	Preamp	Ant	Table	Remark
	MHz	dBuV/m	Limit	Line	Level	Factor	Loss	Factor	Pos	Pos	
			dB	dBuV/m	dBuV	dB/m	dB	dB	cm	deg	
1	30.00	25.21	-14.79	40.00	36.57	19.90	0.30	31.56	---	---	Peak
2 !	33.24	36.81	-3.19	40.00	50.13	18.10	0.30	31.72	100	129	Peak
3	239.79	29.69	-16.31	46.00	48.75	12.10	0.70	31.86	---	---	Peak
4	330.80	30.46	-15.54	46.00	46.76	14.76	0.80	31.87	---	---	Peak
5	554.80	31.88	-14.12	46.00	44.09	18.92	1.00	32.13	---	---	Peak
6	586.30	33.07	-12.93	46.00	45.19	19.05	1.00	32.16	---	---	Peak
7	1078.00	43.26	-30.74	74.00	50.12	27.92	2.31	37.10	100	0	Peak
8	2326.00	43.91	-30.09	74.00	44.46	31.89	3.82	36.27	100	239	Peak
9	2326.00	31.69	-22.31	54.00	32.24	31.89	3.82	36.27	100	239	Average
10 X	2441.00	98.43			98.69	32.04	3.99	36.29	100	239	Peak
11 @	2441.00	84.49			84.76	32.04	3.99	36.29	100	239	Average
12	2494.00	43.43	-30.57	74.00	43.58	32.10	4.05	36.30	100	239	Peak
13	2494.00	31.10	-22.90	54.00	31.25	32.10	4.05	36.30	100	239	Average
14	7221.00	53.01	-20.99	74.00	46.72	35.61	7.17	36.49	100	126	Peak
15	7221.00	40.57	-13.43	54.00	34.28	35.61	7.17	36.49	100	126	Average



Test Mode :	Mode 3	Temperature :	21~24°C
Test Channel :	78	Relative Humidity :	41~45%
Test Engineer :	Kai Wang	Polarization :	Horizontal
Remark :	#11 and #12 are Fundamental Signals which can be ignored.		

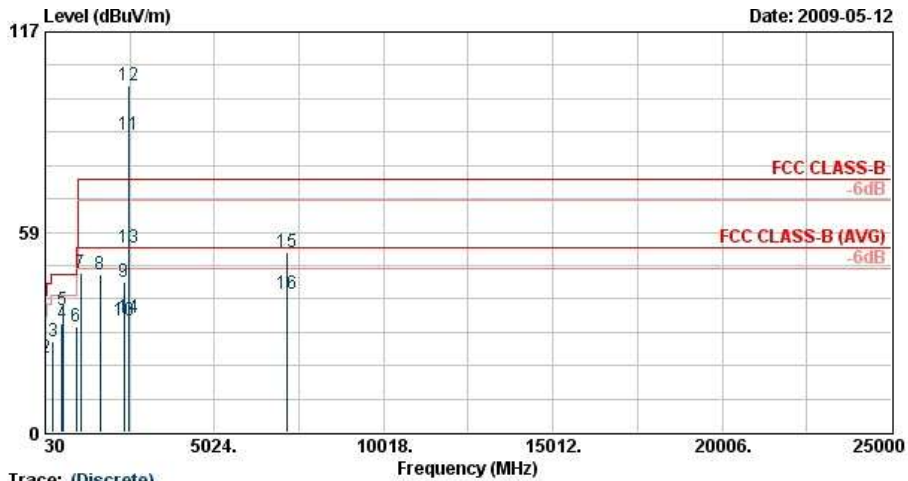

Trace: (Discrete)

Site : 03CH06-HY
 Condition : FCC CLASS-B 3m SHF-EHF HORN HORIZONTAL
 Power : DC 24V
 Project : FR 950733
 Memo : Mode 3

	Freq	Level	Over	Limit	Read	Antenna	Cable	Preamp	Ant	Table	Remark
	MHz	dBuV/m	dB	dBuV/m	dBuV	dB/m	dB	dB	cm	deg	
1	30.00	21.31	-18.69	40.00	32.67	19.90	0.30	31.56	---	---	Peak
2	33.24	21.85	-18.15	40.00	35.17	18.10	0.30	31.72	---	---	Peak
3	258.69	26.50	-19.50	46.00	43.95	13.70	0.70	31.85	---	---	Peak
4	521.90	31.66	-14.34	46.00	44.44	18.33	0.98	32.09	---	---	Peak
5	554.80	35.73	-10.27	46.00	47.93	18.92	1.00	32.13	100	183	Peak
6	950.30	30.87	-15.13	46.00	38.97	22.10	1.21	31.42	---	---	Peak
7	1078.00	46.74	-27.26	74.00	53.60	27.92	2.31	37.10	100	0	Peak
8	1652.00	46.26	-27.74	74.00	50.63	29.05	2.99	36.41	100	0	Peak
9	2350.00	43.79	-30.21	74.00	44.29	31.91	3.86	36.27	100	233	Peak
10	2350.00	32.73	-21.27	54.00	33.23	31.91	3.86	36.27	100	233	Average
11 @	2480.00	86.97			87.14	32.08	4.05	36.30	100	233	Average
12 X	2480.00	101.13			101.29	32.08	4.05	36.30	100	233	Peak
13	2483.50	53.96	-20.04	74.00	54.13	32.08	4.05	36.30	100	233	Peak
14	2483.50	33.61	-20.39	54.00	33.78	32.08	4.05	36.30	100	233	Average
15	7176.00	52.62	-21.38	74.00	46.31	35.63	7.15	36.47	100	106	Peak
16	7176.00	40.34	-13.66	54.00	34.03	35.63	7.15	36.47	100	106	Average



Test Mode :	Mode 3	Temperature :	21~24°C
Test Channel :	78	Relative Humidity :	41~45%
Test Engineer :	Kai Wang	Polarization :	Vertical
Remark :	#10 and #11 are Fundamental Signals which can be ignored.		

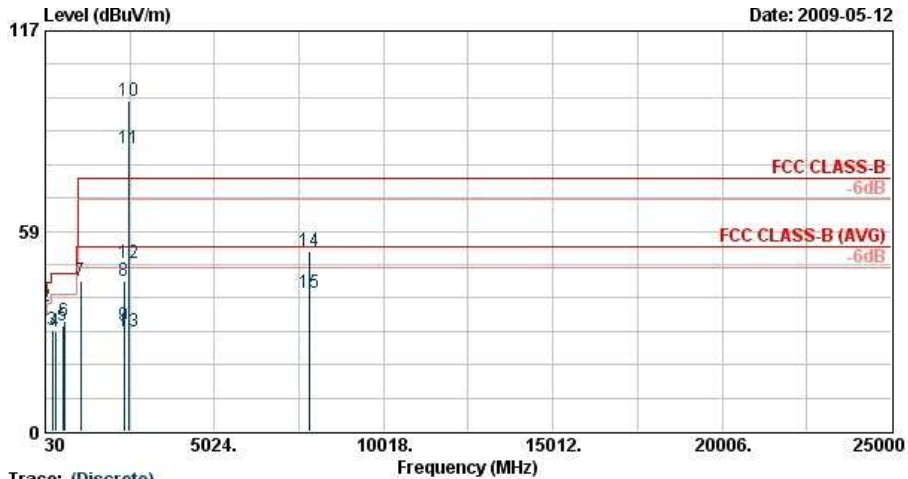

Site : 03CH06-HY
 Condition : FCC CLASS-B 3m SHF-EHF HORN VERTICAL
 Power : DC 24V
 Project : FR 950733
 Memo : Mode 3

	Freq	Level	Over	Limit	Read	Antenna	Cable	Preamp	Ant	Table	Remark
	MHz	dBuV/m	Limit	Line	Level	Factor	Loss	Factor	Pos	Pos	
			dB	dBuV/m	dBuV	dB/m	dB	dB	cm	deg	
1	30.00	25.97	-14.03	40.00	37.33	19.90	0.30	31.56	---	---	Peak
2 !	33.78	36.65	-3.35	40.00	50.62	17.50	0.30	31.78	100	129	Peak
3	241.68	29.65	-16.35	46.00	48.57	12.23	0.70	31.85	---	---	Peak
4	330.80	29.24	-16.76	46.00	45.54	14.76	0.80	31.87	---	---	Peak
5	554.80	30.96	-15.04	46.00	43.17	18.92	1.00	32.13	---	---	Peak
6	586.30	32.34	-13.66	46.00	44.45	19.05	1.00	32.16	---	---	Peak
7	1084.00	43.89	-30.11	74.00	50.73	27.92	2.34	37.10	100	0	Peak
8	2348.00	44.09	-29.91	74.00	44.59	31.91	3.86	36.27	100	239	Peak
9	2348.00	30.87	-23.13	54.00	31.37	31.91	3.86	36.27	100	239	Average
10 X	2480.00	96.53			96.69	32.08	4.05	36.30	100	239	Peak
11 X	2480.00	82.52			82.69	32.08	4.05	36.30	100	239	Average
12	2483.50	49.36	-24.64	74.00	49.53	32.08	4.05	36.30	100	239	Peak
13	2483.50	29.01	-24.99	54.00	29.18	32.08	4.05	36.30	100	239	Average
14	7836.00	52.77	-21.23	74.00	46.37	35.63	7.44	36.67	100	152	Peak
15	7836.00	40.54	-13.47	54.00	34.13	35.63	7.44	36.67	100	152	Average



3.8 Antenna Requirements

3.8.1 Standard Applicable

If directional gain of transmitting antennas is greater than 6dBi, the power shall be reduced by the same level in dB comparing to gain minus 6dBi.

The use of a permanently attached antenna or of an antenna that uses a unique coupling to the intentional radiator shall be considered sufficient to comply with the FCC rule.

3.8.2 Antenna Connected Construction

The antennas type used in this product is PCB Antenna without connector and it is considered to meet antenna requirement.

3.8.3 Antenna Gain

The antenna peak gain of EUT is less than 6 dBi. Therefore, it is not necessary to reduce maximum peak output power limit.



4 List of Measuring Equipment

Instrument	Manufacturer	Model No.	Serial No.	Characteristics	Calibration Date	Due Date	Remark
Spectrum Analyzer	R&S	FSP40	100055	9kHz~40GHz	Jun. 26, 2008	Jun. 25, 2009	Conducted (TH02-HY)
Power Meter	Agilent	E4416A	GB41292344	N/A	Feb. 19, 2009	Feb. 18, 2010	Conducted (TH02-HY)
Power Sensor	Agilent	E9327A	US40441548	N/A	Feb. 19, 2009	Feb. 18, 2010	Conducted (TH02-HY)
Spectrum Analyzer	Agilent	E4408B	MY44211030	9kHz~26.5GHz	Oct. 24, 2008	Oct. 23, 2009	Radiation (03CH06-HY)
Spectrum Analyzer	R&S	FSP40	100057	9kHz~40GHz	Oct. 16, 2008	Oct. 15, 2009	Radiation (03CH06-HY)
EMI Test Receiver	R&S	ESVS10	834468/003	20MHz~1000M Hz	Apr. 28, 2009	Apr. 27, 2010	Radiation (03CH06-HY)
Bilog Antenna	SCHAFFNER	CBL6112B	2885	30MHz~2GHz	Nov. 12, 2008	Nov. 11, 2009	Radiation (03CH06-HY)
Double Ridge Horn Antenna	EMCO	3117	00066583	1G~18GHz	Aug. 18, 2008	Aug. 17, 2009	Radiation (03CH06-HY)
Double Ridge Horn Antenna	Training Research	AF-0801	95119	8G~18G	Oct. 28, 2008	Oct. 27, 2009	Radiation (03CH06-HY)
SHF-EHF Horn	SCHWARZBECK	BBHA 9170	BBHA9170251	15G~40GHz	Oct. 16, 2008	Oct. 15, 2009	Radiation (03CH06-HY)
Pre Amplifier	Agilent	8449B	3008A01917	1G~26.5GHz	Nov. 11, 2008	Nov. 10, 2009	Radiation (03CH06-HY)
Pre Amplifier	Agilent	310N	186713	9kHz~1GHz	Apr. 20, 2009	Apr. 19, 2010	Radiation (03CH06-HY)
Loop Antenna	R&S	HFH2-Z2	860004/001	9 kHz~30 MHz	May 22, 2008	May 21, 2010	Radiation (03CH06-HY)
BT Base Station	Anritsu	MT8852B	6K00005722	N/A	Oct. 23, 2007	Oct. 22, 2009	Radiation (03CH06-HY)

5 Uncertainty of Evaluation

Uncertainty of Radiated Emission Measurement (30MHz ~ 1000MHz)

Contribution	Uncertainty of x_i		$u(x_i)$
	dB	Probability Distribution	
Receiver reading	0.41	Normal(k=2)	0.21
Antenna factor calibration	0.83	Normal(k=2)	0.42
Cable loss calibration	0.25	Normal(k=2)	0.13
Pre Amplifier Gain calibration	0.27	Normal(k=2)	0.14
RCV/SPA specification	2.50	Rectangular	0.72
Antenna Factor Interpolation for Frequency	1.00	Rectangular	0.29
Site imperfection	1.43	Rectangular	0.83
Mismatch	+0.39/-0.41	U-shaped	0.28
Combined standard uncertainty Uc(y)	1.27		
Measuring uncertainty for a level of confidence of 95% U=2Uc(y)	2.54		

Uncertainty of Radiated Emission Measurement (1GHz ~ 40GHz)

Contribution	Uncertainty of x_i		$u(x_i)$	C_i	$C_i * u(x_i)$
	dB	Probability Distribution			
Receiver reading	±0.10	Normal(k=1)	0.10	1	0.10
Antenna factor calibration	±1.70	Normal(k=2)	0.85	1	0.85
Cable loss calibration	±0.50	Normal(k=2)	0.25	1	0.25
Receiver Correction	±2.00	Rectangular	1.15	1	1.15
Antenna Factor Directional	±1.50	Rectangular	0.87	1	0.87
Site imperfection	±2.80	Triangular	1.14	1	1.14
Mismatch Receiver VSWR $\Gamma_1 = 0.197$ Antenna VSWR $\Gamma_2 = 0.194$ Uncertainty = $20 \log(1 - \Gamma_1 * \Gamma_2)$	+0.34/-0.35	U-shaped	0.244	1	0.244
Combined standard uncertainty Uc(y)	2.36				
Measuring uncertainty for a level of confidence of 95% U=2Uc(y)	4.72				

6 Certification of TAF Accreditation



Certificate No. : L1190-090417

財團法人全國認證基金會
Taiwan Accreditation Foundation

Certificate of Accreditation

This is to certify that

Sporton International Inc.
EMC & Wireless Communications Laboratory
No.52, Hwa Ya 1st Rd., Hwa Ya Technology Park, Kwei-Shan Hsiang, Tao Yuan Hsien,
Taiwan, R.O.C.

is accredited in respect of laboratory

Accreditation Criteria	: ISO/IEC 17025:2005
Accreditation Number	: 1190
Originally Accredited	: December 15, 2003
Effective Period	: January 10, 2007 to January 09, 2010
Accredited Scope	: Testing Field, see described in the Appendix
Specific Accreditation Program	: Accreditation Program for Designated Testing Laboratory for Commodities Inspection Accreditation Program for Telecommunication Equipment Testing Laboratory Accreditation Program for BSMI Mutual Recognition Arrangement with Foreign Authorities



Jay-San Chen
President, Taiwan Accreditation Foundation
Date : April 17, 2009

P1, total 20 pages

The Appendix forms an integral part of this Certificate, which shall be invalid when use without the Appendix



Appendix A. Photographs of EUT

Please refer to Sporton report number EP950733-01 as below.