

TEST REPORT

of

FCC Part 15 Subpart B & C

<Class II Permissive Change>

Product : **MOTONAV™ TN30**

Model(s): **SYN2847B**

Applicant: **Motorola, Inc.**

Address: **Mobile Devices**
600 N. U.S. Highway 45,
Libertyville, IL 60048-5343,
U. S. A.

Test Performed by:

International Standards Laboratory

<Lung-Tan LAB>

*Site Registration No.

BSMI: SL2-IN-E-0013; TAF: 0997; IC: IC4164-1 ;

VCCI: R-1435, C-1440, T-299, R-2598, C-2845; NEMKO: ELA 113B

*Address:

No. 120, Lane 180, San Ho Tsuen, Hsin Ho Rd.

Lung-Tan Hsiang, Tao Yuan County 325, Taiwan

*Tel : 886-3-407-1718; Fax: 886-3-407-1738

Report No.: **ISL-08LR040FCBT**

Issue Date : **2008/11/07**

Contents of Report

1.	General	1
1.1	Certification of Accuracy of Test Data	1
1.2	Test Results Summary	2
2.	Description of Equipment Under Test (EUT)	3
3.	Description of Support Equipment	4
3.1	Description of Support Equipment	4
3.1.1	Software for Controlling Support Unit	4
3.1.2	I/O Cable Condition of EUT and Support Units	4
4.	TEST RESULTS (Bluetooth)	5
4.1	Powerline Conducted Emissions	5
4.1.1	EUT Configuration	5
4.1.2	Test Procedure	5
4.1.3	EMI Receiver/Spectrum Analyzer Configuration (for the frequencies tested)	5
4.1.4	Test Data:	5
4.2	FHSS Maximum Peak Output Power	6
4.2.1	Test Procedure	6
4.2.2	Test Setup	6
4.2.3	Test Data	6
4.3	Radiated Emission Measurement	8
4.3.1	EUT Configuration	8
4.3.2	Test Procedure	8
4.3.3	EMI Receiver/Spectrum Analyzer Configuration (for the frequencies tested)	8
4.3.4	Test Data (30MHz – 1GHz):	9
4.3.5	Test Data (1GHz – 25 GHz)	11
4.4	Band Edge Measurement	17
4.4.1	Test Procedure	17
4.4.2	Test Setup	17
4.4.3	Test Data:	18
4.5.1	Test Procedure (Radiated)	21
4.5.2	Test Setup (Radiated)	21
4.5.3	Test Data	22
4.6	Bandwidth & Hopping Channel Separation	25
4.6.1	Standard Applicable	25
4.6.2	Test Procedure	25
4.6.3	Test Setup	25
4.6.4	Test Data	26
4.7	Number of Hopping Frequency Used	30
4.7.1	Test Procedure	30
4.7.2	Test Setup	30
4.7.3	Test Data	30
4.8	Dwell Time	32
4.8.1	Test Procedure	32
4.8.2	Test Setup	32
4.8.3	Test Data	33



5. Appendix 39

5.1 Appendix A: Measurement Procedure for Power line Conducted Emissions..... 39

5.2 Appendix B: Test Procedure for Radiated Emissions 40

5.3 Appendix C: Test Equipment 41

5.3.1 Test Equipment List..... 41

5.3.2 Software for Controlling Spectrum/Receiver and Calculating Test Data 41

5.4 Appendix D: Layout of EUT and Support Equipment 42

5.4.1 General Conducted Test Configuration 42

5.4.2 General Radiation Test Configuration..... 43

5.5 Appendix E: Accuracy of Measurement 44

5.6 Appendix F: Photographs of EUT Configuration Test Set Up..... 45

5.7 Appendix G: Antenna Spec. 46

1. General

1.1 Certification of Accuracy of Test Data

Standards: CFR 47 Part 15 Subpart B Class B
CFR 47 Part 15 Subpart C (Section 15.247)

Test Procedure: ANSI C63.4:2003

Equipment Tested: MOTONAV™ TN30

Model: SYN2847B

Applied by: Motorola, Inc.

Sample received Date: 2008/07/15

Final test Date : 2008/07/15-2008/07/22

Test Result PASS

Test Site: Chamber 02

Temperature Refer to each site test data

Humidity: Refer to each site test data

Test Engineer:

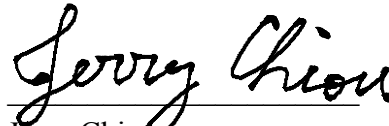
Jerry Chiou

All the tests in this report have been performed and recorded in accordance with the standards described above and performed by an independent electromagnetic compatibility consultant, International Standards Laboratory.

The test results contained in this report accurately represent the measurements of the characteristics and the energy generated by sample equipment under test at the time of the test. The sample equipment tested as described in this report is in compliance with the limits of above standards.

Approve & Signature

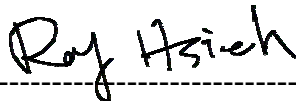

Roy Hsieh / Manager

Test results given in this report apply only to the specific sample(s) tested under stated test conditions. This report shall not be reproduced other than in full without the explicit written consent of ISL. This report totally contains 49 pages, including 1 cover page, 2 contents page, and 46 pages for the test description.

1.2 Test Results Summary

The Bluetooth functions of EUT has been tested according to the FCC regulations listed below:

Tested Standards: 47 CFR Part 15 Subpart C			
Standard Section	Test Type	Result	Remarks
15.207(a)	AC Power Line Emissions	NA	
15.247(b) (1)	Max. Peak Output Power	Pass	
15.209(a)	Radiated Emissions 30MHz – 25 GHz	Pass	
15.247 (c)	Band Edge Measurement	Pass	
15.247(a)(1)(iii)	Number of Hopping Frequency Used	Pass	
15.247(a) (1)(ii)	Spectrum Bandwidth Of FHSS device	Pass	
15.247(a)(1)	Hopping Channel Separation	Pass	
15.247(a)(1)(iii)	Dwell Time	Pass	

2. Description of Equipment Under Test (EUT)

Description:	MOTONAV™ TN30
Condition:	Pre-Production
Model:	SYN2847B
Brand:	Motorola
Frequency Range	2400 - 2483.5 MHz
Support channel:	
Bluetooth:	79 Channels
Modulation Skill:	
Bluetooth:	GFSK(1Mbps)
Antennas Type:	
Bluetooth:	Printed on PCB
Antenna Connected:	The antenna printed on the PCB of the Bluetooth module .The user is not possible to change the antenna without disassembling the EUT.
Antenna peak Gain:	
Bluetooth:	0.08 dBi
Power Type of BT module:	3.3V DC from Rechargeable Battery
DC power supply:	
Car Charger	Motorola (Model:SYN2826A)

The channels and the operation frequency of Bluetooth listed below:

Channel	Frequency(MHz)	Channel	Frequency(MHz)
00	2402	01	2403
02	2404	03	2405
04	2406	05	2407
.....			
75	2477	76	2478
77	2479	78	2480

Power Key :	One
Reset Key :	One
USB/ DC-In port :	One
SD Slot:	One
Battery :	Sanyo (Model : T0052) 3.7V/1100mAh

This report is a class II change of **FCC ID: IHDP6JU1** granted on 07/31/2008. The reasons of change are 1) update a new version of the operating system, 2) change the model number to SYN2847B. Due to they don't change the RF characteristics, we present the same test data of the original test report.

3. Description of Support Equipment

3.1 Description of Support Equipment

None

3.1.1 Software for Controlling Support Unit

Test programs exercising various part of EUT were used. The programs were executed as follows:

- A. The Bluetooth Connectivity Test Set link with EUT (execute the software) to makes the transmitter continuously sending RF signals .

	Filename	Issued Date
Bluetooth	nF2103CEtest.exe	08/02/2007

3.1.2 I/O Cable Condition of EUT and Support Units

Description	Path	Cable Length	Cable Type	Connector Type
DC Power Cord	DC 12V to EUT USB Port	1.5M	Non-shielded, Detachable	Plastic Head

4. TEST RESULTS (Bluetooth)

4.1 Powerline Conducted Emissions

4.1.1 EUT Configuration

The EUT was set up on the non-conductive table that is 1.0 by 1.5 meter, 80cm above ground. The wall of the shielded room was located 40cm to the rear of the EUT.

Power to the EUT was provided through the LISN. The impedance vs. frequency characteristic of the LISN is complied with the limit used.

Both lines (neutral and hot) were connected to the LISN in series at testing. A coaxial-type connector which provides one 50 ohms terminating impedance was provided for connecting the test instrument. The excess length of the power cord was folded back and forth at the center of the lead so as to form a bundle not exceeding 40cm in length.

Any changes made to the configuration, or modifications made to the EUT, during testing are noted in the following test record.

If the EUT is a Personal Computer or a peripheral of personal computer, and the personal computer has an auxiliary AC outlet which can be used for providing power to an external monitor, then all measurements will be made with the monitor power from first the computer-mounted AC outlet and then a floor-mounted AC outlet.

4.1.2 Test Procedure

The system was set up as described above, with the EMI diagnostic software running. The main power line conducted EMI tests were run on the hot and neutral conductors of the power cord and the results were recorded. The effect of varying the position of the interface cables has been investigated to find the configuration that produces maximum emission.

At the frequencies where the peak values of the emissions were higher than 6dB below the applicable limits, the emissions were also measured with the quasi-peak detectors. At the frequencies where the quasi-peak values of the emissions were higher than 6dB below the applicable average limits, the emissions were also measured with the average detectors.

The highest emissions were analyzed in details by operating the spectrum analyzer in fixed tuned mode to determine the nature of the emissions and to provide information which could be useful in reducing their amplitude.

4.1.3 EMI Receiver/Spectrum Analyzer Configuration (for the frequencies tested)

Frequency Range	150 KHz--30MHz
Detector Function	Quasi-Peak/Average
Bandwidth (RBW)	9KHz

4.1.4 Test Data:

<Not required>

4.2 FHSS Maximum Peak Output Power

4.2.1 Test Procedure

The Transmitter output of EUT was connected to the spectrum analyzer.

4.2.2 Test Setup

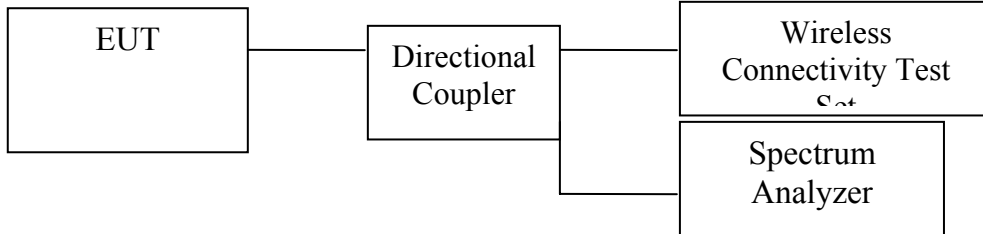

4.2.3 Test Data

Maximum Peak Output Power

Temperature (°C):27

Humidity (%):65

Test Engineer:Jerry Chiou

Channel	Frequency (Mhz)	Analyzer Reading (dBm)	Cable Loss (dB)	Peak Power Output (mW)	Peak Power Output (dBm)	Limit (dBm)	Pass/Fail
00	2402	-0.25	1.10	1.22	0.85	30	Pass
39	2441	-0.20	1.10	1.23	0.90	30	Pass
78	2480	-1.22	1.10	0.97	-0.12	30	Pass

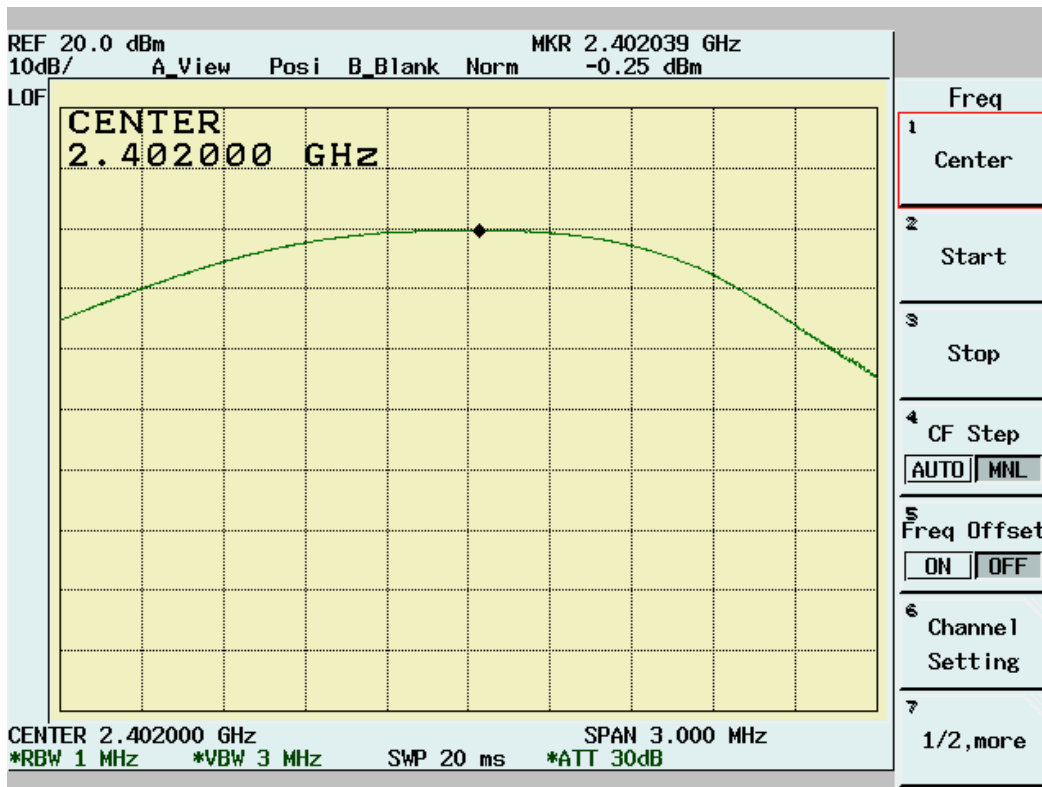

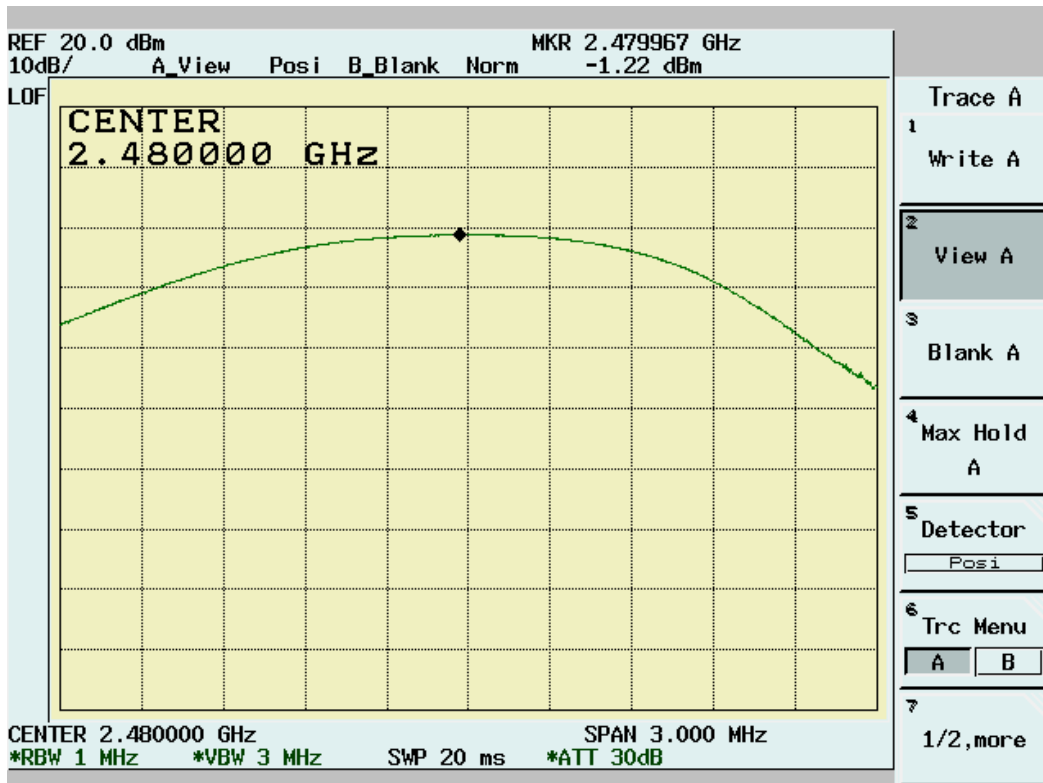
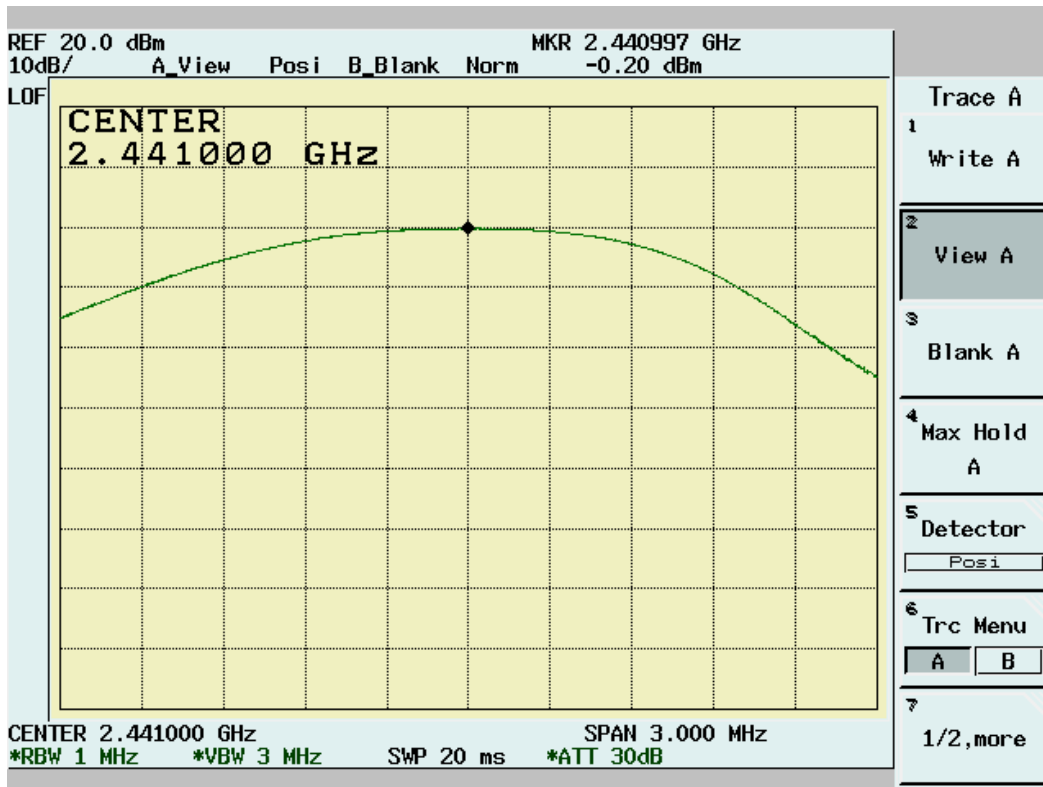

4.3 Radiated Emission Measurement

4.3.1 EUT Configuration

The equipment under test was set up on the 10 meter chamber with measurement distance of 3 meters. The EUT was placed on a non-conductive table 80cm above ground.

Any changes made to the configuration, or modifications made to the EUT, during testing are noted in the following test record.

4.3.2 Test Procedure

The system was set up as described above, with the EMI diagnostic software running. We found the maximum readings by varying the height of antenna and then rotating the turntable. Both polarization of antenna, horizontal and vertical, are measured.

30M to 1GHz: The highest emissions between 30 MHz to 1000 MHz were also analyzed in details by operating the spectrum analyzer and/or EMI receiver in quasi-peak mode to determine the precise amplitude of the emissions. While doing so, the interconnecting cables and major parts of the system were moved around, the antenna height was varied between one and four meters, its polarization was varied between vertical and horizontal, and the turntable was slowly rotated, to maximize the emission.

1GHz – 25GHz: The highest emissions were also analyzed in details by operating the spectrum analyzer and/or EMI receiver in peak mode to determine the precise amplitude of the emission. While doing so, the interconnecting cables and major parts of the system were moved around, the antenna height was varied between one and four meters, its polarization was varied between vertical and horizontal, and the turntable was slowly rotated, to maximize the emission. During test the EMI receiver and spectrum was setup according to EMI Receiver/Spectrum Analyzer Configuration.

For the test of 2nd to 10th harmonics frequencies, the equipment setup was also referred to EMI Receiver/Spectrum Analyzer Configuration. The frequencies were tested using Peak mode first, if the test data is higher than the emissions limit, an additional measurement using Average mode will be performed and the average reading will be compared to the limit and record in test report.

4.3.3 EMI Receiver/Spectrum Analyzer Configuration (for the frequencies tested)

Frequency Range Tested:	30MHz~1000MHz
Detector Function:	Quasi-Peak Mode
Resolution Bandwidth (RBW):	120KHz
Video Bandwidth (VBW)	1MHz

Frequency Range Tested:	1GHz – 25 GHz
Detector Function:	Peak Mode
Resolution Bandwidth (RBW):	1MHz
Video Bandwidth (VBW)	3MHz

Frequency Range Tested:	1GHz – 25 GHz
Detector Function:	Average Mode
Resolution Bandwidth (RBW):	1MHz
Video Bandwidth (VBW)	1KHz

4.3.4 Test Data (30MHz – 1GHz):

30M – 1GHz Open Field Radiated Emissions (Horizontal) Channel 00, 39, 78

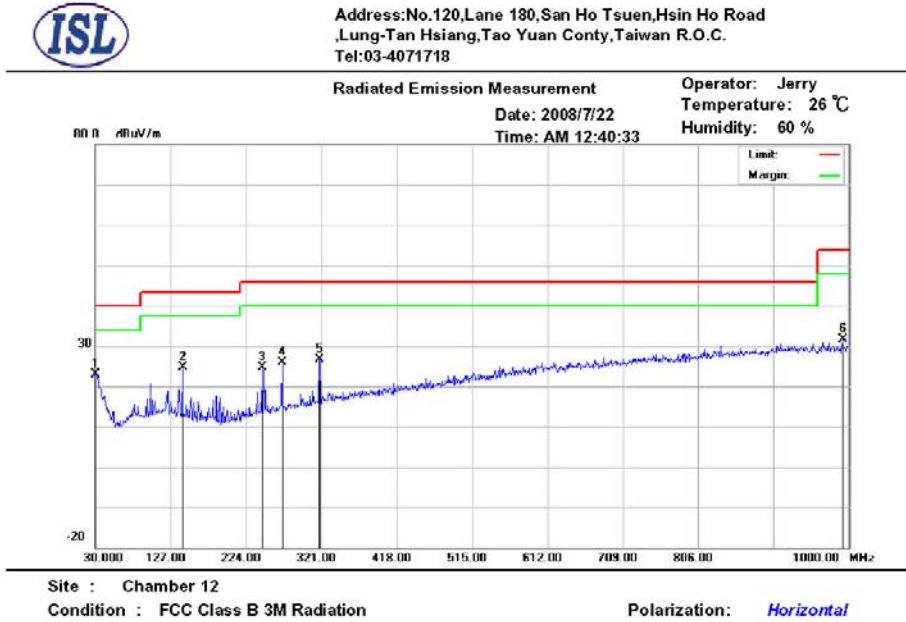

Mk.	Frequency (MHz)	RX_R (dBuV/m)	Ant_F (dB)	Cab_L (dB)	PreAmp (dB)	Emission (dBuV/m)	Limit (dBuV/m)	Margin (dB)	Ant.Pos (cm)	Tab.Pos (deg.)	Detector
*	30.9700	3.32	18.5	1.06	0	22.88	40.00	-17.12	100	51	peak
	142.5200	14.20	7.96	2.4	0	24.56	43.50	-18.94	282	8	peak
	245.3400	12.54	9.1	2.95	0	24.59	46.00	-21.41	339	107	peak
	270.5600	12.77	9.94	3.11	0	25.82	46.00	-20.18	283	104	peak
	319.0600	11.73	11.44	3.41	0	26.58	46.00	-19.42	100	225	peak
	992.2400	4.42	21.3	5.88	0	31.60	54.00	-22.40	100	147	peak

*:Maximum data x:Over limit !:over margin

30M – 1GHz Open Field Radiated Emissions (Vertical) Channel 00, 39, 78



Address: No.120, Lane 180, San Ho Tsuen, Hsin Ho Road
.Lung-Tan Hsiang, Tao Yuan Conty, Taiwan R.O.C.
Tel: 03-4071718

Radiated Emission Measurement

Date: 2008/7/22
Time: AM 12:43:39

Operator: Jerry
Temperature: 26 °C
Humidity: 60 %

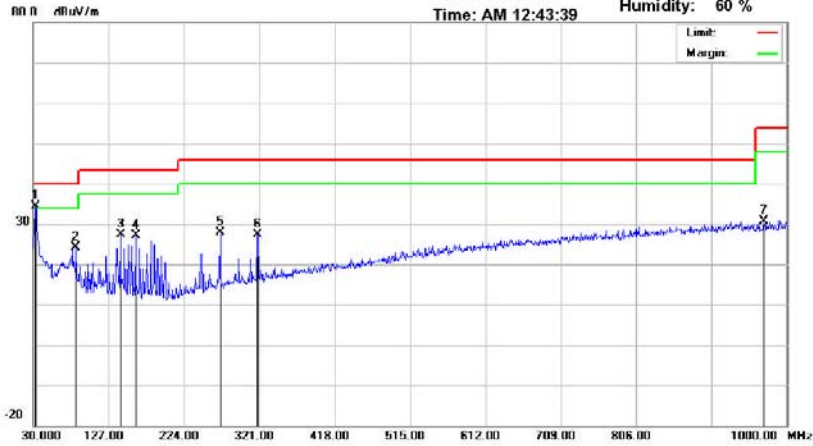

Site : Chamber 12

Condition : FCC Class B 3M Radiation

Polarization: Vertical

Mk.	Frequency (MHz)	RX_R (dBuV/m)	Ant_F (dB)	Cab_L (dB)	PreAmp (dB)	Emission (dBuV/m)	Limit (dBuV/m)	Margin (dB)	Ant.Pos (cm)	Tab.Pos (deg.)	Detector
*	32.9100	15.61	17.56	1.17	0	34.34	40.00	-5.66	118	159	peak
	85.2900	13.79	8.44	1.95	0	24.18	40.00	-15.82	240	245	peak
	142.5200	17.11	7.96	2.4	0	27.47	43.50	-16.03	321	212	peak
	161.9200	17.49	7.19	2.52	0	27.20	43.50	-16.30	100	87	peak
	270.5600	14.79	9.94	3.11	0	27.84	46.00	-18.16	242	283	peak
	319.0600	12.51	11.44	3.41	0	27.36	46.00	-18.64	388	345	peak
	970.9000	3.80	21.08	5.84	0	30.72	54.00	-23.28	371	223	peak

*:Maximum data x:Over limit !:over margin

NOTE:

- During the Pre-test, the EUT has been tested for Channel 00, 39, 78 transmit from Main and Aux antenna respectively to get all the critical emission frequencies. In the final test all the critical emission frequencies has been tested and the test data are listed above.

- Margin = Corrected Amplitude – Limit

Corrected Amplitude = Radiated Amplitude + Antenna Correction Factor + Cable Loss - Pre-Amplifier Gain

A margin of -8dB means that the emission is 8dB below the limit

All frequencies from 30MHz to 1GHz have been tested

4.3.5 Test Data (1GHz – 25 GHz)

1GHz~ 25 GHz (Horizontal), Channel 00: 2402 MHz

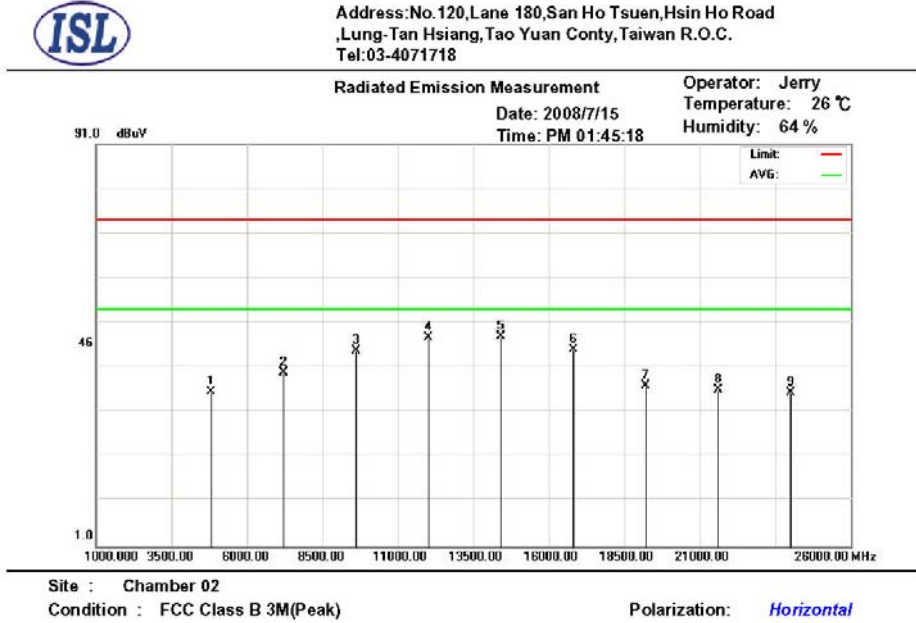

Mk.	Frequency (MHz)	RX_R (dBuV)	Ant_F (dB)	Cab_L (dB)	PreAmp (dB)	Emission (dBuV)	Limit (dBuV)	Margin (dB)	Ant.Pos (cm)	Tab.Pos (deg.)	Detector
	4804.000	29.54	33.55	2.83	30.46	35.46	74.00	-38.54	316	135	peak
	7206.000	29.28	38.04	3.37	30.89	39.80	74.00	-34.20	200	180	peak
	9608.000	28.87	40.08	3.99	28.26	44.68	74.00	-29.32	100	14	peak
	12010.000	33.20	41.71	4.47	31.8	47.58	74.00	-26.42	219	232	peak
*	14412.000	31.21	43.44	4.85	31.5	48.00	74.00	-26.00	252	83	peak
	16814.000	28.70	41.77	5.38	30.95	44.90	74.00	-29.10	100	52	peak
	19216.000	28.60	32.39	5.66	29.8	36.85	74.00	-37.15	324	302	peak
	21618.000	24.58	33.1	6.02	27.7	36.00	74.00	-38.00	391	187	peak
	24020.000	23.88	33.31	5.87	27.73	35.33	74.00	-38.67	107	108	peak

*:Maximum data x:Over limit !:over margin

1GHz~ 25 GHz (Vertical), Channel 00: 2402 MHz

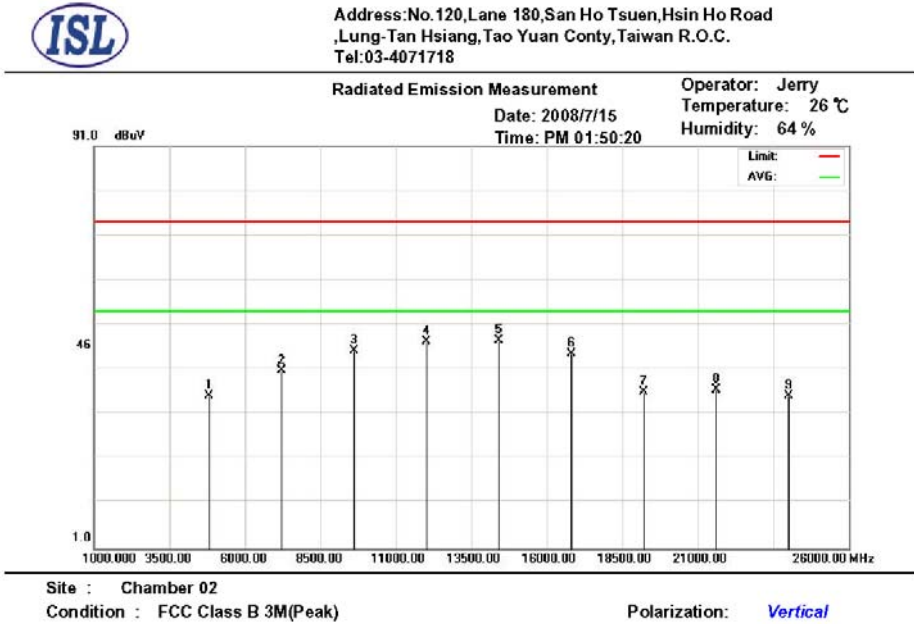

Mk.	Frequency (MHz)	RX_R (dBuV)	Ant_F (dB)	Cab_L (dB)	PreAmp (dB)	Emission (dBuV)	Limit (dBuV)	Margin (dB)	Ant.Pos (cm)	Tab.Pos (deg.)	Detector
	4804.000	29.19	33.55	2.83	30.46	35.11	74.00	-38.89	132	231	peak
	7206.000	30.10	38.04	3.37	30.89	40.62	74.00	-33.38	100	4	peak
	9608.000	29.51	40.08	3.99	28.26	45.32	74.00	-28.68	164	356	peak
	12010.000	32.79	41.71	4.47	31.8	47.17	74.00	-26.83	100	119	peak
*	14412.000	30.61	43.44	4.85	31.5	47.40	74.00	-26.60	237	62	peak
	16814.000	28.26	41.77	5.38	30.95	44.46	74.00	-29.54	211	43	peak
	19216.000	27.64	32.39	5.66	29.8	35.89	74.00	-38.11	100	52	peak
	21618.000	25.05	33.1	6.02	27.7	36.47	74.00	-37.53	158	256	peak
	24020.000	23.55	33.31	5.87	27.73	35.00	74.00	-39.00	133	280	peak

*:Maximum data x:Over limit !:over margin

Note:

- According to the standards used, Where limits are specified by agencies for both average and peak (or quasi-peak) detection, if the peak (or quasi-peak) measured value complies with the average limit, it is unnecessary to perform an average measurement.
- “ * ”: Fundamental Frequency, “**”: Not in the restricted band, Limit level=Fundamental Emission-20dB
- “ pk”: peak mode, “av”: average mode
- “---”: No meter reading data due to the emission level is smaller than spectrum noise level.
- The Spectrum noise level+Correction Factor < Limit - 6 dB
- Margin=Corrected Amplitude – Limit
- Corrected Amplitude=Radiated Amplitude+Antenna Correction Factor+Cable Loss-Pre-Amplifier Gain
- A margin of -8dB means that the emission is 8dB below the limit.

All frequencies from 1GHz to 25 GHz have been tested.

1GHz~ 25 GHz (Horizontal), Channel 39: 2441 MHz

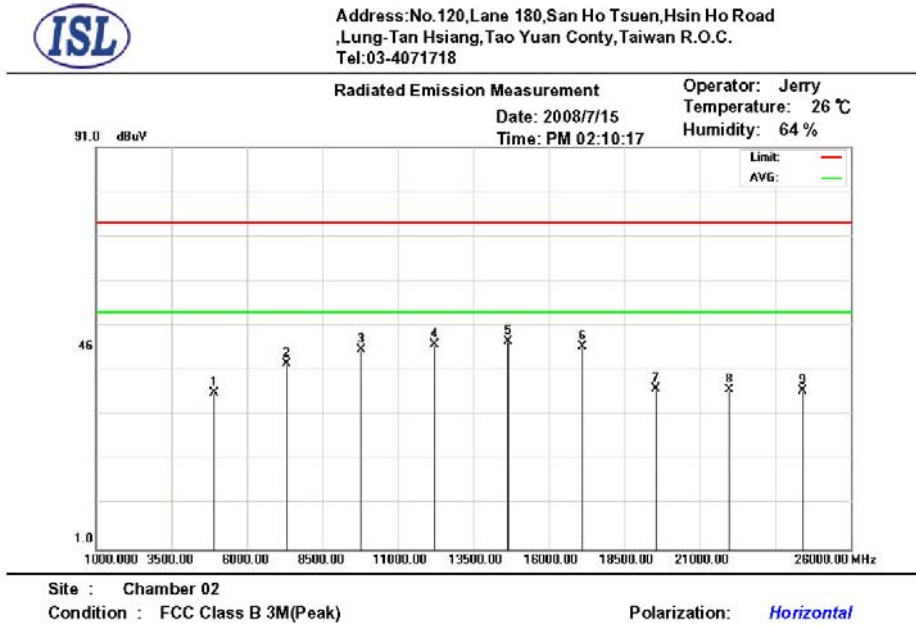

Mk.	Frequency (MHz)	RX_R (dBuV)	Ant_F (dB)	Cab_L (dB)	PreAmp (dB)	Emission (dBuV)	Limit (dBuV)	Margin (dB)	Ant.Pos (cm)	Tab.Pos (deg.)	Detector
	4882.000	29.87	33.77	2.82	30.56	35.90	74.00	-38.10	363	120	peak
	7323.000	31.53	38.34	3.38	30.78	42.47	74.00	-31.53	298	112	peak
	9764.000	30.03	40.05	4.03	28.36	45.75	74.00	-28.25	114	44	peak
	12205.000	32.40	41.82	4.53	31.88	46.87	74.00	-27.13	100	331	peak
*	14646.000	30.72	43.12	4.87	31.21	47.50	74.00	-26.50	397	134	peak
	17087.000	28.81	43.28	5.43	31.1	46.42	74.00	-27.58	100	75	peak
	19528.000	28.42	32.5	5.71	29.78	36.85	74.00	-37.15	151	196	peak
	21969.000	25.27	33.1	6.08	27.7	36.75	74.00	-37.25	100	18	peak
	24410.000	25.73	33.46	5.53	28.27	36.45	74.00	-37.55	116	197	peak

*:Maximum data x:Over limit !:over margin

1GHz~ 25 GHz (Vertical) Channel 39: 2441 MHz



Address: No. 120, Lane 180, San Ho Tsuen, Hsin Ho Road
, Lung-Tan Hsiang, Tao Yuan Conty, Taiwan R.O.C.
Tel: 03-4071718

Radiated Emission Measurement

Date: 2008/7/15
Time: PM 02:11:48

Operator: Jerry
Temperature: 26 °C
Humidity: 64 %

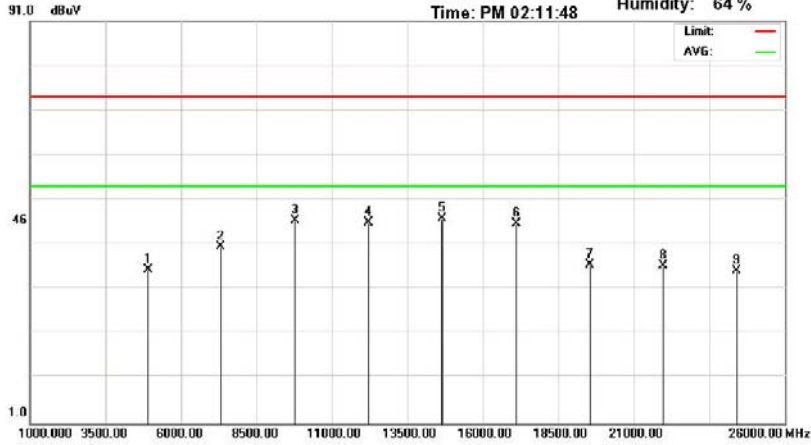

Site : Chamber 02

Condition : FCC Class B 3M(Peak)

Polarization: Vertical

Mk.	Frequency (MHz)	RX_R (dBuV)	Ant_F (dB)	Cab_L (dB)	PreAmp (dB)	Emission (dBuV)	Limit (dBuV)	Margin (dB)	Ant.Pos (cm)	Tab.Pos (deg.)	Detector
	4882.000	29.26	33.77	2.82	30.56	35.29	74.00	-38.71	285	27	peak
	7323.000	29.62	38.34	3.38	30.78	40.56	74.00	-33.44	238	75	peak
	9764.000	30.60	40.05	4.03	28.36	46.32	74.00	-27.68	185	260	peak
	12205.000	31.39	41.82	4.53	31.88	45.86	74.00	-28.14	100	201	peak
*	14646.000	30.08	43.12	4.87	31.21	46.86	74.00	-27.14	322	178	peak
	17087.000	28.01	43.28	5.43	31.1	45.62	74.00	-28.38	149	297	peak
	19528.000	27.90	32.5	5.71	29.78	36.33	74.00	-37.67	327	208	peak
	21969.000	24.77	33.1	6.08	27.7	36.25	74.00	-37.75	132	23	peak
	24410.000	24.43	33.46	5.53	28.27	35.15	74.00	-38.85	287	296	peak

*:Maximum data x:Over limit !:over margin

Note:

- According to the standards used: Where limits are specified by agencies for both average and peak (or quasi-peak) detection, if the peak (or quasi-peak) measured value complies with the average limit, it is unnecessary to perform an average measurement.
- “ * ”: Fundamental Frequency, “**”: Not in the restricted band, Limit level=Fundamental Emission-20dB
- “ pk”: peak mode, “av”: average mode
- “---”: No meter reading data due to the emission level is smaller than spectrum noise level.
- The Spectrum noise level+Correction Factor < Limit - 6 dB
- Margin=Corrected Amplitude – Limit
- Corrected Amplitude=Radiated Amplitude+Antenna Correction Factor+Cable Loss-Pre-Amplifier Gain
- A margin of -8dB means that the emission is 8dB below the limit.

All frequencies from 1GHz to 25 GHz have been tested.

1GHz~ 25 GHz (Horizontal), Channel 78: 2480 MHz



Address: No.120, Lane 180, San Ho Tsuen, Hsin Ho Road
, Lung-Tan Hsiang, Tao Yuan Conty, Taiwan R.O.C.
Tel: 03-4071718

Radiated Emission Measurement

Date: 2008/7/15
Time: PM 02:15:34

Operator: Jerry
Temperature: 26 °C
Humidity: 64 %

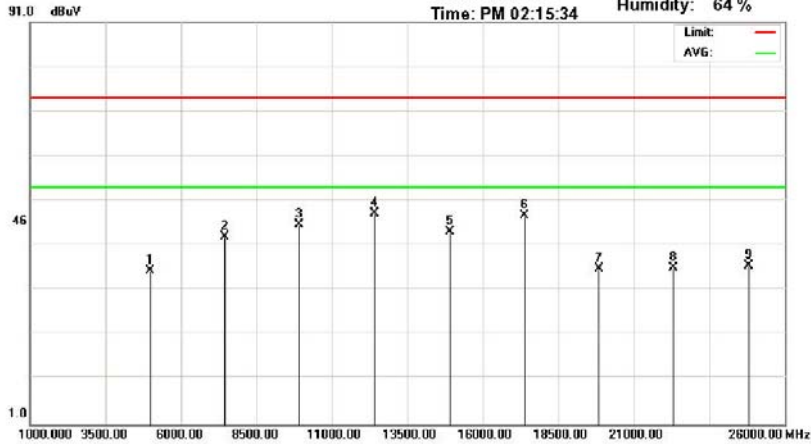

Site : Chamber 02

Condition : FCC Class B 3M(Peak)

Polarization: Horizontal

Mk.	Frequency (MHz)	RX_R (dBuV)	Ant_F (dB)	Cab_L (dB)	PreAmp (dB)	Emission (dBuV)	Limit (dBuV)	Margin (dB)	Ant.Pos (cm)	Tab.Pos (deg.)	Detector
	4960.000	29.14	33.99	2.81	30.65	35.29	74.00	-38.71	100	50	peak
	7440.000	31.55	38.64	3.39	30.66	42.92	74.00	-31.08	184	140	peak
	9920.000	30.00	40.02	4.08	28.45	45.65	74.00	-28.35	341	18	peak
*	12400.000	33.49	41.94	4.58	31.96	48.05	74.00	-25.95	100	152	peak
	14880.000	27.78	42.18	4.89	30.74	44.11	74.00	-29.89	111	8	peak
	17360.000	29.15	44.15	5.46	31.1	47.66	74.00	-26.34	226	214	peak
	19840.000	27.04	32.5	5.76	29.6	35.70	74.00	-38.30	343	88	peak
	22320.000	24.00	33.61	6.13	27.76	35.98	74.00	-38.02	220	53	peak
	24800.000	25.98	34.34	5.4	29.36	36.36	74.00	-37.64	208	150	peak

*:Maximum data x:Over limit !:over margin

1GHz~ 25 GHz (Vertical), Channel 78 : 2480 MHz

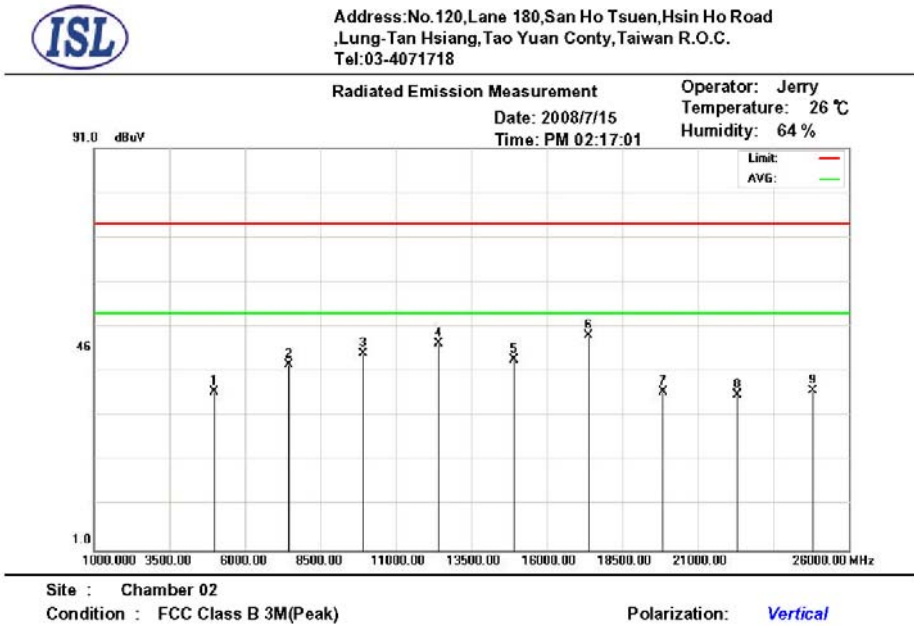

Mk.	Frequency (MHz)	RX_R (dBuV)	Ant_F (dB)	Cab_L (dB)	PreAmp (dB)	Emission (dBuV)	Limit (dBuV)	Margin (dB)	Ant.Pos (cm)	Tab.Pos (deg.)	Detector
	4960.000	30.39	33.99	2.81	30.65	36.54	74.00	-37.46	100	71	peak
	7440.000	31.21	38.64	3.39	30.66	42.58	74.00	-31.42	160	297	peak
	9920.000	29.26	40.02	4.08	28.45	44.91	74.00	-29.09	201	154	peak
	12400.000	32.73	41.94	4.58	31.96	47.29	74.00	-26.71	174	337	peak
	14880.000	27.23	42.18	4.89	30.74	43.56	74.00	-30.44	226	101	peak
*	17360.000	30.45	44.15	5.46	31.1	48.96	74.00	-25.04	100	158	peak
	19840.000	27.78	32.5	5.76	29.6	36.44	74.00	-37.56	233	284	peak
	22320.000	23.89	33.61	6.13	27.76	35.87	74.00	-38.13	236	341	peak
	24800.000	26.31	34.34	5.4	29.36	36.69	74.00	-37.31	325	247	peak

*:Maximum data x:Over limit !:over margin

Note:

- According to the standards used, Where limits are specified by agencies for both average and peak (or quasi-peak) detection, if the peak (or quasi-peak) measured value complies with the average limit, it is unnecessary to perform an average measurement.
- “ * ”: Fundamental Frequency, “*”: Not in the restricted band, Limit level=Fundamental Emission-20dB
- “ pk”: peak mode, “av”: average mode
- “---”: No meter reading data due to the emission level is smaller than spectrum noise level.
- The Spectrum noise level+Correction Factor < Limit - 6 dB
- Margin=Corrected Amplitude – Limit
- Corrected Amplitude=Radiated Amplitude+Antenna Correction Factor+Cable Loss-Pre-Amplifier Gain
- A margin of -8dB means that the emission is 8dB below the limit.

All frequencies from 1GHz to 25 GHz have been tested.

4.4 Band Edge Measurement

4.4.1 Test Procedure

Conducted

1. The transmitter output of EUT was connected to the spectrum analyzer.
Equipment mode: Spectrum analyzer
Detector function: Peak mode
SPAN: 10MHz
RBW: 100KHz
VBW: 100KHz
Center frequency: 2.4GHz, 2.4835GHz.
2. Using Peak Search to read the peak power of Carrier frequencies after Maximum Hold function is completed
3. Find the next peak frequency outside the operation frequency band

Radiated

1. Antenna and Turntable test procedure same as Radiated Emission Measurement.
Equipment mode: Spectrum analyzer
Detector function: Peak mode
SPAN: 10MHz
RBW: 100KHz
VBW: 100KHz
Center frequency: 2.4GHz, 2.4835GHz.
2. Using Peak Search to read the peak power of Carrier frequencies after Maximum Hold function is completed
3. Find the next peak frequency outside the operation frequency band

4.4.2 Test Setup

Conducted

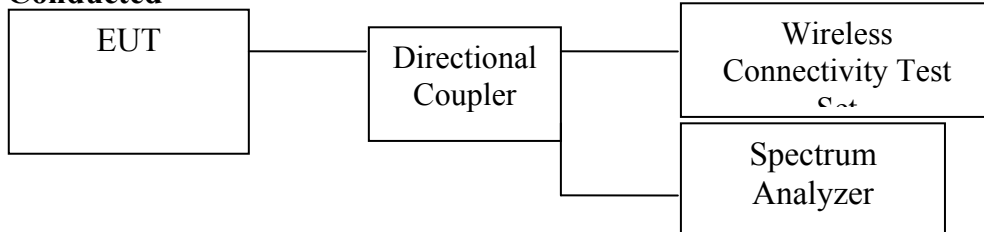

Radiated

Same as *Radiated Emission Measurement*

4.4.3 Test Data:

Table: Band Edge measurement (Conducted)

Conducted Test

Temperature (°C):27

Test Engineer:Jerry Chiou

Humidity (%):65

Channel	Frequency (MHz)	Spectrum Reading (dBuV)	Carrier - Outsideband Limit: >20dB (dB)	Pass/Fail
00	2401.96	106.86	---	---
Outside band	2399.96	59.88	46.98	Pass
78	2479.96	106.66	---	---
Outside band	2483.96	56.28	50.38	Pass

Radiated Test

Temperature (°C):27

Test Engineer:Jerry Chiou

Humidity (%):60

Channel	Frequency (MHz)	Spectrum Reading (dBuV)	Carrier - Outsideband Limit: >20dB (dB)	Pass/Fail
00	2401.94	64.68	---	---
Outside band	2399.95	22.42	42.26	Pass
78	2479.95	64.37	---	---
Outside band	2483.96	14.76	49.61	Pass

Band Edge Conducted Measurement

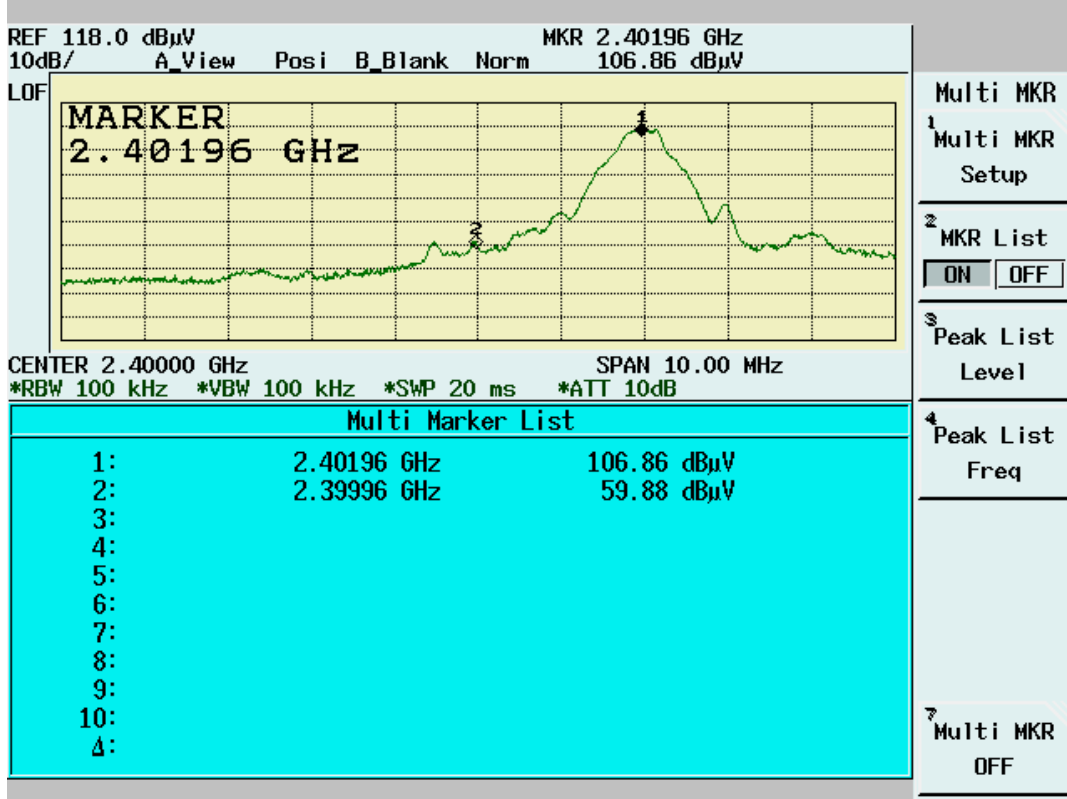

Band Edge Conducted Measurement

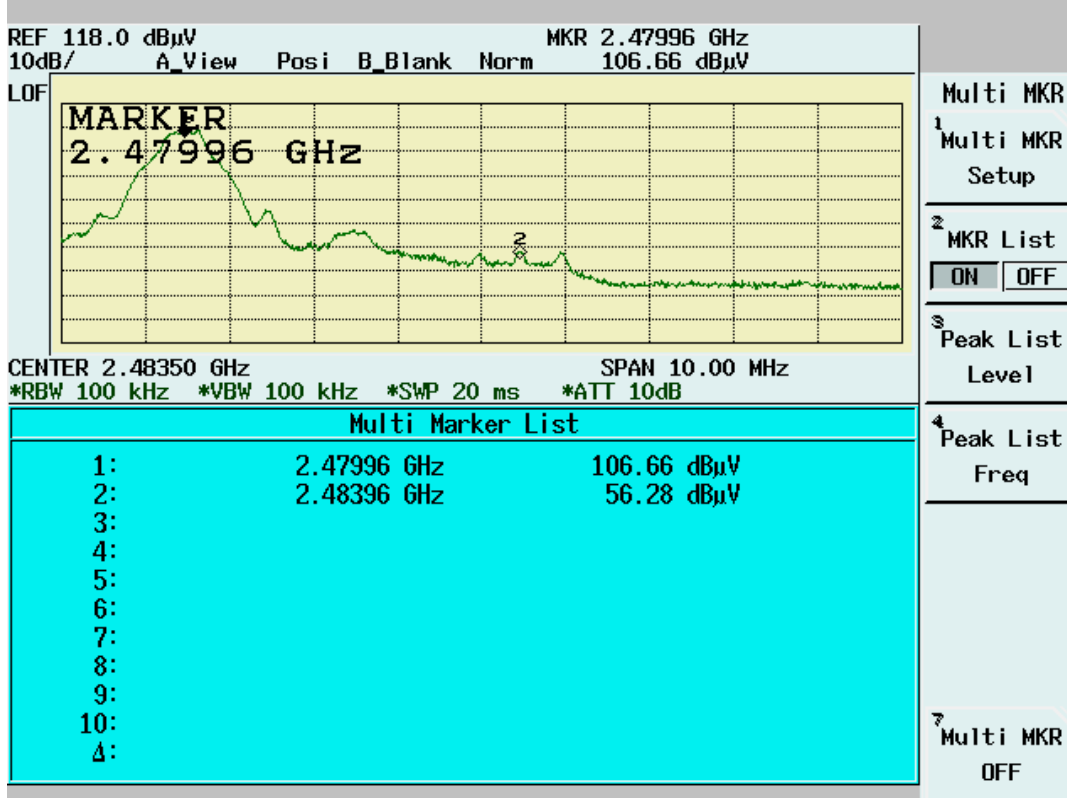

Band Edge Radiated Measurement

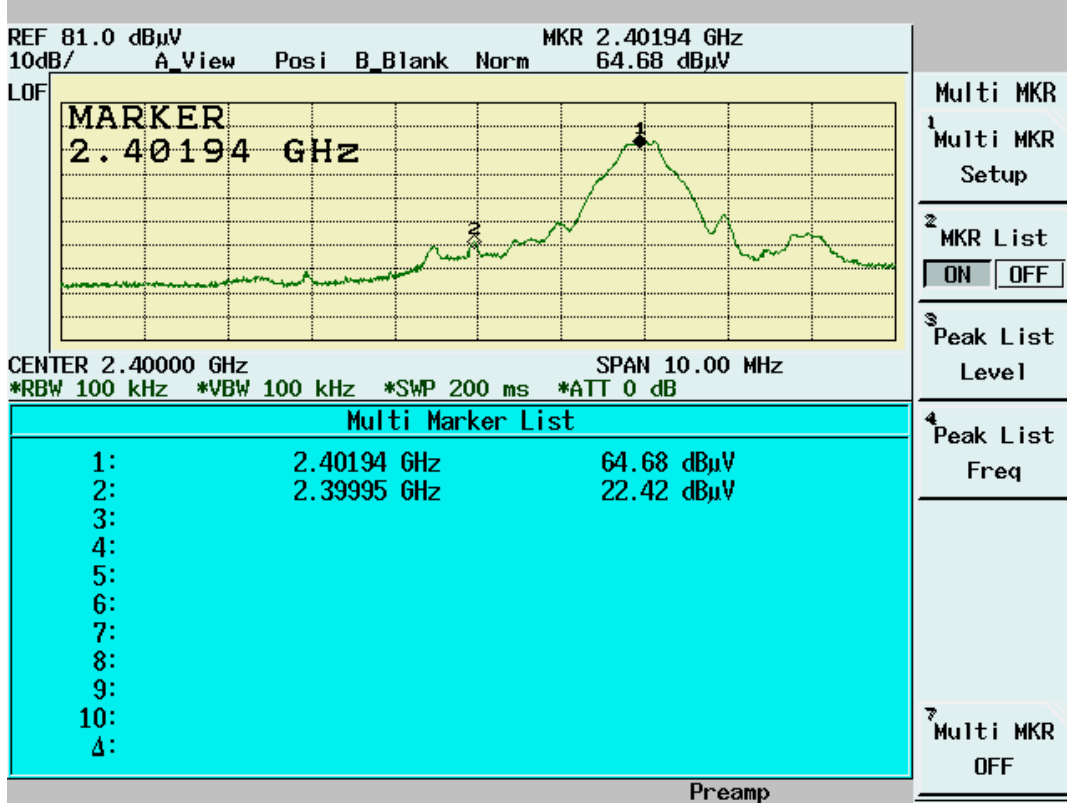

Band Edge Radiated Measurement

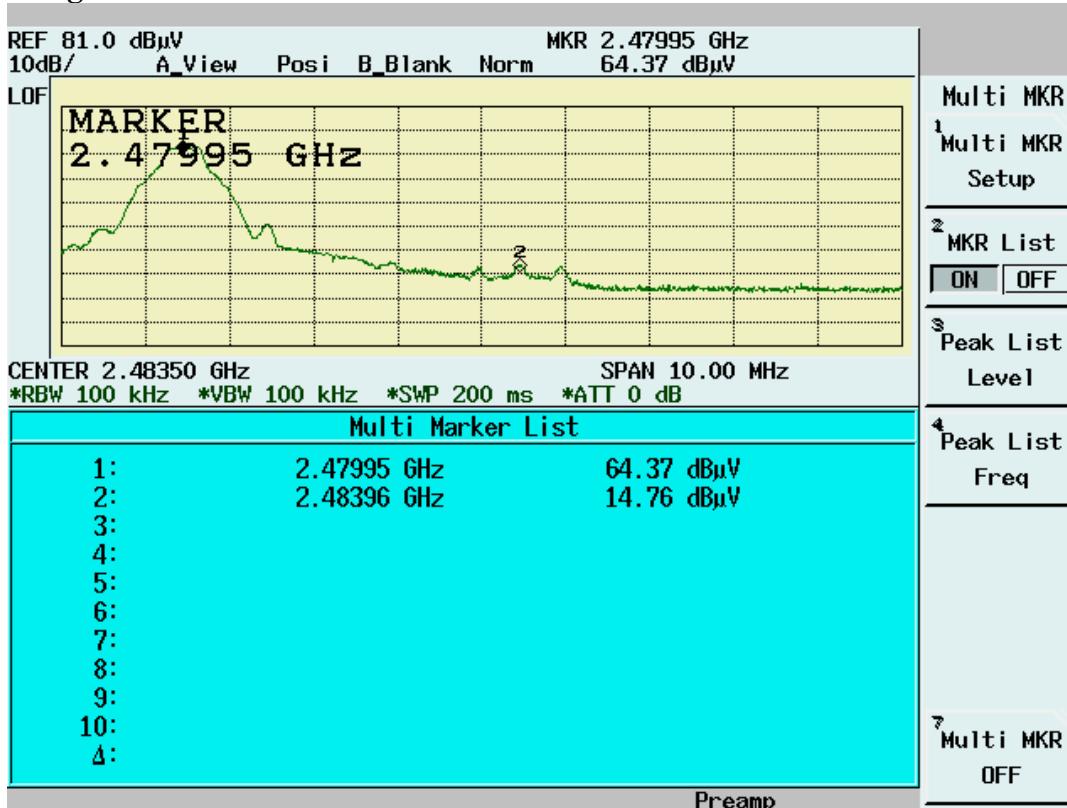

4.5 Restricted Bands Measurement

4.5.1 Test Procedure (Radiated)

1. Antenna and Turntable test procedure same as Radiated Emission Measurement.
Equipment mode: Spectrum analyzer
Detector function: Peak mode
SPAN: 30MHz
RBW: 1MHz
VBW: 3MHz
Center frequency: 2.39GHz, 2.4835GHz.
2. Using Peak Search to read the peak power of Carrier frequencies after Maximum Hold function is completed.
3. Find the next peak frequency outside the operation frequency band
4. For peak frequency emission level measurement in Restricted Band,
Change RBW: 1MHz
VBW: 1KHz
Span: 30MHz.
5. Get the spectrum reading after Maximum Hold function is completed.

4.5.2 Test Setup (Radiated)

Same as *Radiated Emission Measurement*

4.5.3 Test Data

Table Band Edge measurement (Radiated)

Temperature (°C):27

Test Engineer:Jerry Chiou

Humidity (%):60

Description	Frequency (MHz)	Spectrum Reading (dBuV)	Correction Factor (dB/m)	Emission Level (dBuV/m)	Limit (dBuV/m)	Equip. Setup VBW	Pass or Fail
Channel_00 (peak mode)	2401.97	64.9	30.7	95.6	---	3MHz	---
Channel_00 (average mode)	2401.97	64.23	30.7	94.93	---	10Hz	---
Channel_78 (peak mode)	2479.96	64.61	30.78	95.39	---	3MHz	---
Channel_78 (average mode)	2479.95	63.94	30.78	94.72	---	10Hz	---
Channel_00 Restricted band (peak mode)	2385.89	17.88	30.69	48.57	74	3MHz	Pass
Restricted band (average mode)	2385.89	9.02	30.69	39.71	54	10Hz	Pass
Channel_78 Restricted band (peak mode)	2483.79	21.98	30.78	52.76	74	3MHz	Pass
Restricted band (average mode)	2483.79	11.17	30.78	41.95	54	10Hz	Pass

Note:

- The Spectrum plot of emission level measurement in Restricted band is attached.
- Emission Level=Spectrum Reading+Correction Factor
- Correction Factor=Antenna Factor+cable loss–amplifier gain
- Both Horizontal and Vertical polarizaion have been tested and the worst data is listed above.

Restricted Band (Radiated)-Peak Mode (Channel 00)

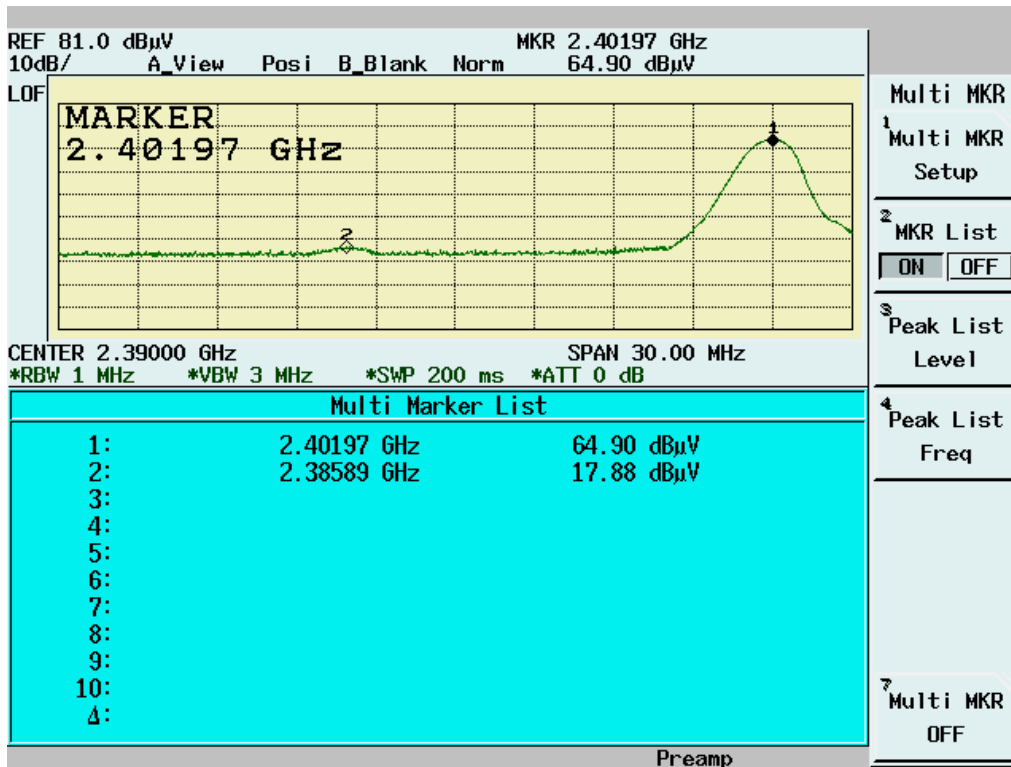

Restricted Band (Radiated)-Average Mode (Channel 00)

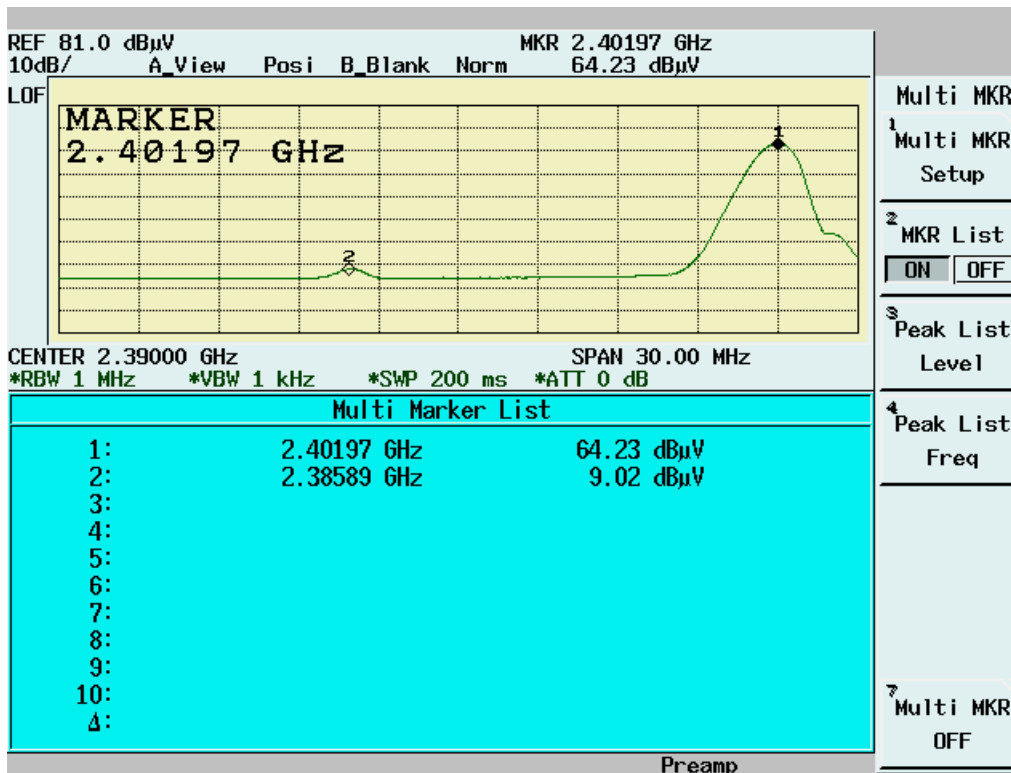

Restricted Band (Radiated)-Peak Mode (Channel 78)

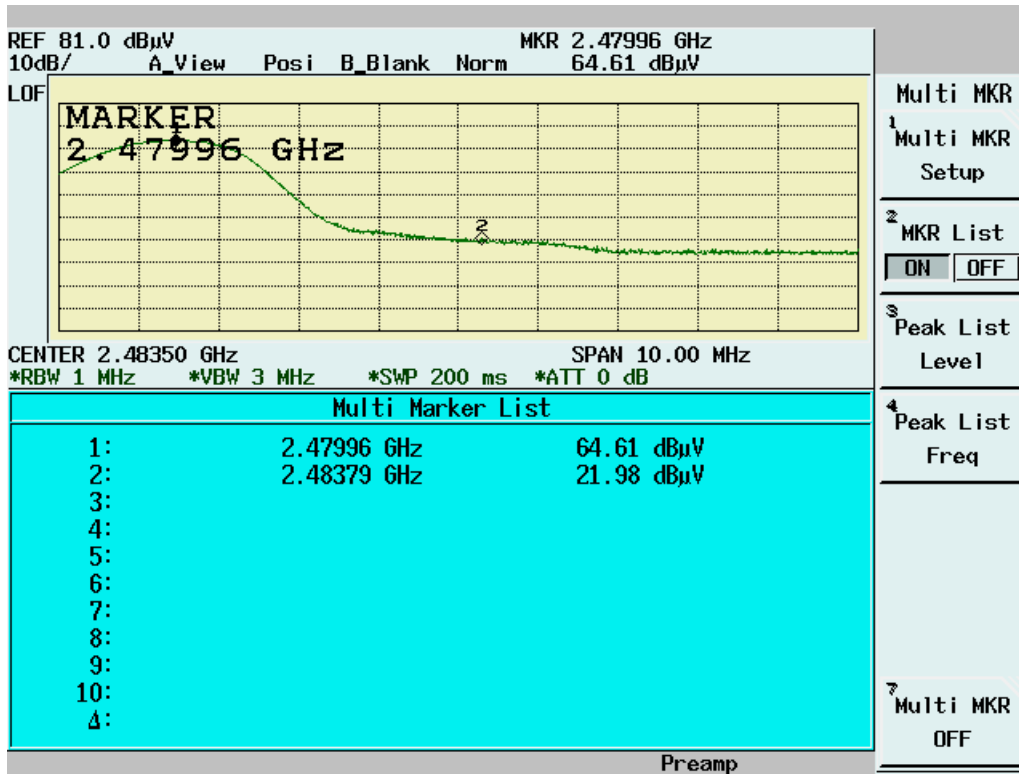

Restricted Band (Radiated)-Average Mode (Channel 78)

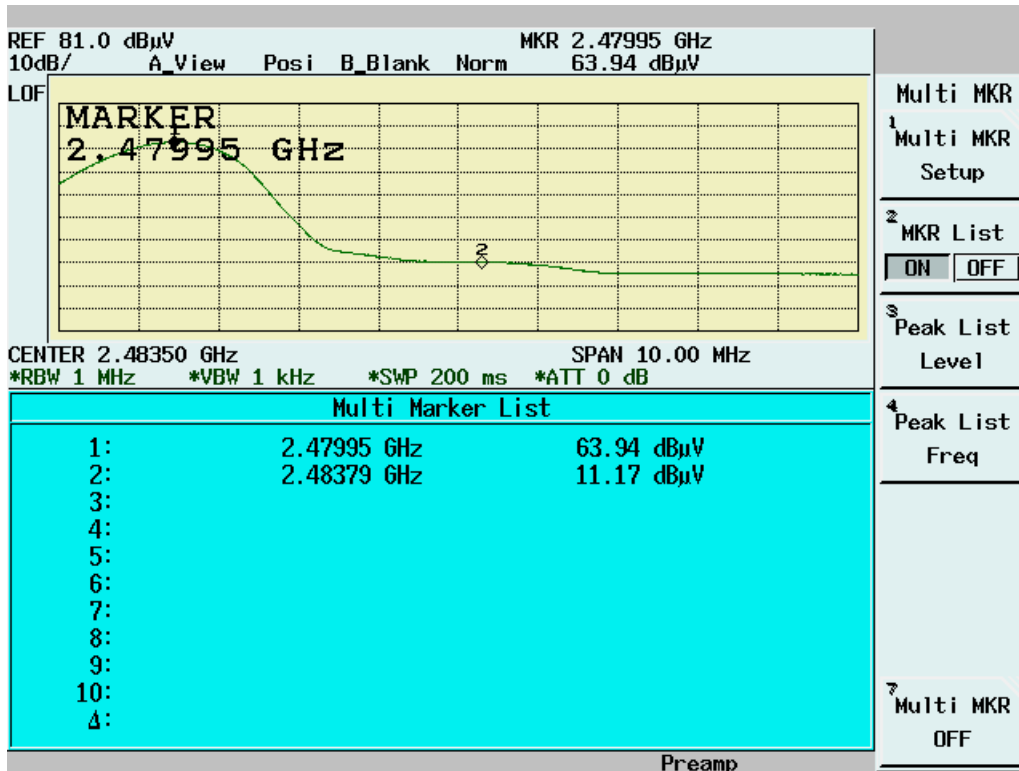

4.6 Bandwidth & Hopping Channel Separation

4.6.1 Standard Applicable

According to §15.247(a)(1), frequency hopping system shall have, hopping channel carrier frequencies separated by a minimum of 25 kHz or the 20 dB bandwidth of the hopping channel, whichever is greater. The system shall hop to channel frequencies that are selected at the system hopping rate from a pseudorandomly ordered list of hopping frequencies.

4.6.2 Test Procedure

■ Bandwidth Test Procedure

The Transmitter output of EUT was connected to the spectrum analyzer. The 20 dB bandwidth of the fundamental frequency was measured. The setting of spectrum analyzer is as follows

Equipment mode	Spectrum analyzer
Detector function	Peak mode
RBW	30KHz
VBW	100KHz

■ Hopping Channel Separation Test Procedure

1. Connect EUT antenna terminal to the spectrum analyzer with a low loss cable.
Equipment mode: Spectrum analyzer
RBW: 100KHz
VBW: 300KHz
SPAN:3MHz
2. By using the Max-Hold function record the separation of two adjacent channels.
3. Measure the frequency difference of these two adjacent channels by spectrum analyzer Marker function.
4. Repeat above procedures until all frequencies measured were complete.

4.6.3 Test Setup

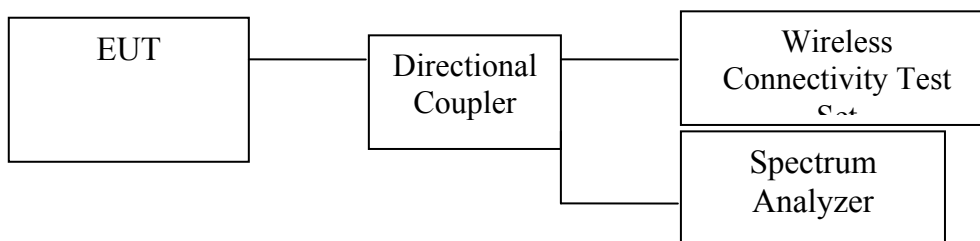

4.6.4 Test Data

20dB Bandwidth

Temperature (°C):27

Test Engineer:Jerry Chiou

Humidity (%):65

Channel	Frequency (MHz)	20dB Bandwidth (KHz)	Limit (KHz)	Pass/Fail
00	2402	1044	≤ 1000	Pass
39	2441	1044	≤ 1000	Pass
78	2480	1052	≤ 1000	Pass

Hopping Channel Separation

Temperature (°C):27

Test Engineer:Jerry Chiou

Humidity (%):65

Channel	Frequency (MHz)	Separation (KHz)	Limit (KHz)	Pass/Fail
00	2402	1000	≥ 1044	Pass
39	2441	1000	≥ 1044	Pass
78	2480	1000	≥ 1052	Pass

20dB Bandwidth Channel 00:

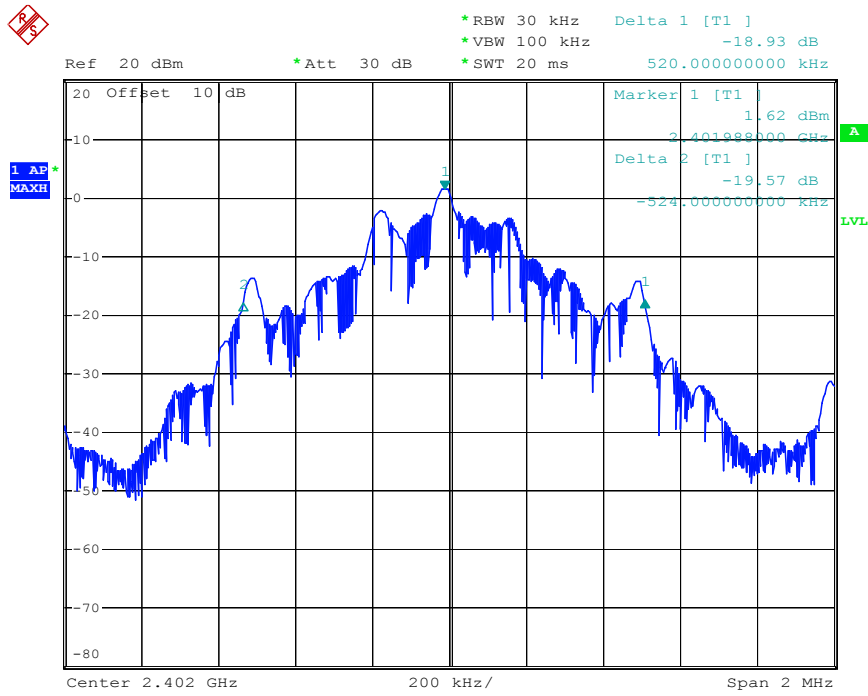

Date: 11.MAR.2009 16:33:37

20dB Bandwidth Channel 39:

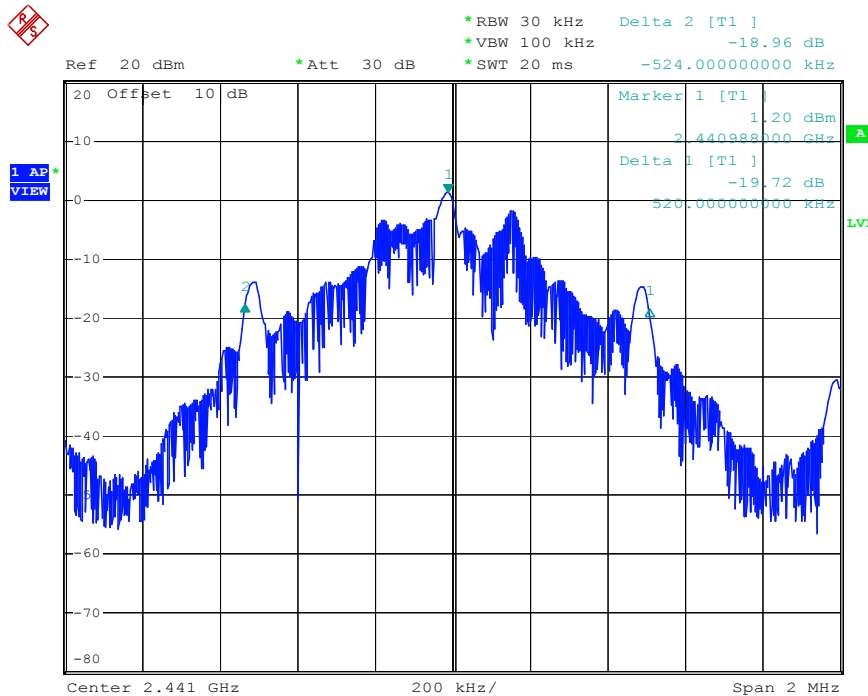

Date: 11.MAR.2009 16:36:49

20dB Bandwidth Channel 78:

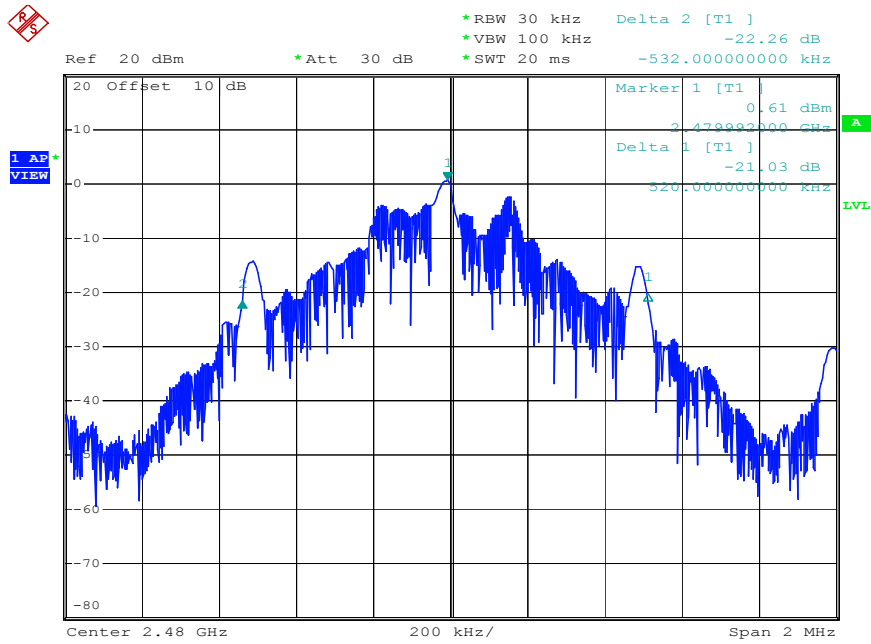

Date: 11.MAR.2009 16:38:35

Hopping Channel Separation Channel 00

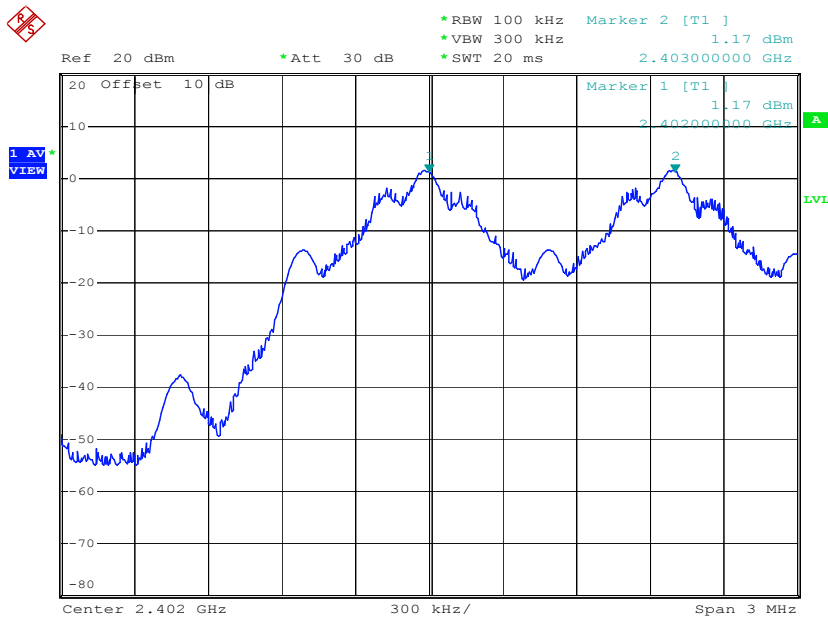

Date: 11.MAR.2009 17:02:54

Hopping Channel Separation Channel 39

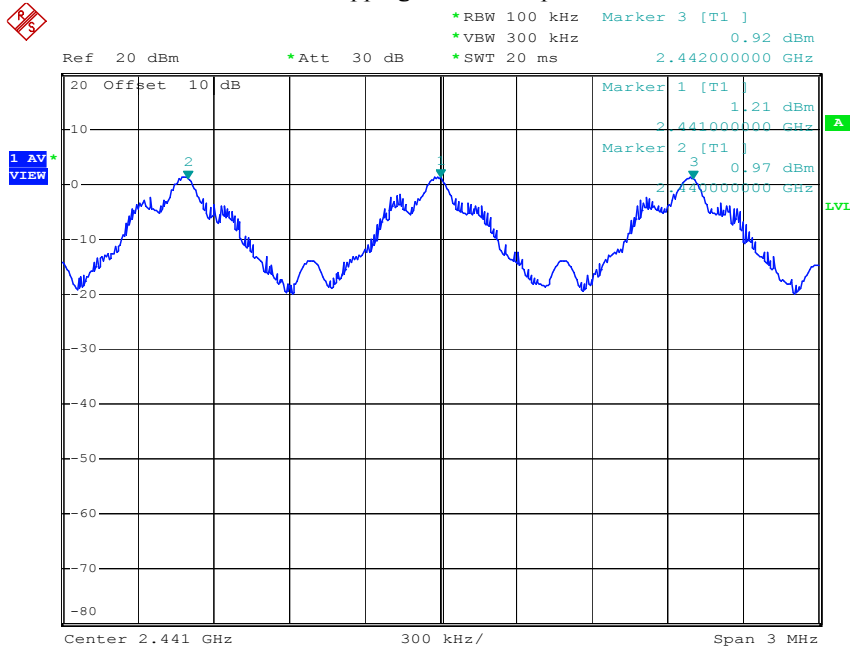

Date: 11.MAR.2009 17:04:13

Hopping Channel Separation Channel 78

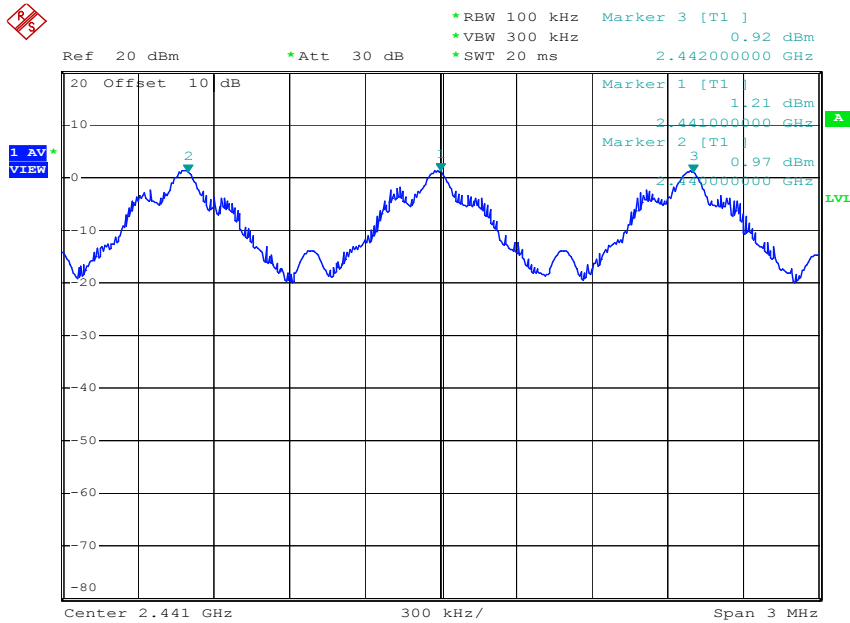

Date: 11.MAR.2009 17:04:13

4.7 Number of Hopping Frequency Used

4.7.1 Test Procedure

1. Connect EUT antenna terminal to the spectrum analyzer with a low loss cable.
Equipment mode: Spectrum analyzer
RBW: 300KHz
VBW: 1MHz
2. Set the spectrum analyzer on Max-Hold Mode, and then keep the EUT in hopping mode. Record all the signals from each channel until each one has been recorded.
3. Repeat above procedures until all frequencies measured were complete.

4.7.2 Test Setup

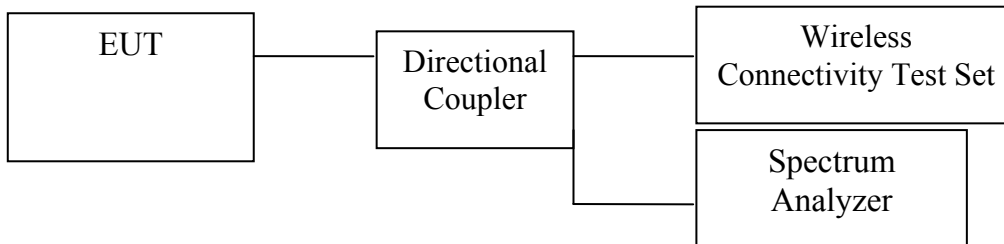

4.7.3 Test Data

Number of Hopping Frequency Used

Temperature (°C):27

Humidity (%):65

Test Engineer:Jerry Chiou

Test result	Limit (Channels)	Pass/Fail
79	>75	Pass

2400~2405MHz

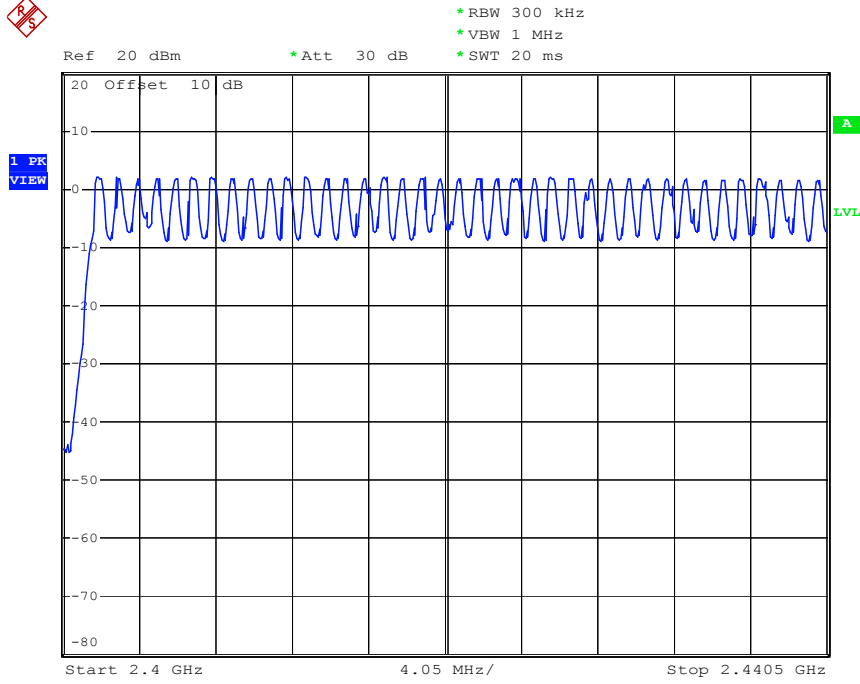

Date: 10.MAR.2008 17:28:43

2405~2482MHz

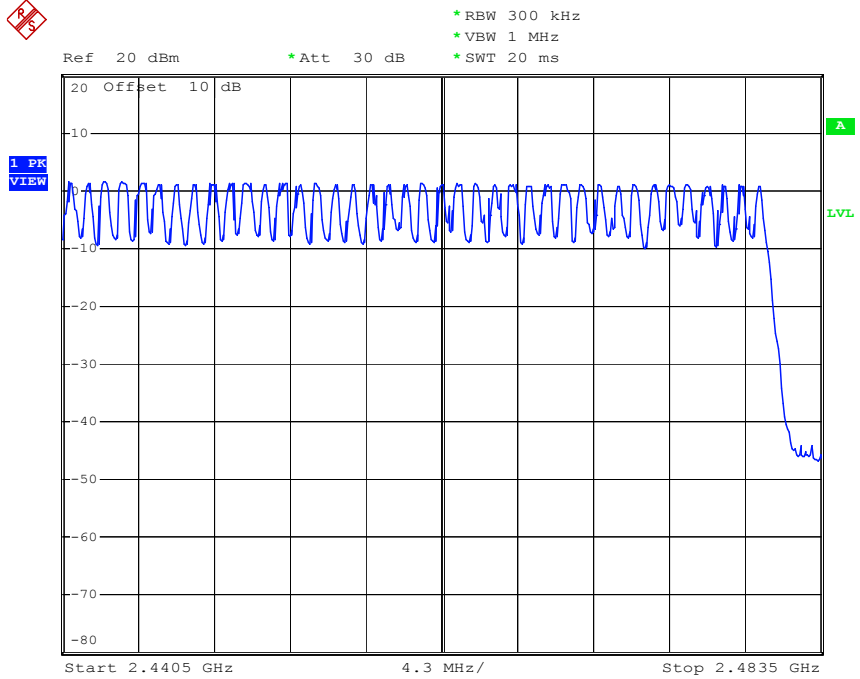

Date: 10.MAR.2008 17:30:52

4.8 Dwell Time

4.8.1 Test Procedure

1. Connect EUT antenna terminal to the spectrum analyzer with a low loss cable.
Equipment mode: Spectrum analyzer
RBW: 1MHz
VBW: 1MHz
SPAN: Zero Span
2. Adjust the center frequency of spectrum analyzer on any frequency be measured.
3. Measure the Dwell Time by spectrum analyzer Marker function.
4. Repeat above procedures until all frequencies measured were complete.

4.8.2 Test Setup

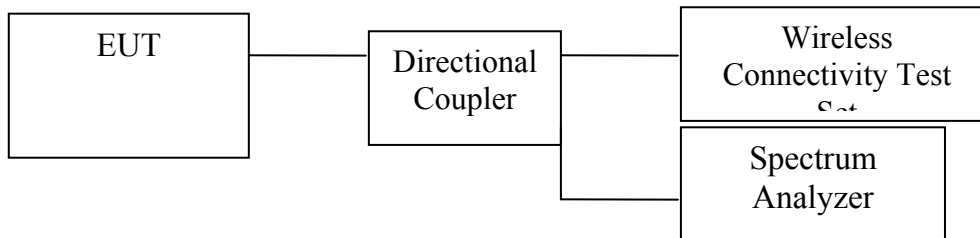

4.8.3 Test Data

Dwell Time

Temperature (°C):27

Humidity (%):65

Test Engineer:Jerry Chiou

Mode	Frequency (MHz)	Spectrum Reading (µs)	Test Result (ms)	Limit (ms)	Pass/Fail
DH1	2402	416	266.24	< 400	Pass
DH3	2402	1680	358.40	< 400	Pass
DH5	2402	2920	373.76	< 400	Pass

Mode	Frequency (MHz)	Spectrum Reading (µs)	Test Result (ms)	Limit (ms)	Pass/Fail
DH1	2441	422	270.08	< 400	Pass
DH3	2441	1682	358.83	< 400	Pass
DH5	2441	2930	375.04	< 400	Pass

Mode	Frequency (MHz)	Spectrum Reading (µs)	Test Result (ms)	Limit (ms)	Pass/Fail
DH1	2480	420	268.80	< 400	Pass
DH3	2480	1680	358.40	< 400	Pass
DH5	2480	2930	375.04	< 400	Pass

Note:

A period time=79x0.4(s)=31.6(s)

CH00	DH1 time slot=	$416 (\mu s) * (1600 / (1 * 79)) * 31.6 =$	266.24 (ms)
	DH3 time slot=	$1680 (\mu s) * (1600 / (3 * 79)) * 31.6 =$	358.40 (ms)
	DH5 time slot=	$2920 (\mu s) * (1600 / (5 * 79)) * 31.6 =$	373.76 (ms)
CH39	DH1 time slot=	$422 (\mu s) * (1600 / (1 * 79)) * 31.6 =$	270.08 (ms)
	DH3 time slot=	$1682 (\mu s) * (1600 / (3 * 79)) * 31.6 =$	358.83 (ms)
	DH5 time slot=	$2930 (\mu s) * (1600 / (5 * 79)) * 31.6 =$	375.04 (ms)
CH78	DH1 time slot=	$420 (\mu s) * (1600 / (1 * 79)) * 31.6 =$	268.80 (ms)
	DH3 time slot=	$1680 (\mu s) * (1600 / (3 * 79)) * 31.6 =$	358.40 (ms)
	DH5 time slot=	$2930 (\mu s) * (1600 / (5 * 79)) * 31.6 =$	375.04 (ms)

Channel 00 DH1:

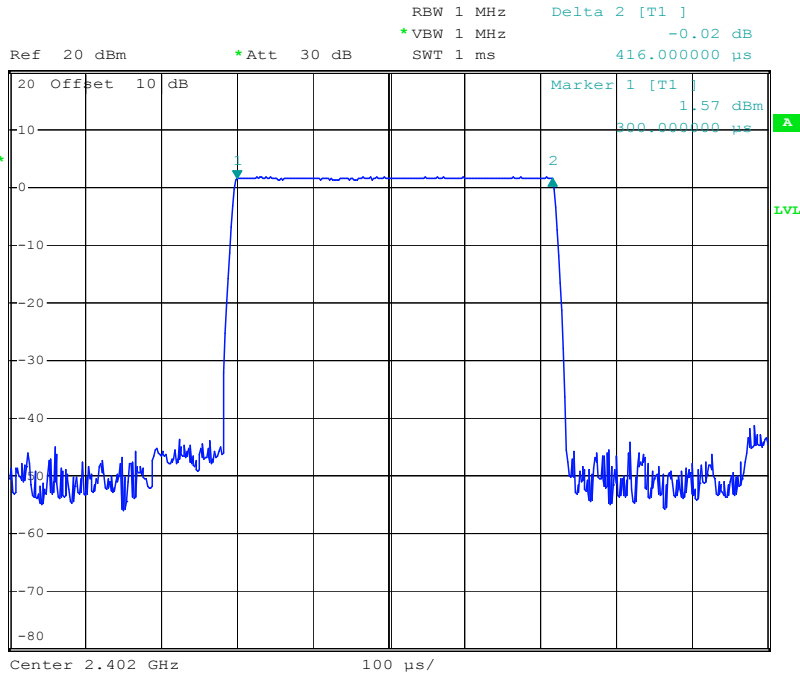

Date: 11.MAR.2009 17:09:58

Channel 00 DH3:

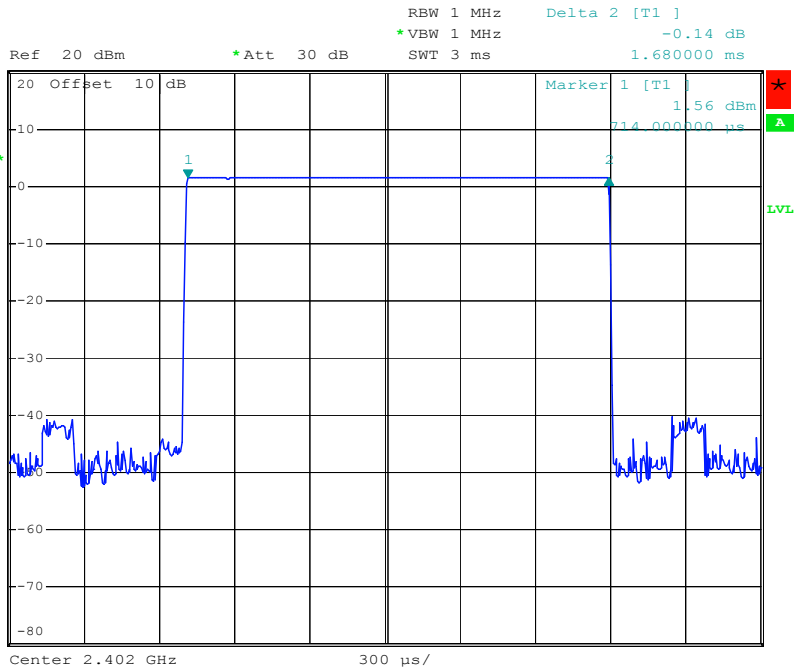

Date: 10.MAR.2008 17:15:04

Channel 00 DH5:

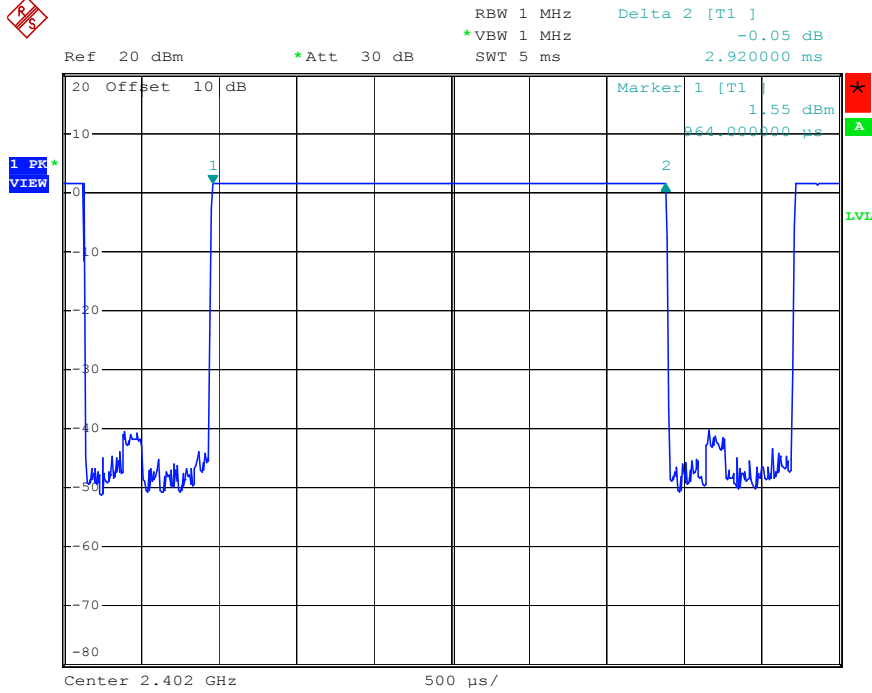

Date: 10.MAR.2008 17:17:42

Channel 39 DH1:

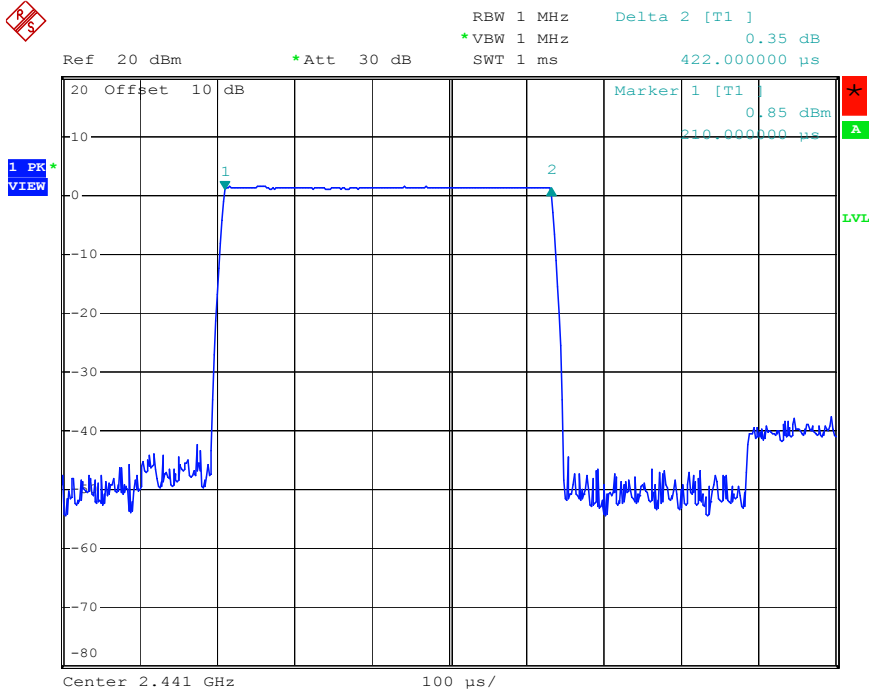

Date: 10.MAR.2008 17:20:51

Channel 39 DH3:

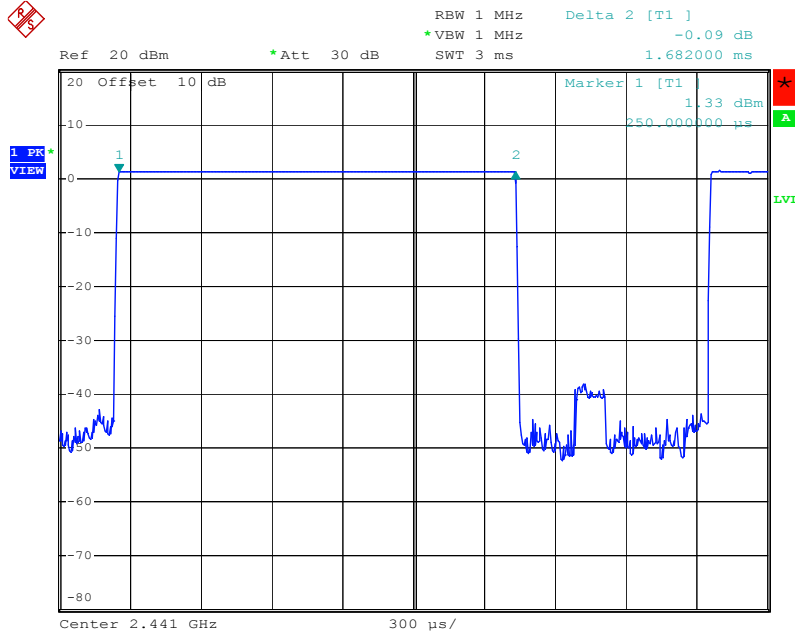

Date: 10.MAR.2008 17:19:56

Channel 39 DH5:

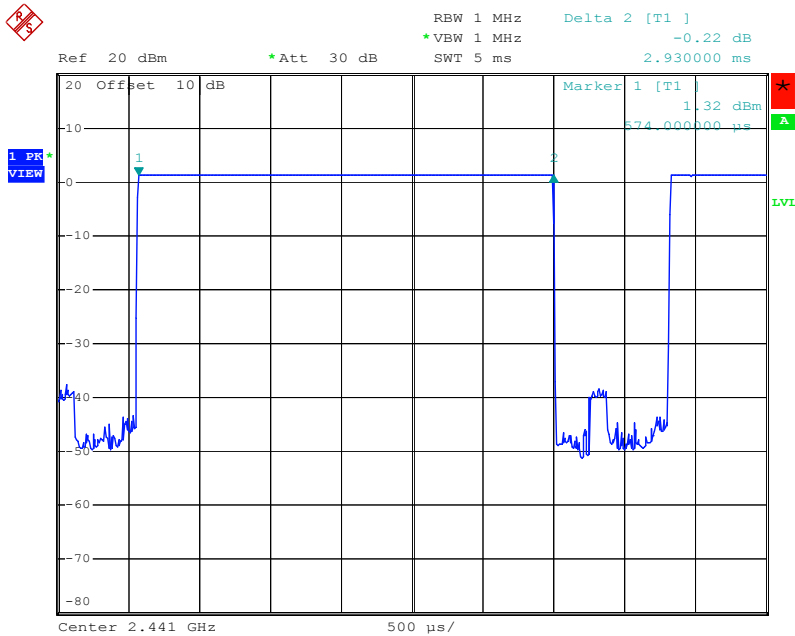

Date: 10.MAR.2008 17:18:43

Channel 78 DH1:

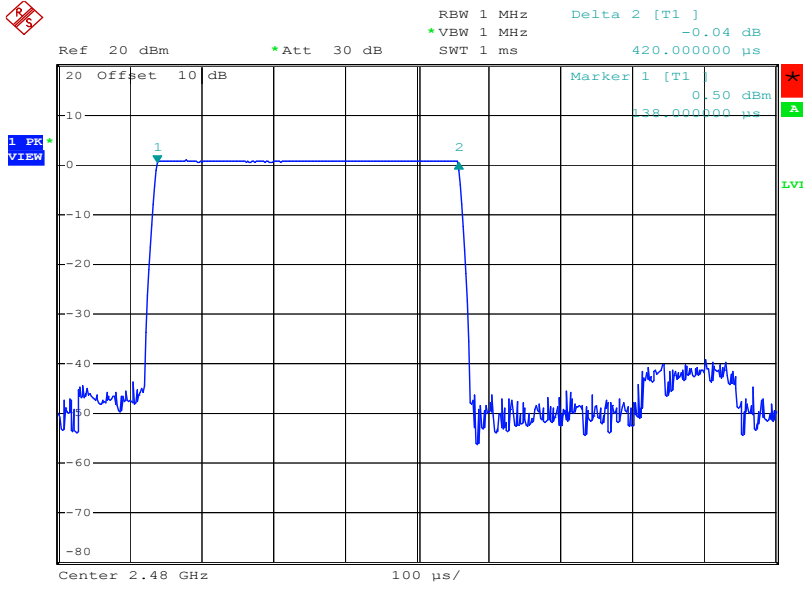

Date: 10.MAR.2008 17:23:57

Channel 78 DH3:

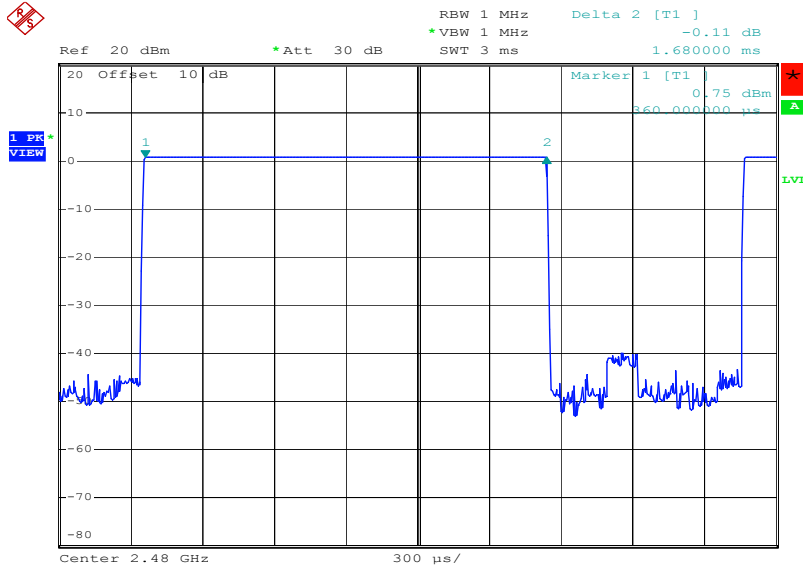

Date: 10.MAR.2008 17:24:46

Channel 78 DH5:

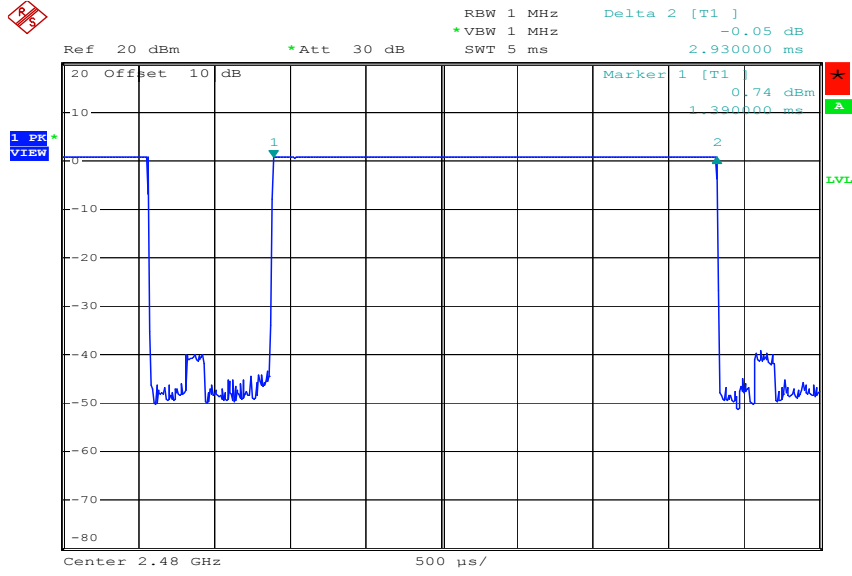

Date: 10.MAR.2008 17:25:53

5. Appendix

5.1 Appendix A: Measurement Procedure for Power line Conducted Emissions

The measurements are performed in a 3.5m x 3.4m x 2.5m shielded room, which referred as Conduction 01 test site, or a 3m x 3m x 2.3m test site, which referred as Conduction 02 test site. The EUT was placed on non-conduction 1.0m x 1.5m table, which is 0.8 meters above an earth-grounded.

Power to the EUT was provided through the LISN which has the Impedance (50ohm/50uH) vs. Frequency Characteristic in accordance with the required standard. Power to the LISNs were filtered to eliminate ambient signal interference and these filters were bonded to the ground plane. Peripheral equipment required to provide a functional system (support equipment) for EUT testing was powered from the second LISN through a ganged, metal power outlet box which is bonded to the ground plane at the LISN.

If the EUT is supplied with a flexible power cord, the power cord length in excess of the distance separating the EUT from the LISN shall be folded back and forth at the center of the lead so as to form a bundle not exceeding 40cm in length. If the EUT is provided with a permanently coiled power cord, bundling of the cord is not required. If the EUT is supplied without a power cord, the EUT shall be connected to the LISN by a power cord of the type specified by the manufacturer which shall not be longer than 1 meter. The excess power cord shall be bundled as described above. If a non-flexible power cord is provided with the EUT, it shall be cut to the length necessary to attach the EUT to the LISN and shall not be bundled.

The interconnecting cables were arranged and moved to get the maximum emission. Both the line of power cord, hot and neutral, were measured.

The highest emissions were analyzed in details by operating the spectrum analyzer in fixed tuned mode to determine the nature of the emissions and to provide information which could be useful in reducing their amplitude.

5.2 Appendix B: Test Procedure for Radiated Emissions

Preliminary Measurements in the Anechoic Chamber

The radiated emissions are initially measured in the anechoic chamber at a measurement distance of 3 meters. Desktop EUT are placed on a wooden stand 0.8 meter in height. The measurement antenna is 3 meters from the EUT. The test setup in anechoic chamber is the same as open site. The turntable rotated 360°. The antenna height is varied from 1-2.5m. The primary objective of the radiated measurements in the anechoic chamber is to identify the frequency spectrum in the absence of the electromagnetic environment existing on the open test site. The frequencies can then be pre-selected on the open test site to obtain the corresponding amplitude. The initial scan is made with the spectrum analyzer in automatic sweep mode. The spectrum peaks are then measured manually to determine the exact frequencies.

Measurements on the Open Site or 10m EMC Chamber

The radiated emissions test will then be repeated on the open site or 10m EMC chamber to measure the amplitudes accurately and without the multiple reflections existing in the shielded room. The EUT and support equipment are set up on the turntable of one of the 3 or 10 meter open field sites. Desktop EUT are set up on a wooden stand 0.8 meter above the ground.

For the initial measurements, the receiving antenna is varied from 1-4 meter height and is changed in the vertical plane from vertical to horizontal polarization at each frequency. Both readings are recorded with the quasi-peak detector with 120KHz bandwidth. For frequency between 30 MHz and 1000MHz, the reading is recorded with peak detector or quasi-peak detector. For frequency above 1 GHz, the reading is recorded with peak detector or average detector with 1 MHz bandwidth.

At the highest amplitudes observed, the EUT is rotated in the horizontal plane while changing the antenna polarization in the vertical plane to maximize the reading. The interconnecting cables were arranged and moved to get the maximum emission. Once the maximum reading is obtained, the antenna elevation and polarization will be varied between specified limits to maximize the readings.

5.3 Appendix C: Test Equipment

5.3.1 Test Equipment List

Location	Equipment Name	Brand	Model	S/N	Last Cal. Date	Next Cal. Date
Radiation	BILOG Antenna 08	Schaffner	CBL6112B	2756	06/13/2008	06/12/2009
Radiation	Coaxial Cable Chmb 02-10M	Belden	RG-8/U	Chmb 02-10M	02/13/2008	02/12/2009
Radiation	Digital Hygro-Thermometer Chmb 02	MicroLife	HT-2126G	Chmb 02	12/26/2006	12/26/2008
Radiation	EMI Receiver 02	HP	85460A	3448A00183	12/29/2007	12/28/2008
Radiation	Spectrum Analyzer 13	Advantest	R3132	121200411	03/16/2008	03/15/2009
Radiation	Horn Antenna 02	Com-Power	AH-118	10088	12/28/2007	12/27/2008
Radiation	Horn Antenna 04	Com-Power	AH-826	081-001	03/23/2008	03/22/2009
Radiation	Microwave Cable RF SK-01	HUBER+SUHNERAG.	Sucoflex 102	22139 /2	06/01/2008	06/01/2009
Radiation	Preamplifier 09	MITEQ	AFS44-001026 50-40-10P-44	858687	04/02/2008	04/02/2009
Radiation	High Pass Filter 01	HEWLETT-PACKARD	84300-80038	001	N/A	N/A
Radiation	Spectrum Analyzer 19	R&S	FSP40	100116	09/12/2007	09/12/2008
Chamber 05	Wireless Connectivity Test Set 01	Agilent	N4010A	MY48100200	05/23/2008	05/23/2009
Chamber 05	Directional Coupler	Agilent	87300C	MY44300272	N/A	N/A
Radiation	Spectrum Analyzer 14	Advantest	R3182	140600028	12/06/2007	12/06/2008

Note: Calibration is traceable to NIST or national or international standards.

5.3.2 Software for Controlling Spectrum/Receiver and Calculating Test Data

Radiation/Conduction	Filename	Version	Issued Date
Conduction	Tile.exe	1.12E	7/7/2000
Radiation	Tile.exe	1.12C	6/16/2000

5.4 Appendix D: Layout of EUT and Support Equipment

5.4.1 General Conducted Test Configuration

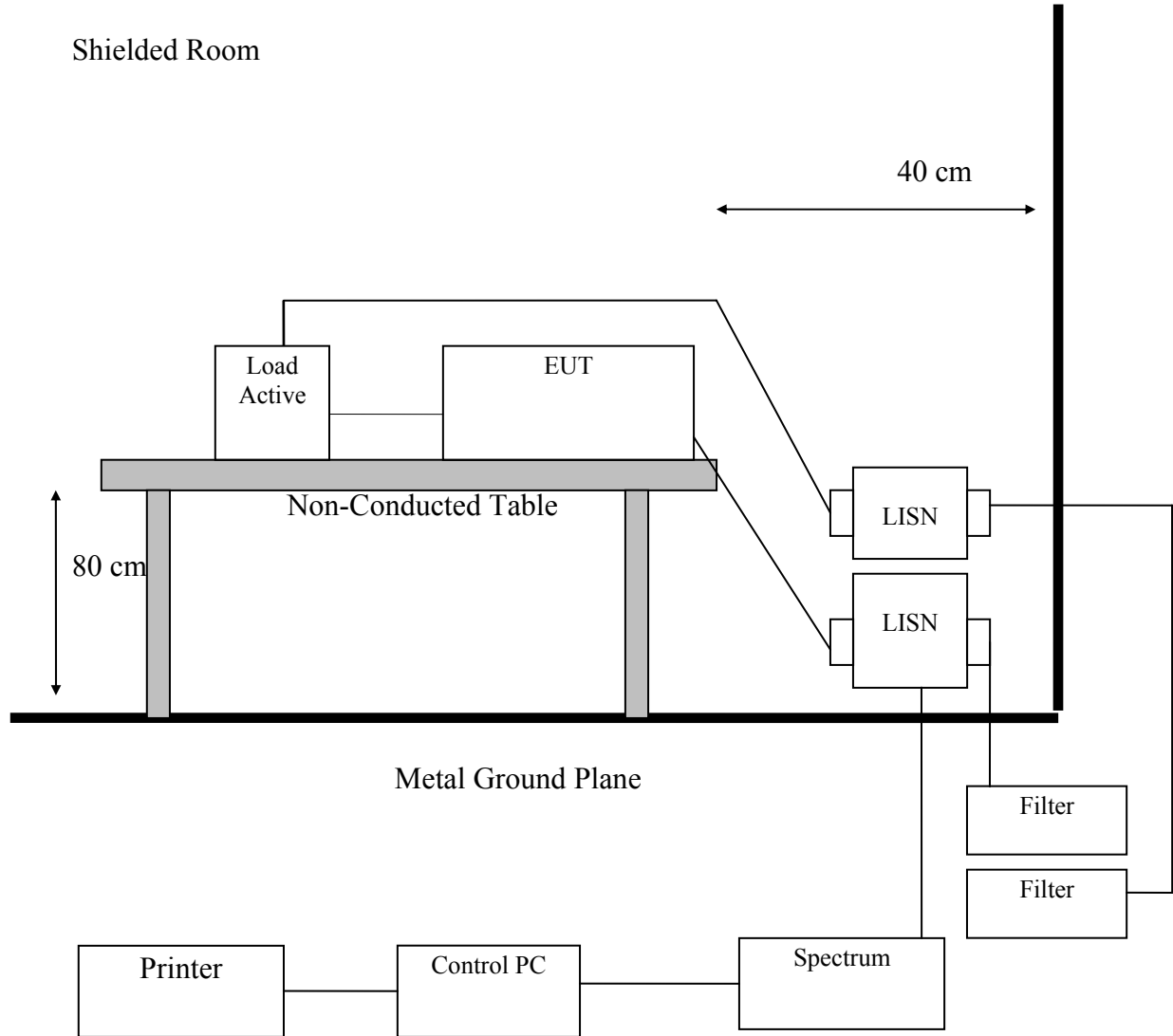

5.4.2 General Radiation Test Configuration

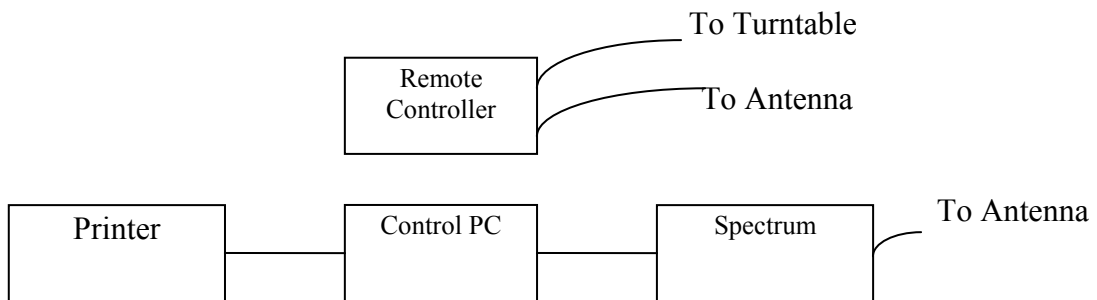
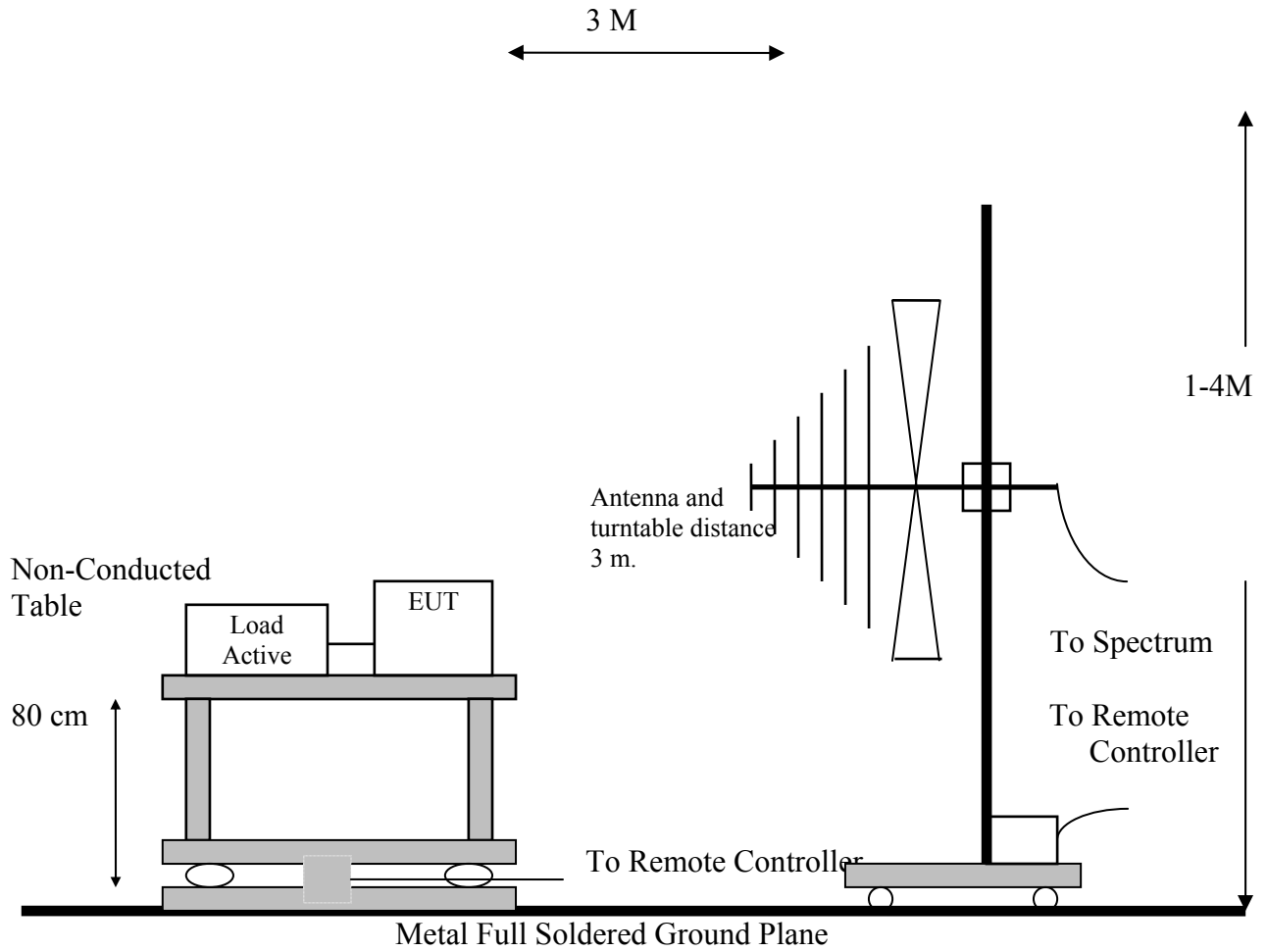

5.5 Appendix E: Accuracy of Measurement

The measurement uncertainty refers to CISPR 16-4-2:2003. The coverage factor $k = 2$ yields approximately a 95 % level of confidence.

<Chamber 02 (3M)>

1GHz~18GHz: $\pm 2.62\text{dB}$

18GHz~26GHz: $\pm 2.94\text{dB}$

26GHz~40GHz: $\pm 2.70\text{dB}$

5.6 Appendix F: Photographs of EUT Configuration Test Set Up

The Front View of Highest Radiated Set-up For EUT

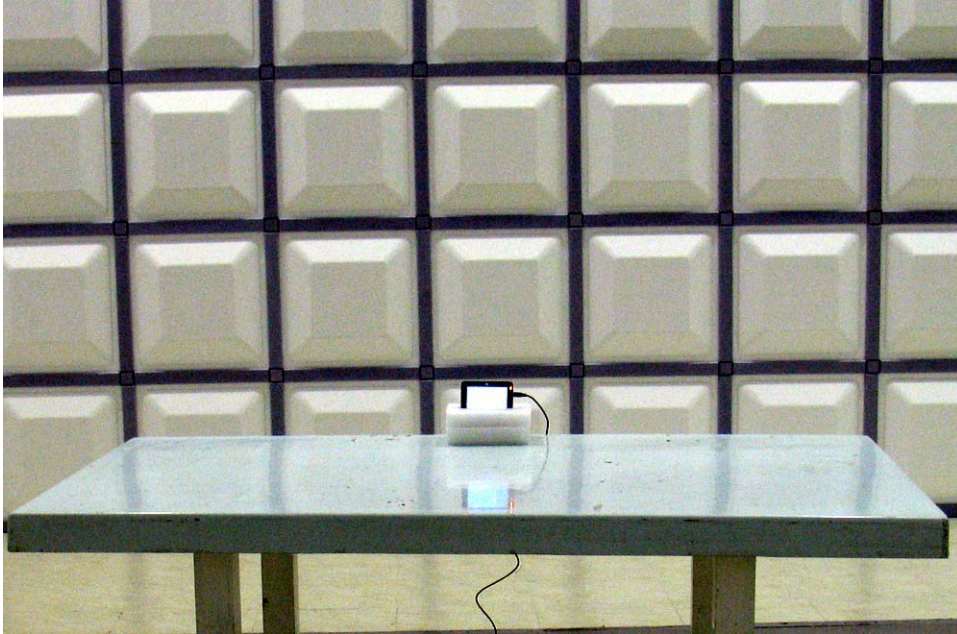

The Back View of Highest Radiated Set-up For EUT

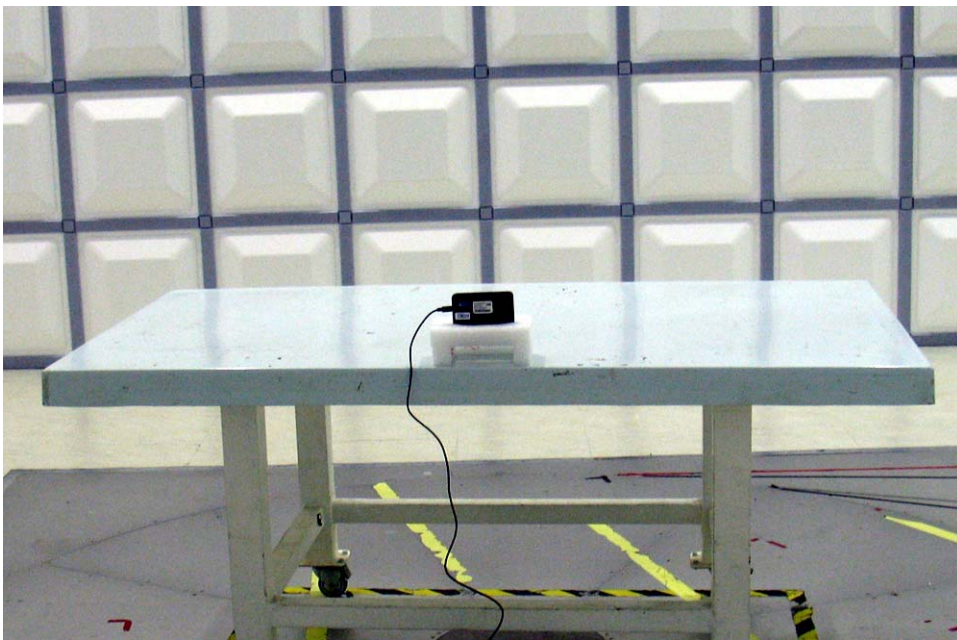

5.7 Appendix G: Antenna Spec.

Please refer to the attached file.