

MOTOROLA W24 DEVELOPER'S GUIDE  
MODULE HARDWARE DESCRIPTION

**6802984C95-X11**

## Table of Contents

Table of Contents .....	2
Preface.....	5
Manual Scope.....	5
Target Audience.....	5
Manual Organization .....	5
Applicable Documents.....	5
Regulatory Requirements.....	6
Regulatory Statement (Safety).....	6
Precautions.....	7
Antenna and Transmission Safety Precautions.....	8
User Operation.....	8
Antenna Installation .....	8
Standards.....	9
Contact Us.....	9
Text Conventions .....	10
Note.....	10
Warning.....	10
Important.....	10
Caution.....	10
Field Service .....	10
General Safety.....	10
Remember! . . . Safety depends on you! .....	10
Do not operate in an explosive atmosphere .....	10
Do not service or adjust alone.....	11
Keep away from live circuits .....	11
Do not substitute parts or modify equipment.....	11
Dangerous Procedure Warnings .....	11
Caring for Environment .....	12
Disposal of Motorola equipment in EU countries .....	12
Disposal of Motorola equipment in non-EU countries .....	12
Limitation of Liability.....	13
Warranty Notification .....	13
How to Get Warranty Service? .....	14
Claiming.....	14
Conditions.....	14
What is Not Covered by the Warranty.....	15
Installed Data .....	15
Out of Warranty Repairs .....	15
Revision History .....	16
Manual Number .....	16
Manual Title.....	16
Version Information.....	16
Chapter 1: Introduction .....	17
Operation setup .....	17

Stand Alone operating setup .....	17
Stack Assembly operating setup .....	17
Product Specifications .....	19
Regulatory Approvals .....	20
Chapter 2: Hardware Interface Description .....	22
Architecture Overview .....	22
Digital Block .....	22
Power Management Block .....	23
RF Block .....	23
Operating Modes .....	24
Power Supply .....	25
Power Supply Design .....	25
Power Consumption .....	26
Power On/Off Operation .....	27
Turning the W24 On .....	27
Power Supply Turn-on .....	<b>Error! Bookmark not defined.</b>
Turning the W24 On Using ON_N .....	27
Turning the W24 On Using IGN .....	28
Turning the W24 Off .....	28
Turning the W24 Off Using ON_N .....	29
Turning the W24 Off Using IGN .....	29
Power Loss shutdown .....	29
Turning the W24 Off Using AT+iMRST .....	30
Low Power Mode .....	31
Activating Low Power Mode .....	31
Serial Interface During Low Power Mode .....	32
Terminating Low Power Mode .....	33
Temporary Termination of Low Power Mode .....	33
Using the WKUPI_N signal .....	33
Using the WKUPO_N signal .....	34
Incoming Network Data .....	35
Serial Interfaces .....	37
Primary UART (UART1) .....	37
Secondary UART (UART2) .....	38
USB Device Interface .....	39
USB Host Interface (Stack configuration only) .....	39
SIM Interface .....	40
Audio Interface .....	41
A/D Converter Interface .....	42
Unused/Reserved Signals .....	43
Controls and Indicators Interface .....	44
Reset .....	44
VREF Reference Regulator .....	44
Wakeup .....	45
Antenna Detection .....	45
GPRS/EGPRS Detection .....	45

Transmission Indicator.....	45
Wi-Fi LED Indicator.....	45
Mode Select .....	45
General Purpose I/O.....	46
Antenna Interface.....	47
Chapter 3: Electrical and Environmental Specifications .....	48
Absolute Maximum Ratings .....	48
Environmental Specifications .....	49
Application Interface Specifications.....	50
Chapter 4: Mechanical Specifications .....	56
Board Dimensions.....	56
Interface Connector Specifications .....	58
RF Connector Specifications .....	59
Mating Connector .....	59
INSERT DRAWING FROM G24 Manual.....	60
W24 Stand Alone Mounting .....	60
W24 + G24 stack mounting .....	61
Chapter 5: Service and Testing .....	62
Service.....	<b>Error! Bookmark not defined.</b>
Who to Contact? .....	62
Required Query Information.....	62
Service Centers .....	64
Testing a Standalone Unit.....	65
Test Setup.....	<b>Error! Bookmark not defined.</b>

# Preface

## ***Manual Scope***

This manual provides the electrical, mechanical and environmental requirements for properly integrating the W24 module in a host application.

This manual gives a complete set of hardware features and functions that may be provided by W24. The availability of any feature or function, which is described in this manual, depends on the hardware revision and software version of a specific W24 model.

The parameters and values provided in this manual are defined under typical conditions. These values may vary when subject to different conditions, such as SW version, network status, application settings and environmental conditions.

## ***Target Audience***

This manual is intended for all members of the integration team who are responsible for integrating the W24 into the host application, including representatives from hardware, software and RF engineering disciplines.

## ***Manual Organization***

This manual contains the following chapters:

- **Chapter 1**— introduces the W24 unit and provides important safety instructions.
- **Chapter 2**—provides a detailed hardware description of the blocks and components comprising the W24.
- **Chapter 3**—describes the pin assignments for W24 connectors.
- **Chapter 4**—describes W24 mechanical specifications and requirements.
- **Chapter 5**—provides contact information for Motorola Service Support and Customer Assistance.

## ***Applicable Documents***

- Motorola W24 Developer's Guide - Developer's Kit: 6802985C05
- Motorola W24 Developer's Guide - AT+i Commands: 6802985C10
- Motorola G24 Developer's Guide – Module Hardware Description: 6889192V27-G
- Motorola G24 Developer's Guide – AT Commands Reference Manual: 6889192V28

## Regulatory Requirements

The Federal Communications Commission (FCC) requires application for certification of digital devices in accordance with CFR Title 47, Part 15 Sub Part C ,section 15.247 and Part 15 Sub Part B sections 15.107,15.109 This includes MPE calculation. As the W24 modem is not a standalone transceiver but is an integrated module, the W24 cannot be tested by itself for EME certification. It is, however, the integrator's responsibility to have the completed device tested for EME certification.

### Caution:

Unauthorized repairs or modifications could result in permanent damage to the equipment and void your warranty and your authority to operate this device under Part 15 of the FCC Rules.

## Regulatory Statement (Safety)

The following safety precautions must be observed during all phases of the operation, usage, service or repair of any cellular terminal or mobile incorporating the W24 module. Manufacturers of the cellular terminal are advised to convey the following safety information to users and operating personnel, and to incorporate these guidelines into all manuals supplied with the product. Failure to comply with these precautions violates safety standards of design, manufacture and intended use of the product. Motorola assumes no liability for customer failure to comply with these precautions..

- The W24 must be operated at the voltages described in the technical documentation
- The W24 must not be mechanically or electrically changed. Use of connectors should follow the guidance of the technical documentation
- The W24 is designed to meet the Spectrum requirements of ETS 300328
- The W24 has been partially tested to EN301489-17 since compliance to ESD requirements will depend critically on the integration into the host device
- When integrating the W24 into a system, Motorola recommends testing the system to EN301489-17
- The W24 meets the safety requirements of EN60950
- Systems using the W24 are subject to mandatory EMC testing under directive 89/336/EEC (.(see link below)). Other directives, such as the LVD directive 73/23/EE, may also apply to a system using the W24 module.

<http://ec.europa.eu/enterprise/newapproach/standardization/harmstds/reflist.html>

## Host Label Requirement

A readily visible label is required on the outside of the host that state i.e. "FCC ID IHDP6JF1is contained within", provided the host is within the limits of the module grant. You must not remove the label from embedded module.

## FCC Notice To Users

Motorola has not approved any changes or modifications to this device by the user. Any changes or modifications could void the user's authority to operate the equipment. See 47 CFR Sec. 15.21. This device complies with part 15 of the FCC Rules. Operation is subject to the following two conditions: (1) This device may not cause harmful interference, and (2) this device must accept any interference received, including interference that may cause undesired operation. See 47 CFR Sec. 15.19(3).

If your mobile device or accessory has a USB connector, or is otherwise considered a computer peripheral device whereby it can be connected to a computer for purposes of transferring data, then it is considered a Class B device and the following statement applies:

This equipment has been tested and found to comply with the limits for a Class B digital device, pursuant to part 15 of the FCC Rules. These limits are designed to provide reasonable protection against harmful interference in a residential installation. This equipment generates, uses and can radiate radio frequency energy and, if not installed and used in accordance with the instructions, may cause harmful interference to

radio communications. However, there is no guarantee that interference will not occur in a particular installation. If this equipment does cause harmful interference to radio or television reception, which can be determined by turning the equipment off and on, the user is encouraged to try to correct the interference by one or more of the following measures:

- \_ Reorient or relocate the receiving antenna.
- \_ Increase the separation between the equipment and the receiver.
- \_ Connect the equipment to an outlet on a circuit different from that to which the receiver is connected.
- \_ Consult the dealer or an experienced radio/TV technician for help.

This device complies with Part 15 of the FCC Rules. Operation is subject to the following two conditions:

- (1) This device may not cause harmful interference.
- (2) This device must accept any interference received, including interference that may cause undesired operation.

## **Precautions**

Interface connector and some of the module circuits are not shielded. Be sure to take appropriate precautionary measures in order to avoid ESD while handling the module. ESD can damage the W24/G24 modules. Integrators need to design ESD protection on all external interfaces.



## Antenna and Transmission Safety Precautions

### User Operation

Do not operate your unit when a person is within eight inches (20 centimeters) of the antenna. A person or object within 8 inches (20 centimeters) of the antenna could impair call quality and may cause the unit to operate at a higher power level than necessary, as well as expose that person to RF energy in excess of that established by the FCC RF Exposure Guidelines.

**Important:** The unit must be installed in a manner that provides a minimum separation distance of 8 inches (20 centimeters) or more between the antenna and persons and must not be co-located or operate in conjunction with any other antenna or transmitter in order to satisfy FCC RF exposure requirements for mobile transmitting devices.

**Important:** To comply with the FCC RF exposure limits and to satisfy the categorical exclusion requirements for mobile transmitters, the requirements described in the following section, “[Antenna Installation](#)”, must be met.

### Antenna Installation

- A minimum separation distance of 8 inches (20 centimeters) must be maintained between the antenna and all persons.
- Antenna installation should be done by **professional installer** and meeting all FCC requirement as required in FCC part 15
- W24 authorized with specific antenna as specified in the FCC exhibits and in Antenna Interface section
- When using G24 module: The combined cable loss and antenna gain must not exceed +7.5 dBi (850MHz band). The combined cable loss and antenna gain must not exceed +2.5 dBi and total system output must not exceed 2.0W EIRP in the PCS (1900) band in order to comply with the EIRP limit of 24.232 (b). OEM installers must be provided with antenna installation instruction and transmitter operating conditions for satisfying RF exposure compliance.
- The FCC approval (Grant) is for W24 stand alone configuration only. Please note that this module may not be co-located or operate in conjunction with other transmitters. Any co-location condition would require a separate approval
- When using W24 module for meeting FCC The combined cable loss and antenna gain must not exceed 2.35 dBi (2400 MHz Band) and the total system output must not exceed 0.534W peak output power 15.247(b) Or/and for meeting the EN 300 328 standard Maximum EIRP spectral density 10dBm/MHz The combined cable loss and antenna gain must not exceed 3dBi
- If using W24 module with Antenna Gain more than 2.35 dBi and/or with another type or pattern from the one that used for FCC authorization it can require additional testing and/or authorization As specified in PART 15 UNLICENSED MODULAR TRANSMITTER APPROVAL

#### Section 15.203 Antenna requirement

An intentional radiator shall be designed to ensure that no antenna other than that furnished by the responsible party shall be used with the device. The use of a permanently attached antenna or of an antenna that uses a unique coupling to the intentional radiator shall be considered sufficient to comply with the provisions of this Section. The manufacturer may design the unit so that a broken antenna can be replaced by the user, but the use of a standard antenna jack or electrical connector is prohibited. This requirement does not apply to carrier current devices or to devices operated under the provisions of Sections 15.211, 15.213, 15.217, 15.219, or



15.221. Further, this requirement does not apply to intentional radiators that must be professionally installed, such as perimeter protection systems and some field disturbance sensors, or to other intentional radiators which, in accordance with Section 15.31(d), must be measured at the installation site. However, the installer shall be responsible for ensuring that the proper antenna is employed so that the limits in this Part are not exceeded.

## **Standards**

- FCC\_47cfr15.247
- [FCC 47cfr15.209 & 15cfr15.205](#) (radiated spurious emission restricted band )
- EN\_300 328
- IEEE Std 802.11b
- IEEE Std 802.11g
- EN 60950 Safety
- RSS-210 Issue 7 (IC Canada)
- EN 301 489-1
- EN 301 489-17

## **Contact Us**

We at Motorola want to make this guide as helpful as possible. Keep us informed of your comments and suggestions for improvements.

For general contact, technical support, report documentation errors and to order manuals, use this email address:

M2M.CustomerCare@motorola.com

Motorola appreciates feedback from the users of our information.



## **Text Conventions**

The following special paragraphs are used in this guide to point out information that must be read. This information may be set-off from the surrounding text, but is always preceded by a bold title in capital letters:

### **Note**

**Note:** Presents additional, helpful, non-critical information that you can use.

### **Warning**

**Warning:** Presents information to warn you of a potentially hazardous situation in which there is a possibility of personal injury.

### **Important**

**Important:** Presents information to help you avoid an undesirable situation or provides additional information to help you understand a topic or concept.

### **Caution**

**Caution:** Presents information to identify a situation in which damage to software, stored data, or equipment could occur, thus avoiding the damage.

## **Field Service**

For Field Service requests, use this email address:  
M2M.CustomerCare@motorola.com

## **General Safety**

### **Remember! . . Safety depends on you!**

The following general safety precautions must be observed during all phases of operation, service, and repair of the equipment described in this manual. Failure to comply with these precautions or with specific warnings elsewhere in this manual violates safety standards of design, manufacture, and intended use of the equipment. Motorola, Inc. assumes no liability for the customer's failure to comply with these requirements. The safety precautions listed below represent warnings of certain dangers of which we are aware. You, as the user of this product, should follow these warnings and all other safety precautions necessary for the safe operation of the equipment in your operating environment.

### **Do not operate in an explosive atmosphere**

Do not operate the equipment in the presence of flammable gases or fumes. Operation of any electrical equipment in such an environment constitutes a definite safety hazard.



## **Do not service or adjust alone**

Do not attempt internal service or adjustment unless another person, capable of rendering first aid is present.

## **Keep away from live circuits**

Operating personnel must:

- not remove equipment covers. Only Factory Authorized Service Personnel or other qualified maintenance personnel may remove equipment covers for internal subassembly, or component replacement, or any internal adjustment
- not replace components with power cable connected. Under certain conditions, dangerous voltages may exist even with the power cable removed
- always disconnect power and discharge circuits before touching them

## **Do not substitute parts or modify equipment**

Because of the danger of introducing additional hazards, do not install substitute parts or perform any unauthorized modification of equipment. Contact Motorola Warranty and Repair for service and repair to ensure that safety features are maintained.

## **Dangerous Procedure Warnings**

Warnings, such as the example below, precede potentially dangerous procedures throughout this manual. Instructions contained in the warnings must be followed. You should also employ all other safety precautions that you deem necessary for the operation of the equipment in your operating environment.

Warning example:

**Warning:** Dangerous voltages, capable of causing death, are present in this equipment. Use extreme caution when handling, testing, and adjusting.



## Caring for Environment

The following information is provided to enable regulatory compliance with the European Union (EU) Directive 2002/96/EC Waste Electrical and Electronic Equipment (WEEE) when using Motorola equipment in EU countries.

### Disposal of Motorola equipment in EU countries

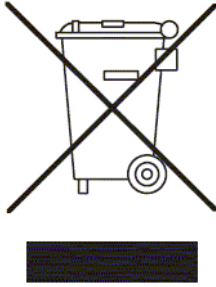

Please do not dispose of Motorola equipment in landfill sites. In the EU, Motorola in conjunction with a recycling partner will ensure that equipment is collected and recycled according to the requirements of EU environmental law.

Please contact the Customer Network Resolution Center (CNRC) for assistance. The 24 hour telephone numbers are listed at

<http://mynetworksupport.motorola.com>

Select **Customer Network Resolution Center contact information**.

Alternatively if you do not have access to CNRC or the internet, contact the Local Motorola Office.

### Disposal of Motorola equipment in non-EU countries

In non-EU countries, dispose of Motorola equipment in accordance with national and regional regulations.

## RoHS Compliance

The W24 product meets the European Union directive for RoHS compliance.

The RoHS compliance is subject to a declaration of conformity that may be viewed upon request.



## **Limitation of Liability**

The Products are not designed, intended, or authorized for use as components in systems intended for surgical implant into the body; in other applications intended to support or sustain life; for the planning, construction, maintenance, operation or use of any nuclear facility; for the flight, navigation, communication of aircraft or ground support equipment; or in any other application in which the failure of the Product could create a situation where personal injury or death may occur.

If CUSTOMER should use any Product or provide any Product to a third party for any such use, CUSTOMER hereby agrees that MOTOROLA is not liable, in whole or in part, for any claims or damages arising from such use, and further agrees to indemnify and hold MOTOROLA harmless from any claim, loss, cost or damage arising from such use.

EXCEPT AS SPECIFICALLY STATED ABOVE, THE PRODUCTS ARE PROVIDED "AS IS" AND MOTOROLA MAKES NO OTHER WARRANTIES EXPRESS, IMPLIED, STATUTORY, OR OTHERWISE REGARDING THE PRODUCTS. MOTOROLA SPECIFICALLY DISCLAIMS ANY IMPLIED WARRANTIES OF MERCHANTABILITY AND FITNESS FOR A PARTICULAR PURPOSE, OR ARISING FROM A COURSE OF DEALING OR USAGE OF TRADE.

Under no circumstances shall MOTOROLA be liable to CUSTOMER or any other party for any costs, lost revenue or profits or for any other special, incidental or consequential damages, even if MOTOROLA has been informed of such potential loss or damage. And in no event shall MOTOROLA's liability to CUSTOMER for damages of any nature exceed the total purchase price CUSTOMER paid for the Product at issue in the dispute, except direct damages resulting from patent and/or copyright infringement, which shall be governed by the "INDEMNITY" Section of this Agreement.

The preceding states MOTOROLA's entire liability for MOTOROLA's breach or failure to perform under any provision of this Agreement.

## **Warranty Notification**

Motorola guarantees to you, the original purchaser, the OEM Module and accessories which you have purchased from an authorized Motorola dealer (the "Products"), to be in conformance with the applicable Motorola specifications current at the time of manufacture for a term of [1] year from date of purchase of the Product(s) (Warranty Term).

You must inform Motorola of the lack of conformity to the applicable specifications of any of the Products within a period of two (2) months from the date on which you detect a defect in material, workmanship or lack of conformity and in any event within a term not to exceed the Warranty Term, and must immediately submit the Product for service to Motorola's Authorized Repair or Service Center. Motorola shall not be bound by Product related statements not directly made by Motorola nor any warranty obligations applicable to the seller.

A list of the Motorola Call Center numbers is enclosed with this Product.

During the Warranty term, Motorola will, at its discretion and without extra charge, as your exclusive remedy, repair or replace your Product which does not comply with this warranty; or failing this, to reimburse the price of the Product but reduced to take into account the use you have had of the Product since it was delivered. This warranty will expire at the end of the Warranty Term.

This is the complete and exclusive warranty for a Motorola OEM Module and accessories and in lieu of all other warranties, terms and conditions, whether express or implied.

Where you purchase the product other than as a consumer, Motorola disclaims all other warranties, terms and conditions express or implied, such as fitness for purpose and satisfactory quality.

In no event shall Motorola be liable for damages nor loss of data in excess of the purchase price nor for any incidental special or consequential damages\* arising out of the use or inability to use the Product, to the full extent such may be disclaimed by law.



This Warranty does not affect any statutory rights that you may have if you are a consumer, such as a warranty of satisfactory quality and fit for the purpose for which products of the same type are normally used under normal use and service, nor any rights against the seller of the Products arising from your purchase and sales contract.

(\*)including without limitation loss of use, loss of time, loss of data, inconvenience, commercial loss, lost profits or savings.

## **How to Get Warranty Service?**

In most cases the authorized Motorola dealer which sold and/or installed your Motorola OEM Module and original accessories will honor a warranty claim and/or provide warranty service. Alternatively, for further information on how to get warranty service please contact the Motorola M2M Data Module Customer Support Center..

## **Claiming**

In order to claim the warranty service you must return the OEM Module and/or accessories in question to Motorola's Authorized Repair or Service Center in the original configuration and packaging as supplied by Motorola. Please avoid leaving any supplementary items like SIM cards. The Product should also be accompanied by a label with your name, address, and telephone number; name of operator and a description of the problem.

In order to be eligible to receive warranty service, you must present your receipt of purchase or a comparable substitute proof of purchase bearing the date of purchase. The module should also clearly display the original Motorola Serial Number (MSN). Such information is contained with the Product.

You must ensure that all and any repairs or servicing is handled at all times by a Motorola Authorized Service Center in accordance with the Motorola Service requirements.

In some cases, you may be requested to provide additional information concerning the maintenance of the Products by Motorola Authorized Service Centers only, therefore it is important to keep a record of any previous repairs, and make them available if questions arise concerning maintenance.

## **Conditions**

This warranty will not apply if the type or serial numbers on the Product has been altered, deleted, duplicated, removed, or made illegible. Motorola reserves the right to refuse free-of-charge warranty service if the requested documentation can not be presented or if the information is incomplete, illegible or incompatible with the factory records.

Repair, at Motorola's option, may include reflashing of software, the replacement of parts or boards with functionally equivalent, reconditioned or new parts or boards. Replaced parts, accessories, batteries, or boards are warranted for the balance of the original warranty time period. The Warranty Term will not be extended. All original accessories, batteries, parts, and OEM Module equipment that have been replaced shall become the property of Motorola.

Motorola does not warrant the installation, maintenance or service of the products, accessories, batteries or parts.

Motorola will not be responsible in any way for problems or damage caused by any ancillary equipment not furnished by Motorola which is attached to or used in connection with the Products, or for operation of Motorola equipment with any ancillary equipment and all such equipment is expressly excluded from this warranty.



When the Product is used in conjunction with ancillary or peripheral equipment not supplied by Motorola, Motorola does not warrant the operation of the Product/peripheral combination and Motorola will not honor any warranty claim where the Product is used in such a combination and it is determined by Motorola that there is no fault with the Product. Motorola specifically disclaims any responsibility for any damage, whether or not to Motorola equipment, caused in any way by the use of the OEM Module, accessories, software applications and peripherals (specific examples include, but are not limited to: batteries, chargers, adapters, and power supplies) when such accessories, software applications and peripherals are not manufactured and supplied by Motorola.

### ***What is Not Covered by the Warranty***

This warranty is not valid if the defects are due to damage, misuse, tampering, neglect or lack of care and in case of alterations or repair carried out by unauthorized persons.

The following are examples of defects or damage not covered by this product warranty

1. Defects or damage resulting from use of the Product in other than its normal and customary manner.
2. Defects or damage from misuse, access to incompatible sources, accident or neglect.
3. Defects or damage from improper testing, operation, maintenance, installation, adjustment, unauthorized software applications or any alteration or modification of any kind.
4. Breakage or damage to antennas unless caused directly by defects in material or workmanship.
5. Products disassembled or repaired other than by Motorola in such a manner as to adversely affect performance or prevent adequate inspection and testing to verify any warranty claim.
6. Defects or damage due to range, coverage, availability, grade of service, or operation of the wi-Fi Provider.
7. Defects or damage due to moist, liquid or spills of food.
8. Control unit coil cords in the Product that are stretched or have the modular tab broken.
9. All plastic surfaces and all other externally exposed parts that are scratched or damaged due to customer normal use.

Depending on operating conditions and your usage habits, wear and tear might take place of components including mechanical problems related to Product housing, paint, assembly, sub-assemblies, displays and keyboards and any accessories which are not part of the Product's in-box configuration. The rectification of faults generated through wear and tear and the use of consumable items like batteries beyond their Optimum Performance Time as indicated in the product manual is considered to be your responsibility and therefore Motorola will not provide the free Warranty repair service for these items

### ***Installed Data***

Please make and retain a note of all data you have inserted into your Product for example names, addresses, phone numbers, user and access codes, notes etc. before submitting your Product for a Warranty service as such data may be deleted or erased as part of the repair or service process.

Please note if you have downloaded material onto your Product, these may be deleted or erased as part of the repair process or testing process. Motorola shall not be responsible for such matters.

The repair or testing process should not affect any such material that was installed by Motorola on your Product as a standard feature.

### ***Out of Warranty Repairs***

If you request Motorola to repair your Product any time after the Warranty term or where this warranty does not apply due to the nature of the defect or fault, then Motorola may in its discretion carry out such repairs subject to you paying Motorola its fees for such a repair or it may refer you to an authorized third party to carry out such repairs.



## Revision History

### Manual Number

6802984C95

### Manual Title

Module Hardware Description

### Version Information

The following table lists the manual version, date of version, and remarks about the version required.

Version	Date Issue	Remarks
X1	February 18, 2008	Initial Draft
X2	March 4, 2008	Added RF remarks/corrections
X3	March 5, 2008	
X4	March 5, 2008	Antenna installation; standards; <a href="#">Regulatory</a>
X5	May 01, 2008	
X6	May 14, 2008	Regulatory Statements added
X7	May 15, 2008	Regulatory Statements added (Fcc)
X8	May 19, 2008	Warranty section updated, Chapter 5 (Service & Support updated; BT Coexistence signals description added; Host Interface Specifications updated
X9	May 25, 2008	Specifications table updated Notes added in Power ON/OFF Operation chapters
X10	May 29, 2008	ESD related notes added in "Regulatory Statement (Safety)" and "Precautions"
X11		



## Chapter 1: Introduction

W24 is a self contained Wi-Fi module, supporting IEEE 802.11b/g systems in 2.4GHz band. W24 enables IP connectivity to any host device. It is ideal for enabling M2M applications to achieve secure, high speed throughput and access to IP networks via 802.11b/g wireless LANs or even via Cellular network when connected to G24 GSM/GPRS module family

W24 integrates an operating system, drivers and communication stack, wide assortment of proven security protocols, NATs for management purposes, built-in web server for managing the device via web and inherent built-in device firewall.

### Operation setup

W24 supports two operating setup options: stand alone and stack assembly with G24.

#### Stand Alone Configuration

Stand Alone configuration consists of a W24 as a stand alone Wi-Fi module that is controlled by the host.

In this setup the W24 70 pin host connector (bottom connector) is used for interfacing with the W24.

Figure 1-1 below illustrates the W24 Stand Alone configuration.

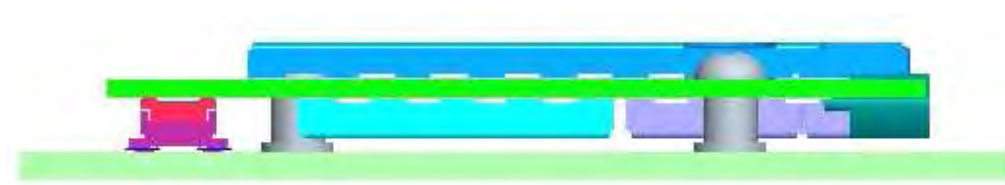

Figure 1-1: W24 Stand Alone setup

#### Stacked Configuration

Stack assembly setup consists of a G24 that is mounted on top of W24 in piggy-back configuration. In this configuration, the W24 70-pin host connector (bottom connector) is used for interfacing with the host board, while the G24 is connected to the W24 cellular 70-pin interface connector (top connector).



Figure 1-2 below illustrates the W24 & G24 stack assembly setup

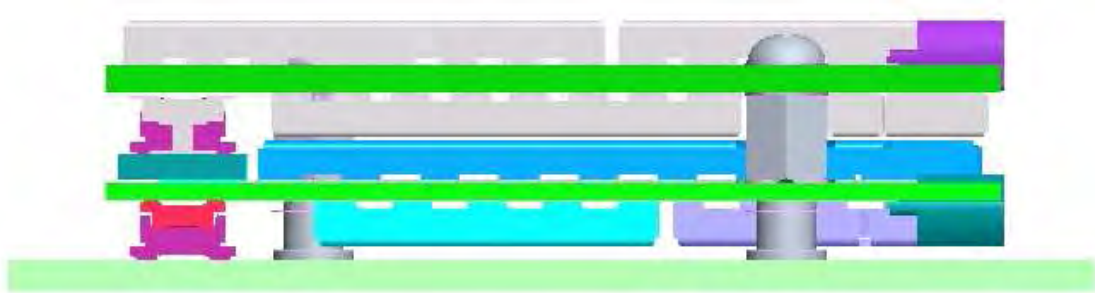

Figure 1-2: W24 + G24 Stack Assembly Setup



## Product Specifications

**Important:** For safety regulations and requirements, see “Regulatory Requirements” on page x, “Regulatory Statement (Safety)” on page x and “Antenna and Transmission Safety Precautions” on page x in “Preface”.

**Note:** Motorola reserves the right to change the specifications without prior notice.

**Table 1-1: Product Specifications**

Product Features	
	Adds Wi-Fi capability to G24 platforms WLAN (802.11.b/g) Operates in the 2.4GHz ISM band Ad-Hoc WLAN Support Local WEB server
Physical Characteristics	
<b>Size:</b>	45.2 x 24.4 x 7.25 mm 45.2 x 24.4 x 5.5 mm (stand alone model)
<b>Mounting:</b>	Two Ø2.4 mm holes for M2 screws
<b>Weight:</b>	10 grams
Environmental	
<b>Operational temperature:</b>	-20°C to +60°C
<b>Storage temperature:</b>	-40°C to +85°C
Performance	
<b>Operating voltage:</b>	3.3 - 4.2 V
<b>Current consumption:</b>	250mA
<b>Maximum Tx peak output power:</b>	25 dBm according to 47 CFR 15.247 (b) (3)& RSS-210 Section A8.4
Interfaces	
<b>Connectors:</b>	70-pin, board-to-board (host interface) 70-pin, board-to-board (G24 interface) not available on all models MMCX RF Connector
<b>Serial Ports:</b>	<b>USB:</b> USB full-speed device port, Rev. 2.0 USB full-speed host port, Rev. 2.0 <b>Host UART Interface:</b> BR from 2400 bps to 230.4 kbps Extended bit rates, up to 3Mbps <b>Modem UART Interface:</b> BR from 2400 bps to 230.4 kbps Extended bit rates, up to 3Mbps
Data Features	
<b>Data Throughput</b>	<b>Via UART:</b> 400 kbps upload / 1 Mbps download (security disabled) 100 kbps upload / 300 kbps download (security enabled) <b>Via USB:</b> 800 kbps upload/download (security disabled) 100 kbps upload/ 300 kbps download (security enabled)
Control/Status Indicators:	
<b>Wakeup</b>	
<b>Antenna Detect</b>	
<b>Reset_N (Ready)</b>	
<b>TX enable</b>	(available only when coupled with G24)



<b>AT Command Set</b>	AT+i <sup>TM</sup> commands (ConnectOne's AT+i <sup>TM</sup> ) is an extension to the standard AT command set that allows programming, monitoring, communication activation and control. W24 Does not support the standard AT Commands set.
<b>Accessories</b>	
<b>Developer Kit</b>	

## Regulatory Approvals

The W24 module has been tested and approved under the standards and regulations listed below:

- FCC
- **CE (DOC)**
- IC
- EMC
- Safety
- R&TTE

**Important:** The following paragraphs must be addressed by the integrator to ensure their host is in compliance to the W24 FCC grant and/or the FCC grant of the host device and the G24 (where applicable).

### CFR 47 Part 15.19 specifies Label Requirements

The following text may be on the product, user's manual, or container.

This device complies with Part 15 of the FCC Rules. Operation is subject to the following two conditions:

- (1) this device may not cause harmful interference, and
- (2) this device must accept any interference received, including interference that may cause undesired operation.

### CFR 47 Part 15.21 Information to user

The user's manual or instruction manual for an intentional or unintentional radiator shall caution the user that changes or modifications not expressly approved by the party responsible for compliance could void the user's authority to operate the equipment. In cases where the manual is provided only in a form other than paper, such as on a computer disk or over the Internet, the information required by this section may be included in the manual in that alternative form, provided the user can reasonably be expected to have the capability to access information in that form.

### CFR 47 Part 15.247

Operation within the bands 2400 to 2483.5 MHz

### CRF 47 Part 15.247 & 15.205 & 15.209

Spurious Radiated Emissions, Restricted Bands

### CFR 47 Part 15.107 & part 15.109



NOTE: This equipment has been tested and found to comply with the limits for a Class B digital device, pursuant to Part 15 of the FCC Rules. These limits are designed to provide reasonable protection against harmful interference in a residential installation. This equipment generates, uses and can radiate radio frequency energy and, if not installed and used in accordance with the instructions, may cause harmful interference to radio communications. However, there is no guarantee that interference will not occur in a particular installation. If this equipment does cause harmful interference to radio or television reception, which can be determined by turning the equipment off and on, the user is encouraged to try to correct the interference by one or more of the following measures:

- Reorient or relocate the receiving antenna.
- Increase the separation between the equipment and receiver.
- Connect the equipment into an outlet on a circuit different from that to which the receiver is connected.
- Consult the dealer or an experienced radio/TV technician for help.

## European Union Directives Conformance Statement

Hereby, Motorola declares that this product is in compliance with



- The essential requirements and other relevant provisions of Directive 1999/5/EC
- All other relevant EU Directives

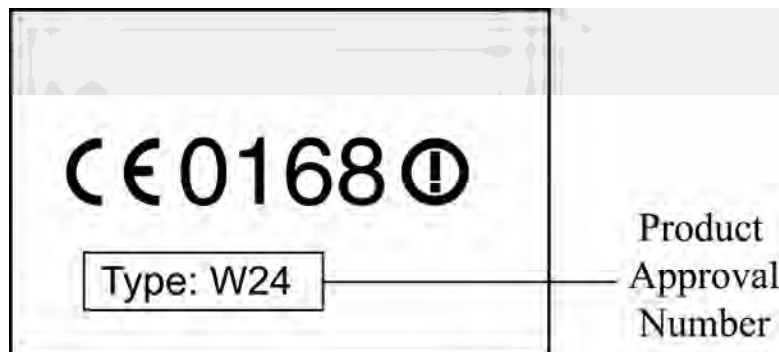

The above gives an example of a typical Product Approval Number.

You can view your product's Declaration of Conformity (DoC) to Directive 1999/5/EC (the R&TTE Directive) at [www.motorola.com/rtte](http://www.motorola.com/rtte) - to find your DoC, enter the product Approval Number from your product's label in the "Search" bar on the Web site.





## Power Management Block

- Power-up/down control circuit
- Power Management IC (PMIC).
- 2 LDO regulators

## RF Block

- Wireless LAN Module which includes:
  - Power Amplifier
  - RF Transceiver
  - RF switch
  - Balun
  - MAC Processor
  - MAC EEPROM
- 26 MHz crystal
- RF Antenna connector



## Operating Modes

W24 incorporates several operating modes. Each operating mode is different in the active features and interfaces.

Table 2-1 summarizes the general characteristics of the W24 operating modes and provides general guidelines for operation.

**Table 2-1: W24 Operating Modes**

Mode	Description	Features
<b>Not Powered</b>	VCC supply is disconnected.	The W24 is Off. Any signals connected to the interface connector must be set low or tri-state.
<b>Powered off</b>	Valid VCC supply. All W24 voltage regulators are disabled.	The W24 Interfaces and circuits are powered down. Only the power up/down control circuit is monitoring the IGN and ON_N signals. Any signals connected to the interface connector must be set low or tri-stated.
<b>Off-mode</b>	Valid VCC supply. W24 powered down by ON_N, while IGN set high. All W24 voltage regulators are active.	The W24 Interfaces and circuits are powered down. The CPU is running at 32kHz and monitoring IGN and ON_N signals. Any signals connected to the interface connector must be set low or tri-stated.
<b>Sleep</b>	RESET_N signal is high. CTS_N signal is disabled.	The W24 is in low power mode. The application interfaces are disabled, but, W24 continues to monitor the Wi-Fi network.
<b>Deep Sleep Mode</b>	RESET_N signal is high. CTS_N signal is disabled.	The W24 enters deep sleep mode if it cannot find an AP that it can register to. It wakes up periodically to rescan and try to register. If the AP is found, it exits the deep sleep mode. If the AP cannot be found/registered to, it goes back to deep sleep mode – during that time it disables the RF section and does not monitor the Wi-Fi network..
<b>Idle</b>	RESET_N signal is disabled (high). CTS_N and DSR_N signals are enabled (low).	The W24 is fully active, connected to the Wi-Fi network and ready to communicate. This is the default power-up mode.
<b>"Airplane" Mode</b>	RF block disabled	The W24 interfaces are fully active, but its RF section is disabled.
<b>Tx</b>	RESET_N signal is high. TXEN_N signal is toggling.	A Wi-Fi data transmission is in progress. When data transmission terminates, W24 returns to the last operating state (Idle or Sleep).



## Power Supply

The W24 power supply must be a single external DC voltage source of 3.3V to 4.2V. In order to support the stacked configuration, i.e. when G24 cellular module is coupled on the W24 module, the power supply must be able to sustain the required voltage level during a GSM transmit burst current surge, which may reach 2.0A.

The W24 host interface connector has 8 contacts for the main power supply, as described in [Table 2-2](#). All these contacts must be used for proper operation.

**Table 2-2: Power Supply Signals**

Pin Number	Signal Name	Description
1-4	GND	Main ground connection for W24 module.
5-8	VCC	DC supply input for W24 module. $V_{IN} = 3.3V$ to $4.2V$ $I_{RMS} = 250mA$ during transmission (Stand Alone) $I_{RMS} = 900mA$ during multi-slot transmission (with G24) $I_{MAX} = 2.5A$ during transmit bursts

## Power Supply Design

Special care must be taken when designing the power supply of the W24 in stacked configuration. The single external DC power source indirectly supplies all the digital and analog interfaces, but also directly supplies the G24 RF power amplifier (PA). Therefore, any degradation in the power supply performance, due to losses, noises or transients, will directly affect the G24 performance. The burst-mode operation of the GSM transmission and reception, draws instantaneous current surges from the power supply, which causes temporary voltage drops of the power supply level. The transmission bursts consume the most instantaneous current, and therefore cause the largest voltage drop. If the voltage drops are not minimized, the frequent voltage fluctuations may degrade the W24 and G24 performance.

[Figure 2-2](#) illustrates the power supply behavior during GSM transmission (Stack Assembly).

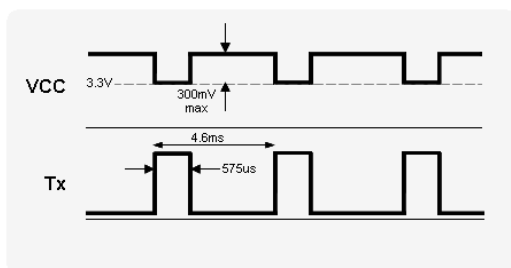



## Power Consumption

Table 2-4 specifies typical W24 current consumption ratings in various operating modes. The current ratings refer to the overall W24 current consumption over the  $V_{CC}$  supply.

**Table 2-4: W24 Current Ratings**

Parameter	Description	Conditions	Min	Typ	Max	Unit
$I_{OFF}$	Powered off	$3.3V < V_{CC} < 4.2V$		10	100	$\mu A$
$I_{OFF\_MODE}$	Powered off with IGN hi	$3.3V < V_{CC} < 4.2V$ $IGN < 0.8V$		4	6	mA
$I_{DEEPSLEEP}$		$3.3V < V_{CC} < 4.2V$		4	6	mA
$I_{SLEEP}$	Idle mode	$3.3V < V_{CC} < 4.2V$		9	12	mA
$I_{IDLE}$	Idle mode	$3.3V < V_{CC} < 4.2V$		125	150	mA
$I_{AIRPLANE}$	Airplane mode	$3.3V < V_{CC} < 4.2V$		45	60	mA
$I_{TX}$		$3.3V < V_{CC} < 4.2V$		190	250	mA



## Power On/Off Operation

The W24 power on consists of two primary phases:

Initial power up is hardware controlled by the Power-up/down circuit which monitors two power-up control signals: ON\_N and IGN. If any of these two signals is asserted, the Power-up/down circuit will enable Voltage regulators and the power management IC. They will provide valid supply voltages to the processor which will start to boot.

The second phase is SW controlled. Processor checks the state of ON\_N and IGN signals and if any of them is asserted, the CPU takes control over the voltage regulators and power management IC and holds them enabled.

Power down is controlled by SW – Once valid power-down condition occurs, CPU will release the signal which keeps the regulators and power management enabled, thus causing the W24 to power down. If this happened while IGN signal is still asserted, the regulators will remain active, and the unit will enter "Off mode".

W24 state is indicated at the interface connector by the hardware output signals RESET\_N. The RESET\_N signal indicates whether W24 is powered on or off. When the RESET\_N is low, W24 is powered-off. When it is high, W24 is powered-on.

**Note:** As the power down process in W24 is SW controlled, if an unexpected reset occurs, the module will power down if it is not being held by the IGN signal. Therefore, although both ways of powering up/down are provided to user, we recommend using IGN as a sole power up/down control signal. By using IGN as a control signal, user insures that in case of an unexpected reset, the unit automatically turns on. If the IGN was not asserted, the unit will remain "OFF" after a reset.

**Important:** Do not operate the W24 out of its electrical or environmental limits. Refer to the specifications chapter for details of these limits.

## Turning the W24 On

When the W24 power supply is stable above the minimum operating level and W24 is powered off, all of its circuits are disabled.

When W24 is turned on, by any of the methods described below, it will first perform an automatic initialization. When the initialization has completed, W24 resumes normal operation (stand alone mode), or turns on the G24 module (stacked modules) and resumes normal operation.

During the internal system-test process W24 may toggle several interface signals, which are visible to the application. These signals do not represent any valid state or data, and should be ignored by the customer application until the system-test has completed.

Valid Turn-on reasons are:

- ON\_N asserted low for 0.5s
- IGNITION asserted

**Note:** During FW upgrades (reflashing) make sure to power-up the W24 by IGN.

## Turning the W24 On Using ON\_N

The ON\_N input signal is set high by an internal pull-up resistor whenever a power supply is applied to W24. Therefore, it is recommended to operate this signal using an open collector/drain circuit connection.



Asserting the ON\_N signal low for a minimum of 500 milliseconds (0.5 seconds) and a maximum of 1.5 seconds will cause the W24 to turn-on.

Asserting the ON\_N signal low for more than 1.5 seconds may cause the W24 to interpret the signal as a power-off command, and turn off immediately after turning on.

Figure 2-4 illustrates the power-on process using the ON\_N signal.

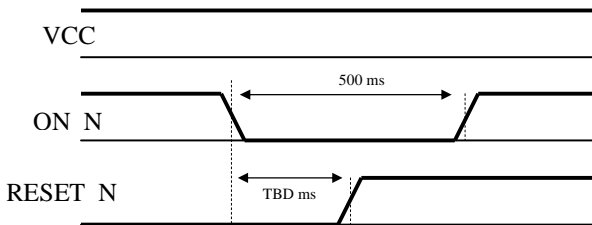

Figure 2-4: ON\_N Power On Timing

## Turning the W24 On Using IGN

The IGN input signal must be set low when not used. To turn on W24, this signal must be asserted high. The IGN signal must remain high for the duration of the W24 operation. W24 powers down when the IGN signal is returned to its low state.

**Important:** It is recommended to place a pull-down resistor in the customer application, on the IGN signal. A 100 kOhm resistor, or less, is acceptable.

Figure 2-5 illustrates the power-on process using the IGN signal.

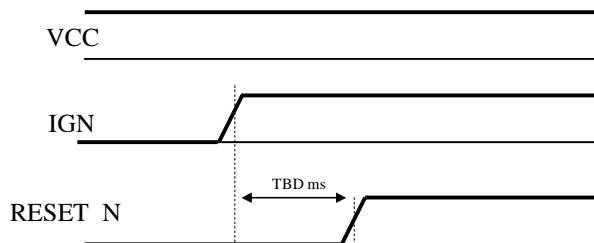

Figure 2-5: IGN Power On Timing

## Turning the W24 Off

There are several ways to turn the W24 off:

- Asserting the ON\_N signal low for a minimum of 2 seconds.
- Setting the IGN signal low.
- Turning the W24 Off using AT+iMRST

**NOTE:** If the unit was powered up by ON\_N signal, W24 will ignore attempt to turn it off by setting the IGNITION to low.

**Note:** Attempts to power off the module within first 8 seconds from powerup should not be attempted. Unit will ignore such attempts.



## Turning the W24 Off Using ON\_N

The ON\_N signal is internally pulled-up when power is applied to W24. Asserting the ON\_N signal low for a minimum of 2 seconds will turn W24 off. This will initiate a normal power-off process, which includes G24 power down (stack configuration) and disabling of all applications interfaces (UART, USB, etc.).

Figure 2-6 illustrates the power-off timings when using the ON\_N signal.

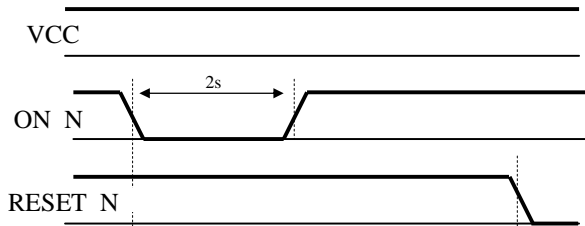

Note that if the unit was powered up by IGN, and it's being turned off by ON\_N, the unit will enter "Off mode", and not power off

Figure 2-6: ON\_N Power Off Timing

## Turning the W24 Off Using IGN

The IGN signal may be used to power off W24 if the unit was powered-up by the IGN signal. When the IGN signal is set low, W24 will turn off. This will initiate a normal power-off process, which includes G24 power down (stack configuration) and disabling of all applications interfaces (UART, USB, etc.).

The IGN signal will not power off W24 before 30 seconds have elapsed since W24 was powered-on. This delay mechanism is implemented to protect W24 from unexpected transients on the IGN line during power up, particularly when applying vehicle cranking waveforms.

Figure 2-7 illustrates the power-off timings when using the IGN signal.

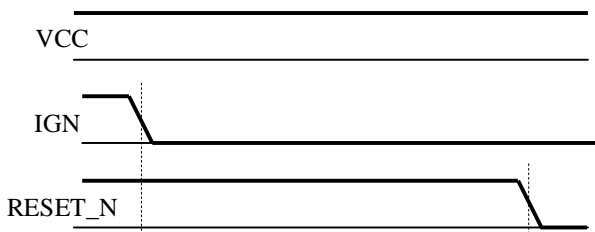

Figure 2-7: IGN Power Off Timing

## Power Loss shutdown

A low power shutdown occurs when W24 senses the external power supply is below the minimal operating limit. The module will respond by powering down automatically without notice. This form of power-down is not recommended for regular use since the unexpected power loss may result in loss of data.



## Turning the W24 Off Using AT+iMRST

The AT+iMRST command initiates a W24 system reset operation, which powers off the W24. This Command emulates the ON\_N signal operation for W24 power off.

Note: In Stacked configuration, AT+iMRST powers down W24 only. It does not power down the G24 or similar modem module.



## Low Power Mode

The W24 supports optional low power modes, called Sleep Mode and Deep Sleep Mode, in which it operates with minimum functionality, and therefore draws significantly less current. During Sleep Mode the W24 network connection is not lost. W24 continues to monitor the network constantly for any incoming data.

During low power mode, all of the W24 interface signals are inactive and are kept in their previous state, prior to activating low power mode. To save power, all the W24 internal clocks and circuits are shut down, and therefore serial communications are disabled.

In cases where no Access Point can be found at W24 power-up, W24 will enter the Deep Sleep Mode. During Deep Sleep Mode, network connection does not exist. W24 will periodically come out of the Deep Sleep Mode, to attempt to locate APs. If the search is not successful, the module will return to the Deep Sleep Mode.

## Activating Low Power Mode

By default, the W24 powers on in Idle mode. In this mode, all the W24 interfaces and features are functional and the module is fully active. Sleep mode is activated by setting the AT+iPSE>0.

When the WAKEUP\_N signal is disabled (high), and no data is present on the serial interface or incoming from the WiFi network, and no internal system task is running, W24 will enter Sleep mode.

When in Sleep mode, the W24 disables all its serial interfaces (USB and UARTs), and disable the VBUS output signal of the cellular connector (stack configuration).

The W24 continues to respond to both external and internal interrupts.

The following conditions must be met for the W24 to enter Sleep mode:

- WKUPL\_N signal is disabled (high).
- AT+ iPSE and AT+ iS102 parameter values are not 0.
- For Example:
  - AT+ iPSE = 1 activates low power mode after 1 second of inactivity.
  - AT+ iPSE = 5 activates low power mode after 5 seconds of inactivity.
  - AT+ iPSE = 0 disables low power mode (default).
- A time interval of AT+ iS100 milliseconds has passed since the last wakeup event (AT+ iS100 parameter value is not 0).
- AT+ iWLPS parameter value is not 0, so the Wi-Fi chip is in automatic power save mode.
- No host command is currently being processed.
- No WPA process is currently active. For example, scanning or handshake.
- Carrier lost handling is not in process.
- No data is waiting to be transmitted over any of the active sockets.
- No data is waiting to be sent in SerialNET mode.

For more information about AT+ iS100 and AT+ iS102 parameters, see the following sections.

**Important:** W24 will not enter Sleep mode in any case when data is present on the serial interface or incoming from the Wi-Fi network, or an internal system task is running. Only when processing of a pending external or internal system task has completed, W24 will enter Sleep mode according to the AT+iPSE command settings.



## Serial Interface During Low Power Mode

During low power mode the W24 serial interfaces are disabled.

The W24 wakes up periodically from low power mode to monitor the network for data. After this short paging is completed, W24 returns to low power mode. During this short awake period, the serial interfaces are enabled and communications with the module is possible.



## Terminating Low Power Mode

To bring W24 back from the sleep mode, WKUPI\_N needs to be asserted (set low). The W24 Sleep mode is enabled or disabled by the AT+iPSE command. To permanently terminate the W24 Sleep mode, the AT+iPSE=0 command is used. W24 does not enter Sleep mode until an AT+iPSE>0 command is sent.

**Important:** During power save mode the W24 internal clocks and circuits are disabled, in order to minimize power consumption. When terminating the power saving mode, and switching to Idle mode, W24 requires a minimal delay time to reactivate and stabilize its internal circuits before it can respond to application data. This delay is typically **5 milliseconds**. The delay guarantees that data on the serial interface is not lost or misinterpreted.

## Temporary Termination of Low Power Mode

Temporary termination of low power mode occurs when W24 switches from Sleep mode to Idle mode for a defined period, and then returns automatically to Sleep mode.

Low power mode may be terminated temporarily by several sources, some of which are user initiated and others are initiated by the system.

## Using the WKUPI\_N signal

The WKUPI\_N signal is an active low input, that is set high by default. By asserting this signal low the application can wake-up W24 from low power mode and switch to Idle mode.

W24 will remain in Idle mode, awake and fully active, as long as WKUPI\_N signal remains low. When this signal is disabled and set high again, W24 will return to Sleep mode automatically, according to the AT+iPSE settings (see [Figure 2-10](#)).

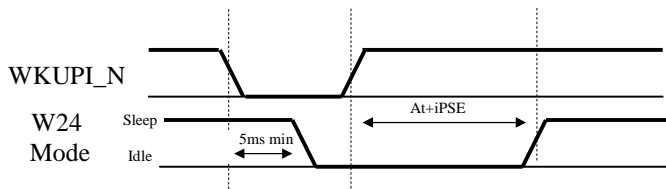

**Figure 2-10: WKUPI\_N Signal Operation**

The WKUPI\_N signal is the recommended method to temporarily wake-up G24 from low power mode. It provides the application full control of the G24 operating mode and guarantees that data on the serial interface will not be lost or misinterpreted.



## Using the WKUPO\_N signal

The WKUPO\_N signal is an active-low W24 output that is asserted high by default. By asserting this signal low, the host can be waked up by W24. WKUPO\_N alerts the host that W24 exits from Sleep mode into Idle mode due to network activity (see [Figure 2-11](#)).

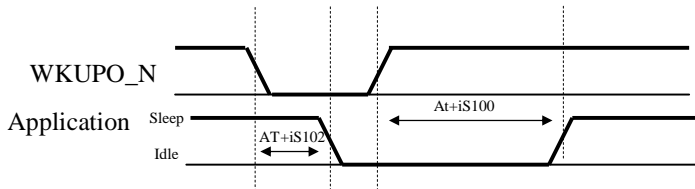

**Figure 2-11: WKUPO\_N Signal Operation**

The AT+iS102 parameter defines the delay time, in milliseconds, that W24 waits when in SerialNET mode, after asserting the WKUPO\_N signal, and before sending data on the host interface. This delay is required to allow the application enough time to re-activate from low power mode and switch to normal mode. If S102=0, which is the default value, the WKUPO\_N signal and mechanism is disabled. In other words, W24 will never assert the WKUPO\_N signal. AT+iS100 defines the minimal time interval, in milliseconds, that W24 waits before asserting WKUPO\_N after de-asserting it. In other words, WKUPO\_N will not assert the WKUPO\_N signal if the time that had passed from the previous de-assertion of this signal is not at least the duration specified by the S100 parameter. This time interval is required to avoid frequent unnecessary wakeup events and consequent S102 delays.

The S100 parameter is relevant only if S102>0, which enables the WKUPO\_N signal operation.



## Incoming Network Data

During low power mode, W24 continues monitoring the Wi-Fi network for any incoming data. When W24 receives an indication from the network that data is available, it automatically wakes up from low power mode to alert the application. When W24 has completed to process all the tasks related to the incoming data, it will automatically return to low power mode according to the AT+iEPS settings.

Depending on the type of network indication and the application settings, W24 may operate in several methods, which are configurable by AT commands, to alert the application of the incoming data:

- Enable the WKUPO\_N signal to wake-up the application from low power.
- Send data to the application over the serial interface.

## Data on the Serial interface

While W24 is temporarily awake in Idle mode, data may be transmitted on the serial interface. In case data is being transmitted in any direction, W24 will not return to low power mode. This is regardless of the original wake-up reason or source. W24 will remain awake while data is transferred.

Only when the serial interface transfer is completed and the data has been processed, W24 will return to low power mode automatically, according to the AT+iPSE settings (see [Figure 2-11](#)).

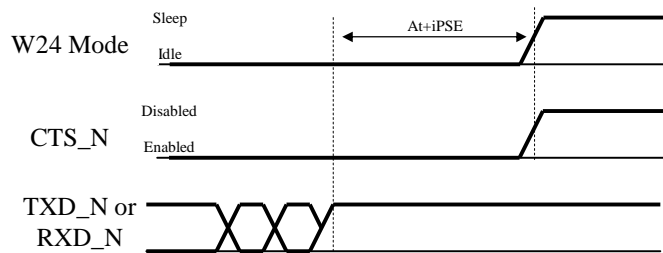

**Figure 2-11: Serial Interface Data**

## Permanent termination of Low Power Mode

The W24 low power mode is enabled and disabled by the AT+iPSE command.

To permanently terminate the W24 low power mode, the AT+iPSE = 0 command must be used.

Setting AT+iPSE = 0 disables the currently active low power mode and switches W24 to Idle mode.

W24 will not return to low power mode until an AT+iPSE > 0 commands is set again.

This command can be sent only when the serial interface is active.

In case the serial interface is disabled, it must first be activated before sending this command. To reactivate the serial interface, a temporary termination of the low power mode is required, as described in [“Temporary Termination of Low Power Mode”](#) on page [21](#).

Following the temporary low power mode termination, the serial interface will activate and the AT+iPSE = 0 command can be received by W24.



## Deep Sleep Mode

In case that W24 cannot locate an active access point or cannot register to it, W24 will enter the deep sleep mode.

During Deep Sleep Mode, network connection does not exist. W24 will periodically come out of the Deep Sleep Mode, to attempt to locate APs. If the search is not successful, the module will return to the Deep Sleep Mode.

The time between consecutive attempts to locate an AP is set by the AT+iWLSI command.



## Serial Interfaces

W24 includes three completely independent serial communications interfaces, which may be used by the application for several purposes.

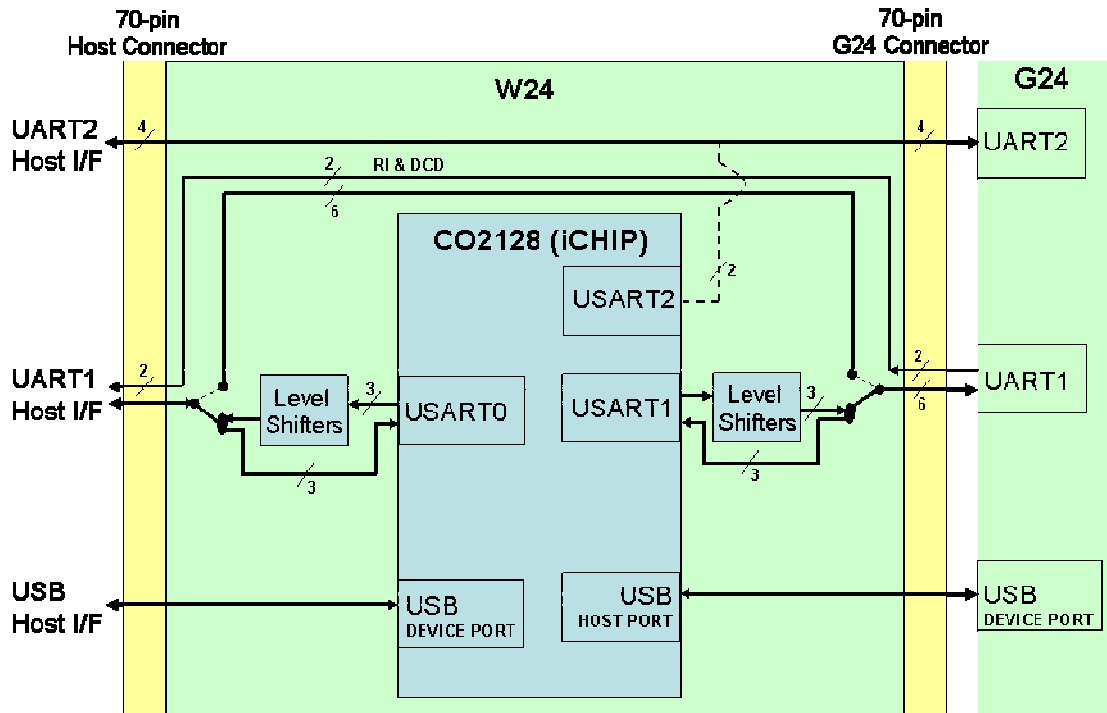

### Primary UART (UART1)

The W24 primary UART is a standard 8-signal bus. The primary UART is used for all the communications with W24 – AT+i commands interface, Wi-Fi data, and G24- AT command Interface (stacked configuration), programming and software upgrades.

The UART signals are active low CMOS level signals. For standard RS232 communications with a PC, an external transceiver is required.

W24 is defined as a DCE device, and the user application is defined as the DTE device. These definitions apply for the UART signals naming conventions, and the direction of data flow, as described in [Figure 2-12](#).

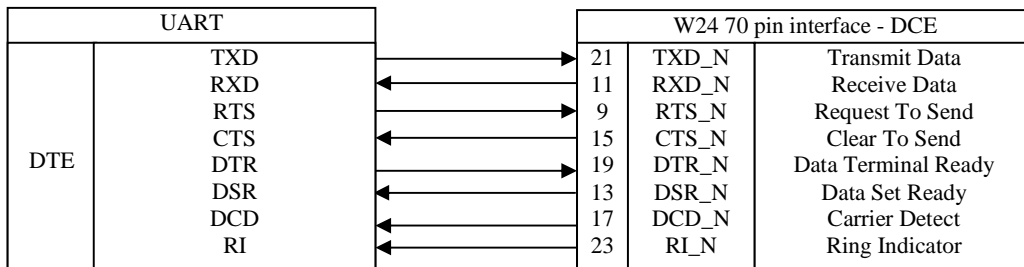

Figure 2-12:UART1 Interface Signals



The W24 primary UART supports the following standard baud rates 2400, 4800, 9600, 19200, 38400, 57600, 115200, 230400, as well as the extended high speed rates: 1Mbps, 1.5Mbps and 3Mbps. Auto baud rate detection is supported for baud rates up to 115200 bps. All flow control handshakes are supported: hardware, software, or none. Parity bit and Stop bit definitions are also supported. The UART default port configuration is 8 data bits, 1 stop bit and no parity, with hardware flow control and auto baud rate detect enabled.

Primary UART is defined for 3 different HW models: standard, stand alone and JAVA models. In the standard model. Primary UART is connected directly to W24 processor. 'AT+i' standard command shall be executed by the W24, while 'AT' commands that are for the G24 primary UART (stacked configuration), will be diverted by the W24 processor to the G24 interface connector, and will be executed by the G24.

In the JAVA model, where the G24 JAVA model function as W24 Host application, all UART commands shall be diverted to the G24 interface connector (by different HW wiring), and the G24 will execute them

**Important:** The G24 UART will not send data over the serial interface in case the DTR\_N and/or RTS\_N input signals are disabled (set high). Therefore, regardless of the handshake method, it is still required to enable these signals for proper operation, by asserting them low.

**NOTE:** Add pull-up resistors (22-100K) on all UART input signals that can be left in an undefined state (Hi-Z). The resistors should pull to the VREF voltage level.

## Secondary UART (UART2)

W24 incorporates Secondary UART interface intended to support G24 UART2 interface, in stacked configuration. The interface consists of the following pins:

**Table 2-5: Secondary UART Interface Signals**

Pin Number	Pin Name	Description
29	RXD2	Receive Data
31	TXD2	Transmit Data
33	RTS2	Request To Send
35	CTS2	Clear To Send

The above signals are routed from 70-pin host connector to G24 70-pin connector via W24. They are not internally connected to W24 circuits. If the W24 will be used as stand alone only, the above pins should be left open.

For more details on implementing a secondary interface for use with G24, please refer to the "*Motorola G24 Developer's Guide - Module Hardware Description*"



## USB Device Interface

W24 incorporates a standard Universal Serial Bus (USB) interface. The interface consists of the following pins:

**Table 2-6: USB Device Interface Signals (at Host connector)**

Pin Number	Pin Name	Description
10	USB_VBUS	USB bus power
12	USB_DP	USB bus serial data
14	USB_DN	USB bus serial data

The W24 USB electrical interface and protocol conform to the USB 2.0 full-speed specifications. W24 is defined as a USB device on the 70-pin Host Connector. This interface does not support hub or host functionality. USB Device may be used for standard communications with W24, as done through the UART interface.

## USB Host Interface (Stack configuration only)

W24 incorporates USB Host interface intended to support G24 USB interface, in stacked configuration. The interface consists of the following pins:

**Table 2-6: USB Host Interface Signals (at G24 connector)**

Pin Number	Pin Name	Description
10	USB_VBUS	USB bus power
12	USB_DP	USB bus serial data
14	USB_DN	USB bus serial data

The W24 USB Host electrical interface and protocol conform to the USB 2.0 full-speed specifications. USB may be only used for standard communications between W24 and G24 (stacked configuration only), as done through the UART interface. Setting USB Host communication is enabled by the AT+iHIF=5 command.

### **IMPORTANT:**

W24 relies on the host to provide the USB\_VBUS voltage, for both USB device and USB host interfaces. Therefore, if only USB host interface is to be used, or if host interface is going to be used when the device USB interface is inactive, make sure to provide the valid USB\_VBUS voltage on the **Host Connector**.

For more details on setting a USB interface for use with G24, please refer to the "*Motorola W24 Programmer's Guide – At+i Programmers Manual Description*"

Note: the maximum length of the W24 USB signals is 1m.



## SIM Interface

W24 incorporates SIM interface intended to support G24 SIM interface, in stacked configuration. The interface consists of the following pins:

**Table 2-5: SIM Interface Signals**

Pin Number	Pin Name	Description
44	SIM_RST_N	Active low SIM reset signal
46	SIM_CLK	SIM Clock
48	SIM_VCC	SIM Voltage Supply
50	SIM_PD_N	Active low SIM card presence detection
52	SIM_DIO	Serial input and output data

The above signals are routed from 70-pin host connector to G24 70-pin connector via W24. They are not internally connected to W24 circuits. If the W24 will be used as stand alone only, the above pins should be left open.

For more details on implementing a SIM interface for use with G24, please refer to the "*Motorola G24 Developer's Guide - Module Hardware Description*"



## Audio Interface

W24 incorporates Audio interface intended to support G24 Audio interface, in stacked configuration. The interface consists of the following pins:

**Table 2-6: Analog Audio Interface Signals**

Pin Number	Pin Name	Description
55	HDST_INT_N	Headset detect interrupt
57	HDST_MIC	Headset microphone input
59	AGND	Audio ground
61	MIC	Microphone input
63	ALRT_N	Alert speaker inverted
65	ALRT_P	Alert speaker
67	SPKR_N	Speaker inverted
69	SPKR_P	Speaker

**Table 2-7: Digital Audio Interface Signals**

Pin Number	Pin Name	Description
18	PCM_DIN	Digital audio receive
20	PCM_DOUT	Digital audio transmit
22	PCM_CLK	Digital audio clock
24	PCM_FS	Digital audio clock

The above signals are routed from 70-pin host connector to G24 70-pin connector via W24. They are not internally connected to W24 circuits. If the W24 will be used as stand alone only, the above pins should be left open.

For more details on implementing a Audio interface for use with G24, please refer to the "*Motorola G24 Developer's Guide - Module Hardware Description*"



## **A/D Converter Interface**

W24 incorporates Analog to Digital Converter interface intended to support G24 ADC interface, in stacked configuration. The interface consists of the following pins:

**Table 2-8: ADC Interface Signals**

<b>Pin Number</b>	<b>Pin Name</b>	<b>Description</b>
37	ADC1	General purpose A/D
43	ADC2	General purpose A/D
47	ADC3	General purpose A/D

The above signals are routed from 70-pin host connector to G24 70-pin connector via W24. They are not internally connected to W24 circuits. If the W24 will be used as stand alone only, the above pins should be left open.

For more details on implementing a ADC interface for use with G24, please refer to the "*Motorola G24 Developer's Guide - Module Hardware Description*"



## Unused/Reserved Signals

W24 provides an interface to unused and reserved G24 signals, to enable their usage in the future. The signals are directly routed from 70-pin host connector to the 70-pin cellular connector. The above pins should be left open. Here is the summary interface consists of the following pins:

**Table 2-5: Internal Interface Signals**

Pin Number	Pin Name	Description
54	LCD_CS	N.C
56	LCD_SD	N.C
58	LCD_CLK	N.C
70	SPI_CS	N.C
62	SPI_INT_N	N.C
64	SPI_DIN	N.C
68	SPI_DOUT	N.C
66	SPI_CLK	N.C



## Controls and Indicators Interface

The W24 incorporates several interface signals for controlling and monitoring the module's operation. The following paragraphs describe these signals and their operation.

Table 2-9 gives a description of the controls and indicators signals.

**Table 2-9: Controls and Indicators**

Pin Number	Pin Name	Description
25	RESET_N	W24 system readiness output indicator. When high, W24 is operating.
27	VREF	2.75V regulated output. Supplies up to 100mA to the external circuits.
26	WKUPO_N	Host application wake-up signal indicator.
16	WKUPI_N	Device application wake-up signal control
41	ANT_DET	Antenna physical connection detect indicator.
39	TXEN_N	Transmission burst indication.
49	GPRS	GPRS/EGPRS coverage indicator
60	WIFI_LED_LCD_RS	WIFI Activity LED indicator
45	MSEL_UID	Mode Select

### Reset

The RESET\_N output signal indicates the W24's operating status. This signal is set high after power up, when G24 is operating. It is set low when W24 is powered off.

When the RESET\_N signal is low, the W24 interface signals are disabled and do not represent any valid data or state. Furthermore, any input signals connected to the W24 interface must be disabled (tri-state) or set low when RESET\_N is low.

### VREF Reference Regulator

The W24 incorporates a regulated voltage output, VREF. The regulator provides a 2.8V output for use by the customer application. This regulator can source up to 100mA of current to power any external digital circuits. **VREF voltage is present whenever the W24 is powered up, regardless of it's mode of operation.**

**Important:** The VREF regulator is powered from the W24's main voltage supply, and therefore any current sourced through this regulator originates from the W24 VCC supply.

The overall VCC current consumed by W24 is directly affected by the VREF operation. The W24 current consumption rises with respect to the current drawn from VREF.

**Table 2-10: VREF Specifications**

Parameter	Condition	Min	Typ	Max	Unit
V <sub>OUT</sub>	I <sub>OUT</sub> = 150mA	2.7	2.8	2.9	V
I <sub>OUT</sub>	Active mode		-	100	mA
Load regulation	I <sub>OUT</sub> = 1.0mA to 100mA	-	2	15	mV
Line Regulation	V <sub>in</sub> = V <sub>CC</sub> , I <sub>OUT</sub> = 1.0mA	-	1	10	mV



## Wakeup

For a detailed description regarding Wake up signal interface, please refer to this manual at “Low Power Mode” chapter, at “Using the WKUPI\_N signal” and “Using the WKUPO\_N signal” sections.

## Antenna Detection

The W24 incorporates an internal antenna detection circuit, which senses the physical connection and removal of a Wi-Fi antenna, as well as the cellular antenna, in case that a cellular module like G24 is stacked on the W24 .

In case of stacked configuration (W24 + G24), a removal of a single or both of the modules antennas, shall cause the antenna detect indicator to be set Low.

The antenna detection state is reported to the application through the ANT\_DET output signal, and may also be queried by the AT+iRP19 command.

The detection circuit senses DC resistance to ground on the G24 antenna connector.

A DC resistance below 100kOhm (+10%) is defined as a valid antenna connection, and the ANT\_DET output signal is set high.

## GPRS/EGPRS Detection

This signal is routed from 70-pin host connector to G24 70-pin connector via W24. It is not internally connected to W24 circuits. If the W24 will be used as stand alone only, this signal pin should be left open.

For more details on implementing a GPRS/EGPRS signal for use with G24, please refer to the "*Motorola G24 Developer's Guide - Module Hardware Description*"

## Transmission Indicator

This signal is routed from 70-pin host connector to G24 70-pin connector via W24. It is not internally connected to W24 circuits. If the W24 will be used as stand alone only, the signal pin should be left open.

For more details on implementing a GPRS/EGPRS signal for use with G24, please refer to the "*Motorola G24 Developer's Guide - Module Hardware Description*"

## Wi-Fi LED Indicator

Wi-Fi LED Indicator is an output which indicates the Wi-Fi activity. WIFI\_LED\_LCD\_RS signal is mapped on the pin 60 of the 70-pin Host Connector.

## Mode Select

This signal sets the W24 mode of operation. It should be left open for normal operation. If pulled to ground at power up for 3s, it forces a module in boot mode.



## General Purpose I/O

W24 incorporates 8 General Purpose I/O interface.  
The interface consists of the following pins:

**Table 2-8: GPIO Interface Signals**

Pin Number	Pin Name	Description
28	GPIO1	General purpose I/O
30	GPIO2	General purpose I/O
32	GPIO3	General purpose I/O
34	GPIO4 / BT_PRIORITY	General purpose I/O / Bluetooth coexistence indication
36	GPIO5 / BT_FREQ	General purpose I/O, Bluetooth coexistence indication
38	GPIO6 / BT_STATE	General purpose I/O, Bluetooth coexistence indication
40	GPIO7 / WL_ACTIVE	General purpose I/O, Bluetooth coexistence indication
42	GPIO8	General purpose I/O

In Stand alone configuration, GPIO pins 1 to 3 act as general purpose inputs.

GPIO pins 4 to 7 function as Bluetooth coexistence control/indicators for the W24 to use with a Blue-tooth interface in order to avoid RF collision between Blue-tooth and Wi-Fi transmission. There are 2, 3 or 4-wires coexistence configurations possible. Below is the functionality description of relevant signals:

Pin Name	Direction	
GPIO4 / BT_PRIORITY	I	In 2-Wires coexistence: When High, BT is transmitting or receiving high priority packets. In 3-Wires coexistence: When High, BT PA is on or BT is receiving data.
GPIO5 / BT_FREQ	I	This pin is not used for 2-wire and 3-wire Bluetooth coexistence scheme. This pin can be used for 4-wire interface if needed. This pin should either be left floating or be connected to ground.
GPIO6 / BT_STATE	I	Only used in 3-Wires coexistence. If Bluetooth is transmitting high priority data, the Bluetooth device shall send a 20 $\mu$ s pulse on this line right after BT_PRIORITY line has been asserted. After this pulse, BT_STATE will go LOW to indicate RX Priority Bluetooth transmission or HIGH to indicate TX Priority BT transmission.
GPIO7 / WL_ACTIVE	O	In 2-Wires coexistence: When High WLAN is transmitting or receiving packets. In 3-Wires coexistence: When Low, Bluetooth is allowed to transmit. When High, Bluetooth is not allowed to transmit. If Bluetooth is already transmitting packets when signal is asserted, then Bluetooth will shut off right after the current transaction is completed

GPIO8 is not used, and should be left open.

In a stacked configuration, all GPIO signals are routed from G24 to host, and are used as GPIO signals for G24 user application.

For more details on implementing a GPIO interface for use with G24, please refer to the "*Motorola G24 Developer's Guide - Module Hardware Description*"



## Antenna Interface

The W24 antenna connector is the RF interface to the WLAN network.

The antenna interface consists of an MMCX type connector, which has impedance matched to 50Ω at the relevant WLAN 802.11b/g frequencies.

The antenna or antenna application must be installed properly to achieve best performance.

Table 2-24 gives the antenna interface specifications

Parameter	Specification
WLAN 802.11b/g band	2400 MHz – 2483.5MHz
Max Gain + Cable loss	2.35 dBi
Impedance	50 Ω
VSWR	Less than 2 : 1

It is the Integrator's responsibility to design the antenna or antenna assembly used with the W24.

This will highly affect the RF performance of the W24 (signal quality, current consumption etc.).

The following guidelines should be followed:

- Make sure that the antenna or antenna assembly matches the Antenna Interface Specifications.
- Use low loss RF cable and connectors keeping cable runs to a minimum..
- In order to prevent mutual interference between the GSM and the WLAN antennas in stacked configuration, a minimum distance that provides a 30dB isolation is required. To achieve the required 30dB isolation between the antennas, a distance of about 7cm from each other should be kept when using a monopole isotropic antenna with 0dBi and appropriate return loss.
- the W24 module is only approved for use with following antenna: 2.4 GHz 3 dBi Reverse Polarity – SMA “Rubber Duck” Wireless LAN Antenna – Model HG2403RD-RSF from HyperLink Technologies. Any antennas of different type or higher gain require additional testing and FCC approval.



## Chapter 3: Electrical and Environmental Specifications

### Absolute Maximum Ratings

Table 3-1 gives the maximum electrical characteristics of the W24 interface signals.

**Caution:** Exceeding the values may result in permanent damage to the module.

**Table 3-1: Maximum Ratings**

Parameter	Condition	Min	Max	Unit
VCC Supply		-0.3	4.5	V
Digital Input Signals (Except for IGN, VBUS, USB_DP, USB_DN)	W24 powered on	-0.3	3.6	V
Analog Input Signals (Audio, A/D interfaces)	W24 powered on	-0.3		V
All Input Signals (Except for IGN, VBUS, USB_DP, USB_DN)	W24 powered off	-0.3		V
IGN signal		-0.3	16	V
VBUS signal		-0.3	5.25	V
USB_DP, USB_DN		-0.3	3.6	V



## Environmental Specifications

Table 3-2 gives the environmental operating conditions of the W24 module.

**Caution:** Exceeding the values may result in permanent damage to the module.

**Table 3-2: Environmental Ratings**

Parameter	Condition	Min	Max	Unit
Ambient Operating Temperature		-20	+60	°C
Storage Temperature		-40	+85	°C
ESD	At antenna connector			
	Contact	-8	+8	kV
	Air	-15	+15	



## Application Interface Specifications

Table 3-3 summarizes the DC electrical specifications of the host application interface connector signals. Table 3-4 summarizes the DC electrical specifications of the cellular modem (e.g. G24) interface connector signals.

**Important:** Interface signals that are not used by the customer application must be left unconnected. W24 incorporates the necessary internal circuitry to keep unconnected signal in their default state. Do not connect any components to, or apply any voltage on, signals that are not used by the application.

**Important:** It is recommended to place a pull-down resistor in the customer application, on the IGN signal. A 100kOhm resistor, or less, is acceptable.

**Important:** Signals that are defined as "Do Not Use", or DNU, must remain externally unconnected in any case. These signals are reserved for future use.

**Table 3-3: Host Interface Specifications**

Pin	Signal Name	Description	I/O	Active H/L	Internal PU/PD	Parameter	Conditions	Level			
								Min	Typ	Max	Units
<b>Power</b>											
1	GND	Ground									
2											
3											
4											
5	VCC	DC Power	I			V <sub>IN</sub> I <sub>MAX</sub> I <sub>OFF</sub>	VCC = 3.6 V	3.3	3.6 190 10	4.2 250 100	V mA μA
6											
7											
8											
<b>Control:</b>											
27	VREF	Reference regulator output	O			V <sub>out</sub>	I <sub>out</sub> <100mA	2.7	2.8	2.9	V
16	WKUPI_N	w24 wakeup input	I	L	15K PU	V <sub>IH</sub> V <sub>IL</sub>		2	0	3.15 0.8	V
26	WKUPO_N	Host wakeup output	O	L	15K PU	V <sub>OH</sub> V <sub>OL</sub>	I <sub>OUT</sub> <8mA	2.75		0.4	V
25	RESET_N	W24 Ready indication output	O	L	15K PU	V <sub>OH</sub> V <sub>OL</sub>	I <sub>OUT</sub> <8mA	2.75		0.4	V
53	ON_N	On/Off switch	I	L	100K PU	V <sub>OH</sub> V <sub>OL</sub>		2.75		0.4	V
51	IGN	Ignition input	I	H	80K PD	V <sub>IH</sub> V <sub>IL</sub>		2		0.4	V
39	TXEN_N	Transmit indicator	O	L	15K PU	V <sub>OH</sub> V <sub>OL</sub>	I <sub>OUT</sub> <8mA	2.75		0.4	V
41	ANT_DET	Antenna presence indicator	O	H	15K PU	V <sub>OH</sub> V <sub>OL</sub>	I <sub>OUT</sub> <8mA	2.75		0.4	V
49	GPRS	GPRS/ EGPRS coverage indicator	O	L	15K PU	V <sub>OH</sub> V <sub>OL</sub>	I <sub>OUT</sub> <8mA	2.75		0.4	V
<b>UART1</b>											



Pin	Signal Name	Description	I/O	Active H/L	Internal PU/PD	Parameter	Conditions	Level				
								Min	Typ	Max	Units	
21	TXD_N	UART1 TXD	I	L	15K PU	VIH VIL  VOL VOH	I <sub>OUT</sub> <8mA	2 -0.3	0	3.15 0.8  0.4	V	
11	RXD_N	UART1 RXD	O	L								
9	RTS_N	UART1 RTS	I	L								
15	CTS_N	UART1 CTS	O	L								
19	DTR_N	UART1 DTR	I	L								
13	DSR_N	UART1 DSR	O	L								
17	DCD_N	UART1 DCD	O	L								
23	RI_N	UART1 RI	O	L								
<b>UART2</b>												
29	RXD2	UART2 RXD	O	L	15K PU	VIH VIL  VOL VOH	I <sub>OUT</sub> <8mA	2 -0.3	0	3.15 0.8  0.4	V	
31	TXD2	UART2 TXD	I	L								
33	RTS2	UART2 RTS	I	L								
35	CTS2	UART2 CTS	O	L								
<b>USB</b>												
10	USB_VBUS	USB bus power	I	H					5.0	5.25	V	
12	USB_DP	USB bus serial data	I/O	H							V	
14	USB_DN	USB bus serial data	I/O	L							V	
<b>SIM CARD</b>												
50	SIM_PD_N	SIM presence detect	I			refer to G24 HW description XXXXXXXXXX	Stacked Configuration					
48	SIM_VCC	SIM supply	O									
44	SIM_RST_N	SIM reset	O									
52	SIM_DIO	SIM serial data	I/O									
46	SIM_CLK	SIM clock	O									
<b>Digital Audio</b>												
18	PCM_DIN	Digital audio receive	I			refer to G24 HW description XXXXXXXXXX	Stacked Configuration					
20	PCM_DOUT	Digital audio transmit	O									
22	PCM_CLK	Digital audio clock	O									
24	PCM_FS	Digital audio frame sync.	O									
<b>GPIO</b>												
28	GPIO1	General purpose I/O	I/O									
30	GPIO2	General purpose I/O	I/O									
32	GPIO3	General purpose I/O	I/O									
34	GPIO4	General purpose I/O	I/O									
36	GPIO5	General purpose I/O	I/O									
38	GPIO6	General	I/O									



Pin	Signal Name	Description	I/O	Active H/L	Internal PU/PD	Parameter	Conditions	Level				
								Min	Typ	Max	Units	
		purpose I/O										
40	GPIO7	General purpose I/O	I/O									
42	GPIO8	General purpose I/O	I/O									
<b>Audio</b>												
67	SPKR_N	Speaker inverted	O			refer to G24 HW description XXXXXXXXX	Stacked Configuration					
69	SPKR_P	Speaker	O									
63	ALRT_N	Alert speaker inverted	O									
65	ALRT_P	Alert speaker	O									
61	MIC	Microphone input	I									
59	AGND	Audio ground										
57	HDST_MIC	Headset microphone input	I									
55	HDST_INT_N	Headset detect interrupt	I									
<b>A/D</b>												
37	ADC1	General purpose A/D	I			refer to G24 HW description XXXXXXXXX	Stacked Configuration					
43	ADC2	General purpose A/D	I									
47	ADC3	General purpose A/D	I									
45	MSEL_UID	Mode Select	I			VIH VIL		2.0 -0.3		3.6 0.8	V	
<b>Display</b>												
54	CLI_CS	Do Not Use										
60	WIFI_LED_LCD_RS	Wi-Fi Activity Indicator	O			VOL VOH		2.75	3.15	0.4	V	
56	LCD_DATA	Do Not Use										
58	LCD_CLK	Do Not Use										
<b>Data Logger</b>												
70	SPI_CS	Do Not Use										
62	SPI_IRQ_N	Do Not Use										
64	SPI_DIN	Do Not Use										
68	SPI_DOUT	Do Not Use										
66	SPI_CLK	Do Not Use										



**Table 3-4: Cellular Modem (G24) Interface Specifications**

Pin	Signal Name	Description	I/O	Active H/L	Internal PU/PD	Parameter	Conditions	Level			
								Min	Typ	Max	Units
<b>Power</b>											
1	GND	Ground									
2											
3											
4											
5	VCC	DC Power	O			VIN IMAX IOFF	VCC = 3.6 V	3.3 TBD TBD	3.6 TBD TBD	4.2 TBD TBD	V A μA
6											
7											
8											
<b>Control:</b>											
27	G24_VREF	Reference regulator output	NC	N/A							
16	G24_WKUPI_N	w24 wakeup output	O	L	15K PU	VIH VIL		2 -0.3	0	3.15 0.8	V
26	G24_WKUPO_N	Host wakeup Output from G24	I	L	15K PU	VOH VOL	Iout<8mA	2.75		0.4	V
25	G24_RESET_N	G24 Reset signal output	I	L	15K PU	VOH VOL	Iout<8mA	2.75		0.4	V
53	G24_ON_N	G24 On/Off control signal	O	L	15K PU	VOH VOL		2.75		0.4	V
51	G24_IGN	Ignition input	O	H							
39	TXEN_N	Transmit indicator	I	L	15K PU	VOH VOL	Iout<8mA	2.75		0.4	V
41	G24_ANT_DET	Antenna presence indicator	I	H	15K PU	VOH VOL	Iout<8mA	2.75		0.4	V
49	GPRS	GPRS/ EGPRS coverage indicator	I	L	15K PU	VOH VOL	Iout<8mA	2.75		0.4	V
<b>UART1</b>											
21	TXD_N	UART1 TXD	O	L	15K PU	VIH VIL  VOL VOH	Iout<8mA	2 -0.3	0	3.15 0.8	V
11	RXD_N	UART1 RXD	I	L							
9	RTS_N	UART1 RTS	O	L							
15	CTS_N	UART1 CTS	I	L							
19	DTR_N	UART1 DTR	O	L							
13	DSR_N	UART1 DSR	I	L							
17	DCD_N	UART1 DCD	I	L							
23	RI_N	UART1 RI	I	L							
<b>UART2</b>											
29	RXD2	UART2 RXD	I	L	15K PU	VIH VIL  VOL VOH	Iout<8mA	2 -0.3	0	3.15 0.8	V
31	TXD2	UART2 TXD	O	L							
33	RTS2	UART2 RTS	O	L							
35	CTS2	UART2 CTS	I	L							
<b>USB</b>											
10	G24_USB_VBUS	USB bus power	O	H						5.25	V



Pin	Signal Name	Description	I/O	Active H/L	Internal PU/PD	Parameter	Conditions	Level				
								Min	Typ	Max	Units	
12	USB_DP	USB bus serial data	I/O	H								
14	USB_DN	USB bus serial data	I/O	L								
<b>SIM CARD</b>												
50	SIM_PD_N	SIM presence detect	O			refer to G24 HW description XXXXXXXXXX	Stacked Configuration					
48	SIM_VCC	SIM supply	I									
44	SIM_RST_N	SIM reset	I									
52	SIM_DIO	SIM serial data	I/O									
46	SIM_CLK	SIM clock	I									
<b>Digital Audio</b>												
18	PCM_DIN	Digital audio receive	O			refer to G24 HW description XXXXXXXXXX	Stacked Configuration					
20	PCM_DOUT	Digital audio transmit	I									
22	PCM_CLK	Digital audio clock	I									
24	PCM_FS	Digital audio frame sync.	I									
<b>GPIO</b>												
28	GPIO1	General purpose I/O	I/O									
30	GPIO2	General purpose I/O	I/O									
32	GPIO3	General purpose I/O	I/O									
34	GPIO4	General purpose I/O	I/O									
36	GPIO5	General purpose I/O	I/O									
38	GPIO6	General purpose I/O	I/O									
40	GPIO7	General purpose I/O	I/O									
42	GPIO8	General purpose I/O	I/O									
<b>Audio</b>												
67	SPKR_N	Speaker inverted	I			refer to G24 HW description XXXXXXXXXX	Stacked Configuration					
69	SPKR_P	Speaker	I									
63	ALRT_N	Alert speaker inverted	I									
65	ALRT_P	Alert speaker	I									
61	MIC	Microphone input	O									
59	AGND	Audio ground										
57	HDST_MIC	Headset microphone	O									



Pin	Signal Name	Description	I/O	Active H/L	Internal PU/PD	Parameter	Conditions	Level			
								Min	Typ	Max	Units
		input									
55	HDST_INT_N	Headset detect interrupt	O								
<b>A/D</b>											
37	ADC1	General purpose A/D	O			refer to G24 HW description XXXXXXXXXX	Stacked Configuration				
43	ADC2	General purpose A/D	O								
47	ADC3	General purpose A/D	O								
45	UID	Do Not Use									
<b>Display</b>											
54	CLI_CS	Do Not Use									
60	LCD_RS	Do Not Use									
56	LCD_DATA	Do Not Use									
58	LCD_CLK	Do Not Use									
<b>Data Logger</b>											
70	SPL_CS	Do Not Use									
62	SPL_IRQ_N	Do Not Use									
64	SPL_DIN	Do Not Use									
68	SPL_DOUT	Do Not Use									
66	SPL_CLK	Do Not Use									



## Chapter 4: Mechanical Specifications

### Board Dimensions

Figure 4-1 describes the W24 mechanical characteristics.

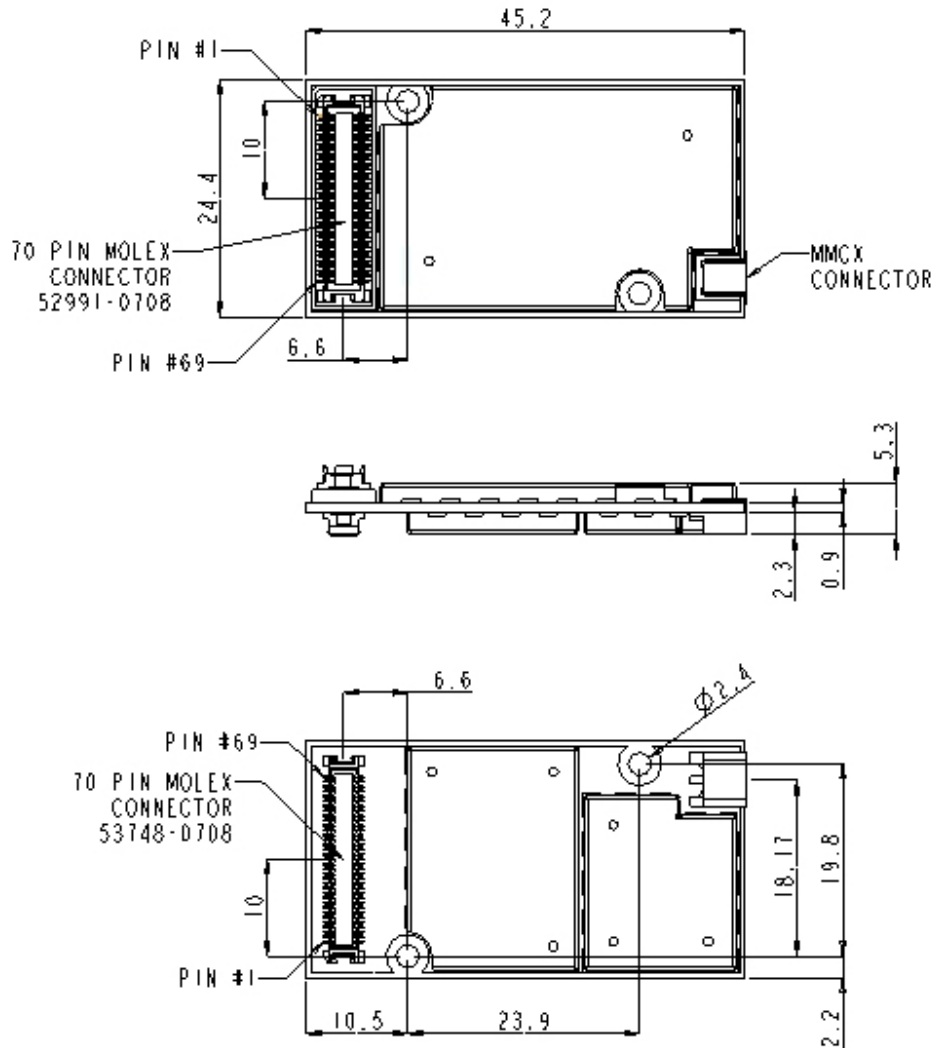

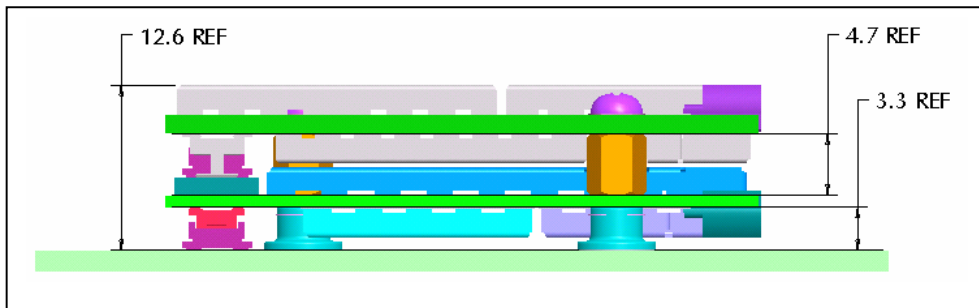
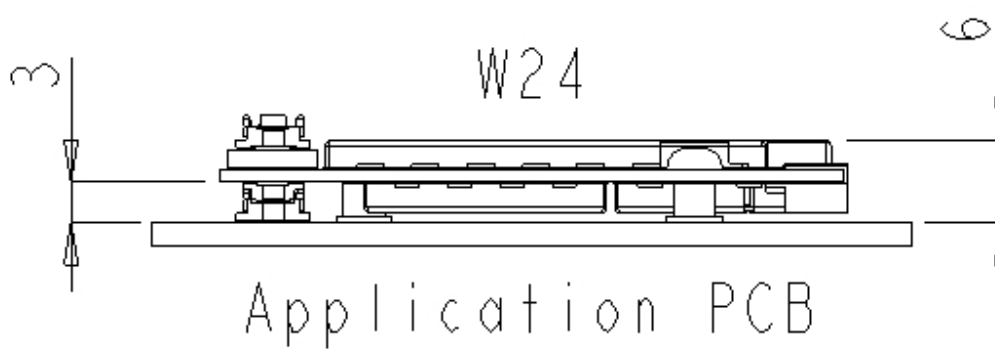
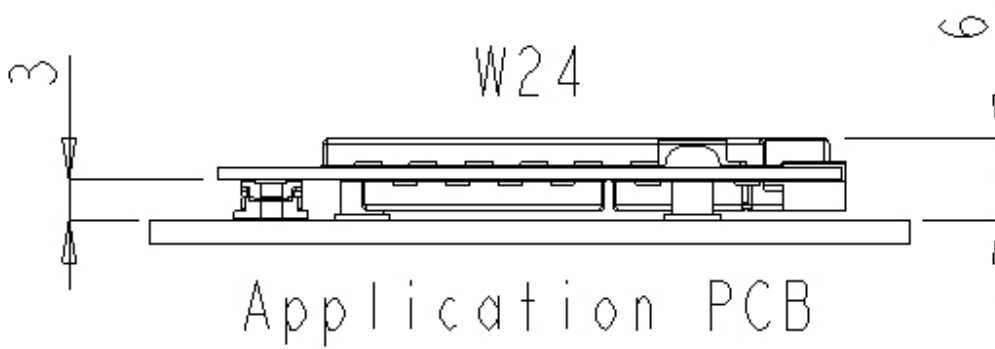



## Interface Connector Specifications

The W24 uses a single 70-pin, 0.5 mm pitch, board to board connector for the host interface:

**Table 4-1: W24 host interface connector options**

W24 Connector	Mating Connector	Stacking Height
Molex 53748-0708	Molex 52991-0708	3.0 mm

**Table 4-2: W24 cellular interface connector options**

W24 Connector	Mating Connector	Stacking Height
Molex 52991-0708	Molex 53748-0708	4.5 mm



## RF Connector Specifications

The W24 uses a standard MMCX receptacle connector for the radio interface. The connector is manufactured by Amphenol, PN MMCX6251S5.

Figure 4-4 shows the MMCX connector dimensions.

**INSERT FIGURE FROM G24 Manual**

### Figure 4-4: MMCX Connector Dimensions

Table 4-3 describes the W24 RF connector characteristics.

**Table 4-3: RF Connector Specifications**

Parameter	Specifications
Impedance	50 $\Omega$
Rated Voltage	335 V <sub>RMS</sub>
Contact Resistance	5 m $\Omega$ center contact 2.5 m $\Omega$ outer contact
Insulation Resistance	1000 M $\Omega$
Insertion Force	3.4 lbs maximum
Withdrawal Force	4.5 lbs maximum
Contact Retention Force	4 lbs maximum
Durability	500 mated cycles minimum

## Mating Connector

The RF mating connector should be a standard MMCX plug connector or cable assembly, which corresponds to the W24 MMCX connector specifications.

Any standard MMCX connector or application from different manufacturers may be mated with W24.

Plating requirement???

Such a cable assembly example is the Huber-Suhner PN 11\_MMCX-50-1-2/111\_OH, which is illustrated in Figure 4-5.

## **Insert Table/Figure from G24 Manual**

### Figure 4-5: MMCX Cable Assembly Example



## W24 Mounting

The W24 incorporates 2 mechanical holes for installing the module onto the application board. The holes are 2.4 millimeters in diameter, which accommodates several types of mechanical elements. Several mechanical approaches may be applied to mount and fasten W24 to the application board. Using M2 screws with suitable washers to mount the module onto spacers, a bracket or chassis is a recommended design.

Special attention must be paid to the area surrounding the W24 mounting holes. A grounding pad of 4.4 millimeters in diameter surrounds these holes. The diameter and area of this pad must not be exceeded by any mechanical or electrical element.

Several electrical components, which are not shielded, are located near the holes.

These components must not be in contact with the mounting elements or with other parts of the application board, and care must be taken to avoid any damage.

Figure 4-6 depict the W24 mounting area.

## INSERT DRAWING FROM G24 Manual

### Figure 4-6: W24 Mounting Area

### W24 Stand Alone Mounting

The holes are used for mechanical mounting of W24 to the application board but also for grounding support. Using conductive elements to install W24, significantly improves the overall grounding of the module and therefore improves the W24 performance and stability.

It is required to use screws or other mechanical elements to fasten W24 to the application board, but it is highly recommended to use conductive elements to improve the module's performance.

The preferred mounting screw head types are:

- "Allen" head with a chamfer - the best choice.
- "Torx" head - good.
- "Philips" head - may cause damage to nearby components.

Recommended screw type for static products: M2x4, PAN, SST

For portable products it's recommended put also washer M2 (max. dia. 4.0mm)

**Recommended Tighten screw torque 2.5 Lb\*In**



### W24 + G24 stack mounting

When G24 module is stacked on W24 and mounted on the host PCB, it is required to use hexagonal spacer (x2) between the two PCB's, see figure A-A

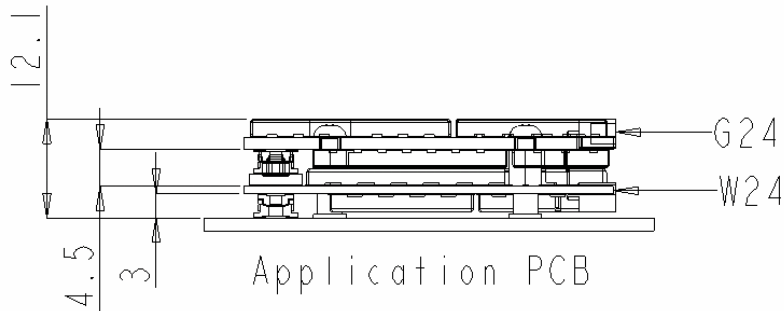

figure A-A

Recommended spacer dimension described in figure B-B  
 Recommended Tighten spacer torque 3.0 Lb\*In

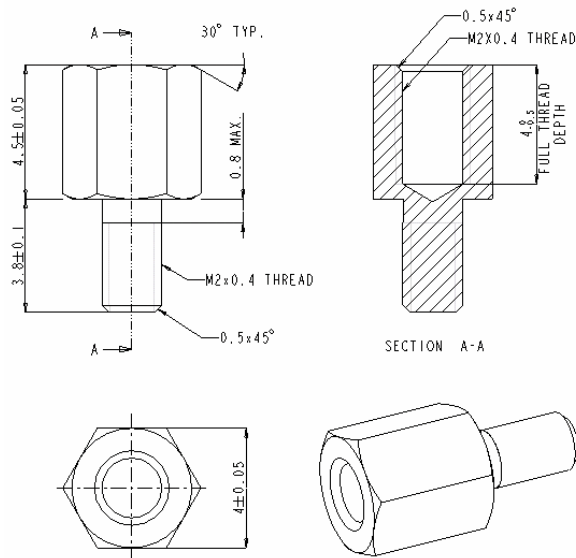

figure B-B



## Chapter 5: Support, Service and Troubleshooting

### Support

This section provides contact information for any possible queries that may arise, for example:

- Have questions?
- Having trouble getting the Developer Board set up?
- Technical questions?
- Configuration questions/problems?
- Technical operating problems?
- Need documentation?

### Who to Contact?

The **M2M Data Module Customer Support Center** is ready to assist you on integration issues.

**Direct Customer.** Use this following email address to contact customer assistance:

[M2M.CustomerCare@motorola.com](mailto:M2M.CustomerCare@motorola.com)

**Note:** The support services provided by Motorola are subject to the agreement between the customer and Motorola and may be at an additional charge to the customer. Motorola will inform the customer in advance of any such charge.

### Indirect Customer

Send requests to your distributor and not to Motorola help desk.

### Required Query Information

Every new call/problem report, directly from a Direct Customer or from a distributor, should be directed to the help desk email address noted above in “Who to Contact?”. It is recommended to report each individual issue in a separate email. The following information is required when reporting a problem:

- Customer name and address
- Customer contact information for this request, including:
  - Name
  - Telephone
  - Fax number
  - Mobile number
  - Email address
- Product name (W24)
- Software version of the unit (AT+i3 command) or model number
- PCB version (located on the PCB near the RF connector)
- Severity of the problem
- Problem description, including:
  - Setup Configuration (such as Developer Board, handset, host, connections, and so on)
  - Detailed scenario from startup
  - Log of all the commands and the responses, beginning from startup
- Answers to the following questions:
  - Was the same scenario tested on the Developer Board and the PC to reproduce the problem?
  - How many units do you have, and how many of them have this problem?



**MOTOROLA**

- How often does the problem recur?

In addition to the information requested above, send the following AT+i commands and the HyperTerminal log with the responses:

- **AT+iRP10** // to get the signal strength (RX level)
- **AT+iUID** // to read the unit MSN number
- **AT+i3** // to get the software version of the W24



## Service

The M2M field service department is ready to support you in following cases

- 1) To analyze the root cause of special defect.
- 2) To replace defected units within the 12 months warranty period.
- 3) To perform a mass reflash of the W24.

## Who to Contact?

### Direct Customer

Use this following email address to contact field service representative:  
**n2csfs01@motorola.com**

### Indirect Customer

Contact your distributor and not to Motorola field service department.

## Required Query Information

To apply for analysis or replacement of modules within the warranty period the following information must be provided.

- 1) Model
- 2) MSN (Motorola Serial Number)
- 3) Defect/Symptom for every unit (deeper details required for analysis)
- 4) Requester full information (Name, company, phone, email)

Populate all the above into an excel file and email it to the Field Service Department listed above.  
If all the required data will be provided an RMA will be issued to the customer within one business day  
The RMA will specify exactly to what destination the customer should send the units to and other references to be used for follow up.



## **Testing a Standalone Unit**

This section describes how to perform W24 functionality test, whose purpose is to:

- Introduce the user to the W24
- Explain how to work with the W24 unit
- Describe how to evaluate basic W24 features

The test setup provides a wide platform through which a W24 unit can be evaluated. The specific test procedure described below covers only a few of the W24's many features. Using this setup, you can perform several additional tests on the W24.

The test requires knowledge about the operation of the M2M Developer's Kit, terminal applications and AT and AT+i commands. Refer to relevant documentation for assistance.

To perform the test, you need the following:

- A W24 OEM wireless module unit
- A W24 Developer's Kit
- A desktop or laptop computer, which includes:
  - A free serial communications port (RS232)
  - A connected and active line modem (internal or external)
  - A terminal application (such as HyperTerminal)

For more information please refer to the W24 Service Manual.