



FCC TEST REPORT

REPORT NO.: FD120822C31
MODEL NO.: XT901
FCC ID: IHDP56NA1
RECEIVED: Aug. 22, 2012
TESTED: Aug. 28 ~ Oct. 18, 2012
ISSUED: Oct. 19, 2012

APPLICANT: Motorola Mobility, Inc.

ADDRESS: No. 1, Wang Jing East Road, Chao Yang District,
Beijing, 100102, P. R. China

ISSUED BY: Bureau Veritas Consumer Products Services (H.K.)
Ltd., Taoyuan Branch

LAB ADDRESS: No. 19, Hwa Ya 2nd Rd, Wen Hwa Tsuen, Kwei
Shan Hsiang, Taoyuan Hsien 333, Taiwan, R.O.C.

This report should not be used by the client to claim product certification, approval, or endorsement by TAF, NVLAP, NIST or any government agencies.



This report is for your exclusive use. Any copying or replication of this report to or for any other person or entity, or use of our name or trademark, is permitted only with our prior written permission. This report sets forth our findings solely with respect to the test samples identified herein. The results set forth in this report are not indicative or representative of the quality or characteristics of the lot from which a test sample was taken or any similar or identical product unless specifically and expressly noted. Our report includes all of the tests requested by you and the results thereof based upon the information that you provided to us. You have 60 days from date of issuance of this report to notify us of any material error or omission caused by our negligence, provided, however, that such notice shall be in writing and shall specifically address the issue you wish to raise. A failure to raise such issue within the prescribed time shall constitute your unqualified acceptance of the completeness of this report, the tests conducted and the correctness of the report contents. Unless specific mention, the uncertainty of measurement has been explicitly taken into account to declare the compliance or non-compliance to the specification

Table of Contents

RELEASE CONTROL RECORD.....	3
1 CERTIFICATION	4
2 SUMMARY OF TEST RESULTS	5
2.1 MEASUREMENT UNCERTAINTY	5
3 GENERAL INFORMATION	6
3.1 GENERAL DESCRIPTION OF EUT	6
3.2 DESCRIPTION OF TEST MODES	7
3.3 DESCRIPTION OF SUPPORT UNITS.....	8
3.4 CONFIGURATION OF SYSTEM UNDER TEST	9
4 TEST TYPES AND RESULTS	11
4.1 CONDUCTED EMISSION MEASUREMENT	11
4.1.1 LIMITS OF CONDUCTED EMISSION MEASUREMENT	11
4.1.2 TEST INSTRUMENTS.....	11
4.1.3 TEST PROCEDURES	12
4.1.4 DEVIATION FROM TEST STANDARD	12
4.1.5 TEST SETUP	12
4.1.6 EUT OPERATING CONDITIONS	13
4.1.7 TEST RESULTS	14
4.2 RADIATED EMISSION MEASUREMENT	18
4.2.1 LIMITS OF RADIATED EMISSION MEASUREMENT	18
4.2.2 TEST INSTRUMENTS.....	19
4.2.3 TEST PROCEDURES	21
4.2.4 DEVIATION FROM TEST STANDARD	21
4.2.5 TEST SETUP	22
4.2.6 EUT OPERATING CONDITIONS	22
4.2.7 TEST RESULTS	23
5 PHOTOGRAPHS OF THE TEST CONFIGURATION.....	31
6 INFORMATION ON THE TESTING LABORATORIES	32
7 APPENDIX A – MODIFICATION RECORDERS FOR ENGINEERING CHANGES TO THE EUT BY THE LAB	33



RELEASE CONTROL RECORD

ISSUE NO.	REASON FOR CHANGE	DATE ISSUED
FD120822C31	Original release	Oct. 19, 2012



1 CERTIFICATION

PRODUCT: Mobile Phone

MODEL NO.: XT901

BRAND: Motorola

APPLICANT: Motorola Mobility, Inc.

TESTED: Aug. 28 ~ Oct. 18, 2012

TEST SAMPLE: ENGINEERING SAMPLE

STANDARD: **FCC Part 15, Subpart B, Class B**

ICES-003:2012, Class B

ANSI C63.4:2009

The above equipment (Model: XT901) has been tested by **Bureau Veritas Consumer Products Services (H.K.) Ltd., Taoyuan Branch**, and found compliance with the requirement of the above standards. The test record, data evaluation & Equipment Under Test (EUT) configurations represented herein are true and accurate accounts of the measurements of the sample's EMC characteristics under the conditions specified in this report.

PREPARED BY : Ivonne Wu , **DATE :** Oct. 19, 2012
Ivonne Wu / Senior Specialist

APPROVED BY : David Liu , **DATE :** Oct. 19, 2012
David Liu / Senior Engineer

2 SUMMARY OF TEST RESULTS

The EUT has been tested according to the following specifications.

EMISSION			
Standard	Test Type	Result	Remarks
FCC Part 15, Subpart B, Class B ICES-003:2012, Class B	Conducted emission test	PASS	Meet the requirement of limit. Minimum passing margin is -11.16dB at 4.04688MHz.
	Radiated emission test (30MHz~40GHz)	PASS	Meet the requirement of limit. Minimum passing margin is -3.13dB at 480.01MHz.

2.1 MEASUREMENT UNCERTAINTY

Where relevant, the following measurement uncertainty levels have been estimated for tests performed on the EUT as specified in CISPR 16-4-2:

This uncertainty represents an expanded uncertainty expressed at approximately the 95% confidence level using a coverage factor of $k=2$.

Measurement	Frequency	Uncertainty
Conducted emission	150kHz ~ 30MHz	2.44 dB
Radiated emission	30MHz ~ 1GHz	4.12 dB
	Above 1GHz	2.26 dB

The listed uncertainties are the worst case uncertainty for the entire range of measurement. Please note that the uncertainty values are provided for informational purposes only and are not used in determining the PASS/FAIL results.

3 GENERAL INFORMATION

3.1 GENERAL DESCRIPTION OF EUT

PRODUCT	Mobile Phone
MODEL NO.	XT901
POWER SUPPLY	5.0Vdc (adapter or host equipment) 3.8Vdc (battery)
I/O PORT	Refer to users' manual
DATA CABLE	Refer to Note as below
ACCESSORY DEVICE	Refer to Note as below

NOTE:

1. The EUT's highest operating frequency is 2.4GHz.
2. The EUT contains following accessories.

AC Adapter	Brand Name	Motorola
	Model Name	DC4050US0301
	Power Rating	I/P:100-240Vac, 200mA; O/P: 5.1Vdc, 850mA
Battery	Brand Name	Motorola
	Model Name	EG30
	Power Rating	3.8Vdc, 1940/2000mAh
	Type	Li-ion
Earphone	Brand Name	Motorola
	Model Name	NA
	Signal Line Type	1.45 meter non-shielded cable without ferrite core
USB Cable	Brand Name	Motorola
	Model Name	NA
	Signal Line Type	1.05 meter non-shielded cable without ferrite core

3. The above EUT information is declared by manufacturer and for more detailed feature description, please refer to the manufacturer's specifications or user's manual.

3.2 DESCRIPTION OF TEST MODES

Test Mode	Test Condition
1	CDMA850 Idle + BT Idle + WLAN Idle + NFC Rx + MPEG4 + USB Cable + Adapter + Earphone + Battery
2	CDMA1900 Idle + BT Idle + WLAN Idle + NFC Rx + Camera + USB Cable + Adapter + Earphone + Battery
3	CDMA1700 Idle + BT Idle + WLAN Idle + NFC Rx + GPS Rx + USB Cable + Adapter + Earphone + Battery
4	LTE Band 2 Idle + BT Idle + WLAN Idle + NFC Rx + GPS Rx + USB Cable + USB Link + Earphone + Battery
5	LTE Band 4 Idle + BT Idle + WLAN Idle + NFC Rx + MPEG4 + USB Cable + Adapter + Earphone + Battery
6	LTE Band 5 Idle + BT Idle + WLAN Idle + NFC Rx + MPEG4 + USB Cable + Adapter + Earphone + Battery
7	LTE Band 12 Idle + BT Idle + WLAN Idle + NFC Rx + MPEG4 + USB Cable + Adapter + Earphone + Battery
8	LTE Band 25 Idle + BT Idle + WLAN Idle + NFC Rx + MPEG4 + USB Cable + Adapter + Earphone + Battery

Remark:

1. For conducted emission test, test mode 1 and test mode 4 were the worst case and only these modes were presented in this report.
2. For radiated emission test, test mode 1 and test mode 4 were the worst case and only these modes were presented in this report.

3.3 DESCRIPTION OF SUPPORT UNITS

The EUT has been tested as an independent unit together with other necessary accessories or support units. The following support units or accessories were used to form a representative test configuration during the tests.

NO.	PRODUCT	BRAND	MODEL NO.	SERIAL NO.	FCC ID
1	Universal Radio Communication Tester	R&S	CMU200	123112	NA
2	Wireless AP	BUFFALO	WBR2-G54	34059544811631	FDI-04600142-0
3	BLUETOOTH EARPHONE	ELECOM	LBT-MPHS400	NA	NA
4	24" LCD MONITOR	DELL	U2410	CN082WXD-72872-0 CR-06FL	FCC DoC Approved
5	MODEM	ACEEX	1414V/3	0401008257	IFAXDM1414
6	NOTEBOOK	DELL	PP05L	FPBCB1S	E2K24CLNS
7	MOUSE	DELL	M056U0	349004359	FCC DoC Approved
8	Wireless N Router	D-Link	DIR-615	F308188007995	NA
9	GPS simulator	T&E	GS-50	610493	NA
10	Radio Communication Analyzer	Anritsu	MT8820C	6201010284	NA
11	Printer	EPSON	B241A	FAPY139300	FCC DoC Approved

NO.	SIGNAL CABLE DESCRIPTION OF THE ABOVE SUPPORT UNITS
1	NA
2	NA
3	NA
4	1.8m D-Sub cable
5	1.5m braid shielded wire , DB25 & DB9 connector , w/o core.
6	NA
7	1.8m foil shielded wire, USB Connector, w/o core.
8	NA
9	NA
10	NA
11	1.8 m shielded cable, terminated with USB connector, w/o core.

NOTE:

1. All power cords of the above support units are non shielded (1.8m).
2. Items 1-2 and 8-10 acted as communication partners.
3. Items 4-11 were for test mode 4 only.

3.4 CONFIGURATION OF SYSTEM UNDER TEST

<Test Mode 1>

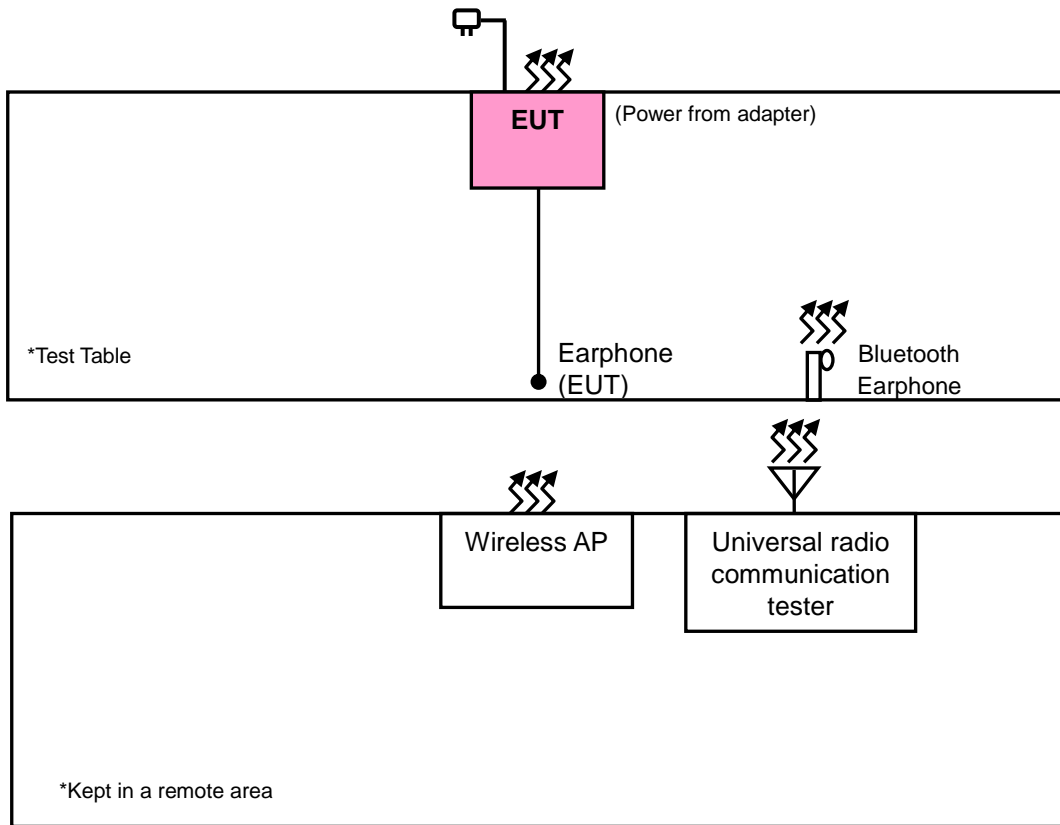

<Test Mode 4>

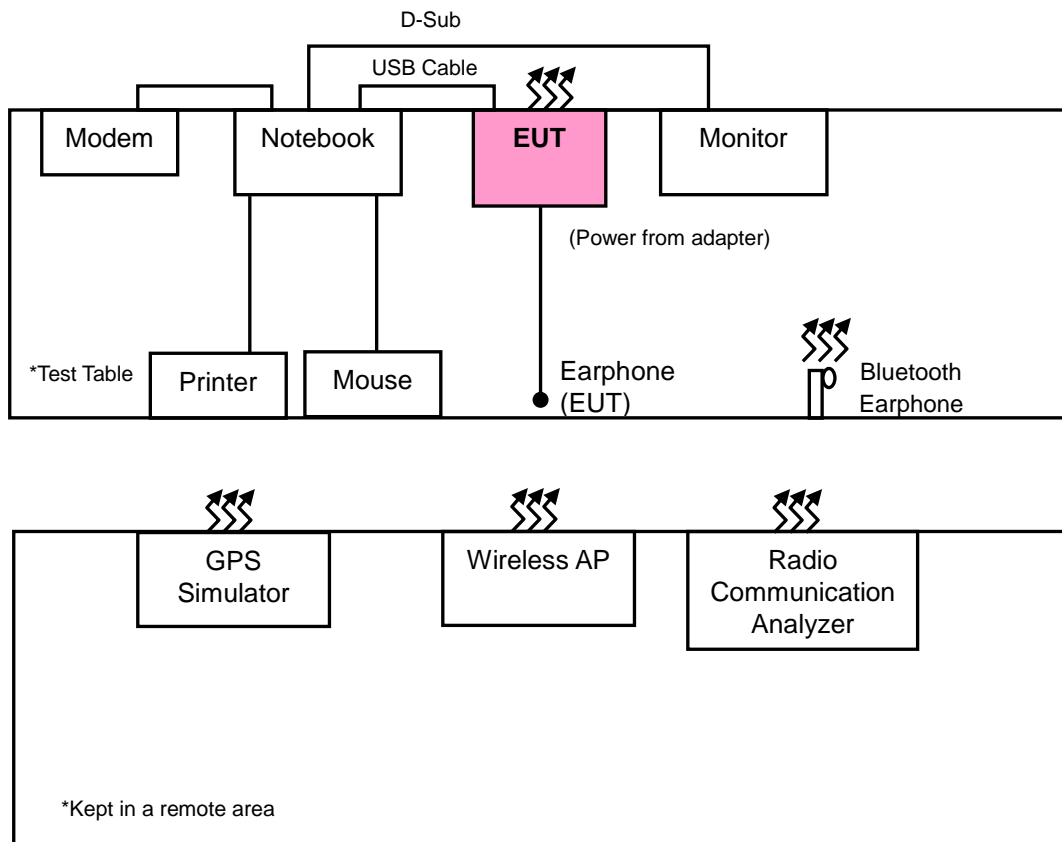

4 TEST TYPES AND RESULTS

4.1 CONDUCTED EMISSION MEASUREMENT

4.1.1 LIMITS OF CONDUCTED EMISSION MEASUREMENT

TEST STANDARD:

FCC Part 15, Subpart B (section: 15.107)

ICES-003:2012 Issue 5 (section: 6.1)

Frequency (MHz)	Class A (dBuV)		Class B (dBuV)	
	Quasi-peak	Average	Quasi-peak	Average
0.15-0.5	79	66	66-56	56-46
0.5-5	73	60	56	46
5-30	73	60	60	50

- NOTE:**
1. The lower limit shall apply at the transition frequencies.
 2. The limit decreases in line with the logarithm of the frequency in the range of 0.15 to 0.50 MHz.
 3. All emanations from a class A/B digital device or system, including any network of conductors and apparatus connected thereto, shall not exceed the level of field strengths specified above.

4.1.2 TEST INSTRUMENTS

DESCRIPTION & MANUFACTURER	MODEL NO.	SERIAL NO.	DATE OF CALIBRATION	DUE DATE OF CALIBRATION
Test Receiver ROHDE & SCHWARZ	ESCS30	100289	Nov. 19, 2011	Nov. 18, 2012
RF signal cable Woken	5D-FB	Cable-HYCO2-01	Dec. 29, 2011	Dec. 28, 2012
LISN ROHDE & SCHWARZ (EUT)	ESH2-Z5	100100	Dec. 30, 2011	Dec. 29, 2012
LISN ROHDE & SCHWARZ (Peripheral)	ESH3-Z5	100311	Jul. 06, 2012	Jul. 05, 2013
Software ADT	BV ADT_Cond_ V7.3.7.3	NA	NA	NA

- NOTE:**
1. The calibration interval of the above test instruments is 12 months and the calibrations are traceable to NML/ROC and NIST/USA.
 2. The test was performed in HwaYa Shielded Room 2.
 3. The VCCI Site Registration No. is C-2047.

4.1.3 TEST PROCEDURES

- a. The EUT was placed 0.4 meters from the conducting wall of the shielded room with EUT being connected to the power mains through a line impedance stabilization network (LISN). Other support units were connected to the power mains through another LISN. The two LISNs provide 50 ohm/ 50uH of coupling impedance for the measuring instrument.
- b. Both lines of the power mains connected to the EUT were checked for maximum conducted interference.
- c. The frequency range from 150 kHz to 30 MHz was searched. Emission levels under Limit - 20dB was not recorded.

4.1.4 DEVIATION FROM TEST STANDARD

No deviation.

4.1.5 TEST SETUP

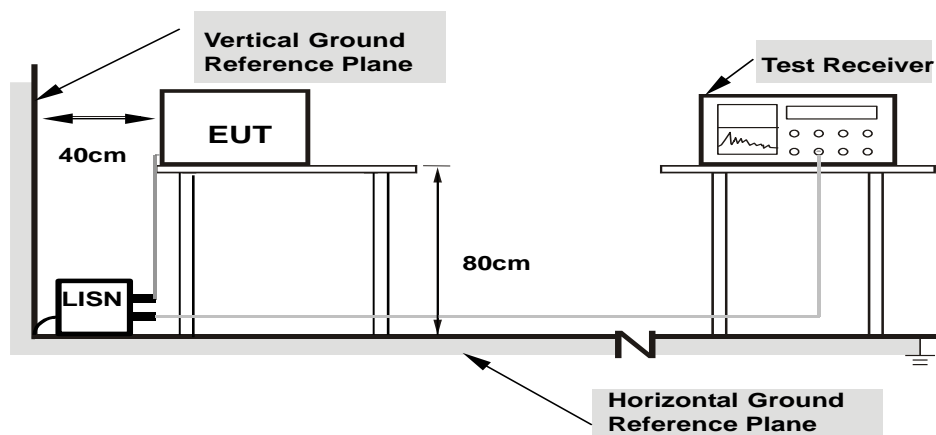

- Note:**
1. Support units were connected to second LISN.
 2. Both of LISNs (AMN) are 80 cm from EUT and at least 80 cm from other units and other metal planes

For the actual test configuration, please refer to the related item – Photographs of the Test Configuration.

4.1.6 EUT OPERATING CONDITIONS

Test Mode 1

- a. Placed the EUT and Bluetooth earphone on a testing table.
- b. The EUT link with Bluetooth earphone in idle mode.
- c. The EUT sent audio signal to the earphone.
- d. The EUT played MPEG4.
- e. The EUT communicated data with the wireless AP and CMU 200 upgrade function, which acted as communication partners.
- f. The communication partner connected with EUT via CDMA850, WLAN and NFC Rx function and run a test program (provided by manufacturer) to enable EUT under receiving condition continuously at specific channel frequency.
- g. The necessary accessories enable the system in full functions.

Test Mode 4

- a. Placed the EUT and Bluetooth earphone on a testing table.
- b. The EUT link with Bluetooth earphone in idle mode.
- c. The EUT sent audio signal to the earphone.
- d. The EUT communicated data with notebook.
- e. The notebook sent "H pattern" to the monitor, and the monitor displayed them.
- f. The EUT communicated data with the wireless AP, GPS Simulator and Radio Communication Analyzer, which acted as communication partners.
- g. The communication partner connected with EUT via LTE Band 2, WLAN and NFC Rx function and run a test program (provided by manufacturer) to enable EUT under receiving condition continuously at specific channel frequency.
- h. The necessary accessories enable the system in full functions.

4.1.7 TEST RESULTS

INPUT POWER	120 Vac, 60 Hz	6dB BANDWIDTH	9 kHz
ENVIRONMENTAL CONDITIONS	23deg. C, 53% RH	PHASE	Line 1
TEST MODE	1	TESTED BY	Skys Huang

No	Freq. [MHz]	Corr. Factor (dB)	Reading Value [dB (uV)]		Emission Level [dB (uV)]		Limit [dB (uV)]		Margin (dB)	
			Q.P.	AV.	Q.P.	AV.	Q.P.	AV.	Q.P.	AV.
			1	0.23984	0.18	40.58	24.11	40.76	24.29	62.10
2	0.68125	0.21	40.34	24.70	40.55	24.91	56.00	46.00	-15.45	-21.09
3	2.78516	0.34	39.03	26.01	39.37	26.35	56.00	46.00	-16.63	-19.65
4	3.05469	0.35	40.58	29.14	40.93	29.49	56.00	46.00	-15.07	-16.51
5	4.04688	0.39	44.45	34.17	44.84	34.56	56.00	46.00	-11.16	-11.44
6	9.77344	0.48	38.37	29.20	38.85	29.68	60.00	50.00	-21.15	-20.32

REMARKS:

1. Q.P. and AV. are abbreviations of quasi-peak and average individually.
2. The emission levels of other frequencies were very low against the limit.
3. Margin value = Emission level - Limit value
4. Correction factor = Insertion loss + Cable loss
5. Emission Level = Correction Factor + Reading Value.

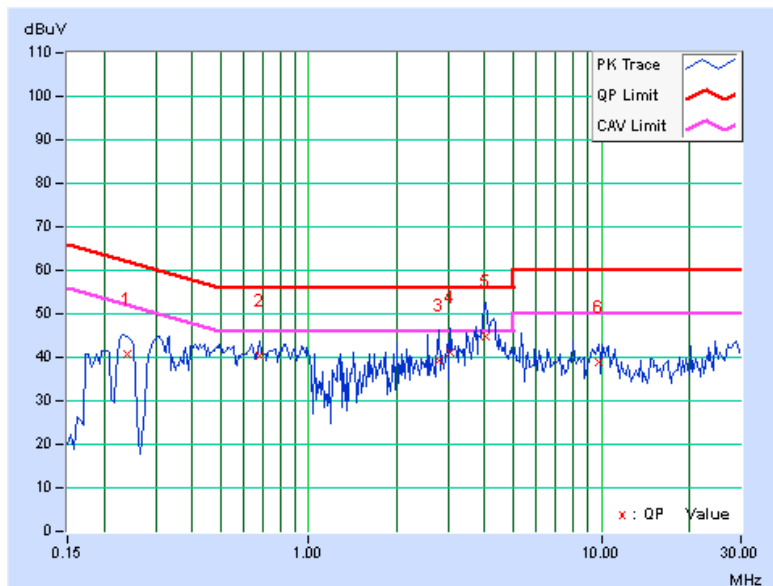

INPUT POWER	120 Vac, 60 Hz	6dB BANDWIDTH	9 kHz
ENVIRONMENTAL CONDITIONS	23deg. C, 53% RH	PHASE	Line 2
TEST MODE	1	TESTED BY	Skys Huang

No	Freq. [MHz]	Corr. Factor (dB)	Reading Value [dB (uV)]		Emission Level [dB (uV)]		Limit [dB (uV)]		Margin (dB)	
			Q.P.	AV.	Q.P.	AV.	Q.P.	AV.	Q.P.	AV.
			1	0.27500	0.16	38.15	27.78	38.31	27.94	60.97
2	0.47031	0.18	39.48	23.19	39.66	23.37	56.51	46.51	-16.85	-23.14
3	0.88438	0.19	35.84	20.61	36.03	20.80	56.00	46.00	-19.97	-25.20
4	1.76563	0.25	38.31	22.51	38.56	22.76	56.00	46.00	-17.44	-23.24
5	3.36328	0.34	41.59	29.47	41.93	29.81	56.00	46.00	-14.07	-16.19
6	4.01953	0.38	42.92	33.00	43.30	33.38	56.00	46.00	-12.70	-12.62
7	28.75391	0.69	37.36	22.58	38.05	23.27	60.00	50.00	-21.95	-26.73

REMARKS:

1. Q.P. and AV. are abbreviations of quasi-peak and average individually.
2. The emission levels of other frequencies were very low against the limit.
3. Margin value = Emission level - Limit value
4. Correction factor = Insertion loss + Cable loss
5. Emission Level = Correction Factor + Reading Value.

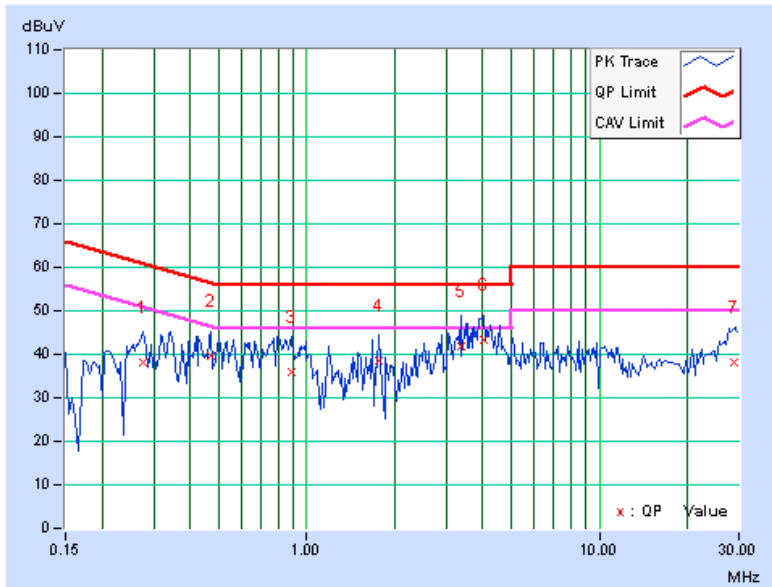

INPUT POWER	120 Vac, 60 Hz	6dB BANDWIDTH	9 kHz
ENVIRONMENTAL CONDITIONS	22deg. C, 60% RH	PHASE	Line 1
TEST MODE	4	TESTED BY	Daniel Lin

No	Freq.	Corr. Factor	Reading Value		Emission Level		Limit		Margin	
	[MHz]		[dB (uV)]		[dB (uV)]		[dB (uV)]		(dB)	
			Q.P.	AV.	Q.P.	AV.	Q.P.	AV.	Q.P.	AV.
1	0.22812	0.15	43.69	27.00	43.84	27.15	62.52	52.52	-18.68	-25.37
2	0.28672	0.16	43.58	32.38	43.74	32.54	60.62	50.62	-16.88	-18.08
3	0.47813	0.17	39.97	31.80	40.14	31.97	56.37	46.37	-16.23	-14.40
4	0.56016	0.18	37.53	25.42	37.71	25.60	56.00	46.00	-18.29	-20.40
5	2.57422	0.28	36.95	31.83	37.23	32.11	56.00	46.00	-18.77	-13.89
6	4.67578	0.35	36.54	31.54	36.89	31.89	56.00	46.00	-19.11	-14.11

REMARKS:

1. Q.P. and AV. are abbreviations of quasi-peak and average individually.
2. The emission levels of other frequencies were very low against the limit.
3. Margin value = Emission level - Limit value
4. Correction factor = Insertion loss + Cable loss
5. Emission Level = Correction Factor + Reading Value.

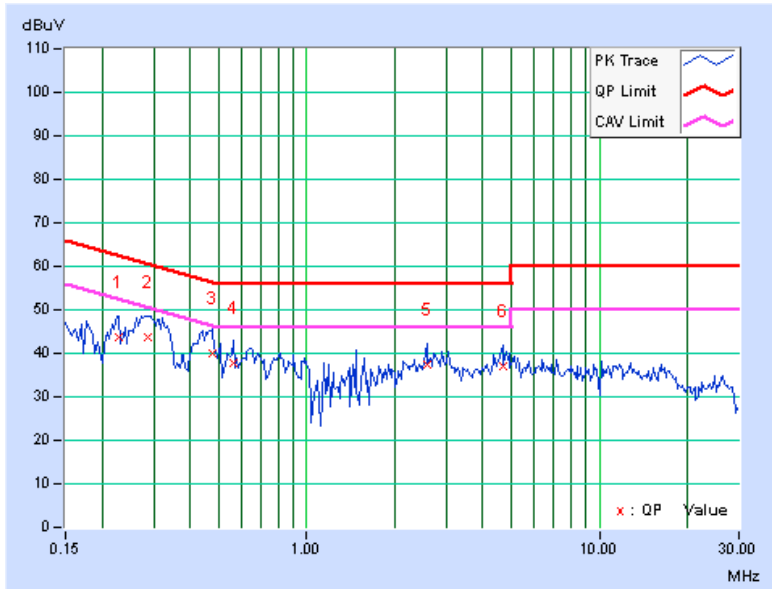

INPUT POWER	120 Vac, 60 Hz	6dB BANDWIDTH	9 kHz
ENVIRONMENTAL CONDITIONS	22deg. C, 60% RH	PHASE	Line 2
TEST MODE	4	TESTED BY	Daniel Lin

No	Freq.	Corr. Factor	Reading Value		Emission Level		Limit		Margin	
	[MHz]		[dB (uV)]	[dB (uV)]	[dB (uV)]	[dB (uV)]	[dB (uV)]	[dB (uV)]	[dB (uV)]	[dB (uV)]
			Q.P.	AV.	Q.P.	AV.	Q.P.	AV.	Q.P.	AV.
1	0.29063	0.15	45.35	38.36	45.50	38.51	60.51	50.51	-15.01	-12.00
2	0.31542	0.15	44.26	35.26	44.41	35.41	59.83	49.83	-15.41	-14.41
3	0.42850	0.16	41.96	31.10	42.12	31.26	57.28	47.28	-15.16	-16.02
4	0.48203	0.16	41.40	30.63	41.56	30.79	56.30	46.30	-14.74	-15.51
5	0.63828	0.17	38.84	30.58	39.01	30.75	56.00	46.00	-16.99	-15.25
6	2.80469	0.30	36.95	32.03	37.25	32.33	56.00	46.00	-18.75	-13.67

REMARKS:

1. Q.P. and AV. are abbreviations of quasi-peak and average individually.
2. The emission levels of other frequencies were very low against the limit.
3. Margin value = Emission level - Limit value
4. Correction factor = Insertion loss + Cable loss
5. Emission Level = Correction Factor + Reading Value.

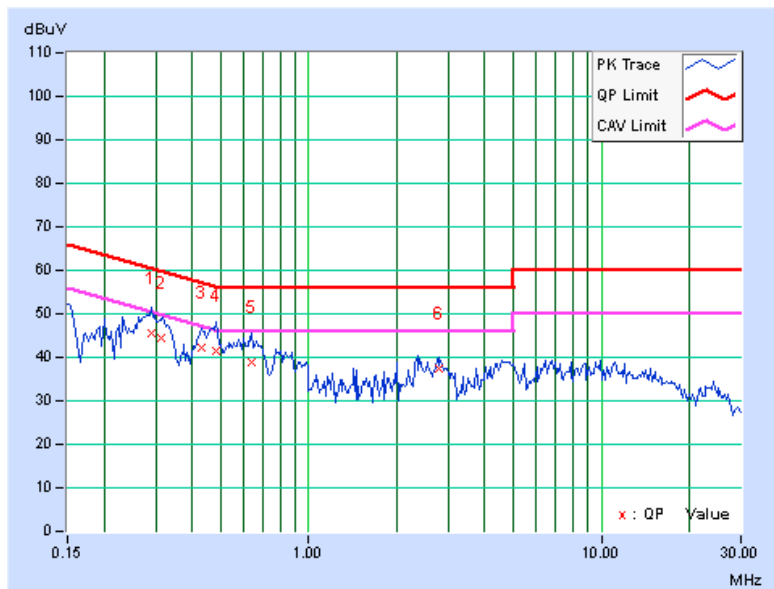

4.2 RADIATED EMISSION MEASUREMENT

4.2.1 LIMITS OF RADIATED EMISSION MEASUREMENT

TEST STANDARD:

FCC Part 15, Subpart B (section: 15.109)

ICES-003:2012 Issue 5 (section: 6.2)

Emissions radiated outside of the specified bands, shall be according to the general radiated limits as following:

Radiated Emissions Limits at 10 meters (dB μ V/m)				
Frequencies (MHz)	FCC 15B/ ICES-003, Class A	FCC 15B / ICES-003, Class B	CISPR 22, Class A	CISPR 22, Class B
30-88	39	29.5	40	30
88-216	43.5	33.1		
216-230	46.4	35.6		
230-960			47	37
960-1000	49.5	43.5	Not defined	Not defined
1000-3000	Avg: 49.5	Avg: 43.5		
3000+	Peak: 69.5	Peak: 63.5	Not defined	Not defined

Radiated Emissions Limits at 3 meters (dB μ V/m)				
Frequencies (MHz)	FCC 15B / ICES-003, Class A	FCC 15B / ICES-003, Class B	CISPR 22, Class A	CISPR 22, Class B
30-88	49.5	40	50.5	40.5
88-216	54	43.5		
216-230	56.9	46		
230-960			57.5	47.5
960-1000	60	54	Avg: 56 Peak: 76	Avg: 50 Peak: 70
1000-3000	Avg: 60	Avg: 54		
3000+	Peak: 80	Peak: 74	Avg: 60 Peak: 80	Avg: 54 Peak: 74

- NOTE:**
1. The lower limit shall apply at the transition frequencies.
 2. Emission level (dB μ V/m) = 20 log Emission level (μ V/m).
 3. As shown in 15.35(b), for frequencies above 1000MHz, the field strength limits are based on average detector, however, the peak field strength of any emission shall not exceed the maximum permitted average limits, specified above by more than 20dB under any condition of modulation.
 4. QP detector shall be applied if not specified.

4.2.2 TEST INSTRUMENTS

Frequency range 30MHz~1GHz

DESCRIPTION & MANUFACTURER	MODEL NO.	SERIAL NO.	DATE OF CALIBRATION	DUE DATE OF CALIBRATION
Test Receiver ROHDE & SCHWARZ (V)	ESIB7	100187	Jan. 30, 2012	Jan. 29, 2013
Test Receiver ROHDE & SCHWARZ (H)	ESIB7	100186	Nov. 29, 2011	Nov. 28, 2012
Spectrum Analyzer Agilent	E4446A	MY48250266	Aug. 29, 2012	Aug. 28, 2013
BILOG Antenna SCHWARZBECK (V)	VULB9168	9168-148	Apr. 02, 2012	Apr. 01, 2013
BILOG Antenna SCHWARZBECK (H)	VULB9168	9168-149	Apr. 06, 2012	Apr. 05, 2013
Preamplifier Agilent (V)	8447D	2944A10636	Oct. 29, 2011	Oct. 28, 2012
Preamplifier Agilent (H)	8447D	2944A10637	Oct. 29, 2011	Oct. 28, 2012
Preamplifier Agilent	8449B	3008A01959	Oct. 29, 2011	Oct. 28, 2012
RF signal cable Woken (V)	8D-FB	Cable-Hych1-01	Oct. 29, 2011	Oct. 28, 2012
RF signal cable Woken (H)	8D-FB	Cable-Hych1-02	Oct. 29, 2011	Oct. 28, 2012
Software ADT	BV ADT_Radiated_ V 7.7.03.7	NA	NA	NA
Antenna Tower (V)	MFA-440	9707	NA	NA
Antenna Tower (H)	MFA-440	970705	NA	NA
Turn Table	DS430	50303	NA	NA
Controller (V)	MF7802	074	NA	NA
Controller (H)	MF7802	08093	NA	NA
Fix tool for Boresight antenna tower	BAF-01	1	NA	NA
RF signal cable EAST COST Microwave	HP 160S-29	NA	Oct. 29, 2011	Oct. 28, 2012

- NOTE:**
1. The calibration interval of the above test instruments is 12 months and the calibrations are traceable to NML/ROC and NIST/USA.
 2. The test was performed in HwaYa Chamber 1.
 3. The FCC Site Registration No. is 477732.
 4. The IC Site Registration No. is IC 7450F-1.
 5. The VCCI Site Registration No. is R-1893.

Frequency range above 1GHz

DESCRIPTION & MANUFACTURER	MODEL NO.	SERIAL NO.	DATE OF CALIBRATION	DUE DATE OF CALIBRATION
Test Receiver ROHDE & SCHWARZ	ESIB7	100188	May 11, 2012	May 10, 2013
Spectrum Analyzer Agilent	E4446A	MY48250266	Aug. 29, 2012	Aug. 28, 2013
BILOG Antenna SCHWARZBECK	VULB9168	9168-157	Apr. 02, 2012	Apr. 01, 2013
RF signal cable Woken	8D-FB	N/A	Mar. 24, 2012	Mar. 23, 2013
HORN Antenna SCHWARZBECK	BBHA 9120 D	9120D-405	Feb. 03, 2012	Feb. 02, 2013
HORN Antenna SCHWARZBECK	BBHA 9170	BBHA9170243	Jan. 03, 2012	Jan. 02, 2013
Preamplifier Agilent (Below 1GHz)	8447D	2944A10629	Oct. 29, 2011	Oct. 28, 2012
Preamplifier Agilent (Above 1GHz)	8449B	3008A01959	Oct. 29, 2011	Oct. 28, 2012
RF signal cable HUBER+SUHNER	SUCOFLEX 104	230132/4	Nov. 03, 2011	Nov. 02, 2012
RF signal cable HUBER+SUHNER	SUCOFLEX 104	309223/4+309 218/4	Nov. 03, 2011	Nov. 02, 2012
Software ADT	BV ADT_Radiated_ V7.6.15.9.3	NA	NA	NA
Antenna Tower ADT	AT100	AT93021702	NA	NA
Turn Table ADT	TT100	TT93021702	NA	NA
Controller ADT	SC100	SC93021702	NA	NA
Fix tool for Boresight antenna tower	BAF-01	2	NA	NA

- NOTE:**
1. The calibration interval of the above test instruments is 12 months and the calibrations are traceable to NML/ROC and NIST/USA.
 2. The test was performed in HwaYa Chamber 2.
 3. The horn antenna and HP preamplifier (model: 8449B) are used only for the measurement of emission frequency above 1GHz if tested.
 4. The FCC Site Registration No. is 686814.
 5. The IC Site Registration No. is IC 7450F-2.
 6. The VCCI Site Registration No. is G-18.

4.2.3 TEST PROCEDURES

Frequency range 30MHz~1GHz

- a. The EUT was placed on the top of a rotating table 0.8 meters above the ground at a 10 meter semi-anechoic chamber room. The table was rotated 360 degrees to determine the position of the highest radiation.
- b. The EUT was set 10 meters away from the interference-receiving antenna, which was mounted on the top of a variable-height antenna tower.
- c. The height of antenna is varied from 1 meter to 4 meters above the ground to determine the maximum value of the field strength. Both horizontal and vertical polarizations of the antenna are set to make the measurement.
- d. For each suspected emission, the EUT was arranged to its worst case and then the antenna was tuned to heights from 1 meter to 4 meters and the rotatable table was turned from 0 degrees to 360 degrees to find the maximum reading.
- e. The test-receiver system was set to quasi-peak detect function and specified bandwidth with maximum hold mode when the test frequency is below 1GHz.

NOTE: The resolution bandwidth of test receiver/spectrum analyzer is 120kHz for Quasi-Peak (QP) detection at frequency below 1GHz.

Frequency range above 1GHz

- a. The EUT was placed on the top of a rotating table 0.8 meters above the ground at a 3 meter semi-anechoic chamber room. The table was rotated 360 degrees to determine the position of the highest radiation.
- b. The EUT was set 3 meters away from the interference-receiving antenna, which was mounted on the top of a variable-height antenna tower.
- c. The height of antenna can be varied from 1 meter to 4 meters, the height of adjustment depends on the EUT height and the antenna 3dB beamwidth both, to detect the maximum value of the field strength. Both horizontal and vertical polarizations of the antenna are set to make the measurement.
- d. For each suspected emission, the EUT was arranged to its worst case and then the antenna was tuned to heights and the rotatable table was turned from 0 degrees to 360 degrees to find the maximum reading.
- e. The test-receiver system was set to peak and average detect function and specified bandwidth with maximum hold mode when the test frequency is above 1GHz.

NOTE:

1. The resolution bandwidth is 1MHz and video bandwidth of test receiver/spectrum analyzer is 3MHz for Peak (PK) detection at frequency above 1GHz. The resolution bandwidth of test receiver/spectrum analyzer is 1MHz for Average (AV) detection at frequency above 1GHz.
2. For measurement of frequency above 1000MHz, the EUT was set 3 meters away from the receiver antenna.

4.2.4 DEVIATION FROM TEST STANDARD

No deviation.

4.2.5 TEST SETUP

Frequency range 30MHz~1GHz

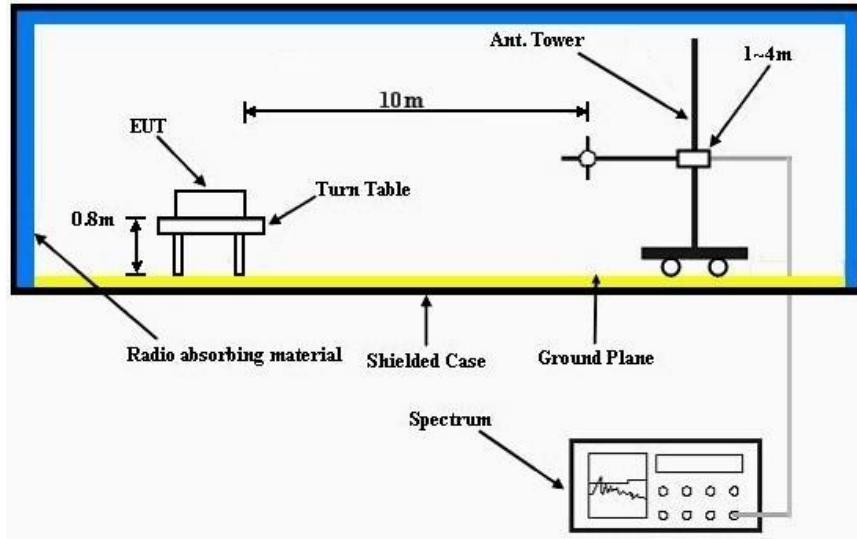

Frequency range above 1GHz

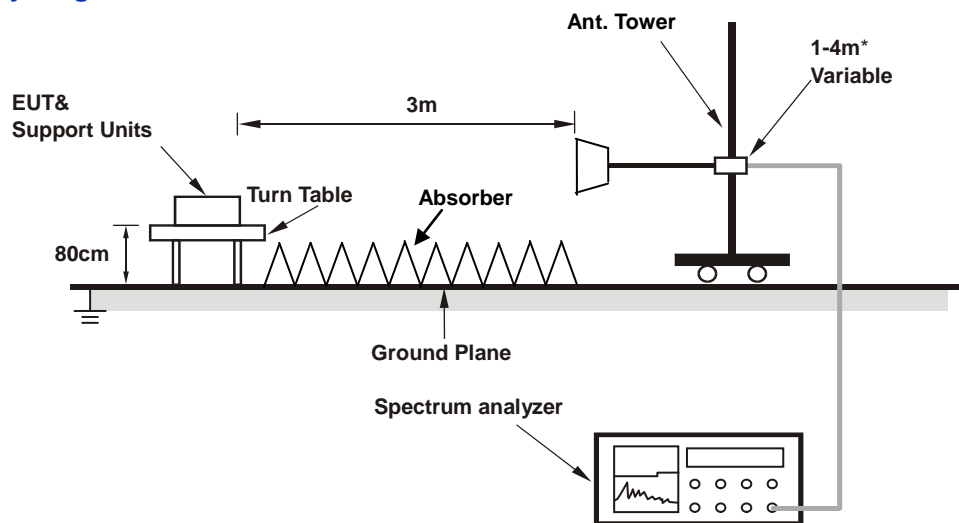

* : depends on the EUT height and the antenna 3dB beamwidth both, refer to section 8.3.1.2 of ANSI C63.4:2009.

For the actual test configuration, please refer to the related Item – Photographs of the Test Configuration.

4.2.6 EUT OPERATING CONDITIONS

Same as item 4.1.6.

4.2.7 TEST RESULTS

INPUT POWER	120 Vac, 60 Hz	FREQUENCY RANGE	30-1000 MHz
ENVIRONMENTAL CONDITIONS	23 deg. C, 69% RH	DETECTOR FUNCTION & BANDWIDTH	Quasi-Peak , 120 kHz
TEST MODE	1	TESTED BY	Daniel Lin

ANTENNA POLARITY & TEST DISTANCE: HORIZONTAL AT 10 M								
No.	Freq. (MHz)	Emission Level (dBuV/m)	Limit (dBuV/m)	Margin (dB)	Antenna Height (m)	Table Angle (Degree)	Raw Value (dBuV)	Correction Factor (dB/m)
1	34.25	14.77 QP	30.00	-15.23	3.50 H	332	2.15	12.62
2	91.24	13.52 QP	30.00	-16.48	3.50 H	271	4.86	8.66
3	157.24	16.38 QP	30.00	-13.62	1.50 H	327	1.77	14.61
4	196.75	15.28 QP	30.00	-14.72	1.00 H	157	3.41	11.87
5	503.76	21.93 QP	37.00	-15.07	1.50 H	24	0.68	21.25
6	672.55	22.85 QP	37.00	-14.15	4.00 H	335	-1.72	24.57

- REMARKS:**
1. Emission level(dBuV/m)=Raw Value(dBuV) + Correction Factor(dB/m)
 2. Correction Factor(dB/m) = Antenna Factor (dB/m) + Cable Factor (dB)
 3. The other emission levels were very low against the limit.
 4. Margin value = Emission level – Limit value.

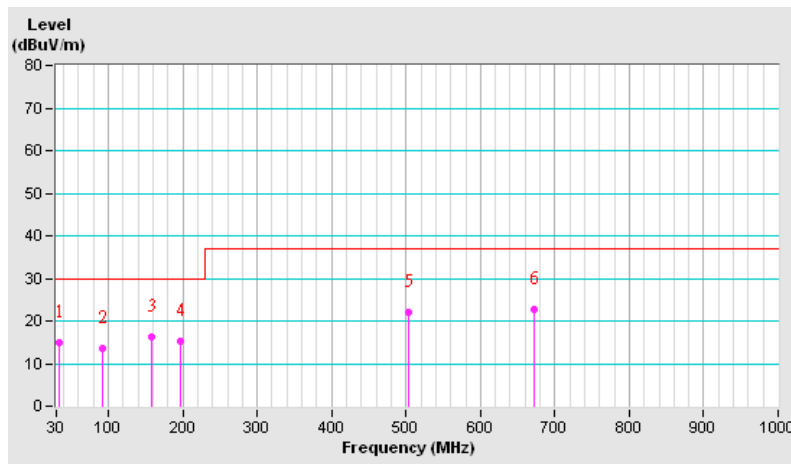

INPUT POWER	120 Vac, 60 Hz	FREQUENCY RANGE	30-1000 MHz
ENVIRONMENTAL CONDITIONS	23 deg. C, 69% RH	DETECTOR FUNCTION & BANDWIDTH	Quasi-Peak , 120 kHz
TEST MODE	1	TESTED BY	Daniel Lin

ANTENNA POLARITY & TEST DISTANCE: VERTICAL AT 10 M								
No.	Freq. (MHz)	Emission Level (dBuV/m)	Limit (dBuV/m)	Margin (dB)	Antenna Height (m)	Table Angle (Degree)	Raw Value (dBuV)	Correction Factor (dB/m)
1	30.15	26.64 QP	30.00	-3.36	1.00 V	334	14.29	12.35
2	50.24	18.24 QP	30.00	-11.76	1.00 V	174	4.25	13.99
3	132.46	17.43 QP	30.00	-12.57	2.50 V	10	4.02	13.41
4	188.24	18.94 QP	30.00	-11.06	1.50 V	12	6.31	12.63
5	662.27	23.59 QP	37.00	-13.41	3.50 V	182	-0.91	24.50
6	761.22	26.17 QP	37.00	-10.83	2.00 V	34	-0.12	26.29

- REMARKS:**
1. Emission level(dBuV/m)=Raw Value(dBuV) + Correction Factor(dB/m)
 2. Correction Factor(dB/m) = Antenna Factor (dB/m) + Cable Factor (dB)
 3. The other emission levels were very low against the limit.
 4. Margin value = Emission level – Limit value.

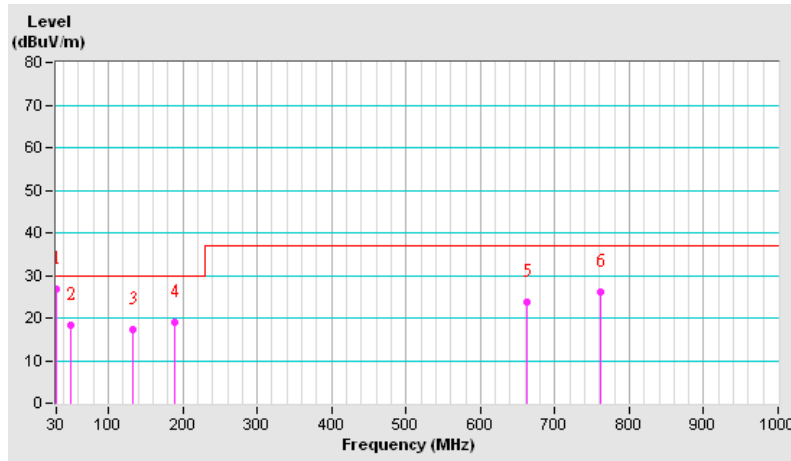

INPUT POWER	120 Vac, 60 Hz	FREQUENCY RANGE	1-40 GHz
ENVIRONMENTAL CONDITIONS	22 deg. C, 60% RH	DETECTOR FUNCTION & BANDWIDTH	Peak/Average, 1 MHz
TEST MODE	1	TESTED BY	Daniel Lin

ANTENNA POLARITY & TEST DISTANCE: HORIZONTAL AT 3 M								
No.	Freq. (MHz)	Emission Level (dBuV/m)	Limit (dBuV/m)	Margin (dB)	Antenna Height (m)	Table Angle (Degree)	Raw Value (dBuV)	Correction Factor (dB/m)
1	1024.20	35.91 PK	74.00	-38.09	1.00 H	125	8.03	27.88
2	1024.20	29.61 AV	54.00	-24.39	1.00 H	125	1.73	27.88
3	1542.20	40.06 PK	74.00	-33.94	1.14 H	125	10.52	29.54
4	1542.20	34.06 AV	54.00	-19.94	1.14 H	125	4.52	29.54
5	1852.20	40.14 PK	74.00	-33.86	1.00 H	125	9.85	30.29
6	1852.20	34.74 AV	54.00	-19.26	1.00 H	125	4.45	30.29

- REMARKS:**
1. Emission level(dBuV/m)=Raw Value(dBuV) + Correction Factor(dB/m)
 2. Correction Factor(dB/m) = Antenna Factor (dB/m) + Cable Factor (dB)
 3. The other emission levels were very low against the limit.
 4. Margin value = Emission level – Limit value.

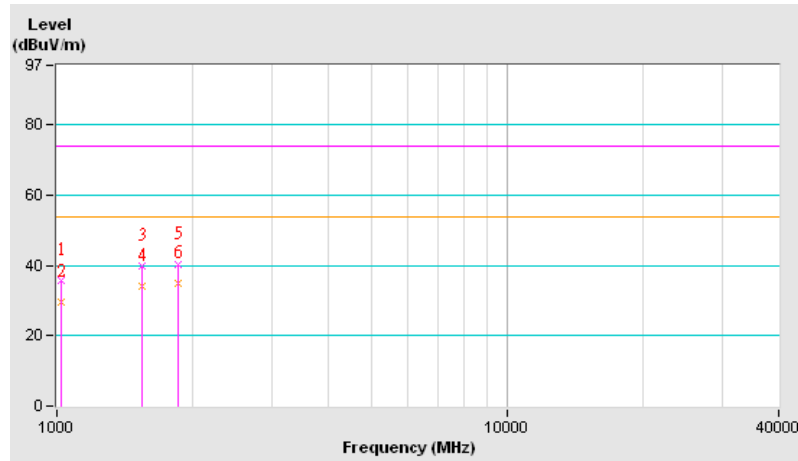

INPUT POWER	120 Vac, 60 Hz	FREQUENCY RANGE	1-40 GHz
ENVIRONMENTAL CONDITIONS	22 deg. C, 60% RH	DETECTOR FUNCTION & BANDWIDTH	Peak/Average, 1 MHz
TEST MODE	1	TESTED BY	Daniel Lin

ANTENNA POLARITY & TEST DISTANCE: VERTICAL AT 3 M								
No.	Freq. (MHz)	Emission Level (dBuV/m)	Limit (dBuV/m)	Margin (dB)	Antenna Height (m)	Table Angle (Degree)	Raw Value (dBuV)	Correction Factor (dB/m)
1	1031.22	46.12 PK	74.00	-27.88	1.00 V	128	18.21	27.91
2	1031.22	36.20 AV	54.00	-17.80	1.00 V	128	8.29	27.91
3	1510.20	44.10 PK	74.00	-29.90	1.12 V	125	14.64	29.46
4	1510.20	36.70 AV	54.00	-17.30	1.12 V	125	7.24	29.46
5	1832.30	44.20 PK	74.00	-29.80	1.00 V	125	13.96	30.24
6	1832.30	33.90 AV	54.00	-20.10	1.00 V	125	3.66	30.24

- REMARKS:**
1. Emission level(dBuV/m)=Raw Value(dBuV) + Correction Factor(dB/m)
 2. Correction Factor(dB/m) = Antenna Factor (dB/m) + Cable Factor (dB)
 3. The other emission levels were very low against the limit.
 4. Margin value = Emission level – Limit value.

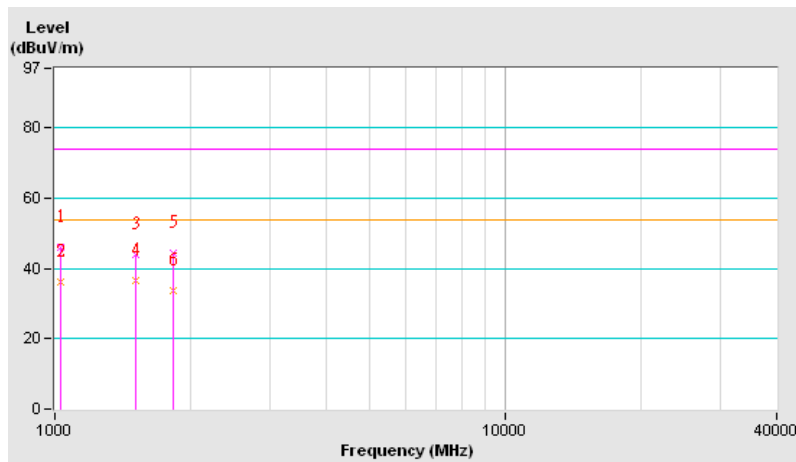

INPUT POWER	120 Vac, 60 Hz	FREQUENCY RANGE	30-1000 MHz
ENVIRONMENTAL CONDITIONS	23 deg. C, 69% RH	DETECTOR FUNCTION & BANDWIDTH	Quasi-Peak , 120 kHz
TEST MODE	4	TESTED BY	Rolan Zheng

ANTENNA POLARITY & TEST DISTANCE: HORIZONTAL AT 10 M								
No.	Freq. (MHz)	Emission Level (dBuV/m)	Limit (dBuV/m)	Margin (dB)	Antenna Height (m)	Table Angle (Degree)	Raw Value (dBuV)	Correction Factor (dB/m)
1	76.65	20.87 QP	30.00	-9.13	2.50 H	104	9.99	10.88
2	125.25	24.69 QP	30.00	-5.31	2.50 H	70	12.05	12.64
3	171.90	21.57 QP	30.00	-8.43	4.00 H	156	7.69	13.88
4	243.83	26.24 QP	37.00	-10.76	4.00 H	17	12.71	13.53
5	267.15	30.36 QP	37.00	-6.64	3.50 H	74	15.86	14.50
6	480.01	33.87 QP	37.00	-3.13	2.27 H	91	13.17	20.70
7	720.08	28.01 QP	37.00	-8.99	4.00 H	150	2.67	25.34

- REMARKS:**
1. Emission level(dBuV/m)=Raw Value(dBuV) + Correction Factor(dB/m)
 2. Correction Factor(dB/m) = Antenna Factor (dB/m) + Cable Factor (dB)
 3. The other emission levels were very low against the limit.
 4. Margin value = Emission level – Limit value.

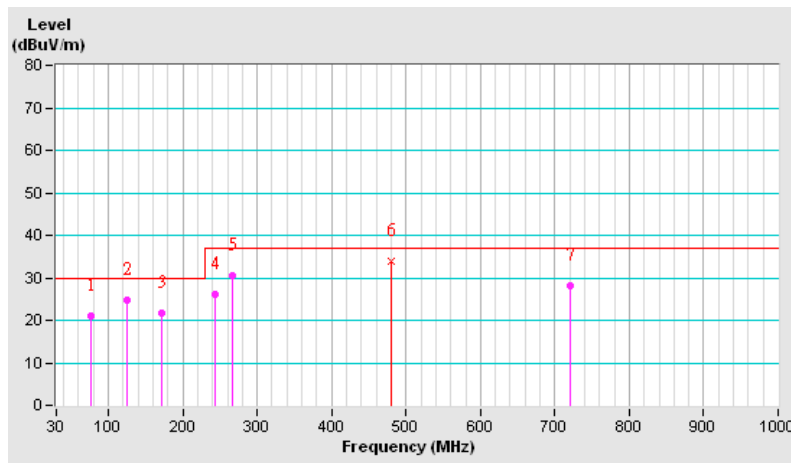

INPUT POWER	120 Vac, 60 Hz	FREQUENCY RANGE	30-1000 MHz
ENVIRONMENTAL CONDITIONS	23 deg. C, 69% RH	DETECTOR FUNCTION & BANDWIDTH	Quasi-Peak , 120 kHz
TEST MODE	4	TESTED BY	Rolan Zheng

ANTENNA POLARITY & TEST DISTANCE: VERTICAL AT 10 M								
No.	Freq. (MHz)	Emission Level (dBuV/m)	Limit (dBuV/m)	Margin (dB)	Antenna Height (m)	Table Angle (Degree)	Raw Value (dBuV)	Correction Factor (dB/m)
1	61.10	22.18 QP	30.00	-7.82	2.00 V	272	8.68	13.50
2	117.47	26.48 QP	30.00	-3.52	1.00 V	343	14.65	11.83
3	168.02	24.97 QP	30.00	-5.03	1.00 V	0	10.76	14.21
4	239.94	27.39 QP	37.00	-9.61	3.00 V	179	14.02	13.37
5	479.04	28.28 QP	37.00	-8.72	1.00 V	46	7.58	20.70
6	774.51	31.40 QP	37.00	-5.60	3.00 V	360	4.86	26.54

- REMARKS:**
1. Emission level(dBuV/m)=Raw Value(dBuV) + Correction Factor(dB/m)
 2. Correction Factor(dB/m) = Antenna Factor (dB/m) + Cable Factor (dB)
 3. The other emission levels were very low against the limit.
 4. Margin value = Emission level – Limit value.

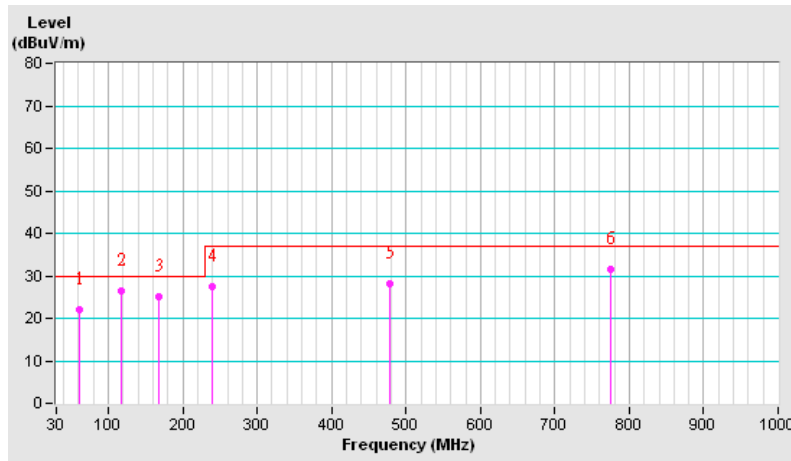

INPUT POWER	120 Vac, 60 Hz	FREQUENCY RANGE	1-40 GHz
ENVIRONMENTAL CONDITIONS	22 deg. C, 60% RH	DETECTOR FUNCTION & BANDWIDTH	Peak/Average, 1 MHz
TEST MODE	4	TESTED BY	Felix Chen

ANTENNA POLARITY & TEST DISTANCE: HORIZONTAL AT 3 M								
No.	Freq. (MHz)	Emission Level (dBuV/m)	Limit (dBuV/m)	Margin (dB)	Antenna Height (m)	Table Angle (Degree)	Raw Value (dBuV)	Correction Factor (dB/m)
1	1002.03	51.47 PK	74.00	-22.53	1.00 H	26	23.66	27.81
2	1002.03	35.94 AV	54.00	-18.06	1.00 H	26	8.13	27.81
3	1660.96	41.67 PK	74.00	-32.33	1.50 H	106	11.84	29.83
4	1660.96	31.33 AV	54.00	-22.67	1.50 H	106	1.50	29.83
5	2983.96	47.15 PK	74.00	-26.85	1.22 H	232	13.04	34.11
6	2983.96	37.73 AV	54.00	-16.27	1.22 H	232	3.62	34.11

- REMARKS:**
1. Emission level(dBuV/m)=Raw Value(dBuV) + Correction Factor(dB/m)
 2. Correction Factor(dB/m) = Antenna Factor (dB/m) + Cable Factor (dB)
 3. The other emission levels were very low against the limit.
 4. Margin value = Emission level – Limit value.

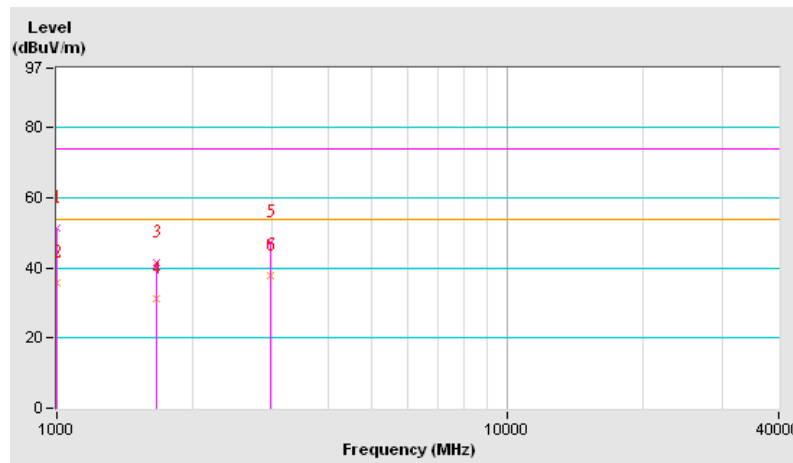

INPUT POWER	120 Vac, 60 Hz	FREQUENCY RANGE	1-40 GHz
ENVIRONMENTAL CONDITIONS	22 deg. C, 60% RH	DETECTOR FUNCTION & BANDWIDTH	Peak/Average, 1 MHz
TEST MODE	4	TESTED BY	Felix Chen

ANTENNA POLARITY & TEST DISTANCE: VERTICAL AT 3 M								
No.	Freq. (MHz)	Emission Level (dBuV/m)	Limit (dBuV/m)	Margin (dB)	Antenna Height (m)	Table Angle (Degree)	Raw Value (dBuV)	Correction Factor (dB/m)
1	1001.23	48.04 PK	74.00	-25.96	1.00 V	126	20.24	27.80
2	1001.23	33.09 AV	54.00	-20.91	1.00 V	126	5.29	27.80
3	1661.32	47.99 PK	74.00	-26.01	1.24 V	265	18.16	29.83
4	1661.32	31.87 AV	54.00	-22.13	1.24 V	265	2.04	29.83
5	2999.57	48.46 PK	74.00	-25.54	1.02 V	336	14.31	34.15
6	2999.57	39.05 AV	54.00	-14.95	1.02 V	336	4.90	34.15

- REMARKS:**
1. Emission level(dBuV/m)=Raw Value(dBuV) + Correction Factor(dB/m)
 2. Correction Factor(dB/m) = Antenna Factor (dB/m) + Cable Factor (dB)
 3. The other emission levels were very low against the limit.
 4. Margin value = Emission level – Limit value.

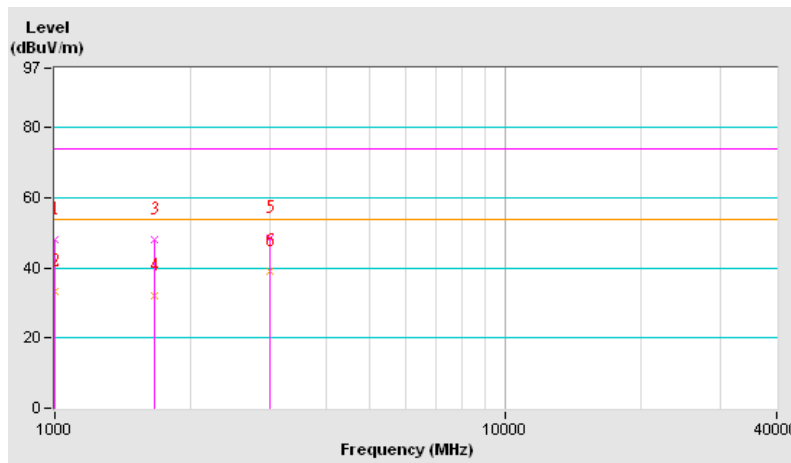



5 PHOTOGRAPHS OF THE TEST CONFIGURATION

Please refer to the attached file (Test Setup Photo).



A D T

6 INFORMATION ON THE TESTING LABORATORIES

We, Bureau Veritas Consumer Products Services (H.K.) Ltd., Taoyuan Branch, were founded in 1988 to provide our best service in EMC, Radio, Telecom and Safety consultation. Our laboratories are accredited and approved according to ISO/IEC 17025.

If you have any comments, please feel free to contact us at the following:

Linko EMC/RF Lab

Tel: 886-2-26052180

Fax: 886-2-26051924

Hsin Chu EMC/RF Lab

Tel: 886-3-5935343

Fax: 886-3-5935342

Hwa Ya EMC/RF/Safety/Telecom Lab

Tel: 886-3-3183232

Fax: 886-3-3270892

Email: service.adt@tw.bureauveritas.com

Web Site: www.adt.com.tw

The address and road map of all our labs can be found in our web site also.

7 APPENDIX A – MODIFICATION RECORDERS FOR ENGINEERING CHANGES TO THE EUT BY THE LAB

No modifications were made to the EUT by the lab during the test.

--- END ---