



FCC TEST REPORT (15.247)

REPORT NO.: RF120822C31-4
MODEL NO.: XT901
FCC ID: IHDP56NA1
RECEIVED: Aug. 22, 2012
TESTED: Sep. 07 ~ Oct. 18, 2012
ISSUED: Oct. 23, 2012

APPLICANT: Motorola Mobility, Inc.

ADDRESS: No. 1, Wang Jing East Road, Chao Yang District,
Beijing, 100102, P. R. China

ISSUED BY: Bureau Veritas Consumer Products Services
(H.K.) Ltd., Taoyuan Branch

LAB ADDRESS: No. 47, 14th Ling, Chia Pau Vil., Lin Kou Dist.,
New Taipei City, Taiwan (R.O.C)

TEST LOCATION: No. 19, Hwa Ya 2nd Rd, Wen Hwa Tsuen, Kwei
Shan Hsiang, Taoyuan Hsien 333, Taiwan, R.O.C.

This report should not be used by the client to claim product certification, approval, or endorsement by TAF or any government agencies.



This report is for your exclusive use. Any copying or replication of this report to or for any other person or entity, or use of our name or trademark, is permitted only with our prior written permission. This report sets forth our findings solely with respect to the test samples identified herein. The results set forth in this report are not indicative or representative of the quality or characteristics of the lot from which a test sample was taken or any similar or identical product unless specifically and expressly noted. Our report includes all of the tests requested by you and the results thereof based upon the information that you provided to us. You have 60 days from date of issuance of this report to notify us of any material error or omission caused by our negligence, provided, however, that such notice shall be in writing and shall specifically address the issue you wish to raise. A failure to raise such issue within the prescribed time shall constitute your unqualified acceptance of the completeness of this report, the tests conducted and the correctness of the report contents. Unless specific mention, the uncertainty of measurement has been explicitly taken into account to declare the compliance or non-compliance to the specification.



TABLE OF CONTENTS

RELEASE CONTROL RECORD	4
1. CERTIFICATION.....	5
2. SUMMARY OF TEST RESULTS.....	6
2.1 MEASUREMENT UNCERTAINTY	6
3. GENERAL INFORMATION	7
3.1 GENERAL DESCRIPTION OF EUT.....	7
3.2 DESCRIPTION OF TEST MODES.....	8
3.2.1 TEST MODE APPLICABILITY AND TESTED CHANNEL DETAIL.....	9
3.3 DESCRIPTION OF SUPPORT UNITS.....	11
3.3.1 CONFIGURATION OF SYSTEM UNDER TEST	11
3.4 GENERAL DESCRIPTION OF APPLIED STANDARDS.....	11
4. TEST TYPES AND RESULTS.....	12
4.1 RADIATED EMISSION AND BANDEDGE MEASUREMENT	12
4.1.1 LIMITS OF RADIATED EMISSION AND BANDEDGE MEASUREMENT	12
4.1.2 TEST INSTRUMENTS	13
4.1.3 TEST PROCEDURES.....	14
4.1.4 DEVIATION FROM TEST STANDARD	14
4.1.5 TEST SETUP.....	15
4.1.6 EUT OPERATING CONDITIONS.....	15
4.1.7 TEST RESULTS	16
4.2 CONDUCTED EMISSION MEASUREMENT	42
4.2.1 LIMITS OF CONDUCTED EMISSION MEASUREMENT	42
4.2.2 TEST INSTRUMENTS	42
4.2.3 TEST PROCEDURES.....	43
4.2.4 DEVIATION FROM TEST STANDARD	43
4.2.5 TEST SETUP.....	44
4.2.6 EUT OPERATING CONDITIONS.....	44
4.2.7 TEST RESULTS	45
4.3 6DB BANDWIDTH MEASUREMENT.....	47
4.3.1 LIMITS OF 6DB BANDWIDTH MEASUREMENT.....	47
4.3.2 TEST SETUP.....	47
4.3.3 TEST INSTRUMENTS	47
4.3.4 TEST PROCEDURE	47
4.3.5 DEVIATION FROM TEST STANDARD	47
4.3.6 EUT OPERATING CONDITIONS.....	47
4.3.7 TEST RESULTS	48
4.4 CONDUCTED OUTPUT POWER.....	52
4.4.1 LIMITS OF CONDUCTED OUTPUT POWER MEASUREMENT	52
4.4.2 TEST SETUP.....	52
4.4.3 TEST INSTRUMENTS	52
4.4.4 TEST PROCEDURES.....	52
4.4.5 DEVIATION FROM TEST STANDARD	52
4.4.6 EUT OPERATING CONDITIONS.....	52
4.4.7 TEST RESULTS	53
4.5 POWER SPECTRAL DENSITY MEASUREMENT	55
4.5.1 LIMITS OF POWER SPECTRAL DENSITY MEASUREMENT	55
4.5.2 TEST SETUP.....	55
4.5.3 TEST INSTRUMENTS	55
4.5.4 TEST PROCEDURE	55



A D T

4.5.5	DEVIATION FROM TEST STANDARD	55
4.5.6	EUT OPERATING CONDITION	55
4.5.7	TEST RESULTS	56
4.6	CONDUCTED OUT OF BAND EMISSION MEASUREMENT	60
4.6.1	LIMITS OF CONDUCTED OUT OF BAND EMISSION MEASUREMENT	60
4.6.2	TEST SETUP	60
4.6.3	TEST INSTRUMENTS	60
4.6.4	TEST PROCEDURE	60
4.6.5	DEVIATION FROM TEST STANDARD	61
4.6.6	EUT OPERATING CONDITION	61
4.6.7	TEST RESULTS	61
5.	PHOTOGRAPHS OF THE TEST CONFIGURATION	70
6.	INFORMATION ON THE TESTING LABORATORIES	71
7.	APPENDIX A - MODIFICATIONS RECORDERS FOR ENGINEERING CHANGES TO THE EUT BY THE LAB	72



A D T

RELEASE CONTROL RECORD

ISSUE NO.	REASON FOR CHANGE	DATE ISSUED
RF120822C31-4	Original release	Oct. 23, 2012

1. CERTIFICATION

PRODUCT: Mobile Phone
MODEL NO.: XT901
BRAND: Motorola
APPLICANT: Motorola Mobility, Inc.
TESTED: Sep. 07 ~ Oct. 18, 2012
TEST SAMPLE: ENGINEERING SAMPLE
STANDARDS: FCC Part 15, Subpart C (Section 15.247)

The above equipment (model: XT901) has been tested by **Bureau Veritas Consumer Products Services (H.K.) Ltd., Taoyuan Branch**, and found compliance with the requirement of the above standards. The test record, data evaluation & Equipment Under Test (EUT) configurations represented herein are true and accurate accounts of the measurements of the sample's EMC characteristics under the conditions specified in this report.

PREPARED BY : Ivonne Wu , **DATE :** Oct. 23, 2012
Ivonne Wu / Senior Specialist

APPROVED BY : Ken Liu , **DATE :** Oct. 23, 2012
Ken Liu / Manager



A D T

2. SUMMARY OF TEST RESULTS

The EUT has been tested according to the following specifications:

APPLIED STANDARD: FCC PART 15, SUBPART C (SECTION 15.247)			
STANDARD SECTION	TEST TYPE	RESULT	REMARK
15.207	AC Power Conducted Emission	PASS	Meet the requirement of limit. Minimum passing margin is -12.64dB at 3.89844MHz.
15.247(d) 15.209	Radiated Emissions	PASS	Meet the requirement of limit. Minimum passing margin is -3.22dB at 2390.00MHz.
15.247(d)	Band Edge Measurement	PASS	Meet the requirement of limit.
15.247(a)(2)	6dB bandwidth	PASS	Meet the requirement of limit.
15.247(b)	Conducted power	PASS	Meet the requirement of limit.
15.247(e)	Power Spectral Density	PASS	Meet the requirement of limit.
15.203	Antenna Requirement	PASS	No antenna connector is used.

2.1 MEASUREMENT UNCERTAINTY

Where relevant, the following measurement uncertainty levels have been estimated for tests performed on the EUT as specified in CISPR 16-4-2:

MEASUREMENT	FREQUENCY	UNCERTAINTY
Conducted emissions	9kHz~30MHz	2.44 dB
Radiated emissions	30MHz ~ 200MHz	2.93 dB
	200MHz ~1000MHz	2.95 dB
	1GHz ~ 18GHz	2.26 dB
	18GHz ~ 40GHz	1.94 dB

This uncertainty represents an expanded uncertainty expressed at approximately the 95% confidence level using a coverage factor of $k = 2$.



3. GENERAL INFORMATION

3.1 GENERAL DESCRIPTION OF EUT

EUT	Mobile Phone
MODEL NO.	XT901
POWER SUPPLY	5.0Vdc (adapter or host equipment) 3.8Vdc (Li-ion battery)
MODULATION TYPE	CCK, DQPSK, DBPSK for DSSS 64QAM, 16QAM, QPSK, BPSK for OFDM
MODULATION TECHNOLOGY	DSSS, OFDM
TRANSFER RATE	802.11b:11.0/ 5.5/ 2.0/ 1.0Mbps 802.11g: 54.0/ 48.0/ 36.0/ 24.0/ 18.0/ 12.0/ 9.0/ 6.0Mbps 802.11n: up to 135.0Mbps
OPERATING FREQUENCY	2412 ~ 2462MHz
NUMBER OF CHANNEL	11 for 802.11b, 802.11g, 802.11n (20MHz) 7 for 802.11n (40MHz)
OUTPUT POWER	190.985mW
ANTENNA TYPE	PIFA antenna with -4dBi gain
ANTENNA CONNECTOR	NA
DATA CABLE	Refer to Note as below
I/O PORTS	Refer to user's manual
ACCESSORY DEVICES	Refer to Note as below

NOTE:

1. The EUT contains following accessories.

AC Adapter	Brand Name	Motorola
	Model Name	DC4050US0301
	Power Rating	I/P: 100-240Vac, 200mA; O/P: 5.1Vdc, 850mA
Battery	Brand Name	Motorola
	Model Name	EG30
	Power Rating	3.8Vdc, 1940/2000mAh
	Type	Li-ion
Earphone	Brand Name	Motorola
	Model Name	NA
	Signal Line Type	1.45 meter non-shielded cable without ferrite core
USB Cable	Brand Name	Motorola
	Model Name	NA
	Signal Line Type	1.05 meter non-shielded cable without ferrite core



A D T

2. The EUT provides one completed transmitter and one receiver.

MODULATION MODE	TX FUNCTION
802.11b	1TX
802.11g	1TX
802.11n (20MHz)	1TX
802.11n (40MHz)	1TX

3. The above EUT information is declared by the manufacturer and for more detailed features description, please refer to the manufacturer's specifications or User's Manual.

3.2 DESCRIPTION OF TEST MODES

FOR 2.4GHz:

11 channels are provided for 802.11b, 802.11g and 802.11n (20MHz):

CHANNEL	FREQUENCY	CHANNEL	FREQUENCY
1	2412MHz	7	2442MHz
2	2417MHz	8	2447MHz
3	2422MHz	9	2452MHz
4	2427MHz	10	2457MHz
5	2432MHz	11	2462MHz
6	2437MHz		

7 channels are provided for 802.11n (40MHz):

CHANNEL	FREQUENCY	CHANNEL	FREQUENCY
3	2422MHz	7	2442MHz
4	2427MHz	8	2447MHz
5	2432MHz	9	2452MHz
6	2437MHz		



3.2.1 TEST MODE APPLICABILITY AND TESTED CHANNEL DETAIL

FOR 2.4GHz:

EUT CONFIGURE MODE	APPLICABLE TO				DESCRIPTION
	RE≥1G	RE<1G	PLC	APCM	
-	√	√	√	√	-

Where **RE≥1G**: Radiated Emission above 1GHz **RE<1G**: Radiated Emission below 1GHz
PLC: Power Line Conducted Emission **APCM**: Antenna Port Conducted Measurement

NOTE: The EUT had been pre-tested on the positioned of each 3 axis. The worst case was found when positioned on X-plane.

RADIATED EMISSION TEST (ABOVE 1GHz):

- Pre-Scan has been conducted to determine the worst-case mode from all possible combinations between available modulations, data rates and antenna ports (if EUT with antenna diversity architecture).
- Following channel(s) was (were) selected for the final test as listed below.

MODE	AVAILABLE CHANNEL	TESTED CHANNEL	MODULATION TECHNOLOGY	MODULATION TYPE	DATA RATE (Mbps)
802.11b	1 to 11	1, 6, 11	DSSS	DBPSK	1.0
802.11g	1 to 11	1, 6, 11	OFDM	BPSK	6.0
802.11n (20MHz)	1 to 11	1, 6, 11	OFDM	BPSK	6.5
802.11n (40MHz)	3 to 9	3, 6, 9	OFDM	BPSK	13.5

RADIATED EMISSION TEST (BELOW 1GHz):

- Pre-Scan has been conducted to determine the worst-case mode from all possible combinations between available modulations, data rates and antenna ports (if EUT with antenna diversity architecture).
- Following channel(s) was (were) selected for the final test as listed below.

MODE	AVAILABLE CHANNEL	TESTED CHANNEL	MODULATION TECHNOLOGY	MODULATION TYPE	DATA RATE (Mbps)
802.11g	1 to 11	6	OFDM	BPSK	6.0

POWER LINE CONDUCTED EMISSION TEST:

- Pre-Scan has been conducted to determine the worst-case mode from all possible combinations between available modulations, data rates and antenna ports (if EUT with antenna diversity architecture).
- Following channel(s) was (were) selected for the final test as listed below.

MODE	AVAILABLE CHANNEL	TESTED CHANNEL	MODULATION TECHNOLOGY	MODULATION TYPE	DATA RATE (Mbps)
802.11g	1 to 11	6	OFDM	BPSK	6.0



BANDEDGE MEASUREMENT:

- Pre-Scan has been conducted to determine the worst-case mode from all possible combinations between available modulations, data rates and antenna ports (if EUT with antenna diversity architecture).
- Following channel(s) was (were) selected for the final test as listed below.

MODE	AVAILABLE CHANNEL	TESTED CHANNEL	MODULATION TECHNOLOGY	MODULATION TYPE	DATA RATE (Mbps)
802.11b	1 to 11	1, 11	DSSS	DBPSK	1.0
802.11g	1 to 11	1, 11	OFDM	BPSK	6.0
802.11n (20MHz)	1 to 11	1, 11	OFDM	BPSK	6.5
802.11n (40MHz)	3 to 9	3, 9	OFDM	BPSK	13.5

NOTE: Channel 2 and Channel 10 were evaluated for band edge and found compliant.

ANTENNA PORT CONDUCTED MEASUREMENT:

- This item includes all test value of each mode, but only includes spectrum plot of worst value of each mode.
- Pre-Scan has been conducted to determine the worst-case mode from all possible combinations between available modulations, data rates and antenna ports (if EUT with antenna diversity architecture).
- Following channel(s) was (were) selected for the final test as listed below.

MODE	AVAILABLE CHANNEL	TESTED CHANNEL	MODULATION TECHNOLOGY	MODULATION TYPE	DATA RATE (Mbps)
802.11b	1 to 11	1, 6, 11	DSSS	DBPSK	1.0
802.11g	1 to 11	1, 6, 11	OFDM	BPSK	6.0
802.11n (20MHz)	1 to 11	1, 6, 11	OFDM	BPSK	6.5
802.11n (40MHz)	3 to 9	3, 6, 9	OFDM	BPSK	13.5

TEST CONDITION:

APPLICABLE TO	ENVIRONMENTAL CONDITIONS	INPUT POWER	TESTED BY
RE≥1G	25deg. C, 65%RH	120Vac, 60Hz	Kay Wu
RE<1G	25deg. C, 65%RH	120Vac, 60Hz	Kay Wu
PLC	25deg. C, 65%RH	120Vac, 60Hz	David Huang
APCM	25deg. C, 65%RH	120Vac, 60Hz	Howard Kao

3.3 DESCRIPTION OF SUPPORT UNITS

The EUT has been tested as an independent unit together with other necessary accessories or support units.

3.3.1 CONFIGURATION OF SYSTEM UNDER TEST

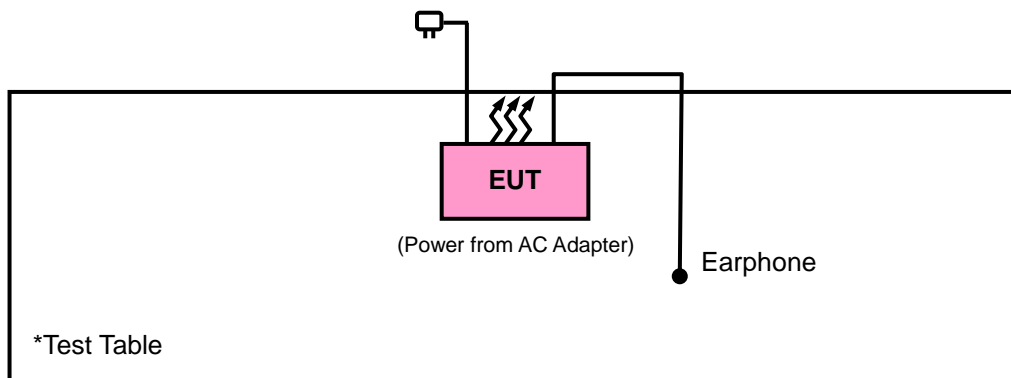

3.4 GENERAL DESCRIPTION OF APPLIED STANDARDS

The EUT is a RF Product. According to the specifications of the manufacturer, it must comply with the requirements of the following standards:

FCC Part 15, Subpart C (15.247)

KDB 558074 D01 DTS Meas Guidance v01

All test items have been performed and recorded as per the above standards.

NOTE: The EUT is also considered as a kind of computer peripheral, because the connection to computer is necessary for typical use. It has been verified to comply with the requirements of FCC Part 15, Subpart B, Class B. The test report has been issued separately.

4. TEST TYPES AND RESULTS

4.1 RADIATED EMISSION AND BANDEDGE MEASUREMENT

4.1.1 LIMITS OF RADIATED EMISSION AND BANDEDGE MEASUREMENT

Radiated emissions which fall in the restricted bands must comply with the radiated emission limits specified as below table. Other emissions shall be at least 20dB below the highest level of the desired power:

FREQUENCIES (MHz)	FIELD STRENGTH (microvolts/meter)	MEASUREMENT DISTANCE (meters)
0.009 ~ 0.490	2400/F(kHz)	300
0.490 ~ 1.705	24000/F(kHz)	30
1.705 ~ 30.0	30	30
30 ~ 88	100	3
88 ~ 216	150	3
216 ~ 960	200	3
Above 960	500	3

NOTE:

1. The lower limit shall apply at the transition frequencies.
2. Emission level (dBuV/m) = 20 log Emission level (uV/m).
3. For frequencies above 1000MHz, the field strength limits are based on average detector, however, the peak field strength of any emission shall not exceed the maximum permitted average limits, specified above by more than 20dB under any condition of modulation.



A D T

4.1.2 TEST INSTRUMENTS

DESCRIPTION & MANUFACTURER	MODEL NO.	SERIAL NO.	DATE OF CALIBRATION	DUE DATE OF CALIBRATION
Test Receiver Agilent	N9038A	MY51210203	Dec. 22, 2011	Dec. 21, 2012
Spectrum Analyzer ROHDE & SCHWARZ	FSU43	101261	Dec. 21, 2011	Dec. 20, 2012
BILOG Antenna SCHWARZBECK	VULB9168	9168-472	Dec. 20, 2011	Dec. 19, 2012
HORN Antenna SCHWARZBECK	BBHA 9120 D	9120D-969	Dec. 20, 2011	Dec. 19, 2012
HORN Antenna SCHWARZBECK	BBHA 9170	9170-480	Dec. 20, 2011	Dec. 19, 2012
Preamplifier EMCI	EMC 012645	980115	Dec. 30, 2011	Dec. 29, 2012
Preamplifier EMCI	EMC 330H	980112	Dec. 30, 2011	Dec. 29, 2012
RF signal cable HUBER+SUHNNER	SUCOFLEX 104	309219/4	Oct. 21, 2011	Oct. 20, 2012
RF signal cable HUBER+SUHNNER	SUCOFLEX 104	250130/4	Jan. 02, 2012	Jan. 01, 2013
RF signal cable Worken	RG-213	NA	Jan. 02, 2012	Jan. 01, 2013
Software	ADT_Radiated_ V7.6.15.9.2	NA	NA	NA
Antenna Tower EMCO	2070/2080	512.835.4684	NA	NA
Turn Table EMCO	2087-2.03	NA	NA	NA
26GHz ~ 40GHz Amplifier	EM26400	815221	Oct. 29, 2011	Oct. 28, 2012
Antenna Tower & Turn Table Controller MF	MF-7802	NA	NA	NA
JFW 20dB attenuation	50HF-020-SMA	NA	NA	NA
High Speed Peak Power Meter	ML2495A	0842014	Apr. 28, 2012	Apr. 27, 2013
Power Sensor	MA2411B	0738404	Apr. 28, 2012	Apr. 27, 2013

- NOTE:**
1. The calibration interval of the above test instruments is 12 months and the calibrations are traceable to NML/ROC and NIST/USA.
 2. The calibration interval of the loop antenna is 24 months and the calibrations are traceable to NML/ROC and NIST/USA.
 3. The test was performed in HwaYa Chamber 9.
 4. The horn antenna and HP preamplifier (model: 8449B) are used only for the measurement of emission frequency above 1GHz if tested.
 5. The FCC Site Registration No. is 460141.
 6. The IC Site Registration No. is IC 7450F-4.

4.1.3 TEST PROCEDURES

- a. The EUT was placed on the top of a rotating table 0.8 meters above the ground at a 3 meters semi-anechoic chamber. The table was rotated 360 degrees to determine the position of the highest radiation.
- b. The EUT was set 3 meters away from the interference-receiving antenna, which was mounted on the top of a variable-height antenna tower.
- c. Height of receiving antenna is varied from one meter to four meters above the ground to determine the maximum value of the field strength. Both horizontal and vertical polarizations of the antenna are set to make the measurement.
- d. For each suspected emission, the EUT was arranged to its worst case and then the antenna was tuned to heights from 1 meter to 4 meters and the rotatable table was turned from 0 degrees to 360 degrees to find the maximum reading.
- e. The test-receiver system was set to Peak Detect Function and Specified Bandwidth with Maximum Hold Mode.
- f. If the emission level of the EUT in peak mode was lower than the limit specified, then testing could be stopped and the peak values of the EUT would be reported. Otherwise the emissions would be re-tested one by one using peak, quasi-peak or average method as specified and then reported in a data sheet.

NOTE:

1. The resolution bandwidth and video bandwidth of test receiver/spectrum analyzer is 120kHz for Quasi-peak detection at frequency below 1GHz.
2. The resolution bandwidth of test receiver/spectrum analyzer is 1MHz and video bandwidth is 3MHz for Peak detection at frequency above 1GHz.
3. The resolution bandwidth of test receiver/spectrum analyzer is 1MHz and the video bandwidth is 10Hz for Average detection (AV) at frequency above 1GHz.
4. All modes of operation were investigated and the worst-case emissions are reported.

4.1.4 DEVIATION FROM TEST STANDARD

No deviation.

4.1.5 TEST SETUP

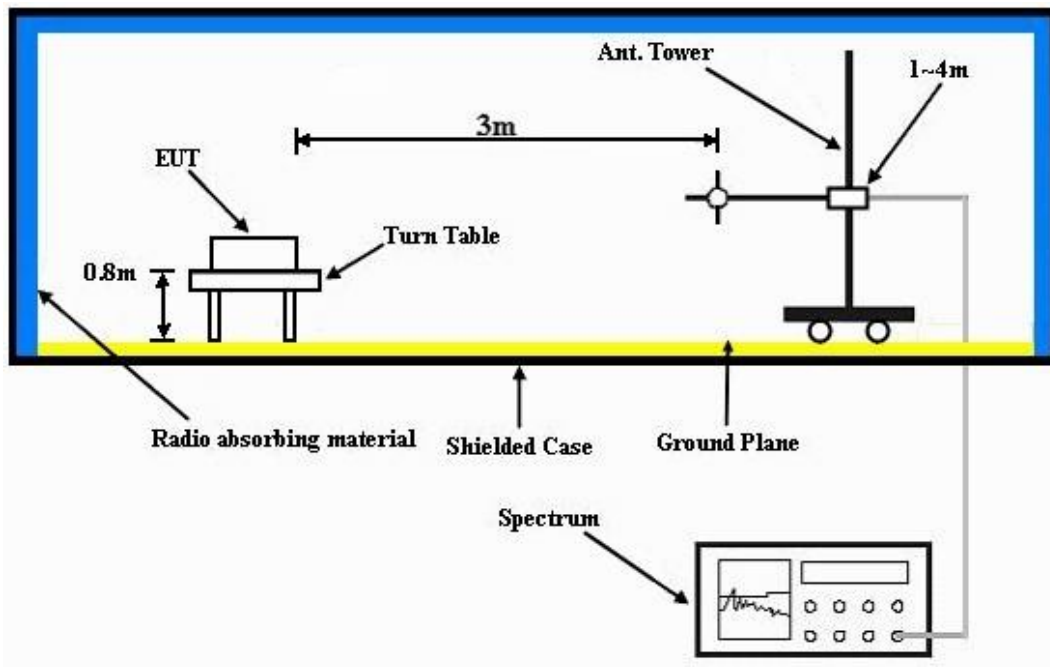

For the actual test configuration, please refer to the attached file (Test Setup Photo).

4.1.6 EUT OPERATING CONDITIONS

- a. Placed the EUT on a testing table.
- b. Use the software to control the EUT under transmission condition continuously at specific channel frequency.



A D T

4.1.7 TEST RESULTS

ABOVE 1GHz WORST-CASE DATA :

802.11b



Bureau Veritas Consumer Products Services Ltd., Taoyuan Branch

A D T

Data: 19

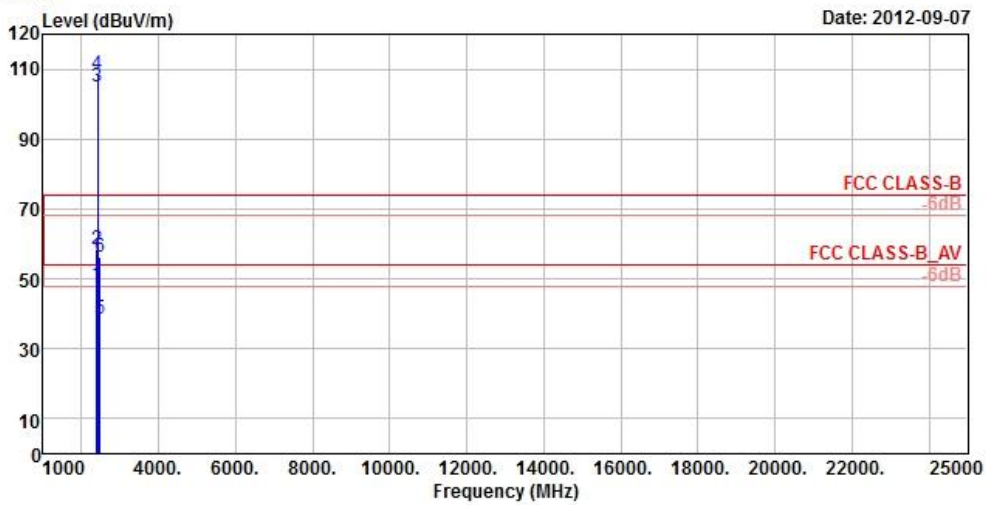

Date: 2012-09-07

Site : 966 Chamber 5
 Condition : FCC CLASS-B 3m ANT_18G~40G_HF HORIZONTAL
 Brand/Model: XT901
 Remark : 11B TX CH01
 Tested by : Kay Wu
 Temperature : 25°C
 Humidity : 65%
 Plane : X
 Rate : 1M
 Power : 16

	Freq	Level	Read Level	Limit Line	OverAntenna Limit	Antenna Factor	Cable Loss	Preamp Factor	A/Pos	T/Pos	Remark
	MHz	dBuV/m	dBuV	dBuV/m	dB	dB/m	dB	dB	cm	deg	
1 !	2388.00	48.41	53.80	54.00	-5.59	27.26	4.85	37.50	126	119	Average
2	2388.00	58.49	63.88	74.00	-15.51	27.26	4.85	37.50	126	119	Peak
3 pp	2412.00	104.93	110.27			27.31	4.87	37.52	126	119	Average
4 pk	2412.00	108.62	113.96			27.31	4.87	37.52	126	119	Peak
5	2483.50	38.42	43.32	54.00	-15.58	27.50	4.92	37.32	126	119	Average
6	2483.50	56.34	61.24	74.00	-17.66	27.50	4.92	37.32	126	119	Peak



A D T



Bureau Veritas Consumer Products Services Ltd., Taoyuan Branch

A D T

Data: 20

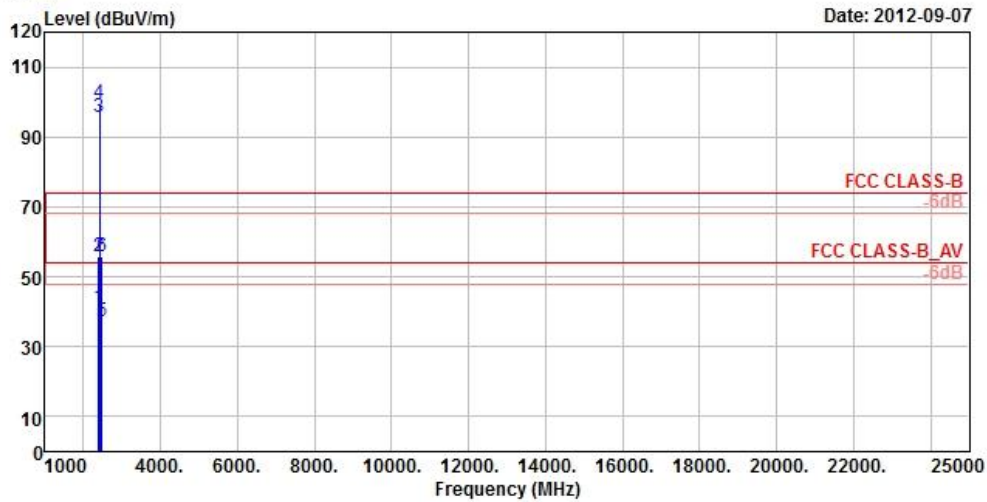

Site : 966 Chamber 5
 Condition : FCC CLASS-B 3m ANT_18G~40G_HF VERTICAL
 Brand/Model: XT901
 Remark : 11B TX CH01
 Tested by : Kay Wu
 Temperature : 25°C
 Humidity : 65%
 Plane : X
 Rate : 1M
 Power : 16

	Freq	Level	Read Level	Limit Line	OverAntenna Limit	Antenna Factor	Cable Loss	Preamp Factor	A/Pos	T/Pos	Remark
	MHz	dBuV/m	dBuV	dBuV/m	dB	dB/m	dB	dB	cm	deg	
1	2390.00	41.38	46.77	54.00	-12.62	27.26	4.87	37.52	100	9	Average
2	2390.00	55.58	60.97	74.00	-18.42	27.26	4.87	37.52	100	9	Peak
3 pp	2412.00	95.55	100.89			27.31	4.87	37.52	100	9	Average
4 pk	2412.00	99.42	104.76			27.31	4.87	37.52	100	9	Peak
5	2483.50	37.00	41.90	54.00	-17.00	27.50	4.92	37.32	100	9	Average
6	2483.50	55.72	60.62	74.00	-18.28	27.50	4.92	37.32	100	9	Peak



A D T



Bureau Veritas Consumer Products Services Ltd., Taoyuan Branch

A D T

Data: 19

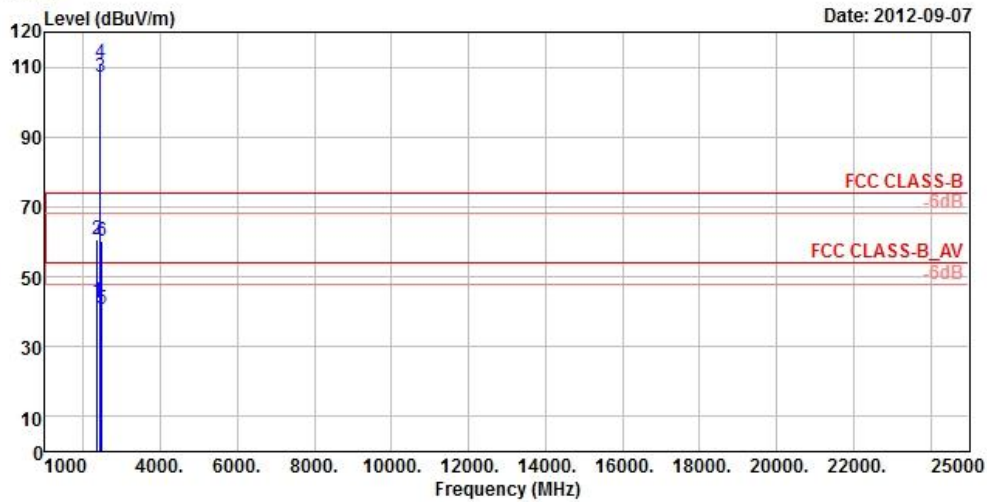

Site : 966 Chamber 5
 Condition : FCC CLASS-B 3m ANT_18G~40G_HF HORIZONTAL
 Brand/Model: XT901
 Remark : 11B TX CH06
 Tested by : Kay Wu
 Temperature : 25°C
 Humidity : 65%
 Plane : X
 Rate : 1M
 Power : 18

	Freq	Level	Read Level	Limit Line	OverAntenna Limit	Cable Factor	Preamp Loss	A/Pos	T/Pos	Remark
	MHz	dBuV/m	dBuV	dBuV/m	dB	dB/m	dB	dB	cm	deg
1	2354.00	42.82	48.33	54.00	-11.18	27.16	4.82	37.49	126	116 Average
2	2354.00	60.73	66.24	74.00	-13.27	27.16	4.82	37.49	126	116 Peak
3 pp	2437.00	107.24	112.41			27.40	4.89	37.46	126	116 Average
4 pk	2437.00	111.17	116.34			27.40	4.89	37.46	126	116 Peak
5	2483.50	40.83	45.73	54.00	-13.17	27.50	4.92	37.32	126	116 Average
6	2483.50	60.17	65.07	74.00	-13.83	27.50	4.92	37.32	126	116 Peak



A D T



Bureau Veritas Consumer Products Services Ltd., Taoyuan Branch

A D T

Data: 20

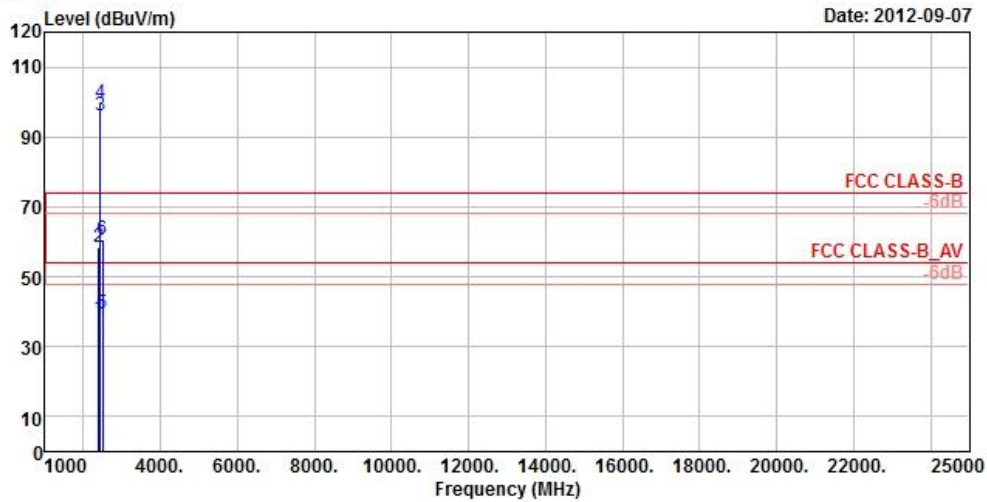

Date: 2012-09-07

Site : 966 Chamber 5
 Condition : FCC CLASS-B 3m ANT_18G~40G_HF VERTICAL
 Brand/Model: XT901
 Remark : 11B TX CH06
 Tested by : Kay Wu
 Temperature : 25°C
 Humidity : 65%
 Plane : X
 Rate : 1M
 Power : 18

	Freq	Level	Read Level	Limit Line	OverAntenna Limit	Cable Factor	Preamp Loss	A/Pos	T/Pos	Remark
	MHz	dBuV/m	dBuV	dBuV/m	dB	dB/m	dB	dB	cm	deg
1	2390.00	37.97	43.36	54.00	-16.03	27.26	4.87	37.52	100	10 Average
2	2390.00	58.55	63.94	74.00	-15.45	27.26	4.87	37.52	100	10 Peak
3 pp	2437.00	95.99	101.16			27.40	4.89	37.46	100	10 Average
4 pk	2437.00	99.84	105.01			27.40	4.89	37.46	100	10 Peak
5	2498.00	39.47	44.23	54.00	-14.53	27.55	4.94	37.25	100	10 Average
6	2498.00	60.67	65.43	74.00	-13.33	27.55	4.94	37.25	100	10 Peak



A D T



Bureau Veritas Consumer Products Services Ltd., Taoyuan Branch

A D T

Data: 19

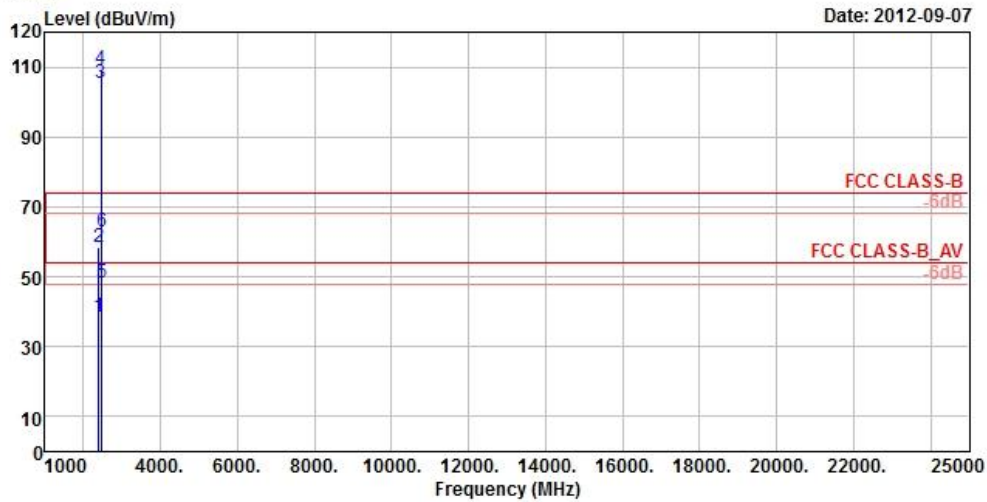

Site : 966 Chamber 5
 Condition : FCC CLASS-B 3m ANT_18G~40G_HF HORIZONTAL
 Brand/Model: XT901
 Remark : 11B TX CH11
 Tested by : Kay Wu
 Temperature : 25°C
 Humidity : 65%
 Plane : X
 Rate : 1M
 Power : 17

	Freq	Level	Read Level	Limit Line	OverLimit	Antenna Factor	Cable Loss	Preamp Factor	A/Pos	T/Pos	Remark
	MHz	dBuV/m	dBuV	dBuV/m	dB	dB/m	dB	dB	cm	deg	
1	2390.00	38.52	43.91	54.00	-15.48	27.26	4.87	37.52	125	112	Average
2	2390.00	58.55	63.94	74.00	-15.45	27.26	4.87	37.52	125	112	Peak
3	pp 2462.00	105.29	110.32			27.45	4.91	37.39	125	112	Average
4	pk 2462.00	109.56	114.59			27.45	4.91	37.39	125	112	Peak
5	! 2483.50	48.29	53.19	54.00	-5.71	27.50	4.92	37.32	125	112	Average
6	2483.50	62.76	67.66	74.00	-11.24	27.50	4.92	37.32	125	112	Peak



A D T



Bureau Veritas Consumer Products Services Ltd., Taoyuan Branch

A D T

Data: 20

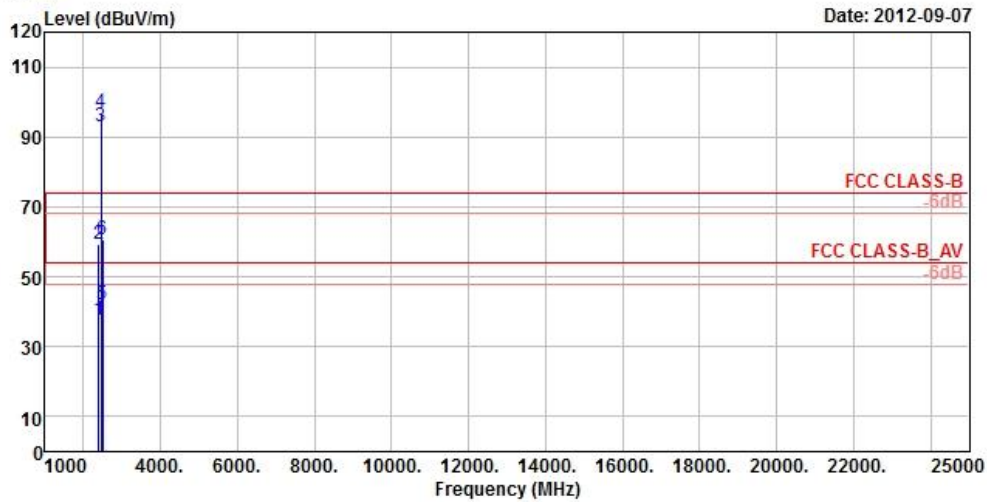

Site : 966 Chamber 5
 Condition : FCC CLASS-B 3m ANT_18G~40G_HF VERTICAL
 Brand/Model: XT901
 Remark : 11B TX CH11
 Tested by : Kay Wu
 Temperature : 25°C
 Humidity : 65%
 Plane : X
 Rate : 1M
 Power : 17

	Freq	Level	Read Level	Limit Line	OverAntenna Limit	Cable Factor	Preamp Loss	A/Pos	T/Pos	Remark
	MHz	dBuV/m	dBuV	dBuV/m	dB	dB/m	dB	dB	cm	deg
1	2390.00	37.54	42.93	54.00	-16.46	27.26	4.87	37.52	100	12 Average
2	2390.00	59.53	64.92	74.00	-14.47	27.26	4.87	37.52	100	12 Peak
3 pp	2462.00	93.12	98.15			27.45	4.91	37.39	100	12 Average
4 pk	2462.00	96.86	101.89			27.45	4.91	37.39	100	12 Peak
5	2494.00	41.85	46.61	54.00	-12.15	27.55	4.94	37.25	100	12 Average
6	2494.00	60.86	65.62	74.00	-13.14	27.55	4.94	37.25	100	12 Peak



A D T

802.11g



Bureau Veritas Consumer Products Services Ltd., Taoyuan Branch

A D T

Data: 20

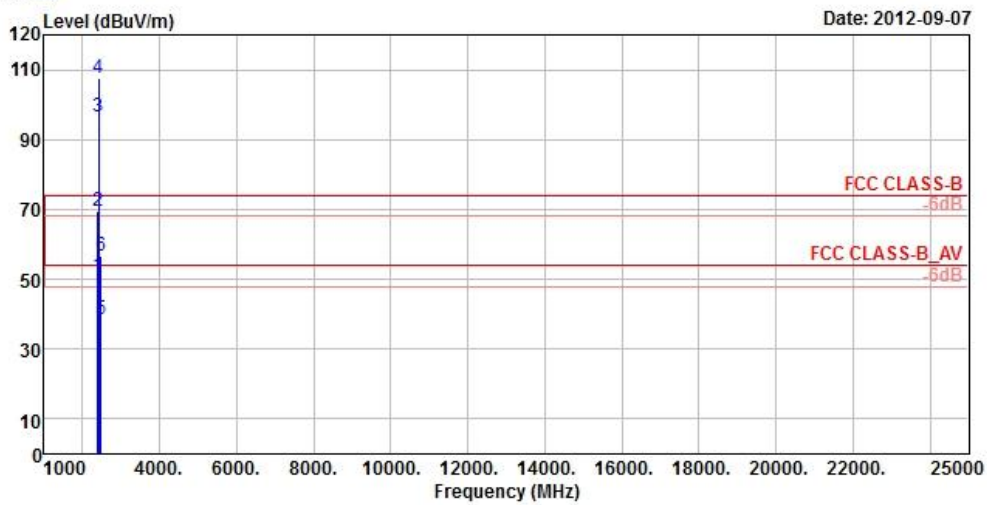

Date: 2012-09-07

Site : 966 Chamber 5
 Condition : FCC CLASS-B 3m ANT_18G~40G_HF HORIZONTAL
 Brand/Model: XT901
 Remark : 11G TX CH01
 Tested by : Kay Wu
 Temperature : 25°C
 Humidity : 65%
 Plane : X
 Rate : 6M
 Power : 13

	Read	Limit	OverAntenna	Cable	Preamp	A/Pos	T/Pos				
Remark	Level	Line	Limit	Loss	Factor	cm	deg				
	Freq	Level	Level	Factor	Factor						
	MHz	dBuV/m	dBuV	dBuV/m	dB	dB/m	dB	dB			
1 !	2390.00	50.78	56.17	54.00	-3.22	27.26	4.87	37.52	128	120	Average
2 !	2390.00	69.64	75.03	74.00	-4.36	27.26	4.87	37.52	128	120	Peak
3 pp	2412.00	96.33	101.67			27.31	4.87	37.52	128	120	Average
4 pk	2412.00	107.76	113.10			27.31	4.87	37.52	128	120	Peak
5	2483.50	38.52	43.42	54.00	-15.48	27.50	4.92	37.32	128	120	Average
6	2483.50	56.46	61.36	74.00	-17.54	27.50	4.92	37.32	128	120	Peak



A D T



Bureau Veritas Consumer Products Services Ltd., Taoyuan Branch

A D T

Data: 21

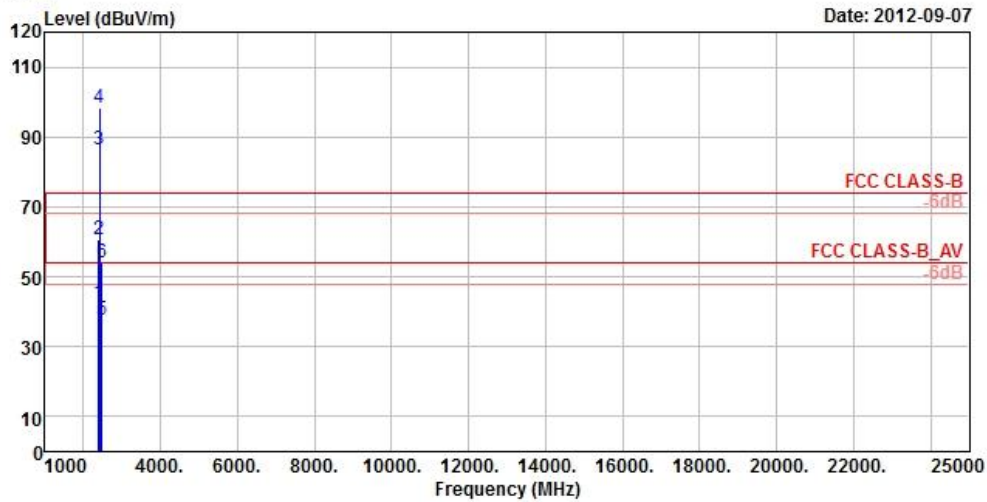

Site : 966 Chamber 5
 Condition : FCC CLASS-B 3m ANT_18G~40G_HF VERTICAL
 Brand/Model: XT901
 Remark : 11G TX CH01
 Tested by : Kay Wu
 Temperature : 25°C
 Humidity : 65%
 Plane : X
 Rate : 6M
 Power : 13

	Freq	Level	Read Level	Limit Line	OverAntenna Limit	Cable Factor	Preamp Loss	A/Pos	T/Pos	Remark
	MHz	dBuV/m	dBuV	dBuV/m	dB	dB/m	dB	dB	cm	deg
1	2390.00	42.33	47.72	54.00	-11.67	27.26	4.87	37.52	100	10 Average
2	2390.00	60.81	66.20	74.00	-13.19	27.26	4.87	37.52	100	10 Peak
3 pp	2412.00	86.47	91.81			27.31	4.87	37.52	100	10 Average
4 pk	2412.00	98.48	103.82			27.31	4.87	37.52	100	10 Peak
5	2483.50	37.52	42.42	54.00	-16.48	27.50	4.92	37.32	100	10 Average
6	2483.50	54.13	59.03	74.00	-19.87	27.50	4.92	37.32	100	10 Peak



A D T



Bureau Veritas Consumer Products Services Ltd., Taoyuan Branch

A D T

Data: 19

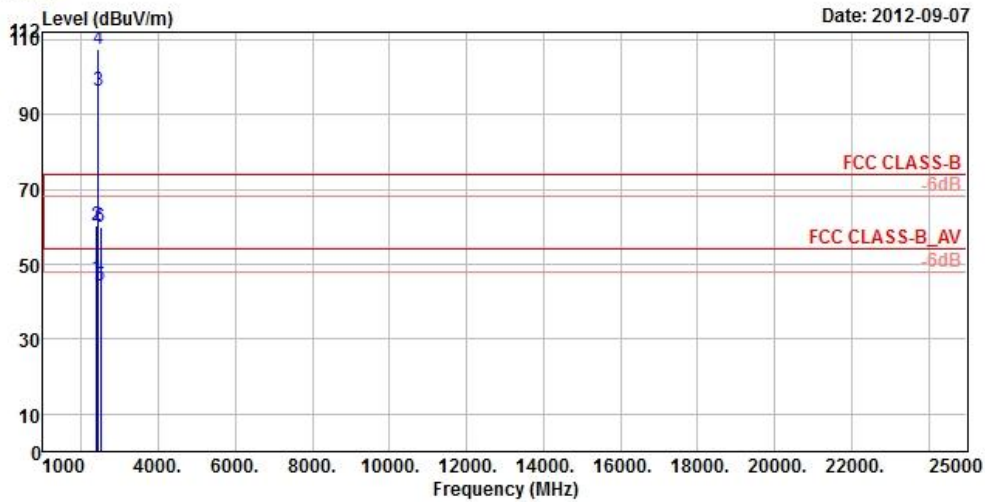

Site : 966 Chamber 5
 Condition : FCC CLASS-B 3m ANT_18G~40G_HF HORIZONTAL
 Brand/Model: XT901
 Remark : 11G TX CH06
 Tested by : Kay Wu
 Temperature : 25°C
 Humidity : 65%
 Plane : X
 Rate : 6M
 Power : 14

	Freq	Level	Read Level	Limit Line	OverAntenna Limit	Cable Factor	Preamp Loss	A/Pos	T/Pos	Remark
	MHz	dBuV/m	dBuV	dBuV/m	dB	dB/m	dB	dB	cm	deg
1	2390.00	46.26	51.65	54.00	-7.74	27.26	4.87	37.52	128	122 Average
2	2390.00	60.47	65.86	74.00	-13.53	27.26	4.87	37.52	128	122 Peak
3 pp	2437.00	96.25	101.42			27.40	4.89	37.46	128	122 Average
4 pk	2437.00	107.29	112.51			27.35	4.89	37.46	128	122 Peak
5	2490.00	44.26	49.11	54.00	-9.74	27.55	4.92	37.32	128	122 Average
6	2490.00	59.82	64.67	74.00	-14.18	27.55	4.92	37.32	128	122 Peak



A D T



Bureau Veritas Consumer Products Services Ltd., Taoyuan Branch

A D T

Data: 20

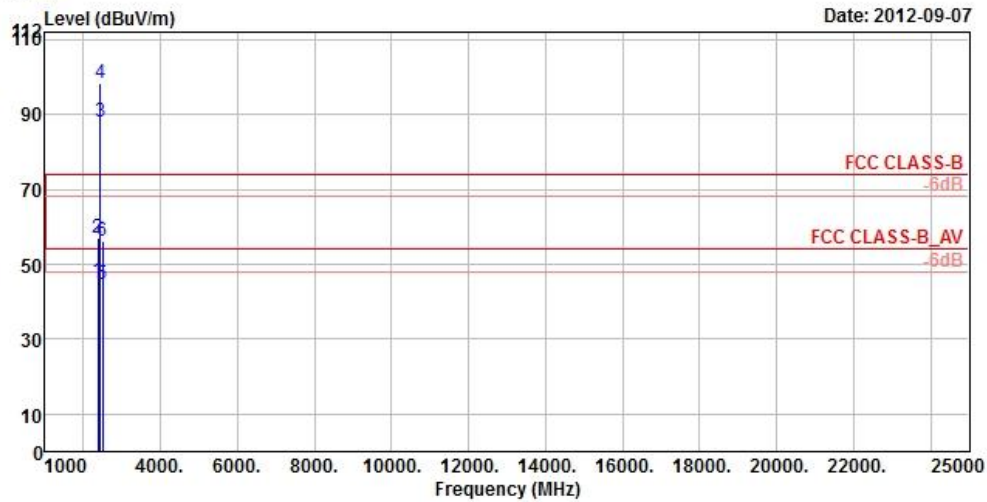

Site : 966 Chamber 5
 Condition : FCC CLASS-B 3m ANT_18G~40G_HF VERTICAL
 Brand/Model: XT901
 Remark : 11G TX CH06
 Tested by : Kay Wu
 Temperature : 25°C
 Humidity : 65%
 Plane : X
 Rate : 6M
 Power : 14

	Freq	Level	Read Level	Limit Line	OverAntenna Limit	Cable Factor	Preamp Loss	A/Pos	T/Pos	Remark
	MHz	dBUV/m	dBuV	dBUV/m	dB	dB/m	dB	dB	cm	deg
1	2380.00	45.26	50.70	54.00	-8.74	27.21	4.85	37.50	100	11 Average
2	2380.00	56.84	62.28	74.00	-17.16	27.21	4.85	37.50	100	11 Peak
3 pp	2437.00	87.86	93.03			27.40	4.89	37.46	100	11 Average
4 pk	2437.00	98.28	103.45			27.40	4.89	37.46	100	11 Peak
5	2494.00	44.56	49.32	54.00	-9.44	27.55	4.94	37.25	100	11 Average
6	2494.00	56.27	61.03	74.00	-17.73	27.55	4.94	37.25	100	11 Peak



A D T



Bureau Veritas Consumer Products Services Ltd., Taoyuan Branch

A D T

Data: 19

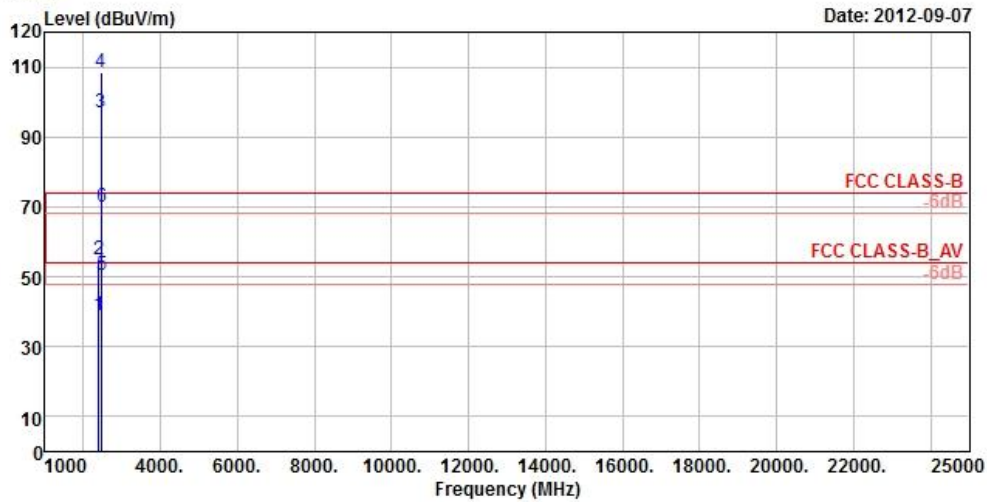

Site : 966 Chamber 5
 Condition : FCC CLASS-B 3m ANT_18G~40G_HF HORIZONTAL
 Brand/Model: XT901
 Remark : 11G TX CH11
 Tested by : Kay Wu
 Temperature : 25°C
 Humidity : 65%
 Plane : X
 Rate : 6M
 Power : 13

	Freq	Level	Read Level	Limit Line	OverAntenna Limit	Cable Factor	Preamp Loss	A/Pos	T/Pos	Remark
	MHz	dBuV/m	dBuV	dBuV/m	dB	dB/m	dB	dB	cm	deg
1	2390.00	38.98	44.37	54.00	-15.02	27.26	4.87	37.52	127	118 Average
2	2390.00	54.99	60.38	74.00	-19.01	27.26	4.87	37.52	127	118 Peak
3 pp	2462.00	96.88	101.91			27.45	4.91	37.39	127	118 Average
4 pk	2462.00	108.70	113.73			27.45	4.91	37.39	127	118 Peak
5 !	2483.50	50.38	55.28	54.00	-3.62	27.50	4.92	37.32	127	118 Average
6 !	2483.50	70.06	74.96	74.00	-3.94	27.50	4.92	37.32	127	118 Peak



A D T



Bureau Veritas Consumer Products Services Ltd., Taoyuan Branch

A D T

Data: 20

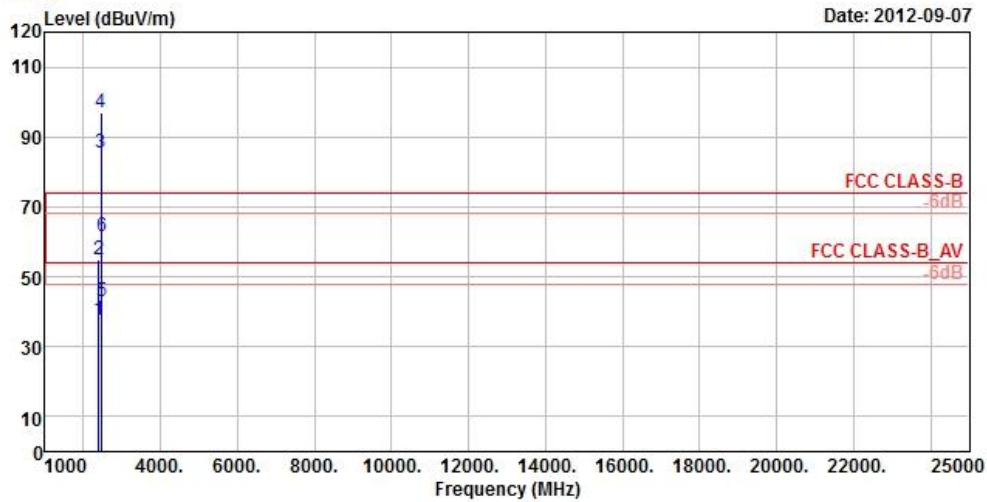

Date: 2012-09-07

Site : 966 Chamber 5
 Condition : FCC CLASS-B 3m ANT_18G~40G_HF VERTICAL
 Brand/Model: XT901
 Remark : 11G TX CH11
 Tested by : Kay Wu
 Temperature : 25°C
 Humidity : 65%
 Plane : X
 Rate : 6M
 Power : 13

	Freq	Level	Read Level	Limit Line	OverAntenna Limit	Cable Factor	Preamp Loss	A/Pos	T/Pos	Remark
	MHz	dBuV/m	dBuV	dBuV/m	dB	dB/m	dB	dB	cm	deg
1	2390.00	37.45	42.84	54.00	-16.55	27.26	4.87	37.52	100	11 Average
2	2390.00	54.87	60.26	74.00	-19.13	27.26	4.87	37.52	100	11 Peak
3 pp	2462.00	85.41	90.44			27.45	4.91	37.39	100	11 Average
4 pk	2462.00	97.17	102.20			27.45	4.91	37.39	100	11 Peak
5	2483.50	42.94	47.84	54.00	-11.06	27.50	4.92	37.32	100	11 Average
6	2483.50	61.42	66.32	74.00	-12.58	27.50	4.92	37.32	100	11 Peak

802.11n (20MHz)



Bureau Veritas Consumer Products Services Ltd., Taoyuan Branch

A D T

Data: 19

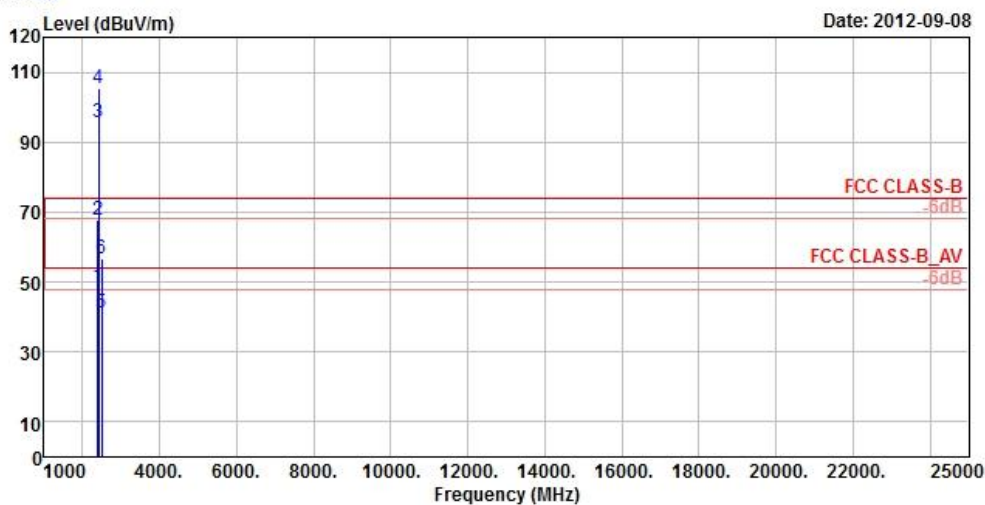

Site : 966 Chamber 5
 Condition : FCC CLASS-B 3m ANT_18G~40G_HF HORIZONTAL
 Brand/Model: XT901
 Remark : 11N_HT20 TX CH01
 Tested by : Kay Wu
 Temperature : 25°C
 Humidity : 65%
 Plane : X
 Rate : MCS0
 Power : 12

	Read	Limit	OverAntenna	Cable	Preamp	A/Pos	T/Pos	Remark			
Freq	Level	Level	Line	Loss	Loss						
MHz	dBuV/m	dBuV	dBuV/m	dB	dB/m	dB	dB	cm deg			
1 !	2390.00	48.79	54.18	54.00	-5.21	27.26	4.87	37.52	130	119	Average
2	2390.00	67.83	73.22	74.00	-6.17	27.26	4.87	37.52	130	119	Peak
3 pp	2412.00	95.64	100.98			27.31	4.87	37.52	130	119	Average
4 pk	2412.00	105.58	110.92			27.31	4.87	37.52	130	119	Peak
5	2492.00	41.12	45.88	54.00	-12.88	27.55	4.94	37.25	130	119	Average
6	2492.00	56.49	61.25	74.00	-17.51	27.55	4.94	37.25	130	119	Peak



A D T



Bureau Veritas Consumer Products Services Ltd., Taoyuan Branch

A D T

Data: 20

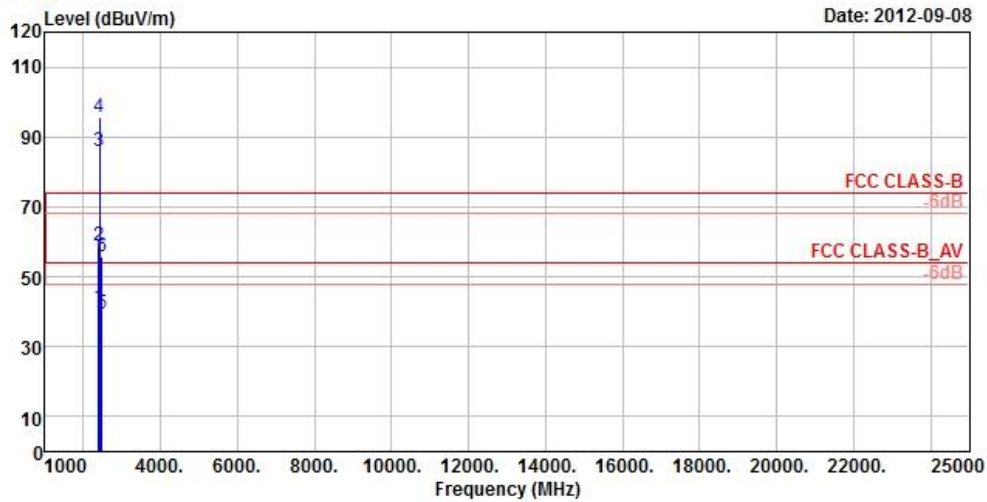

Site : 966 Chamber 5
 Condition : FCC CLASS-B 3m ANT_18G~40G_HF VERTICAL
 Brand/Model: XT901
 Remark : 11N_HT20 TX CH01
 Tested by : Kay Wu
 Temperature : 25°C
 Humidity : 65%
 Plane : X
 Rate : MCS0
 Power : 12

	Freq	Level	Read Level	Limit Line	OverAntenna Limit	Antenna Factor	Cable Loss	Preamp Factor	A/Pos	T/Pos	Remark
	MHz	dBuV/m	dBuV	dBuV/m	dB	dB/m	dB	dB	cm	deg	
1	2390.00	41.28	46.67	54.00	-12.72	27.26	4.87	37.52	100	10	Average
2	2390.00	59.07	64.46	74.00	-14.93	27.26	4.87	37.52	100	10	Peak
3	pp 2412.00	85.71	91.05			27.31	4.87	37.52	100	10	Average
4	pk 2412.00	95.75	101.09			27.31	4.87	37.52	100	10	Peak
5	2483.50	39.29	44.19	54.00	-14.71	27.50	4.92	37.32	100	10	Average
6	2483.50	55.60	60.50	74.00	-18.40	27.50	4.92	37.32	100	10	Peak



A D T



Bureau Veritas Consumer Products Services Ltd., Taoyuan Branch

A D T

Data: 19

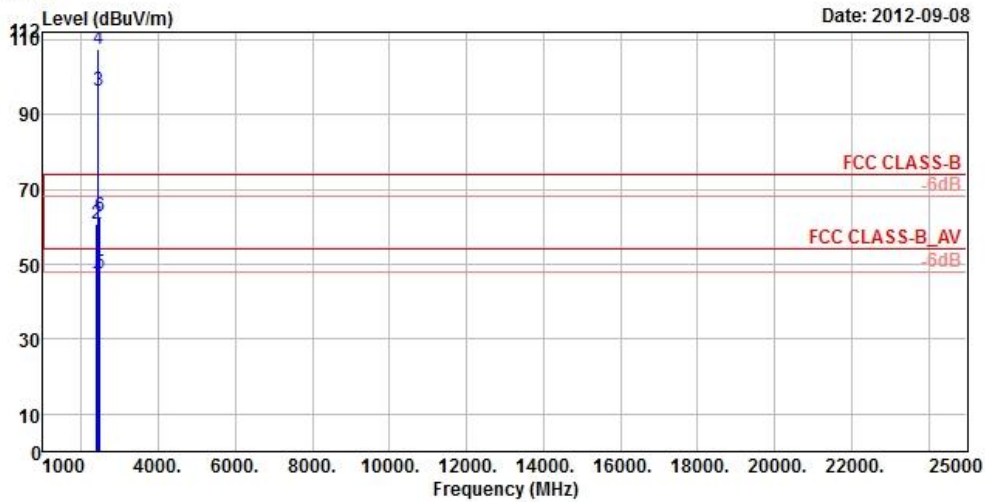

Site : 966 Chamber 5
 Condition : FCC CLASS-B 3m ANT_18G~40G_HF HORIZONTAL
 Brand/Model: XT901
 Remark : 11N_HT20 TX CH06
 Tested by : Kay Wu
 Temperature : 25°C
 Humidity : 65%
 Plane : X
 Rate : MCS0
 Power : 14

	Freq	Level	Read Level	Limit Line	OverAntenna Limit	Cable Factor	Preamp Loss	A/Pos	T/Pos	Remark
	MHz	dBuV/m	dBuV	dBuV/m	dB	dB/m	dB	dB	cm	deg
1	2386.00	45.18	50.57	54.00	-8.82	27.26	4.85	37.50	127	120 Average
2	2386.00	60.92	66.31	74.00	-13.08	27.26	4.85	37.50	127	120 Peak
3 pp	2437.00	96.45	101.62			27.40	4.89	37.46	127	120 Average
4 pk	2437.00	107.44	112.52			27.40	4.91	37.39	127	120 Peak
5	2484.00	47.51	52.41	54.00	-6.49	27.50	4.92	37.32	127	120 Average
6	2484.00	62.64	67.54	74.00	-11.36	27.50	4.92	37.32	127	120 Peak



A D T



Bureau Veritas Consumer Products Services Ltd., Taoyuan Branch

A D T

Data: 20

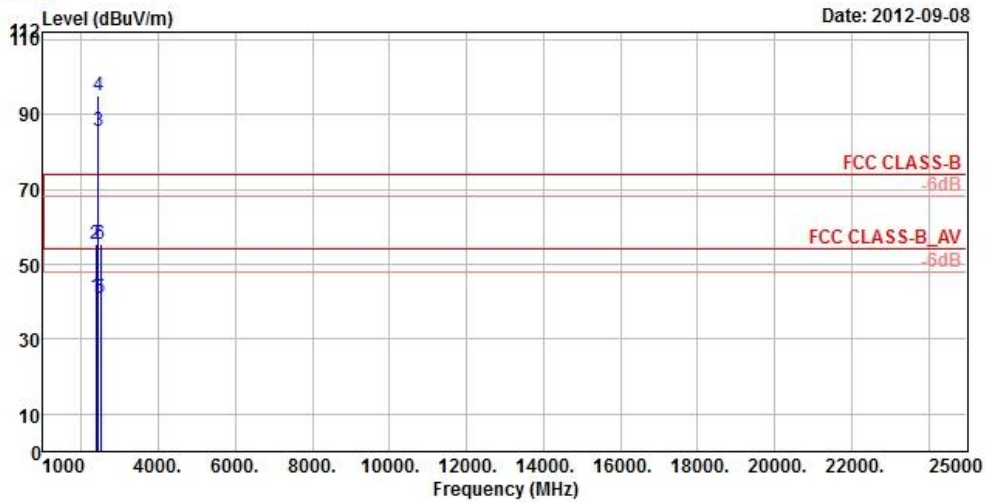

Site : 966 Chamber 5
 Condition : FCC CLASS-B 3m ANT_18G~40G_HF VERTICAL
 Brand/Model: XT901
 Remark : 11N_HT20 TX CH06
 Tested by : Kay Wu
 Temperature : 25°C
 Humidity : 65%
 Plane : X
 Rate : MCS0
 Power : 14

	Freq	Level	Read Level	Limit Line	OverAntenna Limit	Cable Factor	Preamp Loss	A/Pos	T/Pos	Remark
	MHz	dBuV/m	dBuV	dBuV/m	dB	dB/m	dB	dB	cm	deg
1	2380.00	41.52	46.96	54.00	-12.48	27.21	4.85	37.50	100	10 Average
2	2380.00	55.46	60.90	74.00	-18.54	27.21	4.85	37.50	100	10 Peak
3 pp	2437.00	85.44	90.61			27.40	4.89	37.46	100	10 Average
4 pk	2437.00	95.03	100.11			27.40	4.91	37.39	100	10 Peak
5	2498.00	41.02	45.78	54.00	-12.98	27.55	4.94	37.25	100	10 Average
6	2498.00	55.57	60.33	74.00	-18.43	27.55	4.94	37.25	100	10 Peak



A D T



Bureau Veritas Consumer Products Services Ltd., Taoyuan Branch

A D T

Data: 19

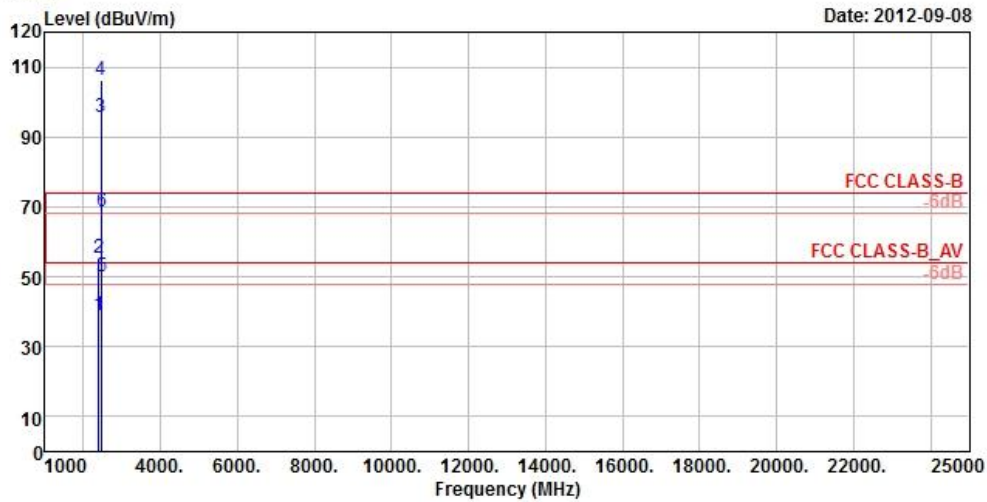

Site : 966 Chamber 5
 Condition : FCC CLASS-B 3m ANT_18G~40G_HF HORIZONTAL
 Brand/Model: XT901
 Remark : 11N_HT20 TX CH11
 Tested by : Kay Wu
 Temperature : 25°C
 Humidity : 65%
 Plane : X
 Rate : MCS0
 Power : 13

	Freq	Level	Read Level	Limit Line	OverAntenna Limit	Cable Factor	Preamp Loss	A/Pos	T/Pos	Remark
	MHz	dBuV/m	dBuV	dBuV/m	dB	dB/m	dB	dB	cm	deg
1	2390.00	39.11	44.50	54.00	-14.89	27.26	4.87	37.52	126	120 Average
2	2390.00	55.42	60.81	74.00	-18.58	27.26	4.87	37.52	126	120 Peak
3 pp	2462.00	95.56	100.59			27.45	4.91	37.39	126	120 Average
4 pk	2462.00	106.32	111.35			27.45	4.91	37.39	126	120 Peak
5 !	2483.50	49.92	54.82	54.00	-4.08	27.50	4.92	37.32	126	120 Average
6 !	2483.50	68.72	73.62	74.00	-5.28	27.50	4.92	37.32	126	120 Peak



A D T



Bureau Veritas Consumer Products Services Ltd., Taoyuan Branch

A D T

Data: 20

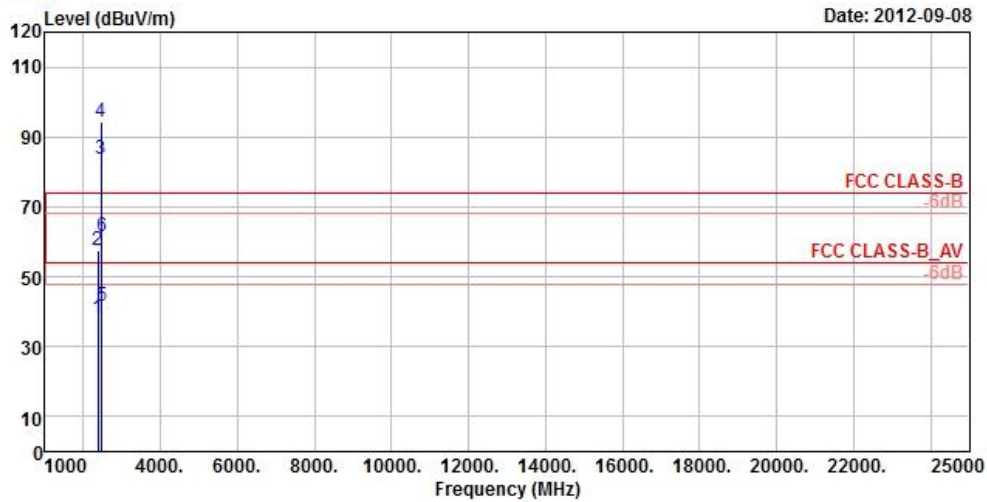

Site : 966 Chamber 5
 Condition : FCC CLASS-B 3m ANT_18G~40G_HF VERTICAL
 Brand/Model: XT901
 Remark : 11N_HT20 TX CH11
 Tested by : Kay Wu
 Temperature : 25°C
 Humidity : 65%
 Plane : X
 Rate : MCS0
 Power : 13

	Freq	Level	Read Level	Limit Line	OverAntenna Limit	Cable Factor	Preamp Loss	A/Pos	T/Pos	Remark
	MHz	dBuV/m	dBuV	dBuV/m	dB	dB/m	dB	dB	cm	deg
1	2370.00	38.02	43.46	54.00	-15.98	27.21	4.85	37.50	100	12 Average
2	2370.00	57.45	62.89	74.00	-16.55	27.21	4.85	37.50	100	12 Peak
3 pp	2462.00	83.71	88.74			27.45	4.91	37.39	100	12 Average
4 pk	2462.00	94.21	99.24			27.45	4.91	37.39	100	12 Peak
5	2483.50	41.80	46.70	54.00	-12.20	27.50	4.92	37.32	100	12 Average
6	2483.50	61.49	66.39	74.00	-12.51	27.50	4.92	37.32	100	12 Peak



A D T

802.11n (40MHz)



Bureau Veritas Consumer Products Services Ltd., Taoyuan Branch

A D T

Data: 19

Date: 2012-09-08

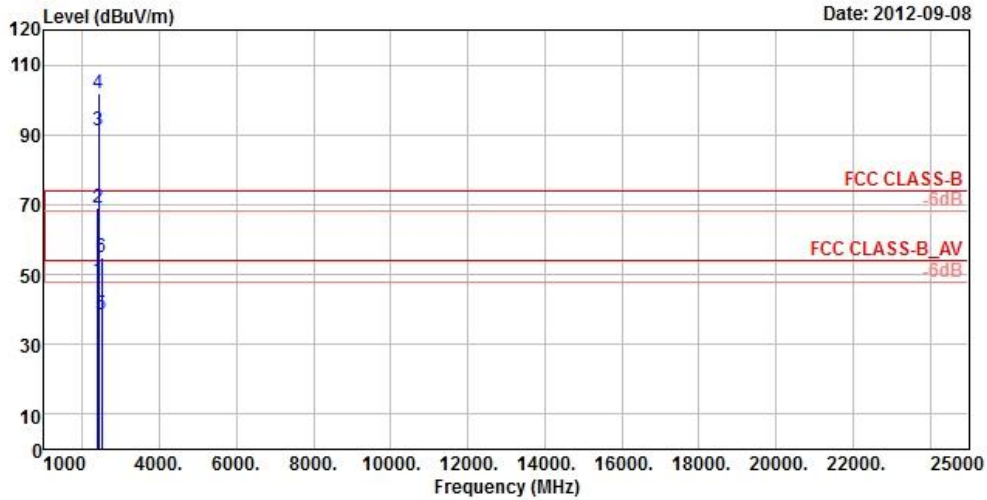

Site : 966 Chamber 5
 Condition : FCC CLASS-B 3m ANT_18G~40G_HF HORIZONTAL
 Brand/Model: XT901
 Remark : 11N_HT40 TX CH03
 Tested by : Kay Wu
 Temperature : 25°C
 Humidity : 65%
 Plane : X
 Rate : MCS0
 Power : 12

	Read	Limit	OverAntenna	Cable	Preamp	A/Pos	T/Pos	Remark		
Freq	Level	Level	Line	Loss	Loss					
MHz	dBuV/m	dBuV	dBuV/m	dB	dB/m	dB	dB	cm	deg	
1 !	2390.00	48.45	53.84	54.00	-5.55	27.26	4.87	37.52	130	115 Average
2 !	2390.00	69.25	74.64	74.00	-4.75	27.26	4.87	37.52	130	115 Peak
3 pp	2422.00	91.11	96.33			27.35	4.89	37.46	130	115 Average
4 pk	2422.00	101.66	106.88			27.35	4.89	37.46	130	115 Peak
5	2500.00	38.44	43.20	54.00	-15.56	27.55	4.94	37.25	130	115 Average
6	2500.00	54.96	59.72	74.00	-19.04	27.55	4.94	37.25	130	115 Peak



A D T



Bureau Veritas Consumer Products Services Ltd., Taoyuan Branch

A D T

Data: 20

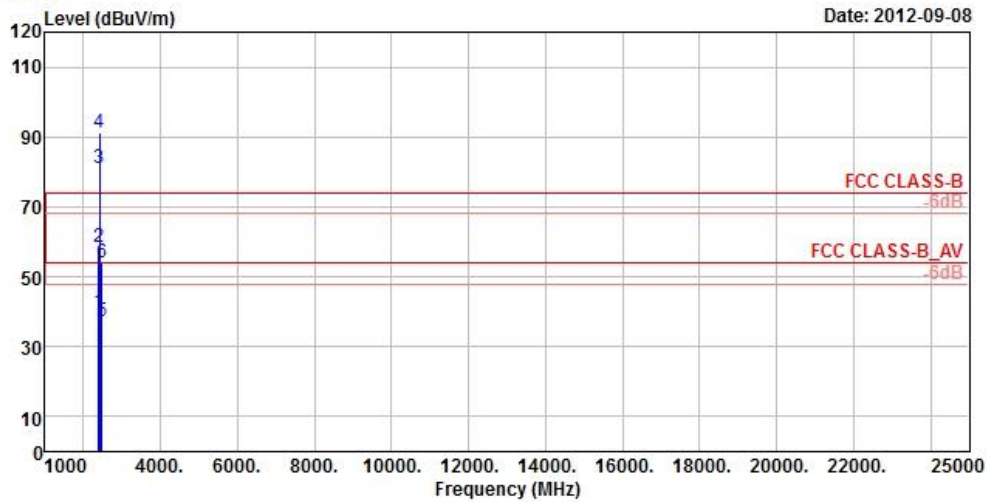

Site : 966 Chamber 5
 Condition : FCC CLASS-B 3m ANT_18G~40G_HF VERTICAL
 Brand/Model: XT901
 Remark : 11N_HT40 TX CH03
 Tested by : Kay Wu
 Temperature : 25°C
 Humidity : 65%
 Plane : X
 Rate : MCS0
 Power : 12

	Freq	Level	Read Level	Limit Line	OverAntenna Limit	Cable Factor	Preamp Loss	A/Pos	T/Pos	Remark
	MHz	dBuV/m	dBuV	dBuV/m	dB	dB/m	dB	dB	cm	deg
1	2390.00	39.89	45.28	54.00	-14.11	27.26	4.87	37.52	100	9 Average
2	2390.00	58.31	63.70	74.00	-15.69	27.26	4.87	37.52	100	9 Peak
3 pp	2422.00	80.97	86.19			27.35	4.89	37.46	100	9 Average
4 pk	2422.00	91.31	96.53			27.35	4.89	37.46	100	9 Peak
5	2484.00	37.23	42.13	54.00	-16.77	27.50	4.92	37.32	100	9 Average
6	2484.00	54.08	58.98	74.00	-19.92	27.50	4.92	37.32	100	9 Peak



A D T



Bureau Veritas Consumer Products Services Ltd., Taoyuan Branch

A D T

Data: 19

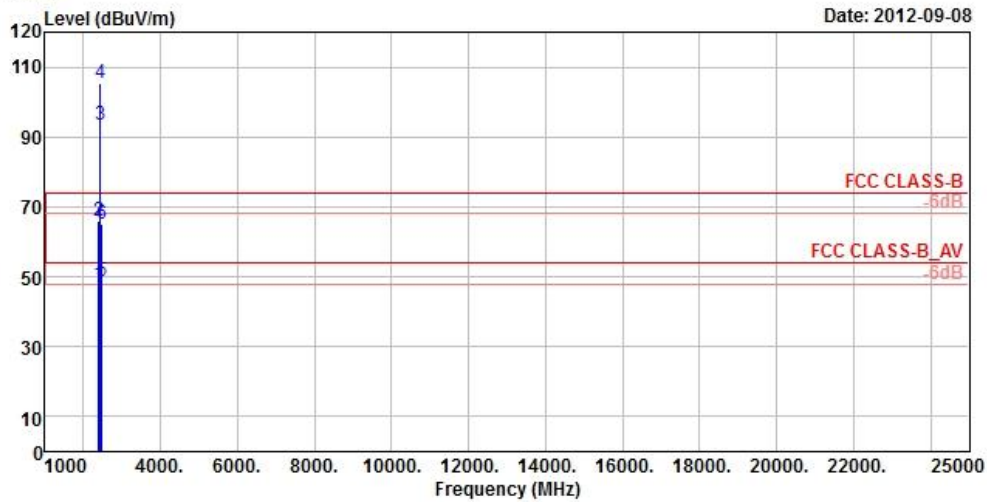

Site : 966 Chamber 5
 Condition : FCC CLASS-B 3m ANT_18G~40G_HF HORIZONTAL
 Brand/Model: XT901
 Remark : 11N_HT40 TX CH06
 Tested by : Kay Wu
 Temperature : 25°C
 Humidity : 65%
 Plane : X
 Rate : MCS0
 Power : 13

	Freq	Level	Read Level	Limit Line	OverAntenna Limit	Antenna Factor	Cable Loss	Preamp Factor	A/Pos	T/Pos	Remark
	MHz	dBuV/m	dBuV	dBuV/m	dB	dB/m	dB	dB	cm	deg	
1	2390.00	47.97	53.36	54.00	-6.03	27.26	4.87	37.52	127	118	Average
2	2390.00	66.07	71.46	74.00	-7.93	27.26	4.87	37.52	127	118	Peak
3	pp 2437.00	93.37	98.54			27.40	4.89	37.46	127	118	Average
4	pk 2437.00	105.46	110.63			27.40	4.89	37.46	127	118	Peak
5	! 2484.00	48.92	53.82	54.00	-5.08	27.50	4.92	37.32	127	118	Average
6	2484.00	65.18	70.08	74.00	-8.82	27.50	4.92	37.32	127	118	Peak



A D T



Bureau Veritas Consumer Products Services Ltd., Taoyuan Branch

A D T

Data: 20

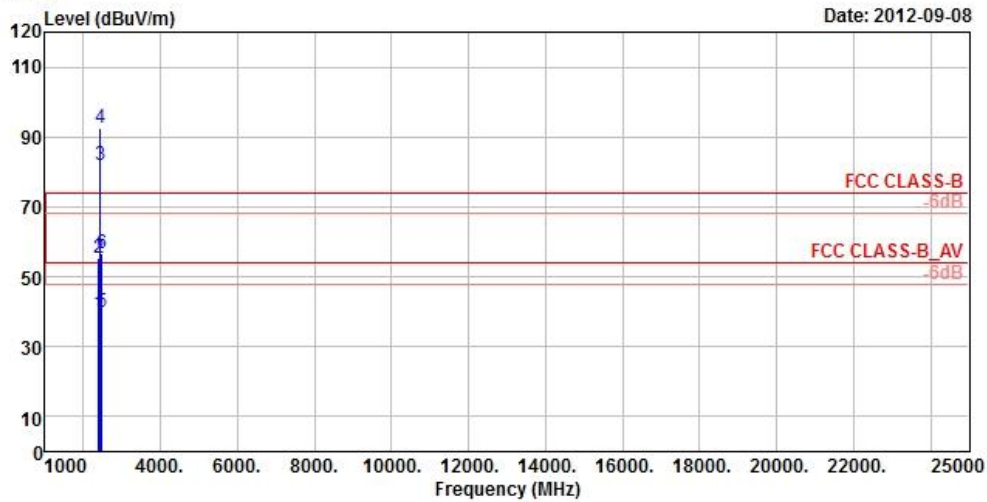

Site : 966 Chamber 5
 Condition : FCC CLASS-B 3m ANT_18G~40G_HF VERTICAL
 Brand/Model: XT901
 Remark : 11N_HT40 TX CH06
 Tested by : Kay Wu
 Temperature : 25°C
 Humidity : 65%
 Plane : X
 Rate : MCS0
 Power : 13

	Freq	Level	Read Level	Limit Line	OverAntenna Limit	Antenna Factor	Cable Loss	Preamp Factor	A/Pos	T/Pos	Remark
	MHz	dBuV/m	dBuV	dBuV/m	dB	dB/m	dB	dB	cm	deg	
1	2390.00	39.53	44.92	54.00	-14.47	27.26	4.87	37.52	100	360	Average
2	2390.00	55.32	60.71	74.00	-18.68	27.26	4.87	37.52	100	360	Peak
3 pp	2437.00	82.04	87.21			27.40	4.89	37.46	100	360	Average
4 pk	2437.00	92.69	97.86			27.40	4.89	37.46	100	360	Peak
5	2484.00	39.94	44.84	54.00	-14.06	27.50	4.92	37.32	100	360	Average
6	2484.00	56.80	61.70	74.00	-17.20	27.50	4.92	37.32	100	360	Peak



A D T



Bureau Veritas Consumer Products Services Ltd., Taoyuan Branch

A D T

Data: 19

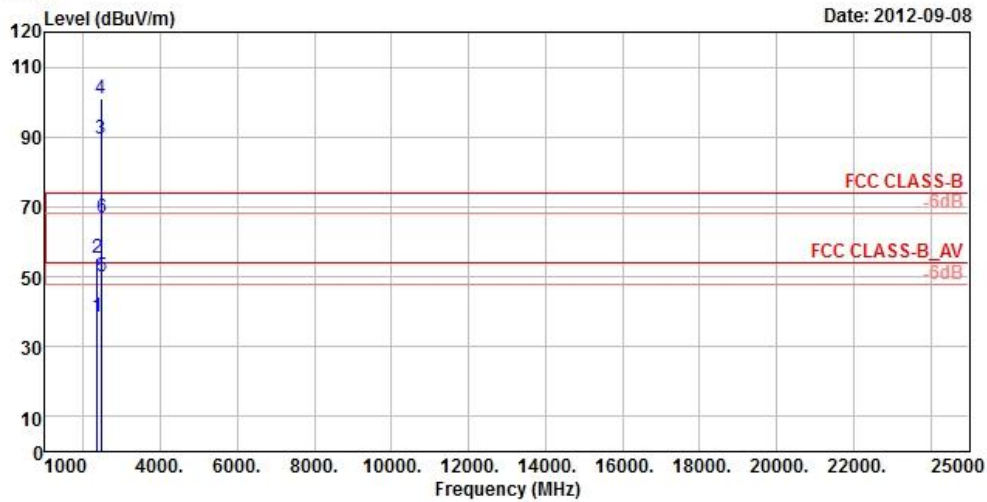

Site : 966 Chamber 5
 Condition : FCC CLASS-B 3m ANT_18G~40G_HF HORIZONTAL
 Brand/Model: XT901
 Remark : 11N_HT40 TX CH09
 Tested by : Kay Wu
 Temperature : 25°C
 Humidity : 65%
 Plane : X
 Rate : MCS0
 Power : 11

	Freq	Level	Read Level	Limit Line	OverAntenna Limit	Antenna Factor	Cable Loss	Preamp Factor	A/Pos	T/Pos	Remark
	MHz	dBuV/m	dBuV	dBuV/m	dB	dB/m	dB	dB	cm	deg	
1	2356.00	38.38	43.89	54.00	-15.62	27.16	4.82	37.49	100	128	Average
2	2356.00	55.42	60.93	74.00	-18.58	27.16	4.82	37.49	100	128	Peak
3 pp	2452.00	89.62	94.70			27.40	4.91	37.39	100	128	Average
4 pk	2452.00	100.86	105.94			27.40	4.91	37.39	100	128	Peak
5 !	2484.00	49.96	54.86	54.00	-4.04	27.50	4.92	37.32	100	128	Average
6	2484.00	66.66	71.56	74.00	-7.34	27.50	4.92	37.32	100	128	Peak



A D T



Bureau Veritas Consumer Products Services Ltd., Taoyuan Branch

A D T

Data: 20

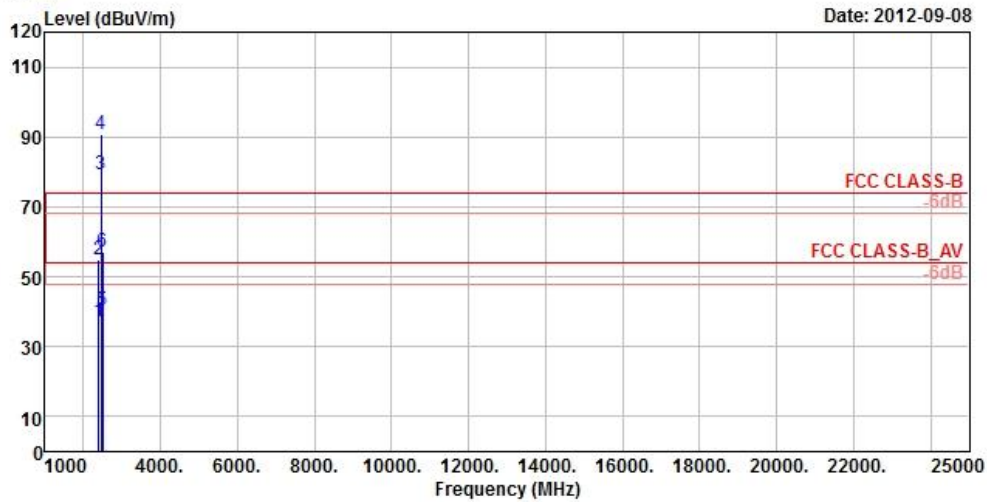

Site : 966 Chamber 5
 Condition : FCC CLASS-B 3m ANT_18G~40G_HF VERTICAL
 Brand/Model: XT901
 Remark : 11N_HT40 TX CH09
 Tested by : Kay Wu
 Temperature : 25°C
 Humidity : 65%
 Plane : X
 Rate : MCS0
 Power : 11

	Freq	Level	Read Level	Limit Line	OverAntenna Limit	Antenna Factor	Cable Loss	Preamp Factor	A/Pos	T/Pos	Remark
	MHz	dBuV/m	dBuV	dBuV/m	dB	dB/m	dB	dB	cm	deg	
1	2390.00	37.02	42.41	54.00	-16.98	27.26	4.87	37.52	100	0	Average
2	2390.00	54.78	60.17	74.00	-19.22	27.26	4.87	37.52	100	0	Peak
3 pp	2452.00	79.38	84.46			27.40	4.91	37.39	100	0	Average
4 pk	2452.00	90.61	95.69			27.40	4.91	37.39	100	0	Peak
5	2494.00	40.14	44.90	54.00	-13.86	27.55	4.94	37.25	100	0	Average
6	2494.00	57.06	61.82	74.00	-16.94	27.55	4.94	37.25	100	0	Peak



A D T

BELOW 1GHz WORST-CASE DATA : 802.11g



Bureau Veritas Consumer Products Services Ltd., Taoyuan Branch

A D T

Data: 5

Date: 2012-09-08

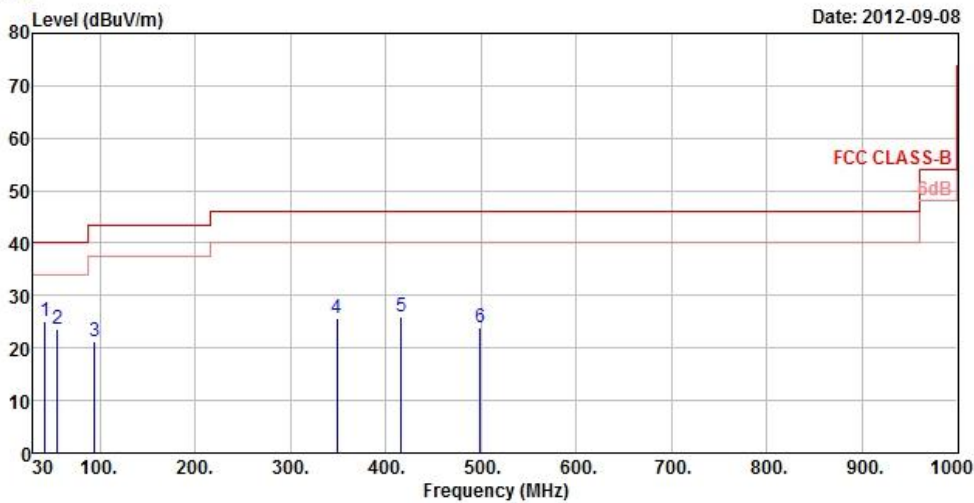

Site : 966 Chamber 5
 Condition : FCC CLASS-B 3m ANT_30M~1G_LF HORIZONTAL
 Brand/Model: XT901
 Remark : WIFI TX LF
 Tested by : Kay Wu
 Temperature : 25°C
 Humidity : 65%
 Plane : X

	Freq	Level	Read Level	Limit Line	OverLimit	Antenna Factor	Cable Loss	Preamp Factor	A/Pos	T/Pos	Remark
	MHz	dBUV/m	dBuV	dBUV/m	dB	dB/m	dB	dB	cm	deg	
1	pp	42.42	25.13	41.93	40.00	-14.87	13.58	0.70	31.08	222	144 Peak
2		55.11	23.48	41.56	40.00	-16.52	12.45	0.80	31.33	133	274 Peak
3		94.80	21.19	43.43	43.50	-22.31	8.68	1.04	31.96	123	32 Peak
4		349.00	25.61	41.11	46.00	-20.39	14.12	2.22	31.84	120	285 Peak
5		416.20	25.88	39.76	46.00	-20.12	15.66	2.49	32.03	100	57 Peak
6		499.50	24.05	35.59	46.00	-21.95	17.31	2.78	31.63	124	241 Peak



A D T



Bureau Veritas Consumer Products Services Ltd., Taoyuan Branch

A D T

Data: 6

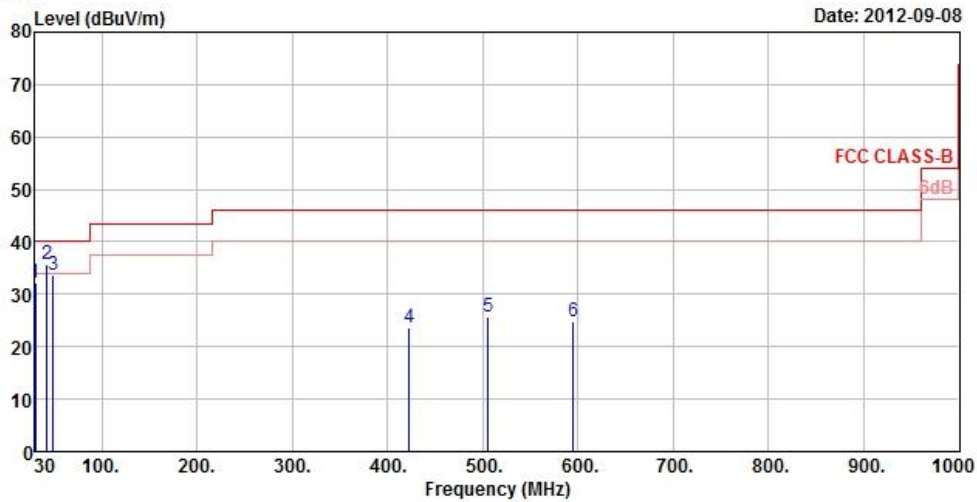

Site : 966 Chamber 5
 Condition : FCC CLASS-B 3m ANT_30M~1G_LF VERTICAL
 Brand/Model: XT901
 Remark : WIFI TX LF
 Tested by : Kay Wu
 Temperature : 25°C
 Humidity : 65%
 Plane : X

	Freq	Level	Read Level	Limit Line	OverLimit	Antenna Factor	Cable Loss	Preamp Factor	A/Pos	T/Pos	Remark
	MHz	dBuV/m	dBuV	dBuV/m	dB	dB/m	dB	dB	cm	deg	
1 qp	30.00	32.04	50.63	40.00	-7.96	11.98	0.57	31.14	100	159	QP
2 pp	42.15	35.65	52.45	40.00	-4.35	13.58	0.70	31.08	133	22	Peak
3	48.90	33.77	51.08	40.00	-6.23	13.18	0.76	31.25	133	247	Peak
4	422.50	23.67	37.41	46.00	-22.33	15.79	2.51	32.04	122	277	Peak
5	505.80	25.75	37.09	46.00	-20.25	17.46	2.80	31.60	189	57	Peak
6	595.40	24.89	34.52	46.00	-21.11	19.50	3.07	32.20	158	37	Peak

4.2 CONDUCTED EMISSION MEASUREMENT

4.2.1 LIMITS OF CONDUCTED EMISSION MEASUREMENT

FREQUENCY OF EMISSION (MHz)	CONDUCTED LIMIT (dB μ V)	
	Quasi-peak	Average
0.15 ~ 0.5	66 to 56	56 to 46
0.5 ~ 5	56	46
5 ~ 30	60	50

- NOTE:** 1. The lower limit shall apply at the transition frequencies.
2. The limit decreases in line with the logarithm of the frequency in the range of 0.15 to 0.50MHz.
3. All emanations from a class A/B digital device or system, including any network of conductors and apparatus connected thereto, shall not exceed the level of field strengths specified above.

4.2.2 TEST INSTRUMENTS

DESCRIPTION & MANUFACTURER	MODEL NO.	SERIAL NO.	DATE OF CALIBRATION	DUE DATE OF CALIBRATION
Test Receiver ROHDE & SCHWARZ	ESCS30	100289	Nov. 19, 2011	Nov. 18, 2012
RF signal cable Woken	5D-FB	Cable-HYCO2-01	Dec. 29, 2011	Dec. 28, 2012
LISN ROHDE & SCHWARZ (EUT)	ESH2-Z5	100100	Dec. 30, 2011	Dec. 29, 2012
LISN ROHDE & SCHWARZ (Peripheral)	ESH3-Z5	100311	Jul. 06, 2012	Jul. 05, 2013
Software ADT	BV ADT_Cond_ V7.3.7.3	NA	NA	NA

- NOTE:** 1. The calibration interval of the above test instruments is 12 months and the calibrations are traceable to NML/ROC and NIST/USA.
2. The test was performed in HwaYa Shielded Room 2.
3. The VCCI Site Registration No. is C-2047.

4.2.3 TEST PROCEDURES

- a. The EUT was placed 0.4 meters from the conducting wall of the shielded room with EUT being connected to the power mains through a line impedance stabilization network (LISN). Other support units were connected to the power mains through another LISN. The two LISNs provide 50 ohm/ 50uH of coupling impedance for the measuring instrument.
- b. Both lines of the power mains connected to the EUT were checked for maximum conducted interference.
- c. The frequency range from 150kHz to 30MHz was searched. Emission levels under (Limit - 20dB) was not recorded.

NOTE: All modes of operation were investigated and the worst-case emissions are reported.

4.2.4 DEVIATION FROM TEST STANDARD

No deviation.

4.2.5 TEST SETUP

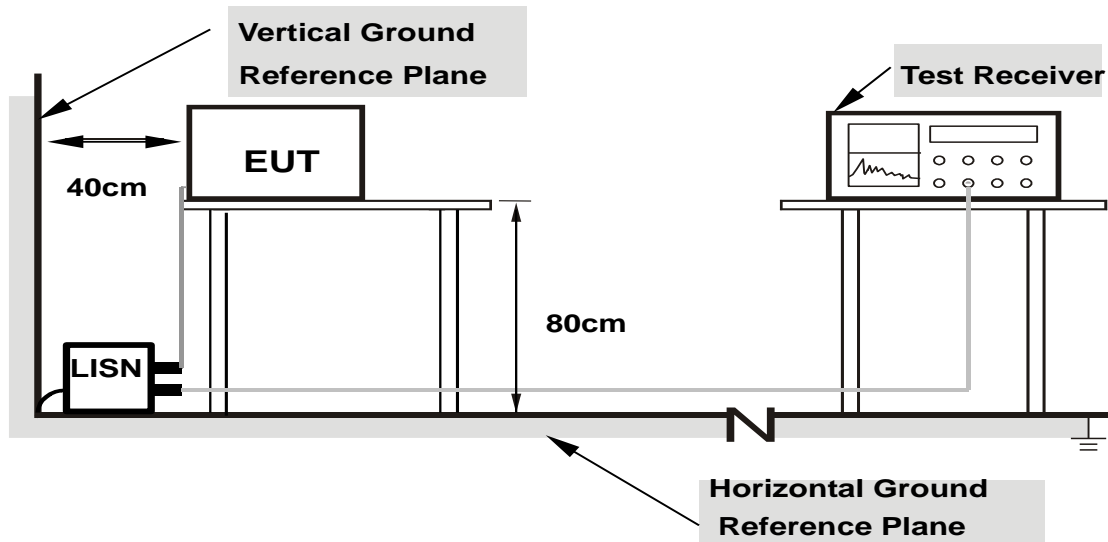

- Note:**
1. Support units were connected to second LISN.
 2. Both of LISNs (AMN) are 80 cm from EUT and at least 80 from other units and other metal planes

For the actual test configuration, please refer to the attached file (Test Setup Photo).

4.2.6 EUT OPERATING CONDITIONS

Same as 4.1.6.

4.2.7 TEST RESULTS

CONDUCTED WORST-CASE DATA : 802.11g

PHASE	Line 1	6dB BANDWIDTH	9kHz
-------	--------	---------------	------

No	Freq. [MHz]	Corr. Factor (dB)	Reading Value [dB (uV)]		Emission Level [dB (uV)]		Limit [dB (uV)]		Margin (dB)	
			Q.P.	AV.	Q.P.	AV.	Q.P.	AV.	Q.P.	AV.
			1	0.21641	0.15	34.39	17.35	34.54	17.50	62.96
2	0.48984	0.17	37.00	23.80	37.17	23.97	56.17	46.17	-19.00	-22.20
3	0.84531	0.18	37.55	24.08	37.73	24.26	56.00	46.00	-18.27	-21.74
4	3.89844	0.34	43.02	32.45	43.36	32.79	56.00	46.00	-12.64	-13.21
5	10.28125	0.44	39.07	29.90	39.51	30.34	60.00	50.00	-20.49	-19.66
6	29.05078	0.52	40.04	28.46	40.56	28.98	60.00	50.00	-19.44	-21.02

REMARKS:

1. Q.P. and AV. are abbreviations of quasi-peak and average individually.
2. The emission levels of other frequencies were very low against the limit.
3. Margin value = Emission level - Limit value
4. Correction factor = Insertion loss + Cable loss
5. Emission Level = Correction Factor + Reading Value.

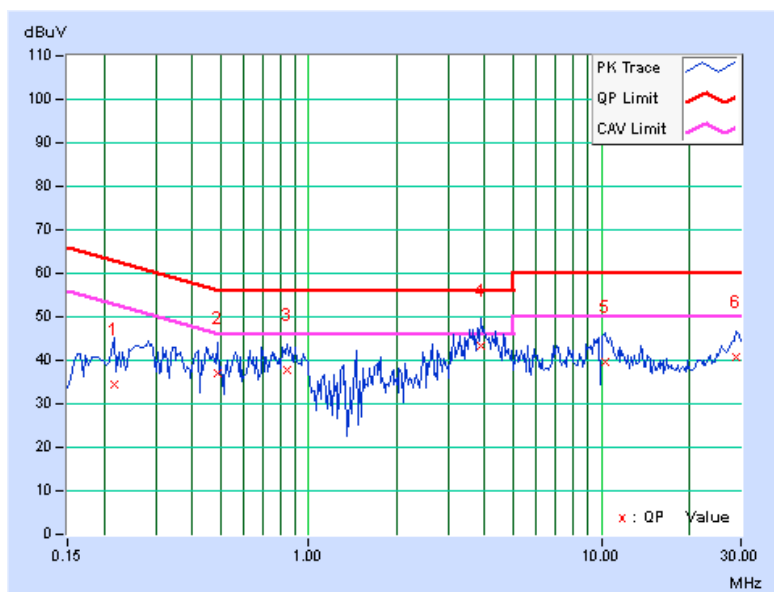



A D T

PHASE	Line 2	6dB BANDWIDTH	9kHz
-------	--------	---------------	------

No	Freq. [MHz]	Corr. Factor (dB)	Reading Value [dB (uV)]		Emission Level [dB (uV)]		Limit [dB (uV)]		Margin (dB)	
			Q.P.	AV.	Q.P.	AV.	Q.P.	AV.	Q.P.	AV.
			1	0.26719	0.15	39.53	26.60	39.68	26.75	61.20
2	0.50000	0.17	36.88	23.33	37.05	23.50	56.00	46.00	-18.95	-22.50
3	0.91563	0.19	35.94	19.89	36.13	20.08	56.00	46.00	-19.87	-25.92
4	3.48438	0.33	40.55	29.26	40.88	29.59	56.00	46.00	-15.12	-16.41
5	9.50391	0.47	37.44	27.41	37.91	27.88	60.00	50.00	-22.09	-22.12
6	29.54297	0.54	40.09	28.25	40.63	28.79	60.00	50.00	-19.37	-21.21

REMARKS:

1. Q.P. and AV. are abbreviations of quasi-peak and average individually.
2. The emission levels of other frequencies were very low against the limit.
3. Margin value = Emission level - Limit value
4. Correction factor = Insertion loss + Cable loss
5. Emission Level = Correction Factor + Reading Value.

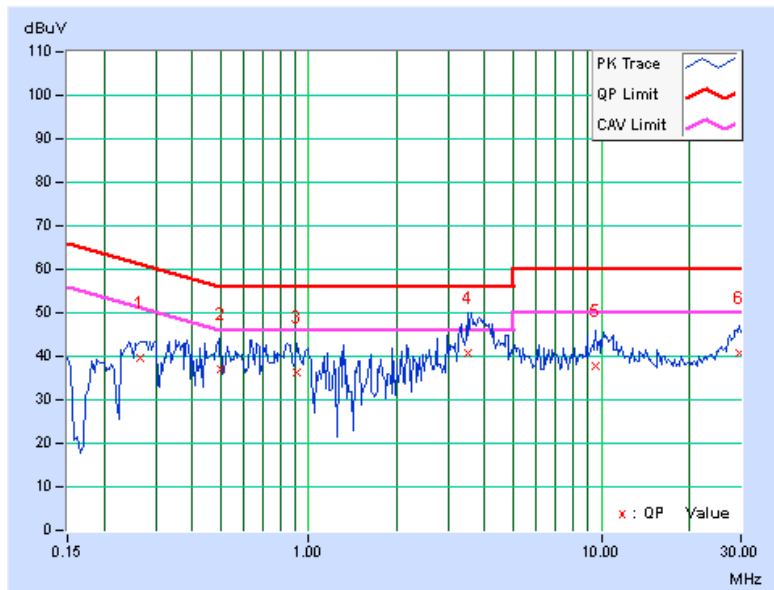

4.3 6dB BANDWIDTH MEASUREMENT

4.3.1 LIMITS OF 6dB BANDWIDTH MEASUREMENT

The minimum of 6dB Bandwidth Measurement is 0.5 MHz.

4.3.2 TEST SETUP

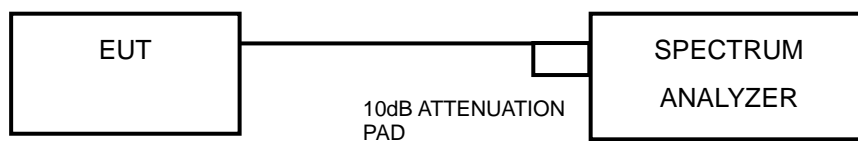

4.3.3 TEST INSTRUMENTS

Refer to section 4.1.2 to get information of above instrument.

4.3.4 TEST PROCEDURE

- a. Set resolution bandwidth (RBW) = approximately 1% of the emission bandwidth
- b. Set the video bandwidth (VBW) $\geq 3 \times$ RBW, Detector = Peak.
- c. Trace mode = max hold.
- d. Sweep = auto couple.
- e. Measure the maximum width of the emission that is constrained by the frequencies associated with the two amplitude points (upper and lower) that are attenuated by 6 dB relative to the maximum level measured in the fundamental emission

4.3.5 DEVIATION FROM TEST STANDARD

No deviation.

4.3.6 EUT OPERATING CONDITIONS

The software provided by client to enable the EUT under transmission condition continuously at lowest, middle and highest channel frequencies individually.



A D T

4.3.7 TEST RESULTS

802.11b

CHANNEL	FREQUENCY (MHz)	6dB BANDWIDTH (MHz)	MINIMUM LIMIT (MHz)	PASS / FAIL
1	2412	8.61	0.5	PASS
6	2437	9.2	0.5	PASS
11	2462	8.11	0.5	PASS

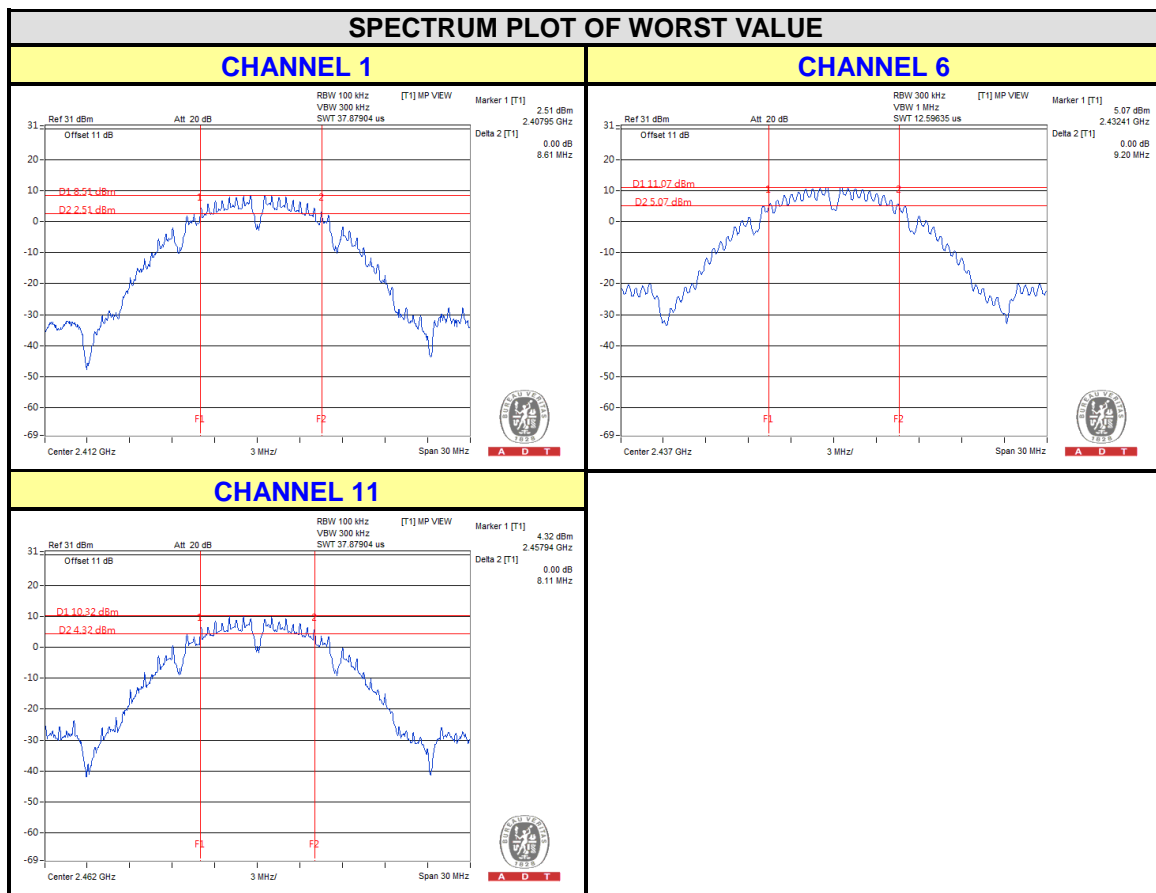



A D T

802.11g

CHANNEL	FREQUENCY (MHz)	6dB BANDWIDTH (MHz)	MINIMUM LIMIT (MHz)	PASS / FAIL
1	2412	16.5	0.5	PASS
6	2437	16.51	0.5	PASS
11	2462	16.53	0.5	PASS

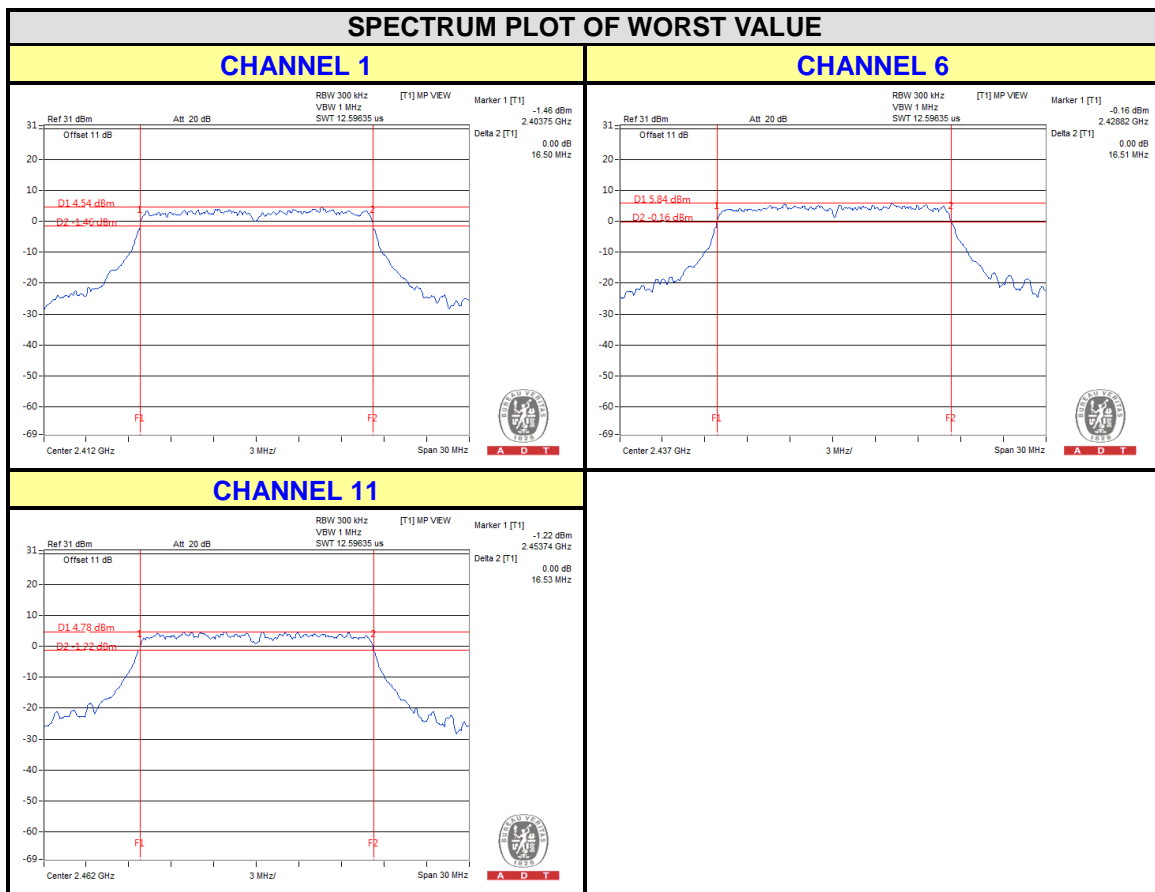



A D T

802.11n (20MHz)

CHANNEL	FREQUENCY (MHz)	6dB BANDWIDTH (MHz)	MINIMUM LIMIT (MHz)	PASS / FAIL
1	2412	17.8	0.5	PASS
6	2437	17.73	0.5	PASS
11	2462	17.78	0.5	PASS

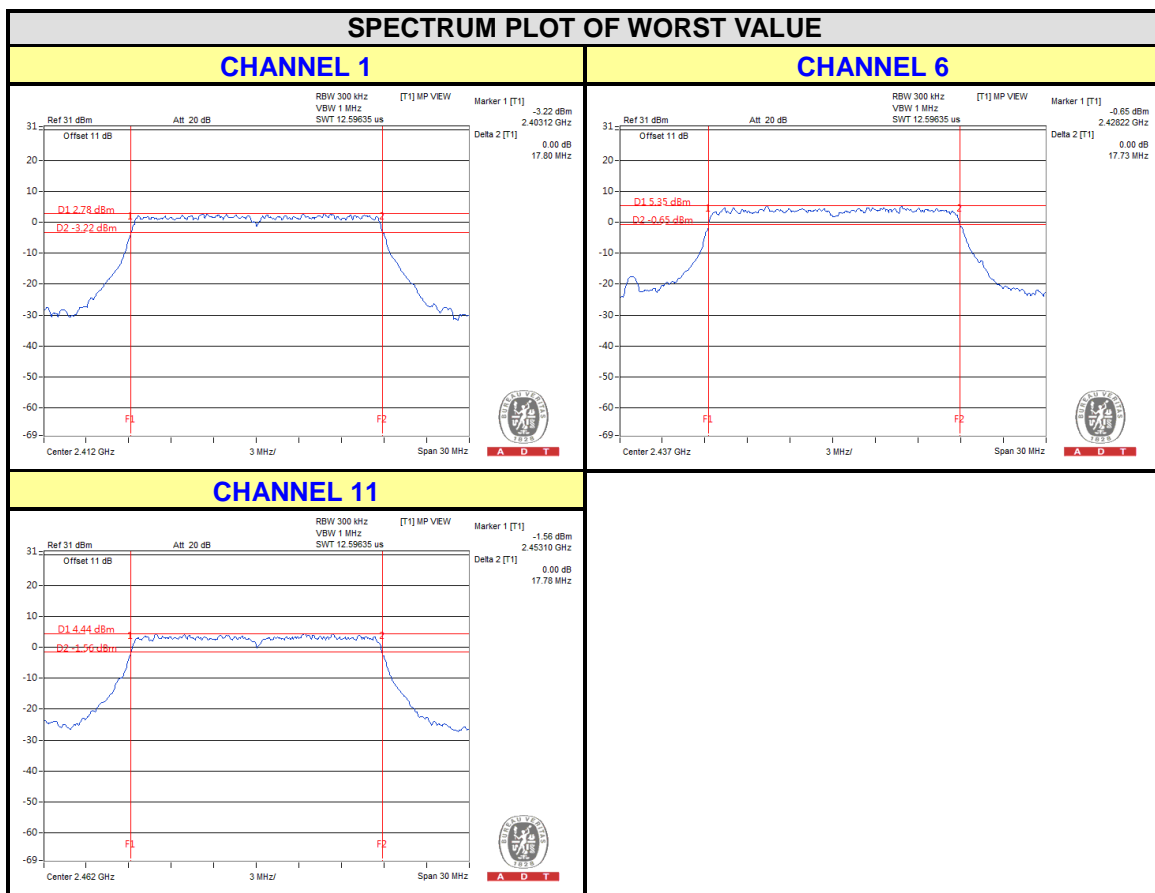



A D T

802.11n (40MHz)

CHANNEL	FREQUENCY (MHz)	6dB BANDWIDTH (MHz)	MINIMUM LIMIT (MHz)	PASS / FAIL
3	2422	36.06	0.5	PASS
6	2437	36.14	0.5	PASS
9	2452	36.13	0.5	PASS

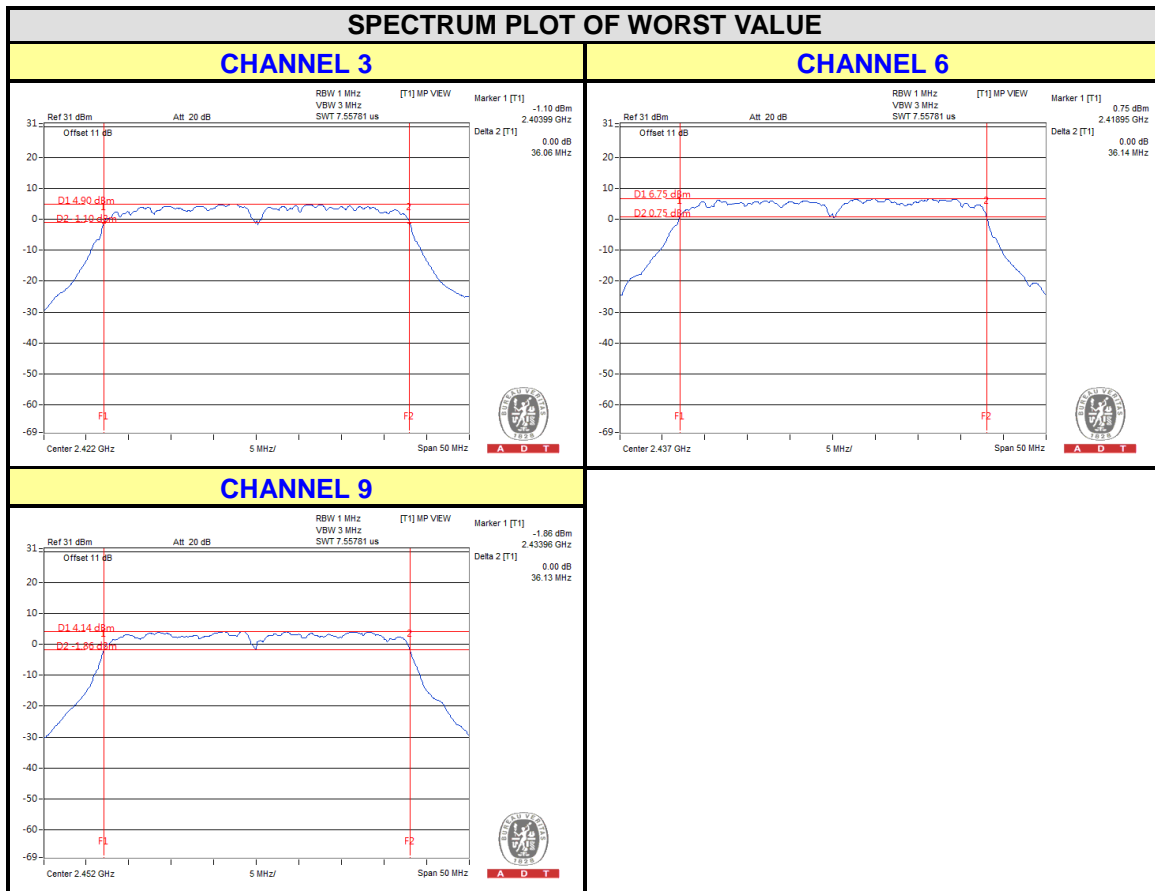

4.4 CONDUCTED OUTPUT POWER

4.4.1 LIMITS OF CONDUCTED OUTPUT POWER MEASUREMENT

For systems using digital modulation in the 2400–2483.5 MHz bands: 1 Watt (30dBm)

4.4.2 TEST SETUP

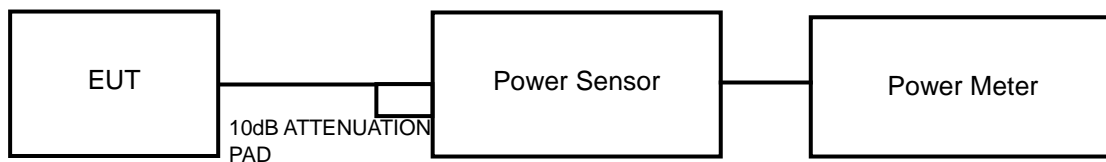

4.4.3 TEST INSTRUMENTS

Refer to section 4.1.2 to get information of above instrument.

4.4.4 TEST PROCEDURES

A peak power sensor was used on the output port of the EUT. A power meter was used to read the response of the peak power sensor. Record the peak power level.

4.4.5 DEVIATION FROM TEST STANDARD

No deviation.

4.4.6 EUT OPERATING CONDITIONS

Same as Item 4.3.6.



4.4.7 TEST RESULTS

Power Setting

Mode	CHANNEL	FREQUENCY (MHz)	Power Setting
802.11b	1	2412	16
	6	2437	18
	11	2462	17
802.11g	1	2412	13
	6	2437	14
	11	2462	13
802.11n (20MHz)	1	2412	12
	6	2437	14
	11	2462	13
802.11n (40MHz)	3	2422	12
	6	2437	13
	9	2452	11

Note: Power Cutbacks are required to pass band edge test on channel 1 and channel 11.

**802.11b**

CHANNEL	FREQUENCY (MHz)	PEAK POWER (mW)	PEAK POWER (dBm)	LIMIT (dBm)	PASS/FAIL
1	2412	94.189	19.74	30	PASS
6	2437	151.356	21.8	30	PASS
11	2462	139.959	21.46	30	PASS

802.11g

CHANNEL	FREQUENCY (MHz)	PEAK POWER (mW)	PEAK POWER (dBm)	LIMIT (dBm)	PASS/FAIL
1	2412	145.881	21.64	30	PASS
6	2437	165.577	22.19	30	PASS
11	2462	161.808	22.09	30	PASS

802.11n (20MHz)

CHANNEL	FREQUENCY (MHz)	PEAK POWER (mW)	PEAK POWER (dBm)	LIMIT (dBm)	PASS/FAIL
1	2412	120.504	20.81	30	PASS
6	2437	154.525	21.89	30	PASS
11	2462	148.252	21.71	30	PASS

802.11n (40MHz)

CHANNEL	FREQUENCY (MHz)	PEAK POWER (mW)	PEAK POWER (dBm)	LIMIT (dBm)	PASS/FAIL
3	2422	112.460	20.51	30	PASS
6	2437	139.316	21.44	30	PASS
9	2452	114.815	20.6	30	PASS

4.5 POWER SPECTRAL DENSITY MEASUREMENT

4.5.1 LIMITS OF POWER SPECTRAL DENSITY MEASUREMENT

The Maximum of Power Spectral Density Measurement is 8dBm.

4.5.2 TEST SETUP

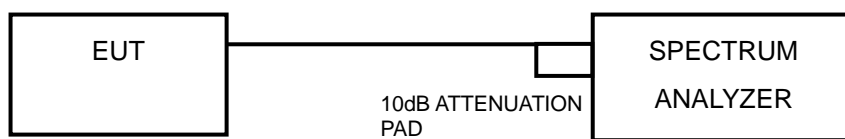

4.5.3 TEST INSTRUMENTS

Refer to section 4.1.2 to get information of above instrument.

4.5.4 TEST PROCEDURE

- a. Set the RBW = 100 kHz, VBW = 300 kHz, Detector = peak.
- b. Sweep time = auto couple, Trace mode = max hold, allow trace to fully stabilize.
- c. Use the peak marker function to determine the maximum power level in any 100 kHz band segment within the fundamental EBW.
- d. Scale the observed power level to an equivalent value in 3 kHz by adjusting (reducing) the measured power by a bandwidth correction factor (BWCF) where $BWCF = 10\log(3 \text{ kHz}/100\text{kHz})$

4.5.5 DEVIATION FROM TEST STANDARD

No deviation.

4.5.6 EUT OPERATING CONDITION

Same as Item 4.3.6



A D T

4.5.7 TEST RESULTS

802.11b

Channel	FREQ. (MHz)	PSD (dBm/100kHz)	PSD (dBm/3kHz)	Limit (dBm/3kHz)	PASS /FAIL
1	2412	8.59	-6.61	8	PASS
6	2437	10.72	-4.48	8	PASS
11	2462	10.25	-4.95	8	PASS

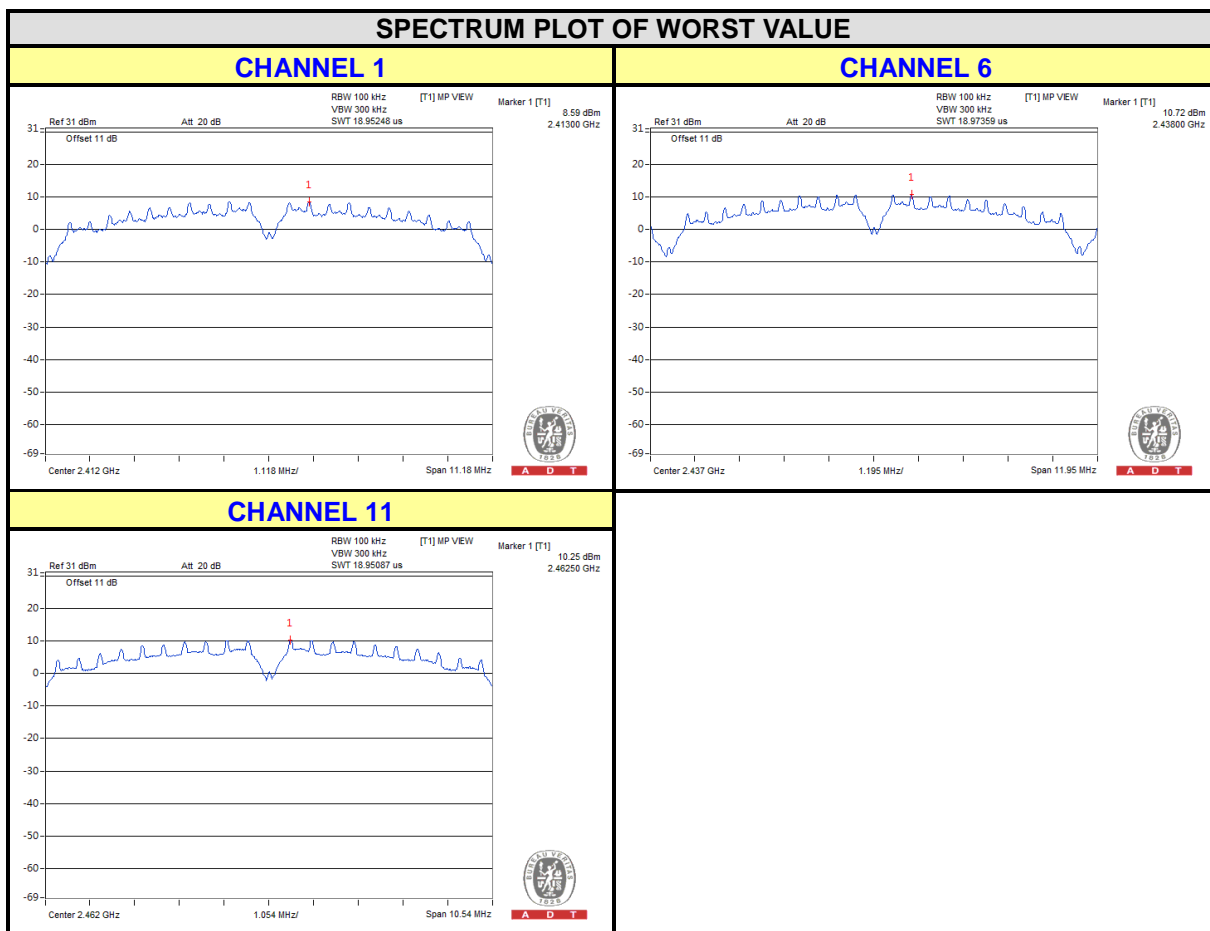



A D T

802.11g

Channel	FREQ. (MHz)	PSD (dBm/100kHz)	PSD (dBm/3kHz)	Limit (dBm/3kHz)	PASS /FAIL
1	2412	1.76	-13.44	8	PASS
6	2437	2.96	-12.24	8	PASS
11	2462	2.53	-12.67	8	PASS

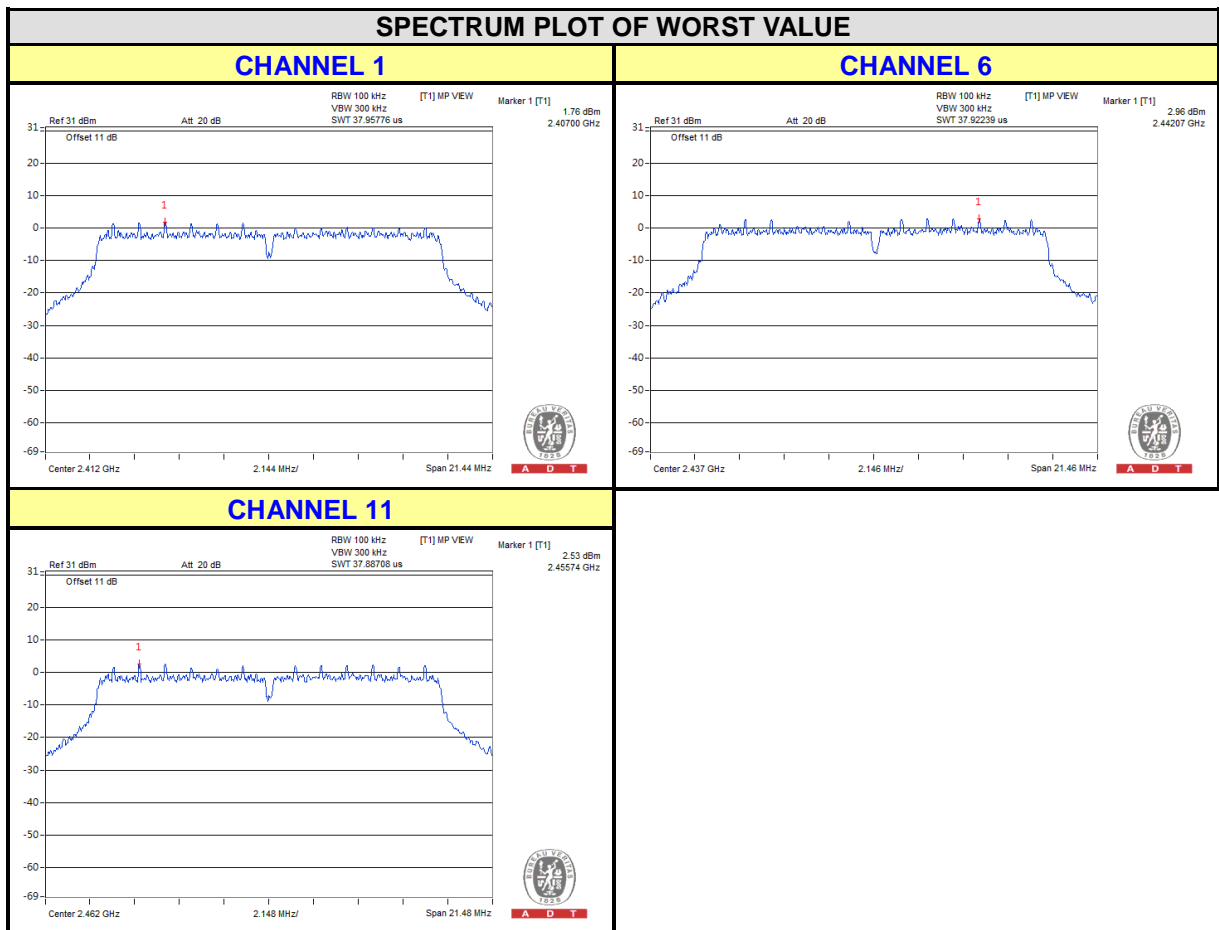



A D T

802.11n (20MHz)

Channel	FREQ. (MHz)	PSD (dBm/100kHz)	PSD (dBm/3kHz)	Limit (dBm/3kHz)	PASS /FAIL
1	2412	1.12	-14.08	8	PASS
6	2437	2.38	-12.82	8	PASS
11	2462	2.49	-12.71	8	PASS

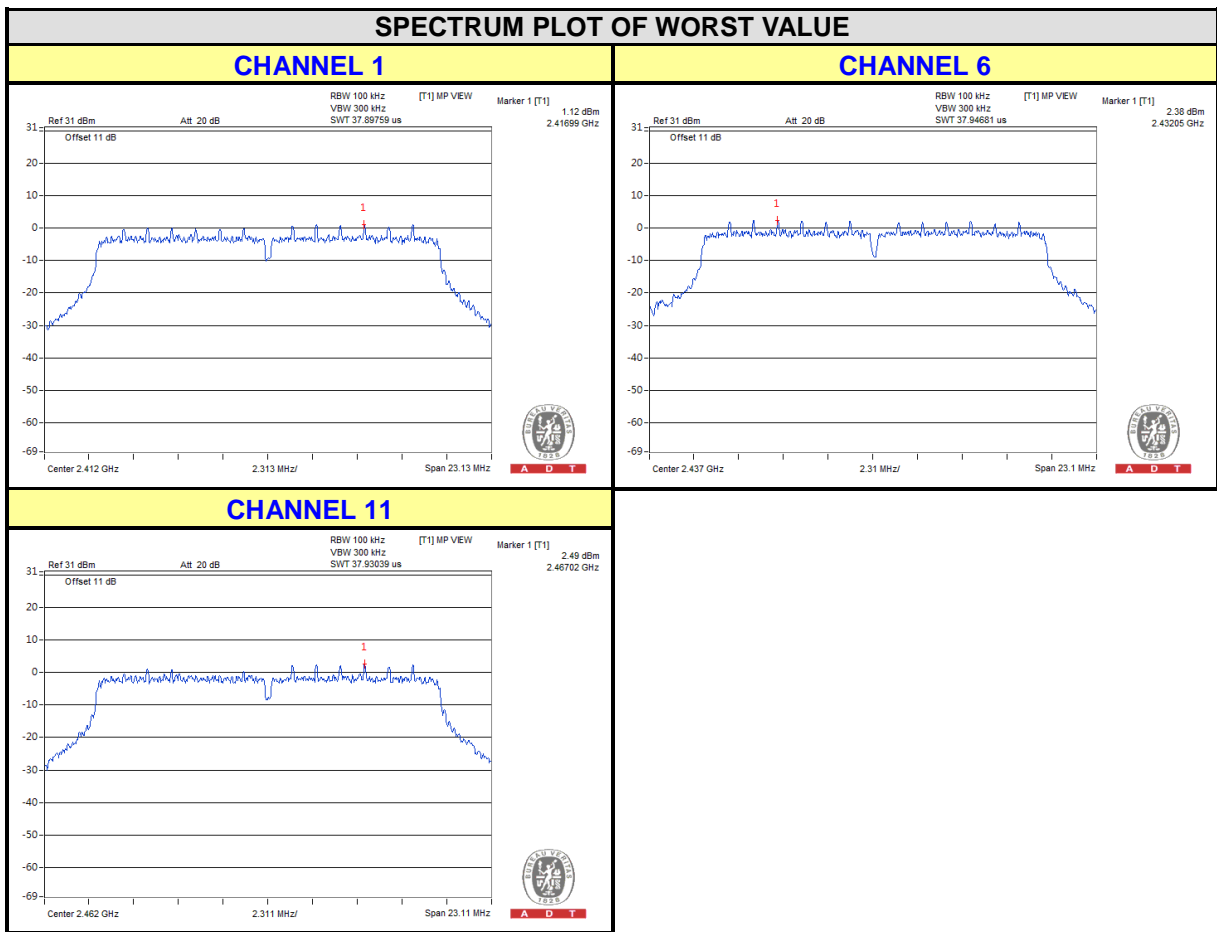



A D T

802.11n (40MHz)

Channel	FREQ. (MHz)	PSD (dBm/100kHz)	PSD (dBm/3kHz)	Limit (dBm/3kHz)	PASS /FAIL
3	2422	-2.73	-17.93	8	PASS
6	2437	-1.16	-16.36	8	PASS
9	2452	-3.63	-18.83	8	PASS

SPECTRUM PLOT OF WORST VALUE

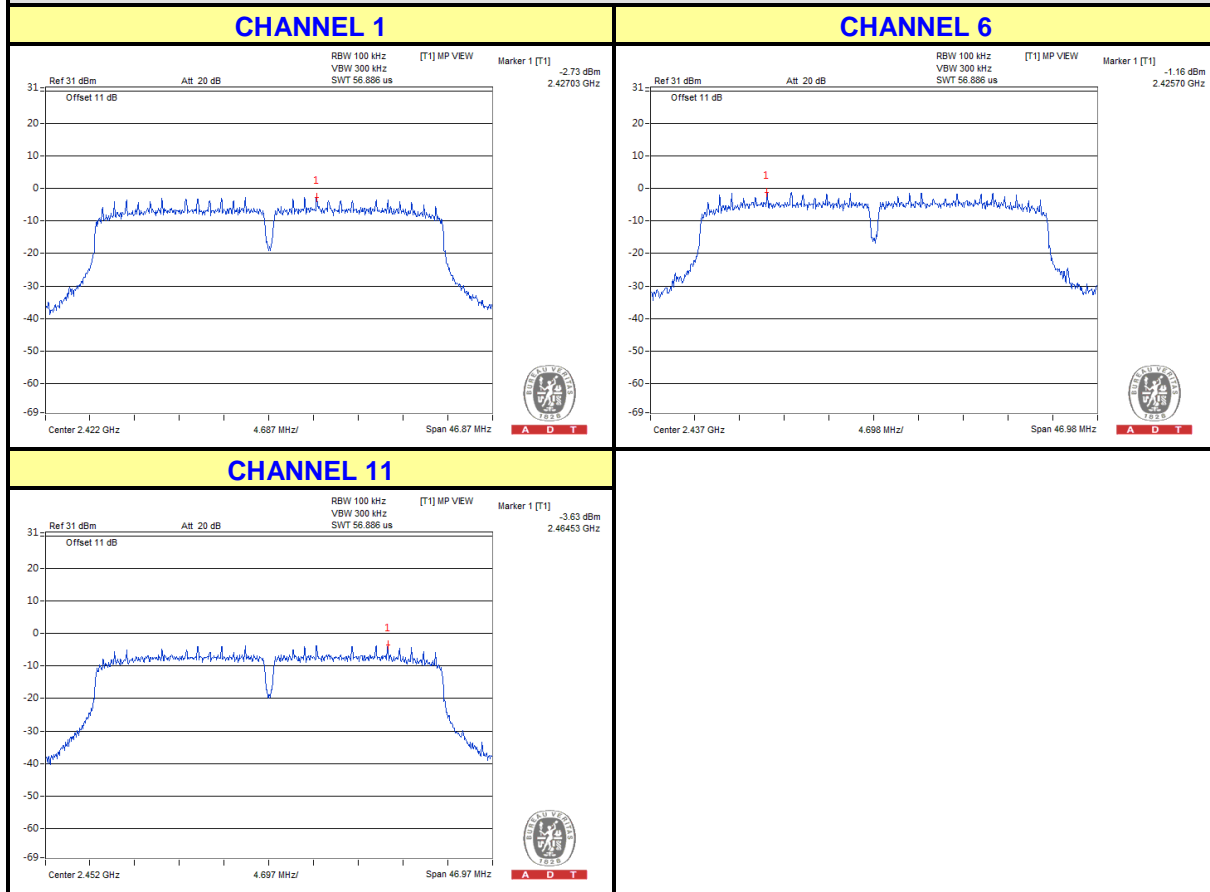

4.6 CONDUCTED OUT OF BAND EMISSION MEASUREMENT

4.6.1 LIMITS OF CONDUCTED OUT OF BAND EMISSION MEASUREMENT

Below -20dB of the highest emission level of operating band (in 100kHz Resolution Bandwidth).

4.6.2 TEST SETUP

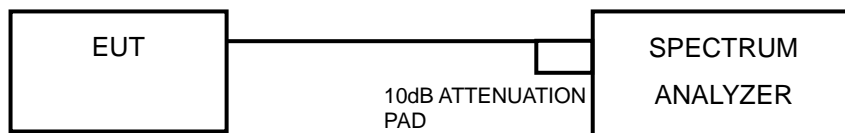

4.6.3 TEST INSTRUMENTS

Refer to section 4.1.2 to get information of above instrument.

4.6.4 TEST PROCEDURE

MEASUREMENT PROCEDURE REF

1. Set the RBW = 100 kHz.
2. Set the VBW \geq 300 kHz.
3. Detector = peak.
4. Sweep time = auto couple.
5. Trace mode = max hold.
6. Allow trace to fully stabilize.
7. Use the peak marker function to determine the maximum power level in any 100 kHz band segment within the fundamental EBW.

MEASUREMENT PROCEDURE OOB

1. Set RBW = 100 kHz.
2. Set VBW \geq 300 kHz.
3. Set span to encompass the spectrum to be examined.
4. Detector = peak.
5. Trace Mode = max hold.
6. Sweep = auto couple.

4.6.5 DEVIATION FROM TEST STANDARD

No deviation.

4.6.6 EUT OPERATING CONDITION

Same as Item 4.3.6

4.6.7 TEST RESULTS

The spectrum plots are attached on the following pages. D1 line indicates the highest level, and D2 line indicates the 20dB offset below D1. It shows compliance with the requirement.



A D T

802.11b

CH 1

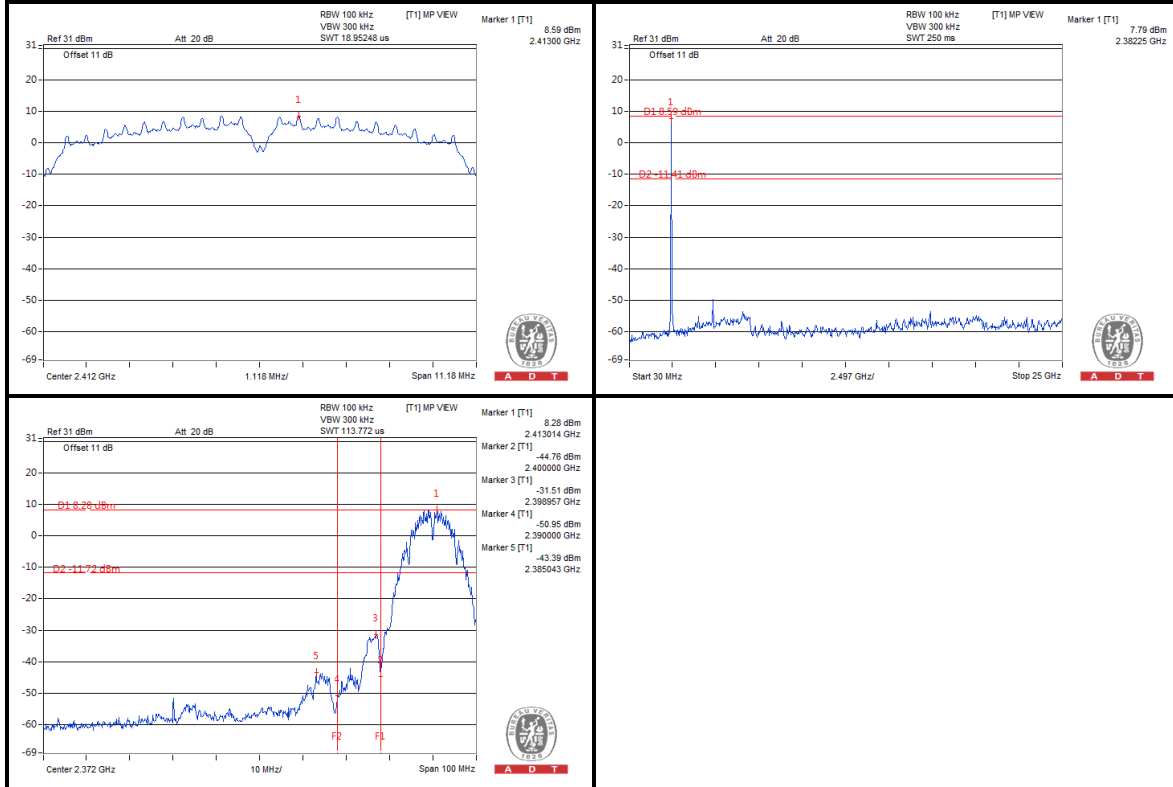

CH 6

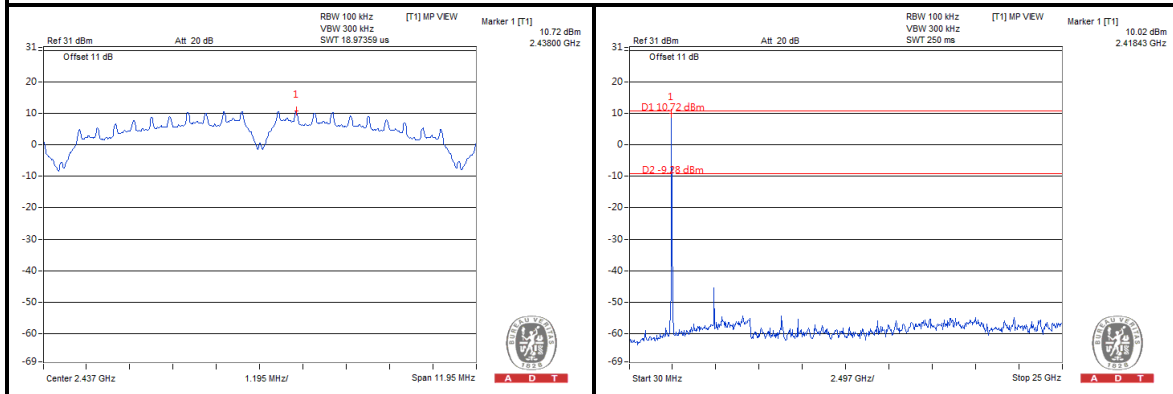



A D T

CH 11

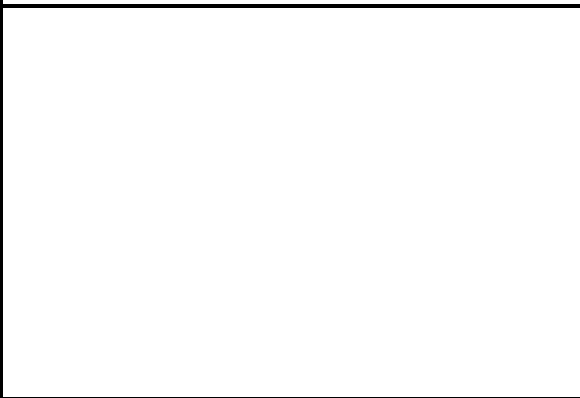
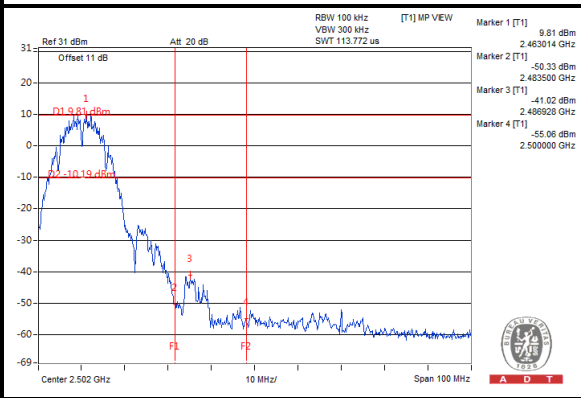
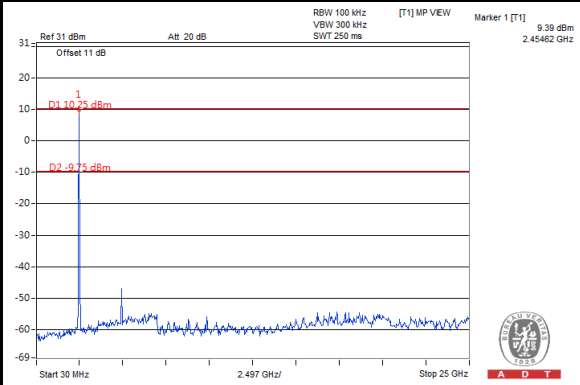
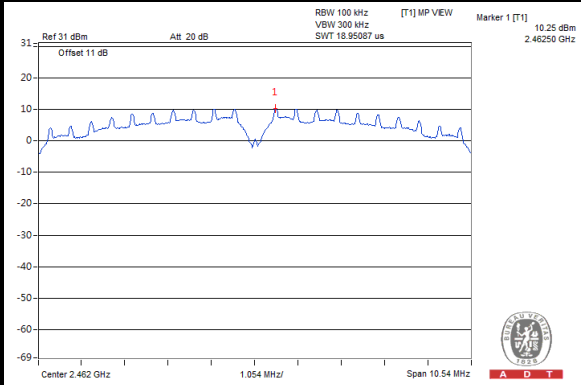



A D T

802.11g

CH 1

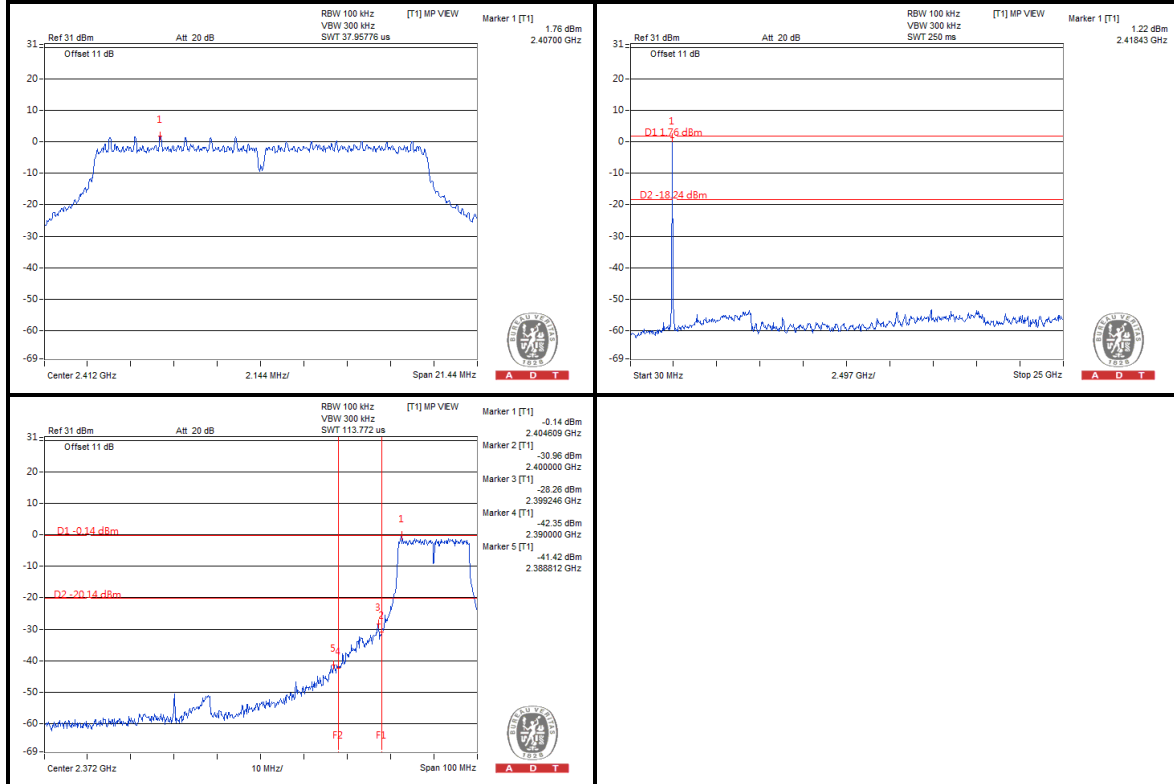

CH 6

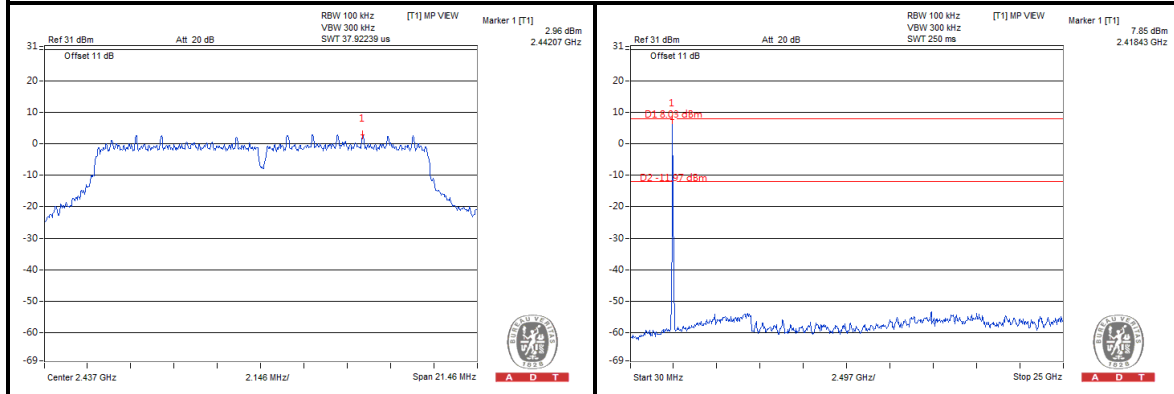



A D T

CH 11

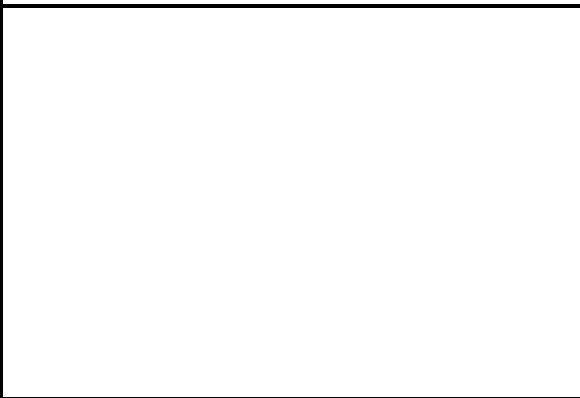
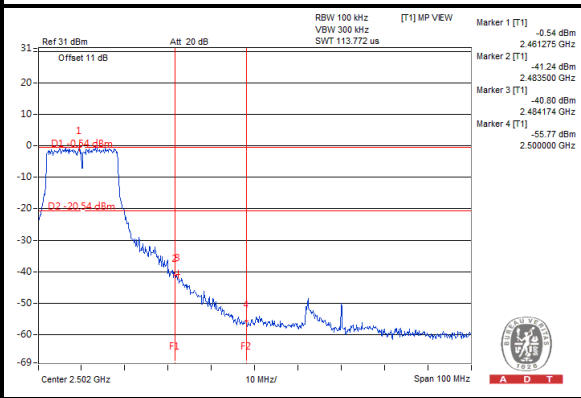
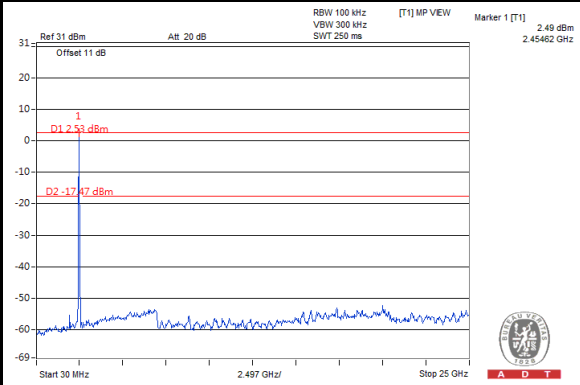
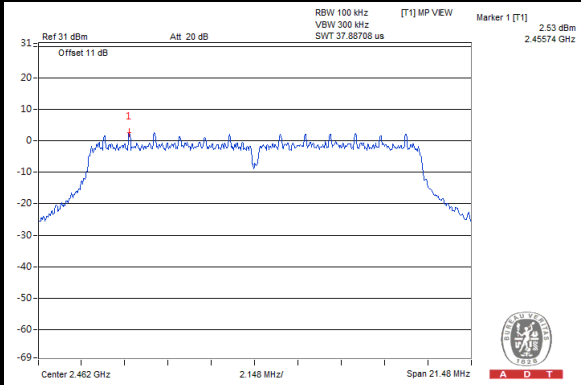



A D T

802.11n (20MHz)

CH 1

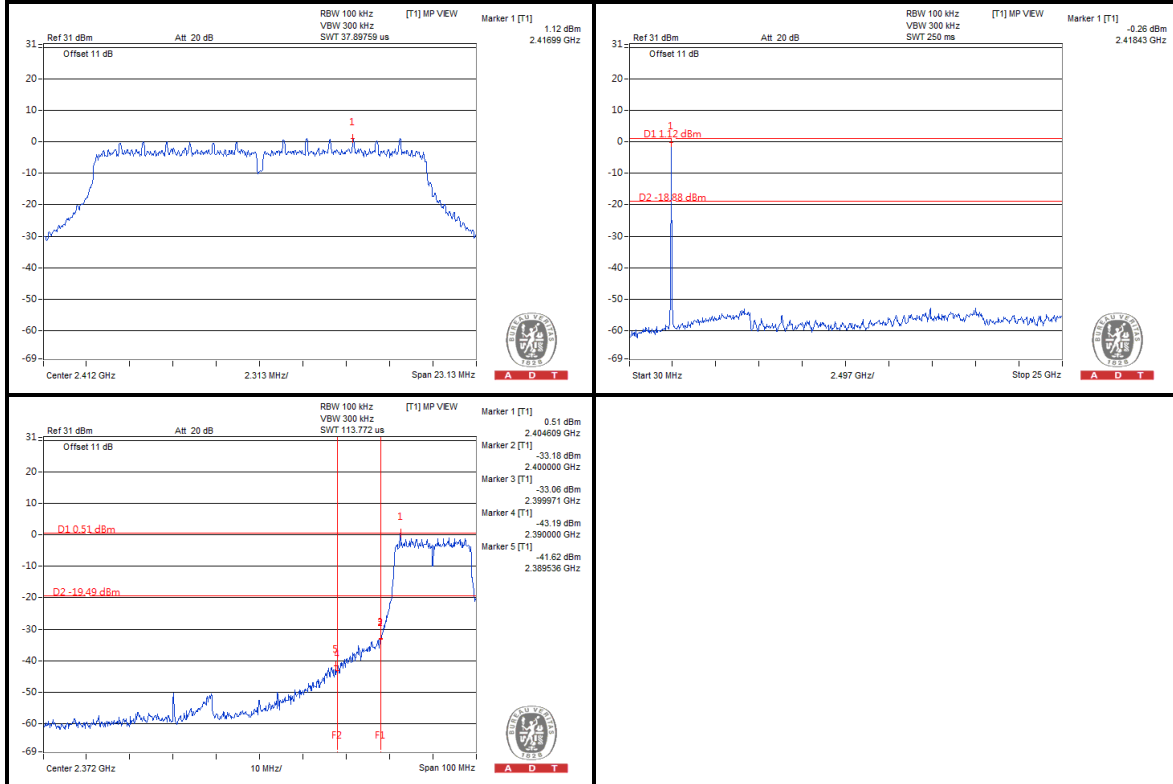

CH 6

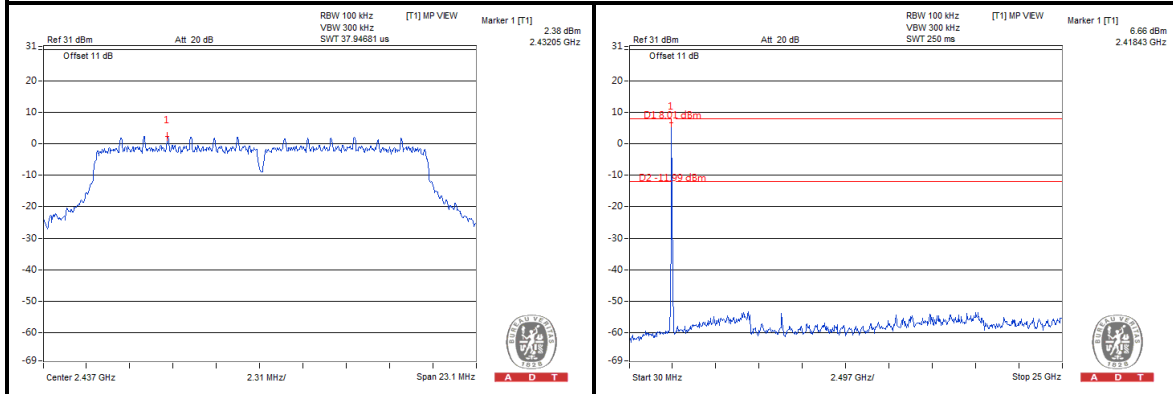



A D T

CH 11

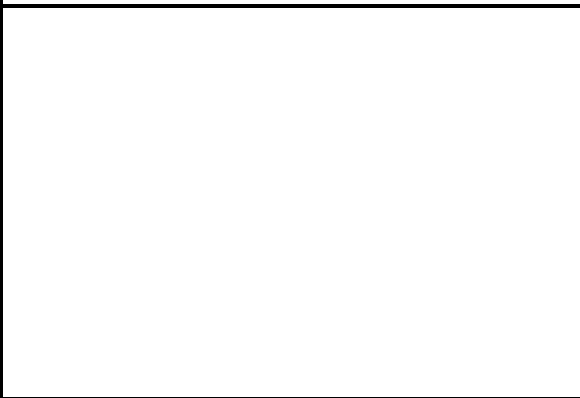
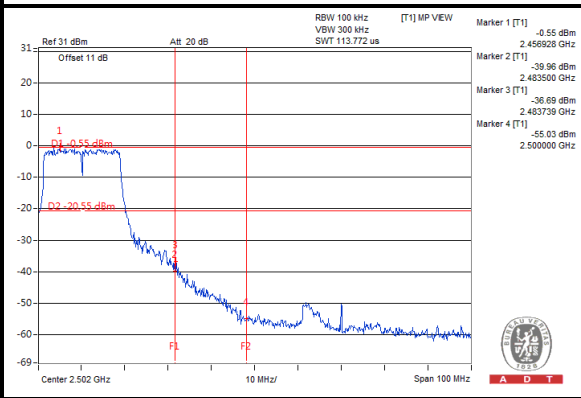
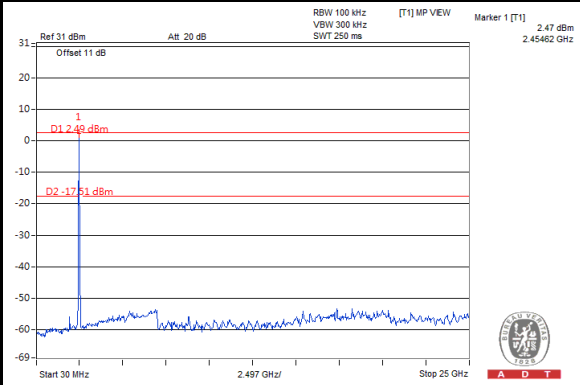
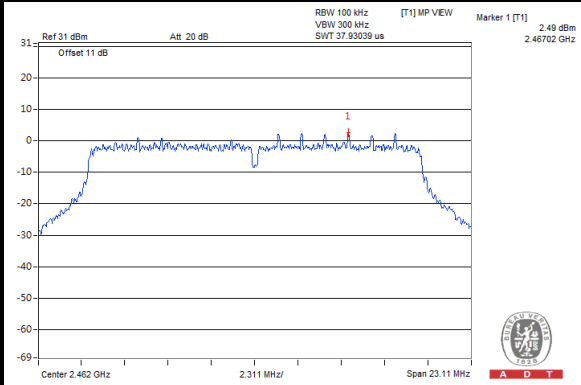



A D T

802.11n (40MHz)

CH 1

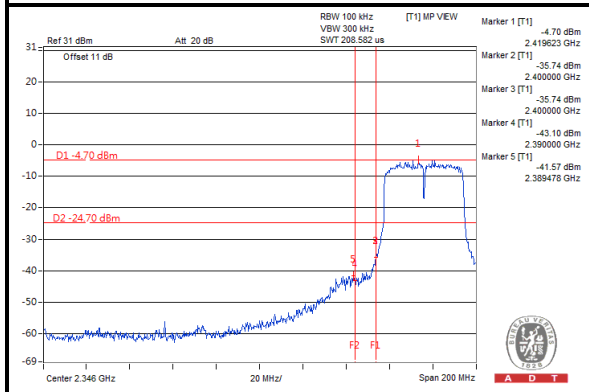
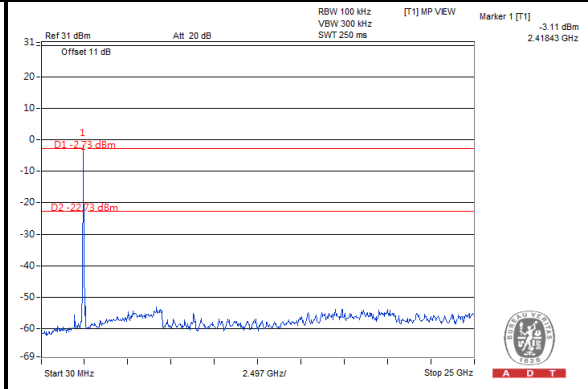
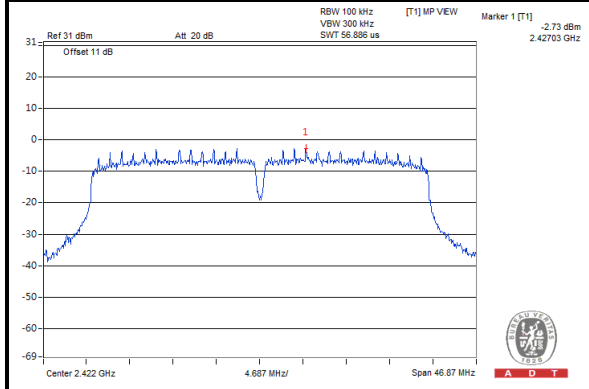

CH 6

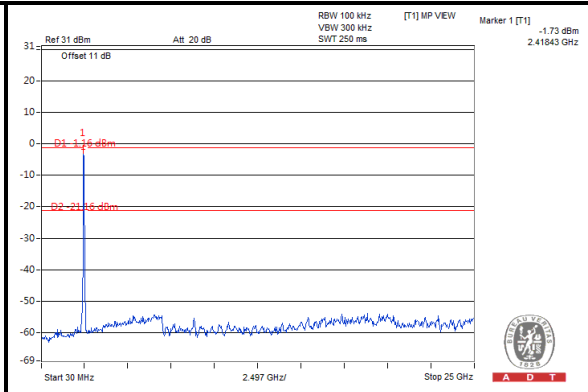
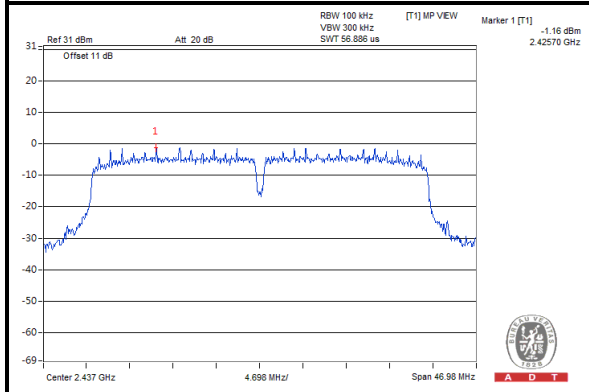



A D T

CH 11

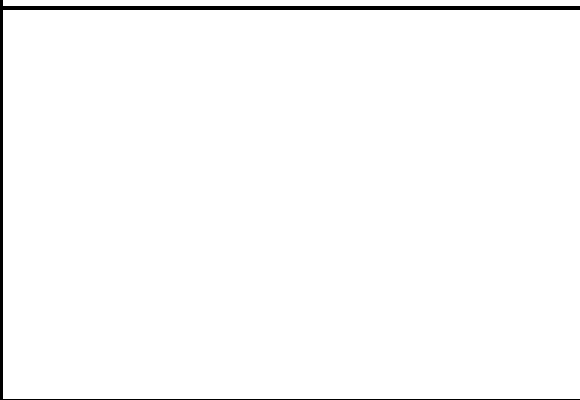
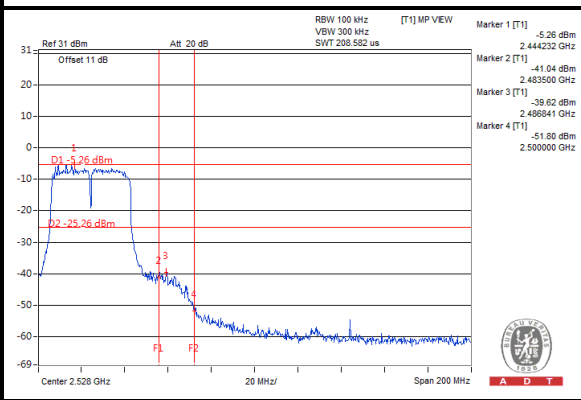
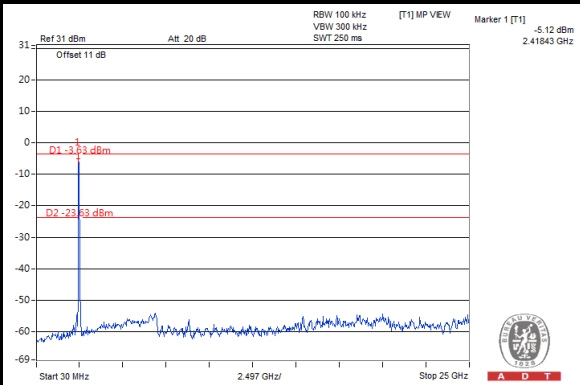
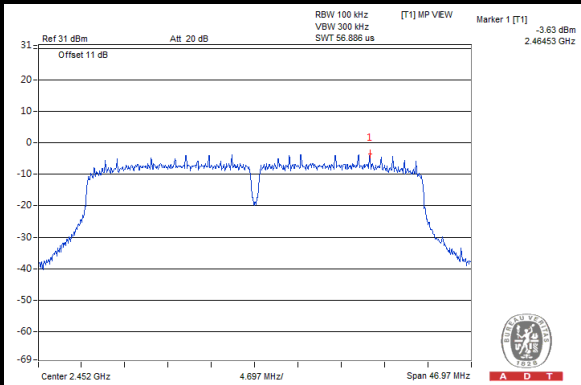



A D T

5. PHOTOGRAPHS OF THE TEST CONFIGURATION

Please refer to the attached file (Test Setup Photo).



6. INFORMATION ON THE TESTING LABORATORIES

We, Bureau Veritas Consumer Products Services (H.K.) Ltd., Taoyuan Branch, were founded in 1988 to provide our best service in EMC, Radio, Telecom and Safety consultation. Our laboratories are accredited and approved according to ISO/IEC 17025.

If you have any comments, please feel free to contact us at the following:

Linko EMC/RF Lab:

Tel: 886-2-26052180

Fax: 886-2-26051924

Hsin Chu EMC/RF Lab:

Tel: 886-3-5935343

Fax: 886-3-5935342

Hwa Ya EMC/RF/Safety Telecom Lab:

Tel: 886-3-3183232

Fax: 886-3-3270892

Email: service.adt@tw.bureauveritas.com

Web Site: www.bureauveritas-adt.com

The address and road map of all our labs can be found in our web site also.



A D T

7. APPENDIX A - MODIFICATIONS RECORDERS FOR ENGINEERING CHANGES TO THE EUT BY THE LAB

No any modifications are made to the EUT by the lab during the test.

---END---