



FCC SAR Test Report

Report No. : SA120822C31
Applicant : Motorola Mobility, Inc.
Address : No. 1, Wang Jing East Road, Chao Yang District, Beijing, 100102, P. R. China
Product : Mobile Phone
FCC ID : IHDP56NA1
Brand : Motorola
Model No. : XT901
Standards : FCC 47 CFR Part 2 (2.1093) / IEEE C95.1:1991 / IEEE 1528:2003
FCC OET Bulletin 65 Supplement C (Edition 01-01)
KDB 248227 D01 v01r02 / KDB 648474 D01 v01r05 / KDB 941225 D01 v02
KDB 941225 D03 v01 / KDB 941225 D05 v01 / KDB 941225 D06 v01
Date of Testing : Sep. 01, 2012 ~ Oct. 20, 2012

CERTIFICATION: The above equipment have been tested by **Bureau Veritas Consumer Products Services (H.K.) Ltd., Taoyuan Branch - Taiwan HwaYa Lab**, and found compliance with the requirement of the above standards. The test record, data evaluation & Equipment Under Test (EUT) configurations represented herein are true and accurate accounts of the measurements of the sample's SAR characteristics under the conditions specified in this report. It should not be reproduced except in full, without the written approval of our laboratory. The client should not use it to claim product certification, approval, or endorsement by TAF or any government agencies.

Prepared By : Ivonne Wu
Ivonne Wu / Senior Specialist

Approved By : Roy Wu
Roy Wu / Manager



This report is for your exclusive use. Any copying or replication of this report to or for any other person or entity, or use of our name or trademark, is permitted only with our prior written permission. This report sets forth our findings solely with respect to the test samples identified herein. The results set forth in this report are not indicative or representative of the quality or characteristics of the lot from which a test sample was taken or any similar or identical product unless specifically and expressly noted. Our report includes all of the tests requested by you and the results thereof based upon the information that you provided to us. You have 60 days from date of issuance of this report to notify us of any material error or omission caused by our negligence, provided, however, that such notice shall be in writing and shall specifically address the issue you wish to raise. A failure to raise such issue within the prescribed time shall constitute your unqualified acceptance of the completeness of this report, the tests conducted and the correctness of the report contents. Unless specific mention, the uncertainty of measurement has been explicitly taken into account to declare the compliance or non-compliance to the specification.



Table of Contents

Release Control Record 3

1. Summary of Maximum SAR Value 4

2. Description of Equipment Under Test 5

3. SAR Measurement System 8

 3.1 Definition of Specific Absorption Rate (SAR)..... 8

 3.2 SPEAG DASY System 8

 3.2.1 Robot..... 9

 3.2.2 Probes..... 10

 3.2.3 Data Acquisition Electronics (DAE) 10

 3.2.4 Phantoms 11

 3.2.5 Device Holder..... 12

 3.2.6 System Validation Dipoles 12

 3.2.7 Tissue Simulating Liquids..... 13

 3.3 SAR System Verification 15

 3.4 SAR Measurement Procedure 16

 3.4.1 Area & Zoom Scan Procedure 16

 3.4.2 Volume Scan Procedure..... 16

 3.4.3 Power Drift Monitoring..... 16

 3.4.4 Spatial Peak SAR Evaluation 17

 3.4.5 SAR Averaged Methods 17

4. SAR Measurement Evaluation 18

 4.1 EUT Configuration and Setting..... 18

 4.2 EUT Testing Position 22

 4.3 Tissue Verification 25

 4.4 System Verification..... 26

 4.5 Conducted Power Results..... 27

 4.6 SAR Testing Results..... 33

 4.6.1 SAR Results for Head 33

 4.6.2 SAR Results for Body..... 39

 4.6.3 Simultaneous Multi-band Transmission Evaluation 46

5. Calibration of Test Equipment..... 59

6. Measurement Uncertainty 60

7. Information on the Testing Laboratories 61

Appendix A. SAR Plots of System Verification

Appendix B. SAR Plots of SAR Measurement

Appendix C. Calibration Certificate for Probe and Dipole

Appendix D. Photographs of EUT and Setup

Appendix E. Supplementary SAR Test Result



Release Control Record

Issue No.	Reason for Change	Date Issued
R01	Original release	Oct. 22, 2012

1. Summary of Maximum SAR Value

Mode / Band	Test Position	SAR-1g (W/kg)
CDMA2000 BC0	Head	1.08
	Body Worn (2.5 cm Gap)	0.395
	Hotspot Mode (1.0 cm Gap)	1.14
CDMA2000 BC1	Head	0.621
	Body Worn (2.5 cm Gap)	0.065
	Hotspot Mode (1.0 cm Gap)	1.12
CDMA2000 BC15	Head	0.66
	Body Worn (2.5 cm Gap)	0.119
	Hotspot Mode (1.0 cm Gap)	1.19
LTE Band 2	Head	0.514
	Body Worn (2.5 cm Gap)	0.133
	Hotspot Mode (1.0 cm Gap)	0.69
LTE Band 4	Head	0.69
	Body Worn (2.5 cm Gap)	0.209
	Hotspot Mode (1.0 cm Gap)	0.752
LTE Band 5	Head	1.05
	Body Worn (2.5 cm Gap)	0.246
	Hotspot Mode (1.0 cm Gap)	0.833
LTE Band 12	Head	0.582
	Body Worn (2.5 cm Gap)	0.423
	Hotspot Mode (1.0 cm Gap)	0.78
LTE Band 25	Head	0.624
	Body Worn (2.5 cm Gap)	0.168
	Hotspot Mode (1.0 cm Gap)	0.8
WLAN 2.4GHz	Head	0.506
	Body Worn (2.5 cm Gap)	0.126
	Hotspot Mode (1.0 cm Gap)	0.419
Bluetooth	Head	N/A
	Body Worn (2.5 cm Gap)	N/A
	Hotspot Mode (1.0 cm Gap)	N/A
Multi-band SAR	Head	Not Required
	Body Worn (2.5 cm Gap)	Not Required
	Hotspot Mode (1.0 cm Gap)	1.51

Note:

1. The SAR limit (**1.6 W/kg**) for general population/uncontrolled exposure is specified in FCC 47 CFR part 2 (2.1093) and ANSI/IEEE C95.1-1991.
2. Since the Bluetooth maximum power is less than P_{Ref} , SAR testing for Bluetooth is not required.

2. Description of Equipment Under Test

EUT Type	Mobile Phone
FCC ID	IHDP56NA1
Brand Name	Motorola
Model Name	XT901
Tx Frequency Bands (Unit: MHz)	CDMA BC0 : 824 ~ 849 CDMA BC1 : 1850 ~ 1910 CDMA BC15 : 1710 ~ 1755 LTE Band 2 : 1850 ~ 1910 LTE Band 4 : 1710 ~ 1755 LTE Band 5 : 824 ~ 849 LTE Band 12 : 699 ~ 716 LTE Band 25 : 1850 ~ 1915 WLAN : 2400 ~ 2483.5 Bluetooth : 2400 ~ 2483.5
Uplink Modulations	CDMA : QPSK LTE : QPSK, 16QAM 802.11b : DSSS 802.11g/n : OFDM Bluetooth : GFSK
Maximum AVG Conducted Power (Unit: dBm)	CDMA BC0 : 25.23 CDMA BC1 : 25.18 CDMA BC15 : 25.22 LTE Band 2 : 24.18 LTE Band 4 : 24.40 LTE Band 5 : 24.00 LTE Band 12 : 24.39 LTE Band 25 : 24.19 802.11b : 19.60 802.11g : 14.91 802.11n HT20 : 14.93 802.11n HT40 : 13.56
Maximum Peak Conducted Power (Unit: dBm)	Bluetooth : 10.16
Antenna Type	Fixed Internal Antenna
EUT Stage	Identical Prototype

Note:

1. The above EUT information is declared by manufacturer and for more detailed features description please refers to the manufacturer's specifications or User's Manual.

FCC SAR Test Report

<EUT WIRELESS HOTSPOT OPERATION>

To meet the 10-mm separation distance for the "Mobile Hotspot" feature, the RF powers of certain transmitters are limited, as described below, and in the Operational Description exhibit. Power reductions are also applied in other simultaneous use cases. The magnitudes of these reductions are described below, based on the applicable usage scenarios.

<EUT OPERATING MODES AND SIMULTANEITY>

1. Wi-Fi Power Reduction Schemes for SAR Compliance under Simultaneous Operation.

During simultaneous Wi-Fi operations (i.e. Wi-Fi operation concurrent with wide-area network operation like CDMA or LTE) the phone reduces the maximum power limits of its Wi-Fi transmitter, as determined by the closed-loop power control detector. The reduction occurs as outlined in the table below:

WWAN and WLAN Condition		WLAN 2.4 GHz Power Reduction Applied
WWAN State	WLAN State	
Inactive	Station	0 dB reduction
Data Inactive or Voice Only	Direct ¹	6 dB reduction
Voice Only	Station	6 dB reduction
Active Data ² and/or Voice	Direct or Hotspot	5 dB reduction

Note :

1. Because there is no active data session over WWAN, Mobile Hotspot is technically not possible.
2. Station mode cannot operate simultaneously with a WWAN data session.

2. WWAN Power Reduction Schemes for SAR Compliance under Simultaneous Operation (excluding Personal Hotspot).

During SVLTE operation (i.e., simultaneous voice operation and LTE operation), the phone reduces the maximum power limit of its LTE transmitter as determined by the closed loop power control detector. Limit reduction applies regardless of modulation/RB configuration. The reduction occurs as outlined in the table below:

CDMA2000 Condition		LTE Outcome
CDMA2000 850 MHz	CDMA2000 1700/1900 MHz	LTE All Bands
Power > 18 dBm	---	6 dB reduction
---	Power > 18 dBm	6 dB reduction
Power ≤ 18 dBm	---	0 dB reduction
---	Power ≤ 18 dBm	0 dB reduction

Should these conditions overlap (i.e., mobile hotspot during an SVLTE session), the above reductions are applied unless otherwise noted

FCC SAR Test Report

3. CDMA Power Reduction Schemes for SAR Compliance under Simultaneous Operation (Personal Hotspot).

In Personal Hotspot mode, the power reduction is modified per the table below. Note that all power reduction modifications apply only in the CDMA 1900 MHz band.

Wi-Fi Condition	CDMA 1900 MHz Conditions		CDMA 1900 Outcomes	
	CDMA2000 1900 MHz	CDMA EVDO 1900 MHz	CDMA2000 1900 MHz	CDMA EVDO 1900 MHz
Mobile Hotspot or Direct	On	Off	2 dB ¹ or 7.5 dB ² reduction	N/A
Mobile Hotspot or Direct	Off	On	N/A	2 dB ¹ or 7.5 dB ² reduction

Note :

1. When earpiece audio is present, the radio software assumes that the device is operating at the head; then the CDMA2000 2 dB reduction is applied. Such conditions would be CDMA2000 in 1900 MHz with LTE B2/4/5/12/25 simultaneously.
2. When no earpiece audio is present, the radio software assumes the device is operating at the 10-mm hotspot separation from the body. In this case, the CDMA2000 7.5 dB reduction is applied. Such conditions would be CDMA2000 in 1900 MHz with LTE B2/4/5/12/25 simultaneously.

In Personal Hotspot mode, the power reductions are modified per the table below. Note that all power reduction modifications apply only in the CDMA 1700 MHz band.

Wi-Fi Condition	CDMA 1700 MHz Conditions		CDMA 1700 Outcomes	
	CDMA2000 1700 MHz	CDMA EVDO 1700 MHz	CDMA2000 1700 MHz	CDMA EVDO 1700 MHz
Mobile Hotspot or Direct	On	Off	0 dB ¹ or 7.5 dB ² reduction	N/A
Mobile Hotspot or Direct	Off	On	N/A	2 dB ¹ or 7.5 dB ² reduction

Note :

1. When earpiece audio is present, the radio software assumes that the device is operating at the head; then the CDMA2000 0 dB reduction is applied. Such conditions would be CDMA2000 in 1700 MHz with LTE B2/4/5/12/25 simultaneously.
2. When no earpiece audio is present, the radio software assumes the device is operating at the 10-mm hotspot separation from the body. In this case, the CDMA2000 7.5 dB reduction is applied. Such conditions would be CDMA2000 in 1700 MHz with LTE B2/4/5/12/25 simultaneously.

4. LTE Power Reduction Schemes for SAR Compliance under Simultaneous Operation (Personal Hotspot).

In Personal Hotspot mode, the power reductions are modified per the table below.

LTE Operating Condition	LTE (All Bands) Power Cutback
Anytime in Personal Hotspot Mode, regardless of other transmit operating conditions.	5 dB

3. SAR Measurement System

3.1 Definition of Specific Absorption Rate (SAR)

SAR is related to the rate at which energy is absorbed per unit mass in an object exposed to a radio field. The SAR distribution in a biological body is complicated and is usually carried out by experimental techniques or numerical modeling. The standard recommends limits for two tiers of groups, occupational/controlled and general population/uncontrolled, based on a person's awareness and ability to exercise control over his or her exposure. In general, occupational/controlled exposure limits are higher than the limits for general population/uncontrolled.

The SAR definition is the time derivative (rate) of the incremental energy (dW) absorbed by (dissipated in) an incremental mass (dm) contained in a volume element (dv) of a given density (ρ). The equation description is as below:

$$\text{SAR} = \frac{d}{dt} \left(\frac{dW}{dm} \right) = \frac{d}{dt} \left(\frac{dW}{\rho dv} \right)$$

SAR is expressed in units of Watts per kilogram (W/kg)

SAR measurement can be related to the electrical field in the tissue by

$$\text{SAR} = \frac{\sigma |E|^2}{\rho}$$

Where: σ is the conductivity of the tissue, ρ is the mass density of the tissue and E is the RMS electrical field strength.

3.2 SPEAG DASY System

DASY system consists of high precision robot, probe alignment sensor, phantom, robot controller, controlled measurement server and near-field probe. The robot includes six axes that can move to the precision position of the DASY4/5 software defined. The DASY software can define the area that is detected by the probe. The robot is connected to controlled box. Controlled measurement server is connected to the controlled robot box. The DAE includes amplifier, signal multiplexing, AD converter, offset measurement and surface detection. It is connected to the Electro-optical coupler (ECO). The ECO performs the conversion from the optical into digital electric signal of the DAE and transfers data to the PC.

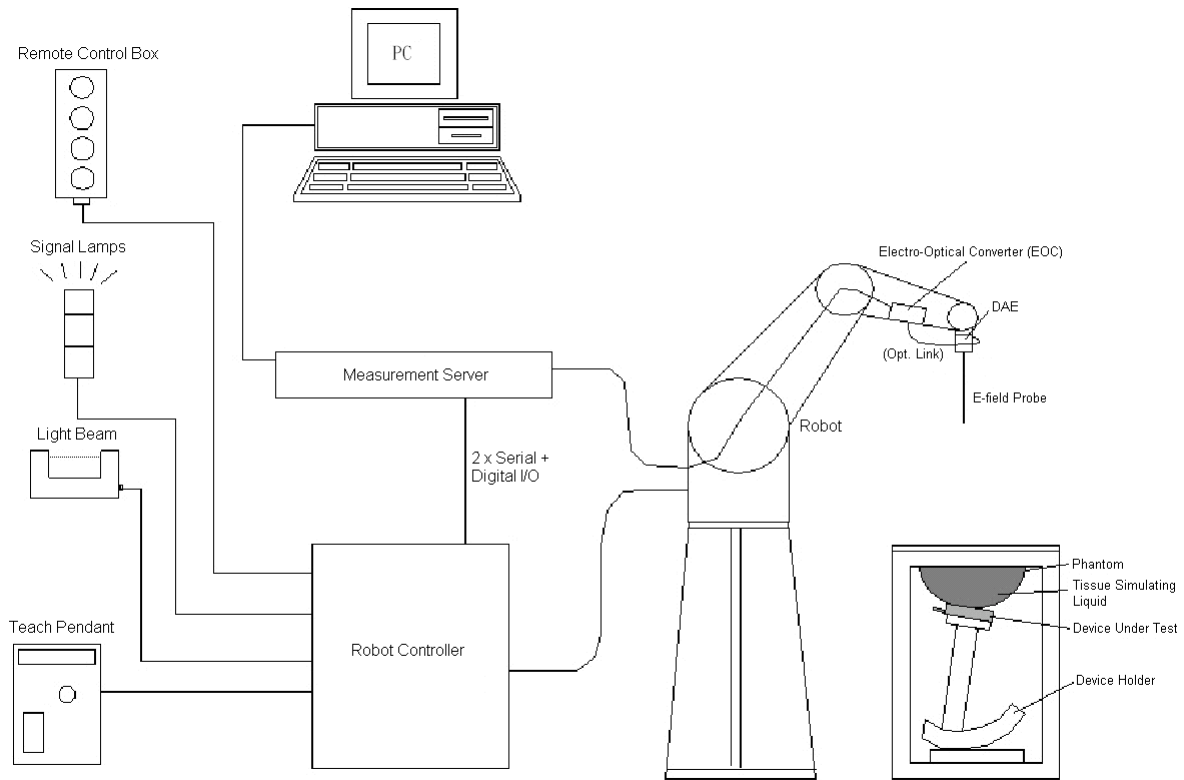
Fig-3.1 DASY System Setup
3.2.1 Robot

The DASY system uses the high precision robots from Stäubli SA (France). For the 6-axis controller system, the robot controller version (DASY4: CS7MB; DASY5: CS8c) from Stäubli is used. The Stäubli robot series have many features that are important for our application:

- High precision (repeatability ± 0.035 mm)
- High reliability (industrial design)
- Jerk-free straight movements
- Low ELF interference (the closed metallic construction shields against motor control fields)



Fig-3.2 DASY4

Fig-3.3 DASY5

FCC SAR Test Report

3.2.2 Probes

The SAR measurement is conducted with the dosimetric probe. The probe is specially designed and calibrated for use in liquid with high permittivity. The dosimetric probe has special calibration in liquid at different frequency.

Model	EX3DV4	
Construction	Symmetrical design with triangular core. Built-in shielding against static charges. PEEK enclosure material (resistant to organic solvents, e.g., DGBE).	
Frequency	10 MHz to 6 GHz Linearity: ± 0.2 dB	
Directivity	± 0.3 dB in HSL (rotation around probe axis) ± 0.5 dB in tissue material (rotation normal to probe axis)	
Dynamic Range	10 μ W/g to 100 mW/g Linearity: ± 0.2 dB (noise: typically < 1 μ W/g)	
Dimensions	Overall length: 337 mm (Tip: 20 mm) Tip diameter: 2.5 mm (Body: 12 mm) Typical distance from probe tip to dipole centers: 1 mm	

Model	ES3DV3	
Construction	Symmetrical design with triangular core. Interleaved sensors. Built-in shielding against static charges. PEEK enclosure material (resistant to organic solvents, e.g., DGBE).	
Frequency	10 MHz to 4 GHz Linearity: ± 0.2 dB	
Directivity	± 0.2 dB in HSL (rotation around probe axis) ± 0.3 dB in tissue material (rotation normal to probe axis)	
Dynamic Range	5 μ W/g to 100 mW/g Linearity: ± 0.2 dB	
Dimensions	Overall length: 337 mm (Tip: 20 mm) Tip diameter: 3.9 mm (Body: 12 mm) Distance from probe tip to dipole centers: 2.0 mm	

3.2.3 Data Acquisition Electronics (DAE)

Model	DAE3, DAE4	
Construction	Signal amplifier, multiplexer, A/D converter and control logic. Serial optical link for communication with DASY4/5 embedded system (fully remote controlled). Two step probe touch detector for mechanical surface detection and emergency robot stop.	
Measurement Range	-100 to +300 mV (16 bit resolution and two range settings: 4mV, 400mV)	
Input Offset Voltage	< 5 μ V (with auto zero)	
Input Bias Current	< 50 fA	
Dimensions	60 x 60 x 68 mm	

FCC SAR Test Report

3.2.4 Phantoms

Model	Twin SAM	
Construction	The shell corresponds to the specifications of the Specific Anthropomorphic Mannequin (SAM) phantom defined in IEEE 1528 and IEC 62209-1. It enables the dosimetric evaluation of left and right hand phone usage as well as body mounted usage at the flat phantom region. A cover prevents evaporation of the liquid. Reference markings on the phantom allow the complete setup of all predefined phantom positions and measurement grids by teaching three points with the robot.	
Material	Vinylester, glass fiber reinforced (VE-GF)	
Shell Thickness	2 ± 0.2 mm (6 ± 0.2 mm at ear point)	
Dimensions	Length: 1000 mm Width: 500 mm Height: adjustable feet	
Filling Volume	approx. 25 liters	

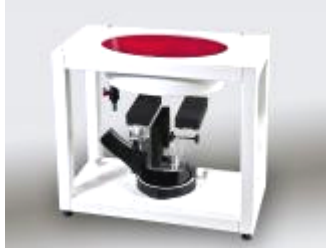
Model	ELI	
Construction	Phantom for compliance testing of handheld and body-mounted wireless devices in the frequency range of 30 MHz to 6 GHz. ELI is fully compatible with the IEC 62209-2 standard and all known tissue simulating liquids. ELI has been optimized regarding its performance and can be integrated into our standard phantom tables. A cover prevents evaporation of the liquid. Reference markings on the phantom allow installation of the complete setup, including all predefined phantom positions and measurement grids, by teaching three points. The phantom is compatible with all SPEAG dosimetric probes and dipoles.	
Material	Vinylester, glass fiber reinforced (VE-GF)	
Shell Thickness	2.0 ± 0.2 mm (bottom plate)	
Dimensions	Major axis: 600 mm Minor axis: 400 mm	
Filling Volume	approx. 30 liters	

FCC SAR Test Report

3.2.5 Device Holder

Model	Mounting Device	
Construction	In combination with the Twin SAM Phantom or ELI4, the Mounting Device enables the rotation of the mounted transmitter device in spherical coordinates. Rotation point is the ear opening point. Transmitter devices can be easily and accurately positioned according to IEC, IEEE, FCC or other specifications. The device holder can be locked for positioning at different phantom sections (left head, right head, flat).	
Material	POM	

Model	Laptop Extensions Kit	
Construction	Simple but effective and easy-to-use extension for Mounting Device that facilitates the testing of larger devices according to IEC 62209-2 (e.g., laptops, cameras, etc.). It is lightweight and fits easily on the upper part of the Mounting Device in place of the phone positioner.	
Material	POM, Acrylic glass, Foam	

3.2.6 System Validation Dipoles

Model	D-Serial	
Construction	Symmetrical dipole with 1/4 balun. Enables measurement of feed point impedance with NWA. Matched for use near flat phantoms filled with tissue simulating solutions.	
Frequency	750 MHz to 5800 MHz	
Return Loss	> 20 dB	
Power Capability	> 100 W (f < 1GHz), > 40 W (f > 1GHz)	

FCC SAR Test Report

3.2.7 Tissue Simulating Liquids

For SAR measurement of the field distribution inside the phantom, the phantom must be filled with homogeneous tissue simulating liquid to a depth of at least 15 cm. For head SAR testing, the liquid height from the ear reference point (ERP) of the phantom to the liquid top surface is larger than 15 cm. For body SAR testing, the liquid height from the center of the flat phantom to the liquid top surface is larger than 15 cm. The nominal dielectric values of the tissue simulating liquids in the phantom and the tolerance of 5% are listed in Table-3.1.

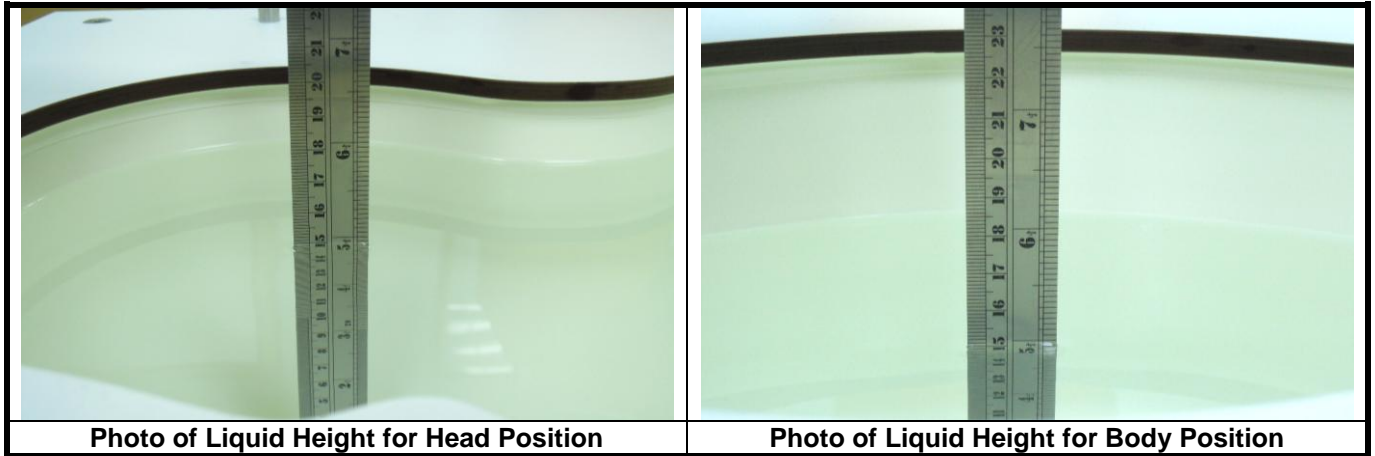

The dielectric properties of the head tissue simulating liquids are defined in IEEE 1528 and FCC OET 65 Supplement C Appendix C. For the body tissue simulating liquids, the dielectric properties are defined in FCC OET 65 Supplement C Appendix C. The dielectric properties of the tissue simulating liquids were verified prior to the SAR evaluation using an Agilent 85070D Dielectric Probe Kit and an Agilent Network Analyzer.

Table-3.1 Targets of Tissue Simulating Liquid

Frequency (MHz)	Target Permittivity	Range of $\pm 5\%$	Target Conductivity	Range of $\pm 5\%$
For Head				
750	41.9	39.8 ~ 44.0	0.89	0.85 ~ 0.93
835	41.5	39.4 ~ 43.6	0.90	0.86 ~ 0.95
1750	40.1	38.1 ~ 42.1	1.37	1.30 ~ 1.44
1900	40.0	38.0 ~ 42.0	1.40	1.33 ~ 1.47
2450	39.2	37.2 ~ 41.2	1.80	1.71 ~ 1.89
For Body				
750	55.5	52.7 ~ 58.3	0.96	0.91 ~ 1.01
835	55.2	52.4 ~ 58.0	0.97	0.92 ~ 1.02
1750	53.4	50.7 ~ 56.1	1.49	1.42 ~ 1.56
1900	53.3	50.6 ~ 56.0	1.52	1.44 ~ 1.60
2450	52.7	50.1 ~ 55.3	1.95	1.85 ~ 2.05



FCC SAR Test Report

The following table gives the recipes for tissue simulating liquids.

Table-3.2 Recipes of Tissue Simulating Liquid

Tissue Type	Bactericide	DGBE	HEC	NaCl	Sucrose	Triton X-100	Water	Diethylene Glycol Mono-hexylether
H750	0.2	-	0.2	1.5	56.0	-	42.1	-
H835	0.2	-	0.2	1.5	57.0	-	41.1	-
H1750	-	47.0	-	0.4	-	-	52.6	-
H1900	-	44.5	-	0.2	-	-	55.3	-
H2450	-	45.0	-	0.1	-	-	54.9	-
B750	0.2	-	0.2	0.8	48.8	-	50.0	-
B835	0.2	-	0.2	0.9	48.5	-	50.2	-
B1750	-	31.0	-	0.2	-	-	68.8	-
B1900	-	29.5	-	0.3	-	-	70.2	-
B2450	-	31.4	-	0.1	-	-	68.5	-

3.3 SAR System Verification

The system check verifies that the system operates within its specifications. It is performed daily or before every SAR measurement. The system check uses normal SAR measurements in the flat section of the phantom with a matched dipole at a specified distance. The system verification setup is shown as below.

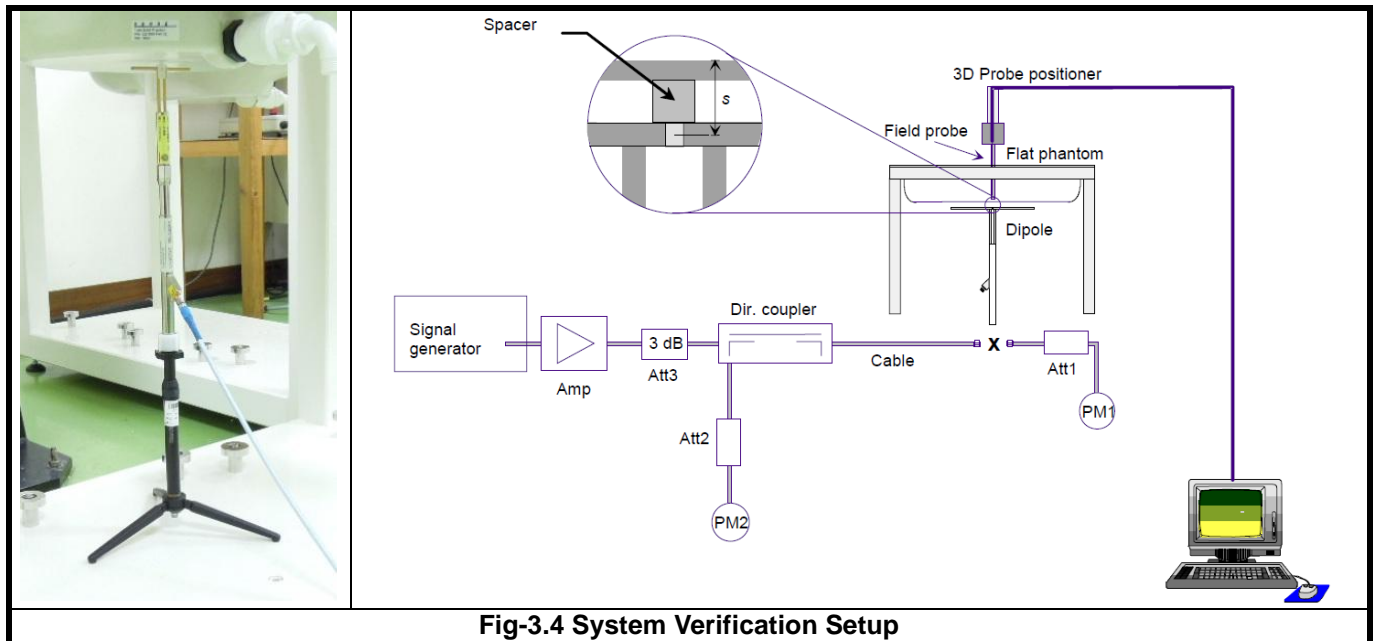

Fig-3.4 System Verification Setup

The validation dipole is placed beneath the flat phantom with the specific spacer in place. The distance spacer is touch the phantom surface with a light pressure at the reference marking and be oriented parallel to the long side of the phantom. The power meter PM1 measures the forward power at the location of the system check dipole connector. The signal generator is adjusted for the desired forward power (250 mW is used for 700 MHz to 3 GHz, 100 mW is used for 3.5 GHz to 6 GHz) at the dipole connector and the power meter PM2 is read at that level. After connecting the cable to the dipole, the signal generator is readjusted for the same reading at power meter PM2.

After system check testing, the SAR result will be normalized to 1W forward input power and compared with the reference SAR value derived from validation dipole certificate report. The deviation of system check should be within 10 %.

3.4 SAR Measurement Procedure

According to the SAR test standard, the recommended procedure for assessing the peak spatial-average SAR value consists of the following steps:

- (a) Power reference measurement
- (b) Area scan
- (c) Zoom scan
- (d) Power drift measurement

The SAR measurement procedures for each of test conditions are as follows:

- (a) Make EUT to transmit maximum output power
- (b) Measure conducted output power through RF cable
- (c) Place the EUT in the specific position of phantom
- (d) Perform SAR testing steps on the DASYS system
- (e) Record the SAR value

3.4.1 Area & Zoom Scan Procedure

First Area Scan is used to locate the approximate location(s) of the local peak SAR value(s). The measurement grid within an Area Scan is defined by the grid extent, grid step size and grid offset. Next, in order to determine the EM field distribution in a three-dimensional spatial extension, Zoom Scan is required. The Zoom Scan measures 5x5x7 points with step size 8, 8 and 5 mm for below 3 GHz, and 7x7x9 points with step size 4, 4 and 2.5 mm for above 5 GHz. The Zoom Scan is performed around the highest E-field value to determine the averaged SAR-distribution over 10 g.

3.4.2 Volume Scan Procedure

The volume scan is used for assess overlapping SAR distributions for antennas transmitting in different frequency bands. It is equivalent to an oversized zoom scan used in standalone measurements. The measurement volume will be used to enclose all the simultaneous transmitting antennas. For antennas transmitting simultaneously in different frequency bands, the volume scan is measured separately in each frequency band. In order to sum correctly to compute the 1g aggregate SAR, the EUT remain in the same test position for all measurements and all volume scan use the same spatial resolution and grid spacing. When all volume scan were completed, the software, SEMCAD postprocessor can combine and subsequently superpose these measurement data to calculating the multiband SAR.

3.4.3 Power Drift Monitoring

All SAR testing is under the EUT install full charged battery and transmit maximum output power. In DASYS measurement software, the power reference measurement and power drift measurement procedures are used for monitoring the power drift of EUT during SAR test. Both these procedures measure the field at a specified reference position before and after the SAR testing. The software will calculate the field difference in dB. If the power drift more than 5%, the SAR will be retested.

FCC SAR Test Report

3.4.4 Spatial Peak SAR Evaluation

The procedure for spatial peak SAR evaluation has been implemented according to the test standard. It can be conducted for 1g and 10g, as well as for user-specific masses. The DASY software includes all numerical procedures necessary to evaluate the spatial peak SAR value.

The base for the evaluation is a "cube" measurement. The measured volume must include the 1g and 10g cubes with the highest averaged SAR values. For that purpose, the center of the measured volume is aligned to the interpolated peak SAR value of a previously performed area scan.

The entire evaluation of the spatial peak values is performed within the post-processing engine (SEMCAD). The system always gives the maximum values for the 1g and 10g cubes. The algorithm to find the cube with highest averaged SAR is divided into the following stages:

- (a) Extraction of the measured data (grid and values) from the Zoom Scan
- (b) Calculation of the SAR value at every measurement point based on all stored data (A/D values and measurement parameters)
- (c) Generation of a high-resolution mesh within the measured volume
- (d) Interpolation of all measured values from the measurement grid to the high-resolution grid
- (e) Extrapolation of the entire 3-D field distribution to the phantom surface over the distance from sensor to surface
- (f) Calculation of the averaged SAR within masses of 1g and 10g

3.4.5 SAR Averaged Methods

In DASY, the interpolation and extrapolation are both based on the modified Quadratic Shepard's method. The interpolation scheme combines a least-square fitted function method and a weighted average method which are the two basic types of computational interpolation and approximation.

Extrapolation routines are used to obtain SAR values between the lowest measurement points and the inner phantom surface. The extrapolation distance is determined by the surface detection distance and the probe sensor offset. The uncertainty increases with the extrapolation distance. To keep the uncertainty within 1% for the 1 g and 10 g cubes, the extrapolation distance should not be larger than 5 mm.



4. SAR Measurement Evaluation

4.1 EUT Configuration and Setting

The EUT is a voice/data transmitter device that contains two WWAN transmitters (one is for CDMA2000, and the other is for LTE). Confirming the LTE transmitter follows 3GPP standards, is category 3, BW 5/10 MHz, band 2/4/5/12/25, supports QPSK / 16QAM modulations, and supports data transmission only. Tested per 3GPP 36.521 maximum transmit procedures for both QPSK / 16QAM.

LTE Maximum Power Reduction in accordance with 3GPP 36.101: Power Reduction in accordance to 3GPP is active all times during LTE operation.

Modulation	Channel bandwidth / Transmission bandwidth configuration (RB)		3GPP Requirement (dB)	LTE MPR Setting (dB)
	BW 5 MHz	BW 10 MHz		
QPSK	> 8	> 12	<= 1	1
16QAM	<= 8	<= 12	<= 1	1
16QAM	> 8	> 12	<= 2	2

Note: MPR is according to the standard and implemented in the circuit (mandatory).

In addition, the device is compliant with A-MPR requirements defined in 36.101 section 6.2.4 that may be required to meet 3GPP Adjacent Channel Leakage Ratio (“ACLR”) requirements. A-MPR was disabled for all FCC compliance testing.

A simultaneous CDMA 1xRTT voice and LTE data connection is referred to as “SVLTE”. The transmitters are independent in respect to the RF chains as each transmitter has dedicated RF circuitry (PA and RF filtering) and a unique transmit antenna. The device also contains an additional antenna associated with receiver diversity or unlicensed transmitters. The LTE Uplink MIMO configuration is 1x2 (1 Uplink antenna and 2 Downlink antennas).

Although the RF circuits are independent for both transmitters, the chipset solution incorporated SVLTE implementation does include electrical connections between the voice and data transmitters such that the device can coordinate the transmit power of both transmitters. That said the transmitters operate independently in the sense that they independently support voice or data connection without interaction between the modems or signaling from the WWAN network.

FCC SAR Test Report

<Antenna Location>

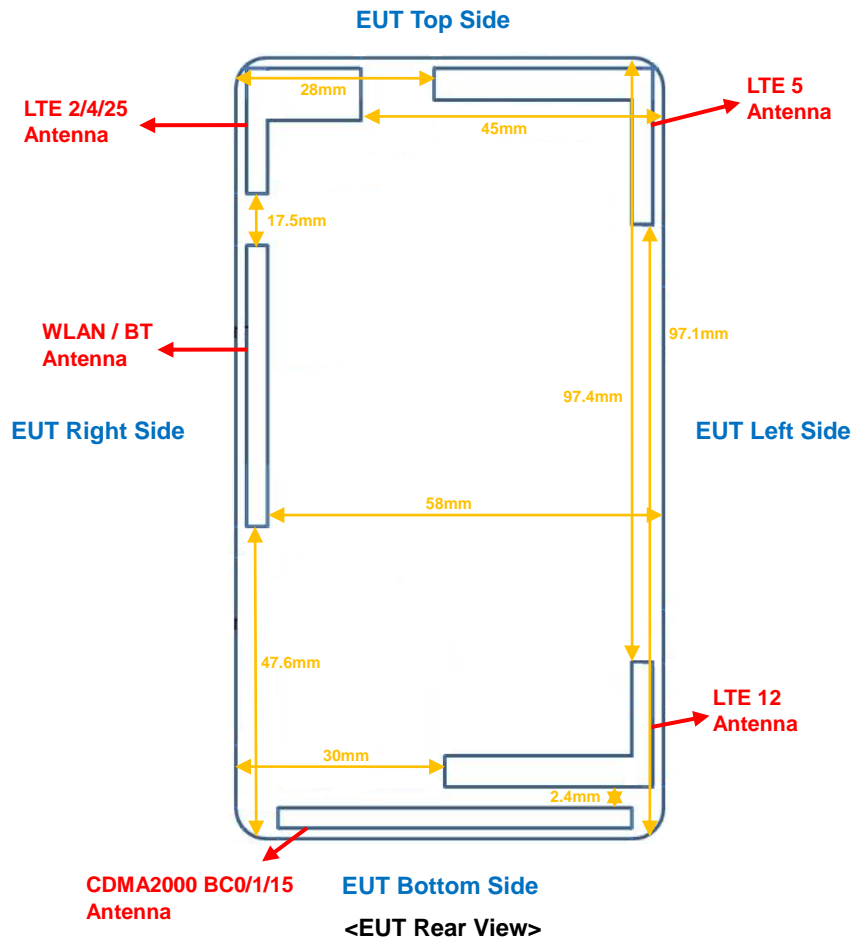

This device supports WiFi hotspot function, so body SAR was tested under 1 cm for the surfaces / slide edges where a transmitting antenna is within 2.5 cm from the edge. Since the SAR is required for antenna located within 2.5 cm from edge, SAR testing for each antenna is listed as below.

CDMA Antenna : Front Face, Rear Face, Left Side, Right Side, Bottom Side

LTE 2/4/25 Antenna : Front Face, Rear Face, Right Side, Top Side

LTE 5 Antenna : Front Face, Rear Face, Left Side, Top Side

LTE 12 Antenna : Front Face, Rear Face, Left Side, Bottom Side

WLAN / BT Antenna : Front Face, Rear Face, Right Side



FCC SAR Test Report

A D T

The simultaneous transmission possibilities are listed as below.

Simultaneous TX Combination	Configuration	Head (Voice / VoIP)	Body Worn (Voice / VoIP)	Hotspot (Data)
1	CDMA BC0 (Voice / Data) + WLAN / BT (Data)	Yes	Yes	Yes
2	CDMA BC1 (Voice / Data) + WLAN / BT (Data)	Yes	Yes	Yes
3	CDMA BC15 (Voice / Data) + WLAN / BT (Data)	Yes	Yes	Yes
4	LTE 2 (Data) + WLAN / BT (Data)	Yes	Yes	Yes
5	LTE 4 (Data) + WLAN / BT (Data)	Yes	Yes	Yes
6	LTE 5 (Data) + WLAN / BT (Data)	Yes	Yes	Yes
7	LTE 12 (Data) + WLAN / BT (Data)	Yes	Yes	Yes
8	LTE 25 (Data) + WLAN / BT (Data)	Yes	Yes	Yes
9	CDMA BC0 (Voice) + LTE 2 (Data) + WLAN / BT (Data)	Yes	Yes	Yes
10	CDMA BC0 (Voice) + LTE 4 (Data) + WLAN / BT (Data)	Yes	Yes	Yes
11	CDMA BC0 (Voice) + LTE 5 (Data) + WLAN / BT (Data)	Yes	Yes	Yes
12	CDMA BC0 (Voice) + LTE 12 (Data) + WLAN / BT (Data)	Yes	Yes	Yes
13	CDMA BC0 (Voice) + LTE 25 (Data) + WLAN / BT (Data)	Yes	Yes	Yes
14	CDMA BC1 (Voice) + LTE 2 (Data) + WLAN / BT (Data)	Yes	Yes	Yes
15	CDMA BC1 (Voice) + LTE 4 (Data) + WLAN / BT (Data)	Yes	Yes	Yes
16	CDMA BC1 (Voice) + LTE 5 (Data) + WLAN / BT (Data)	Yes	Yes	Yes
17	CDMA BC1 (Voice) + LTE 12 (Data) + WLAN / BT (Data)	Yes	Yes	Yes
18	CDMA BC1 (Voice) + LTE 25 (Data) + WLAN / BT (Data)	Yes	Yes	Yes
19	CDMA BC15 (Voice) + LTE 2 (Data) + WLAN / BT (Data)	Yes	Yes	Yes
20	CDMA BC15 (Voice) + LTE 4 (Data) + WLAN / BT (Data)	Yes	Yes	Yes
21	CDMA BC15 (Voice) + LTE 5 (Data) + WLAN / BT (Data)	Yes	Yes	Yes
22	CDMA BC15 (Voice) + LTE 12 (Data) + WLAN / BT (Data)	Yes	Yes	Yes
23	CDMA BC15 (Voice) + LTE 25 (Data) + WLAN / BT (Data)	Yes	Yes	Yes

Note :

The WLAN and BT cannot transmit simultaneously, so there is no co-location test requirement for WLAN and BT.



FCC SAR Test Report

For WWAN SAR testing, the EUT was linked and controlled by base station emulator (Agilent E5515C is used for CDMA2000, and Anritsu MT8820C is used for LTE). Communication between the EUT and the emulator was established by air link. The distance between the EUT and the communicating antenna of the emulator is larger than 50 cm and the output power radiated from the emulator antenna is at least 30 dB smaller than the output power of EUT. The EUT was set from the emulator to radiate maximum output power during SAR testing.

For CDMA, SAR is tested under EVDO Rev.0 mode using Reverse Data Channel rate of 153.6 kbps in subtype 0/1 Physical Layer Configurations, and the power control set "All Up Bits". SAR for EVDO Rev.A is not required since its power is less than EVDO Rev.0. SAR for 1xRTT is not required since its power is less than 1/4 dB higher than EVDO Rev.0. The steps for system simulator (Agilent E5515C) setup are as below.

1. Set the Sector ID
2. Set the Protocol Release
3. Set the Cell Band and connecting Channel
4. Set the RTAP Rate
5. Set the power control
6. Press "Start Data Connection" button

For LTE, set the related parameters of operating band, channel bandwidth, uplink channel number, modulation type, and RB in base station simulator. When the EUT has registered and communicated to base station simulator, set the simulator to make EUT transmitting the maximum radiated power. The steps for system simulator (Anritsu MT8820C) setup are as below.

1. Press the "Std" button to select "LTE 22.20S" function
2. Choose the "Screen Select" item to "Fundamental Measurement"
3. Enter the "Common" item
4. Set the Operating Band
5. Set the Channel Bandwidth
6. Set the UL Channel & Frequency
7. Set the Modulation
8. Set the RB number and RB shift
9. Press "Start Call" button when EUT register to the system simulator
10. Set the TX-1 Max. Power to make the EUT transmit maximum output power

For WLAN SAR testing, the EUT has installed WLAN engineering testing software which can provide continuous transmitting RF signal. This RF signal utilized in SAR measurement has almost 100% duty cycle. The data rates for WLAN SAR testing were set in 1 Mbps for 802.11b due to the highest RF output power.

4.2 EUT Testing Position

This EUT was tested in **Right Cheek, Right Tilted, Left Cheek, Left Tilted, Front Face, Rear Face, Right Side, Left Side, Top Side** and **Bottom Side** positions as illustrated below:

1. Define two imaginary lines on the handset

- (a) The vertical centerline passes through two points on the front side of the handset - the midpoint of the width w_t of the handset at the level of the acoustic output, and the midpoint of the width w_b of the bottom of the handset.
- (b) The horizontal line is perpendicular to the vertical centerline and passes through the center of the acoustic output. The horizontal line is also tangential to the face of the handset at point A.
- (c) The two lines intersect at point A. Note that for many handsets, point A coincides with the center of the acoustic output; however, the acoustic output may be located elsewhere on the horizontal line. Also note that the vertical centerline is not necessarily parallel to the front face of the handset, especially for clamshell handsets, handsets with flip covers, and other irregularly shaped handsets.

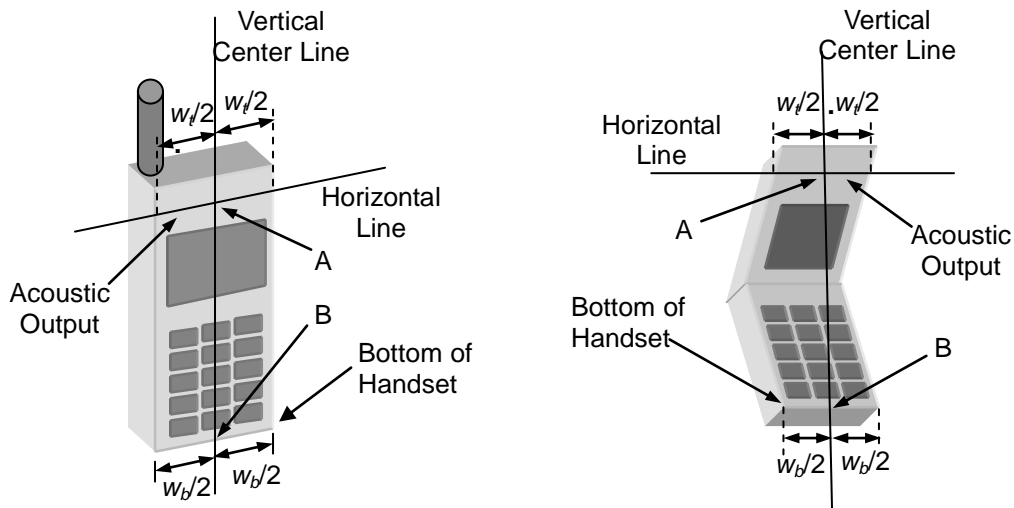
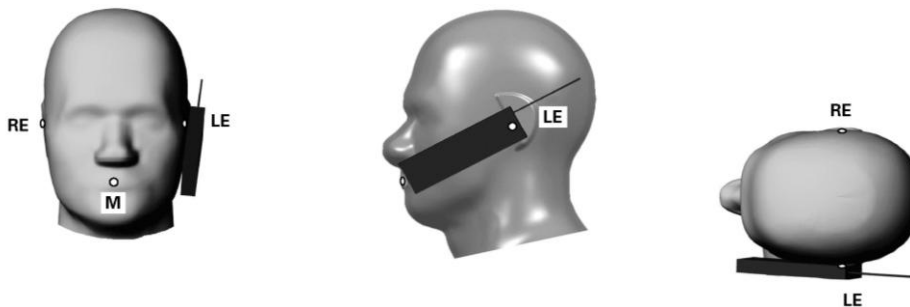

Fig-4.1 Illustration for Handset Vertical and Horizontal Reference Lines

2. Cheek Position

- (a) To position the device with the vertical center line of the body of the device and the horizontal line crossing the center piece in a plane parallel to the sagittal plane of the phantom. While maintaining the device in this plane, align the vertical center line with the reference plane containing the three ear and mouth reference point (M: Mouth, RE: Right Ear, and LE: Left Ear) and align the center of the ear piece with the line RE-LE.
- (b) To move the device towards the phantom with the ear piece aligned with the line LE-RE until the phone touched the ear. While maintaining the device in the reference plane and maintaining the phone contact with the ear, move the bottom of the phone until any point on the front side is in contact with the cheek of the phantom or until contact with the ear is lost (see Fig-4.2).

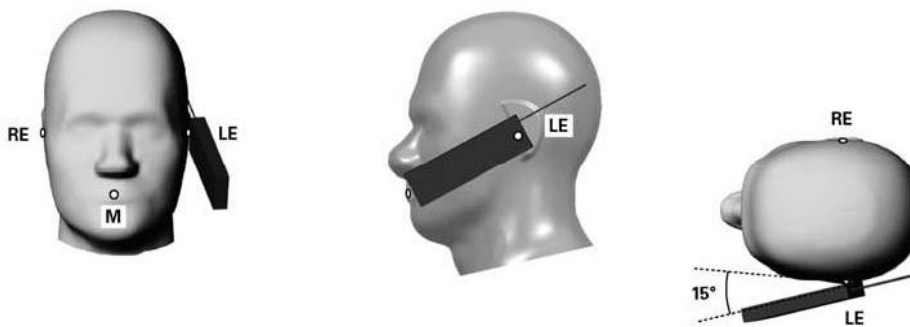
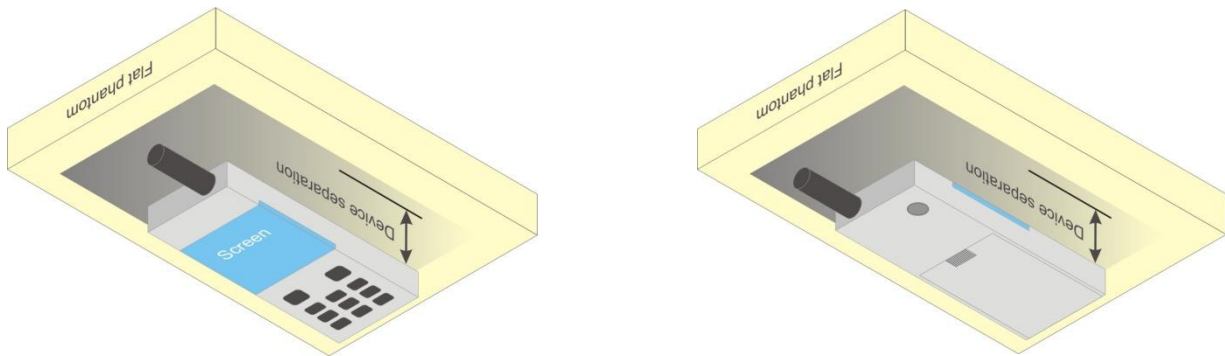

Fig-4.2 Illustration for Cheek Position
3. Tilted Position

- (a) To position the device in the “cheek” position described above.
- (b) While maintaining the device the reference plane described above and pivoting against the ear, moves it outward away from the mouth by an angle of 15 degrees or until contact with the ear is lost (see Fig-4.3).

Fig-4.3 Illustration for Tilted Position

4. Body Worn Position

- (a) To position the EUT parallel to the phantom surface.
- (b) To adjust the EUT parallel to the flat phantom.
- (c) To adjust the distance between the EUT surface and the flat phantom to 2.5 cm for body-worn, and 1.0 cm for hotspot mode.

**Fig-4.4 Illustration for Body Worn Position**



FCC SAR Test Report

4.3 Tissue Verification

The measuring results for tissue simulating liquid are shown as below.

Tissue Type	Frequency (MHz)	Liquid Temp. (°C)	Measured Conductivity (σ)	Measured Permittivity (ε _r)	Target Conductivity (σ)	Target Permittivity (ε _r)	Conductivity Deviation (%)	Permittivity Deviation (%)	Test Date
H750	750	20.6	0.908	40.492	0.89	41.9	2.02	-3.36	Sep. 03, 2012
H750	750	21.3	0.892	41.542	0.89	41.9	0.22	-0.85	Sep. 25, 2012
H750	750	21.5	0.885	40.053	0.89	41.9	-0.56	-4.41	Oct. 19, 2012
H835	835	20.9	0.916	42.727	0.90	41.5	1.78	2.96	Sep. 01, 2012
H835	835	20.6	0.917	42.809	0.90	41.5	1.89	3.15	Sep. 03, 2012
H835	835	21.2	0.897	41.95	0.90	41.5	-0.33	1.08	Sep. 25, 2012
H835	835	20.2	0.89	40.669	0.90	41.5	-1.11	-2.00	Oct. 16, 2012
H835	835	21.5	0.886	42.111	0.90	41.5	-1.56	1.47	Oct. 19, 2012
H1750	1750	20.8	1.342	41.827	1.37	40.1	-2.04	4.31	Sep. 01, 2012
H1750	1750	20.7	1.336	41.496	1.37	40.1	-2.48	3.48	Sep. 02, 2012
H1750	1750	21.2	1.335	41.503	1.37	40.1	-2.55	3.50	Sep. 25, 2012
H1750	1750	20.4	1.334	41.706	1.37	40.1	-2.63	4.00	Sep. 26, 2012
H1750	1750	20.2	1.332	39.686	1.37	40.1	-2.77	-1.03	Oct. 16, 2012
H1750	1750	21.6	1.347	39.767	1.37	40.1	-1.68	-0.83	Oct. 19, 2012
H1900	1900	20.8	1.437	39.739	1.40	40.0	2.64	-0.65	Sep. 01, 2012
H1900	1900	20.6	1.436	39.743	1.40	40.0	2.57	-0.64	Sep. 02, 2012
H1900	1900	20.4	1.436	39.743	1.40	40.0	2.57	-0.64	Sep. 26, 2012
H1900	1900	20.7	1.443	39.72	1.40	40.0	3.07	-0.70	Oct. 17, 2012
H1900	1900	21.4	1.424	40.347	1.40	40.0	1.71	0.87	Oct. 19, 2012
H2450	2450	20.3	1.774	40.267	1.80	39.2	-1.44	2.72	Sep. 11, 2012
H2450	2450	21.7	1.80	40.379	1.80	39.2	0.00	3.01	Oct. 02, 2012
B750	750	20.3	0.969	55.526	0.96	55.5	0.94	0.05	Sep. 07, 2012
B750	750	20.4	0.974	56.00	0.96	55.5	1.46	0.90	Sep. 21, 2012
B750	750	20.8	0.971	55.60	0.96	55.5	1.15	0.18	Sep. 26, 2012
B750	750	21.7	0.966	55.257	0.96	55.5	0.63	-0.44	Oct. 20, 2012
B835	835	21.5	0.973	55.201	0.97	55.2	0.31	0.00	Sep. 01, 2012
B835	835	20.2	0.977	55.586	0.97	55.2	0.72	0.70	Sep. 07, 2012
B835	835	20.6	0.98	55.935	0.97	55.2	1.03	1.33	Sep. 20, 2012
B835	835	20.3	0.98	55.80	0.97	55.2	1.03	1.09	Sep. 21, 2012
B835	835	20.9	0.98	55.935	0.97	55.2	1.03	1.33	Sep. 26, 2012
B835	835	20.1	0.992	56.671	0.97	55.2	2.27	2.66	Oct. 16, 2012
B1750	1750	20.9	1.468	53.825	1.49	53.4	-1.48	0.80	Sep. 01, 2012
B1750	1750	20.1	1.47	53.70	1.49	53.4	-1.34	0.56	Sep. 05, 2012
B1750	1750	21.3	1.52	54.60	1.49	53.4	2.01	2.25	Sep. 20, 2012
B1750	1750	20.4	1.47	53.682	1.49	53.4	-1.34	0.53	Sep. 24, 2012
B1750	1750	20.8	1.468	53.825	1.49	53.4	-1.48	0.80	Sep. 27, 2012
B1750	1750	21.7	1.462	54.519	1.49	53.4	-1.88	2.10	Oct. 18, 2012
B1900	1900	21.0	1.549	52.883	1.52	53.3	1.91	-0.78	Sep. 01, 2012
B1900	1900	20.1	1.54	52.80	1.52	53.3	1.32	-0.94	Sep. 05, 2012
B1900	1900	21.1	1.55	53.00	1.52	53.3	1.97	-0.56	Sep. 20, 2012
B1900	1900	20.4	1.535	52.012	1.52	53.3	0.99	-2.42	Sep. 24, 2012
B1900	1900	20.9	1.544	52.838	1.52	53.3	1.58	-0.87	Sep. 27, 2012
B1900	1900	21.5	1.545	53.003	1.52	53.3	1.64	-0.56	Oct. 18, 2012
B2450	2450	20.5	2.022	53.095	1.95	52.7	3.69	0.75	Sep. 11, 2012
B2450	2450	21.0	1.985	54.284	1.95	52.7	1.79	3.01	Sep. 27, 2012

Note:

The dielectric properties of the tissue simulating liquid must be measured within 24 hours before the SAR testing and within ±5% of the target values. Liquid temperature during the SAR testing must be within ±2 °C.



FCC SAR Test Report

4.4 System Verification

The measuring results for system check are shown as below.

Test Date	Mode	Frequency (MHz)	1W Target SAR-1g (W/kg)	Measured SAR-1g (W/kg)	Normalized to 1W SAR-1g (W/kg)	Deviation (%)	Dipole S/N	Probe S/N	DAE S/N
Sep. 03, 2012	Head	750	8.44	2.23	8.92	5.69	1013	3590	579
Sep. 25, 2012	Head	750	8.44	2.26	9.04	7.11	1013	3650	861
Oct. 19, 2012	Head	750	8.44	2.26	9.04	7.11	1013	3590	861
Sep. 01, 2012	Head	835	9.46	2.42	9.68	2.33	4d021	3650	910
Sep. 03, 2012	Head	835	9.46	2.43	9.72	2.75	4d021	3590	579
Sep. 25, 2012	Head	835	9.46	2.43	9.72	2.75	4d021	3650	861
Oct. 16, 2012	Head	835	9.46	2.36	9.44	-0.21	4d021	3864	579
Oct. 19, 2012	Head	835	9.46	2.35	9.40	-0.63	4d021	3590	861
Sep. 01, 2012	Head	1750	35.80	9.04	36.16	1.01	1023	3864	1277
Sep. 02, 2012	Head	1750	35.80	8.99	35.96	0.45	1023	3590	579
Sep. 25, 2012	Head	1750	35.80	8.80	35.20	-1.68	1023	3650	861
Sep. 26, 2012	Head	1750	35.80	9.25	37.00	3.35	1023	3650	861
Oct. 16, 2012	Head	1750	35.80	8.95	35.80	0.00	1023	3864	579
Oct. 19, 2012	Head	1750	35.80	9.05	36.20	1.12	1023	3864	579
Sep. 01, 2012	Head	1900	38.90	9.68	38.72	-0.46	5d036	3864	1277
Sep. 02, 2012	Head	1900	38.90	9.98	39.92	2.62	5d036	3590	579
Sep. 26, 2012	Head	1900	38.90	9.51	38.04	-2.21	5d036	3650	861
Oct. 17, 2012	Head	1900	38.90	9.53	38.12	-2.01	5d036	3864	579
Oct. 19, 2012	Head	1900	38.90	9.57	38.28	-1.59	5d036	3864	579
Sep. 11, 2012	Head	2450	52.90	13.9	55.60	5.10	737	3590	579
Oct. 02, 2012	Head	2450	52.90	13.1	52.40	-0.95	737	3864	861
Sep. 07, 2012	Body	750	8.76	2.32	9.28	5.94	1013	3650	910
Sep. 21, 2012	Body	750	8.76	2.34	9.36	6.85	1013	3650	861
Sep. 26, 2012	Body	750	8.76	2.14	8.56	-2.28	1013	3650	861
Oct. 20, 2012	Body	750	8.76	2.16	8.64	-1.37	1013	3590	861
Sep. 01, 2012	Body	835	9.60	2.39	9.56	-0.42	4d021	3650	910
Sep. 07, 2012	Body	835	9.60	2.38	9.52	-0.83	4d021	3864	1277
Sep. 20, 2012	Body	835	9.60	2.37	9.48	-1.25	4d021	3650	861
Sep. 21, 2012	Body	835	9.60	2.41	9.64	0.42	4d021	3650	861
Sep. 26, 2012	Body	835	9.60	2.41	9.64	0.42	4d021	3864	1277
Oct. 16, 2012	Body	835	9.60	2.44	9.76	1.67	4d021	3864	579
Sep. 01, 2012	Body	1750	37.00	8.99	35.96	-2.81	1023	3650	910
Sep. 05, 2012	Body	1750	37.00	9.48	37.92	2.49	1023	3864	1277
Sep. 20, 2012	Body	1750	37.00	9.64	38.56	4.22	1023	3864	1277
Sep. 24, 2012	Body	1750	37.00	9.04	36.16	-2.27	1023	3650	861
Sep. 27, 2012	Body	1750	37.00	9.39	37.56	1.51	1023	3864	1277
Oct. 18, 2012	Body	1750	37.00	9.42	37.68	1.84	1023	3864	579
Sep. 01, 2012	Body	1900	38.90	9.86	39.44	1.39	5d036	3650	910
Sep. 05, 2012	Body	1900	38.90	9.67	38.68	-0.57	5d036	3864	1277
Sep. 20, 2012	Body	1900	38.90	9.55	38.20	-1.80	5d036	3864	1277
Sep. 24, 2012	Body	1900	38.90	10.1	40.40	3.86	5d036	3650	861
Sep. 27, 2012	Body	1900	38.90	9.71	38.84	-0.15	5d036	3864	1277
Oct. 18, 2012	Body	1900	38.90	9.53	38.12	-2.01	5d036	3864	579
Sep. 11, 2012	Body	2450	50.00	12.3	49.20	-1.60	737	3590	579
Sep. 27, 2012	Body	2450	50.00	11.9	47.60	-4.80	737	3864	1277

Note:

Comparing to the reference SAR value provided by SPEAG, the validation data should be within its specification of 10 %. The result indicates the system check can meet the variation criterion and the plots can be referred to Appendix A of this report.



4.5 Conducted Power Results

The measuring conducted power (Unit: dBm) without power cutback provided from client are shown as below.

Band	CDMA2000 BC0			CDMA2000 BC1		
Channel	1013	384	777	25	600	1175
Frequency (MHz)	824.70	836.52	848.31	1851.25	1880.00	1908.75
1xRTT RC1+SO55	25.23	25.04	25.16	25.14	24.96	25.15
1xRTT RC3+SO55	25.19	25.00	25.11	25.18	25.02	25.15
1xRTT RC3+SO32 (FCH)	25.11	24.95	25.07	24.92	24.74	24.91
1xRTT RC3+SO32 (FCH+SCH)	25.10	24.92	25.04	24.90	24.76	24.93
1xEVDO Rev.0 (RTAP 153.6)	25.20	25.09	25.20	24.99	24.88	25.06
1xEVDO Rev.A (RETAP 4096)	25.04	24.91	25.05	24.89	24.74	24.87

Band	CDMA2000 BC15			-		
Channel	25	425	875	-	-	-
Frequency (MHz)	1711.25	1731.25	1753.75	-	-	-
1xRTT RC1+SO55	25.03	25.02	25.05	-	-	-
1xRTT RC3+SO55	25.16	25.20	25.22	-	-	-
1xRTT RC3+SO32 (FCH)	24.92	24.81	24.93	-	-	-
1xRTT RC3+SO32 (FCH+SCH)	24.90	24.83	24.92	-	-	-
1xEVDO Rev.0 (RTAP 153.6)	24.93	24.92	25.01	-	-	-
1xEVDO Rev.A (RETAP 4096)	24.85	24.74	24.81	-	-	-

Band	802.11b			802.11g		
Channel	1	6	11	1	6	11
Frequency (MHz)	2412	2437	2462	2412	2437	2462
Average Power	17.31	19.60	18.88	13.65	14.91	14.04

Band	802.11n (HT20)			802.11n (HT40)		
Channel	1	6	11	3	6	9
Frequency (MHz)	2412	2437	2462	2422	2437	2452
Average Power	12.73	14.93	13.95	11.57	13.56	11.52



FCC SAR Test Report

LTE Band 2									
BW	Modulation	CH	Frequency (MHz)	RB	RB Offset	Target Power	MPR	Measured Power	Reducing Power
5 MHz	QPSK	18625	1852.5	1	0	24	0	23.77	-0.23
		18900	1880	1	0	24	0	24.16	0.16
		19175	1907.5	1	0	24	0	24.05	0.05
		18625	1852.5	1	24	24	0	23.85	-0.15
		18900	1880	1	24	24	0	24.00	0.00
		19175	1907.5	1	24	24	0	24.01	0.01
		18625	1852.5	12	6	24	1	23.04	-0.96
		18900	1880	12	6	24	1	23.00	-1.00
		19175	1907.5	12	6	24	1	23.02	-0.98
		18625	1852.5	25	0	24	1	22.90	-1.10
	18900	1880	25	0	24	1	22.98	-1.02	
	19175	1907.5	25	0	24	1	22.98	-1.02	
	16QAM	18625	1852.5	1	0	24	1	22.77	-1.23
		18900	1880	1	0	24	1	23.19	-0.81
		19175	1907.5	1	0	24	1	23.23	-0.77
		18625	1852.5	1	24	24	1	22.91	-1.09
		18900	1880	1	24	24	1	22.72	-1.28
		19175	1907.5	1	24	24	1	23.27	-0.73
		18625	1852.5	12	6	24	2	22.13	-1.87
		18900	1880	12	6	24	2	22.06	-1.94
19175		1907.5	12	6	24	2	21.99	-2.01	
18625		1852.5	25	0	24	2	21.84	-2.16	
18900	1880	25	0	24	2	21.98	-2.02		
19175	1907.5	25	0	24	2	21.97	-2.03		
10 MHz	QPSK	18650	1855	1	0	24	0	23.89	-0.11
		18900	1880	1	0	24	0	24.08	0.08
		19150	1905	1	0	24	0	24.17	0.17
		18650	1855	1	49	24	0	23.96	-0.04
		18900	1880	1	49	24	0	23.99	-0.01
		19150	1905	1	49	24	0	24.18	0.18
		18650	1855	25	12	24	1	22.89	-1.11
		18900	1880	25	12	24	1	22.97	-1.03
		19150	1905	25	12	24	1	23.00	-1.00
		18650	1855	50	0	24	1	22.88	-1.12
		18900	1880	50	0	24	1	22.91	-1.09
		19150	1905	50	0	24	1	22.93	-1.07
	16QAM	18650	1855	1	0	24	1	22.87	-1.13
		18900	1880	1	0	24	1	23.06	-0.94
		19150	1905	1	0	24	1	23.29	-0.71
		18650	1855	1	49	24	1	22.86	-1.14
		18900	1880	1	49	24	1	23.11	-0.89
		19150	1905	1	49	24	1	23.17	-0.83
		18650	1855	25	12	24	2	21.98	-2.02
		18900	1880	25	12	24	2	22.02	-1.98
		19150	1905	25	12	24	2	22.05	-1.95
		18650	1855	50	0	24	2	22.01	-1.99
18900	1880	50	0	24	2	22.03	-1.97		
19150	1905	50	0	24	2	22.05	-1.95		



FCC SAR Test Report

A D T

LTE Band 4									
BW	Modulation	CH	Frequency (MHz)	RB	RB Offset	Target Power	MPR	Measured Power	Reducing Power
5 MHz	QPSK	19975	1712.5	1	0	24	0	24.33	0.33
		20175	1732.5	1	0	24	0	24.17	0.17
		20375	1752.5	1	0	24	0	23.99	-0.01
		19975	1712.5	1	24	24	0	24.25	0.25
		20175	1732.5	1	24	24	0	24.00	0.00
		20375	1752.5	1	24	24	0	23.84	-0.16
		19975	1712.5	12	6	24	0	23.10	-0.90
		20175	1732.5	12	6	24	0	22.95	-1.05
		20375	1752.5	12	6	24	0	23.19	-0.81
		19975	1712.5	25	0	24	0	22.78	-1.22
	20175	1732.5	25	0	24	0	22.80	-1.20	
	20375	1752.5	25	0	24	0	22.91	-1.09	
	16QAM	19975	1712.5	1	0	24	0	24.22	0.22
		20175	1732.5	1	0	24	0	24.12	0.12
		20375	1752.5	1	0	24	0	24.18	0.18
		19975	1712.5	1	24	24	0	24.18	0.18
		20175	1732.5	1	24	24	0	24.14	0.14
		20375	1752.5	1	24	24	0	24.12	0.12
		19975	1712.5	12	6	24	0	24.17	0.17
		20175	1732.5	12	6	24	0	23.98	-0.02
20375		1752.5	12	6	24	0	24.18	0.18	
19975		1712.5	25	0	24	0	23.94	-0.06	
20175	1732.5	25	0	24	0	23.91	-0.09		
20375	1752.5	25	0	24	0	23.97	-0.03		
10 MHz	QPSK	20000	1715	1	0	24	0	24.40	0.40
		20175	1732.5	1	0	24	0	24.34	0.34
		20350	1750	1	0	24	0	24.28	0.28
		20000	1715	1	49	24	0	24.38	0.38
		20175	1732.5	1	49	24	0	24.21	0.21
		20350	1750	1	49	24	0	24.16	0.16
		20000	1715	25	12	24	0	24.00	0.00
		20175	1732.5	25	12	24	0	23.96	-0.04
		20350	1750	25	12	24	0	23.88	-0.12
		20000	1715	50	0	24	0	23.89	-0.11
		20175	1732.5	50	0	24	0	23.79	-0.21
		20350	1750	50	0	24	0	23.69	-0.31
	16QAM	20000	1715	1	0	24	0	24.22	0.22
		20175	1732.5	1	0	24	0	24.13	0.13
		20350	1750	1	0	24	0	24.01	0.01
		20000	1715	1	49	24	0	24.31	0.31
		20175	1732.5	1	49	24	0	24.30	0.30
		20350	1750	1	49	24	0	24.22	0.22
		20000	1715	25	12	24	1	23.00	-1.00
		20175	1732.5	25	12	24	1	22.83	-1.17
		20350	1750	25	12	24	1	22.73	-1.27
		20000	1715	50	0	24	1	22.87	-1.13
20175	1732.5	50	0	24	1	22.79	-1.21		
20350	1750	50	0	24	1	22.71	-1.29		



FCC SAR Test Report

A D T

LTE Band 5									
BW	Modulation	CH	Frequency (MHz)	RB	RB Offset	Target Power	MPR	Measured Power	Reducing Power
5 MHz	QPSK	20425	826.5	1	0	24	0	23.99	-0.01
		20525	836.5	1	0	24	0	23.85	-0.15
		20625	846.5	1	0	24	0	23.86	-0.14
		20425	826.5	1	24	24	0	23.88	-0.12
		20525	836.5	1	24	24	0	23.91	-0.09
		20625	846.5	1	24	24	0	23.99	-0.01
		20425	826.5	12	6	24	1	23.29	-0.71
		20525	836.5	12	6	24	1	23.17	-0.83
		20625	846.5	12	6	24	1	23.31	-0.69
		20425	826.5	25	0	24	1	23.18	-0.82
	20525	836.5	25	0	24	1	23.08	-0.92	
	20625	846.5	25	0	24	1	23.19	-0.81	
	16QAM	20425	826.5	1	0	24	1	23.40	-0.60
		20525	836.5	1	0	24	1	23.03	-0.97
		20625	846.5	1	0	24	1	23.36	-0.64
		20425	826.5	1	24	24	1	23.32	-0.68
		20525	836.5	1	24	24	1	23.08	-0.92
		20625	846.5	1	24	24	1	23.42	-0.58
		20425	826.5	12	6	24	2	22.22	-1.78
		20525	836.5	12	6	24	2	22.12	-1.88
20625		846.5	12	6	24	2	22.28	-1.72	
20425		826.5	25	0	24	2	22.23	-1.77	
20525	836.5	25	0	24	2	22.08	-1.92		
20625	846.5	25	0	24	2	22.26	-1.74		
10 MHz	QPSK	20450	829	1	0	24	0	24.00	0.00
		20525	836.5	1	0	24	0	23.83	-0.17
		20600	844	1	0	24	0	23.85	-0.15
		20450	829	1	49	24	0	23.99	-0.01
		20525	836.5	1	49	24	0	23.79	-0.21
		20600	844	1	49	24	0	23.87	-0.13
		20450	829	25	12	24	1	23.06	-0.94
		20525	836.5	25	12	24	1	23.05	-0.95
		20600	844	25	12	24	1	23.09	-0.91
		20450	829	50	0	24	1	23.03	-0.97
	20525	836.5	50	0	24	1	22.99	-1.01	
	20600	844	50	0	24	1	23.00	-1.00	
	16QAM	20450	829	1	0	24	1	23.44	-0.56
		20525	836.5	1	0	24	1	23.33	-0.67
		20600	844	1	0	24	1	23.38	-0.62
		20450	829	1	49	24	1	23.29	-0.71
		20525	836.5	1	49	24	1	23.25	-0.75
		20600	844	1	49	24	1	23.28	-0.72
		20450	829	25	12	24	2	22.08	-1.92
		20525	836.5	25	12	24	2	22.04	-1.96
20600		844	25	12	24	2	22.06	-1.94	
20450		829	50	0	24	2	22.16	-1.84	
20525	836.5	50	0	24	2	21.93	-2.07		
20600	844	50	0	24	2	22.06	-1.94		



FCC SAR Test Report

A D T

LTE Band 12									
BW	Modulation	CH	Frequency (MHz)	RB	RB Offset	Target Power	MPR	Measured Power	Reducing Power
5 MHz	QPSK	23035	701.5	1	0	24	0	23.89	-0.11
		23095	707.5	1	0	24	0	24.01	0.01
		23155	713.5	1	0	24	0	24.36	0.36
		23035	701.5	1	24	24	0	24.10	0.10
		23095	707.5	1	24	24	0	23.95	-0.05
		23155	713.5	1	24	24	0	24.04	0.04
		23035	701.5	12	6	24	0	23.91	-0.09
		23095	707.5	12	6	24	0	23.93	-0.07
		23155	713.5	12	6	24	0	24.15	0.15
		23035	701.5	25	0	24	0	23.75	-0.25
	23095	707.5	25	0	24	0	23.76	-0.24	
	23155	713.5	25	0	24	0	24.05	0.05	
	16QAM	23035	701.5	1	0	24	0	23.95	-0.05
		23095	707.5	1	0	24	0	24.15	0.15
		23155	713.5	1	0	24	0	24.12	0.12
		23035	701.5	1	24	24	0	24.04	0.04
		23095	707.5	1	24	24	0	23.97	-0.03
		23155	713.5	1	24	24	0	23.76	-0.24
		23035	701.5	12	6	24	0	23.86	-0.14
		23095	707.5	12	6	24	0	23.88	-0.12
23155		713.5	12	6	24	0	24.20	0.20	
23035		701.5	25	0	24	0	23.74	-0.26	
23095	707.5	25	0	24	0	23.80	-0.20		
23155	713.5	25	0	24	0	23.99	-0.01		
10 MHz	QPSK	23060	704 MHz	1	0	24	0	23.97	-0.03
		23095	707.5 MHz	1	0	24	0	23.90	-0.10
		23130	711 MHz	1	0	24	0	24.08	0.08
		23060	704 MHz	1	49	24	0	24.36	0.36
		23095	707.5 MHz	1	49	24	0	24.33	0.33
		23130	711 MHz	1	49	24	0	24.39	0.39
		23060	704 MHz	25	12	24	0	23.80	-0.20
		23095	707.5 MHz	25	12	24	0	23.79	-0.21
		23130	711 MHz	25	12	24	0	23.84	-0.16
		23060	704 MHz	50	0	24	0	23.75	-0.25
	23095	707.5 MHz	50	0	24	0	23.73	-0.27	
	23130	711 MHz	50	0	24	0	23.76	-0.24	
	16QAM	23060	704 MHz	1	0	24	0	23.87	-0.13
		23095	707.5 MHz	1	0	24	0	23.71	-0.29
		23130	711 MHz	1	0	24	0	24.03	0.03
		23060	704 MHz	1	49	24	0	24.10	0.10
		23095	707.5 MHz	1	49	24	0	24.00	0.00
		23130	711 MHz	1	49	24	0	24.18	0.18
		23060	704 MHz	25	12	24	0	23.75	-0.25
		23095	707.5 MHz	25	12	24	0	23.72	-0.28
23130		711 MHz	25	12	24	0	23.81	-0.19	
23060		704 MHz	50	0	24	0	23.65	-0.35	
23095	707.5 MHz	50	0	24	0	23.62	-0.38		
23130	711 MHz	50	0	24	0	23.67	-0.33		



FCC SAR Test Report

A D T

LTE Band 25									
BW	Modulation	CH	Frequency (MHz)	RB	RB Offset	Target Power	MPR	Measured Power	Reducing Power
5 MHz	QPSK	23755	1852.5	1	0	24	0	24.05	0.05
		23790	1882.5	1	0	24	0	24.17	0.17
		23825	1912.5	1	0	24	0	24.02	0.02
		23755	1852.5	1	24	24	0	23.98	-0.02
		23790	1882.5	1	24	24	0	24.13	0.13
		23825	1912.5	1	24	24	0	23.85	-0.15
		23755	1852.5	12	6	24	1	23.04	-0.96
		23790	1882.5	12	6	24	1	23.08	-0.92
		23825	1912.5	12	6	24	1	23.07	-0.93
		23755	1852.5	25	0	24	1	22.95	-1.05
	23790	1882.5	25	0	24	1	23.05	-0.95	
	23825	1912.5	25	0	24	1	22.94	-1.06	
	16QAM	23755	1852.5	1	0	24	1	22.97	-1.03
		23790	1882.5	1	0	24	1	22.89	-1.11
		23825	1912.5	1	0	24	1	23.22	-0.78
		23755	1852.5	1	24	24	1	22.78	-1.22
		23790	1882.5	1	24	24	1	23.29	-0.71
		23825	1912.5	1	24	24	1	23.00	-1.00
		23755	1852.5	12	6	24	2	22.01	-1.99
		23790	1882.5	12	6	24	2	22.18	-1.82
23825		1912.5	12	6	24	2	21.99	-2.01	
23755		1852.5	25	0	24	2	21.99	-2.01	
23790	1882.5	25	0	24	2	22.13	-1.87		
23825	1912.5	25	0	24	2	21.96	-2.04		
10 MHz	QPSK	26090	1855	1	0	24	0	23.83	-0.17
		26365	1882.5	1	0	24	0	24.18	0.18
		26640	1910	1	0	24	0	23.96	-0.04
		26090	1855	1	49	24	0	23.89	-0.11
		26365	1882.5	1	49	24	0	24.19	0.19
		26640	1910	1	49	24	0	23.90	-0.10
		26090	1855	25	12	24	1	22.90	-1.10
		26365	1882.5	25	12	24	1	22.96	-1.04
		26640	1910	25	12	24	1	22.92	-1.08
		26090	1855	50	0	24	1	22.83	-1.17
	26365	1882.5	50	0	24	1	22.95	-1.05	
	26640	1910	50	0	24	1	22.88	-1.12	
	16QAM	26090	1855	1	0	24	1	23.07	-0.93
		26365	1882.5	1	0	24	1	23.26	-0.74
		26640	1910	1	0	24	1	23.12	-0.88
		26090	1855	1	49	24	1	23.05	-0.95
		26365	1882.5	1	49	24	1	23.18	-0.82
		26640	1910	1	49	24	1	23.09	-0.91
		26090	1855	25	12	24	2	21.89	-2.11
		26365	1882.5	25	12	24	2	22.05	-1.95
26640		1910	25	12	24	2	21.96	-2.04	
26090		1855	50	0	24	2	21.83	-2.17	
26365	1882.5	50	0	24	2	21.99	-2.01		
26640	1910	50	0	24	2	21.87	-2.13		



FCC SAR Test Report

4.6 SAR Testing Results

4.6.1 SAR Results for Head

Plot No.	Band	Mode	Test Position	Channel	Cutback Power	SAR-1g (W/kg)
7	CDMA BC0	RC3+SO55	Right Cheek	1013	0	0.808
8	CDMA BC0	RC3+SO55	Right Tilted	1013	0	0.418
9	CDMA BC0	RC3+SO55	Left Cheek	1013	0	0.817
10	CDMA BC0	RC3+SO55	Left Tilted	1013	0	0.494
19	CDMA BC0	RC3+SO55	Right Cheek	384	0	0.871
20	CDMA BC0	RC3+SO55	Right Cheek	777	0	1.02
22	CDMA BC0	RC3+SO55	Left Cheek	384	0	0.913
23	CDMA BC0	RC3+SO55	Left Cheek	777	0	1.08
24	CDMA BC1	RC3+SO55	Right Cheek	25	0	0.621
12	CDMA BC1	RC3+SO55	Right Tilted	25	0	0.162
13	CDMA BC1	RC3+SO55	Left Cheek	25	0	0.33
14	CDMA BC1	RC3+SO55	Left Tilted	25	0	0.191
45	CDMA BC1	RC3+SO55	Right Cheek	25	-7.5	0.168
46	CDMA BC1	RC3+SO55	Right Tilted	25	-7.5	0.048
47	CDMA BC1	RC3+SO55	Left Cheek	25	-7.5	0.148
48	CDMA BC1	RC3+SO55	Left Tilted	25	-7.5	0.035
25	CDMA BC15	RC3+SO55	Right Cheek	875	0	0.577
16	CDMA BC15	RC3+SO55	Right Tilted	875	0	0.285
17	CDMA BC15	RC3+SO55	Left Cheek	875	0	0.66
18	CDMA BC15	RC3+SO55	Left Tilted	875	0	0.327
49	CDMA BC15	RC3+SO55	Right Cheek	875	-7.5	0.221
50	CDMA BC15	RC3+SO55	Right Tilted	875	-7.5	0.048
51	CDMA BC15	RC3+SO55	Left Cheek	875	-7.5	0.146
52	CDMA BC15	RC3+SO55	Left Tilted	875	-7.5	0.051



FCC SAR Test Report

Plot No.	Band	Mode	Test Position	Channel	RB	RB Offset	Cutback Power	SAR-1g (W/kg)
218	LTE 2	QPSK_10M	Right Cheek	19150	25	12	0	0.294
219	LTE 2	QPSK_10M	Right Tilted	19150	25	12	0	0.377
220	LTE 2	QPSK_10M	Left Cheek	19150	25	12	0	0.37
221	LTE 2	QPSK_10M	Left Tilted	19150	25	12	0	0.293
222	LTE 2	QPSK_10M	Right Cheek	19150	1	0	0	0.387
223	LTE 2	QPSK_10M	Right Tilted	19150	1	0	0	0.438
224	LTE 2	QPSK_10M	Left Cheek	19150	1	0	0	0.417
225	LTE 2	QPSK_10M	Left Tilted	19150	1	0	0	0.287
226	LTE 2	QPSK_10M	Right Cheek	19150	1	49	0	0.363
227	LTE 2	QPSK_10M	Right Tilted	19150	1	49	0	0.514
228	LTE 2	QPSK_10M	Left Cheek	19150	1	49	0	0.26
229	LTE 2	QPSK_10M	Left Tilted	19150	1	49	0	0.294
1148	LTE 2	16QAM_10M	Right Cheek	19150	25	12	0	0.184
231	LTE 2	16QAM_10M	Right Tilted	19150	25	12	0	0.331
1149	LTE 2	16QAM_10M	Left Cheek	19150	25	12	0	0.197
1150	LTE 2	16QAM_10M	Left Tilted	19150	25	12	0	0.204
1151	LTE 2	16QAM_10M	Right Cheek	19150	1	0	0	0.199
232	LTE 2	16QAM_10M	Right Tilted	19150	1	0	0	0.361
1152	LTE 2	16QAM_10M	Left Cheek	19150	1	0	0	0.21
1153	LTE 2	16QAM_10M	Left Tilted	19150	1	0	0	0.216
1154	LTE 2	16QAM_10M	Right Cheek	19150	1	49	0	0.19
233	LTE 2	16QAM_10M	Right Tilted	19150	1	49	0	0.421
1155	LTE 2	16QAM_10M	Left Cheek	19150	1	49	0	0.206
1156	LTE 2	16QAM_10M	Left Tilted	19150	1	49	0	0.206
1020	LTE 2	QPSK_10M	Right Cheek	19150	25	12	-5	0.191
1021	LTE 2	QPSK_10M	Right Tilted	19150	25	12	-5	0.223
1022	LTE 2	QPSK_10M	Left Cheek	19150	25	12	-5	0.219
1023	LTE 2	QPSK_10M	Left Tilted	19150	25	12	-5	0.177
1024	LTE 2	QPSK_10M	Right Cheek	19150	1	0	-5	0.201
1025	LTE 2	QPSK_10M	Right Tilted	19150	1	0	-5	0.221
1026	LTE 2	QPSK_10M	Left Cheek	19150	1	0	-5	0.211
1027	LTE 2	QPSK_10M	Left Tilted	19150	1	0	-5	0.189
413	LTE 2	QPSK_10M	Right Cheek	19150	1	49	-5	0.197
414	LTE 2	QPSK_10M	Right Tilted	19150	1	49	-5	0.232
415	LTE 2	QPSK_10M	Left Cheek	19150	1	49	-5	0.209
416	LTE 2	QPSK_10M	Left Tilted	19150	1	49	-5	0.18
1036	LTE 2	16QAM_10M	Right Cheek	19150	25	12	-5	0.226
1037	LTE 2	16QAM_10M	Right Tilted	19150	25	12	-5	0.236
1038	LTE 2	16QAM_10M	Left Cheek	19150	25	12	-5	0.193
1039	LTE 2	16QAM_10M	Left Tilted	19150	25	12	-5	0.142
1040	LTE 2	16QAM_10M	Right Cheek	19150	1	0	-5	0.21
1041	LTE 2	16QAM_10M	Right Tilted	19150	1	0	-5	0.248
1042	LTE 2	16QAM_10M	Left Cheek	19150	1	0	-5	0.18
1043	LTE 2	16QAM_10M	Left Tilted	19150	1	0	-5	0.144
1044	LTE 2	16QAM_10M	Right Cheek	19150	1	49	-5	0.189
1045	LTE 2	16QAM_10M	Right Tilted	19150	1	49	-5	0.252
1046	LTE 2	16QAM_10M	Left Cheek	19150	1	49	-5	0.203
1047	LTE 2	16QAM_10M	Left Tilted	19150	1	49	-5	0.12



FCC SAR Test Report

Plot No.	Band	Mode	Test Position	Channel	RB	RB Offset	Cutback Power	SAR-1g (W/kg)
201	LTE 4	QPSK_10M	Right Cheek	20000	25	12	0	0.253
202	LTE 4	QPSK_10M	Right Tilted	20000	25	12	0	0.356
203	LTE 4	QPSK_10M	Left Cheek	20000	25	12	0	0.268
204	LTE 4	QPSK_10M	Left Tilted	20000	25	12	0	0.333
205	LTE 4	QPSK_10M	Right Cheek	20000	1	0	0	0.317
206	LTE 4	QPSK_10M	Right Tilted	20000	1	0	0	0.479
207	LTE 4	QPSK_10M	Left Cheek	20000	1	0	0	0.227
208	LTE 4	QPSK_10M	Left Tilted	20000	1	0	0	0.273
209	LTE 4	QPSK_10M	Right Cheek	20000	1	49	0	0.690
210	LTE 4	QPSK_10M	Right Tilted	20000	1	49	0	0.532
211	LTE 4	QPSK_10M	Left Cheek	20000	1	49	0	0.365
212	LTE 4	QPSK_10M	Left Tilted	20000	1	49	0	0.428
215	LTE 4	16QAM_10M	Right Cheek	20000	25	12	0	0.202
1139	LTE 4	16QAM_10M	Right Tilted	20000	25	12	0	0.392
1140	LTE 4	16QAM_10M	Left Cheek	20000	25	12	0	0.281
1141	LTE 4	16QAM_10M	Left Tilted	20000	25	12	0	0.347
216	LTE 4	16QAM_10M	Right Cheek	20000	1	0	0	0.268
1142	LTE 4	16QAM_10M	Right Tilted	20000	1	0	0	0.41
1143	LTE 4	16QAM_10M	Left Cheek	20000	1	0	0	0.286
1144	LTE 4	16QAM_10M	Left Tilted	20000	1	0	0	0.361
217	LTE 4	16QAM_10M	Right Cheek	20000	1	49	0	0.286
1145	LTE 4	16QAM_10M	Right Tilted	20000	1	49	0	0.401
1146	LTE 4	16QAM_10M	Left Cheek	20000	1	49	0	0.287
1147	LTE 4	16QAM_10M	Left Tilted	20000	1	49	0	0.353
1012	LTE 4	QPSK_10M	Right Cheek	20000	25	12	-5	0.179
1013	LTE 4	QPSK_10M	Right Tilted	20000	25	12	-5	0.281
1014	LTE 4	QPSK_10M	Left Cheek	20000	25	12	-5	0.194
1015	LTE 4	QPSK_10M	Left Tilted	20000	25	12	-5	0.233
1016	LTE 4	QPSK_10M	Right Cheek	20000	1	0	-5	0.232
1017	LTE 4	QPSK_10M	Right Tilted	20000	1	0	-5	0.361
1018	LTE 4	QPSK_10M	Left Cheek	20000	1	0	-5	0.247
1019	LTE 4	QPSK_10M	Left Tilted	20000	1	0	-5	0.299
409	LTE 4	QPSK_10M	Right Cheek	20000	1	49	-5	0.294
410	LTE 4	QPSK_10M	Right Tilted	20000	1	49	-5	0.427
411	LTE 4	QPSK_10M	Left Cheek	20000	1	49	-5	0.34
412	LTE 4	QPSK_10M	Left Tilted	20000	1	49	-5	0.413
477	LTE 4	16QAM_10M	Right Cheek	20000	25	12	-5	0.14
478	LTE 4	16QAM_10M	Right Tilted	20000	25	12	-5	0.224
479	LTE 4	16QAM_10M	Left Cheek	20000	25	12	-5	0.152
480	LTE 4	16QAM_10M	Left Tilted	20000	25	12	-5	0.185
481	LTE 4	16QAM_10M	Right Cheek	20000	1	0	-5	0.174
482	LTE 4	16QAM_10M	Right Tilted	20000	1	0	-5	0.277
483	LTE 4	16QAM_10M	Left Cheek	20000	1	0	-5	0.193
484	LTE 4	16QAM_10M	Left Tilted	20000	1	0	-5	0.232
485	LTE 4	16QAM_10M	Right Cheek	20000	1	49	-5	0.194
486	LTE 4	16QAM_10M	Right Tilted	20000	1	49	-5	0.311
487	LTE 4	16QAM_10M	Left Cheek	20000	1	49	-5	0.219
488	LTE 4	16QAM_10M	Left Tilted	20000	1	49	-5	0.266



FCC SAR Test Report

Plot No.	Band	Mode	Test Position	Channel	RB	RB Offset	Cutback Power	SAR-1g (W/kg)
266	LTE 5	QPSK_10M	Right Cheek	20450	25	12	0	0.724
267	LTE 5	QPSK_10M	Right Tilted	20450	25	12	0	0.542
268	LTE 5	QPSK_10M	Left Cheek	20450	25	12	0	0.534
269	LTE 5	QPSK_10M	Left Tilted	20450	25	12	0	0.406
270	LTE 5	QPSK_10M	Right Cheek	20450	1	0	0	0.878
271	LTE 5	QPSK_10M	Right Tilted	20450	1	0	0	0.71
272	LTE 5	QPSK_10M	Left Cheek	20450	1	0	0	0.702
273	LTE 5	QPSK_10M	Left Tilted	20450	1	0	0	0.53
274	LTE 5	QPSK_10M	Right Cheek	20450	1	49	0	1.05
275	LTE 5	QPSK_10M	Right Tilted	20450	1	49	0	0.767
276	LTE 5	QPSK_10M	Left Cheek	20450	1	49	0	0.776
277	LTE 5	QPSK_10M	Left Tilted	20450	1	49	0	0.583
278	LTE 5	16QAM_10M	Right Cheek	20450	25	12	0	0.587
1185	LTE 5	16QAM_10M	Right Tilted	20450	25	12	0	0.431
1167	LTE 5	16QAM_10M	Left Cheek	20450	25	12	0	0.618
1168	LTE 5	16QAM_10M	Left Tilted	20450	25	12	0	0.438
279	LTE 5	16QAM_10M	Right Cheek	20450	1	0	0	0.767
1186	LTE 5	16QAM_10M	Right Tilted	20450	1	0	0	0.571
1170	LTE 5	16QAM_10M	Left Cheek	20450	1	0	0	0.681
1171	LTE 5	16QAM_10M	Left Tilted	20450	1	0	0	0.572
280	LTE 5	16QAM_10M	Right Cheek	20450	1	49	0	0.847
1187	LTE 5	16QAM_10M	Right Tilted	20450	1	49	0	0.606
1173	LTE 5	16QAM_10M	Left Cheek	20450	1	49	0	0.747
1174	LTE 5	16QAM_10M	Left Tilted	20450	1	49	0	0.627
1002	LTE 5	QPSK_10M	Right Cheek	20450	25	12	-5	0.296
1003	LTE 5	QPSK_10M	Right Tilted	20450	25	12	-5	0.228
1004	LTE 5	QPSK_10M	Left Cheek	20450	25	12	-5	0.363
1005	LTE 5	QPSK_10M	Left Tilted	20450	25	12	-5	0.267
1006	LTE 5	QPSK_10M	Right Cheek	20450	1	0	-5	0.306
1007	LTE 5	QPSK_10M	Right Tilted	20450	1	0	-5	0.241
1008	LTE 5	QPSK_10M	Left Cheek	20450	1	0	-5	0.234
1009	LTE 5	QPSK_10M	Left Tilted	20450	1	0	-5	0.186
405	LTE 5	QPSK_10M	Right Cheek	20450	1	49	-5	0.409
406	LTE 5	QPSK_10M	Right Tilted	20450	1	49	-5	0.303
407	LTE 5	QPSK_10M	Left Cheek	20450	1	49	-5	0.282
408	LTE 5	QPSK_10M	Left Tilted	20450	1	49	-5	0.206
463	LTE 5	16QAM_10M	Right Cheek	20450	25	12	-5	0.247
464	LTE 5	16QAM_10M	Right Tilted	20450	25	12	-5	0.168
465	LTE 5	16QAM_10M	Left Cheek	20450	25	12	-5	0.342
466	LTE 5	16QAM_10M	Left Tilted	20450	25	12	-5	0.241
467	LTE 5	16QAM_10M	Right Cheek	20450	1	0	-5	0.253
468	LTE 5	16QAM_10M	Right Tilted	20450	1	0	-5	0.162
469	LTE 5	16QAM_10M	Left Cheek	20450	1	0	-5	0.205
470	LTE 5	16QAM_10M	Left Tilted	20450	1	0	-5	0.166
471	LTE 5	16QAM_10M	Right Cheek	20450	1	49	-5	0.489
472	LTE 5	16QAM_10M	Right Tilted	20450	1	49	-5	0.369
473	LTE 5	16QAM_10M	Left Cheek	20450	1	49	-5	0.408
474	LTE 5	16QAM_10M	Left Tilted	20450	1	49	-5	0.297



FCC SAR Test Report

Plot No.	Band	Mode	Test Position	Channel	RB	RB Offset	Cutback Power	SAR-1g (W/kg)
250	LTE 12	QPSK_10M	Right Cheek	23130	25	12	0	0.288
251	LTE 12	QPSK_10M	Right Tilted	23130	25	12	0	0.112
252	LTE 12	QPSK_10M	Left Cheek	23130	25	12	0	0.307
253	LTE 12	QPSK_10M	Left Tilted	23130	25	12	0	0.213
254	LTE 12	QPSK_10M	Right Cheek	23130	1	0	0	0.548
255	LTE 12	QPSK_10M	Right Tilted	23130	1	0	0	0.205
256	LTE 12	QPSK_10M	Left Cheek	23130	1	0	0	0.582
257	LTE 12	QPSK_10M	Left Tilted	23130	1	0	0	0.352
258	LTE 12	QPSK_10M	Right Cheek	23130	1	49	0	0.331
259	LTE 12	QPSK_10M	Right Tilted	23130	1	49	0	0.146
260	LTE 12	QPSK_10M	Left Cheek	23130	1	49	0	0.343
261	LTE 12	QPSK_10M	Left Tilted	23130	1	49	0	0.245
1175	LTE 12	16QAM_10M	Right Cheek	23130	25	12	0	0.259
1176	LTE 12	16QAM_10M	Right Tilted	23130	25	12	0	0.11
263	LTE 12	16QAM_10M	Left Cheek	23130	25	12	0	0.252
1177	LTE 12	16QAM_10M	Left Tilted	23130	25	12	0	0.113
1178	LTE 12	16QAM_10M	Right Cheek	23130	1	0	0	0.473
1179	LTE 12	16QAM_10M	Right Tilted	23130	1	0	0	0.206
264	LTE 12	16QAM_10M	Left Cheek	23130	1	0	0	0.446
1180	LTE 12	16QAM_10M	Left Tilted	23130	1	0	0	0.21
1181	LTE 12	16QAM_10M	Right Cheek	23130	1	49	0	0.251
1182	LTE 12	16QAM_10M	Right Tilted	23130	1	49	0	0.138
265	LTE 12	16QAM_10M	Left Cheek	23130	1	49	0	0.255
1183	LTE 12	16QAM_10M	Left Tilted	23130	1	49	0	0.113
1308	LTE 12	QPSK_10M	Right Cheek	23130	25	12	-5	0.271
1302	LTE 12	QPSK_10M	Right Tilted	23130	25	12	-5	0.116
1303	LTE 12	QPSK_10M	Left Cheek	23130	25	12	-5	0.229
1304	LTE 12	QPSK_10M	Left Tilted	23130	25	12	-5	0.11
401	LTE 12	QPSK_10M	Right Cheek	23130	1	0	-5	0.208
402	LTE 12	QPSK_10M	Right Tilted	23130	1	0	-5	0.146
403	LTE 12	QPSK_10M	Left Cheek	23130	1	0	-5	0.312
404	LTE 12	QPSK_10M	Left Tilted	23130	1	0	-5	0.158
1305	LTE 12	QPSK_10M	Right Cheek	23130	1	49	-5	0.249
1306	LTE 12	QPSK_10M	Right Tilted	23130	1	49	-5	0.125
1309	LTE 12	QPSK_10M	Left Cheek	23130	1	49	-5	0.299
1310	LTE 12	QPSK_10M	Left Tilted	23130	1	49	-5	0.155
1060	LTE 12	16QAM_10M	Right Cheek	23130	25	12	-5	0.209
1061	LTE 12	16QAM_10M	Right Tilted	23130	25	12	-5	0.081
1062	LTE 12	16QAM_10M	Left Cheek	23130	25	12	-5	0.173
1063	LTE 12	16QAM_10M	Left Tilted	23130	25	12	-5	0.075
1064	LTE 12	16QAM_10M	Right Cheek	23130	1	0	-5	0.195
1065	LTE 12	16QAM_10M	Right Tilted	23130	1	0	-5	0.096
1066	LTE 12	16QAM_10M	Left Cheek	23130	1	0	-5	0.202
1067	LTE 12	16QAM_10M	Left Tilted	23130	1	0	-5	0.086
1068	LTE 12	16QAM_10M	Right Cheek	23130	1	49	-5	0.202
1069	LTE 12	16QAM_10M	Right Tilted	23130	1	49	-5	0.105
1070	LTE 12	16QAM_10M	Left Cheek	23130	1	49	-5	0.205
1071	LTE 12	16QAM_10M	Left Tilted	23130	1	49	-5	0.087



FCC SAR Test Report

Plot No.	Band	Mode	Test Position	Channel	RB	RB Offset	Cutback Power	SAR-1g (W/kg)
234	LTE 25	QPSK_10M	Right Cheek	26365	25	12	0	0.264
235	LTE 25	QPSK_10M	Right Tilted	26365	25	12	0	0.377
236	LTE 25	QPSK_10M	Left Cheek	26365	25	12	0	0.285
237	LTE 25	QPSK_10M	Left Tilted	26365	25	12	0	0.301
238	LTE 25	QPSK_10M	Right Cheek	26365	1	0	0	0.301
239	LTE 25	QPSK_10M	Right Tilted	26365	1	0	0	0.459
240	LTE 25	QPSK_10M	Left Cheek	26365	1	0	0	0.339
241	LTE 25	QPSK_10M	Left Tilted	26365	1	0	0	0.354
242	LTE 25	QPSK_10M	Right Cheek	26365	1	49	0	0.415
243	LTE 25	QPSK_10M	Right Tilted	26365	1	49	0	0.624
244	LTE 25	QPSK_10M	Left Cheek	26365	1	49	0	0.465
245	LTE 25	QPSK_10M	Left Tilted	26365	1	49	0	0.486
1157	LTE 25	16QAM_10M	Right Cheek	26365	25	12	0	0.194
247	LTE 25	16QAM_10M	Right Tilted	26365	25	12	0	0.3
1158	LTE 25	16QAM_10M	Left Cheek	26365	25	12	0	0.221
1159	LTE 25	16QAM_10M	Left Tilted	26365	25	12	0	0.218
1160	LTE 25	16QAM_10M	Right Cheek	26365	1	0	0	0.191
248	LTE 25	16QAM_10M	Right Tilted	26365	1	0	0	0.361
1161	LTE 25	16QAM_10M	Left Cheek	26365	1	0	0	0.204
1162	LTE 25	16QAM_10M	Left Tilted	26365	1	0	0	0.217
1163	LTE 25	16QAM_10M	Right Cheek	26365	1	49	0	0.212
249	LTE 25	16QAM_10M	Right Tilted	26365	1	49	0	0.464
1164	LTE 25	16QAM_10M	Left Cheek	26365	1	49	0	0.227
1165	LTE 25	16QAM_10M	Left Tilted	26365	1	49	0	0.239
1028	LTE 25	QPSK_10M	Right Cheek	26365	25	12	-5	0.201
1029	LTE 25	QPSK_10M	Right Tilted	26365	25	12	-5	0.263
1030	LTE 25	QPSK_10M	Left Cheek	26365	25	12	-5	0.215
1031	LTE 25	QPSK_10M	Left Tilted	26365	25	12	-5	0.228
1032	LTE 25	QPSK_10M	Right Cheek	26365	1	0	-5	0.196
1033	LTE 25	QPSK_10M	Right Tilted	26365	1	0	-5	0.256
1034	LTE 25	QPSK_10M	Left Cheek	26365	1	0	-5	0.211
1035	LTE 25	QPSK_10M	Left Tilted	26365	1	0	-5	0.229
417	LTE 25	QPSK_10M	Right Cheek	26365	1	49	-5	0.204
418	LTE 25	QPSK_10M	Right Tilted	26365	1	49	-5	0.322
419	LTE 25	QPSK_10M	Left Cheek	26365	1	49	-5	0.315
420	LTE 25	QPSK_10M	Left Tilted	26365	1	49	-5	0.293
1048	LTE 25	16QAM_10M	Right Cheek	26365	25	12	-5	0.185
1049	LTE 25	16QAM_10M	Right Tilted	26365	25	12	-5	0.238
1050	LTE 25	16QAM_10M	Left Cheek	26365	25	12	-5	0.195
1051	LTE 25	16QAM_10M	Left Tilted	26365	25	12	-5	0.234
1052	LTE 25	16QAM_10M	Right Cheek	26365	1	0	-5	0.183
1053	LTE 25	16QAM_10M	Right Tilted	26365	1	0	-5	0.24
1054	LTE 25	16QAM_10M	Left Cheek	26365	1	0	-5	0.196
1055	LTE 25	16QAM_10M	Left Tilted	26365	1	0	-5	0.223
1056	LTE 25	16QAM_10M	Right Cheek	26365	1	49	-5	0.2
1057	LTE 25	16QAM_10M	Right Tilted	26365	1	49	-5	0.256
1058	LTE 25	16QAM_10M	Left Cheek	26365	1	49	-5	0.209
1059	LTE 25	16QAM_10M	Left Tilted	26365	1	49	-5	0.245

FCC SAR Test Report

Plot No.	Band	Test Position	Channel	Cutback Power	SAR-1g (W/kg)
101	802.11b	Right Cheek	6	0	0.506
102	802.11b	Right Tilted	6	0	0.471
103	802.11b	Left Cheek	6	0	0.322
104	802.11b	Left Tilted	6	0	0.274
123	802.11b	Right Cheek	6	-5	0.109
119	802.11b	Right Tilted	6	-5	0.012
120	802.11b	Left Cheek	6	-5	0.102
121	802.11b	Left Tilted	6	-5	0.0000767

Note:

- SAR is performed on the highest power channel. When the SAR value of highest power channel for CDMA, LTE 50% RB and WLAN is less than 0.8 W/kg, SAR testing for optional channel is not required.
- According to KDB 941225, the LTE SAR testing for 100% RB is not required since the maximum SAR of 50% RB is less than 1.45 W/kg.
- According to KDB 941225, the LTE SAR testing was performed on largest channel bandwidth, and SAR for other channel bandwidths is not required since the maximum power of smaller channel bandwidth is within 1/2 dB higher or lower of measured for the largest channel bandwidth and maximum SAR of largest channel bandwidth is less than 1.45 W/kg.
- Since LTE and WLAN of this device supports VOIP capability through 3rd party apps software, we have evaluated data mode for head SAR.
- SAR testing for 802.11g/n is not required because its maximum power is less than 1/4 dB higher than 802.11b.

4.6.2 SAR Results for Body

<Body Worn Mode>

Plot No.	Band	Mode	Test Position	Separation Distance (cm)	Channel	Cutback Power	SAR-1g (W/kg)
1	CDMA BC0	RC3+SO32	Front Face	2.5	1013	0	0.395
2	CDMA BC0	RC3+SO32	Rear Face	2.5	1013	0	0.381
3	CDMA BC1	RC3+SO32	Front Face	2.5	25	0	0.065
4	CDMA BC1	RC3+SO32	Rear Face	2.5	25	0	0.064
5	CDMA BC15	RC3+SO32	Front Face	2.5	875	0	0.119
6	CDMA BC15	RC3+SO32	Rear Face	2.5	875	0	0.118



FCC SAR Test Report

Plot No.	Band	Mode	Test Position	Separation Distance (cm)	Channel	RB	RB Offset	Cutback Power	SAR-1g (W/kg)
328	LTE 2	QPSK_10M	Front Face	2.5	19150	25	12	0	0.032
329	LTE 2	QPSK_10M	Rear Face	2.5	19150	25	12	0	0.099
330	LTE 2	QPSK_10M	Front Face	2.5	19150	1	0	0	0.038
331	LTE 2	QPSK_10M	Rear Face	2.5	19150	1	0	0	0.133
332	LTE 2	QPSK_10M	Front Face	2.5	19150	1	49	0	0.032
333	LTE 2	QPSK_10M	Rear Face	2.5	19150	1	49	0	0.124
1123	LTE 2	16QAM_10M	Front Face	2.5	19150	25	12	0	0.014
334	LTE 2	16QAM_10M	Rear Face	2.5	19150	25	12	0	0.076
1124	LTE 2	16QAM_10M	Front Face	2.5	19150	1	0	0	0.016
335	LTE 2	16QAM_10M	Rear Face	2.5	19150	1	0	0	0.109
1125	LTE 2	16QAM_10M	Front Face	2.5	19150	1	49	0	0.014
336	LTE 2	16QAM_10M	Rear Face	2.5	19150	1	49	0	0.119
337	LTE 4	QPSK_10M	Front Face	2.5	20000	25	12	0	0.069
320	LTE 4	QPSK_10M	Rear Face	2.5	20000	25	12	0	0.15
321	LTE 4	QPSK_10M	Front Face	2.5	20000	1	0	0	0.095
322	LTE 4	QPSK_10M	Rear Face	2.5	20000	1	0	0	0.203
323	LTE 4	QPSK_10M	Front Face	2.5	20000	1	49	0	0.095
324	LTE 4	QPSK_10M	Rear Face	2.5	20000	1	49	0	0.209
1110	LTE 4	16QAM_10M	Front Face	2.5	20000	25	12	0	0.026
325	LTE 4	16QAM_10M	Rear Face	2.5	20000	25	12	0	0.126
1111	LTE 4	16QAM_10M	Front Face	2.5	20000	1	0	0	0.026
326	LTE 4	16QAM_10M	Rear Face	2.5	20000	1	0	0	0.167
1112	LTE 4	16QAM_10M	Front Face	2.5	20000	1	49	0	0.027
327	LTE 4	16QAM_10M	Rear Face	2.5	20000	1	49	0	0.162
310	LTE 5	QPSK_10M	Front Face	2.5	20450	25	12	0	0.098
311	LTE 5	QPSK_10M	Rear Face	2.5	20450	25	12	0	0.175
312	LTE 5	QPSK_10M	Front Face	2.5	20450	1	0	0	0.126
313	LTE 5	QPSK_10M	Rear Face	2.5	20450	1	0	0	0.229
314	LTE 5	QPSK_10M	Front Face	2.5	20450	1	49	0	0.136
315	LTE 5	QPSK_10M	Rear Face	2.5	20450	1	49	0	0.246
459	LTE 5	16QAM_10M	Front Face	2.5	20450	25	12	0	0.138
316	LTE 5	16QAM_10M	Rear Face	2.5	20450	25	12	0	0.141
460	LTE 5	16QAM_10M	Front Face	2.5	20450	1	0	0	0.184
317	LTE 5	16QAM_10M	Rear Face	2.5	20450	1	0	0	0.182
461	LTE 5	16QAM_10M	Front Face	2.5	20450	1	49	0	0.198
318	LTE 5	16QAM_10M	Rear Face	2.5	20450	1	49	0	0.198
301	LTE 12	QPSK_10M	Front Face	2.5	23130	25	12	0	0.079
302	LTE 12	QPSK_10M	Rear Face	2.5	23130	25	12	0	0.23
303	LTE 12	QPSK_10M	Front Face	2.5	23130	1	0	0	0.186
304	LTE 12	QPSK_10M	Rear Face	2.5	23130	1	0	0	0.423
305	LTE 12	QPSK_10M	Front Face	2.5	23130	1	49	0	0.091
306	LTE 12	QPSK_10M	Rear Face	2.5	23130	1	49	0	0.216
1150	LTE 12	16QAM_10M	Front Face	2.5	23130	25	12	0	0.107
307	LTE 12	16QAM_10M	Rear Face	2.5	23130	25	12	0	0.129
1151	LTE 12	16QAM_10M	Front Face	2.5	23130	1	0	0	0.21
308	LTE 12	16QAM_10M	Rear Face	2.5	23130	1	0	0	0.312
1152	LTE 12	16QAM_10M	Front Face	2.5	23130	1	49	0	0.099
309	LTE 12	16QAM_10M	Rear Face	2.5	23130	1	49	0	0.131



FCC SAR Test Report

Plot No.	Band	Mode	Test Position	Separation Distance (cm)	Channel	RB	RB Offset	Cutback Power	SAR-1g (W/kg)
338	LTE 25	QPSK_10M	Front Face	2.5	26365	25	12	0	0.047
339	LTE 25	QPSK_10M	Rear Face	2.5	26365	25	12	0	0.132
340	LTE 25	QPSK_10M	Front Face	2.5	26365	1	0	0	0.053
341	LTE 25	QPSK_10M	Rear Face	2.5	26365	1	0	0	0.168
342	LTE 25	QPSK_10M	Front Face	2.5	26365	1	49	0	0.045
343	LTE 25	QPSK_10M	Rear Face	2.5	26365	1	49	0	0.164
1135	LTE 25	16QAM_10M	Front Face	2.5	26365	25	12	0	0.018
344	LTE 25	16QAM_10M	Rear Face	2.5	26365	25	12	0	0.115
1136	LTE 25	16QAM_10M	Front Face	2.5	26365	1	0	0	0.019
345	LTE 25	16QAM_10M	Rear Face	2.5	26365	1	0	0	0.143
1137	LTE 25	16QAM_10M	Front Face	2.5	26365	1	49	0	0.018
346	LTE 25	16QAM_10M	Rear Face	2.5	26365	1	49	0	0.13

Plot No.	Band	Test Position	Separation Distance (cm)	Channel	Cutback Power	SAR-1g (W/kg)
108	802.11b	Front Face	2.5	6	0	0.032
109	802.11b	Rear Face	2.5	6	0	0.126

Note:

- SAR is performed on the highest power channel. When the SAR value of highest power channel for CDMA, LTE 50% RB and WLAN is less than 0.8 W/kg, SAR testing for optional channel is not required.
-
- According to KDB 941225, the SAR testing for 100% RB is not required since the maximum SAR of 50% RB is less than 1.45 W/kg.
- According to KDB 941225, the SAR testing was performed on largest channel bandwidth, and SAR for other channel bandwidths is not required since the maximum power of smaller channel bandwidth is within 1/2 dB higher or lower of measured for the largest channel bandwidth and maximum SAR of largest channel bandwidth is less than 1.45 W/kg.
- Since LTE and WLAN of this device supports VOIP capability through 3rd party apps software, we have evaluated data mode for body worn mode.
- SAR testing for 802.11g/n is not required because its maximum power is less than 1/4 dB higher than 802.11b.



FCC SAR Test Report

A D T

<Hotspot Mode>

Plot No.	Band	Mode	Test Position	Separation Distance (cm)	Channel	Cutback Power	SAR-1g (W/kg)
7	CDMA BC0	RC3+SO32	Front Face	1	1013	0	1.12
8	CDMA BC0	RC3+SO32	Rear Face	1	1013	0	1.06
9	CDMA BC0	RC3+SO32	Left Side	1	1013	0	0.779
10	CDMA BC0	RC3+SO32	Right Side	1	1013	0	0.892
11	CDMA BC0	RC3+SO32	Bottom Side	1	1013	0	0.07
12	CDMA BC0	RC3+SO32	Front Face	1	384	0	1.14
13	CDMA BC0	RC3+SO32	Front Face	1	777	0	1.08
14	CDMA BC0	RC3+SO32	Rear Face	1	384	0	0.999
15	CDMA BC0	RC3+SO32	Rear Face	1	777	0	0.919
16	CDMA BC0	RC3+SO32	Right Side	1	384	0	0.849
17	CDMA BC0	RC3+SO32	Right Side	1	777	0	0.793
34	CDMA BC1	RC3+SO32	Front Face	1	25	-7.5	0.428
35	CDMA BC1	RC3+SO32	Rear Face	1	25	-7.5	0.525
20	CDMA BC1	RC3+SO32	Left Side	1	25	-7.5	0.017
21	CDMA BC1	RC3+SO32	Right Side	1	25	-7.5	0.095
22	CDMA BC1	RC3+SO32	Bottom Side	1	25	-7.5	1.04
37	CDMA BC1	RC3+SO32	Bottom Side	1	600	-7.5	1.12
38	CDMA BC1	RC3+SO32	Bottom Side	1	1175	-7.5	1.1
23	CDMA BC15	RC3+SO32	Front Face	1	875	-7.5	0.581
36	CDMA BC15	RC3+SO32	Rear Face	1	875	-7.5	0.688
25	CDMA BC15	RC3+SO32	Left Side	1	875	-7.5	0.086
26	CDMA BC15	RC3+SO32	Right Side	1	875	-7.5	0.047
27	CDMA BC15	RC3+SO32	Bottom Side	1	875	-7.5	1.19
39	CDMA BC15	RC3+SO32	Bottom Side	1	25	-7.5	1.07
40	CDMA BC15	RC3+SO32	Bottom Side	1	425	-7.5	1.05



FCC SAR Test Report

Plot No.	Band	Mode	Test Position	Separation Distance (cm)	Channel	RB	RB Offset	Cutback Power	SAR-1g (W/kg)
391	LTE 2	QPSK_10M	Front Face	1	19150	25	12	-5	0.282
392	LTE 2	QPSK_10M	Rear Face	1	19150	25	12	-5	0.512
393	LTE 2	QPSK_10M	Right Side	1	19150	25	12	-5	0.114
394	LTE 2	QPSK_10M	Top Side	1	19150	25	12	-5	0.308
395	LTE 2	QPSK_10M	Front Face	1	19150	1	0	-5	0.457
396	LTE 2	QPSK_10M	Rear Face	1	19150	1	0	-5	0.672
397	LTE 2	QPSK_10M	Right Side	1	19150	1	0	-5	0.124
398	LTE 2	QPSK_10M	Top Side	1	19150	1	0	-5	0.405
399	LTE 2	QPSK_10M	Front Face	1	19150	1	49	-5	0.532
400	LTE 2	QPSK_10M	Rear Face	1	19150	1	49	-5	0.69
401	LTE 2	QPSK_10M	Right Side	1	19150	1	49	-5	0.142
402	LTE 2	QPSK_10M	Top Side	1	19150	1	49	-5	0.458
1114	LTE 2	16QAM_10M	Front Face	1	19150	25	12	-5	0.13
403	LTE 2	16QAM_10M	Rear Face	1	19150	25	12	-5	0.414
1115	LTE 2	16QAM_10M	Right Side	1	19150	25	12	-5	0.121
1116	LTE 2	16QAM_10M	Top Side	1	19150	25	12	-5	0.129
1117	LTE 2	16QAM_10M	Front Face	1	19150	1	0	-5	0.14
404	LTE 2	16QAM_10M	Rear Face	1	19150	1	0	-5	0.552
1118	LTE 2	16QAM_10M	Right Side	1	19150	1	0	-5	0.125
1119	LTE 2	16QAM_10M	Top Side	1	19150	1	0	-5	0.138
1120	LTE 2	16QAM_10M	Front Face	1	19150	1	49	-5	0.136
405	LTE 2	16QAM_10M	Rear Face	1	19150	1	49	-5	0.552
1121	LTE 2	16QAM_10M	Right Side	1	19150	1	49	-5	0.132
1122	LTE 2	16QAM_10M	Top Side	1	19150	1	49	-5	0.135
377	LTE 4	QPSK_10M	Front Face	1	20000	25	12	-5	0.151
378	LTE 4	QPSK_10M	Rear Face	1	20000	25	12	-5	0.562
379	LTE 4	QPSK_10M	Right Side	1	20000	25	12	-5	0.097
380	LTE 4	QPSK_10M	Top Side	1	20000	25	12	-5	0.232
381	LTE 4	QPSK_10M	Front Face	1	20000	1	0	-5	0.275
382	LTE 4	QPSK_10M	Rear Face	1	20000	1	0	-5	0.681
383	LTE 4	QPSK_10M	Right Side	1	20000	1	0	-5	0.096
427	LTE 4	QPSK_10M	Top Side	1	20000	1	0	-5	0.302
384	LTE 4	QPSK_10M	Front Face	1	20000	1	49	-5	0.321
386	LTE 4	QPSK_10M	Rear Face	1	20000	1	49	-5	0.752
385	LTE 4	QPSK_10M	Right Side	1	20000	1	49	-5	0.103
387	LTE 4	QPSK_10M	Top Side	1	20000	1	49	-5	0.314
1101	LTE 4	16QAM_10M	Front Face	1	20000	25	12	-5	0.184
388	LTE 4	16QAM_10M	Rear Face	1	20000	25	12	-5	0.433
1102	LTE 4	16QAM_10M	Right Side	1	20000	25	12	-5	0.126
1103	LTE 4	16QAM_10M	Top Side	1	20000	25	12	-5	0.226
1104	LTE 4	16QAM_10M	Front Face	1	20000	1	0	-5	0.198
389	LTE 4	16QAM_10M	Rear Face	1	20000	1	0	-5	0.56
1105	LTE 4	16QAM_10M	Right Side	1	20000	1	0	-5	0.128
1106	LTE 4	16QAM_10M	Top Side	1	20000	1	0	-5	0.222
1107	LTE 4	16QAM_10M	Front Face	1	20000	1	49	-5	0.202
390	LTE 4	16QAM_10M	Rear Face	1	20000	1	49	-5	0.58
1108	LTE 4	16QAM_10M	Right Side	1	20000	1	49	-5	0.132
1109	LTE 4	16QAM_10M	Top Side	1	20000	1	49	-5	0.231



FCC SAR Test Report

Plot No.	Band	Mode	Test Position	Separation Distance (cm)	Channel	RB	RB Offset	Cutback Power	SAR-1g (W/kg)
362	LTE 5	QPSK_10M	Front Face	1	20450	25	12	-5	0.313
363	LTE 5	QPSK_10M	Rear Face	1	20450	25	12	-5	0.612
364	LTE 5	QPSK_10M	Left Side	1	20450	25	12	-5	0.111
365	LTE 5	QPSK_10M	Top Side	1	20450	25	12	-5	0.147
366	LTE 5	QPSK_10M	Front Face	1	20450	1	0	-5	0.399
367	LTE 5	QPSK_10M	Rear Face	1	20450	1	0	-5	0.786
368	LTE 5	QPSK_10M	Left Side	1	20450	1	0	-5	0.114
369	LTE 5	QPSK_10M	Top Side	1	20450	1	0	-5	0.183
370	LTE 5	QPSK_10M	Front Face	1	20450	1	49	-5	0.436
371	LTE 5	QPSK_10M	Rear Face	1	20450	1	49	-5	0.833
372	LTE 5	QPSK_10M	Left Side	1	20450	1	49	-5	0.123
373	LTE 5	QPSK_10M	Top Side	1	20450	1	49	-5	0.208
462	LTE 5	16QAM_10M	Front Face	1	20450	25	12	-5	0.267
374	LTE 5	16QAM_10M	Rear Face	1	20450	25	12	-5	0.498
451	LTE 5	16QAM_10M	Left Side	1	20450	25	12	-5	0.248
452	LTE 5	16QAM_10M	Top Side	1	20450	25	12	-5	0.139
453	LTE 5	16QAM_10M	Front Face	1	20450	1	0	-5	0.35
375	LTE 5	16QAM_10M	Rear Face	1	20450	1	0	-5	0.628
454	LTE 5	16QAM_10M	Left Side	1	20450	1	0	-5	0.302
455	LTE 5	16QAM_10M	Top Side	1	20450	1	0	-5	0.179
456	LTE 5	16QAM_10M	Front Face	1	20450	1	49	-5	0.376
376	LTE 5	16QAM_10M	Rear Face	1	20450	1	49	-5	0.674
457	LTE 5	16QAM_10M	Left Side	1	20450	1	49	-5	0.33
458	LTE 5	16QAM_10M	Top Side	1	20450	1	49	-5	0.199
347	LTE 12	QPSK_10M	Front Face	1	23130	25	12	-5	0.194
348	LTE 12	QPSK_10M	Rear Face	1	23130	25	12	-5	0.536
349	LTE 12	QPSK_10M	Left Side	1	23130	25	12	-5	0.2
350	LTE 12	QPSK_10M	Bottom Side	1	23130	25	12	-5	0.224
351	LTE 12	QPSK_10M	Front Face	1	23130	1	0	-5	0.269
352	LTE 12	QPSK_10M	Rear Face	1	23130	1	0	-5	0.78
353	LTE 12	QPSK_10M	Left Side	1	23130	1	0	-5	0.265
354	LTE 12	QPSK_10M	Bottom Side	1	23130	1	0	-5	0.292
355	LTE 12	QPSK_10M	Front Face	1	23130	1	49	-5	0.131
356	LTE 12	QPSK_10M	Rear Face	1	23130	1	49	-5	0.376
357	LTE 12	QPSK_10M	Left Side	1	23130	1	49	-5	0.152
358	LTE 12	QPSK_10M	Bottom Side	1	23130	1	49	-5	0.166
1139	LTE 12	16QAM_10M	Front Face	1	23130	25	12	-5	0.202
359	LTE 12	16QAM_10M	Rear Face	1	23130	25	12	-5	0.539
1153	LTE 12	16QAM_10M	Left Side	1	23130	25	12	-5	0.217
1141	LTE 12	16QAM_10M	Bottom Side	1	23130	25	12	-5	0.244
1142	LTE 12	16QAM_10M	Front Face	1	23130	1	0	-5	0.191
360	LTE 12	16QAM_10M	Rear Face	1	23130	1	0	-5	0.72
1143	LTE 12	16QAM_10M	Left Side	1	23130	1	0	-5	0.289
1145	LTE 12	16QAM_10M	Bottom Side	1	23130	1	0	-5	0.309
1146	LTE 12	16QAM_10M	Front Face	1	23130	1	49	-5	0.193
361	LTE 12	16QAM_10M	Rear Face	1	23130	1	49	-5	0.346
1147	LTE 12	16QAM_10M	Left Side	1	23130	1	49	-5	0.154
1149	LTE 12	16QAM_10M	Bottom Side	1	23130	1	49	-5	0.195



FCC SAR Test Report

Plot No.	Band	Mode	Test Position	Separation Distance (cm)	Channel	RB	RB Offset	Cutback Power	SAR-1g (W/kg)
406	LTE 25	QPSK_10M	Front Face	1	26365	25	12	-5	0.367
407	LTE 25	QPSK_10M	Rear Face	1	26365	25	12	-5	0.609
408	LTE 25	QPSK_10M	Right Side	1	26365	25	12	-5	0.096
409	LTE 25	QPSK_10M	Top Side	1	26365	25	12	-5	0.316
410	LTE 25	QPSK_10M	Front Face	1	26365	1	0	-5	0.407
411	LTE 25	QPSK_10M	Rear Face	1	26365	1	0	-5	0.787
412	LTE 25	QPSK_10M	Right Side	1	26365	1	0	-5	0.090
413	LTE 25	QPSK_10M	Top Side	1	26365	1	0	-5	0.319
414	LTE 25	QPSK_10M	Front Face	1	26365	1	49	-5	0.577
415	LTE 25	QPSK_10M	Rear Face	1	26365	1	49	-5	0.800
416	LTE 25	QPSK_10M	Right Side	1	26365	1	49	-5	0.127
417	LTE 25	QPSK_10M	Top Side	1	26365	1	49	-5	0.499
1126	LTE 25	16QAM_10M	Front Face	1	26365	25	12	-5	0.141
418	LTE 25	16QAM_10M	Rear Face	1	26365	25	12	-5	0.577
1127	LTE 25	16QAM_10M	Right Side	1	26365	25	12	-5	0.1
1128	LTE 25	16QAM_10M	Top Side	1	26365	25	12	-5	0.139
1129	LTE 25	16QAM_10M	Front Face	1	26365	1	0	-5	0.138
419	LTE 25	16QAM_10M	Rear Face	1	26365	1	0	-5	0.745
1130	LTE 25	16QAM_10M	Right Side	1	26365	1	0	-5	0.097
1131	LTE 25	16QAM_10M	Top Side	1	26365	1	0	-5	0.138
1132	LTE 25	16QAM_10M	Front Face	1	26365	1	49	-5	0.150
420	LTE 25	16QAM_10M	Rear Face	1	26365	1	49	-5	0.718
1133	LTE 25	16QAM_10M	Right Side	1	26365	1	49	-5	0.111
1134	LTE 25	16QAM_10M	Top Side	1	26365	1	49	-5	0.151

Plot No.	Band	Test Position	Separation Distance (cm)	Channel	Cutback Power	SAR-1g (W/kg)
116	802.11b	Front Face	1	6	-5	0.039
117	802.11b	Rear Face	1	6	-5	0.352
115	802.11b	Right Side	1	6	-5	0.419

Note:

- SAR is performed on the highest power channel. When the SAR value of highest power channel for CDMA, LTE 50% RB and WLAN is less than 0.8 W/kg, SAR testing for optional channel is not required.
- According to KDB 941225, the SAR testing for EVDO Rev.0 and Rev.A is not required because their maximum power is less than 1xRTT.
- According to KDB 941225, the LTE SAR testing for 100% RB is not required since the maximum SAR of 50% RB is less than 1.45 W/kg.
- According to KDB 941225, the LTE SAR testing was performed on largest channel bandwidth, and SAR for other channel bandwidths is not required since the maximum power of smaller channel bandwidth is within 1/2 dB higher or lower of measured for the largest channel bandwidth and maximum SAR of largest channel bandwidth is less than 1.45 W/kg.
- SAR testing for 802.11g/n is not required because its maximum power is less than 1/4 dB higher than 802.11b.

Test Engineer : Eli Hsu, Morrison Huang and Mars Chang



FCC SAR Test Report

4.6.3 Simultaneous Multi-band Transmission Evaluation

No.	Conditions (SAR1 + SAR2)	Mode	Position	Max. SAR1	Max. SAR2	SAR Summation	SPLSR
1	CDMA BC0 + WLAN	Head	Right Cheek	1.02	0.109	1.129	-
			Right Tilted	0.418	0.012	0.43	-
			Left Cheek	1.08	0.102	1.182	-
			Left Tilted	0.494	0.0000767	0.4940767	-
		Body-Worn	Front Face	0.395	0.032	0.427	-
			Rear Face	0.381	0.126	0.507	-
		Hotspot	Front Face	1.14	0.039	1.179	-
			Rear Face	1.06	0.352	1.412	-
			Left Side	0.779	0	0.779	-
			Right Side	0.892	0.419	1.311	-
			Top Side	0	0	0	-
			Bottom Side	0.07	0	0.07	-
		2	CDMA BC1 + WLAN	Head	Right Cheek	0.621	0.109
Right Tilted	0.162				0.012	0.174	-
Left Cheek	0.33				0.102	0.432	-
Left Tilted	0.191				0.0000767	0.1910767	-
Body-Worn	Front Face			0.065	0.032	0.097	-
	Rear Face			0.064	0.126	0.19	-
Hotspot	Front Face			0.428	0.039	0.467	-
	Rear Face			0.525	0.352	0.877	-
	Left Side			0.017	0	0.017	-
	Right Side			0.095	0.419	0.514	-
	Top Side			0	0	0	-
	Bottom Side			1.12	0	1.12	-
3	CDMA BC15 + WLAN			Head	Right Cheek	0.577	0.109
		Right Tilted	0.285		0.012	0.297	-
		Left Cheek	0.66		0.102	0.762	-
		Left Tilted	0.327		0.0000767	0.3270767	-
		Body-Worn	Front Face	0.119	0.032	0.151	-
			Rear Face	0.118	0.126	0.244	-
		Hotspot	Front Face	0.581	0.039	0.62	-
			Rear Face	0.688	0.352	1.04	-
			Left Side	0.086	0	0.086	-
			Right Side	0.047	0.419	0.466	-
			Top Side	0	0	0	-
			Bottom Side	1.19	0	1.19	-
		4	LTE 2 + WLAN	Head	Right Cheek	0.387	0.109
Right Tilted	0.514				0.012	0.526	-
Left Cheek	0.417				0.102	0.519	-
Left Tilted	0.294				0.0000767	0.2940767	-
Body-Worn	Front Face			0.038	0.032	0.07	-
	Rear Face			0.133	0.126	0.259	-
Hotspot	Front Face			0.532	0.039	0.571	-
	Rear Face			0.69	0.352	1.042	-
	Left Side			0	0	0	-
	Right Side			0.142	0.419	0.561	-
	Top Side			0.458	0	0.458	-
	Bottom Side			0	0	0	-



FCC SAR Test Report

No.	Conditions (SAR1 + SAR2)	Mode	Position	Max. SAR1	Max. SAR2	SAR Summation	SPLSR
5	LTE 4 + WLAN	Head	Right Cheek	0.69	0.109	0.799	-
			Right Tilted	0.532	0.012	0.544	-
			Left Cheek	0.365	0.102	0.467	-
			Left Tilted	0.428	0.0000767	0.4280767	-
		Body-Worn	Front Face	0.095	0.032	0.127	-
			Rear Face	0.209	0.126	0.335	-
		Hotspot	Front Face	0.321	0.039	0.36	-
			Rear Face	0.752	0.352	1.104	-
			Left Side	0	0	0	-
			Right Side	0.103	0.419	0.522	-
			Top Side	0.314	0	0.314	-
			Bottom Side	0	0	0	-
		6	LTE 5 + WLAN	Head	Right Cheek	1.05	0.109
Right Tilted	0.767				0.012	0.779	-
Left Cheek	0.776				0.102	0.878	-
Left Tilted	0.583				0.0000767	0.5830767	-
Body-Worn	Front Face			0.136	0.032	0.168	-
	Rear Face			0.246	0.126	0.372	-
Hotspot	Front Face			0.436	0.039	0.475	-
	Rear Face			0.833	0.352	1.185	-
	Left Side			0.123	0	0.123	-
	Right Side			0	0.419	0.419	-
	Top Side			0.208	0	0.208	-
	Bottom Side			0	0	0	-
7	LTE 12 + WLAN			Head	Right Cheek	0.548	0.109
		Right Tilted	0.205		0.012	0.217	-
		Left Cheek	0.582		0.102	0.684	-
		Left Tilted	0.352		0.0000767	0.3520767	-
		Body-Worn	Front Face	0.186	0.032	0.218	-
			Rear Face	0.423	0.126	0.549	-
		Hotspot	Front Face	0.269	0.039	0.308	-
			Rear Face	0.78	0.352	1.132	-
			Left Side	0.265	0	0.265	-
			Right Side	0	0.419	0.419	-
			Top Side	0	0	0	-
			Bottom Side	0.292	0	0.292	-
		8	LTE 25 + WLAN	Head	Right Cheek	0.415	0.109
Right Tilted	0.624				0.012	0.636	-
Left Cheek	0.465				0.102	0.567	-
Left Tilted	0.486				0.0000767	0.4860767	-
Body-Worn	Front Face			0.053	0.032	0.085	-
	Rear Face			0.168	0.126	0.294	-
Hotspot	Front Face			0.577	0.039	0.616	-
	Rear Face			0.8	0.352	1.152	-
	Left Side			0	0	0	-
	Right Side			0.127	0.419	0.546	-
	Top Side			0.499	0	0.499	-
	Bottom Side			0	0	0	-



FCC SAR Test Report

A D T

No.	Conditions (SAR1 + SAR2 + SAR3)	Mode	Position	Max. SAR1	Max. SAR2	Max. SAR3	SAR Summation	SPLSR
9	CDMA BC0 + LTE 2 + WLAN	Head	Right Cheek	1.02	0.197	0.109	1.326	-
			Right Tilted	0.418	0.232	0.012	0.662	-
			Left Cheek	1.08	0.209	0.102	1.391	-
			Left Tilted	0.494	0.18	0.0000767	0.6740767	-
		Body-Worn	Front Face	0.395	0.038	0.032	0.465	-
			Rear Face	0.381	0.133	0.126	0.64	-
		Hotspot	Front Face	1.14	0.532	0.039	1.711	Analyzed as below
			Rear Face	1.06	0.69	0.352	2.102	Analyzed as below
			Left Side	0.779	0	0	0.779	-
			Right Side	0.892	0.142	0.419	1.453	-
			Top Side	0	0.458	0	0.458	-
			Bottom Side	0.07	0	0	0.07	-
10	CDMA BC0 + LTE 4 + WLAN	Head	Right Cheek	1.02	0.294	0.109	1.423	-
			Right Tilted	0.418	0.427	0.012	0.857	-
			Left Cheek	1.08	0.34	0.102	1.522	-
			Left Tilted	0.494	0.413	0.0000767	0.9070767	-
		Body-Worn	Front Face	0.395	0.095	0.032	0.522	-
			Rear Face	0.381	0.209	0.126	0.716	-
		Hotspot	Front Face	1.14	0.321	0.039	1.5	-
			Rear Face	1.06	0.752	0.352	2.164	Analyzed as below
			Left Side	0.779	0	0	0.779	-
			Right Side	0.892	0.103	0.419	1.414	-
			Top Side	0	0.314	0	0.314	-
			Bottom Side	0.07	0	0	0.07	-
11	CDMA BC0 + LTE 5 + WLAN	Head	Right Cheek	1.02	0.409	0.109	1.538	-
			Right Tilted	0.418	0.303	0.012	0.733	-
			Left Cheek	1.08	0.282	0.102	1.464	-
			Left Tilted	0.494	0.206	0.0000767	0.7000767	-
		Body-Worn	Front Face	0.395	0.136	0.032	0.563	-
			Rear Face	0.381	0.246	0.126	0.753	-
		Hotspot	Front Face	1.14	0.436	0.039	1.615	Analyzed as below
			Rear Face	1.06	0.833	0.352	2.245	Analyzed as below
			Left Side	0.779	0.123	0	0.902	-
			Right Side	0.892	0	0.419	1.311	-
			Top Side	0	0.208	0	0.208	-
			Bottom Side	0.07	0	0	0.07	-
12	CDMA BC0 + LTE 12 + WLAN	Head	Right Cheek	1.02	0.208	0.109	1.337	-
			Right Tilted	0.418	0.146	0.012	0.576	-
			Left Cheek	1.08	0.312	0.102	1.494	-
			Left Tilted	0.494	0.158	0.0000767	0.6520767	-
		Body-Worn	Front Face	0.395	0.186	0.032	0.613	-
			Rear Face	0.381	0.423	0.126	0.93	-
		Hotspot	Front Face	1.14	0.269	0.039	1.448	-
			Rear Face	1.06	0.78	0.352	2.192	Analyzed as below
			Left Side	0.779	0.265	0	1.044	-
			Right Side	0.892	0	0.419	1.311	-
			Top Side	0	0	0	0	-
			Bottom Side	0.07	0.292	0	0.362	-



FCC SAR Test Report

No.	Conditions (SAR1 + SAR2 + SAR3)	Mode	Position	Max. SAR1	Max. SAR2	Max. SAR3	SAR Summation	SPLSR
13	CDMA BC0 + LTE 25 + WLAN	Head	Right Cheek	1.02	0.204	0.109	1.333	-
			Right Tilted	0.418	0.322	0.012	0.752	-
			Left Cheek	1.08	0.315	0.102	1.497	-
			Left Tilted	0.494	0.293	0.0000767	0.7870767	-
		Body-Worn	Front Face	0.395	0.053	0.032	0.48	-
			Rear Face	0.381	0.168	0.126	0.675	-
		Hotspot	Front Face	1.14	0.577	0.039	1.756	Analyzed as below
			Rear Face	1.06	0.8	0.352	2.212	Analyzed as below
			Left Side	0.779	0	0	0.779	-
			Right Side	0.892	0.127	0.419	1.438	-
			Top Side	0	0.499	0	0.499	-
			Bottom Side	0.07	0	0	0.07	-
14	CDMA BC1 + LTE 2 + WLAN	Head	Right Cheek	0.621	0.197	0.109	0.927	-
			Right Tilted	0.162	0.232	0.012	0.406	-
			Left Cheek	0.33	0.209	0.102	0.641	-
			Left Tilted	0.191	0.18	0.0000767	0.3710767	-
		Body-Worn	Front Face	0.065	0.038	0.032	0.135	-
			Rear Face	0.064	0.133	0.126	0.323	-
		Hotspot	Front Face	0.428	0.532	0.039	0.999	-
			Rear Face	0.525	0.69	0.352	1.567	-
			Left Side	0.017	0	0	0.017	-
			Right Side	0.095	0.142	0.419	0.656	-
			Top Side	0	0.458	0	0.458	-
			Bottom Side	1.12	0	0	1.12	-
15	CDMA BC1 + LTE 4 + WLAN	Head	Right Cheek	0.621	0.294	0.109	1.024	-
			Right Tilted	0.162	0.427	0.012	0.601	-
			Left Cheek	0.33	0.34	0.102	0.772	-
			Left Tilted	0.191	0.413	0.0000767	0.6040767	-
		Body-Worn	Front Face	0.065	0.095	0.032	0.192	-
			Rear Face	0.064	0.209	0.126	0.399	-
		Hotspot	Front Face	0.428	0.321	0.039	0.788	-
			Rear Face	0.525	0.752	0.352	1.629	Analyzed as below
			Left Side	0.017	0	0	0.017	-
			Right Side	0.095	0.103	0.419	0.617	-
			Top Side	0	0.314	0	0.314	-
			Bottom Side	1.12	0	0	1.12	-
16	CDMA BC1 + LTE 5 + WLAN	Head	Right Cheek	0.621	0.409	0.109	1.139	-
			Right Tilted	0.162	0.303	0.012	0.477	-
			Left Cheek	0.33	0.282	0.102	0.714	-
			Left Tilted	0.191	0.206	0.0000767	0.3970767	-
		Body-Worn	Front Face	0.065	0.136	0.032	0.233	-
			Rear Face	0.064	0.246	0.126	0.436	-
		Hotspot	Front Face	0.428	0.436	0.039	0.903	-
			Rear Face	0.525	0.833	0.352	1.71	Analyzed as below
			Left Side	0.017	0.123	0	0.14	-
			Right Side	0.095	0	0.419	0.514	-
			Top Side	0	0.208	0	0.208	-
			Bottom Side	1.12	0	0	1.12	-



FCC SAR Test Report

A D T

No.	Conditions (SAR1 + SAR2 + SAR3)	Mode	Position	Max. SAR1	Max. SAR2	Max. SAR3	SAR Summation	SPLSR
17	CDMA BC1 + LTE 12 + WLAN	Head	Right Cheek	0.621	0.208	0.109	0.938	-
			Right Tilted	0.162	0.146	0.012	0.32	-
			Left Cheek	0.33	0.312	0.102	0.744	-
			Left Tilted	0.191	0.158	0.0000767	0.3490767	-
		Body-Worn	Front Face	0.065	0.186	0.032	0.283	-
			Rear Face	0.064	0.423	0.126	0.613	-
		Hotspot	Front Face	0.428	0.269	0.039	0.736	-
			Rear Face	0.525	0.78	0.352	1.657	Analyzed as below
			Left Side	0.017	0.265	0	0.282	-
			Right Side	0.095	0	0.419	0.514	-
			Top Side	0	0	0	0	-
			Bottom Side	1.12	0.292	0	1.412	-
18	CDMA BC1 + LTE 25 + WLAN	Head	Right Cheek	0.621	0.204	0.109	0.934	-
			Right Tilted	0.162	0.322	0.012	0.496	-
			Left Cheek	0.33	0.315	0.102	0.747	-
			Left Tilted	0.191	0.293	0.0000767	0.4840767	-
		Body-Worn	Front Face	0.065	0.053	0.032	0.15	-
			Rear Face	0.064	0.168	0.126	0.358	-
		Hotspot	Front Face	0.428	0.577	0.039	1.044	-
			Rear Face	0.525	0.8	0.352	1.677	Analyzed as below
			Left Side	0.017	0	0	0.017	-
			Right Side	0.095	0.127	0.419	0.641	-
			Top Side	0	0.499	0	0.499	-
			Bottom Side	1.12	0	0	1.12	-
19	CDMA BC15 + LTE 2 + WLAN	Head	Right Cheek	0.577	0.197	0.109	0.883	-
			Right Tilted	0.285	0.232	0.012	0.529	-
			Left Cheek	0.66	0.209	0.102	0.971	-
			Left Tilted	0.327	0.18	0.0000767	0.5070767	-
		Body-Worn	Front Face	0.119	0.038	0.032	0.189	-
			Rear Face	0.118	0.133	0.126	0.377	-
		Hotspot	Front Face	0.581	0.532	0.039	1.152	-
			Rear Face	0.688	0.69	0.352	1.73	Analyzed as below
			Left Side	0.086	0	0	0.086	-
			Right Side	0.047	0.142	0.419	0.608	-
			Top Side	0	0.458	0	0.458	-
			Bottom Side	1.19	0	0	1.19	-
20	CDMA BC15 + LTE 4 + WLAN	Head	Right Cheek	0.577	0.294	0.109	0.98	-
			Right Tilted	0.285	0.427	0.012	0.724	-
			Left Cheek	0.66	0.34	0.102	1.102	-
			Left Tilted	0.327	0.413	0.0000767	0.7400767	-
		Body-Worn	Front Face	0.119	0.095	0.032	0.246	-
			Rear Face	0.118	0.209	0.126	0.453	-
		Hotspot	Front Face	0.581	0.321	0.039	0.941	-
			Rear Face	0.688	0.752	0.352	1.792	Analyzed as below
			Left Side	0.086	0	0	0.086	-
			Right Side	0.047	0.103	0.419	0.569	-
			Top Side	0	0.314	0	0.314	-
			Bottom Side	1.19	0	0	1.19	-



FCC SAR Test Report

A D T

No.	Conditions (SAR1 + SAR2 + SAR3)	Mode	Position	Max. SAR1	Max. SAR2	Max. SAR3	SAR Summation	SPLSR
21	CDMA BC15 + LTE 5 + WLAN	Head	Right Cheek	0.577	0.409	0.109	1.095	-
			Right Tilted	0.285	0.303	0.012	0.6	-
			Left Cheek	0.66	0.282	0.102	1.044	-
			Left Tilted	0.327	0.206	0.0000767	0.5330767	-
		Body-Worn	Front Face	0.119	0.136	0.032	0.287	-
			Rear Face	0.118	0.246	0.126	0.49	-
		Hotspot	Front Face	0.581	0.436	0.039	1.056	-
			Rear Face	0.688	0.833	0.352	1.873	Analyzed as below
			Left Side	0.086	0.123	0	0.209	-
			Right Side	0.047	0	0.419	0.466	-
			Top Side	0	0.208	0	0.208	-
			Bottom Side	1.19	0	0	1.19	-
22	CDMA BC15 + LTE 12 + WLAN	Head	Right Cheek	0.577	0.208	0.109	0.894	-
			Right Tilted	0.285	0.146	0.012	0.443	-
			Left Cheek	0.66	0.312	0.102	1.074	-
			Left Tilted	0.327	0.158	0.0000767	0.4850767	-
		Body-Worn	Front Face	0.119	0.186	0.032	0.337	-
			Rear Face	0.118	0.423	0.126	0.667	-
		Hotspot	Front Face	0.581	0.269	0.039	0.889	-
			Rear Face	0.688	0.78	0.352	1.82	Analyzed as below
			Left Side	0.086	0.265	0	0.351	-
			Right Side	0.047	0	0.419	0.466	-
			Top Side	0	0	0	0	-
			Bottom Side	1.19	0.292	0	1.482	-
23	CDMA BC15 + LTE 25 + WLAN	Head	Right Cheek	0.577	0.204	0.109	0.89	-
			Right Tilted	0.285	0.322	0.012	0.619	-
			Left Cheek	0.66	0.315	0.102	1.077	-
			Left Tilted	0.327	0.293	0.0000767	0.6200767	-
		Body-Worn	Front Face	0.119	0.053	0.032	0.204	-
			Rear Face	0.118	0.168	0.126	0.412	-
		Hotspot	Front Face	0.581	0.577	0.039	1.197	-
			Rear Face	0.688	0.8	0.352	1.84	Analyzed as below
			Left Side	0.086	0	0	0.086	-
			Right Side	0.047	0.127	0.419	0.593	-
			Top Side	0	0.499	0	0.499	-
			Bottom Side	1.19	0	0	1.19	-

Note:

1. The maximum SAR summation is calculated based on the same configuration and test position.
2. The calculation of SPLSR (SAR to Peak Location Spacing Ratio) is as follows.

FCC SAR Test Report

<SPLSR calculation procedure>

- 1) Use DASY software to open SAR data file with zoom scan results.
- 2) Export data file to SEMCAD using 'Field Data Export' function.
- 3) Search for highest SAR based on the imported measured/interpolated data and identify the X, Y, and Z coordinates. Per the SAR system manufacture, DASY stores the individual coordinates of each measurement point in the measurement file where the, center coordinate (x=0, y=0) is always the Grid Reference Point as set in DASY for a phantom section.
- 4) Calculate the peak SAR separation distances using the Pythagoras' theorem where

$$\text{Peak Location Separation} = \text{Sqrt}[(X_1 - X_2)^2 + (Y_1 - Y_2)^2 + (Z_1 - Z_2)^2]$$
- 5) Calculate SPLSR = (SAR1 + SAR2) / Peak SAR separation distance.
- 6) The SPLSR calculation plots shown in test report are for reference only as the images were generated in a separate software program to add the antenna and arrow references. The distance information in the calculations below each plot is derived from the DASY SAR zoom scan data as specified in this procedure.

1. The calculation of SPLSR for (CDMA BC0 + LTE 2 + WLAN, Hotspot-Front Face) is as below:

Coordinate of Peak SAR Location (X, Y, Z) & SAR Value:

SAR 1 : CDMA BC0 (-2.93, -1, -20.72), 1.14

SAR 2 : LTE 2 (-1.7, 4.96, -20.7), 0.532

SAR 3 : WLAN (3.84, 0.56, -18), 0.039

Peak Location Spacing for SAR1-SAR2 = 6.1 cm

Peak Location Spacing for SAR1-SAR3 = 7.5 cm

Peak Location Spacing for SAR2-SAR3 = 7.6 cm

SPLSR for SAR1-SAR2 = (1.14 + 0.532) / 6.1 = **0.274**

SPLSR for SAR1-SAR3 = (1.14 + 0.039) / 7.5 = **0.157**

SPLSR for SAR2-SAR3 = (0.532 + 0.039) / 7.6 = **0.075**

The volume scan for this condition is not required because all calculated SPLSR are less than 0.3.

2. The calculation of SPLSR for (CDMA BC0 + LTE 2 + WLAN, Hotspot-Rear Face) is as below:

Coordinate of Peak SAR Location (X, Y, Z) & SAR Value:

SAR 1 : CDMA BC0 (-1.49, -0.64, -20.71), 1.06

SAR 2 : LTE 2 (-4.1, 4.6, -20.5), 0.69

SAR 3 : WLAN (-3.16, 0.16, -18), 0.352

Peak Location Spacing for SAR1-SAR2 = 5.9 cm

Peak Location Spacing for SAR1-SAR3 = 3.3 cm

Peak Location Spacing for SAR2-SAR3 = 5.2 cm

SPLSR for SAR1-SAR2 = (1.06 + 0.69) / 5.9 = **0.297**

SPLSR for SAR1-SAR3 = (1.06 + 0.352) / 3.3 = **0.428**

SPLSR for SAR2-SAR3 = (0.69 + 0.352) / 5.2 = **0.200**

Since the SPLSR is larger than 0.3, volume scan is required and the testing result is as below.

Plot No.	Band	Mode	Test Position	Separation Distance (cm)	Channel	RB	RB Offset	Cutback Power	SAR-1g (W/kg)	Multi-Band SAR-1g (W/kg)
702	CDMA BC0	RC3+SO32	Rear Face	1	1013	-	-	0	0.947	1.17
714	LTE 2	QPSK_10M			19150	1	49	-5	0.719	
723	802.11b	-			6	-	-	-5	0.397	

FCC SAR Test Report

3. The calculation of SPLSR for (CDMA BC0 + LTE 4 + WLAN, Hotspot-Rear Face) is as below:

Coordinate of Peak SAR Location (X, Y, Z) & SAR Value:

SAR 1 : CDMA BC0 (-1.49, -0.64, -20.71), 1.06

SAR 2 : LTE 4 (-4.38, 4.68, -20.7), 0.752

SAR 3 : WLAN (-3.16, 0.16, -18), 0.352

Peak Location Spacing for SAR1-SAR2 = 6.1 cm

Peak Location Spacing for SAR1-SAR3 = 3.3 cm

Peak Location Spacing for SAR2-SAR3 = 5.4 cm

SPLSR for SAR1-SAR2 = $(1.06 + 0.752) / 6.1 = 0.297$

SPLSR for SAR1-SAR3 = $(1.06 + 0.352) / 3.3 = 0.428$

SPLSR for SAR2-SAR3 = $(0.752 + 0.352) / 5.4 = 0.204$

Since the SPLSR is larger than 0.3, volume scan is required and the testing result is as below.

Plot No.	Band	Mode	Test Position	Separation Distance (cm)	Channel	RB	RB Offset	Cutback Power	SAR-1g (W/kg)	Multi-Band SAR-1g (W/kg)
702	CDMA BC0	RC3+SO32	Rear Face	1	1013	-	-	0	0.947	1.02
712	LTE 4	QPSK_10M			20000	1	49	-5	0.687	
723	802.11b	-			6	-	-	-5	0.397	

4. The calculation of SPLSR for (CDMA BC0 + LTE 5 + WLAN, Hotspot-Front Face) is as below:

Coordinate of Peak SAR Location (X, Y, Z) & SAR Value:

SAR 1 : CDMA BC0 (-2.93, -1, -20.72), 1.14

SAR 2 : LTE 5 (-3.58, 3.4, -20.57), 0.436

SAR 3 : WLAN (3.84, 0.56, -18), 0.039

Peak Location Spacing for SAR1-SAR2 = 4.5 cm

Peak Location Spacing for SAR1-SAR3 = 7.5 cm

Peak Location Spacing for SAR2-SAR3 = 8.4 cm

SPLSR for SAR1-SAR2 = $(1.14 + 0.436) / 4.5 = 0.350$

SPLSR for SAR1-SAR3 = $(1.14 + 0.039) / 7.5 = 0.157$

SPLSR for SAR2-SAR3 = $(0.436 + 0.039) / 8.4 = 0.057$

Since the SPLSR is larger than 0.3, volume scan is required and the testing result is as below.

Plot No.	Band	Mode	Test Position	Separation Distance (cm)	Channel	RB	RB Offset	Cutback Power	SAR-1g (W/kg)	Multi-Band SAR-1g (W/kg)
701	CDMA BC0	RC3+SO32	Front Face	1	384	-	-	0	1	1.29
710	LTE 5	QPSK_10M			20450	1	49	-5	0.458	
722	802.11b	-			6	-	-	-5	0.04	

FCC SAR Test Report

5. The calculation of SPLSR for (CDMA BC0 + LTE 5 + WLAN, Hotspot-Rear Face) is as below:

Coordinate of Peak SAR Location (X, Y, Z) & SAR Value:

SAR 1 : CDMA BC0 (-1.49, -0.64, -20.71), 1.06

SAR 2 : LTE 5 (1.02, 3.96, -20.58), 0.833

SAR 3 : WLAN (-3.16, 0.16, -18), 0.352

Peak Location Spacing for SAR1-SAR2 = 5.2 cm

Peak Location Spacing for SAR1-SAR3 = 3.3 cm

Peak Location Spacing for SAR2-SAR3 = 6.2 cm

SPLSR for SAR1-SAR2 = $(1.06 + 0.833) / 5.2 = 0.364$

SPLSR for SAR1-SAR3 = $(1.06 + 0.352) / 3.3 = 0.428$

SPLSR for SAR2-SAR3 = $(0.833 + 0.352) / 6.2 = 0.191$

Since the SPLSR is larger than 0.3, volume scan is required and the testing result is as below.

Plot No.	Band	Mode	Test Position	Separation Distance (cm)	Channel	RB	RB Offset	Cutback Power	SAR-1g (W/kg)	Multi-Band SAR-1g (W/kg)
702	CDMA BC0	RC3+SO32	Rear Face	1	1013	-	-	0	0.947	1.51
711	LTE 5	QPSK_10M			20450	1	49	-5	0.839	
723	802.11b	-			6	-	-	-5	0.397	

6. The calculation of SPLSR for (CDMA BC0 + LTE 12 + WLAN, Hotspot-Rear Face) is as below:

Coordinate of Peak SAR Location (X, Y, Z) & SAR Value:

SAR 1 : CDMA BC0 (-1.49, -0.64, -20.71), 1.06

SAR 2 : LTE 12 (-0.896, -5.8, -20.5), 0.78

SAR 3 : WLAN (-3.16, 0.16, -18), 0.352

Peak Location Spacing for SAR1-SAR2 = 5.2 cm

Peak Location Spacing for SAR1-SAR3 = 3.3 cm

Peak Location Spacing for SAR2-SAR3 = 6.8 cm

SPLSR for SAR1-SAR2 = $(1.06 + 0.78) / 5.2 = 0.354$

SPLSR for SAR1-SAR3 = $(1.06 + 0.352) / 3.3 = 0.428$

SPLSR for SAR2-SAR3 = $(0.78 + 0.352) / 6.8 = 0.166$

Since the SPLSR is larger than 0.3, volume scan is required and the testing result is as below.

Plot No.	Band	Mode	Test Position	Separation Distance (cm)	Channel	RB	RB Offset	Cutback Power	SAR-1g (W/kg)	Multi-Band SAR-1g (W/kg)
702	CDMA BC0	RC3+SO32	Rear Face	1	1013	-	-	0	0.947	1.07
708	LTE 12	QPSK_10M			23130	1	0	-5	0.646	
723	802.11b	-			6	-	-	-5	0.397	

FCC SAR Test Report

7. The calculation of SPLSR for (CDMA BC0 + LTE 25 + WLAN, Hotspot-Front Face) is as below:

Coordinate of Peak SAR Location (X, Y, Z) & SAR Value:

SAR 1 : CDMA BC0 (-2.93, -1, -20.72), 1.14

SAR 2 : LTE 25 (-1.7, 5, -20.5), 0.577

SAR 3 : WLAN (3.84, 0.56, -18), 0.039

Peak Location Spacing for SAR1-SAR2 = 6.1 cm

Peak Location Spacing for SAR1-SAR3 = 7.5 cm

Peak Location Spacing for SAR2-SAR3 = 7.5 cm

SPLSR for SAR1-SAR2 = $(1.14 + 0.577) / 6.1 = \mathbf{0.281}$

SPLSR for SAR1-SAR3 = $(1.14 + 0.039) / 7.5 = \mathbf{0.157}$

SPLSR for SAR2-SAR3 = $(0.577 + 0.039) / 7.5 = \mathbf{0.082}$

The volume scan for this condition is not required because all calculated SPLSR are less than 0.3.

8. The calculation of SPLSR for (CDMA BC0 + LTE 25 + WLAN, Hotspot-Rear Face) is as below:

Coordinate of Peak SAR Location (X, Y, Z) & SAR Value:

SAR 1 : CDMA BC0 (-1.49, -0.64, -20.71), 1.06

SAR 2 : LTE 25 (-2.3, 3.6, -20.5), 0.8

SAR 3 : WLAN (-3.16, 0.16, -18), 0.352

Peak Location Spacing for SAR1-SAR2 = 4.3 cm

Peak Location Spacing for SAR1-SAR3 = 3.3 cm

Peak Location Spacing for SAR2-SAR3 = 4.3 cm

SPLSR for SAR1-SAR2 = $(1.06 + 0.8) / 4.3 = \mathbf{0.433}$

SPLSR for SAR1-SAR3 = $(1.06 + 0.352) / 3.3 = \mathbf{0.428}$

SPLSR for SAR2-SAR3 = $(0.8 + 0.352) / 4.3 = \mathbf{0.268}$

Since the SPLSR is larger than 0.3, volume scan is required and the testing result is as below.

Plot No.	Band	Mode	Test Position	Separation Distance (cm)	Channel	RB	RB Offset	Cutback Power	SAR-1g (W/kg)	Multi-Band SAR-1g (W/kg)
702	CDMA BC0	RC3+SO32	Rear Face	1	1013	-	-	0	0.947	1.34
716	LTE 25	QPSK_10M			20690	1	49	-5	0.894	
723	802.11b	-			6	-	-	-5	0.397	

9. The calculation of SPLSR for (CDMA BC1 + LTE 4 + WLAN, Hotspot-Rear Face) is as below:

Coordinate of Peak SAR Location (X, Y, Z) & SAR Value:

SAR 1 : CDMA BC1 (-2.34, -6.32, -20.62), 0.525

SAR 2 : LTE 4 (-4.38, 4.68, -20.7), 0.752

SAR 3 : WLAN (-3.16, 0.16, -18), 0.352

Peak Location Spacing for SAR1-SAR2 = 11.2 cm

Peak Location Spacing for SAR1-SAR3 = 7.0 cm

Peak Location Spacing for SAR2-SAR3 = 5.4 cm

SPLSR for SAR1-SAR2 = $(0.525 + 0.752) / 11.2 = \mathbf{0.114}$

SPLSR for SAR1-SAR3 = $(0.525 + 0.352) / 7.0 = \mathbf{0.125}$

SPLSR for SAR2-SAR3 = $(0.752 + 0.352) / 5.4 = \mathbf{0.204}$

The volume scan for this condition is not required because all calculated SPLSR are less than 0.3.

FCC SAR Test Report

10. The calculation of SPLSR for (CDMA BC1 + LTE 5 + WLAN, Hotspot-Rear Face) is as below:

Coordinate of Peak SAR Location (X, Y, Z) & SAR Value:

SAR 1 : CDMA BC1 (-2.34, -6.32, -20.62), 0.525

SAR 2 : LTE 5 (1.02, 3.96, -20.58), 0.833

SAR 3 : WLAN (-3.16, 0.16, -18), 0.352

Peak Location Spacing for SAR1-SAR2 = 10.8 cm

Peak Location Spacing for SAR1-SAR3 = 7.0 cm

Peak Location Spacing for SAR2-SAR3 = 6.2 cm

SPLSR for SAR1-SAR2 = $(0.525 + 0.833) / 10.8 = 0.126$

SPLSR for SAR1-SAR3 = $(0.525 + 0.352) / 7.0 = 0.125$

SPLSR for SAR2-SAR3 = $(0.833 + 0.352) / 6.2 = 0.191$

The volume scan for this condition is not required because all calculated SPLSR are less than 0.3.

11. The calculation of SPLSR for (CDMA BC1 + LTE 12 + WLAN, Hotspot-Rear Face) is as below:

Coordinate of Peak SAR Location (X, Y, Z) & SAR Value:

SAR 1 : CDMA BC1 (-2.34, -6.32, -20.62), 0.525

SAR 2 : LTE 12 (-0.896, -5.8, -20.5), 0.78

SAR 3 : WLAN (-3.16, 0.16, -18), 0.352

Peak Location Spacing for SAR1-SAR2 = 1.5 cm

Peak Location Spacing for SAR1-SAR3 = 7.0 cm

Peak Location Spacing for SAR2-SAR3 = 6.8 cm

SPLSR for SAR1-SAR2 = $(0.525 + 0.78) / 1.5 = 0.870$

SPLSR for SAR1-SAR3 = $(0.525 + 0.352) / 7.0 = 0.125$

SPLSR for SAR2-SAR3 = $(0.78 + 0.352) / 6.8 = 0.166$

Since the SPLSR is larger than 0.3, volume scan is required and the testing result is as below.

Plot No.	Band	Mode	Test Position	Separation Distance (cm)	Channel	RB	RB Offset	Cutback Power	SAR-1g (W/kg)	Multi-Band SAR-1g (W/kg)
706	CDMA BC1	RC3+SO32	Rear Face	1	25	-	-	-7.5	0.527	0.982
708	LTE 12	QPSK_10M			23130	1	0	-5	0.646	
723	802.11b	-			6	-	-	-5	0.397	

12. The calculation of SPLSR for (CDMA BC1 + LTE 25 + WLAN, Hotspot-Rear Face) is as below:

Coordinate of Peak SAR Location (X, Y, Z) & SAR Value:

SAR 1 : CDMA BC1 (-2.34, -6.32, -20.62), 0.525

SAR 2 : LTE 25 (-2.3, 3.6, -20.5), 0.8

SAR 3 : WLAN (-3.16, 0.16, -18), 0.352

Peak Location Spacing for SAR1-SAR2 = 9.9 cm

Peak Location Spacing for SAR1-SAR3 = 7.0 cm

Peak Location Spacing for SAR2-SAR3 = 4.3 cm

SPLSR for SAR1-SAR2 = $(0.525 + 0.8) / 9.9 = 0.134$

SPLSR for SAR1-SAR3 = $(0.525 + 0.352) / 7.0 = 0.125$

SPLSR for SAR2-SAR3 = $(0.8 + 0.352) / 4.3 = 0.268$

The volume scan for this condition is not required because all calculated SPLSR are less than 0.3.

FCC SAR Test Report

13. The calculation of SPLSR for (CDMA BC15 + LTE 2 + WLAN, Hotspot-Rear Face) is as below:

Coordinate of Peak SAR Location (X, Y, Z) & SAR Value:

SAR 1 : CDMA BC15 (-1.9, -6.56, -20.62), 0.688

SAR 2 : LTE 2 (-4.1, 4.6, -20.5), 0.69

SAR 3 : WLAN (-3.16, 0.16, -18), 0.352

Peak Location Spacing for SAR1-SAR2 = 11.4 cm

Peak Location Spacing for SAR1-SAR3 = 7.3 cm

Peak Location Spacing for SAR2-SAR3 = 5.2 cm

SPLSR for SAR1-SAR2 = $(0.688 + 0.69) / 11.4 = 0.121$

SPLSR for SAR1-SAR3 = $(0.688 + 0.352) / 7.3 = 0.142$

SPLSR for SAR2-SAR3 = $(0.69 + 0.352) / 5.2 = 0.200$

The volume scan for this condition is not required because all calculated SPLSR are less than 0.3.

14. The calculation of SPLSR for (CDMA BC15 + LTE 4 + WLAN, Hotspot-Rear Face) is as below:

Coordinate of Peak SAR Location (X, Y, Z) & SAR Value:

SAR 1 : CDMA BC15 (-1.9, -6.56, -20.62), 0.688

SAR 2 : LTE 4 (-4.38, 4.68, -20.7), 0.752

SAR 3 : WLAN (-3.16, 0.16, -18), 0.352

Peak Location Spacing for SAR1-SAR2 = 11.5 cm

Peak Location Spacing for SAR1-SAR3 = 7.3 cm

Peak Location Spacing for SAR2-SAR3 = 5.4 cm

SPLSR for SAR1-SAR2 = $(0.688 + 0.752) / 11.5 = 0.125$

SPLSR for SAR1-SAR3 = $(0.688 + 0.352) / 7.3 = 0.142$

SPLSR for SAR2-SAR3 = $(0.752 + 0.352) / 5.4 = 0.204$

The volume scan for this condition is not required because all calculated SPLSR are less than 0.3.

15. The calculation of SPLSR for (CDMA BC15 + LTE 5 + WLAN, Hotspot-Rear Face) is as below:

Coordinate of Peak SAR Location (X, Y, Z) & SAR Value:

SAR 1 : CDMA BC15 (-1.9, -6.56, -20.62), 0.688

SAR 2 : LTE 5 (1.02, 3.96, -20.58), 0.833

SAR 3 : WLAN (-3.16, 0.16, -18), 0.352

Peak Location Spacing for SAR1-SAR2 = 10.9 cm

Peak Location Spacing for SAR1-SAR3 = 7.3 cm

Peak Location Spacing for SAR2-SAR3 = 6.2 cm

SPLSR for SAR1-SAR2 = $(0.688 + 0.833) / 10.9 = 0.140$

SPLSR for SAR1-SAR3 = $(0.688 + 0.352) / 7.3 = 0.142$

SPLSR for SAR2-SAR3 = $(0.833 + 0.352) / 6.2 = 0.191$

The volume scan for this condition is not required because all calculated SPLSR are less than 0.3.

FCC SAR Test Report

16. The calculation of SPLSR for (CDMA BC15 + LTE 12 + WLAN, Hotspot-Rear Face) is as below:

Coordinate of Peak SAR Location (X, Y, Z) & SAR Value:

SAR 1 : CDMA BC15 (-1.9, -6.56, -20.62), 0.688

SAR 2 : LTE 12 (-0.896, -5.8, -20.5), 0.78

SAR 3 : WLAN (-3.16, 0.16, -18), 0.352

Peak Location Spacing for SAR1-SAR2 = 1.3 cm

Peak Location Spacing for SAR1-SAR3 = 7.3 cm

Peak Location Spacing for SAR2-SAR3 = 6.8 cm

SPLSR for SAR1-SAR2 = $(0.688 + 0.78) / 1.3 = 1.130$

SPLSR for SAR1-SAR3 = $(0.688 + 0.352) / 7.3 = 0.142$

SPLSR for SAR2-SAR3 = $(0.78 + 0.352) / 6.8 = 0.166$

Since the SPLSR is larger than 0.3, volume scan is required and the testing result is as below.

Plot No.	Band	Mode	Test Position	Separation Distance (cm)	Channel	RB	RB Offset	Cutback Power	SAR-1g (W/kg)	Multi-Band SAR-1g (W/kg)
704	CDMA BC15	RC3+SO32	Rear Face	1	875	-	-	-7.5	0.739	1.22
708	LTE 12	QPSK_10M			23130	1	0	-5	0.646	
723	802.11b	-			6	-	-	-5	0.397	

17. The calculation of SPLSR for (CDMA BC15 + LTE 25 + WLAN, Hotspot-Rear Face) is as below:

Coordinate of Peak SAR Location (X, Y, Z) & SAR Value:

SAR 1 : CDMA BC15 (-1.9, -6.56, -20.62), 0.688

SAR 2 : LTE 25 (-2.3, 3.6, -20.5), 0.8

SAR 3 : WLAN (-3.16, 0.16, -18), 0.352

Peak Location Spacing for SAR1-SAR2 = 10.2 cm

Peak Location Spacing for SAR1-SAR3 = 7.3 cm

Peak Location Spacing for SAR2-SAR3 = 4.3 cm

SPLSR for SAR1-SAR2 = $(0.688 + 0.8) / 10.2 = 0.146$

SPLSR for SAR1-SAR3 = $(0.688 + 0.352) / 7.3 = 0.142$

SPLSR for SAR2-SAR3 = $(0.8 + 0.352) / 4.3 = 0.268$

The volume scan for this condition is not required because all calculated SPLSR are less than 0.3.

Bluetooth standalone SAR and WWAN/Bluetooth simultaneous transmission SAR are not required because Bluetooth maximum power is less than P_{Ref} and the separation distance between WWAN/Bluetooth antenna is less than 2.5 cm and the maximum WWAN SAR is less than 1.2 W/kg. WLAN and Bluetooth is share the same antenna and they cannot transmit simultaneously.



5. Calibration of Test Equipment

Equipment	Manufacturer	Model	SN	Cal. Date	Cal. Interval
System Validation Kit	SPEAG	D750V3	1013	Apr. 25, 2012	Annual
System Validation Kit	SPEAG	D835V2	4d021	Apr. 20, 2012	Annual
System Validation Kit	SPEAG	D1750V2	1023	Jun. 20, 2012	Annual
System Validation Kit	SPEAG	D1900V2	5d036	Jan. 26, 2012	Annual
System Validation Kit	SPEAG	D2450V2	737	Jan. 24, 2012	Annual
Dosimetric E-Field Probe	SPEAG	EX3DV4	3590	Feb. 23, 2012	Annual
Dosimetric E-Field Probe	SPEAG	EX3DV4	3650	Oct. 26, 2011	Annual
Dosimetric E-Field Probe	SPEAG	EX3DV4	3864	Jul. 19, 2012	Annual
Data Acquisition Electronics	SPEAG	DAE3	579	Apr. 27, 2012	Annual
Data Acquisition Electronics	SPEAG	DAE4	861	Aug. 23, 2012	Annual
Data Acquisition Electronics	SPEAG	DAE4	910	Dec. 07, 2011	Annual
Data Acquisition Electronics	SPEAG	DAE4	1277	Jul. 19, 2012	Annual
SAM Phantom	SPEAG	QD000P40CD	TP-1652	N/A	N/A
SAM Phantom	SPEAG	QD000P40CD	TP-1654	N/A	N/A
SAM Phantom	SPEAG	QD000P40CD	TP-1485	N/A	N/A
SAM Phantom	SPEAG	QD000P40CD	TP-1202	N/A	N/A
SAM Phantom	SPEAG	QD000P40CD	TP-1653	N/A	N/A
ELI Phantom	SPEAG	QDOVA001B	TP-1043	N/A	N/A
Radio Communication Tester	Agilent	E5515C	MY50260642	Oct. 25, 2011	Biennial
Radio Communication Analyzer	Anritsu	MT8820C	6201010284	Aug. 01, 2011	Biennial
ENA Series Network Analyzer	Agilent	E5071C	MY46214281	May 14, 2012	Annual
MXG Analog Signal Generator	Agilent	N5181A	MY50143868	May 06, 2012	Annual
Power Meter	Anritsu	ML2495A	1218009	May 07, 2012	Annual
Power Sensor	Anritsu	MA2411B	1207252	May 07, 2012	Annual
EXA Spectrum Analyzer	Agilent	N9010A	MY52100136	Apr. 23, 2012	Annual
Dielectric Probe Kit	Agilent	85070D	E2-020018	May 14, 2012	Annual
Thermometer	YFE	YF-160A	110600361	Feb. 21, 2012	Annual
Directional Coupler	Woken	0110A056020-10	11122702	Apr. 19, 2012	Annual
Power Amplifier	AR	5S1G4	0339656	Apr. 23, 2012	Annual
Power Amplifier	Mini-Circuit	ZVE-8G	001000422	Apr. 23, 2012	Annual
Attenuator	Woken	00800A1G01L-03	N/A	Apr. 19, 2012	Annual

6. Measurement Uncertainty

Error Description	Uncertainty Value (±%)	Probability Distribution	Divisor	Ci (1g)	Standard Uncertainty (1g)	Vi
Measurement System						
Probe Calibration	6.0	Normal	1	1	± 6.0 %	∞
Axial Isotropy	4.7	Rectangular	√3	0.7	± 1.9 %	∞
Hemispherical Isotropy	9.6	Rectangular	√3	0.7	± 3.9 %	∞
Boundary Effects	1.0	Rectangular	√3	1	± 0.6 %	∞
Linearity	4.7	Rectangular	√3	1	± 2.7 %	∞
System Detection Limits	1.0	Rectangular	√3	1	± 0.6 %	∞
Readout Electronics	0.6	Normal	1	1	± 0.6 %	∞
Response Time	0.0	Rectangular	√3	1	± 0.0 %	∞
Integration Time	1.7	Rectangular	√3	1	± 1.0 %	∞
RF Ambient Noise	3.0	Rectangular	√3	1	± 1.7 %	∞
RF Ambient Reflections	3.0	Rectangular	√3	1	± 1.7 %	∞
Probe Positioner	0.5	Rectangular	√3	1	± 0.3 %	∞
Probe Positioning	2.9	Rectangular	√3	1	± 1.7 %	∞
Max. SAR Eval.	2.3	Rectangular	√3	1	± 1.3 %	∞
Test Sample Related						
Device Positioning	3.9	Normal	1	1	± 3.9 %	31
Device Holder	2.7	Normal	1	1	± 2.7 %	19
Power Drift	5.0	Rectangular	√3	1	± 2.9 %	∞
Phantom and Setup						
Phantom Uncertainty	4.0	Rectangular	√3	1	± 2.3 %	∞
Liquid Conductivity (Target)	5.0	Rectangular	√3	0.64	± 1.8 %	∞
Liquid Conductivity (Meas.)	5.0	Normal	1	0.64	± 3.2 %	29
Liquid Permittivity (Target)	5.0	Rectangular	√3	0.6	± 1.7 %	∞
Liquid Permittivity (Meas.)	5.0	Normal	1	0.6	± 3.0 %	29
Combined Standard Uncertainty					± 11.7 %	
Expanded Uncertainty (K=2)					± 23.4 %	

Uncertainty budget for frequency range 300 MHz to 3 GHz



7. Information on the Testing Laboratories

We, Bureau Veritas Consumer Products Services (H.K.) Ltd., Taoyuan Branch, were founded in 1988 to provide our best service in EMC, Radio, Telecom and Safety consultation. Our laboratories are accredited and approved according to ISO/IEC 17025.

Copies of accreditation and authorization certificates of our laboratories obtained from approval agencies can be downloaded from our web site. If you have any comments, please feel free to contact us at the following:

Taiwan HwaYa EMC/RF/Safety/Telecom Lab:

Add: No. 19, Hwa Ya 2nd Rd, Wen Hwa Vil., Kwei Shan Hsiang, Taoyuan Hsien 333, Taiwan, R.O.C.

Tel: 886-3-318-3232

Fax: 886-3-327-0892

Taiwan LinKo EMC/RF Lab:

Add: No. 47, 14th Ling, Chia Pau Vil., Linkou Dist., New Taipei City 244, Taiwan, R.O.C.

Tel: 886-2-2605-2180

Fax: 886-2-2605-1924

Taiwan HsinChu EMC/RF Lab:

Add: No. 81-1, Lu Liao Keng, 9th Ling, Wu Lung Vil., Chiung Lin Township, Hsinchu County 307, Taiwan, R.O.C.

Tel: 886-3-593-5343

Fax: 886-3-593-5342

Email: service.adt@tw.bureauveritas.com

Web Site: www.adt.com.tw

The road map of all our labs can be found in our web site also.

---END---