

FCC 47 CFR PART 15 SUBPART C

Product Type : Motorola XOOM Family Edition
Applicant : Motorola Mobility, Inc.
Address : 8000 W. Sunrise Blvd. Plantation Florida United States
33322
Trade Name : MOTOROLA
Model Number : MZ505
Test Specification : FCC 47 CFR PART 15 SUBPART C: Oct., 2010
Canada RSS-210 ISSUE 8: Dec., 2010
Canada RSS-Gen ISSUE 3: Dec., 2010
ANSI C63.4-2009
Issue Date : Jul. 27, 2011

Issue by

A Test Lab Techno Corp.
No. 140-1, Changan Street, Bade City,
Taoyuan County 334, Taiwan R.O.C.
Tel : +86-3-2710188 / Fax : +86-3-2710190



Taiwan Accreditation Foundation accreditation number: 1330

Note: This report shall not be reproduced except in full, without the written approval of A Test Lab Techno Corp. This document may be altered or revised by A Test Lab Techno Corp. personnel only, and shall be noted in the revision section of the document. The client should not use it to claim product endorsement by TAF, or any government agencies. The test results in the report only apply to the tested sample.

Revision History

Rev.	Issue Date	Revisions	Revised By
00	Jul. 27, 2011	Initial Issue	

Verification of Compliance

Issued Date: 07/27/2011

Product Type : Motorola XOOM Family Edition
Applicant : Motorola Mobility, Inc.
Address : 8000 W. Sunrise Blvd. Plantation Florida United States
33322

Trade Name : MOTOROLA
Model Number : MZ505
FCC ID : IHDP56MP1
IC ID : 1090-P56MP1
EUT Rated Voltage : DC 5.0V, 2.0A
Test Voltage : 120 Vac / 60 Hz
Applicable : FCC 47 CFR PART 15 SUBPART C: Oct., 2010
Standard : Canada RSS-210 ISSUE 8: Dec., 2010
Canada RSS-Gen ISSUE 3: Dec., 2010
ANSI C63.4-2009

Test Result : Complied
Performing Lab. : A Test Lab Techno Corp.

No. 140-1, Changan Street, Bade City,
Taoyuan County 334, Taiwan R.O.C.

Tel : +86-3-2710188 / Fax : +86-3-2710190

Taiwan Accreditation Foundation accreditation number:

1330

<http://www.atl-lab.com.tw/e-index.htm>



The above equipment was tested by A Test Lab Techno Corp. The test data, data evaluation, test procedures, and equipment configurations shown in this report were made in accordance with the procedures given in ANSI C63.4: 2009 and the energy emitted by the sample tested as described in this report is in compliance with the requirements of FCC Rules Part 15.207, 15.209, 15.247 .

The test results of this report relate only to the tested sample identified in this report.

Approved By : Miller Lee
(Manager) (Miller Lee)

Reviewed By : Gary Wu
(Testing Engineer) (Gary Wu)

TABLE OF CONTENTS

1	General Information	6
2	EUT Description	7
3	Test Methodology.....	8
	3.1. Mode of Operation	8
	3.2. EUT Exercise Software.....	8
	3.3. Configuration of Test System Details	9
	3.4. Test Site Environment.....	10
4	Conducted Emission Measurement.....	11
	4.1. Limit.....	11
	4.2. Test Instruments	11
	4.3. Test Setup.....	11
	4.4. Test Procedure	12
	4.5. Test Result.....	13
5	Radiated Interference Measurement.....	15
	5.1. Limit.....	15
	5.2. Test Instruments	15
	5.3. Setup	16
	5.4. Test Procedure	17
	5.5. Test Result.....	19
6	Maximum Conducted Output Power Measurement.....	27
	6.1. Limit.....	27
	6.2. Test Setup.....	27
	6.3. Test Instruments	27
	6.4. Test Procedure	27
	6.5. Test Result.....	28
7	6dB RF Bandwidth Measurement	29
	7.1. Limit.....	29
	7.2. Test Setup.....	29
	7.3. Test Instruments	29
	7.4. Test Procedure	29
	7.5. Test Result.....	30
	7.6. Test Graphs	31

8	Maximum Power Density Measurement	34
8.1.	Limit.....	34
8.2.	Test Setup.....	34
8.3.	Test Instruments	34
8.4.	Test Procedure	34
8.5.	Test Result.....	35
8.6.	Test Graphs	36
9	Out of Band Conducted Emissions Measurement	39
9.1.	Limit.....	39
9.2.	Test Setup.....	39
9.3.	Test Instruments	39
9.4.	Test Procedure	39
9.5.	Test Graphs	40
10	Band Edges Measurement.....	43
10.1.	Limit.....	43
10.2.	Test Setup.....	43
10.3.	Test Instruments	43
10.4.	Test Procedure	44
10.5.	Test Result.....	45
11	99 % Occupied Bandwidth Measurement.....	57
11.1.	Limit.....	57
11.2.	Test Setup.....	57
11.3.	Test Instruments	57
11.4.	Test Procedure	57
11.5.	Test Result.....	58
11.6.	Test Graphs	59
12	Antenna Measurement	62
12.1.	Limit.....	62
12.2.	Antenna Connector Construction.....	62

1 General Information

1.1 Summary of Test Result

Standard		Item	Result	Remark
15.247	RSS-GEN			
15.207	7.2.2	AC Power Conducted Emission	PASS	-----
-----	6	Receiver Radiated Emissions	PASS	-----
Standard		Item	Result	Remark
15.247	RSS-210			
15.247(d)	A8.5	Transmitter Radiated Emissions	PASS	-----
15.247(b)(3)	A8.4	Max. Output Power	PASS	-----
15.247(a)(2)	A8.2 (a)	6dB RF Bandwidth	PASS	-----
15.247(e)	A8.2 (b)	Power Spectral Density	PASS	-----
15.247(c)	A8.5	Out of Band Conducted Spurious Emission	PASS	-----
15.247(d)	A8.5	Band Edge Measurement	PASS	-----
15.247(c)	A8.5	Occupied Bandwidth Measurement	PASS	-----
15.203	-	Antenna Requirement	PASS	-----

The test results of this report relate only to the tested sample(s) identified in this report. Manufacturer or whom it may concern should recognize the pass or fail of the test result.

1.2 Measurement Uncertainty

Conducted Emission

The measurement uncertainty is evaluated as ± 2.24 dB.

Radiated Emission

The measurement uncertainty of 30 MHz - 1GHz is evaluated as ± 3.072 dB.

2 EUT Description

Product	:	Motorola XOOM Family Edition
Trade Name	:	MOTOROLA
Model No.	:	MZ505
Applicant	:	Motorola Mobility, Inc. 8000 W. Sunrise Blvd. Plantation Florida United States 33322
Manufacturer	:	Compal Information Technology (Kunshan) Co., Ltd. No.58, First Avenue, A Zone, Kunshan Comprehensive Free Trade Zone, Kunshan, Jiangsu, China
FCC ID	:	IHDP56MP1
IC ID	:	109O-P56MP1
Frequency Range	:	2412 ~ 2462 MHz
Modulation Type	:	IEEE 802.11b:DSSS(DQPSK, DBPSK) IEEE 802.11g:DSSS(DQPSK, DBPSK)+ OFDM(QPSK, BPSK, 16-QAM, 64-QAM) draft 802.11n Standard-20MHz channel mode: OFDM(6.5, 13, 19.5, 26, 39, 52, 58.5 and 65.0 Mbps)
Antenna Type	:	PIFA Type
Antenna Gain	:	0.75 dBi
RF Output Power	:	IEEE 802.11b: 0.055 W / 17.42 dBm IEEE 802.11g: 0.197 W / 22.94 dBm draft 802.11n Standard-20MHz: 0.164 W / 22.15 dBm
Component		
Power Adapter	:	TPT, MII050200 Input:100-240Vac, 50-60Hz, 0.3A Output: 5.0Vdc, 2.0A Cable out: Shielded, 1.2 m

3 Test Methodology

3.1. Mode of Operation

Decision of Test ATL has verified the construction and function in typical operation. All the test modes were carried out with the EUT in normal operation, which was shown in this test report and defined as:

Test Mode
Mode 1: Normal Operation Mode
Mode 2: IEEE 802.11b Link Mode
Mode 3: IEEE 802.11g Link Mode
Mode 4: draft 802.11n Standard-20MHz Link Mode
Mode 5: Receiver Mode

By preliminary testing and verifying three axis (X, Y and Z) position of EUT transmitted status, it was found that "X axis" position was the worst, then the final test was executed the worst condition and test data were recorded in this report.

Software used to control the EUT for staying in continuous transmitting mode was programmed.

After verification, all tests were carried out with the worst case test modes as shown below except radiated spurious emission below 1GHz and power line conducted emissions below 30MHz, which worst case was in normal link mode only.

IEEE 802.11b mode:

Channel Low (2412MHz), Channel Mid (2437MHz) and Channel High (2462MHz) with 1Mbps data rate were chosen for full testing.

IEEE 802.11g mode:

Channel Low (2412MHz), Channel Mid (2437MHz) and Channel High (2462MHz) with 54Mbps data rate were chosen for full testing.

draft 802.11n Standard-20 MHz Channel mode:

Channel Low (2412MHz), Channel Mid (2437MHz) and Channel High (2462MHz) with 6.5Mbps data rate were chosen for full testing.

3.2. EUT Exercise Software

1.	Setup the EUT shown on 3.3.
2.	Turn on the power of all equipment.
3.	Turn on Wi-Fi function link to AP.
4.	EUT run test program.

3.3. Configuration of Test System Details

Conducted Emission

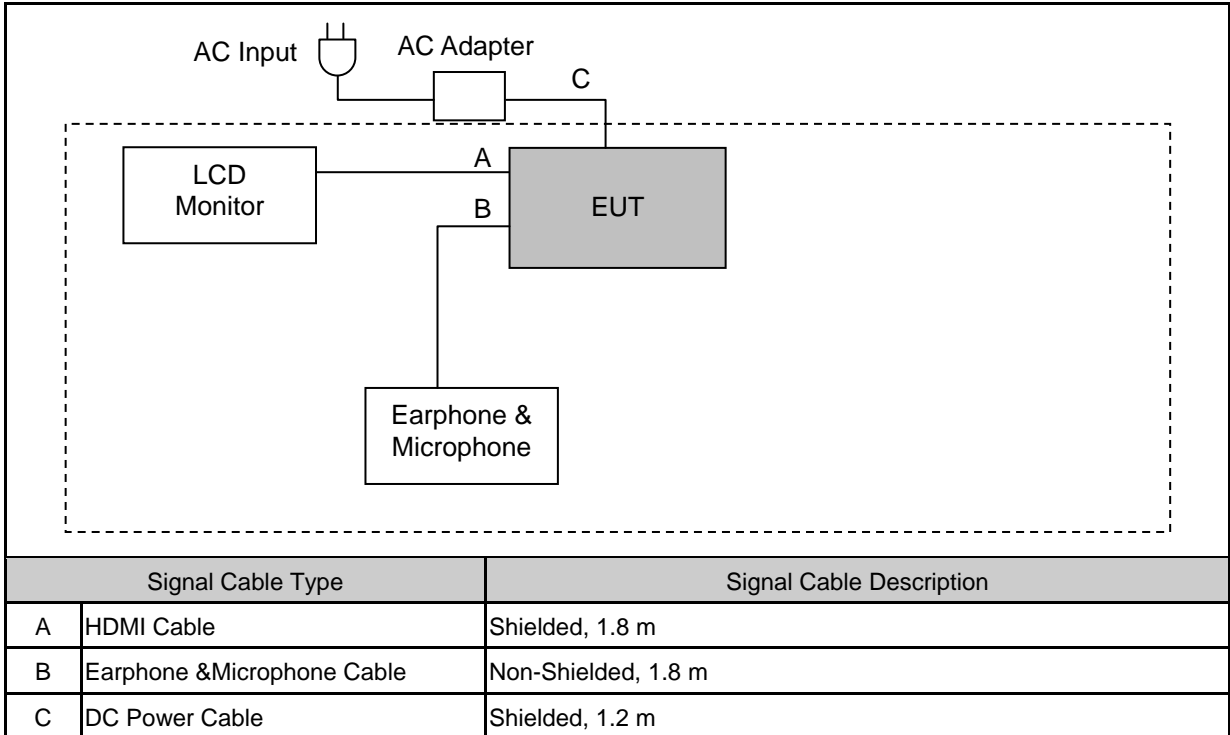

Radiated Emission

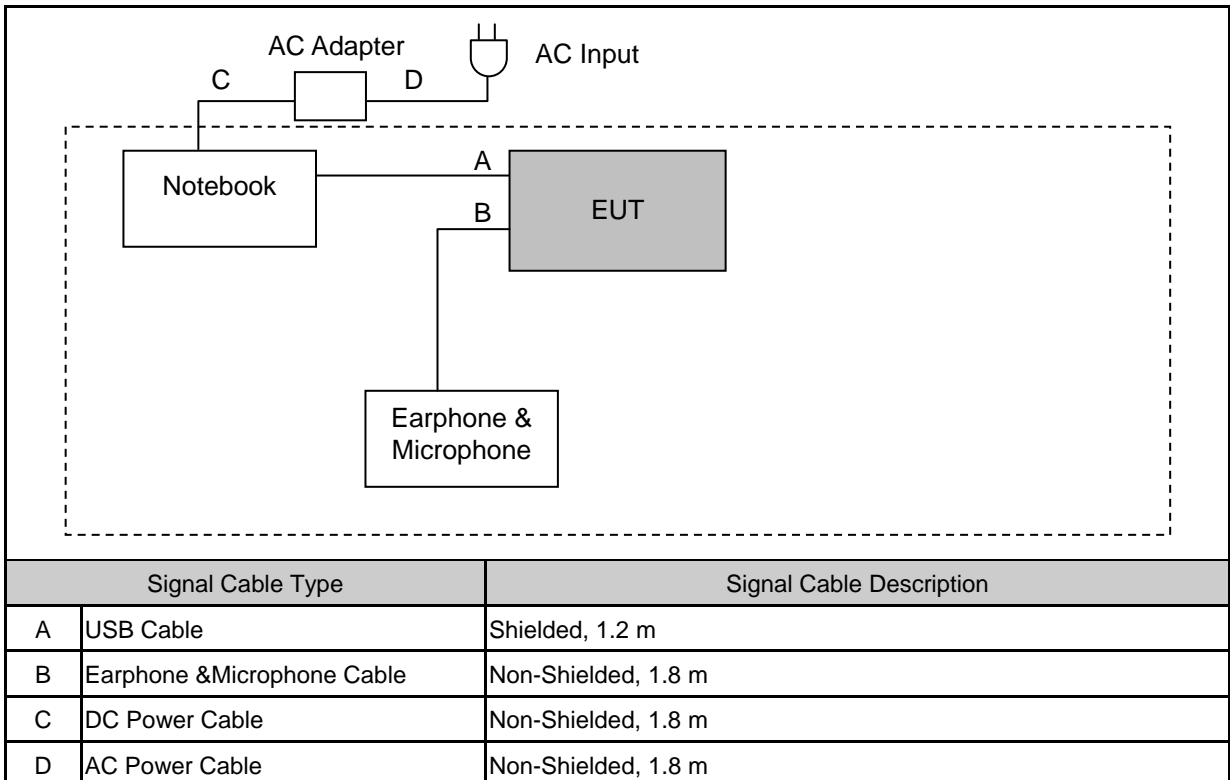

3.4. Test Site Environment

Items	Required (IEC 68-1)	Actual
Temperature (°C)	15-35	25
Humidity (%RH)	25-75	50
Barometric pressure (mbar)	860-1060	950

4 Conducted Emission Measurement

4.1. Limit

Frequency (MHz)	Quasi-peak	Average
0.15 - 0.5	66 to 56	56 to 46
0.50 - 5.0	56	46
5.0 - 30.0	60	50

4.2. Test Instruments

Describe	Manufacturer	Model Number	Serial Number	Cal. Date	Remark
Test Receiver	R&S	ESCI	100367	06/30/2011	(1)
LISN	R&S	ENV216	101040	03/04/2011	(1)
LISN	R&S	ENV216	101041	03/04/2011	(1)
Test Site	ATL	TE05	TE05	N.C.R.	-----

Remark: (1) Calibration period 1 year. (2) Calibration period 2 years.

NOTE: N.C.R. = No Calibration Request.

4.3. Test Setup

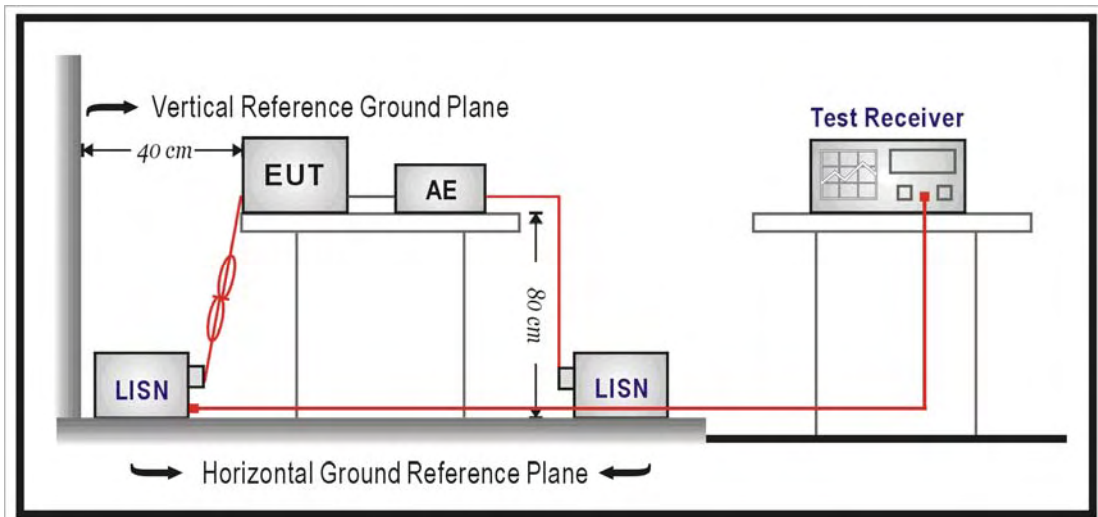

4.4. Test Procedure

The power line conducted emission measurements were performed in a shielded enclosure. The EUT was assembled on a wooden table which is 80 centimeters high, was placed 40 centimeters from the back wall and at least 1 meter from the sidewall.

Power was fed to the EUT from the public utility power grid through a line filter and EMCO Model 3162/2 SH Line Impedance Stabilization Networks (LISN). The LISN housing, measuring instrumentation case, ground plane, etc., were electrically bonded together at the same RF potential. The Spectrum analyzer was connected to the AC line through an isolation transformer. The 50-ohm output of the LISN was connected to the spectrum analyzer directly. Conducted emission levels were in the CISPR quasi-peak detection mode. The analyzer's 6 dB bandwidth was set to 9 KHz. No post-detector video filter was used.

The spectrum was scanned from 150 KHz to 30 MHz. The physical arrangement of the test system and associated cabling was varied (within the scope of arrangements likely to be encountered in actual use) to determine the effect on the unit's emanations in amplitude and frequency. All spurious emission frequencies were observed. The highest emission amplitudes relative to the appropriate limit were measured and have been recorded in paragraph 4.1.

4.5. Test Result

Standard:	FCC Part 15C	Line:	L1
Test item:	Conducted Emission	Power:	AC 120V/60Hz
Model Number:	MZ505	Temp.(°C)/Hum.(%RH):	26(°C)/60%RH
Mode:	Mode 1	Date:	07/04/2011
		Test By:	Gary Wu
Description:			

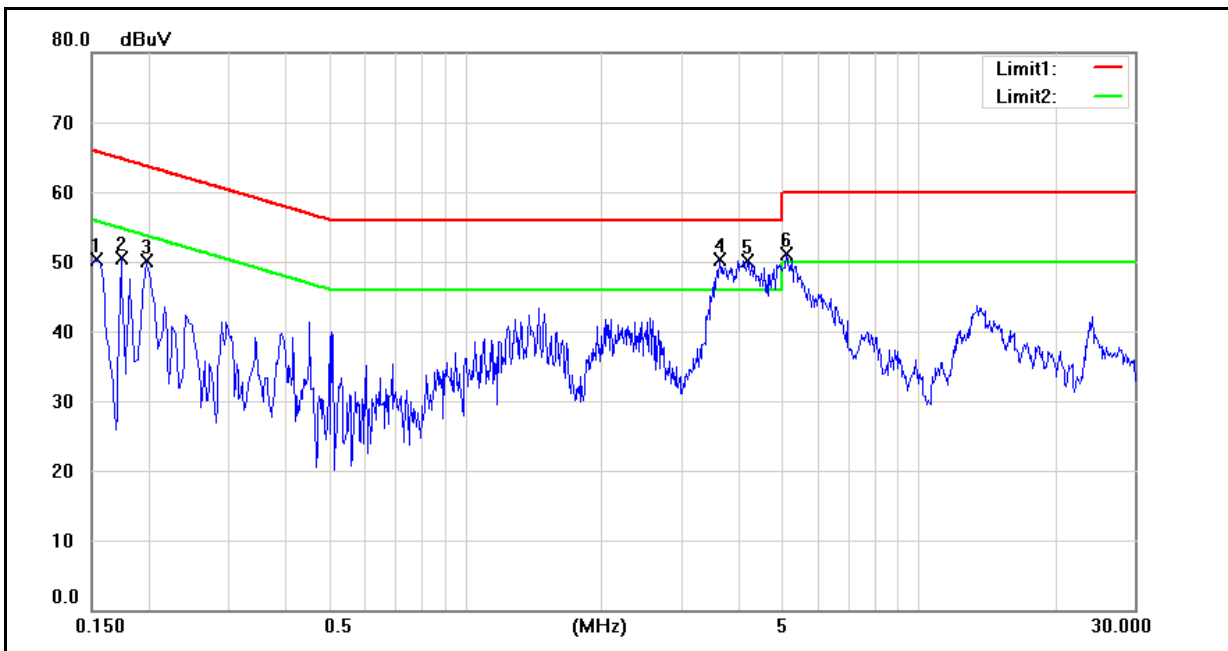

No.	Frequency (MHz)	QP reading (dBuV)	AVG reading (dBuV)	Correction factor (dB)	QP result (dBuV)	AVG result (dBuV)	QP limit (dBuV)	AVG limit (dBuV)	QP margin (dB)	AVG margin (dB)	Remark
1	0.1540	37.65	23.79	10.07	47.72	33.86	65.78	55.78	-18.06	-21.92	Pass
2	0.1740	34.58	12.65	10.06	44.64	22.71	64.77	54.77	-20.13	-32.06	Pass
3	0.1980	35.09	26.84	10.05	45.14	36.89	63.69	53.69	-18.55	-16.80	Pass
4	3.6580	35.15	28.40	9.80	44.95	38.20	56.00	46.00	-11.05	-7.80	Pass
5	4.2020	35.78	28.89	9.81	45.59	38.70	56.00	46.00	-10.41	-7.30	Pass
6	5.1220	35.83	29.04	9.80	45.63	38.84	60.00	50.00	-14.37	-11.16	Pass

Standard:	FCC Part 15C	Line:	N
Test item:	Conducted Emission	Power:	AC 120V/60Hz
Model Number:	MZ505	Temp.(°C)/Hum.(%RH):	26(°C)/60%RH
Mode:	Mode 1	Date:	07/04/2011
		Test By:	Gary Wu
Description:			

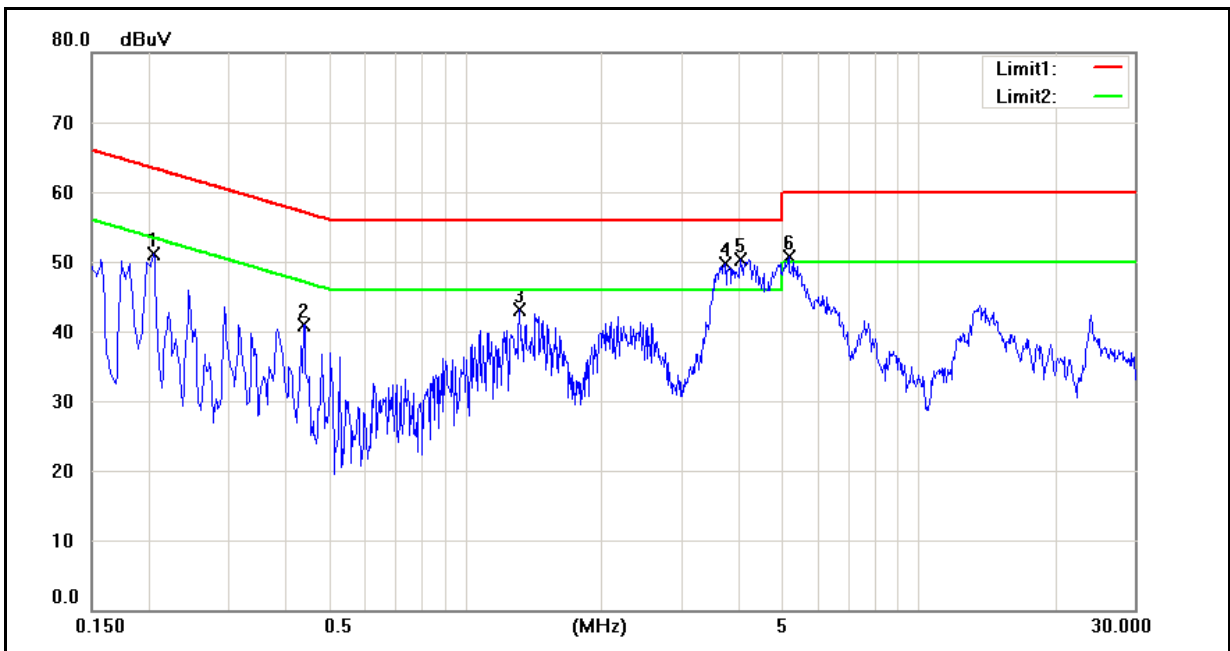

No.	Frequency (MHz)	QP reading (dBuV)	AVG reading (dBuV)	Correction factor (dB)	QP result (dBuV)	AVG result (dBuV)	QP limit (dBuV)	AVG limit (dBuV)	QP margin (dB)	AVG margin (dB)	Remark
1	0.2060	33.16	20.70	10.13	43.29	30.83	63.37	53.37	-20.08	-22.54	Pass
2	0.4420	23.53	13.04	10.03	33.56	23.07	57.02	47.02	-23.46	-23.95	Pass
3	1.3180	27.28	19.19	9.77	37.05	28.96	56.00	46.00	-18.95	-17.04	Pass
4	3.7540	34.79	27.85	9.87	44.66	37.72	56.00	46.00	-11.34	-8.28	Pass
5	4.0660	35.76	28.78	9.88	45.64	38.66	56.00	46.00	-10.36	-7.34	Pass
6	5.1780	35.46	28.81	9.86	45.32	38.67	60.00	50.00	-14.68	-11.33	Pass

5 Radiated Interference Measurement

5.1. Limit

Frequency Range (MHz)	Peak (dBuV)
30 to 88	40
88 to 216	43.5
216 to 960	46
Above 960	54

5.2. Test Instruments

3 Meter Chamber					
Equipment	Manufacturer	Model Number	Serial Number	Cal. Date	Remark
RF Pre-selector	Agilent	N9039A	MY46520256	01/18/2011	(2)
Spectrum Analyzer	Agilent	E4446A	MY46180578	01/18/2011	(1)
Pre Amplifier	Agilent	8449B	3008A02237	02/23/2011	(1)
Pre Amplifier	Agilent	8447D	2944A10961	02/23/2011	(1)
Broadband Antenna (30MHz~1GHz)	SCHWARZBECK MESS-ELEKTRONIK	VULB9163	9163-270	08/02/2010	(1)
Horn Antenna (1~18GHz)	SCHWARZBECK MESS-ELEKTRONIK	BBHA9120D	9120D-550	06/29/2011	(1)
Horn Antenna (18~40GHz)	SCHWARZBECK MESS-ELEKTRONIK	BBHA9170	9170-320	06/28/2011	(1)
Test Site	ATL	TE01	888001	07/30/2010	(1)

Remark: (1) Calibration period 1 year. (2) Calibration period 2 years.

NOTE: N.C.R. = No Calibration Request.

5.3. Setup

Below 1GHz

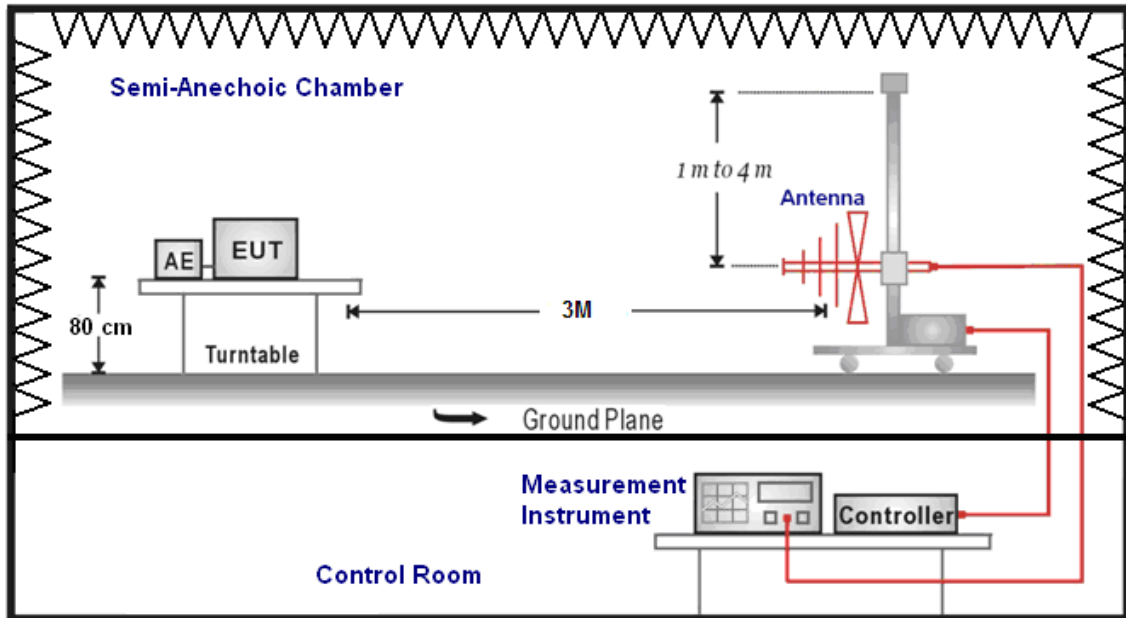

Above 1GHz

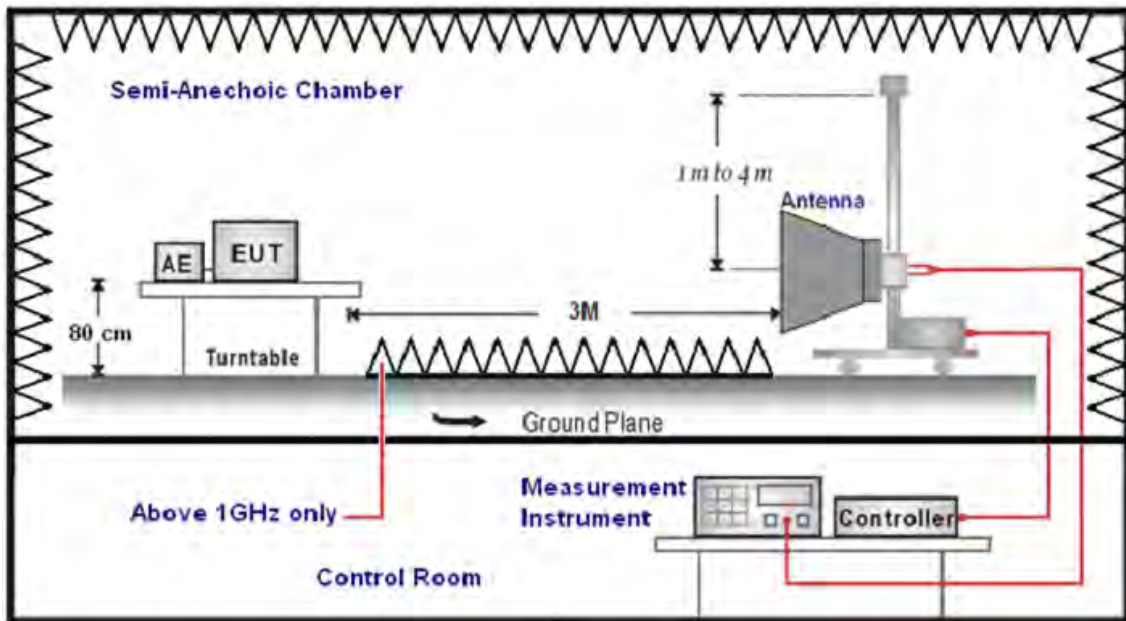

5.4. Test Procedure

Final radiation measurements were made on a three-meter, Semi Anechoic Chamber. The EUT system was placed on a nonconductive turntable which is 0.8 meters height, top surface 1.0 x 1.5 meter. The spectrum was examined from 250 MHz to 2.5 GHz in order to cover the whole spectrum below 10th harmonic which could generate from the EUT. During the test, EUT was set to transmit continuously & Measurements spectrum range from 30 MHz to 26.5 GHz is investigated.

For measurements below 1 GHz the resolution bandwidth is set to 100 kHz for peak detection measurements or 120 kHz for quasi-peak detection measurements. Peak detection is used unless otherwise noted as quasi-peak.

For measurements above 1 GHz the resolution bandwidth is set to 1 MHz, and then the video bandwidth is set to 1 MHz for peak measurements and 10 Hz for average measurements.

A nonconductive material surrounded the EUT to supporting the EUT for standing on three orthogonal planes. At each condition, the EUT was rotated 360 degrees, and the antenna was raised and lowered from one to four meters to find the maximum emission levels. Measurements were taken using both horizontal and vertical antenna polarization.

SCHWARZBECK MESS-ELEKTRONIK Biconilog Antenna (model VULB9163) at 3 Meter and the SCHWARZBECK Double Ridged Guide Antenna (model BBHA9120D&9170) was used in frequencies 1 – 26.5 GHz at a distance of 1 meter. All test results were extrapolated to equivalent signal at 3 meters utilizing an inverse linear distance extrapolation Factor (20dB/decade).

For testing above 1GHz, the emission level of the EUT in peak mode was 20dB lower than average limit (that means the emission level in peak mode also complies with the limit in average mode), then testing will be stopped and peak values of EUT will be reported, otherwise, the emissions will be measured in average mode again and reported.

Appropriate preamplifiers were used for improving sensitivity and precautions were taken to avoid overloading or desensitizing the spectrum analyzer. No post – detector video filters were used in the test.

The spectrum analyzer's 6 dB bandwidth was set to 1 MHz, and the analyzer was operated in the peak detection mode, for frequencies both below and up 1 GHz. The average levels were obtained by subtracting the duty cycle correction factor from the peak readings.

The following procedures were used to convert the emission levels measured in decibels referenced to 1 microvolt (dBuV) into field intensity in micro volts pre meter (uV/m).

The actual field intensity in decibels referenced to 1 microvolt in to field intensity in micro volts per meter (dBuV/m).

The actual field intensity in referenced to 1 microvolt per meter (dBuV/m) is determined by algebraically adding the measured reading in dBuV, the antenna factor (dB), and cable loss (dB) and Subtracting the gain of preamplifier (dB) is auto calculate in spectrum analyzer.

(1) $\text{Amplitude (dBuV/m)} = \text{FI (dBuV)} + \text{AF (dBuV)} + \text{CL (dBuV)} - \text{Gain (dB)}$

FI= Reading of the field intensity.

AF= Antenna factor.

CL= Cable loss.

P.S Amplitude is auto calculate in spectrum analyzer.

(2) $\text{Actual Amplitude (dBuV/m)} = \text{Amplitude (dBuV)} - \text{Dis (dB)}$

The FCC specified emission limits were calculated according the EUT operating frequency and by following linear interpolation equations:

(a) For fundamental frequency : Transmitter Output < +30dBm

(b) For spurious frequency : Spurious emission limits = fundamental emission limit /10

5.5. Test Result

Below 1GHz

Standard:	FCC Part 15C	Test Distance:	3m
Test item:	Radiated Emission	Power:	AC 120V/60Hz
Model Number:	MZ505	Temp.(°C)/Hum.(%RH):	26(°C)/60%RH
Mode:	Mode 1	Date:	07/14/2011
Ant.Polar.:	Horizontal	Test By:	Gary Wu

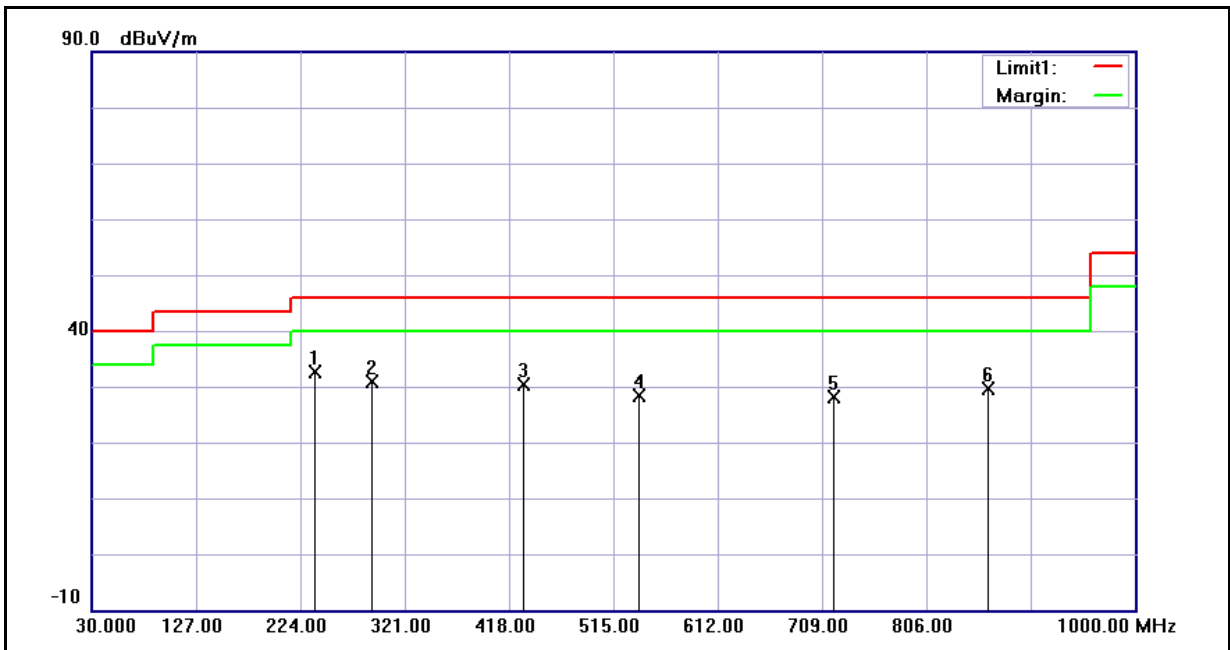

No.	Frequency (MHz)	Reading (dBuV)	Correct Factor(dB/m)	Result (dBuV/m)	Limit (dBuV/m)	Margin (dB)	Remark
1	238.5000	44.74	-12.23	32.51	46.00	-13.49	QP
2	290.0000	41.57	-10.80	30.77	46.00	-15.23	QP
3	432.0000	38.45	-8.16	30.29	46.00	-15.71	QP
4	540.0000	34.74	-6.34	28.40	46.00	-17.60	QP
5	720.0000	31.11	-2.92	28.19	46.00	-17.81	QP
6	864.0000	30.16	-0.65	29.51	46.00	-16.49	QP

Standard:	FCC Part 15C	Test Distance:	3m
Test item:	Radiated Emission	Power:	AC 120V/60Hz
Model Number:	MZ505	Temp.(°C)/Hum.(%RH):	26(°C)/60%RH
Mode:	Mode 1	Date:	07/14/2011
Ant.Polar.:	Vertical	Test By:	Gary Wu

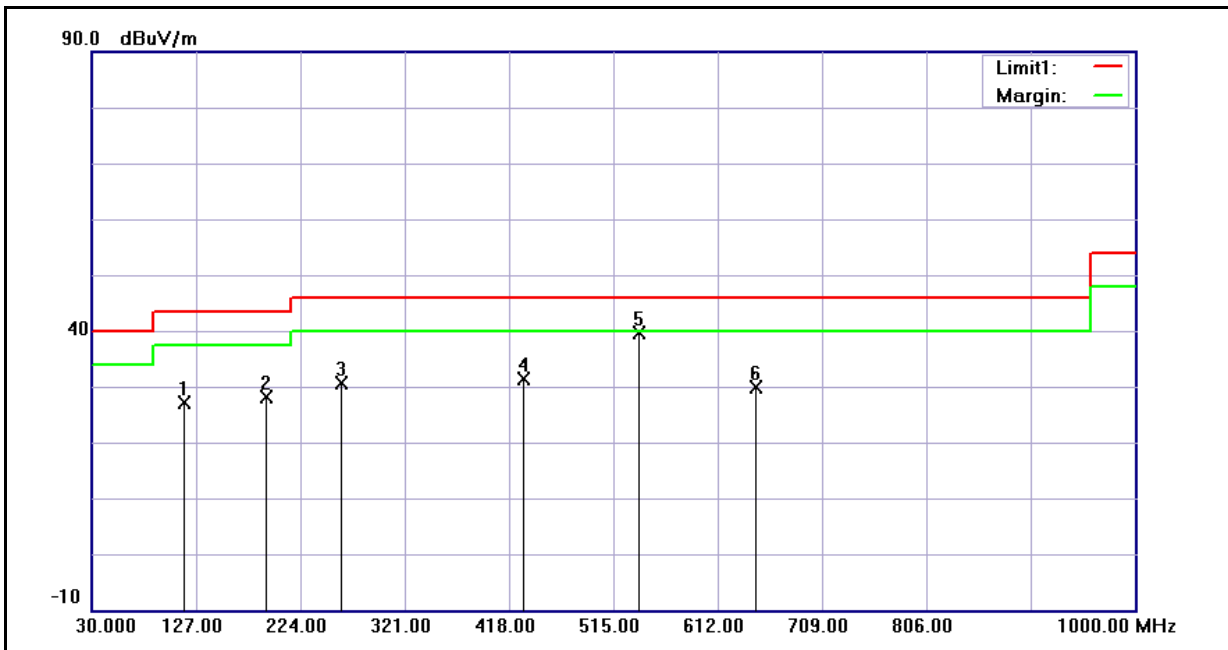

No.	Frequency (MHz)	Reading (dBuV)	Correct Factor(dB/m)	Result (dBuV/m)	Limit (dBuV/m)	Margin (dB)	Remark
1	116.0000	42.24	-15.14	27.10	43.50	-16.40	QP
2	192.0000	41.98	-13.79	28.19	43.50	-15.31	QP
3	262.0000	42.35	-11.79	30.56	46.00	-15.44	QP
4	432.0000	39.53	-8.16	31.37	46.00	-14.63	QP
5	540.0000	45.94	-6.34	39.60	46.00	-6.40	QP
6	648.0000	34.07	-4.10	29.97	46.00	-16.03	QP

Above 1GHz

Standard:	FCC Part 15C			Test Distance:	3m		
Test item:	Radiated Emission			Power:	AC 120V/60Hz		
Model Number:	MZ505			Temp.(°C)/Hum.(%RH):	26(°C)/60%RH		
Mode:	Mode 2			Date:	07/13/2011		
Frequency:	2412MHz			Test By:	Gary Wu		
Frequency (MHz)	Reading (dBuV)	Correct Factor(dB/m)	Result (dBuV/m)	Limit (dBuV/m)	Margin (dB)	Remark	Ant.Polar. H / V
3989.000	41.24	5.29	46.53	74.00	-27.47	peak	H
4824.000	44.99	7.92	52.91	74.00	-21.09	peak	H
4824.000	42.98	7.92	50.90	54.00	-3.10	AVG	H
6299.000	39.00	12.03	51.03	74.00	-22.97	peak	H
3961.000	40.86	5.18	46.04	74.00	-27.96	peak	V
4824.000	43.13	7.92	51.05	74.00	-22.95	peak	V
6376.000	38.76	12.36	51.12	74.00	-22.88	peak	V

Standard:	FCC Part 15C			Test Distance:	3m		
Test item:	Radiated Emission			Power:	AC 120V/60Hz		
Model Number:	MZ505			Temp.(°C)/Hum.(%RH):	26(°C)/60%RH		
Mode:	Mode 2			Date:	07/13/2011		
Frequency:	2437MHz			Test By:	Gary Wu		
Frequency (MHz)	Reading (dBuV)	Correct Factor(dB/m)	Result (dBuV/m)	Limit (dBuV/m)	Margin (dB)	Remark	Ant.Polar. H / V
1595.000	46.34	-3.22	43.12	74.00	-30.88	peak	H
4255.000	40.78	6.11	46.89	74.00	-27.11	peak	H
4874.000	42.36	8.09	50.45	74.00	-23.55	peak	H
3730.000	41.11	4.29	45.40	74.00	-28.60	peak	V
4874.000	42.31	8.09	50.40	74.00	-23.60	peak	V
6495.000	38.23	12.87	51.10	74.00	-22.90	peak	V

Standard:	FCC Part 15C	Test Distance:	3m				
Test item:	Radiated Emission	Power:	AC 120V/60Hz				
Model Number:	MZ505	Temp.(°C)/Hum.(%RH):	26(°C)/60%RH				
Mode:	Mode 2	Date:	07/13/2011				
Frequency:	2462MHz	Test By:	Gary Wu				
Frequency (MHz)	Reading (dBuV)	Correct Factor(dB/m)	Result (dBuV/m)	Limit (dBuV/m)	Margin (dB)	Remark	Ant.Polar. H / V
1595.000	47.90	-3.22	44.68	74.00	-29.32	peak	H
3219.000	41.44	2.79	44.23	74.00	-29.77	peak	H
4924.000	42.03	8.25	50.28	74.00	-23.72	peak	H
3436.000	41.12	3.26	44.38	74.00	-29.62	peak	V
4924.000	42.18	8.25	50.43	74.00	-23.57	peak	V
6264.000	38.08	11.88	49.96	74.00	-24.04	peak	V

Standard:	FCC Part 15C			Test Distance:	3m		
Test item:	Radiated Emission			Power:	AC 120V/60Hz		
Model Number:	MZ505			Temp.(°C)/Hum.(%RH):	26(°C)/60%RH		
Mode:	Mode 3			Date:	07/13/2011		
Frequency:	2412MHz			Test By:	Gary Wu		
Frequency (MHz)	Reading (dBuV)	Correct Factor(dB/m)	Result (dBuV/m)	Limit (dBuV/m)	Margin (dB)	Remark	Ant.Polar. H / V
2806.000	40.69	1.50	42.19	74.00	-31.81	peak	H
4824.000	41.52	7.92	49.44	74.00	-24.56	peak	H
6215.000	38.45	11.68	50.13	74.00	-23.87	peak	H
2834.000	40.75	1.61	42.36	74.00	-31.64	peak	V
4262.000	39.98	6.13	46.11	74.00	-27.89	peak	V
5620.000	38.53	10.17	48.70	74.00	-25.30	peak	V

Standard:	FCC Part 15C			Test Distance:	3m		
Test item:	Radiated Emission			Power:	AC 120V/60Hz		
Model Number:	MZ505			Temp.(°C)/Hum.(%RH):	26(°C)/60%RH		
Mode:	Mode 3			Date:	07/13/2011		
Frequency:	2437MHz			Test By:	Gary Wu		
Frequency (MHz)	Reading (dBuV)	Correct Factor(dB/m)	Result (dBuV/m)	Limit (dBuV/m)	Margin (dB)	Remark	Ant.Polar. H / V
3261.000	42.35	2.88	45.23	74.00	-28.77	peak	H
5214.000	38.62	9.13	47.75	74.00	-26.25	peak	H
6278.000	37.75	11.94	49.69	74.00	-24.31	peak	H
2771.000	40.62	1.35	41.97	74.00	-32.03	peak	V
4164.000	40.14	5.83	45.97	74.00	-28.03	peak	V
5886.000	38.42	10.58	49.00	74.00	-25.00	peak	V

Standard:	FCC Part 15C	Test Distance:	3m
Test item:	Radiated Emission	Power:	AC 120V/60Hz
Model Number:	MZ505	Temp.(°C)/Hum.(%RH):	26(°C)/60%RH
Mode:	Mode 3	Date:	07/13/2011
Frequency:	2462MHz	Test By:	Gary Wu

Frequency (MHz)	Reading (dBuV)	Correct Factor(dB/m)	Result (dBuV/m)	Limit (dBuV/m)	Margin (dB)	Remark	Ant.Polar. H / V
2561.000	40.96	0.49	41.45	74.00	-32.55	peak	H
4924.000	40.70	8.25	48.95	74.00	-25.05	peak	H
6222.000	38.56	11.71	50.27	74.00	-23.73	peak	H
1595.000	52.00	-3.22	48.78	74.00	-25.22	peak	V
3835.000	40.02	4.70	44.72	74.00	-29.28	peak	V
6054.000	38.50	10.99	49.49	74.00	-24.51	peak	V

Standard:	FCC Part 15C			Test Distance:	3m		
Test item:	Radiated Emission			Power:	AC 120V/60Hz		
Model Number:	MZ505			Temp.(°C)/Hum.(%RH):	26(°C)/60%RH		
Mode:	Mode 4			Date:	07/13/2011		
Frequency:	2412MHz			Test By:	Gary Wu		
Frequency (MHz)	Reading (dBuV)	Correct Factor(dB/m)	Result (dBuV/m)	Limit (dBuV/m)	Margin (dB)	Remark	Ant.Polar. H / V
1595.000	47.20	-3.22	43.98	74.00	-30.02	peak	H
4824.000	40.87	7.92	48.79	74.00	-25.21	peak	H
6831.000	35.61	13.90	49.51	74.00	-24.49	peak	H
3058.000	39.05	2.42	41.47	74.00	-32.53	peak	V
4824.000	38.86	7.92	46.78	74.00	-27.22	peak	V
6936.000	35.66	14.21	49.87	74.00	-24.13	peak	V

Standard:	FCC Part 15C			Test Distance:	3m		
Test item:	Radiated Emission			Power:	AC 120V/60Hz		
Model Number:	MZ505			Temp.(°C)/Hum.(%RH):	26(°C)/60%RH		
Mode:	Mode 4			Date:	07/13/2011		
Frequency:	2437MHz			Test By:	Gary Wu		
Frequency (MHz)	Reading (dBuV)	Correct Factor(dB/m)	Result (dBuV/m)	Limit (dBuV/m)	Margin (dB)	Remark	Ant.Polar. H / V
2414.000	40.96	-0.12	40.84	74.00	-33.16	peak	H
4874.000	40.38	8.09	48.47	74.00	-25.53	peak	H
7076.000	35.82	14.61	50.43	74.00	-23.57	peak	H
1525.000	52.36	-3.47	48.89	74.00	-25.11	peak	V
4874.000	39.87	8.09	47.96	74.00	-26.04	peak	V
6054.000	36.74	10.99	47.73	74.00	-26.27	peak	V

Standard:	FCC Part 15C			Test Distance:	3m		
Test item:	Radiated Emission			Power:	AC 120V/60Hz		
Model Number:	MZ505			Temp.(°C)/Hum.(%RH):	26(°C)/60%RH		
Mode:	Mode 4			Date:	07/13/2011		
Frequency:	2462MHz			Test By:	Gary Wu		
Frequency (MHz)	Reading (dBuV)	Correct Factor(dB/m)	Result (dBuV/m)	Limit (dBuV/m)	Margin (dB)	Remark	Ant.Polar. H / V
2435.000	41.22	-0.03	41.19	74.00	-32.81	peak	H
5557.000	35.11	10.08	45.19	74.00	-28.81	peak	H
6894.000	35.47	14.09	49.56	74.00	-24.44	peak	H
3114.000	37.53	2.56	40.09	74.00	-33.91	peak	V
5410.000	35.79	9.72	45.51	74.00	-28.49	peak	V
7174.000	34.48	14.87	49.35	74.00	-24.65	peak	V

Standard:	FCC Part 15C			Test Distance:	3m			
Test item:	Radiated Emission			Power:	AC 120V/60Hz			
Model Number:	MZ505			Temp.(°C)/Hum.(%RH):	26(°C)/60%RH			
Mode:	Mode 5			Date:	07/13/2011			
Modulation:	draft 802.11n Standard-20MHz			Test By:	Gary Wu			
Frequency:	2437MHz							
Frequency (MHz)	Reading (dBuV)	Correct Factor(dB/m)	Result (dBuV/m)	Peak Limit (dBuV/m)	AVG. Limit (dBuV/m)	Margin (dB)	Remark	Ant.Polar. H / V
5130.000	37.03	8.88	45.91	74.00	54.00	-28.09	peak	H
6404.000	35.63	12.47	48.10	74.00	54.00	-25.90	peak	H
7552.000	35.33	15.82	51.15	74.00	54.00	-22.85	peak	H
1602.000	41.71	-3.20	38.51	74.00	54.00	-35.49	peak	V
4164.000	36.94	5.83	42.77	74.00	54.00	-31.23	peak	V
7335.000	34.82	15.29	50.11	74.00	54.00	-23.89	peak	V

6 Maximum Conducted Output Power Measurement

6.1. Limit

For systems using digital modulation in the 2400-2483.5MHz, the limit for peak output power is 30dBm.

6.2. Test Setup

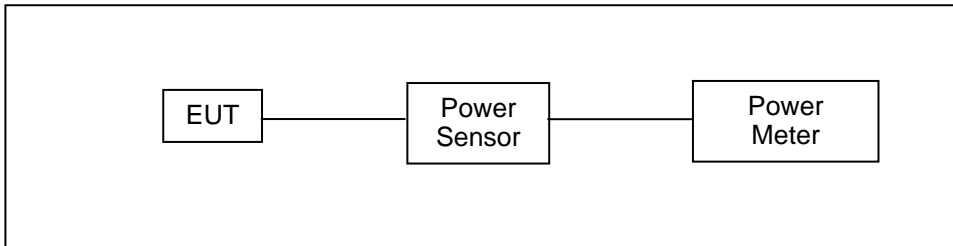

6.3. Test Instruments

Equipment	Manufacturer	Model Number	Serial Number	Cal. Date	Remark
Single Channel PK Power Sensor	Agilent	N1911A	MY45101619	07/19/2010	(1)
Wideband Power Meter	Agilent	N1921A	MY45241957	07/19/2010	(1)
Test Site	ATL	TE02	TE02	N.C.R.	-----

Remark: (1) Calibration period 1 year. (2) Calibration period 2 years.

NOTE: N.C.R. = No Calibration Request.

6.4. Test Procedure

The tests below are run with the EUT's transmitter set at high power in TX mode. The EUT is needed to force selection of output power level and channel number. While testing, EUT was set to transmit continuously. Remove the Subjective device's antenna and connect the RF output port to power sensor. The maximum peak output power shall not exceed 1 watt.

Use a direct connection between the antenna port of transmitter and the power sensor, for prevent the power sensor input attenuation 40-50 dB. Set the RBW Bandwidth of the emission or use a channel power meter mode.

For antennas with gains of 6 dBi or less, maximum allowed transmitter output is 1 watt (+30 dBm). For antennas with gains greater than 6 dBi, transmitter output level must be decreased by an amount equal to $(\text{GAIN} - 6)/3$ dBm.

The antenna port of the EUT was connected to the input of a power sensor. Power was read directly and cable loss correction was added to the reading to obtain power at the EUT antenna terminals.

6.5. Test Result

Model Number	MZ505					
Test Item	Maximum Conducted Output Power					
Test Mode	Mode 2: IEEE 802.11b Link Mode					
Date of Test	07/04/2011			Test Site	TE02	
Frequency (MHz)	Data Rate	Average Power		Peak Power		Limit (dBm)
		(dBm)	(W)	(dBm)	(W)	
2412	1 M	14.08	0.026	17.42	0.055	< 30
2437		13.77	0.024	17.04	0.051	< 30
2462		13.88	0.024	17.03	0.050	< 30
2412	11 M	12.94	0.020	17.07	0.051	< 30
2437		13.08	0.020	17.35	0.054	< 30
2462		13.07	0.020	17.19	0.052	< 30

Model Number	MZ505					
Test Item	Maximum Conducted Output Power					
Test Mode	Mode 3: IEEE 802.11g Link Mode					
Date of Test	07/04/2011			Test Site	TE02	
Frequency (MHz)	Data Rate	Average Power		Peak Power		Limit (dBm)
		(dBm)	(W)	(dBm)	(W)	
2412	6 M	13.22	0.021	22.58	0.181	< 30
2437		13.37	0.022	22.40	0.174	< 30
2462		13.46	0.022	22.87	0.194	< 30
2412	54 M	9.80	0.010	22.50	0.178	< 30
2437		10.28	0.011	22.86	0.193	< 30
2462		10.60	0.011	22.94	0.197	< 30

Model Number	MZ505					
Test Item	Maximum Conducted Output Power					
Test Mode	Mode 4: draft 802.11n Standard-20MHz Link Mode					
Date of Test	07/04/2011			Test Site	TE02	
Frequency (MHz)	Data Rate	Average Power		Peak Power		Limit (dBm)
		(dBm)	(W)	(dBm)	(W)	
2412	6.5 M	10.40	0.011	21.74	0.149	< 30
2437		10.65	0.012	22.02	0.159	< 30
2462		10.97	0.013	22.15	0.164	< 30
2412	65 M	6.73	0.005	21.27	0.134	< 30
2437		7.33	0.005	21.61	0.145	< 30
2462		7.90	0.006	21.53	0.142	< 30

7 6dB RF Bandwidth Measurement

7.1. Limit

Systems using digital modulation techniques may operate in the 2400–2483.5 MHz bands. The minimum 6 dB band-width shall be at least 500 kHz.

7.2. Test Setup

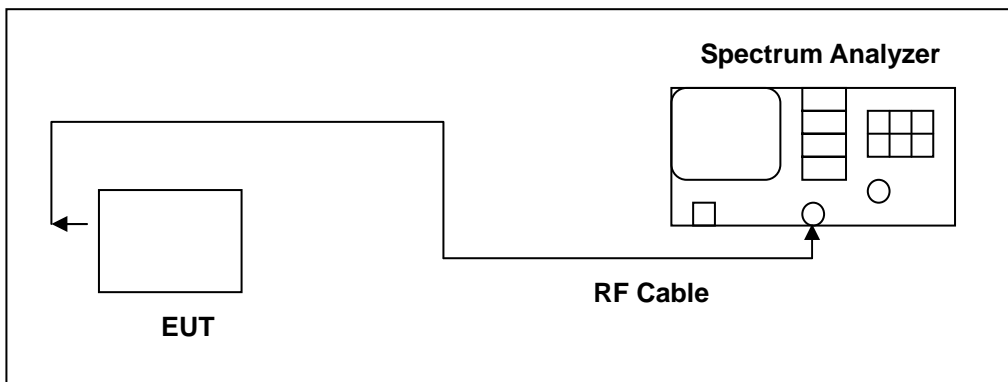

7.3. Test Instruments

Equipment	Manufacturer	Model Number	Serial Number	Cal. Date	Remark
Spectrum Analyzer	Agilent	E4445A	MY45300744	12/28/2010	(2)
Test Site	ATL	TE02	TE02	N.C.R.	-----

Remark: (1) Calibration period 1 year. (2) Calibration period 2 years.

NOTE: N.C.R. = No Calibration Request.

7.4. Test Procedure

The EUT was setup to ANSI C63.4, 2009; tested to DTS test procedure of Oct 2002 KDB558074 for compliance to FCC 47CFR 15.247 requirements.

The antenna port of the EUT was connected to the input of a spectrum analyzer. Analyzer RES BW was set to 100 kHz. For each RF output channel investigated, the spectrum analyzer center frequency was set to the channel carrier. A peak output reading was taken, a DISPLAY line was drawn 6 dB lower than peak level. The 6 dB bandwidth was determined from where the channel output spectrum intersected the display line.

The test was performed at 3 channels (Channel 1, 6, 11)

7.5. Test Result

Model Number	MZ505		
Test Item	6dB RF Bandwidth		
Test Mode	Mode 2: IEEE 802.11b Link Mode		
Date of Test	07/06/2011	Test Site	TE02
	Frequency (MHz)	Measurement (kHz)	Limit (kHz)
	2412	8670	> 500
	2437	8170	> 500
	2462	8580	> 500

Model Number	MZ505		
Test Item	6dB RF Bandwidth		
Test Mode	Mode 3: IEEE 802.11g Link Mode		
Date of Test	07/06/2011	Test Site	TE06
	Frequency (MHz)	Measurement (kHz)	Limit (kHz)
	2412	15250	> 500
	2437	15420	> 500
	2462	15330	> 500

Model Number	MZ505		
Test Item	6dB RF Bandwidth		
Test Mode	Mode 4: draft 802.11n Standard-20MHz Link Mode		
Date of Test	07/06/2011	Test Site	TE02
	Frequency (MHz)	Measurement (kHz)	Limit (kHz)
	2412	17250	> 500
	2437	16080	> 500
	2462	15750	> 500

7.6. Test Graphs

Mode 2: IEEE 802.11b Link Mode	
2412	<p>Copyright 2000-2005 Agilent Technologies</p>
2437	<p>Copyright 2000-2005 Agilent Technologies</p>
2462	<p>Copyright 2000-2005 Agilent Technologies</p>

Mode 3: IEEE 802.11g Link Mode

2412

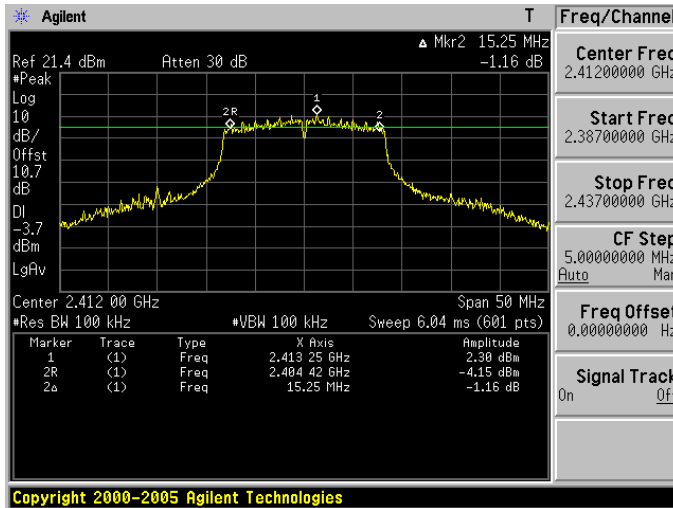

2437

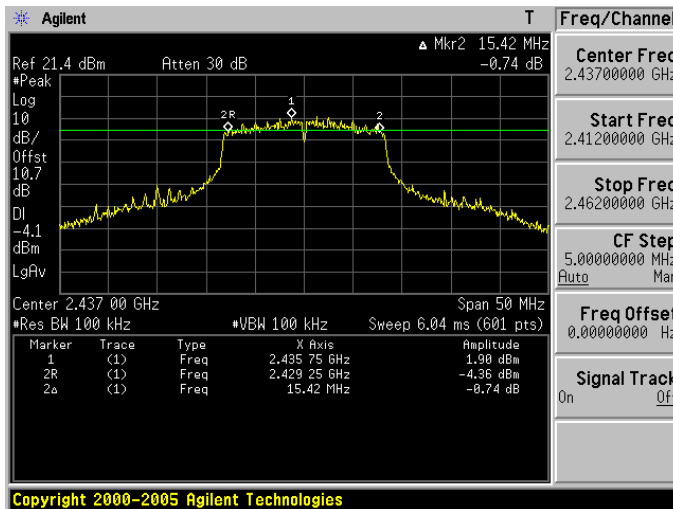

2462

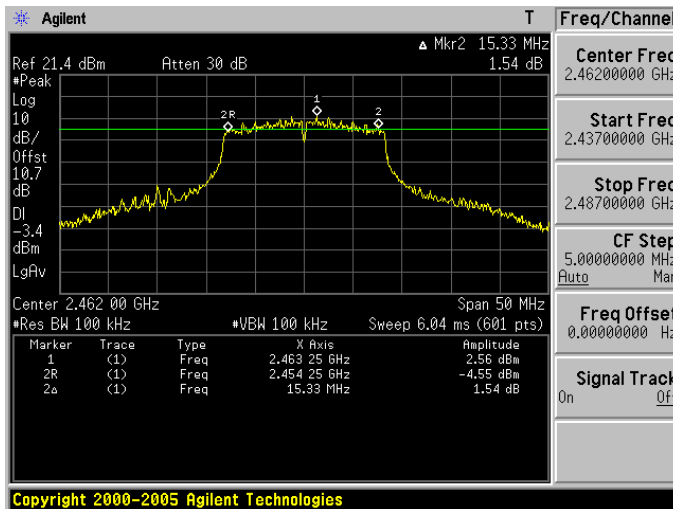

Mode 4: draft 802.11n Standard-20MHz Link Mode

2412

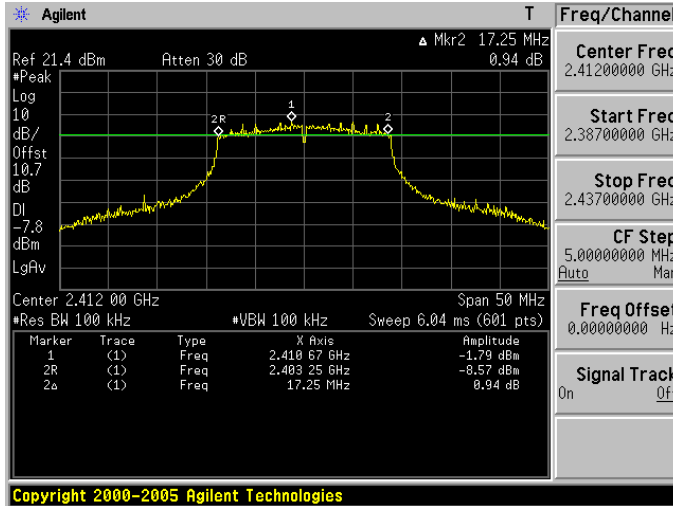

2437

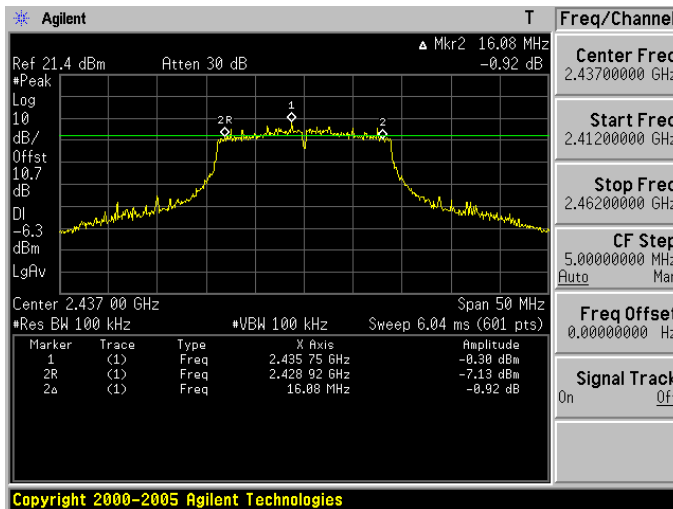

2462

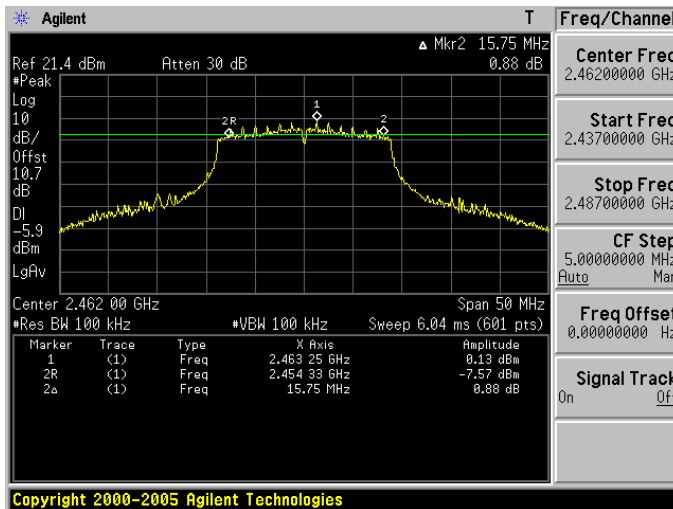

8 Maximum Power Density Measurement

8.1. Limit

For digitally modulated systems, the power spectral density conducted from the intentional radiator to the antenna shall not be greater than 8 dBm in any 3 kHz band during any time interval of continuous transmission.

8.2. Test Setup

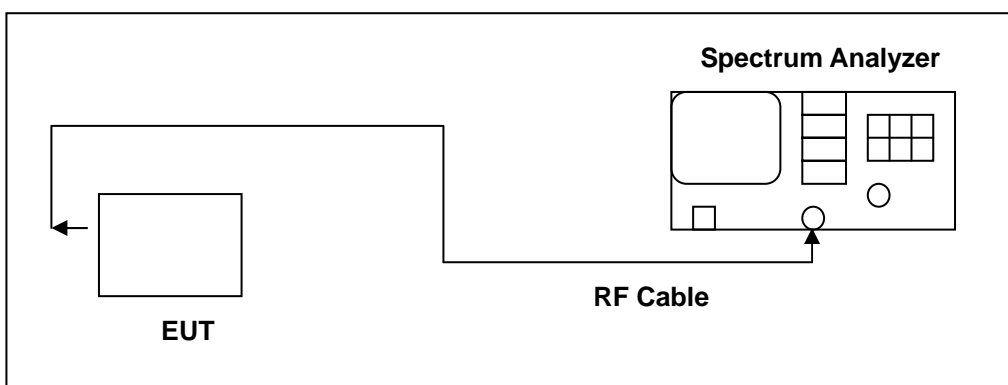

8.3. Test Instruments

Equipment	Manufacturer	Model Number	Serial Number	Cal. Date	Remark
Spectrum Analyzer	Agilent	E4445A	MY45300744	12/28/2010	(2)
Test Site	ATL	TE02	TE02	N.C.R.	-----

Remark: (1) Calibration period 1 year. (2) Calibration period 2 years.

NOTE: N.C.R. = No Calibration Request.

8.4. Test Procedure

The EUT was setup to ANSI C63.4, 2009; tested to DTS test procedure of Oct 2002 KDB558074 for compliance to FCC 47CFR 15.247 requirements.

The spectrum analyzer RES BW was set to 3 kHz. The START and STOP frequencies were set to the band edges of the maximum output pass band. If there is no clear maximum amplitude in any given portion of the band, it may be necessary to make measurements at a number of bands defined by several START and STOP frequency pairs. The specification calls for a 1 second interval at each 3 kHz bandwidth; total SWEEP TIME is calculated as follows:

$$\text{SWEEP TIME (SEC)} = (\text{Fstop, kHz} - \text{Fstart, kHz}) / 3 \text{ kHz}$$

Antenna output of the EUT was coupled directly to spectrum analyzer; if an external attenuator and/or cable was used, these losses are compensated for with the analyzer OFFSET function.

8.5. Test Result

Model Number	MZ505		
Test Item	Maximum Power Density		
Test Mode	Mode 2: IEEE 802.11b Link Mode		
Date of Test	07/06/2011	Test Site	TE02
	Frequency (MHz)	Measurement (dBm)	Limit (dBm)
	2412	-8.07	< 8
	2437	-8.60	< 8
	2462	-8.37	< 8

Model Number	MZ505		
Test Item	Maximum Power Density		
Test Mode	Mode 3: IEEE 802.11g Link Mode		
Date of Test	07/06/2011	Test Site	TE02
	Frequency (MHz)	Measurement (dBm)	Limit (dBm)
	2412	-12.68	< 8
	2437	-12.70	< 8
	2462	-11.73	< 8

Model Number	MZ505		
Test Item	Maximum Power Density		
Test Mode	Mode 4: draft 802.11n Standard-20MHz Link Mode		
Date of Test	07/06/2011	Test Site	TE02
	Frequency (MHz)	Measurement (dBm)	Limit (dBm)
	2412	-14.29	< 8
	2437	-16.73	< 8
	2462	-13.76	< 8

8.6. Test Graphs

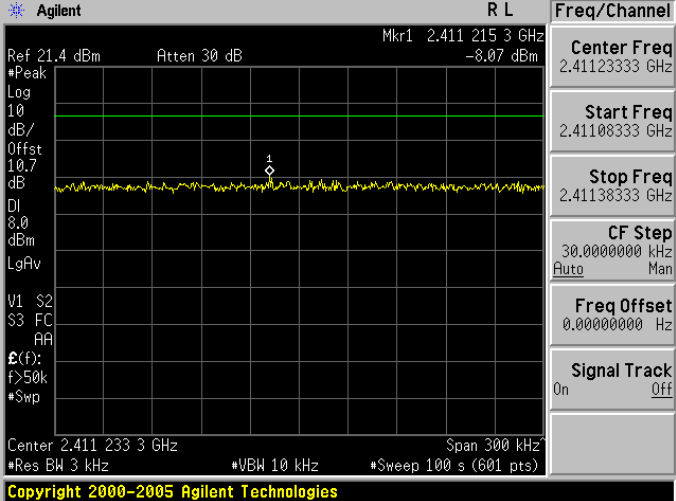
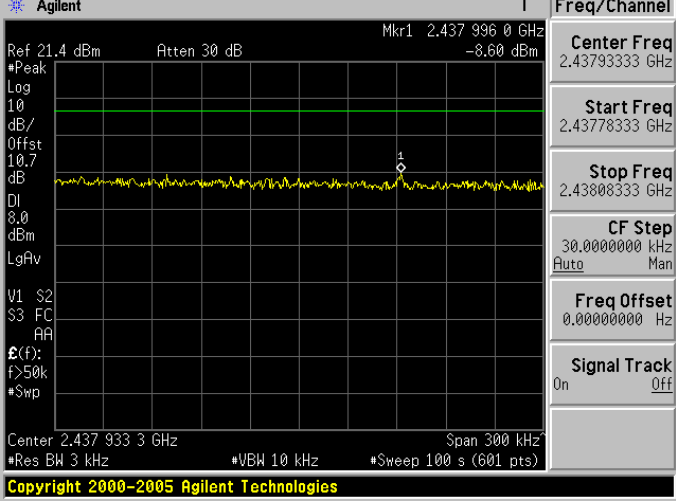
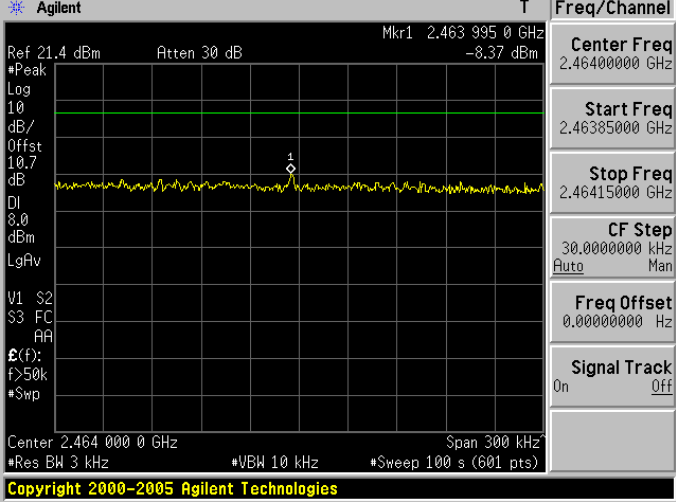
Mode 2: IEEE 802.11b Link Mode	
2412	 <p>Agilent R L Freq/Channel Ref 21.4 dBm Atten 30 dB Mkr1 2.411 215 3 GHz -8.07 dBm #Peak Log 10 dB/ Offst 10.7 dB DI 8.0 dBm LgAv V1 S2 S3 FC AA E(f): f>50k #Swp Center 2.411 233 3 GHz Span 300 kHz #Res BW 3 kHz #VBW 10 kHz #Sweep 100 s (601 pts) Copyright 2000-2005 Agilent Technologies</p> <p>Freq/Channel Center Freq 2.41123333 GHz Start Freq 2.41100333 GHz Stop Freq 2.41138333 GHz CF Step 30.0000000 kHz Auto Man Freq Offset 0.00000000 Hz Signal Track On Off</p>
2437	 <p>Agilent T Freq/Channel Ref 21.4 dBm Atten 30 dB Mkr1 2.437 996 0 GHz -8.60 dBm #Peak Log 10 dB/ Offst 10.7 dB DI 8.0 dBm LgAv V1 S2 S3 FC AA E(f): f>50k #Swp Center 2.437 933 3 GHz Span 300 kHz #Res BW 3 kHz #VBW 10 kHz #Sweep 100 s (601 pts) Copyright 2000-2005 Agilent Technologies</p> <p>Freq/Channel Center Freq 2.43793333 GHz Start Freq 2.43778333 GHz Stop Freq 2.43808333 GHz CF Step 30.0000000 kHz Auto Man Freq Offset 0.00000000 Hz Signal Track On Off</p>
2462	 <p>Agilent T Freq/Channel Ref 21.4 dBm Atten 30 dB Mkr1 2.463 995 0 GHz -8.37 dBm #Peak Log 10 dB/ Offst 10.7 dB DI 8.0 dBm LgAv V1 S2 S3 FC AA E(f): f>50k #Swp Center 2.464 000 0 GHz Span 300 kHz #Res BW 3 kHz #VBW 10 kHz #Sweep 100 s (601 pts) Copyright 2000-2005 Agilent Technologies</p> <p>Freq/Channel Center Freq 2.46400000 GHz Start Freq 2.46385000 GHz Stop Freq 2.46415000 GHz CF Step 30.0000000 kHz Auto Man Freq Offset 0.00000000 Hz Signal Track On Off</p>

Mode 3: IEEE 802.11g Link Mode

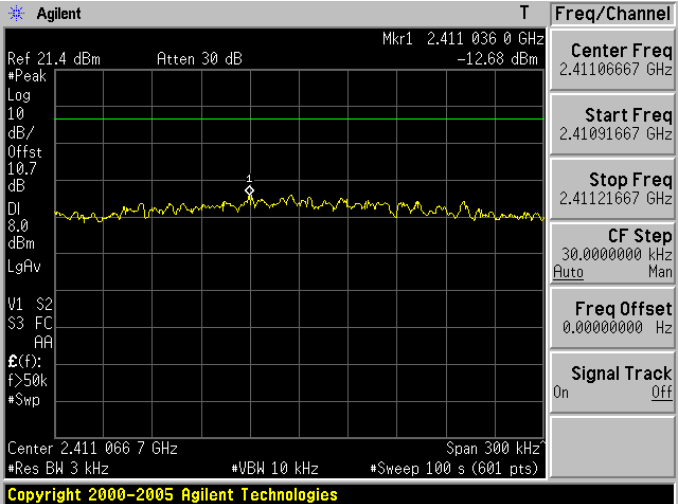
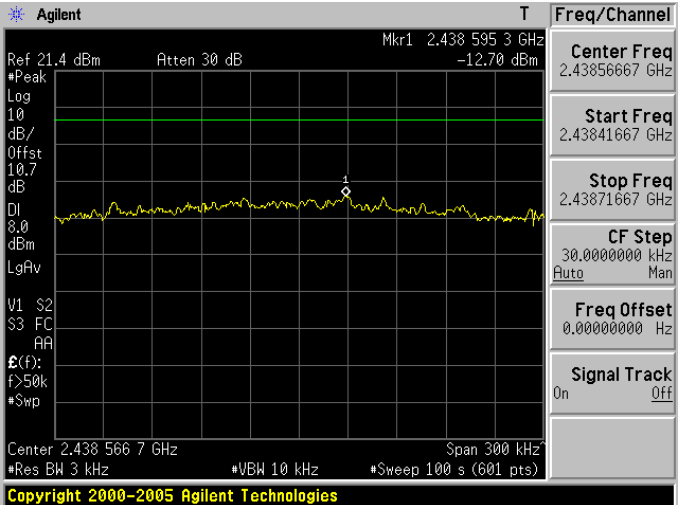
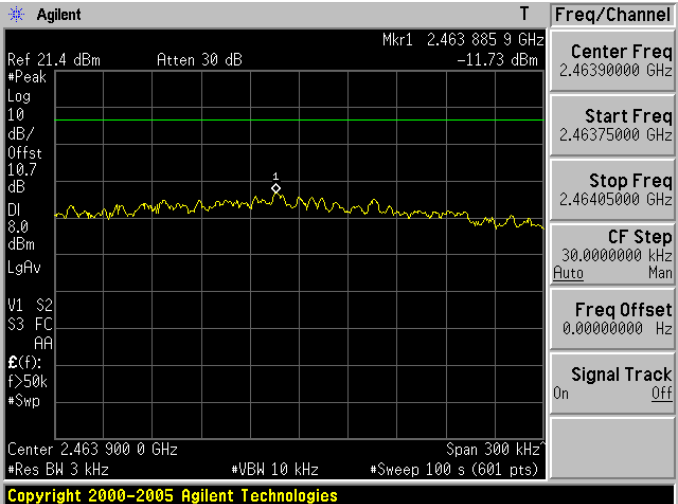
<p>2412</p>	 <p>Agilent T Freq/Channel</p> <p>Ref 21.4 dBm Atten 30 dB Mkr1 2.411 036 0 GHz -12.68 dBm</p> <p>*Peak</p> <p>Log</p> <p>10</p> <p>dB/</p> <p>Offst</p> <p>10.7</p> <p>dB</p> <p>DI</p> <p>8.0</p> <p>dBm</p> <p>LgAv</p> <p>V1 S2</p> <p>S3 FC</p> <p>AA</p> <p>E(f):</p> <p>f>50k</p> <p>*Swp</p> <p>Center 2.411 066 7 GHz Span 300 kHz</p> <p>*Res BW 3 kHz *VBW 10 kHz *Sweep 100 s (601 pts)</p> <p>Copyright 2000-2005 Agilent Technologies</p> <p>Center Freq 2.41106667 GHz</p> <p>Start Freq 2.41091667 GHz</p> <p>Stop Freq 2.41121667 GHz</p> <p>CF Step 30.0000000 kHz Auto Man</p> <p>Freq Offset 0.00000000 Hz</p> <p>Signal Track On Off</p>
<p>2437</p>	 <p>Agilent T Freq/Channel</p> <p>Ref 21.4 dBm Atten 30 dB Mkr1 2.438 595 3 GHz -12.70 dBm</p> <p>*Peak</p> <p>Log</p> <p>10</p> <p>dB/</p> <p>Offst</p> <p>10.7</p> <p>dB</p> <p>DI</p> <p>8.0</p> <p>dBm</p> <p>LgAv</p> <p>V1 S2</p> <p>S3 FC</p> <p>AA</p> <p>E(f):</p> <p>f>50k</p> <p>*Swp</p> <p>Center 2.438 566 7 GHz Span 300 kHz</p> <p>*Res BW 3 kHz *VBW 10 kHz *Sweep 100 s (601 pts)</p> <p>Copyright 2000-2005 Agilent Technologies</p> <p>Center Freq 2.43856667 GHz</p> <p>Start Freq 2.43841667 GHz</p> <p>Stop Freq 2.43871667 GHz</p> <p>CF Step 30.0000000 kHz Auto Man</p> <p>Freq Offset 0.00000000 Hz</p> <p>Signal Track On Off</p>
<p>2462</p>	 <p>Agilent T Freq/Channel</p> <p>Ref 21.4 dBm Atten 30 dB Mkr1 2.463 885 9 GHz -11.73 dBm</p> <p>*Peak</p> <p>Log</p> <p>10</p> <p>dB/</p> <p>Offst</p> <p>10.7</p> <p>dB</p> <p>DI</p> <p>8.0</p> <p>dBm</p> <p>LgAv</p> <p>V1 S2</p> <p>S3 FC</p> <p>AA</p> <p>E(f):</p> <p>f>50k</p> <p>*Swp</p> <p>Center 2.463 900 0 GHz Span 300 kHz</p> <p>*Res BW 3 kHz *VBW 10 kHz *Sweep 100 s (601 pts)</p> <p>Copyright 2000-2005 Agilent Technologies</p> <p>Center Freq 2.46390000 GHz</p> <p>Start Freq 2.46375000 GHz</p> <p>Stop Freq 2.46405000 GHz</p> <p>CF Step 30.0000000 kHz Auto Man</p> <p>Freq Offset 0.00000000 Hz</p> <p>Signal Track On Off</p>

Mode 4: draft 802.11n Standard-20MHz Link Mode

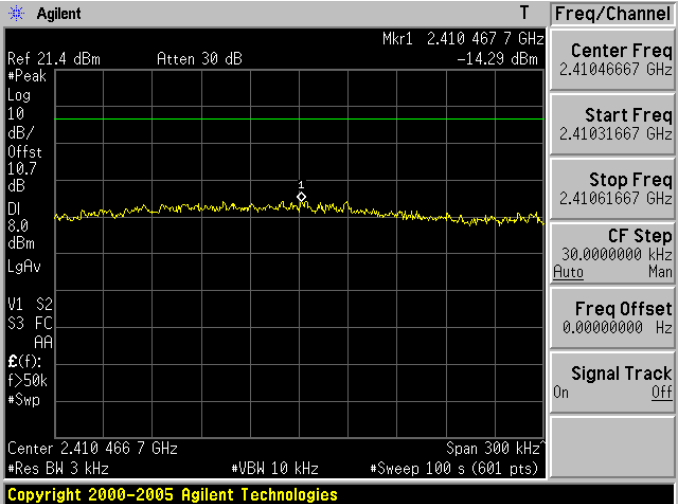
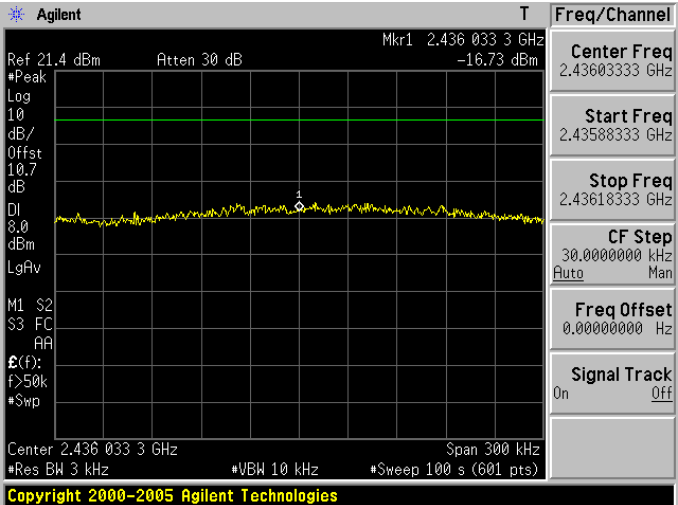
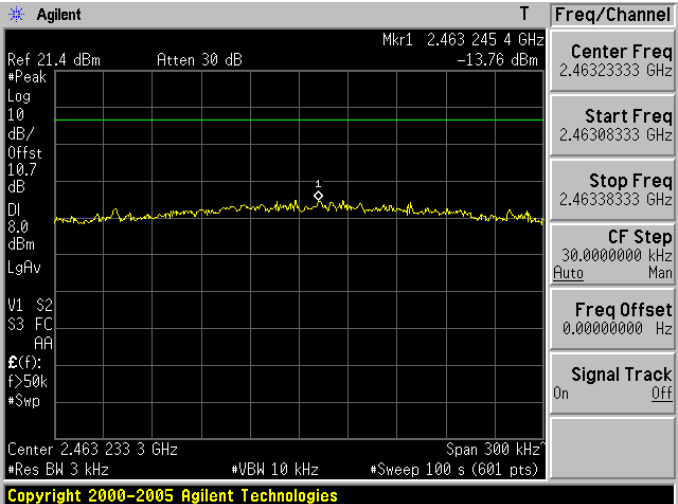
<p>2412</p>	 <p>Copyright 2000-2005 Agilent Technologies</p>
<p>2437</p>	 <p>Copyright 2000-2005 Agilent Technologies</p>
<p>2462</p>	 <p>Copyright 2000-2005 Agilent Technologies</p>

9 Out of Band Conducted Emissions Measurement

9.1. Limit

In any 100 kHz bandwidth outside the frequency band in which the spread spectrum or digitally modulated intentional radiator is operating, the radio frequency power that is produced by the intentional radiator shall be at least 20 dB below that in the 100 kHz bandwidth within the band that contains the highest level of the desired power

9.2. Test Setup

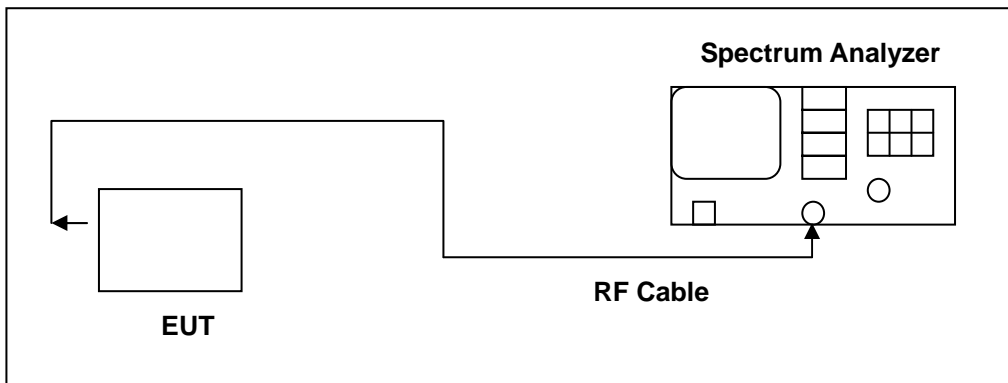

9.3. Test Instruments

Equipment	Manufacturer	Model Number	Serial Number	Cal. Date	Remark
Spectrum Analyzer	Agilent	E4445A	MY45300744	12/28/2010	(2)
Spectrum Analyzer	Agilent	E4408B	MY45107753	07/07/2011	(1)
Test Site	ATL	TE02	TE02	N.C.R.	-----

Remark: (1) Calibration period 1 year. (2) Calibration period 2 years.

NOTE: N.C.R. = No Calibration Request.

9.4. Test Procedure

In any 100 kHz bandwidth outside the EUT pass band, the RF power produced by the modulation products of the spreading sequence, the information sequence, and the carrier frequency shall be at least 20 dB below that of the maximum in-band 100 kHz emission, antenna output of the EUT was coupled directly to spectrum analyzer; if an external attenuator and/or cable was used, these losses are compensated for with the analyzer OFFSET function.

All other types of emissions from the EUT shall meet the general limits for radiated frequencies outside the pass band. The test was performed at 3 channels (Channel 1, 6, 11)

9.5. Test Graphs

Mode 2: IEEE 802.11b Link Mode	
2412	<p>Agilent 16:08:22 Jul 6, 2011 R T Ref 20.7 dBm Atten 30 dB Mkr1 2.41 GHz 5.407 dBm Peak Log 10 dB/ Offst 0.7 dB DI -14.6 dBm V1 S2 S3 FC AA Center 13.27 GHz Span 26.47 GHz #Res BW 100 kHz #VBW 100 kHz Sweep 3.41 s (401 pts)</p> <p>Freq/Channel Center Freq 13.2650000 GHz Start Freq 30.0000000 MHz Stop Freq 26.5000000 GHz CF Step 2.64700000 GHz Auto Man Freq Offset 0.00000000 Hz Signal Track On Off</p>
2437	<p>Agilent 16:08:59 Jul 6, 2011 R T Ref 20.7 dBm Atten 30 dB Mkr1 2.44 GHz 8.3 dBm Peak Log 10 dB/ Offst 0.7 dB DI -11.7 dBm V1 S2 S3 FC AA Center 13.27 GHz Span 26.47 GHz #Res BW 100 kHz #VBW 100 kHz Sweep 3.41 s (401 pts)</p> <p>Freq/Channel Center Freq 13.2650000 GHz Start Freq 30.0000000 MHz Stop Freq 26.5000000 GHz CF Step 2.64700000 GHz Auto Man Freq Offset 0.00000000 Hz Signal Track On Off</p>
2462	<p>Agilent 16:08:59 Jul 6, 2011 R T Ref 20.7 dBm Atten 30 dB Mkr1 2.44 GHz 8.3 dBm Peak Log 10 dB/ Offst 0.7 dB DI -11.7 dBm V1 S2 S3 FC AA Center 13.27 GHz Span 26.47 GHz #Res BW 100 kHz #VBW 100 kHz Sweep 3.41 s (401 pts)</p> <p>Freq/Channel Center Freq 13.2650000 GHz Start Freq 30.0000000 MHz Stop Freq 26.5000000 GHz CF Step 2.64700000 GHz Auto Man Freq Offset 0.00000000 Hz Signal Track On Off</p>

Mode 3: IEEE 802.11g Link Mode

2412	<p>Agilent 16:12:00 Jul 6, 2011 R T</p> <p>Ref 20.7 dBm Atten 30 dB Mkr1 2.41 GHz 1.369 dBm</p> <p>Peak Log 10 dB/ Offst 0.7 dB DI -18.6 dBm</p> <p>V1 S2 S3 FC AA</p> <p>Center 13.27 GHz Span 26.47 GHz #Res BW 100 kHz #VBW 100 kHz Sweep 3.41 s (401 pts)</p> <p>Freq/Channel: Center Freq 13.2650000 GHz, Start Freq 30.0000000 MHz, Stop Freq 26.5000000 GHz, CF Step 2.64700000 GHz, Freq Offset 0.0000000 Hz, Signal Track Off</p>
2437	<p>Agilent 16:12:40 Jul 6, 2011 R T</p> <p>Ref 20.7 dBm Atten 30 dB Mkr1 2.44 GHz 3.177 dBm</p> <p>Peak Log 10 dB/ Offst 0.7 dB DI -16.8 dBm</p> <p>V1 S2 S3 FC AA</p> <p>Center 13.27 GHz Span 26.47 GHz #Res BW 100 kHz #VBW 100 kHz Sweep 3.41 s (401 pts)</p> <p>Freq/Channel: Center Freq 13.2650000 GHz, Start Freq 30.0000000 MHz, Stop Freq 26.5000000 GHz, CF Step 2.64700000 GHz, Freq Offset 0.0000000 Hz, Signal Track Off</p>
2462	<p>Agilent 16:13:42 Jul 6, 2011 R T</p> <p>Ref 20.7 dBm Atten 30 dB Mkr1 2.46 GHz 2.081 dBm</p> <p>Peak Log 10 dB/ Offst 0.7 dB DI -17.9 dBm</p> <p>V1 S2 S3 FC AA</p> <p>Center 13.27 GHz Span 26.47 GHz #Res BW 100 kHz #VBW 100 kHz Sweep 3.41 s (401 pts)</p> <p>Freq/Channel: Center Freq 13.2650000 GHz, Start Freq 30.0000000 MHz, Stop Freq 26.5000000 GHz, CF Step 2.64700000 GHz, Freq Offset 0.0000000 Hz, Signal Track Off</p>

Mode 4: draft 802.11n Standard-20MHz Link Mode

<p>2412</p>	<p>Agilent 16:15:12 Jul 6, 2011 R T</p> <p>Ref 20.7 dBm Atten 30 dB Mkr1 2.41 GHz 1.539 dBm</p> <p>Peak Log 10 dB/ Offst 0.7 dB DI -18.5 dBm</p> <p>V1 S2 S3 FC AA</p> <p>Center 13.27 GHz Span 26.47 GHz #Res BW 100 kHz #VBW 100 kHz Sweep 3.41 s (401 pts)</p> <p>Freq/Channel Center Freq 13.2650000 GHz Start Freq 30.0000000 MHz Stop Freq 26.5000000 GHz CF Step 2.64700000 GHz Auto Man Freq Offset 0.0000000 Hz Signal Track On Off</p>
<p>2437</p>	<p>Agilent 16:16:37 Jul 6, 2011 R T</p> <p>Ref 20.7 dBm Atten 30 dB Mkr1 2.44 GHz 0.627 dBm</p> <p>Peak Log 10 dB/ Offst 0.7 dB DI -19.4 dBm</p> <p>V1 S2 S3 FC AA</p> <p>Center 13.27 GHz Span 26.47 GHz #Res BW 100 kHz #VBW 100 kHz Sweep 3.41 s (401 pts)</p> <p>Freq/Channel Center Freq 13.2650000 GHz Start Freq 30.0000000 MHz Stop Freq 26.5000000 GHz CF Step 2.64700000 GHz Auto Man Freq Offset 0.0000000 Hz Signal Track On Off</p>
<p>2462</p>	<p>Agilent 16:18:18 Jul 6, 2011 R T</p> <p>Ref 20.7 dBm Atten 30 dB Mkr1 2.46 GHz -1.899 dBm</p> <p>Peak Log 10 dB/ Offst 0.7 dB DI -21.9 dBm</p> <p>V1 S2 S3 FC AA</p> <p>Center 13.27 GHz Span 26.47 GHz #Res BW 100 kHz #VBW 100 kHz Sweep 3.41 s (401 pts)</p> <p>Freq/Channel Center Freq 13.2650000 GHz Start Freq 30.0000000 MHz Stop Freq 26.5000000 GHz CF Step 2.64700000 GHz Auto Man Freq Offset 0.0000000 Hz Signal Track On Off</p>

10 Band Edges Measurement

10.1.Limit

In any 100 kHz bandwidth outside the intentional radiation frequency band, the radio frequency power shall be at least 20 dB below the highest level of the radiated power. In addition, radiated emissions which fall in the restricted bands must also comply with the radiated emission limits.

10.2.Test Setup

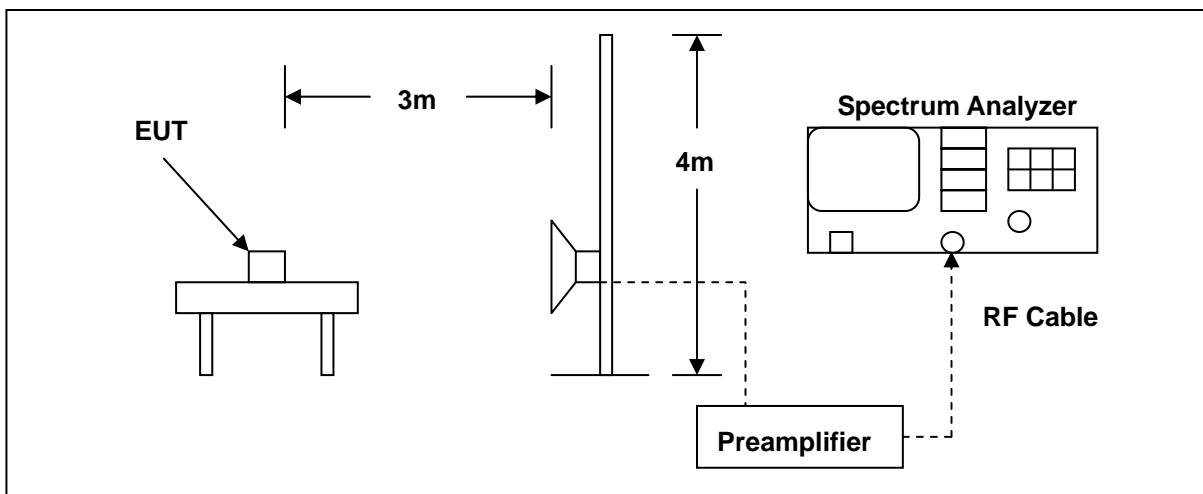

10.3.Test Instruments

Equipment	Manufacturer	Model Number	Serial Number	Cal. Date	Remark
Spectrum Analyzer	Agilent	E4408B	MY45107753	07/07/2011	(1)
Pre Amplifier	Agilent	8449B	3008A02237	02/23/2011	(1)
Horn Antenna	SCHWARZBECK MESS-ELEKTRONIK	9120D	9120D-550	06/29/2011	(1)
Test Site	ATL	TE01	888001	07/30/2010	-----

Remark: ⁽¹⁾ Calibration period 1 year. ⁽²⁾ Calibration period 2 years.

NOTE: N.C.R. = No Calibration Request.

10.4. Test Procedure

The EUT was setup to ANSI C63.4, 2009; tested to DTS test procedure of Oct 2002 KDB558074 for compliance to FCC 47CFR 15.247 requirements.

The emissions on the harmonics frequencies, the limits, and the margin of compliance are presented. These tests were made when the transmitter was in full radiated power. The additional test was performed to show compliance with the requirement at the band-edge frequency 2483.5 MHz and up to 2500 MHz and at 2390.0 MHz.

The transmitter was configured with the worst case antenna and setup to transmit at the highest channel. Then the field strength was measured at 2483.5 MHz.

The transmitter was then configured with the worst case antenna and setup to transmit at the lowest channel. Then the field strength was measured at 2390.0 MHz. These tests were performed at 4 different bit rates.

For measurements the resolution bandwidth is set to 1 MHz, and then the video bandwidth is set to 1 MHz for peak measurements and 10 Hz for average measurements.

10.5.Test Result

Standard:	FCC Part 15C	Test Distance:	3m
Test item:	Radiated Emission	Power:	AC 120V/60Hz
Model Number:	MZ505	Temp.(°C)/Hum.(%RH):	26(°C)/60%RH
Mode:	Mode 2	Date:	07/13/2011
Frequency:	2412 MHz	Test By:	Gary Wu
Ant.Polar.:	Horizontal		

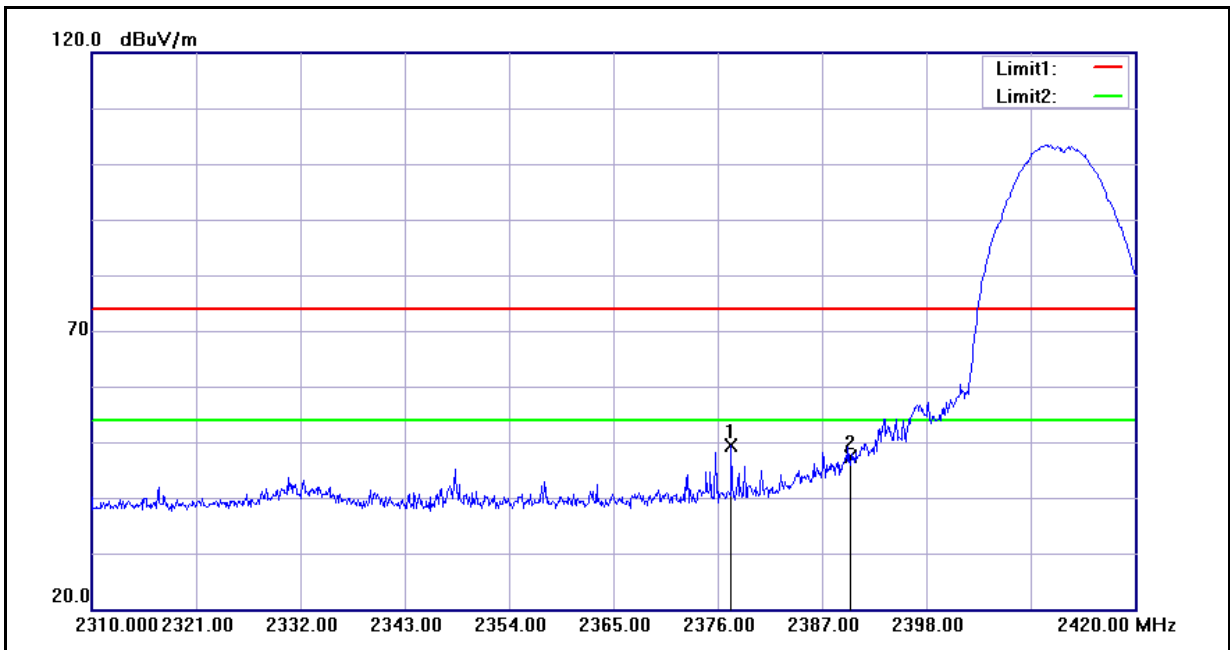

No.	Frequency (MHz)	Reading (dBuV)	Correct Factor(dB/m)	Result (dBuV/m)	Limit (dBuV/m)	Margin (dB)	Remark
1	2377.430	49.54	-0.27	49.27	74.00	-24.73	peak
2	2390.000	47.58	-0.22	47.36	74.00	-26.64	peak

Standard:	FCC Part 15C	Test Distance:	3m
Test item:	Radiated Emission	Power:	AC 120V/60Hz
Model Number:	MZ505	Temp.(°C)/Hum.(%RH):	26(°C)/60%RH
Mode:	Mode 2	Date:	07/13/2011
Frequency:	2412 MHz	Test By:	Gary Wu
Ant.Polar.:	Vertical		

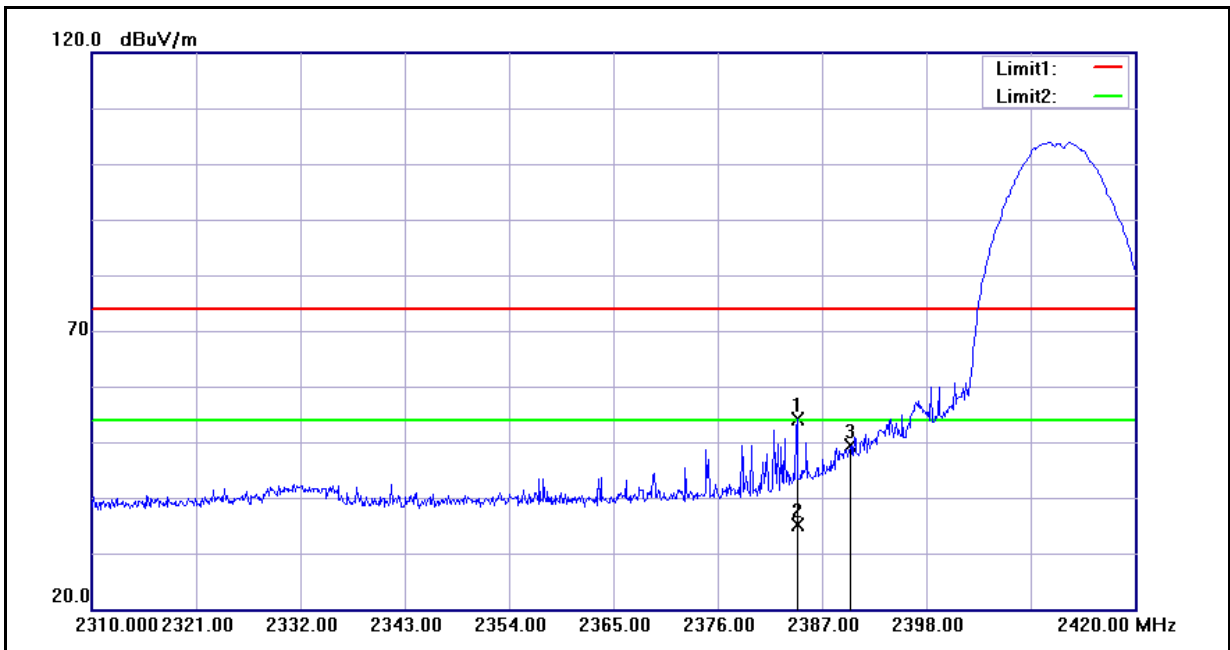

No.	Frequency (MHz)	Reading (dBuV)	Correct Factor(dB/m)	Result (dBuV/m)	Limit (dBuV/m)	Margin (dB)	Remark
1	2384.360	54.39	-0.24	54.15	74.00	-19.85	peak
2	2384.360	35.39	-0.24	35.15	54.00	-18.85	AVG
3	2390.000	49.58	-0.22	49.36	74.00	-24.64	peak

Standard:	FCC Part 15C	Test Distance:	3m
Test item:	Radiated Emission	Power:	AC 120V/60Hz
Model Number:	MZ505	Temp.(°C)/Hum.(%RH):	26(°C)/60%RH
Mode:	Mode 2	Date:	07/13/2011
Frequency:	2462 MHz	Test By:	Gary Wu
Ant.Polar.:	Horizontal		

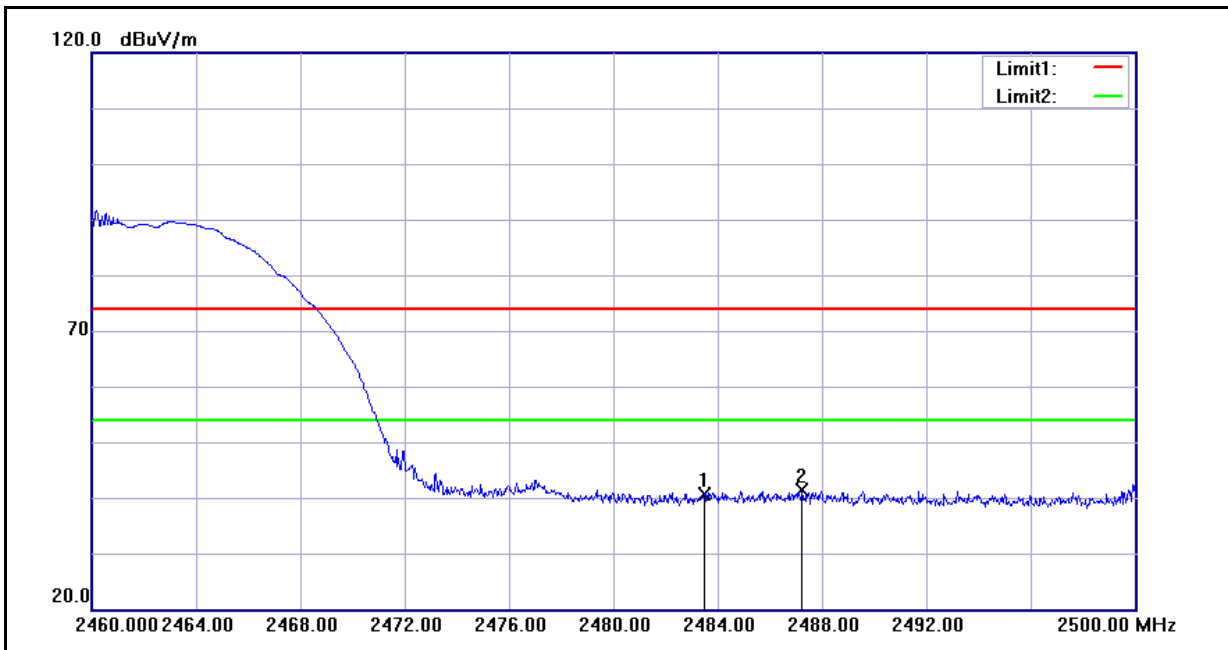

No.	Frequency (MHz)	Reading (dBuV)	Correct Factor(dB/m)	Result (dBuV/m)	Limit (dBuV/m)	Margin (dB)	Remark
1	2483.500	40.50	0.16	40.66	74.00	-33.34	peak
2	2487.240	41.32	0.18	41.50	74.00	-32.50	peak

Standard:	FCC Part 15C	Test Distance:	3m
Test item:	Radiated Emission	Power:	AC 120V/60Hz
Model Number:	MZ505	Temp.(°C)/Hum.(%RH):	26(°C)/60%RH
Mode:	Mode 2	Date:	07/13/2011
Frequency:	2462 MHz	Test By:	Gary Wu
Ant.Polar.:	Vertical		

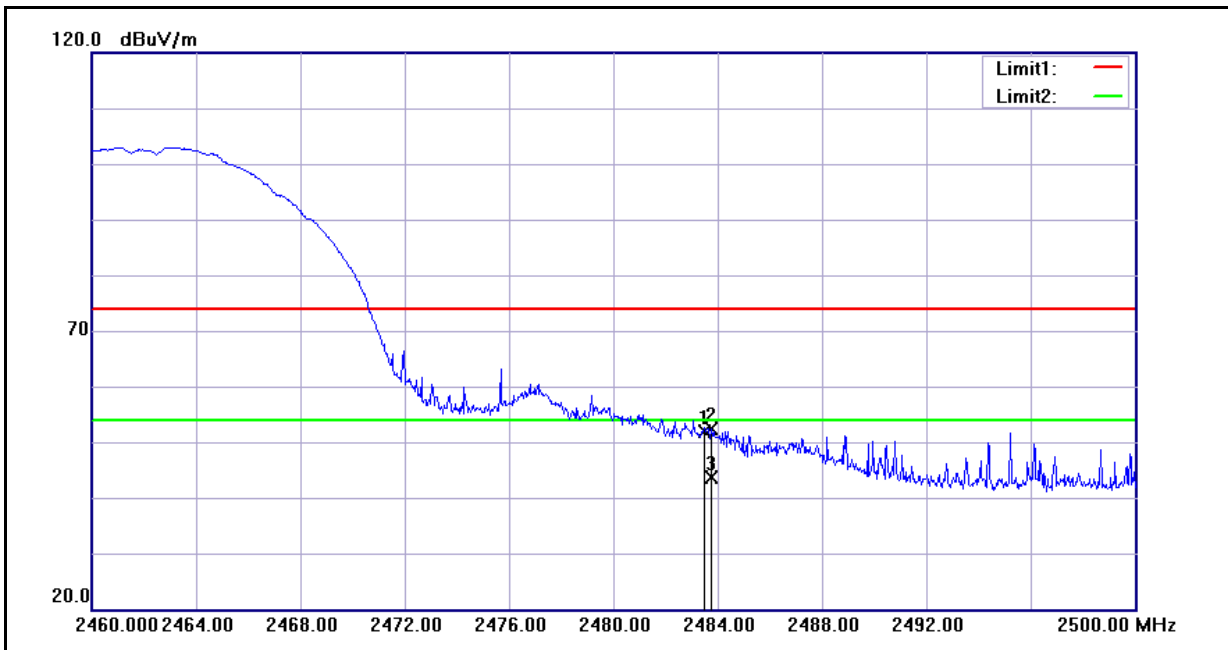

No.	Frequency (MHz)	Reading (dBuV)	Correct Factor(dB/m)	Result (dBuV/m)	Limit (dBuV/m)	Margin (dB)	Remark
1	2483.500	51.75	0.16	51.91	74.00	-22.09	peak
2	2483.760	52.28	0.16	52.44	74.00	-21.56	peak
3	2483.760	43.56	0.16	43.72	54.00	-10.28	AVG

Standard:	FCC Part 15C	Test Distance:	3m
Test item:	Radiated Emission	Power:	AC 120V/60Hz
Model Number:	MZ505	Temp.(°C)/Hum.(%RH):	26(°C)/60%RH
Mode:	Mode 3	Date:	07/13/2011
Frequency:	2412 MHz	Test By:	Gary Wu
Ant.Polar.:	Horizontal		

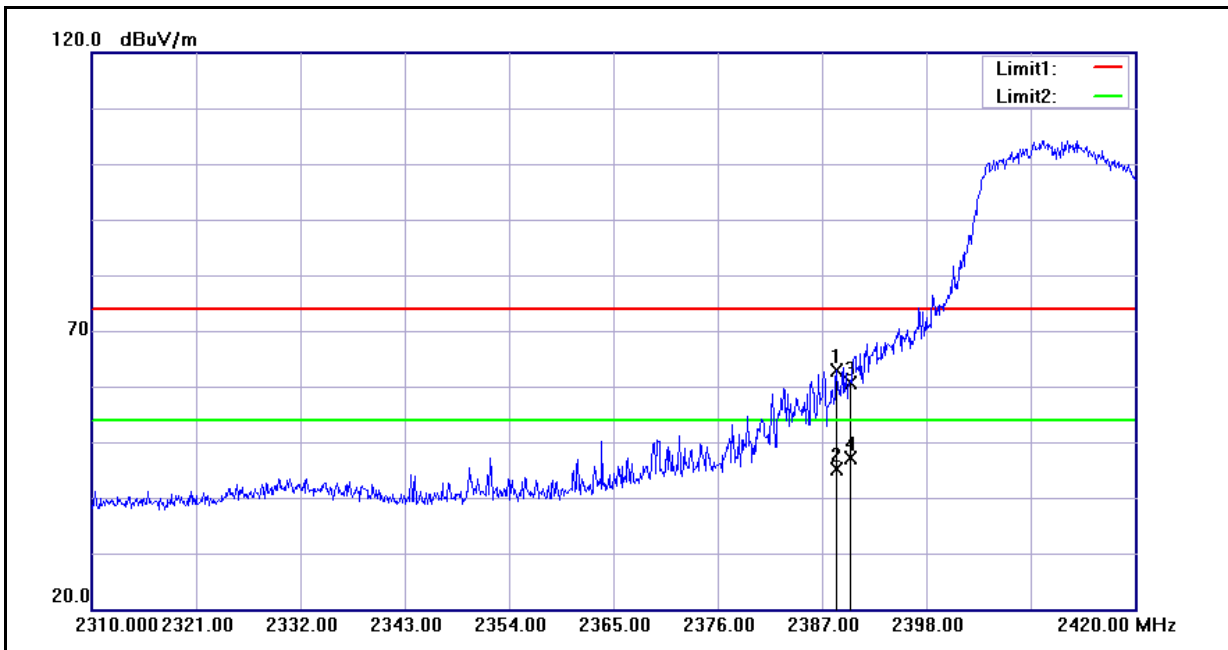

No.	Frequency (MHz)	Reading (dBuV)	Correct Factor(dB/m)	Result (dBuV/m)	Limit (dBuV/m)	Margin (dB)	Remark
1	2388.540	63.05	-0.22	62.83	74.00	-11.17	peak
2	2388.540	45.23	-0.22	45.01	54.00	-8.99	AVG
3	2390.000	60.84	-0.22	60.62	74.00	-13.38	peak
4	2390.000	47.33	-0.22	47.11	54.00	-6.89	AVG

Standard:	FCC Part 15C	Test Distance:	3m
Test item:	Radiated Emission	Power:	AC 120V/60Hz
Model Number:	MZ505	Temp.(°C)/Hum.(%RH):	26(°C)/60%RH
Mode:	Mode 3	Date:	07/13/2011
Frequency:	2412 MHz	Test By:	Gary Wu
Ant.Polar.:	Vertical		

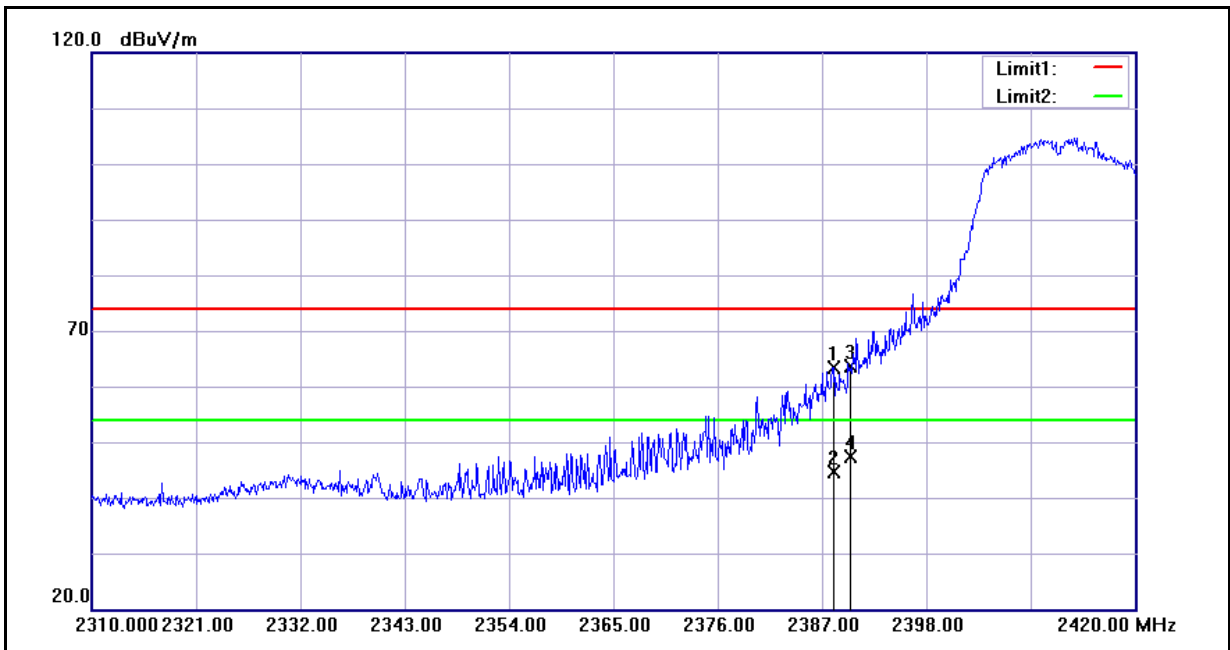

No.	Frequency (MHz)	Reading (dBuV)	Correct Factor(dB/m)	Result (dBuV/m)	Limit (dBuV/m)	Margin (dB)	Remark
1	2388.210	63.51	-0.22	63.29	74.00	-10.71	peak
2	2388.210	44.75	-0.22	44.53	54.00	-9.47	AVG
3	2390.000	63.92	-0.22	63.70	74.00	-10.30	peak
4	2390.000	47.71	-0.22	47.49	54.00	-6.51	AVG

Standard:	FCC Part 15C	Test Distance:	3m
Test item:	Radiated Emission	Power:	AC 120V/60Hz
Model Number:	MZ505	Temp.(°C)/Hum.(%RH):	26(°C)/60%RH
Mode:	Mode 3	Date:	07/13/2011
Frequency:	2462 MHz	Test By:	Gary Wu
Ant.Polar.:	Horizontal		

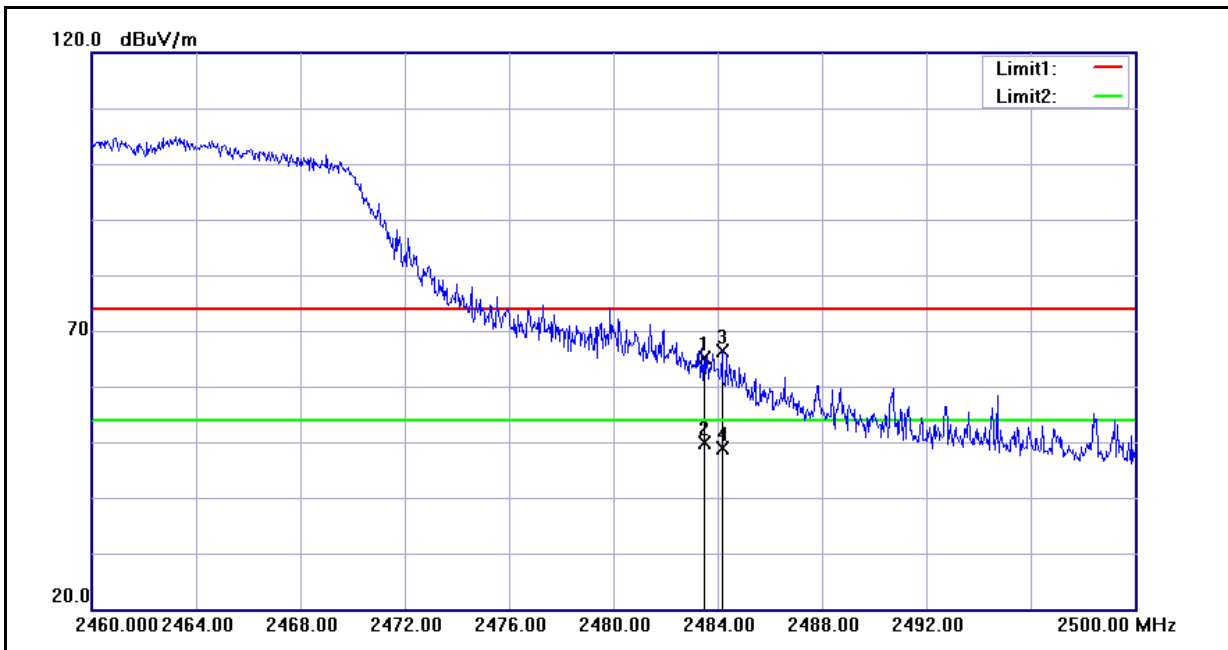

No.	Frequency (MHz)	Reading (dBuV)	Correct Factor(dB/m)	Result (dBuV/m)	Limit (dBuV/m)	Margin (dB)	Remark
1	2483.500	64.86	0.16	65.02	74.00	-8.98	peak
2	2483.500	49.82	0.16	49.98	54.00	-4.02	AVG
3	2484.160	66.21	0.16	66.37	74.00	-7.63	peak
4	2484.160	48.64	0.16	48.80	54.00	-5.20	AVG

Standard:	FCC Part 15C	Test Distance:	3m
Test item:	Radiated Emission	Power:	AC 120V/60Hz
Model Number:	MZ505	Temp.(°C)/Hum.(%RH):	26(°C)/60%RH
Mode:	Mode 3	Date:	07/13/2011
Frequency:	2462 MHz	Test By:	Gary Wu
Ant.Polar.:	Vertical		

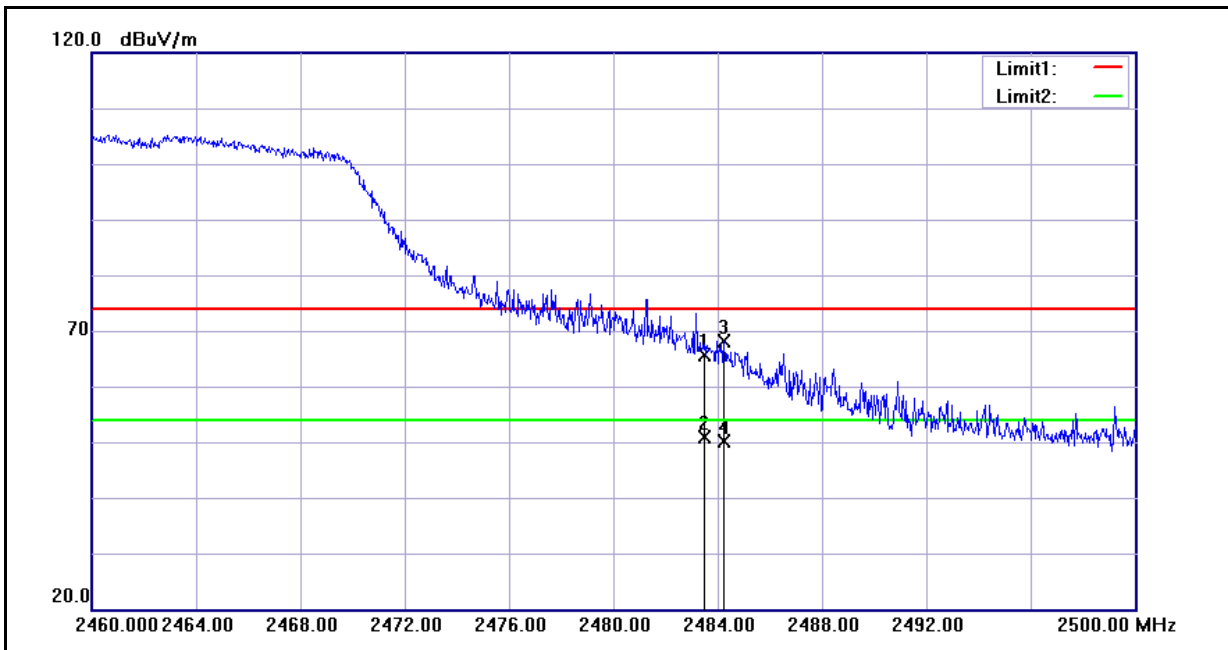

No.	Frequency (MHz)	Reading (dBuV)	Correct Factor(dB/m)	Result (dBuV/m)	Limit (dBuV/m)	Margin (dB)	Remark
1	2483.500	65.47	0.16	65.63	74.00	-8.37	peak
2	2483.500	50.84	0.16	51.00	54.00	-3.00	AVG
3	2484.240	67.91	0.16	68.07	74.00	-5.93	peak
4	2484.240	49.88	0.16	50.04	54.00	-3.96	AVG

Standard:	FCC Part 15C	Test Distance:	3m
Test item:	Radiated Emission	Power:	AC 120V/60Hz
Model Number:	MZ505	Temp.(°C)/Hum.(%RH):	26(°C)/60%RH
Mode:	Mode 4	Date:	07/13/2011
Frequency:	2412 MHz	Test By:	Gary Wu
Ant.Polar.:	Horizontal		

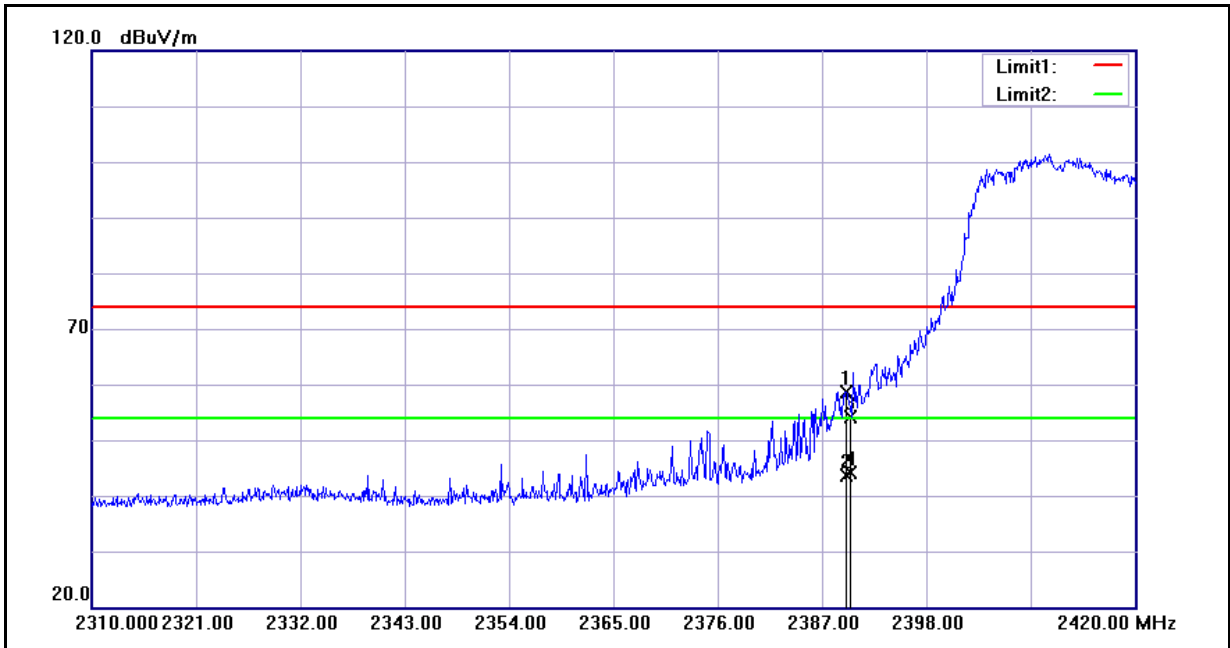

No.	Frequency (MHz)	Reading (dBuV)	Correct Factor(dB/m)	Result (dBuV/m)	Limit (dBuV/m)	Margin (dB)	Remark
1	2389.530	58.95	-0.22	58.73	74.00	-15.27	peak
2	2389.530	43.86	-0.22	43.64	54.00	-10.36	AVG
3	2390.000	54.24	-0.22	54.02	74.00	-19.98	peak
4	2390.000	44.45	-0.22	44.23	54.00	-9.77	AVG

Standard:	FCC Part 15C	Test Distance:	3m
Test item:	Radiated Emission	Power:	AC 120V/60Hz
Model Number:	MZ505	Temp.(°C)/Hum.(%RH):	26(°C)/60%RH
Mode:	Mode 4	Date:	07/13/2011
Frequency:	2412 MHz	Test By:	Gary Wu
Ant.Polar.:	Vertical		

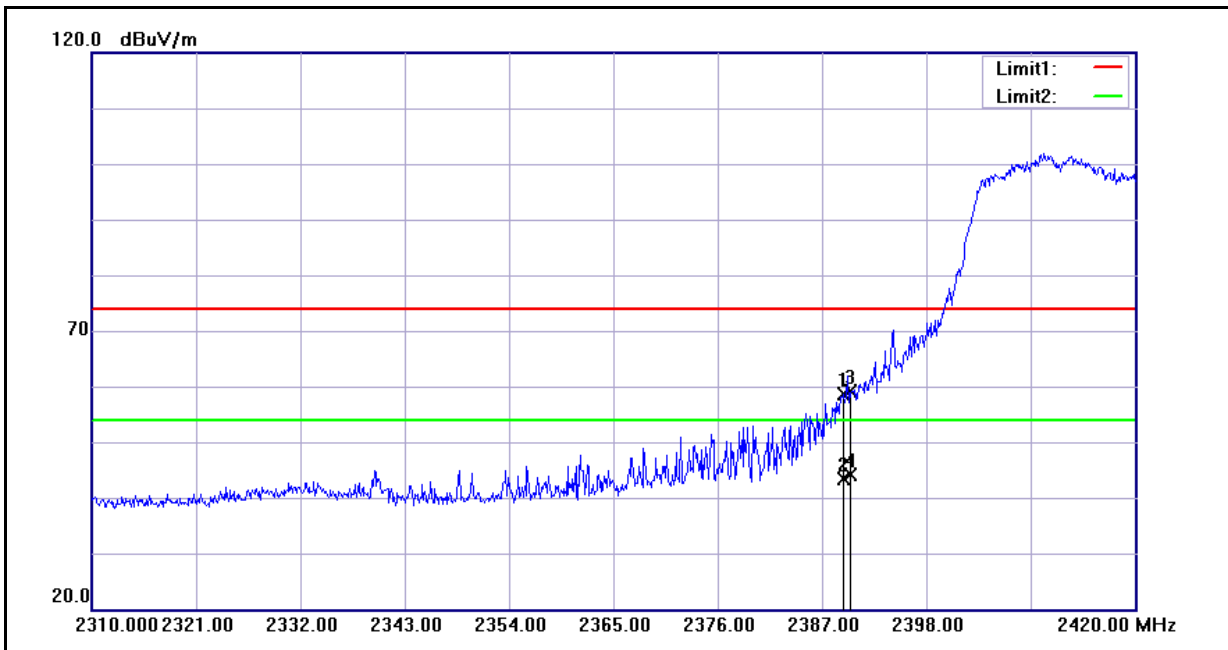

No.	Frequency (MHz)	Reading (dBuV)	Correct Factor(dB/m)	Result (dBuV/m)	Limit (dBuV/m)	Margin (dB)	Remark
1	2389.310	58.80	-0.22	58.58	74.00	-15.42	peak
2	2389.310	43.65	-0.22	43.43	54.00	-10.57	AVG
3	2390.000	59.31	-0.22	59.09	74.00	-14.91	peak
4	2390.000	44.41	-0.22	44.19	54.00	-9.81	AVG

Standard:	FCC Part 15C	Test Distance:	3m
Test item:	Radiated Emission	Power:	AC 120V/60Hz
Model Number:	MZ505	Temp.(°C)/Hum.(%RH):	26(°C)/60%RH
Mode:	Mode 4	Date:	07/13/2011
Frequency:	2462 MHz	Test By:	Gary Wu
Ant.Polar.:	Horizontal		

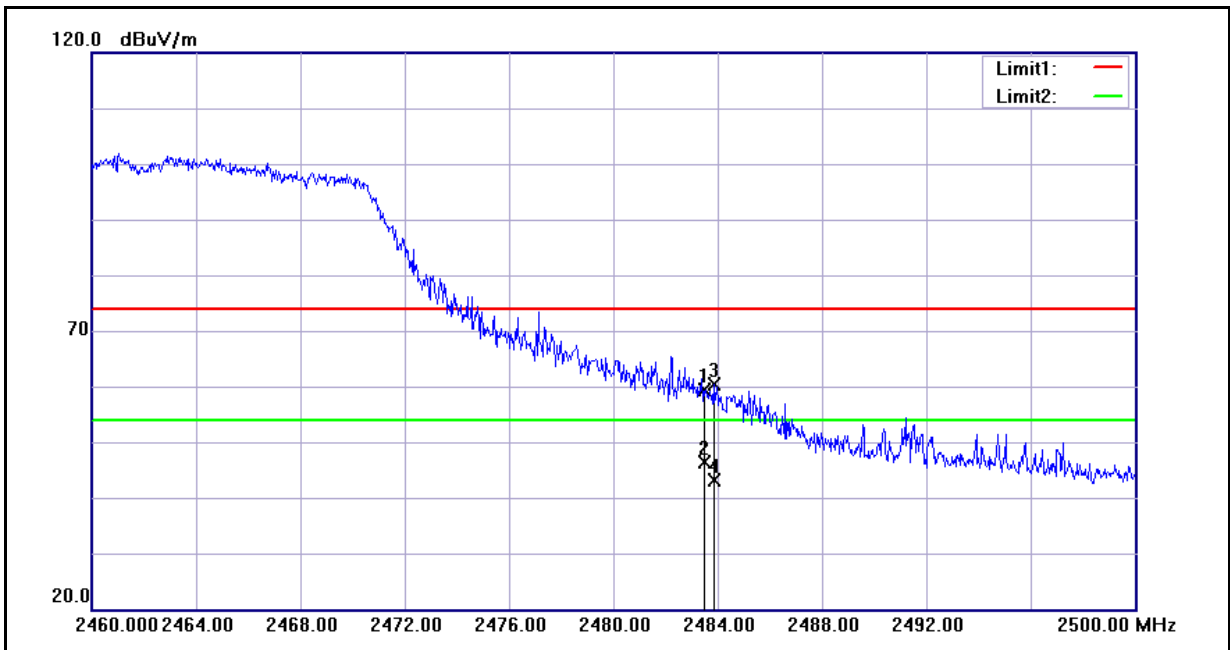

No.	Frequency (MHz)	Reading (dBuV)	Correct Factor(dB/m)	Result (dBuV/m)	Limit (dBuV/m)	Margin (dB)	Remark
1	2483.500	59.15	0.16	59.31	74.00	-14.69	peak
2	2483.500	46.30	0.16	46.46	54.00	-7.54	AVG
3	2483.840	60.19	0.16	60.35	74.00	-13.65	peak
4	2483.840	42.92	0.16	43.08	54.00	-10.92	AVG

Standard:	FCC Part 15C	Test Distance:	3m
Test item:	Radiated Emission	Power:	AC 120V/60Hz
Model Number:	MZ505	Temp.(°C)/Hum.(%RH):	26(°C)/60%RH
Mode:	Mode 4	Date:	07/13/2011
Frequency:	2462 MHz	Test By:	Gary Wu
Ant.Polar.:	Vertical		

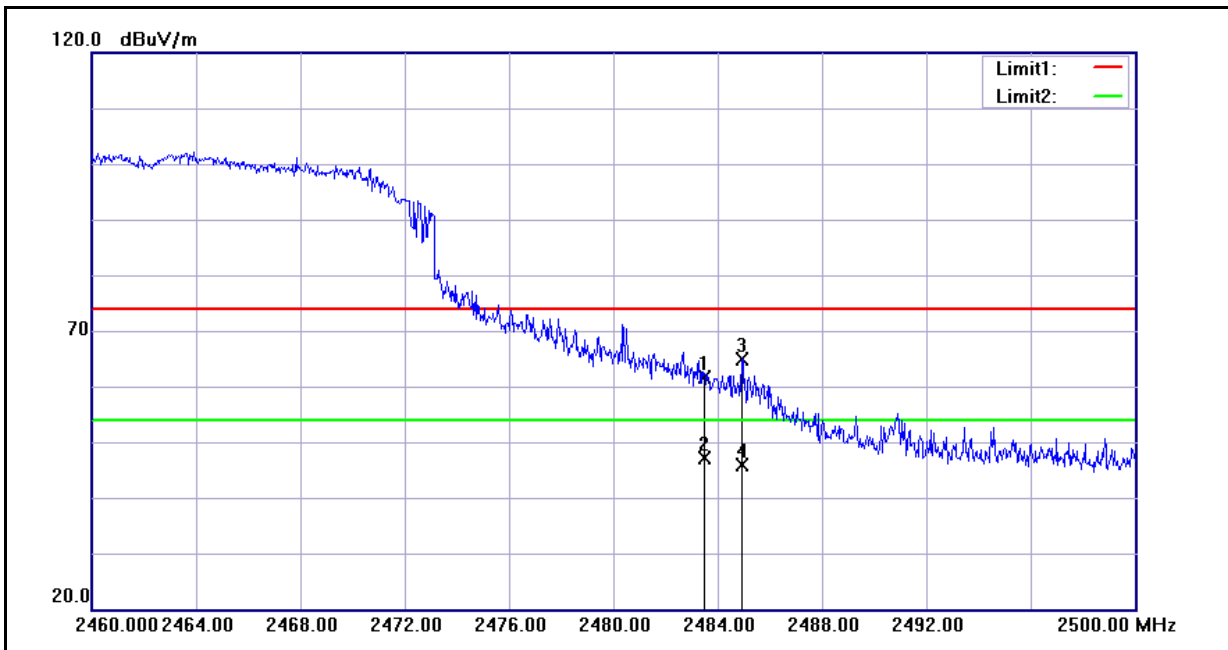

No.	Frequency (MHz)	Reading (dBuV)	Correct Factor(dB/m)	Result (dBuV/m)	Limit (dBuV/m)	Margin (dB)	Remark
1	2483.500	61.36	0.16	61.52	74.00	-12.48	peak
2	2483.500	47.09	0.16	47.25	54.00	-6.75	AVG
3	2484.920	64.64	0.16	64.80	74.00	-9.20	peak
4	2484.920	45.65	0.16	45.81	54.00	-8.19	AVG

11 99 % Occupied Bandwidth Measurement

11.1.Limit

N/A

11.2.Test Setup

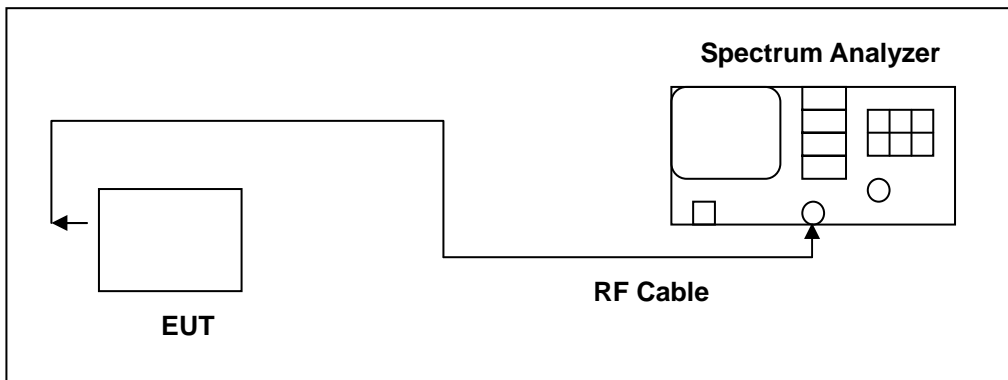

11.3.Test Instruments

Equipment	Manufacturer	Model Number	Serial Number	Cal. Date	Remark
Spectrum Analyzer	Agilent	E4445A	MY45300744	12/28/2010	(2)
Test Site	ATL	TE02	TE02	N.C.R.	-----

Remark: (1) Calibration period 1 year. (2) Calibration period 2 years.

NOTE: N.C.R. = No Calibration Request.

11.4.Test Procedure

The transmitter shall be operated at its maximum carrier power measured under normal test conditions. The span of the analyzer shall be set to capture all products of the modulation process, including the emission skirts. The resolution bandwidth shall be set to as close to 1% of the selected span as is possible without being below 1%. The video bandwidth shall be set to 3 times the resolution bandwidth. Video averaging is not permitted. Where practical, a sampling detector shall be used since a peak or, peak hold, may produce a wider bandwidth than actual.

The trace data points are recovered and are directly summed in linear terms. The recovered amplitude data points, beginning at the lowest frequency, are placed in a running sum until 0.5% of the total is reached and that frequency recorded. The process is repeated for the highest frequency data points. This frequency is recorded.

11.5.Test Result

Model Number	MZ505		
Test Item	99 % Occupied Bandwidth		
Test Mode	Mode 2: IEEE 802.11b Link Mode		
Date of Test	07/06/2011	Test Site	TE02
	Frequency (MHz)	Measurement (MHz)	Limit (kHz)
	2412	12.6653	-----
	2437	12.6622	-----
	2462	12.7011	-----

Model Number	MZ505		
Test Item	99 % Occupied Bandwidth		
Test Mode	Mode 3: IEEE 802.11g Link Mode		
Date of Test	07/06/2011	Test Site	TE02
	Frequency (MHz)	Measurement (MHz)	Limit (kHz)
	2412	16.4867	-----
	2437	16.4768	-----
	2462	16.4239	-----

Model Number	MZ505		
Test Item	99 % Occupied Bandwidth		
Test Mode	Mode 4: draft 802.11n Standard-20MHz Link Mode		
Date of Test	07/06/2011	Test Site	TE02
	Frequency (MHz)	Measurement (MHz)	Limit (kHz)
	2412	17.6512	-----
	2437	17.6940	-----
	2462	17.6840	-----

11.6. Test Graphs

Mode 2: IEEE 802.11b Link Mode	
2412	<p>Agilent T</p> <p>Ch Freq 2.412 GHz Trig Free</p> <p>Occupied Bandwidth</p> <p>Ref 21.4 dBm Atten 30 dB</p> <p>*Samp Log 10 dB/Offst 10.7 dB</p> <p>Center 2.412 00 GHz Span 50 MHz</p> <p>*Res BW 300 kHz *VBW 1 MHz Sweep 1.68 ms (601 pts)</p> <p>Occupied Bandwidth 12.6653 MHz</p> <p>Occ BM % Pwr 99.00 %</p> <p>x dB -26.00 dB</p> <p>Transmit Freq Error 74.714 kHz</p> <p>x dB Bandwidth 16.261 MHz*</p> <p>Copyright 2000-2005 Agilent Technologies</p> <p>Freq/Channel</p> <p>Center Freq 2.41200000 GHz</p> <p>Start Freq 2.38700000 GHz</p> <p>Stop Freq 2.43700000 GHz</p> <p>CF Step 5.00000000 MHz</p> <p>Auto Man</p> <p>Freq Offset 0.00000000 Hz</p> <p>Signal Track On Off</p>
2437	<p>Agilent T</p> <p>Ch Freq 2.437 GHz Trig Free</p> <p>Occupied Bandwidth</p> <p>Ref 21.4 dBm Atten 30 dB</p> <p>*Samp Log 10 dB/Offst 10.7 dB</p> <p>Center 2.437 00 GHz Span 50 MHz</p> <p>*Res BW 300 kHz *VBW 1 MHz Sweep 1.68 ms (601 pts)</p> <p>Occupied Bandwidth 12.6622 MHz</p> <p>Occ BM % Pwr 99.00 %</p> <p>x dB -26.00 dB</p> <p>Transmit Freq Error 53.251 kHz</p> <p>x dB Bandwidth 16.277 MHz*</p> <p>Copyright 2000-2005 Agilent Technologies</p> <p>Freq/Channel</p> <p>Center Freq 2.43700000 GHz</p> <p>Start Freq 2.41200000 GHz</p> <p>Stop Freq 2.46200000 GHz</p> <p>CF Step 5.00000000 MHz</p> <p>Auto Man</p> <p>Freq Offset 0.00000000 Hz</p> <p>Signal Track On Off</p>
2462	<p>Agilent T</p> <p>Ch Freq 2.462 GHz Trig Free</p> <p>Occupied Bandwidth</p> <p>Ref 21.4 dBm Atten 30 dB</p> <p>*Samp Log 10 dB/Offst 10.7 dB</p> <p>Center 2.462 00 GHz Span 50 MHz</p> <p>*Res BW 300 kHz *VBW 1 MHz Sweep 1.68 ms (601 pts)</p> <p>Occupied Bandwidth 12.7011 MHz</p> <p>Occ BM % Pwr 99.00 %</p> <p>x dB -26.00 dB</p> <p>Transmit Freq Error 44.936 kHz</p> <p>x dB Bandwidth 16.283 MHz*</p> <p>Copyright 2000-2005 Agilent Technologies</p> <p>Freq/Channel</p> <p>Center Freq 2.46200000 GHz</p> <p>Start Freq 2.43700000 GHz</p> <p>Stop Freq 2.48700000 GHz</p> <p>CF Step 5.00000000 MHz</p> <p>Auto Man</p> <p>Freq Offset 0.00000000 Hz</p> <p>Signal Track On Off</p>

Mode 3: IEEE 802.11g Link Mode

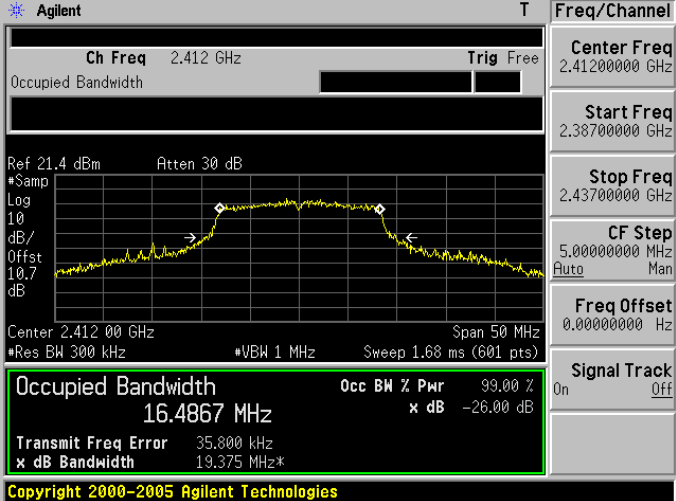
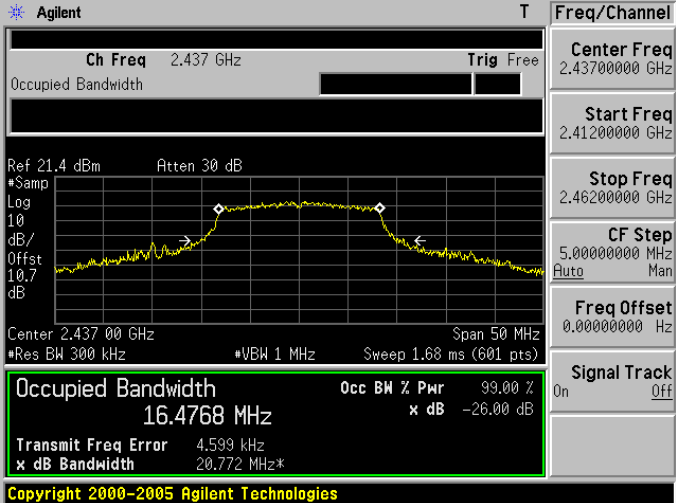
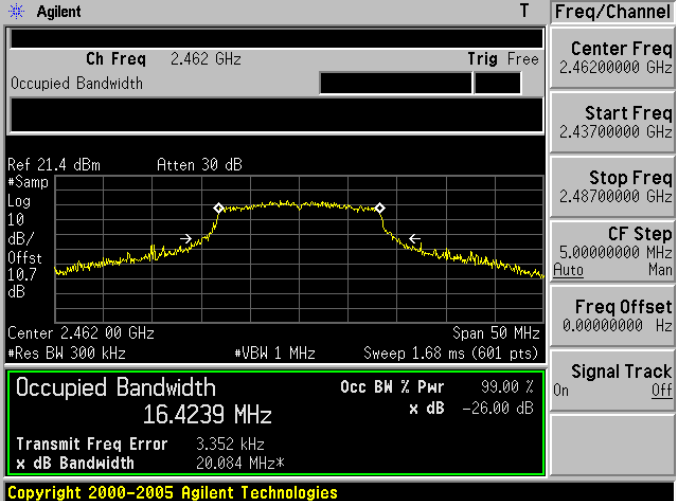
2412	 <p>Agilent T</p> <p>Ch Freq 2.412 GHz Trig Free</p> <p>Center Freq 2.41200000 GHz</p> <p>Start Freq 2.38700000 GHz</p> <p>Stop Freq 2.43700000 GHz</p> <p>CF Step 5.00000000 MHz</p> <p>Freq Offset 0.00000000 Hz</p> <p>Signal Track On Off</p> <p>Occupied Bandwidth 16.4867 MHz</p> <p>Transmit Freq Error 35.800 kHz</p> <p>x dB Bandwidth 19.375 MHz*</p> <p>Occ BM % Pwr 99.00 %</p> <p>x dB -26.00 dB</p> <p>Copyright 2000-2005 Agilent Technologies</p>
2437	 <p>Agilent T</p> <p>Ch Freq 2.437 GHz Trig Free</p> <p>Center Freq 2.43700000 GHz</p> <p>Start Freq 2.41200000 GHz</p> <p>Stop Freq 2.46200000 GHz</p> <p>CF Step 5.00000000 MHz</p> <p>Freq Offset 0.00000000 Hz</p> <p>Signal Track On Off</p> <p>Occupied Bandwidth 16.4768 MHz</p> <p>Transmit Freq Error 4.599 kHz</p> <p>x dB Bandwidth 20.772 MHz*</p> <p>Occ BM % Pwr 99.00 %</p> <p>x dB -26.00 dB</p> <p>Copyright 2000-2005 Agilent Technologies</p>
2462	 <p>Agilent T</p> <p>Ch Freq 2.462 GHz Trig Free</p> <p>Center Freq 2.46200000 GHz</p> <p>Start Freq 2.43700000 GHz</p> <p>Stop Freq 2.48700000 GHz</p> <p>CF Step 5.00000000 MHz</p> <p>Freq Offset 0.00000000 Hz</p> <p>Signal Track On Off</p> <p>Occupied Bandwidth 16.4239 MHz</p> <p>Transmit Freq Error 3.352 kHz</p> <p>x dB Bandwidth 20.084 MHz*</p> <p>Occ BM % Pwr 99.00 %</p> <p>x dB -26.00 dB</p> <p>Copyright 2000-2005 Agilent Technologies</p>

Mode 4: draft 802.11n Standard-20MHz Link Mode

2412	
2437	
2462	

12 Antenna Measurement

12.1.Limit

For intentional device, according to 15.203, an intentional radiator shall be designed to ensure that no antenna other than that furnished by the responsible party shall be used with the device.

And According to 15.247 (b), if transmitting antennas of directional gain greater than 6 dBi are used, the power shall be reduced by the amount in dB that the directional gain of the antenna exceeds 6dBi.

12.2.Antenna Connector Construction

The antenna used in this product is **PIFA antenna**. And the maximum Gain of this antenna is only **0.75 dBi**.