

FCC Test Report

APPLICANT : Motorola Mobility, Inc.
EQUIPMENT : Mobile Phone
BRAND NAME : MOTOROLA
MODEL NAME : XT615
GPPD NUMBER : 3149
FCC ID : IHDP56MM5
STANDARD : FCC 47 CFR FCC Part 15 Subpart B
CLASSIFICATION : Certification

The product was received on Oct. 05, 2011 and completely tested on Oct. 17, 2011. We, SPORTON INTERNATIONAL INC., would like to declare that the tested sample has been evaluated in accordance with the procedures given in ANSI C63.4-2003 and shown the compliance with the applicable technical standards.

The test results in this report apply exclusively to the tested model / sample. Without written approval of SPORTON INTERNATIONAL INC., the test report shall not be reproduced except in full.

Reviewed by:



Jones Tsai / Manager



SPORTON INTERNATIONAL INC.

No. 52, Hwa Ya 1st Rd., Hwa Ya Technology Park, Kwei-Shan Hsiang, Tao Yuan Hsien, Taiwan, R.O.C.



TABLE OF CONTENTS

REVISION HISTORY 3

SUMMARY OF TEST RESULT 4

1. GENERAL DESCRIPTION 5

 1.1. Applicant 5

 1.2. Manufacturer 5

 1.3. Feature of Equipment Under Test 5

 1.4. Test Site 6

 1.5. Applied Standards 6

 1.6. Ancillary Equipment List 6

2. TEST CONFIGURATION OF EQUIPMENT UNDER TEST 7

 2.1. Test Mode 7

 2.2. Connection Diagram of Test System 9

 2.3. Test Software 10

3. TEST RESULT 11

 3.1. Test of AC Conducted Emission Measurement 11

 3.2. Test of Radiated Emission Measurement 15

4. LIST OF MEASURING EQUIPMENT 21

5. UNCERTAINTY OF EVALUATION 22



REVISION HISTORY

REPORT NO.	VERSION	DESCRIPTION	ISSUED DATE
FC100527A	Rev. 01	Initial issue of report	Nov. 01, 2011



SUMMARY OF TEST RESULT

Report Section	FCC Rule	IC Rule	Description	Limit	Result	Remark
3.1	15.107	7.2.4	AC Conducted Emission	< 15.107 limits < RSS-Gen table 2 limits	PASS	Under limit 6.6 dB at 3.926 MHz
3.2	15.109	7.2.3.2	Radiated Emission	< 15.109 limits or < RSS-Gen table 1 limits (Section 6)	PASS	Under limit 6.04 dB at 51.33 MHz

1. General Description

1.1. Applicant

Motorola Mobility, Inc.

8F., No. 9, Songgao Rd., Taipei 110, Taiwan, R.O.C.

1.2. Manufacturer

Chi Mei Communication Systems, Inc.

No. 4, Mingsheng Street, Tucheng District, New Taipei City, 23678, Taiwan

1.3. Feature of Equipment Under Test

Product Feature & Specification	
Equipment	Mobile Phone
Brand Name	MOTOROLA
Model Name	XT615
FCC ID	IHDP56MM5
Tx Frequency Range	GSM850 : 824 MHz ~ 849 MHz GSM1900 : 1850 MHz ~ 1910 MHz Bluetooth : 2400 MHz ~ 2483.5 MHz WLAN : 2400 MHz ~ 2483.5 MHz
Rx Frequency Range	GSM850 : 869 MHz ~ 894 MHz GSM1900 : 1930 MHz ~ 1990 MHz Bluetooth : 2400 MHz ~ 2483.5 MHz WLAN : 2400 MHz ~ 2483.5 MHz GPS : 1.57542 GHz
Antenna Type	WWAN : Fixed Internal Antenna WLAN / Bluetooth : PIFA Antenna
HW Version	PR2
SW Version	V1.250
Type of Modulation	GSM: GMSK GPRS: GMSK EDGE: GMSK / 8PSK Bluetooth (1Mbps) : GFSK Bluetooth EDR (2Mbps) : $\pi/4$ -DQPSK Bluetooth EDR (3Mbps) : 8-DPSK 802.11b : DSSS (BPSK / QPSK / CCK) 802.11g/n : OFDM (BPSK / QPSK / 16QAM / 64QAM) GPS : BPSK
EUT Stage	Identical Prototype

Remark: The above EUT's information was declared by manufacturer. Please refer to the specifications or user's manual for more detailed description.

1.4. Test Site

Test Site	SPORTON INTERNATIONAL INC.		
Test Site Location	No. 52, Hwa Ya 1 st Rd., Hwa Ya Technology Park, Kwei-Shan Hsiang, Tao Yuan Hsien, Taiwan, R.O.C. TEL: +886-3-327-3456 FAX: +886-3-328-4978		
Test Site No.	Sporton Site No.		FCC/IC Registration No.
	CO05-HY	03CH06-HY	722060/4086B-1

1.5. Applied Standards

According to the specifications of the manufacturer, the EUT must comply with the requirements of the following standards:

- FCC 47 CFR FCC Part 15 Subpart B
- ANSI C63.4-2003
- IC RSS-Gen Issue 3

Remark: All test items were verified and recorded according to the standards and without any deviation during the test.

1.6. Ancillary Equipment List

Item	Equipment	Trade Name	Model Name	FCC ID	Data Cable	Power Cord
1.	System Simulator	R&S	CMU 200	N/A	N/A	Unshielded, 1.8 m
2.	GPS Station	Pendulum	GSG-54	N/A	N/A	Unshielded, 1.8 m
3.	WLAN AP	D-Link	DIR-628	KA2DIR628A2	N/A	Unshielded, 1.8 m
4.	Bluetooth Earphone	Nokia	BH-102	PYAHS-107W	N/A	N/A
5.	Notebook	DELL	P20G	FCC DoC	N/A	AC I/P: Unshielded, 1.2 m DC O/P: Shielded, 1.8 m
6.	LCD Monitor	Lenovo	6135-AB1	FCC DoC	Shielded, 1.6 m	Unshielded, 1.8 m
7.	iPod	Apple	A1285	FCC DoC	Shielded, 1.0 m	N/A
8.	iPod	Apple	A1199	FCC DoC	Shielded, 1.0 m	N/A

2. Test Configuration of Equipment Under Test

2.1. Test Mode

The EUT has been associated with peripherals pursuant to ANSI C63.4-2003 and configuration operated in a manner tended to maximize its emission characteristics in a typical application.

Frequency range investigated: conduction (150 kHz to 30 MHz), radiation (30MHz to the 5th harmonic of the highest fundamental frequency or to 40 GHz, whichever is lower).

The EUT uses a USB interface and microprocessor operating 800MHz which is the maximum frequency used.

The following tables are showing the test modes as the worst cases and recorded in this report.

Item	EUT Configuration	Test Condition		
		EMI AC	EMI RE<1G	EMI RE≥1G
1.	Charging Mode (EUT with adapter)	☒	☒	☒
2.	Data application transferred mode (EUT with notebook)	☒	☒	☒

Abbreviations:

- EMI AC: AC conducted emissions
- EMI RE ≥ 1G: EUT radiated emissions ≥ 1GHz
- EMI RE < 1G: EUT radiated emissions < 1GHz

Test Items	EUT Configure Mode	Function Type
AC Conducted Emission	1/2	Mode 1: GSM850 Idle + Bluetooth Idle + WLAN Idle + GPS Rx + Adapter + Earphone + MP3 + Battery <Fig. 1> Mode 2: GSM1900 Idle + Bluetooth Idle + WLAN Idle + Adapter + Earphone + Camera + Battery <Fig. 2> Mode 3: GSM850 Idle + Bluetooth Idle + WLAN Idle + GPS Rx + Earphone + Battery + USB Cable (Data Link with Notebook) <Fig. 3>
Radiated Emissions < 1GHz	1/2	Mode 1: GSM850 Idle + Bluetooth Idle + WLAN Idle + GPS Rx + Adapter + Earphone + MP3 + Battery <Fig. 1> Mode 2: GSM1900 Idle + Bluetooth Idle + WLAN Idle + Adapter + Earphone + Camera + Battery <Fig. 2> Mode 3: GSM850 Idle + Bluetooth Idle + WLAN Idle + GPS Rx + Earphone + Battery + USB Cable (Data Link with Notebook) <Fig. 3>
Radiated Emissions ≥ 1GHz	1	Mode 1: GSM1900 Idle + Bluetooth Idle + WLAN Idle + Adapter + Earphone + Camera + Battery <Fig. 2> Mode 2: GSM850 Idle + Bluetooth Idle + WLAN Idle + GPS Rx + Earphone + Battery + USB Cable (Data Link with Notebook) <Fig. 3>
<p>Remark:</p> <ol style="list-style-type: none"> 1. The worst case of AC is mode 1; only the test data of this mode was reported. 2. The worst case of RE < 1G is mode 2; the test data of this mode was reported. 3. The USB Link mode is mode 3; the test data of this mode was reported. 4. Link with Notebook means data application transferred mode between EUT and Notebook. 		

2.2. Connection Diagram of Test System

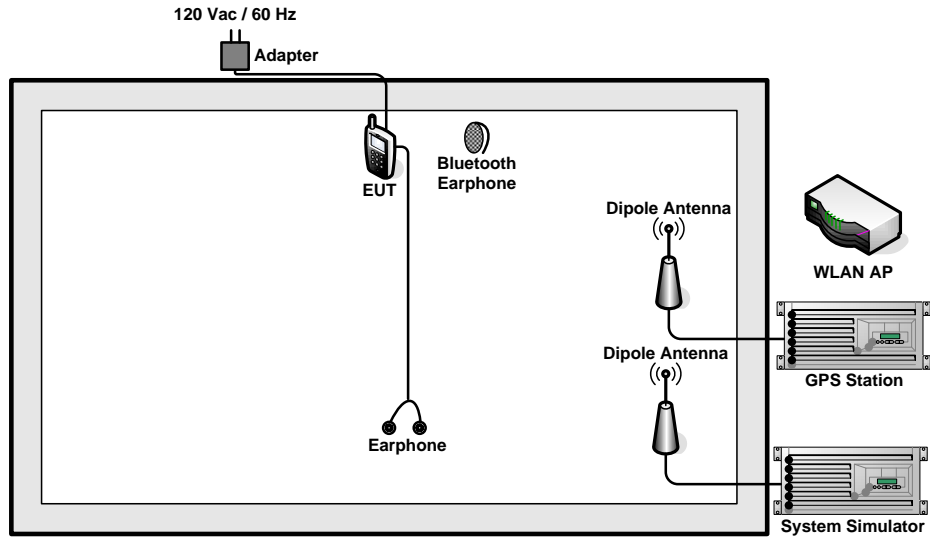

<Fig. 1>

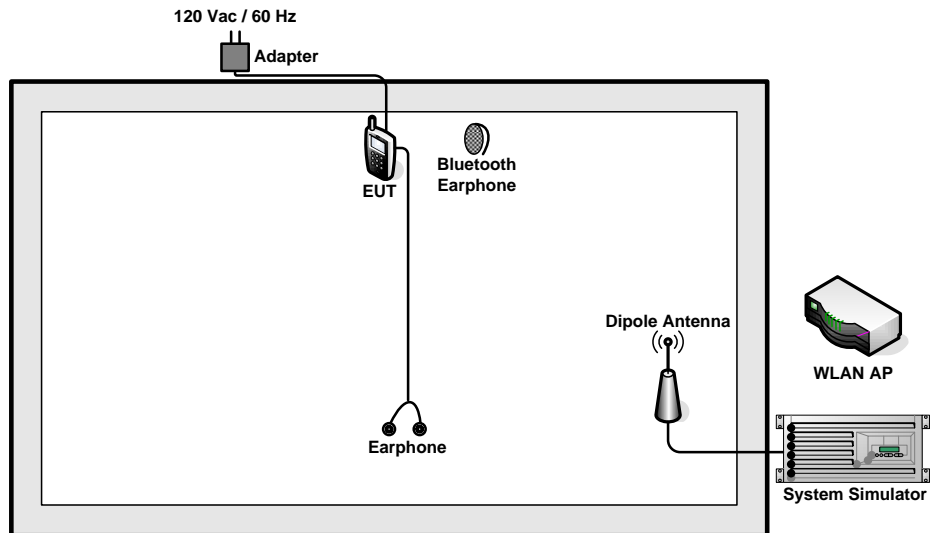

<Fig. 2>

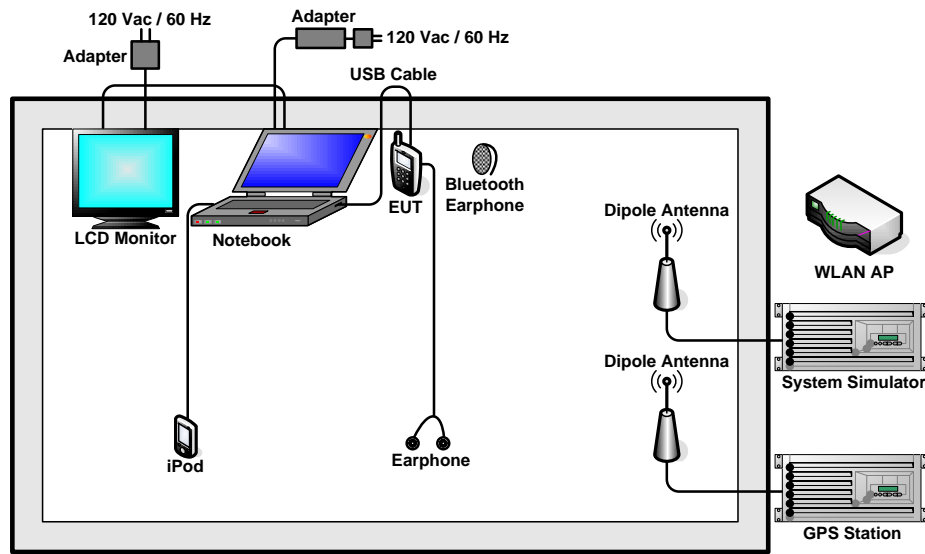

<Fig. 3>

2.3. Test Software

The EUT was in GSM idle mode during the testing. The EUT was synchronized to the BCCH, and is in continuous receiving mode by setting system simulator's paging reorganization.

At the same time, the EUT was attached to the Bluetooth earphone or WLAN AP, and the following programs installed in the EUT were programmed during the test.

1. Execute the program, "Winthrx.exe", installed in notebook for active sync files transfer with EUT via USB cable.
2. Execute "GPS Test" to make the EUT receive signals from GPS station continuously.
3. Execute "Music Player" to play MP3 file.
4. Turn on camera to capture images.

3. Test Result

3.1. Test of AC Conducted Emission Measurement

3.1.1 Limits of AC Conducted Emission

For equipment that is designed to be connected to the public utility (AC) power line, the radio frequency voltage that is conducted back onto the AC power line on any frequency or frequencies within the band 150 kHz to 30 MHz shall not exceed the limits in the following table.

Frequency of emission (MHz)	Conducted limit (dBuV)	
	Quasi-peak	Average
0.15-0.5	66 to 56*	56 to 46*
0.5-5	56	46
5-30	60	50

*Decreases with the logarithm of the frequency.

3.1.2 Measuring Instruments

See list of measuring instruments of this test report.

3.1.3 Test Procedure

1. The EUT was placed 0.4 meter from the conducting wall of the shielding room was kept at least 80 centimeters from any other grounded conducting surface.
2. Connect EUT to the power mains through a line impedance stabilization network (LISN).
3. All the support units are connecting to the other LISN.
4. The LISN provides 50 ohm coupling impedance for the measuring instrument.
5. The FCC states that a 50 ohm, 50 microhenry LISN should be used.
6. Both sides of AC line were checked for maximum conducted interference.
7. The frequency range from 150 kHz to 30 MHz was searched.
8. Set the test-receiver system to Peak Detect Function and specified bandwidth with Maximum Hold Mode.

3.1.4 Test Setup

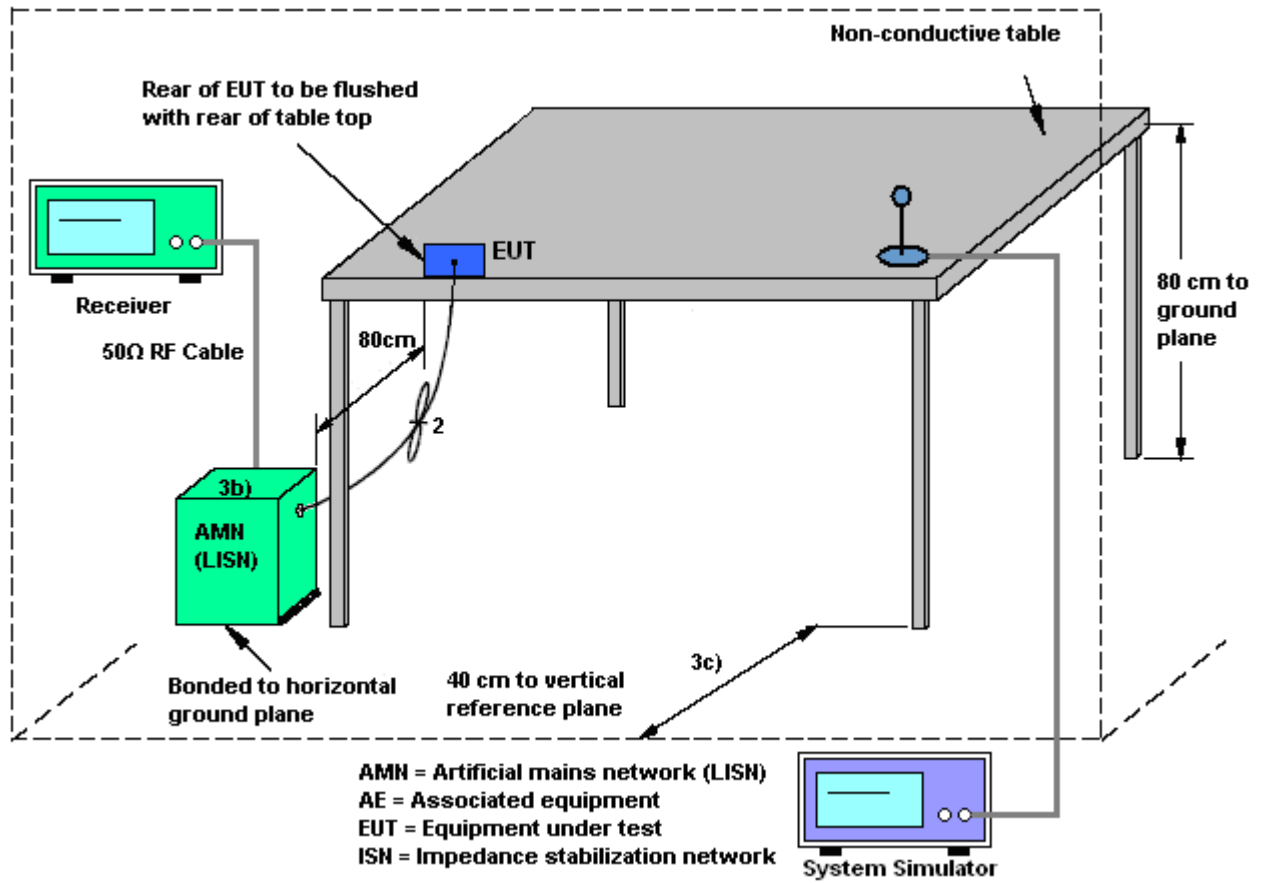

3.1.5 Test Result of AC Conducted Emission

Test Mode :	Mode 1	Temperature :	20~22°C
Test Engineer :	Kai-Chun Chu	Relative Humidity :	40~42%
Test Voltage :	120Vac / 60Hz	Phase :	Line
Function Type :	GSM850 Idle + Bluetooth Idle + WLAN Idle + GPS Rx + Adapter + Earphone + MP3 + Battery		
Remark :	All emissions not reported here are more than 10 dB below the prescribed limit.		

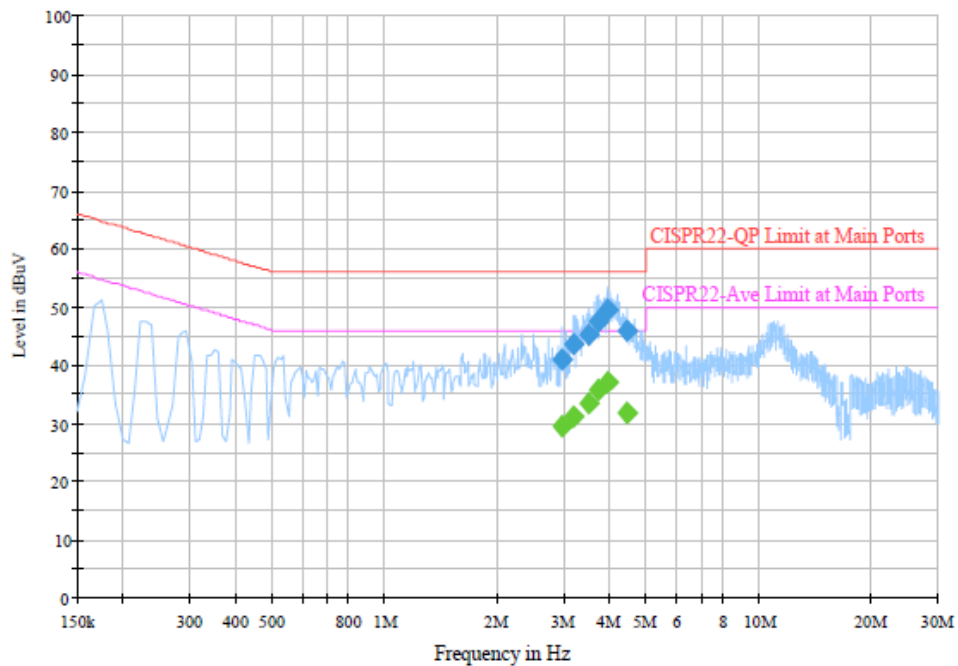

Final Result 1

Frequency (MHz)	QuasiPeak (dBµV)	Filter	Line	Corr. (dB)	Margin (dB)	Limit (dBµV)
2.974000	41.1	Off	L1	19.4	14.9	56.0
3.198000	43.5	Off	L1	19.5	12.5	56.0
3.494000	45.2	Off	L1	19.5	10.8	56.0
3.686000	47.7	Off	L1	19.5	8.3	56.0
3.926000	49.4	Off	L1	19.5	6.6	56.0
4.406000	45.8	Off	L1	19.5	10.2	56.0

Final Result 2

Frequency (MHz)	Average (dBµV)	Filter	Line	Corr. (dB)	Margin (dB)	Limit (dBµV)
2.974000	29.5	Off	L1	19.4	16.5	46.0
3.198000	31.2	Off	L1	19.5	14.8	46.0
3.494000	33.4	Off	L1	19.5	12.6	46.0
3.686000	35.8	Off	L1	19.5	10.2	46.0
3.926000	37.0	Off	L1	19.5	9.0	46.0
4.406000	31.9	Off	L1	19.5	14.1	46.0



Test Mode :	Mode 1	Temperature :	20~22°C
Test Engineer :	Kai-Chun Chu	Relative Humidity :	40~42%
Test Voltage :	120Vac / 60Hz	Phase :	Neutral
Function Type :	GSM850 Idle + Bluetooth Idle + WLAN Idle + GPS Rx + Adapter + Earphone + MP3 + Battery		
Remark :	All emissions not reported here are more than 10 dB below the prescribed limit.		

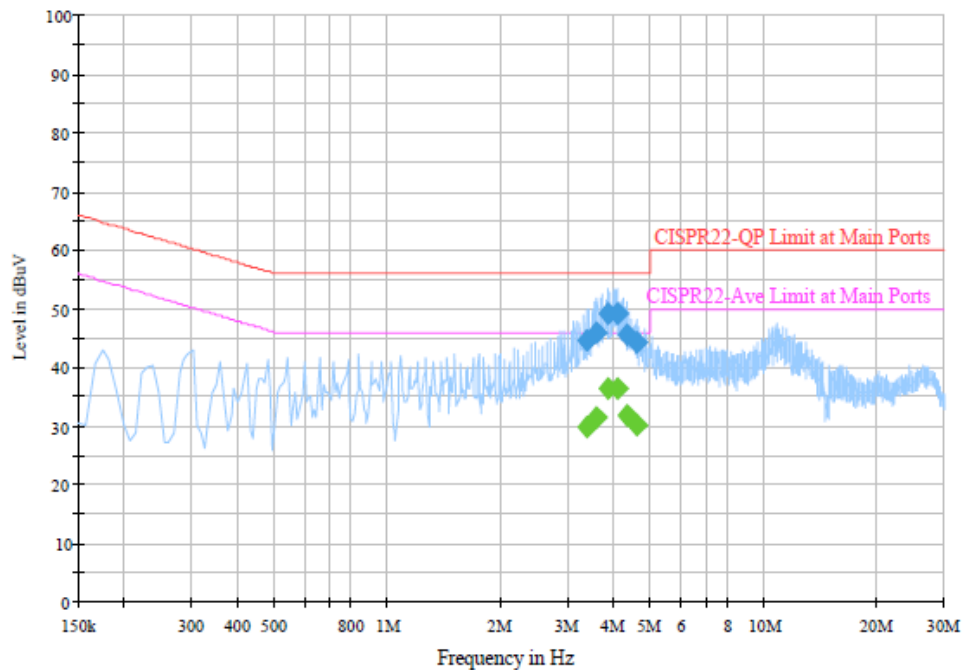

Final Result 1

Frequency (MHz)	QuasiPeak (dBµV)	Filter	Line	Corr. (dB)	Margin (dB)	Limit (dBµV)
3.358000	44.6	Off	N	19.5	11.4	56.0
3.598000	45.8	Off	N	19.5	10.2	56.0
3.838000	49.2	Off	N	19.5	6.8	56.0
4.078000	49.3	Off	N	19.5	6.7	56.0
4.318000	45.7	Off	N	19.5	10.3	56.0
4.558000	44.2	Off	N	19.5	11.8	56.0

Final Result 2

Frequency (MHz)	Average (dBµV)	Filter	Line	Corr. (dB)	Margin (dB)	Limit (dBµV)
3.358000	29.9	Off	N	19.5	16.1	46.0
3.598000	31.5	Off	N	19.5	14.5	46.0
3.838000	36.3	Off	N	19.5	9.7	46.0
4.078000	36.5	Off	N	19.5	9.5	46.0
4.318000	31.7	Off	N	19.5	14.3	46.0
4.558000	30.2	Off	N	19.5	15.8	46.0

3.2. Test of Radiated Emission Measurement

3.2.1. Limit of Radiated Emission

The emissions from an intentional radiator shall not exceed the field strength levels specified in the following table:

Frequency (MHz)	Field Strength (microvolts/meter)	Measurement Distance (meters)
0.009 – 0.490	2400/F(kHz)	300
0.490 – 1.705	24000/F(kHz)	30
1.705 – 30.0	30	30
30 – 88	100	3
88 – 216	150	3
216 - 960	200	3
Above 960	500	3

3.2.2. Measuring Instruments

See list of measuring instruments of this test report.

3.2.3. Test Procedures

1. The EUT was placed on a turntable with 0.8 meter above ground.
2. The EUT was set 3 meters from the interference receiving antenna, which was mounted on the top of a variable height antenna tower.
3. The table was rotated 360 degrees to determine the position of the highest radiation.
4. The antenna is a Bi-Log antenna and its height is adjusted between one meter and four meters above ground to find the maximum value of the field strength for both horizontal polarization and vertical polarization of the antenna.
5. For each suspected emission, the EUT was arranged to its worst case and then tune the antenna tower (from 1 m to 4 m) and turntable (from 0 degree to 360 degrees) to find the maximum reading.
6. Set the test-receiver system to Peak Detect Function and specified bandwidth with Maximum Hold Mode.
7. If the emission level of the EUT in peak mode was 3 dB lower than the limit specified, then testing will be stopped and peak values of EUT will be reported, otherwise, the emissions will be repeated one by one using the quasi-peak method and reported
8. Emission level (dBuV/m) = 20 log Emission level (uV/m)
9. Corrected Reading: Antenna Factor + Cable Loss + Read Level - Preamp Factor = Level

3.2.4. Test Setup of Radiated Emission

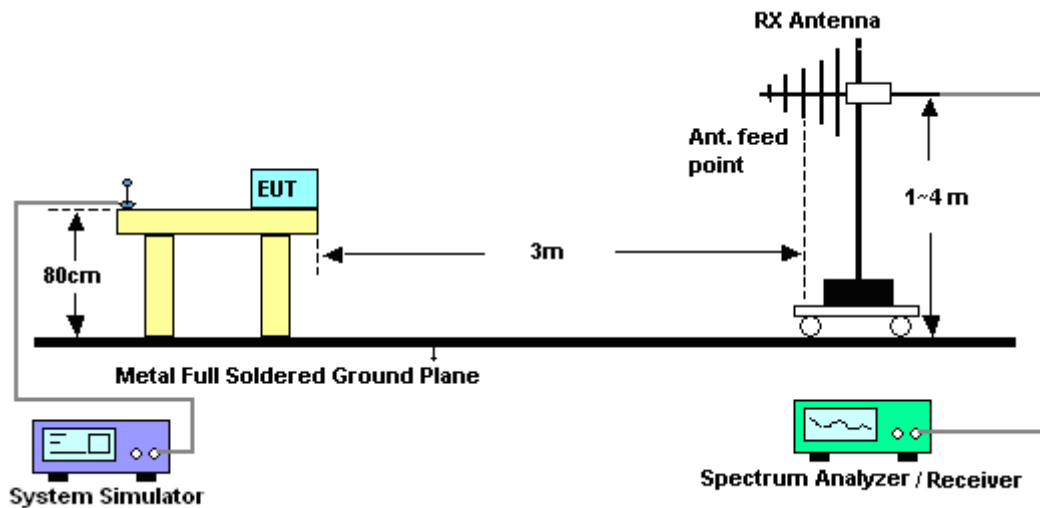



3.2.5. Test Result of Radiated Emission

Test Mode :	Mode 2	Temperature :	23~24°C
Test Engineer :	Kai Wang	Relative Humidity :	45~46%
Test Distance :	3m	Polarization :	Horizontal
Function Type :	GSM1900 Idle + Bluetooth Idle + WLAN Idle + Adapter + Earphone + Camera + Battery		

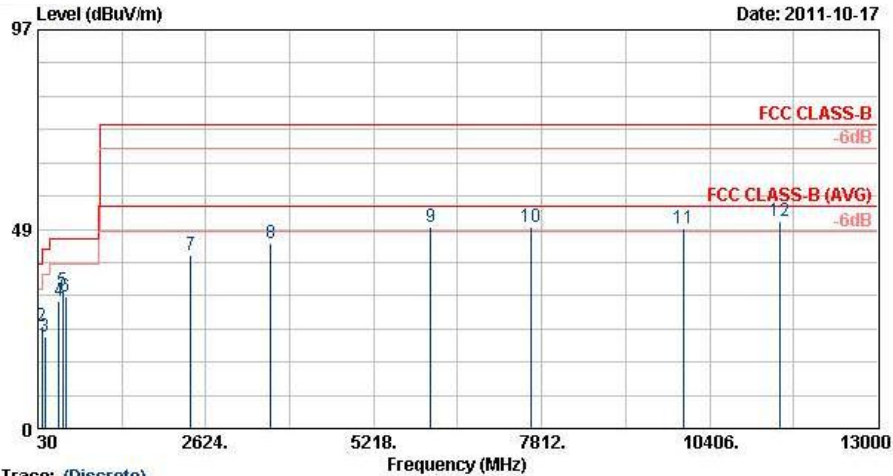

Trace: (Discrete)
 Site : 03CH06-RY
 Condition : FCC CLASS-B HF-ANT_090824 HORIZONTAL
 Power : 120Vac/60Hz
 Project : FD 100527
 Mode : Mode 2

	Freq	Level	Over	Limit	Read	Antenna	Cable	Preamp	Ant	Table	Remark
	MHz	dBuV/m	Limit	Line	Level	Factor	Loss	Factor	Pos	Pos	
			dB	dBuV/m	dBuV	dB/m	dB	dB	cm	deg	
1	30.00	20.92	-19.08	40.00	34.01	17.91	0.72	31.72	---	---	Peak
2	92.64	24.77	-18.73	43.50	45.76	9.56	1.16	31.71	---	---	Peak
3	137.19	22.34	-21.16	43.50	41.13	11.47	1.43	31.70	---	---	Peak
4	358.80	30.88	-15.12	46.00	45.36	14.82	2.26	31.56	---	---	Peak
5 @	407.80	33.43	-12.57	46.00	46.89	15.92	2.42	31.81	100	159	Peak
6	455.40	32.07	-13.93	46.00	44.48	16.91	2.52	31.85	---	---	Peak
7	2396.00	42.08	-31.92	74.00	59.10	32.48	5.40	54.90	---	---	Peak
8	3622.00	45.12	-28.88	74.00	60.25	33.50	6.85	55.49	---	---	Peak
9	6092.00	49.12	-24.88	74.00	61.21	35.94	9.29	57.32	---	---	Peak
10	7654.00	49.17	-24.83	74.00	58.71	36.13	11.14	56.81	---	---	Peak
11	9996.00	48.54	-25.46	74.00	57.72	37.30	10.42	56.90	---	---	Peak
12	11484.00	50.31	-23.69	74.00	57.13	38.10	10.80	55.72	100	0	Peak



Test Mode :	Mode 2	Temperature :	23~24°C
Test Engineer :	Kai Wang	Relative Humidity :	45~46%
Test Distance :	3m	Polarization :	Vertical
Function Type :	GSM1900 Idle + Bluetooth Idle + WLAN Idle + Adapter + Earphone + Camera + Battery		

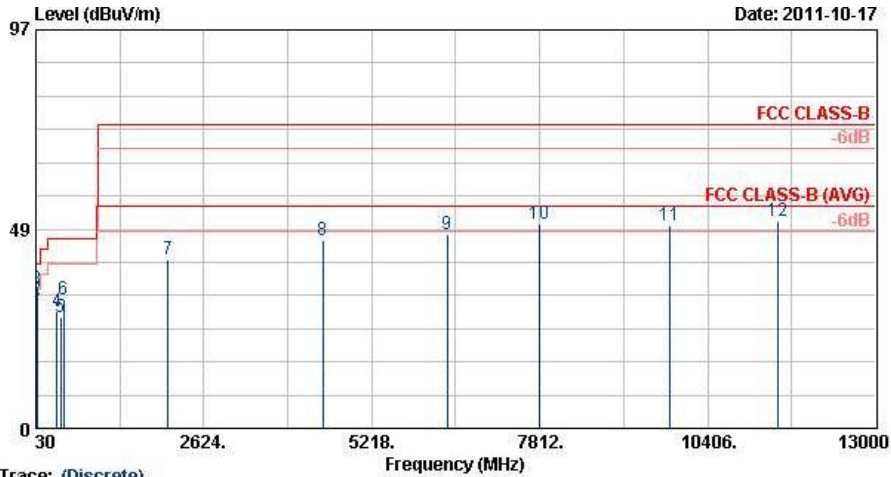

Trace: (Discrete)

Site : 03CH06-HY
 Condition : FCC CLASS-B HF-ANT_090824 VERTICAL
 Power : 120Vac/60Hz
 Project : FD_100527
 Mode : Mode 2

	Freq	Level	Over	Limit	Read	Antenna	Cable	Preamp	Ant	Table	Remark
	MHz	dBuV/m	Limit	Line	Level	Factor	Loss	Factor	Pos	Pos	
			dB	dBuV/m	dBuV	dB/m	dB	dB	cm	deg	
1 @	30.00	32.00	-8.00	40.00	45.09	17.91	0.72	31.72	---	---	Peak
2 @	36.48	31.42	-8.58	40.00	48.25	14.10	0.77	31.70	---	---	Peak
3 @	51.33	33.96	-6.04	40.00	56.87	7.92	0.87	31.70	100	129	Peak
4	358.80	28.47	-17.53	46.00	42.95	14.82	2.26	31.56	---	---	Peak
5	407.80	26.91	-19.09	46.00	40.37	15.92	2.42	31.81	---	---	Peak
6	455.40	31.50	-14.50	46.00	43.91	16.91	2.52	31.85	---	---	Peak
7	2070.00	41.21	-32.79	74.00	58.92	32.08	5.02	54.81	---	---	Peak
8	4460.00	45.77	-28.23	74.00	59.41	34.83	7.72	56.19	---	---	Peak
9	6382.00	47.11	-26.89	74.00	58.48	36.05	9.75	57.18	---	---	Peak
10	7798.00	49.69	-24.31	74.00	59.38	36.16	10.88	56.73	---	---	Peak
11	9820.00	49.25	-24.75	74.00	58.60	37.13	10.37	56.86	---	---	Peak
12	11486.00	50.54	-23.46	74.00	57.36	38.10	10.80	55.72	100	0	Peak



Test Mode :	Mode 3	Temperature :	23~24°C
Test Engineer :	Kai Wang	Relative Humidity :	45~46%
Test Distance :	3m	Polarization :	Horizontal
Function Type :	GSM850 Idle + Bluetooth Idle + WLAN Idle + GPS Rx + Earphone + Battery + USB Cable (Data Link with Notebook)		
Remark :	#7 is System Simulator Signal which can be ignored.		

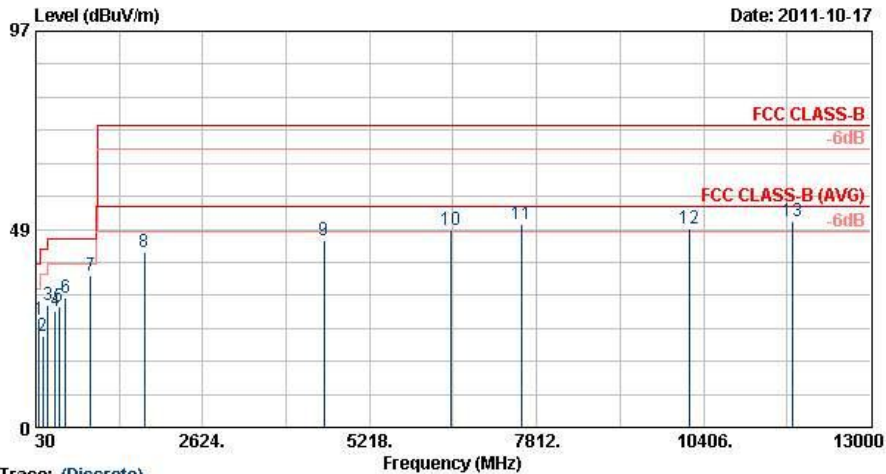

Site :
Condition :
Power :
Project :
Mode :

Trace: (Discrete)
: 03CH06-HV
: FCC CLASS-B HF-ANT_090824 HORIZONTAL
: From System
: FD 100527
: Mode 3

	Freq	Level	Over	Limit	Read	Antenna	Cable	Preamp	Ant	Table	Remark
	MHz	dBuV/m	dB	dBuV/m	dBuV	dB/m	dB	dB	cm	deg	
1	78.33	26.31	-13.69	40.00	50.05	6.89	1.08	31.70	100	142	Peak
2	136.38	22.40	-21.10	43.50	41.16	11.51	1.43	31.70	---	---	Peak
3	216.03	29.93	-16.07	46.00	49.43	10.44	1.72	31.66	---	---	Peak
4	330.80	28.34	-17.66	46.00	43.59	14.17	2.16	31.59	---	---	Peak
5	390.30	29.54	-16.46	46.00	43.40	15.54	2.37	31.77	---	---	Peak
6	497.40	31.61	-14.39	46.00	42.96	17.77	2.66	31.78	---	---	Peak
7	880.30	37.20			43.79	21.46	3.68	31.72	---	---	Peak
8	1718.00	42.80	-31.20	74.00	63.18	29.85	4.47	54.69	---	---	Peak
9	4508.00	45.75	-28.25	74.00	59.31	34.90	7.76	56.22	---	---	Peak
10	6486.00	48.26	-25.74	74.00	59.34	36.09	9.95	57.13	---	---	Peak
11	7582.00	49.93	-24.07	74.00	59.39	36.12	11.26	56.84	---	---	Peak
12	10178.00	48.85	-25.15	74.00	57.62	37.52	10.44	56.74	---	---	Peak
13	11782.00	50.45	-23.55	74.00	55.78	38.54	10.96	54.82	100	0	Peak



Test Mode :	Mode 3	Temperature :	23~24°C
Test Engineer :	Kai Wang	Relative Humidity :	45~46%
Test Distance :	3m	Polarization :	Vertical
Function Type :	GSM850 Idle + Bluetooth Idle + WLAN Idle + GPS Rx + Earphone + Battery + USB Cable (Data Link with Notebook)		
Remark :	#7 is System Simulator Signal which can be ignored.		

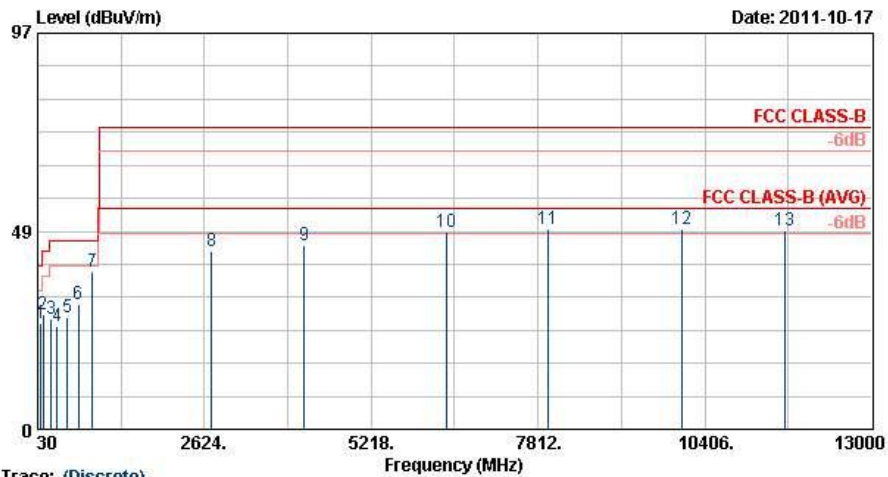

Trace: (Discrete)
 Site : 03CH06-HV
 Condition : FCC CLASS-B HF-ANT_090824 VERTICAL
 Power : From System
 Project : FD 100527
 Mode : Mode 3

	Freq	Level	Over	Limit	ReadAntenna	Cable	Preamp	Ant	Table	Remark
	MHz	dBuV/m	dB	dBuV/m	dBuV	dB/m	dB	cm	deg	
1	78.33	25.86	-14.14	40.00	49.59	6.89	1.08	31.70	100	39 Peak
2	119.64	28.23	-15.27	43.50	46.46	12.16	1.33	31.71	---	---
3	244.38	26.97	-19.03	46.00	44.51	12.29	1.83	31.66	---	---
4	336.40	25.24	-20.76	46.00	40.33	14.31	2.18	31.58	---	---
5	495.30	27.33	-18.67	46.00	38.72	17.73	2.65	31.78	---	---
6	665.40	30.56	-15.44	46.00	40.11	19.31	3.12	31.98	---	---
7 @	880.30	38.54			45.12	21.46	3.68	31.72	---	---
8	2732.00	43.62	-30.38	74.00	59.93	32.93	5.79	55.02	---	---
9	4172.00	45.20	-28.80	74.00	59.40	34.20	7.49	55.89	---	---
10	6388.00	48.27	-25.73	74.00	59.64	36.05	9.75	57.18	---	---
11	7964.00	49.20	-24.80	74.00	59.07	36.19	10.58	56.65	100	0 Peak
12	10052.00	48.89	-25.11	74.00	57.96	37.36	10.43	56.86	---	---
13	11654.00	48.70	-25.30	74.00	54.68	38.35	10.88	55.21	---	---



4. List of Measuring Equipment

Instrument	Manufacturer	Model No.	Serial No.	Characteristics	Calibration Date	Due Date	Remark
EMI Test Receive	R&S	ESCI 7	100724	9kHz~7GHz	Aug. 22, 2011	Aug. 21, 2012	Conduction (CO05-HY)
Two-LISN	R&S	ENV216	11-100081	9KHz – 30MHz	Dec. 03, 2010	Dec. 02, 2011	Conduction (CO05-HY)
Two-LISN	R&S	ENV216	11-100080	9KHz – 30MHz	Dec. 01, 2010	Nov. 30, 2011	Conduction (CO05-HY)
AC Power Source	APC	APC-1000W	N/A	N/A	N/A	N/A	Conduction (CO05-HY)
Spectrum Analyzer	R&S	FSP40	100057	9KHz-40GHz	Oct. 25, 2010	Oct. 24, 2011	Radiation (03CH06-HY)
EMI Test Receiver	R&S	ESVS10	834468/003	20MHz-1000M Hz	May 10, 2011	May 09, 2012	Radiation (03CH06-HY)
Bilog Antenna	SCHAFFNER	CBL6112B	2885	30MHz -2GHz	Oct. 31, 2010	Oct. 30, 2011	Radiation (03CH06-HY)
Double Ridge Horn Antenna	EMCO	3117	00066583	1GHz~18GHz	Aug. 01, 2011	Jul. 31, 2012	Radiation (03CH06-HY)
Pre Amplifier	Agilent	8449B	3008A01917	1GHz- 26.5GHz	Apr. 14, 2011	Apr. 13, 2012	Radiation (03CH06-HY)
Amplifier	Agilent	310N	186713	9KHz~1GHz	Apr. 14, 2011	Apr. 13, 2012	Radiation (03CH06-HY)
System Simulator	R&S	CMU200	112403	N/A	Feb. 22, 2011	Feb. 21, 2012	-

5. Uncertainty of Evaluation

Uncertainty of Conducted Emission Measurement (150 kHz ~ 30 MHz)

Contribution	Uncertainty of X_i		$u(X_i)$
	dB	Probability Distribution	
Receiver Reading	0.10	Normal (k=2)	0.05
Cable Loss	0.10	Normal (k=2)	0.05
AMN Insertion Loss	2.50	Rectangular	0.63
Receiver Specification	1.50	Rectangular	0.43
Site Imperfection	1.39	Rectangular	0.80
Mismatch	+0.34 / -0.35	U-Shape	0.24
Combined Standard Uncertainty $Uc(y)$	1.13		
Measuring Uncertainty for a Level of Confidence of 95% ($U = 2Uc(y)$)	2.26		

Uncertainty of Radiated Emission Measurement (30 MHz ~ 1000 MHz)

Contribution	Uncertainty of X_i		$u(X_i)$
	dB	Probability Distribution	
Receiver Reading	0.41	Normal (k=2)	0.21
Antenna Factor Calibration	0.83	Normal (k=2)	0.42
Cable Loss Calibration	0.25	Normal (k=2)	0.13
Pre-Amplifier Gain Calibration	0.27	Normal (k=2)	0.14
RCV/SPA Specification	2.50	Rectangular	0.72
Antenna Factor Interpolation for Frequency	1.00	Rectangular	0.29
Site Imperfection	1.43	Rectangular	0.83
Mismatch	+0.39 / -0.41	U-Shape	0.28
Combined Standard Uncertainty $Uc(y)$	1.27		
Measuring Uncertainty for a Level of Confidence of 95% ($U = 2Uc(y)$)	2.54		

Uncertainty of Radiated Emission Measurement (1 GHz ~ 40 GHz)

Contribution	Uncertainty of X_i		$u(X_i)$	C_i	$C_i * u(X_i)$
	dB	Probability Distribution			
Receiver Reading	± 0.10	Normal (k=2)	0.10	1	0.10
Antenna Factor Calibration	± 1.70	Normal (k=2)	0.85	1	0.85
Cable Loss Calibration	± 0.50	Normal (k=2)	0.25	1	0.25
Receiver Correction	± 2.00	Rectangular	1.15	1	1.15
Antenna Factor Directional	± 1.50	Rectangular	0.87	1	0.87
Site Imperfection	± 2.80	Triangular	1.14	1	1.14
Mismatch Receiver VSWR $\Gamma_1 = 0.197$ Antenna VSWR $\Gamma_2 = 0.194$ Uncertainty = $20\text{Log}(1-\Gamma_1*\Gamma_2)$	+0.34 / -0.35	U-Shape	0.244	1	0.244
Combined Standard Uncertainty $U_c(y)$	2.36				
Measuring Uncertainty for a Level of Confidence of 95% ($U = 2U_c(y)$)	4.72				