



SAR EVALUATION REPORT

Applicant Name:
 Motorola Mobility, Inc.
 8000 W. Sunrise Blvd.
 Plantation, FL 33322 USA
 USA

Date of Testing:
 11/16/11
Test Site/Location:
 PCTEST Lab, Columbia, MD, USA
Test Report Serial No.:
 OY1111161998.IHD

FCC ID:	IHDP56MJ2
APPLICANT:	MOTOROLA MOBILITY, INC.

EUT Type: Portable Tablet Computer
Application Type: Certification (5 GHz Only)
FCC Rule Part(s): CFR §2.1093

Test Device Serial No.: Pre-Production [S/N: TA3020010B]

Band & Mode	Tx Frequency	Conducted Power [dBm]	SAR
			1 gm Body (W/kg)
5.8 GHz WLAN	5745 - 5825 MHz	15.93	0.65
5.2 GHz WLAN	5180 - 5240 MHz	16.35	0.41

Note: Powers in the above table represent output powers for the SAR test configurations and may not represent the highest output powers for all modes.

I attest to the accuracy of data. All measurements reported herein were performed by me or were made under my supervision and are correct to the best of my knowledge and belief. I assume full responsibility for the completeness of these measurements and vouch for the qualifications of all persons taking them. Test results reported herein relate only to the item(s) tested.

 Randy Ortanez
 President







FCC ID: IHDP56MJ2		SAR EVALUATION REPORT		Reviewed by: Quality Manager
Filename: OY1111161998.IHD	Test Dates: 11/16/11	EUT Type: Portable Tablet Computer	Page 1 of 22	

TABLE OF CONTENTS

1	INTRODUCTION.....	3
2	TEST SITE LOCATION.....	4
3	SAR MEASUREMENT SETUP.....	5
4	DASY E-FIELD PROBE SYSTEM	8
5	PHANTOM AND EQUIVALENT TISSUES	9
6	DOSIMETRIC ASSESSMENT	10
7	FCC RF EXPOSURE LIMITS	5
8	ANTENNA LOCATIONS AND INFO	11
9	SAR TESTING WITH IEEE 802.11 TRANSMITTERS.....	13
10	RF OUTPUT POWERS.....	14
11	SYSTEM VERIFICATION	15
12	SAR DATA SUMMARY	17
13	EQUIPMENT LIST	18
14	MEASUREMENT UNCERTAINTIES	19
15	CONCLUSION	20
16	REFERENCES.....	21

FCC ID: IHDP56MJ2		SAR EVALUATION REPORT		Reviewed by: Quality Manager
Filename: 0Y1111161998.IHD	Test Dates: 11/16/11	EUT Type: Portable Tablet Computer	Page 2 of 22	

1 INTRODUCTION

The FCC has adopted the guidelines for evaluating the environmental effects of radio frequency (RF) radiation in ET Docket 93-62 on Aug. 6, 1996 to protect the public and workers from the potential hazards of RF emissions due to FCC-regulated portable devices. [1]

The safety limits used for the environmental evaluation measurements are based on the criteria published by the American National Standards Institute (ANSI) for localized specific absorption rate (SAR) in IEEE/ANSI C95.1-1992 Standard for Safety Levels with Respect to Human Exposure to Radio Frequency Electromagnetic Fields, 3 kHz to 300 GHz [3] and Health Canada RF Exposure Guidelines Safety Code 6 [24]. The measurement procedure described in IEEE/ANSI C95.3-2002 Recommended Practice for the Measurement of Potentially Hazardous Electromagnetic Fields - RF and Microwave [4] is used for guidance in measuring the Specific Absorption Rate (SAR) due to the RF radiation exposure from the Equipment Under Test (EUT). These criteria for SAR evaluation are similar to those recommended by the International Committee for Non-Ionizing Radiation Protection (ICNIRP) in "Biological Effects and Exposure Criteria for Radiofrequency Electromagnetic Fields," Report No. Vol 74. SAR is a measure of the rate of energy absorption due to exposure to an RF transmitting source. SAR values have been related to threshold levels for potential biological hazards.

1.1 SAR Definition

Specific Absorption Rate is defined as the time derivative (rate) of the incremental energy (dU) absorbed by (dissipated in) an incremental mass (dm) contained in a volume element (dV) of a given density (ρ). It is also defined as the rate of RF energy absorption per unit mass at a point in an absorbing body (see Fig. 1-1).

$$SAR = \frac{d}{dt} \left(\frac{dU}{dm} \right) = \frac{d}{dt} \left(\frac{dU}{\rho dv} \right)$$

Figure 1-1
SAR Mathematical Equation



SAR is expressed in units of Watts per Kilogram (W/kg).

$$SAR = \frac{\sigma \cdot E^2}{\rho}$$

where:

- σ = conductivity of the tissue-simulating material (S/m)
- ρ = mass density of the tissue-simulating material (kg/m^3)
- E = Total RMS electric field strength (V/m)

NOTE: The primary factors that control rate of energy absorption were found to be the wavelength of the incident field in relation to the dimensions and geometry of the irradiated organism, the orientation of the organism in relation to the polarity of field vectors, the presence of reflecting surfaces, and whether conductive contact is made by the organism with a ground plane.[6]

FCC ID: IHDP56MJ2		SAR EVALUATION REPORT		Reviewed by: Quality Manager
Filename: 0Y1111161998.IHD	Test Dates: 11/16/11	EUT Type: Portable Tablet Computer		Page 3 of 22

2 TEST SITE LOCATION

2.1 INTRODUCTION

The map at the right shows the location of the PCTEST LABORATORY in Columbia, Maryland. It is in proximity to the FCC Laboratory, the Baltimore-Washington International (BWI) airport, the city of Baltimore and Washington, DC.

These measurement tests were conducted at the PCTEST Engineering Laboratory, Inc. facility in New Concept Business Park, Guilford Industrial Park, Columbia, Maryland. The site address is 6660-B Dobbin Road, Columbia, MD 21045. The test site is one of the highest points in the Columbia area with an elevation of 390 feet above mean sea level. The site coordinates are 39° 11'15" N latitude and 76° 49' 38" W longitude. The facility is 1.5 miles north of the FCC laboratory, and the ambient signal and ambient signal strength are approximately equal to those of the FCC laboratory. There are no FM or TV transmitters within 15 miles of the site. The detailed description of the measurement facility was found to be in compliance with the requirements of § 2.948 according to ANSI C63.4 on January 27, 2006 and Industry Canada.

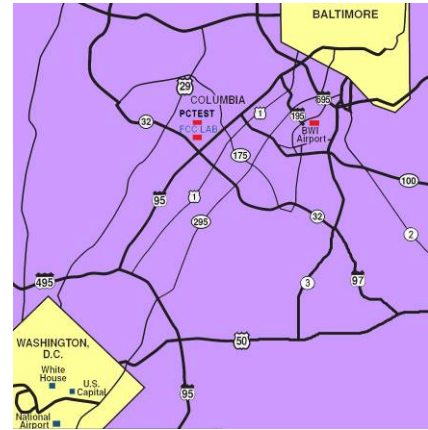
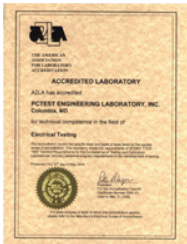

Figure 2-1

Map of the Greater Baltimore and Metropolitan Washington, D.C. area

2.2 Test Facility / Accreditations:

Measurements were performed at an independent accredited PCTEST Engineering Lab located in Columbia, MD 21045, U.S.A.



- PCTEST Lab is accredited to ISO 17025-2005 by the American Association for Laboratory Accreditation (A2LA) in Specific Absorption Rate (SAR) testing, Hearing-Aid Compatibility (HAC), Battery Safety, CTIA Test Plans, and wireless testing for FCC and Industry Canada Rules.
- PCTEST Lab is accredited to ISO 17025 by U.S. National Institute of Standards and Technology (NIST) under the National Voluntary Laboratory Accreditation Program (NVLAP Lab code: 100431-0) in EMC, FCC and Telecommunications.
- PCTEST facility is an FCC registered (PCTEST Reg. No. 90864) test facility with the site description report on file and has met all the requirements specified in Section 2.948 of the FCC Rules and Industry Canada (IC-2451).
- PCTEST Lab is a recognized U.S. Conformity Assessment Body (CAB) in EMC and R&TTE (n.b. 0982) under the U.S.-EU Mutual Recognition Agreement (MRA).
- PCTEST TCB is a Telecommunication Certification Body (TCB) accredited to ISO/IEC Guide 65 by the American National Standards Institute (ANSI) in all scopes of FCC Rules and all Industry Canada Standards (RSS).
- PCTEST facility is an IC registered (IC-2451) test laboratory with the site description on file at Industry Canada.
- PCTEST is a CTIA Authorized Test Laboratory (CATL) for AMPS and CDMA, and EvDO mobile phones.
- PCTEST is a CTIA Authorized Test Laboratory (CATL) for Over-the-Air (OTA) Antenna Performance testing for AMPS, CDMA, GSM, GPRS, EGPRS, UMTS (W-CDMA), CDMA 1xEVDO Data, CDMA 1xRTT Data

FCC ID: IHDP56MJ2	PCTEST ENGINEERING LABORATORY, INC.	SAR EVALUATION REPORT	MOTOROLA	Reviewed by: Quality Manager
Filename: 0Y1111161998.IHD	Test Dates: 11/16/11	EUT Type: Portable Tablet Computer		Page 4 of 22

3 FCC RF EXPOSURE LIMITS

3.1 Uncontrolled Environment

UNCONTROLLED ENVIRONMENTS are defined as locations where there is the exposure of individuals who have no knowledge or control of their exposure. The general population/uncontrolled exposure limits are applicable to situations in which the general public may be exposed or in which persons who are exposed as a consequence of their employment may not be made fully aware of the potential for exposure or cannot exercise control over their exposure. Members of the general public would come under this category when exposure is not employment-related; for example, in the case of a wireless transmitter that exposes persons in its vicinity.



3.2 Controlled Environment

CONTROLLED ENVIRONMENTS are defined as locations where there is exposure that may be incurred by persons who are aware of the potential for exposure, (i.e. as a result of employment or occupation). In general, occupational/controlled exposure limits are applicable to situations in which persons are exposed as a consequence of their employment, who have been made fully aware of the potential for exposure and can exercise control over their exposure. This exposure category is also applicable when the exposure is of a transient nature due to incidental passage through a location where the exposure levels may be higher than the general population/uncontrolled limits, but the exposed person is fully aware of the potential for exposure and can exercise control over his or her exposure by leaving the area or by some other appropriate means.

Table 3-1
SAR Human Exposure Specified in ANSI/IEEE C95.1-1992 and Health Canada Safety Code 6

HUMAN EXPOSURE LIMITS		
	UNCONTROLLED ENVIRONMENT <i>General Population</i> (W/kg) or (mW/g)	CONTROLLED ENVIRONMENT <i>Occupational</i> (W/kg) or (mW/g)
SPATIAL PEAK SAR Brain	1.6	8.0
SPATIAL AVERAGE SAR Whole Body	0.08	0.4
SPATIAL PEAK SAR Hands, Feet, Ankles, Wrists	4.0	20

1. The Spatial Peak value of the SAR averaged over any 1 gram of tissue (defined as a tissue volume in the shape of a cube) and over the appropriate averaging time.
2. The Spatial Average value of the SAR averaged over the whole body.
3. The Spatial Peak value of the SAR averaged over any 10 grams of tissue (defined as a tissue volume in the shape of a cube) and over the appropriate averaging time.

FCC ID: IHDP56MJ2	 PCTEST ENGINEERING LABORATORY, INC.	SAR EVALUATION REPORT		Reviewed by: Quality Manager
Filename: 0Y1111161998.IHD	Test Dates: 11/16/11	EUT Type: Portable Tablet Computer		Page 5 of 22

4 SAR MEASUREMENT SETUP

4.1 Robotic System

Measurements are performed using the DASY4 automated dosimetric assessment system. The DASY4 is made by Schmid & Partner Engineering AG (SPEAG) in Zurich, Switzerland and consists of a high precision robotics system (Staubli), robot controller, desktop computer, near-field probe, probe alignment sensor, and the SAM phantom containing the head or body equivalent material. The robot is a six-axis industrial robot, performing precise movements to position the probe to the location (points) of maximum electromagnetic field (EMF) (see Figure 3-1).

4.2 System Hardware

A cell controller system contains the power supply, robot controller, teach pendant (Joystick), and a remote control used to drive the robot motors. The PC consists of the SAR Measurement Software DASY4, A/D interface card, monitor, mouse, and keyboard. The Staubli Robot is connected to the cell controller to allow software manipulation of the robot. A data acquisition electronic (DAE) circuit that performs the signal amplification, signal multiplexing, A/D conversion, offset measurements, mechanical surface detection, collision detection, etc. is connected to the Electro-optical coupler (EOC). The EOC performs the conversion from the optical into digital electric signal from the DAE and transfers data to the PC card.

4.3 System Electronics

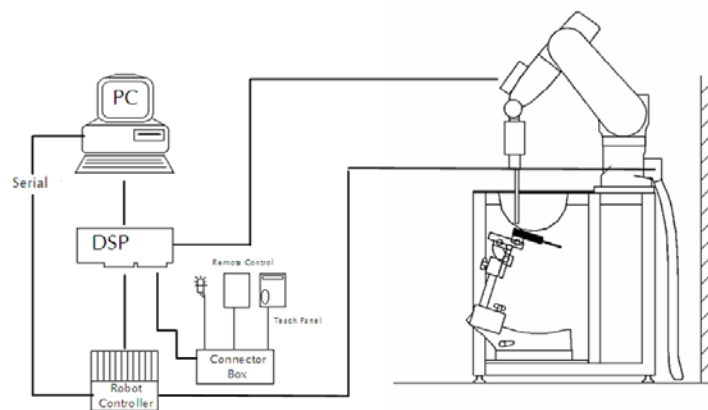



Figure 4-1
SAR Measurement System Setup

The DAE consists of a highly sensitive electrometer-grade auto-zeroing preamplifier, a channel and gain-switching multiplexer, a fast 16 bit AD-converter and a command decoder and control logic unit. Transmission to the PC-card is accomplished through an optical downlink for data and status information and an optical uplink for commands and clock lines. The mechanical probe mounting device includes two different sensor systems for frontal and sidewise probe contacts. They are also used for mechanical surface detection and probe collision detection. The robot uses its own controller with a built in VME-bus computer.

FCC ID: IHDP56MJ2		SAR EVALUATION REPORT		Reviewed by: Quality Manager
Filename: 0Y1111161998.IHD	Test Dates: 11/16/11	EUT Type: Portable Tablet Computer		Page 6 of 22

4.4 Automated Test System Specifications

Test Software: SPEAG DASY4 version 4.7 Measurement Software
Robot: Stäubli Unimation Corp. Robot RX60L
Repeatability: 0.02 mm
No. of Axes: 6

Data Acquisition Electronic System (DAE)

Data Converter

Features: Signal Amplifier, multiplexer, A/D converter & control logic
Software: SEMCAD software
Connecting Lines: Optical Downlink for data and status info
Optical upload for commands and clock

PC Interface Card



Function: Link to DAE
16-bit A/D converter for surface detection system
Two Serial & Ethernet link to robotics
Direct emergency stop output for robot

Phantom

Type: SAM Twin Phantom (V4.0)
Shell Material: Composite
Thickness: 2.0 ± 0.2 mm



Figure 4-2
SAR Measurement System

FCC ID: IHDP56MJ2		SAR EVALUATION REPORT		Reviewed by: Quality Manager
Filename: 0Y1111161998.IHD	Test Dates: 11/16/11	EUT Type: Portable Tablet Computer		Page 7 of 22

5.1 Probe Measurement System



**Figure 5-1
SAR System**

The SAR measurements were conducted with the dosimetric probe designed in the classical triangular configuration (see Figure 4-3) and optimized for dosimetric evaluation [9]. The probe is constructed using the thick film technique; with printed resistive lines on ceramic substrates. The probe is equipped with an optical multi-fiber line ending at the front of the probe tip. It is connected to the EOC box on the robot arm and provides an automatic detection of the phantom surface. Half of the fibers are connected to a pulsed infrared transmitter, the other half to a synchronized receiver. As the probe approaches the surface, the reflection from the surface produces a coupling from the transmitting to the receiving fibers. This reflection increases first during the approach, reaches maximum and then decreases. If the probe is flatly touching the surface, the coupling is zero. The distance of the coupling maximum to the surface is independent of the surface reflectivity and largely independent of the surface to probe angle. The DASY4 software reads the reflection during a software approach and looks for the

maximum using a 2nd order curve fitting (see Figure 5-1). The approach is stopped at reaching the maximum.

5.2 Probe Specifications



Model(s):	ES3DV2, ES3DV3, EX3DV4
Frequency Range:	10 MHz – 6.0 GHz (EX3DV4) 10 MHz – 4 GHz (ES3DV3)
Calibration:	In head and body simulating tissue at Frequencies from 300 up to 6000MHz
Linearity:	± 0.2 dB (30 MHz to 6 GHz) for EX3DV4 ± 0.2 dB (30 MHz to 4 GHz) for ES3DV3
Dynamic Range:	10 mW/kg – 100 W/kg
Probe Length:	330 mm
Probe Tip Length:	20 mm
Body Diameter:	12 mm
Tip Diameter:	2.5 mm (3.9mm for ES3DV3)
Tip-Center:	1 mm (2.0 mm for ES3DV3)
Application:	SAR Dosimetry Testing Compliance tests of mobile phones Dosimetry in strong gradient fields



**Figure 5-2
Near-Field Probe**



**Figure 5-3
Triangular Probe
Configuration**

FCC ID: IHDP56MJ2	 PCTEST ENGINEERING LABORATORY, INC.	SAR EVALUATION REPORT		Reviewed by: Quality Manager
Filename: 0Y1111161998.IHD	Test Dates: 11/16/11	EUT Type: Portable Tablet Computer		Page 8 of 22

6 PHANTOM AND EQUIVALENT TISSUES

6.1 Specific Anthropomorphic Mannequin (SAM) Specifications

The phantom for handset SAR assessment testing is a low-loss dielectric shell, with shape and dimensions derived from the anthropometric data of the 90th percentile adult male head dimensions as tabulated by the US Army. The SAM Twin Phantom shell is bisected along the mid-sagittal plane into right and left halves (see Figure 5-1). The perimeter sidewalls of each phantom halves are extended to allow filling with liquid to a depth that is sufficient to minimize reflections from the upper surface. The liquid depth is maintained at a minimum depth of 15 cm.



Figure 6-1
SAM Twin Phantom Shell

6.2 Tissue Simulating Mixture Characterization



Figure 6-2
SAM Phantom with Simulating Tissue



The mixture is characterized to obtain proper dielectric constant (permittivity) and conductivity of the tissue of interest. The tissue dielectric parameters recommended in IEEE 1528 and IEC 62209 have been used as targets for the compositions, and are to match within 5%, per the FCC recommendations.

Table 6-1
Composition of the Tissue Equivalent Matter

Frequency (MHz)	5200-5800
Tissue	Body
Ingredients (% by weight)	
Triton X-100	10.67
Diethylenglycol monohexylether	10.67
Water	78.66

6.3 Device Holder

The DASy device holder has been made out of low-loss POM material having the following dielectric parameters: relative permittivity $\epsilon = 3$ and loss tangent $\delta = 0.02$.

FCC ID: IHDP56MJ2		SAR EVALUATION REPORT		Reviewed by: Quality Manager
Filename: 0Y1111161998.IHD	Test Dates: 11/16/11	EUT Type: Portable Tablet Computer		Page 9 of 22

7 DOSIMETRIC ASSESSMENT

7.1 Measurement Procedure

The evaluation was performed using the following procedure:

1. The SAR distribution area was ensured to cover the entire dimension of the body phantom area with the DUT positioned against the phantom. The horizontal grid resolution was 10mm x 10mm (for 5-6 GHz frequencies per KDB 865664 pub).
2. The point SAR measurement was taken at the maximum SAR region determined from Step 1 to enable the monitoring of SAR fluctuations/drifts during testing the 1 gram cube. This fixed point was measured and used as a reference value.
3. Based on the area scan data, the area of the maximum absorption was determined by spline interpolation. Around this point, a fine resolution volume scan, "zoom scan," was assessed. On this basis of this data set, the spatial peak SAR value was evaluated with the following procedure (see references or the DASY manual for more details):
 - a. The data was extrapolated to the surface of the outer-shell of the phantom. The combined distance extrapolated was the combined distance from the center of the diodes from the tip of the probe housing plus the distance between the phantom outer surface and the lowest measuring point. The extrapolation was based on a least-squares algorithm. A polynomial of the fourth order was calculated through the points in the z-axis (normal to the phantom shell).
 - b. After the maximum interpolated values were calculated between the points in the cube, the SAR was averaged over the spatial volume (1g or 10g) using a 3D-Spline interpolation algorithm. The 3D-spline is composed of three one-dimensional splines with the "Not a knot" condition (in x, y, and z directions). The volume was then integrated with the trapezoidal algorithm. One thousand points were obtained through interpolation, in order to calculate the averaged SAR.
 - c. All neighboring volumes were evaluated until no neighboring volume with a higher average value was found.
4. The SAR reference value, at the same location as step 2, was re-measured after the zoom scan was complete. If the value deviated by more than 5%, the evaluation was repeated.

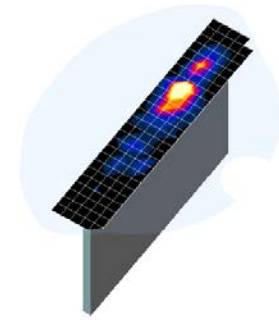



Figure 7-1
Sample SAR Area Scan

7.2 5 GHz SAR Testing Considerations per KDB 865664 publication

For 5 GHz testing, finer resolution Area scans were performed as specified by FCC SAR Measurement Requirements for 3 – 6 GHz, KDB pub 865664. The 5 GHz Area Scan requires a minimum resolution of 10mm on the x and y axis for each grid measurement point.

For 5 GHz testing finer resolution zoom scans were performed as specified by FCC SAR Measurement Requirements for 3 – 6 GHz, KDB pub 865664. The 5 GHz zoom scan requires a minimum volume of 24mm x 24mm x 20mm and 7 x 7 x 11 points.

FCC ID: IHDP56MJ2		SAR EVALUATION REPORT		Reviewed by: Quality Manager
Filename: 0Y1111161998.IHD	Test Dates: 11/16/11	EUT Type: Portable Tablet Computer		Page 10 of 22

8 WIFI ANTENNA LOCATION AND INFO

8.1 Antenna and Key Feature Information

Table 8-1 Antenna Information
Bluetooth/Wi-Fi 2.45 / 5 GHz Antenna

Type	Internal	
Location	Right Edge of Transceiver	
Dimensions	Width	3.67 mm
	Length	18.9 mm



Figure 8-1 Back View of Device

FCC ID: IHDP56MJ2	 PCTEST ENGINEERING LABORATORY, INC.	SAR EVALUATION REPORT	 MOTOROLA
Filename: OY1111161998.IHD	Test Dates: 11/16/11	EUT Type: Portable Tablet Computer	Reviewed by: Quality Manager Page 11 of 22

8.2 SAR Testing for Tablet per KDB Publication 447498 Section 4



Lap-touching devices that have transmitting antennas located less than 20 cm from the body of the user require routine SAR evaluation. Such devices are considered portable, and are capable of being held to the body. Devices are to be setup according to KDB publication 447498 requirements and are configured with maximum output power during SAR assessment for a worst-case SAR evaluation.

Per KDB 447498 4) b) i), the bottom face (back of the device) is required to be tested touching the flat phantom.

Per KDB Publication 447498 4) b) ii) (2), SAR testing applies for the tablet edges with antennas located within 5 cm of each tablet edge closest to the user (with KDB Publication 616217 applied to edges with antennas located ≥ 5 cm from the user). According to KDB Publication 447498 4) b) ii) (2), for each antenna, SAR is only required for the edge with the most conservative exposure condition. Since the diagonal dimension of the device is more than 20 cm, this device is a tablet (not a mini-tablet).

8.3 Display Orientation Capabilities

This device is capable of multiple display orientations supporting both portrait and landscape positions. Therefore per KDB 447498 4) b) ii) (2), SAR testing applies for the tablet edges with antennas located within 5 cm of each tablet edge closest to the user (with KDB 616217 applied to edges with antennas located ≥ 5 cm from the user). According to KDB 447498 4) b) ii) (2), for each antenna, SAR is only required for the edge with the most conservative exposure condition.

FCC ID: IHDP56MJ2	 PCTEST ENGINEERING LABORATORY, INC.	SAR EVALUATION REPORT		Reviewed by: Quality Manager
Filename: 0Y1111161998.IHD	Test Dates: 11/16/11	EUT Type: Portable Tablet Computer		Page 12 of 22

9 SAR TESTING WITH IEEE 802.11 TRANSMITTERS

Per KDB 248227 publication, normal network operating configurations are not suitable for measuring the SAR of 802.11 WIFI transmitters. Unpredictable fluctuations in network traffic and antenna diversity conditions can introduce undesirable variations in SAR results. The SAR for these devices should be measured using chipset based test mode software to ensure the results are consistent and reliable.

9.1 General Device Setup

Chipset based test mode software is hardware dependent and generally varies among manufacturers. The device operating parameters established in test mode for SAR measurements must be identical to those programmed in production units, including output power levels, amplifier gain settings and other RF performance tuning parameters. The test frequencies should correspond to actual channel frequencies defined for domestic use. SAR for devices with switched diversity should be measured with only one antenna transmitting at a time during each SAR measurement, according to a fixed modulation and data rate. The same data pattern should be used for all measurements.



9.2 Frequency Channel Configurations [27]

802.11 a/n operating modes are tested independently according to the service requirements in each frequency band. 802.11a/n is tested for UNII operations on channels 36 and 48 in the 5.15-5.25 GHz band, and channels 149 and 161 in the 5.8 GHz band. When 5.8 GHz §15.247 is also available, channels 149, 157 and 165 should be tested instead of the UNII channels. These are referred to as the “default test channels”. For 5 GHz, 802.11n modes were evaluated only if the output power was 0.25 dB higher than the 802.11a mode.

**Table 9-1
802.11 Test Channels per FCC Requirements**

Mode	GHz	Channel	Turbo Channel	“Default Test Channels”		
				§15.247 802.11b	802.11g	UNII
802.11 b/g	2.412	1		√	∇	
	2.437	6	6	√	∇	
	2.462	11		√	∇	
802.11a	5.18	36				√
	5.20	40	42 (5.21 GHz)			*
	5.22	44				*
	5.24	48				√
	5.26	52	50 (5.25 GHz)			√
	5.28	56	58 (5.29 GHz)			*
	5.30	60				*
	5.32	64				√
	5.500	100	Unknown			*
	5.520	104				√
	5.540	108				*
	5.560	112				*
	5.580	116				√
	5.600	120				*
	5.620	124				√
	5.640	128				*
	5.660	132				*
	5.680	136				√
	5.700	140			*	
	UNII or §15.247	5.745	149		√	√
5.765		153	152 (5.76 GHz)		*	*
5.785		157		√		*
5.805		161	160 (5.80 GHz)		*	√
§15.247	5.825	165		√		

Per FCC KDB Publication 443999 and RSS-210 A9.2(3), transmission on channels which overlap the 5600-5650 MHz is prohibited as a client.

FCC ID: IHDP56MJ2	 PCTEST ENGINEERING LABORATORY, INC.	SAR EVALUATION REPORT		Reviewed by: Quality Manager
Filename: OY1111161998.IHD	Test Dates: 11/16/11	EUT Type: Portable Tablet Computer		Page 13 of 22

10 RF OUTPUT POWERS

**Table 10-1
IEEE 802.11a/n Average RF Power**



Mode	Freq [MHz]	Channel	Conducted Power [dBm]							
			Data Rate [Mbps]							
			6	9	12	18	24	36	48	54
802.11a	5180	36	15.41	15.44	14.55	14.51	13.89	13.90	12.07	12.09
802.11a	5200	40	16.09	16.03	15.11	15.02	14.55	14.45	12.64	12.63
802.11a	5220	44	15.51	15.46	14.54	14.59	13.93	14.03	12.14	12.07
802.11a	5240	48	15.34	15.32	14.35	14.38	13.76	13.76	11.97	11.97
802.11a	5745	149	15.48	15.52	14.53	14.71	13.86	13.81	11.84	11.78
802.11a	5765	153	15.22	15.14	14.18	14.15	13.40	13.51	11.39	11.33
802.11a	5785	157	15.66	15.72	14.50	14.63	13.85	13.86	11.81	11.86
802.11a	5805	161	15.93	15.89	14.87	14.87	14.16	14.23	12.17	12.07
802.11a	5825	165	15.73	15.67	15.75	15.75	15.58	15.57	13.99	13.98

Mode	Freq [MHz]	Channel	Conducted Power [dBm] 20 MHz Channel, 400 ns Guard Interval							
			Data Rate [Mbps]							
			7.2	14.4	22	29	43	58	65	72
802.11n	5180	36	15.65	14.66	14.70	14.19	14.17	12.16	12.30	11.26
802.11n	5200	40	16.35	15.20	15.26	14.68	14.81	12.72	12.83	11.85
802.11n	5220	44	15.86	14.81	14.77	14.19	12.20	12.25	12.26	11.28
802.11n	5240	48	15.78	14.69	14.66	14.15	14.06	12.17	12.10	11.24
802.11n	5745	149	15.42	14.04	14.21	13.59	13.54	11.44	11.30	10.36
802.11n	5765	153	14.96	13.71	13.87	13.09	13.22	10.86	11.06	9.79
802.11n	5785	157	15.33	14.28	14.40	13.64	13.72	11.44	11.47	10.27
802.11n	5805	161	15.69	14.63	14.65	14.00	14.01	11.73	11.72	10.61
802.11n	5825	165	15.40	15.56	15.57	15.46	15.44	13.80	13.88	12.82

Mode	Freq [MHz]	Channel	Conducted Power - 800ns Guard Interval [dBm]							
			Data Rate [Mbps]							
			6.5	13	20	26	39	52	58	65
802.11n	5180	36	15.49	14.41	14.51	13.96	13.98	12.15	12.02	11.05
802.11n	5200	40	16.19	15.09	15.08	14.55	14.55	12.58	12.57	11.57
802.11n	5220	44	15.56	14.51	14.53	14.04	14.02	12.11	12.19	11.16
802.11n	5240	48	15.49	14.45	14.35	13.79	13.88	11.88	11.93	10.92
802.11n	5745	149	15.25	14.18	14.29	13.75	13.64	11.58	11.38	10.28
802.11n	5765	153	14.94	13.83	13.77	13.30	13.34	11.10	11.11	9.85
802.11n	5785	157	15.54	14.24	14.35	13.66	13.82	11.53	11.70	10.45
802.11n	5805	161	15.87	14.59	14.67	14.04	14.03	11.82	11.86	10.73
802.11n	5825	165	15.60	15.56	15.61	15.53	15.59	13.88	13.98	12.89

Justification for reduced test configurations for WIFI channels per KDB Publication 248227 and April 2010 FCC/TCB Meeting Notes:

- Justification for reduced test configurations for WIFI channels per KDB Publication 248227 and April 2010 FCC/TCB Meeting Notes: Highest average RF output power channel for the lowest data rate were selected for SAR evaluation (as the default channel). Higher data rates were not investigated since the average output powers were not greater than 0.25 dB than that of the corresponding channel in the lowest data rate IEEE 802.11a modes. IEEE 802.11n was additionally tested since the average output powers were more than 0.25 dB higher than IEEE 802.11a conducted powers.
- Per FCC Publication 248227 D01 when the maximum extrapolated peak SAR of the zoom scan for the maximum output channel is >1.6 W/kg or the 1g averaged SAR is >0.8 W/kg, SAR testing was additionally performed on the corresponding default test channels or required test channel based on highest output power.
- The bolded data rates and channels above were tested for SAR.

FCC ID: IHDP56MJ2	 PCTEST ENGINEERING LABORATORY, INC.	SAR EVALUATION REPORT		Reviewed by: Quality Manager
Filename: OY1111161998.IHD	Test Dates: 11/16/11	EUT Type: Portable Tablet Computer		Page 14 of 22

11 SAR SYSTEM VERIFICATION

11.1 Tissue Verification

**Table 11-1
Measured Tissue Properties**

Calibrated for Tests Performed on:	Tissue Type	Tissue Temp During Calibration (C°)	Measured Frequency (MHz)	Measured Conductivity, σ (S/m)	Measured Dielectric Constant, ϵ	TARGET Conductivity, σ (S/m)	TARGET Dielectric Constant, ϵ	% dev σ	% dev ϵ
11/16/2011	5200B-5800B	24.8	5200	5.386	47.06	5.299	49.014	1.64%	-3.99%
			5220	5.415	47.08	5.323	48.987	1.73%	-3.89%
			5745	6.121	46.06	5.936	48.248	3.12%	-4.53%
			5800	6.199	45.93	6.000	48.200	3.32%	-4.71%
			5805	6.191	45.90	6.005	48.166	3.10%	-4.70%
			5825	6.247	45.92	6.029	48.132	3.62%	-4.60%

Note: KDB Publication 450824 was ensured to be applied for probe calibration frequencies greater than or equal to 50 MHz of the DUT frequencies.

Probe calibration used within ± 100 MHz of the test frequency in 5.725 - 5.85 is acceptable per KDB Publication 865664 since the design of the SAR probe supports the extended frequency, provided the DASY software version recommended is used for the tests, and the expanded calibration uncertainty ($k=2$) is less than or equal to 15% (See SAR probe calibration certificate for this information). The dielectric and conductivities measured are within 10% and 5% respectively of the target parameters specified in Supplement C 01-01.



The above measured tissue parameters were used in the DASY software to perform interpolation via the DASY software to determine actual dielectric parameters at the test frequencies (per IEEE 1528 6.6.1.2). The SAR test plots may slightly differ from the table above since the DASY software rounds to three significant digits.

11.2 Measurement Procedure for Tissue verification

- 1) The network analyzer and probe system was configured and calibrated.
- 2) The probe was immersed in the sample which was placed in a nonmetallic container. Trapped air bubbles beneath the flange were minimized by placing the probe at a slight angle.
- 3) The complex admittance with respect to the probe aperture was measured
- 4) The complex relative permittivity, for example from the below equation (Pournaropoulos and Misra):

$$Y = \frac{j2\omega\epsilon_r\epsilon_0}{[\ln(b/a)]^2} \int_a^b \int_a^b \int_0^\pi \cos\phi' \frac{\exp[-j\omega r(\mu_0\epsilon_r'\epsilon_0)^{1/2}]}{r} d\phi' d\rho' d\rho$$

where Y is the admittance of the probe in contact with the sample, the primed and unprimed coordinates refer to source and observation points, respectively, $r^2 = \rho^2 + \rho'^2 - 2\rho\rho' \cos\phi'$, ω is the angular frequency, and $j = \sqrt{-1}$.

FCC ID: IHDP56MJ2		SAR EVALUATION REPORT		Reviewed by: Quality Manager
Filename: 0Y1111161998.IHD	Test Dates: 11/16/11	EUT Type: Portable Tablet Computer		Page 15 of 22

11.3 Test System Verification

Prior to assessment, the system is verified to $\pm 10\%$ of the manufacturer SAR measurement on the reference dipole at the time of calibration.

**Table 11-2
System Verification Results**

System Verification TARGET & MEASURED											
Date:	Amb. Temp (°C)	Liquid Temp (°C)	Input Power (W)	Tissue Frequency (MHz)	Dipole SN	Probe SN	Tissue Type	Measured SAR _{1g} (W/kg)	1 W Target SAR _{1g} (W/kg)	1 W Normalized SAR _{1g} (W/kg)	Deviation (%)
11/16/2011	24.5	23.0	0.100	5200	1057	3561	Body	8.3	77.700	83.000	6.82%
11/16/2011	24.1	22.9	0.100	5800	1057	3561	Body	7.89	75.000	78.900	5.20%

Note: Per KDB Publication 865664, when a reference dipole is not defined within $\pm 100\text{MHz}$ of the test frequency, the system verification may be conducted within $\pm 200\text{ MHz}$ of the center frequency of the measurement frequencies if the SAR probe calibration is valid and the same tissue-equivalent matter is used for verification and test measurements.

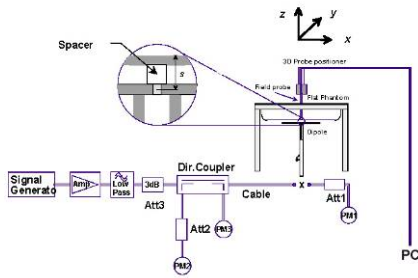

**Figure 11-1
System Verification Setup Diagram**



**Figure 11-2
System Verification Setup Photo**

FCC ID: IHDP56MJ2		SAR EVALUATION REPORT		Reviewed by: Quality Manager
Filename: OY1111161998.IHD	Test Dates: 11/16/11	EUT Type: Portable Tablet Computer		Page 16 of 22



12 DETAILED SAR TEST DATA

**Table 12-1
5 GHz Body SAR Results**

MEASUREMENT RESULTS									
FREQUENCY		Mode	Service	Conducted Power [dBm]	Power Drift [dB]	Spacing	Data Rate (Mbps)	Side	SAR (1g)
MHz	Ch.								(W/kg)
5745	149	IEEE 802.11a	OFDM	15.48	-0.17	0.0 cm	6	back	0.361
5805	161	IEEE 802.11a	OFDM	15.93	-0.17	0.0 cm	6	back	0.599
5825	165	IEEE 802.11a	OFDM	15.73	-0.16	0.0 cm	6	back	0.614
5745	149	IEEE 802.11a	OFDM	15.48	0.16	0.0 cm	6	right	0.555
5805	161	IEEE 802.11a	OFDM	15.93	0.09	0.0 cm	6	right	0.646
5825	165	IEEE 802.11a	OFDM	15.73	-0.15	0.0 cm	6	right	0.546
5200	40	IEEE 802.11a	OFDM	16.09	-0.14	0.0 cm	6	back	0.400
5220	44	IEEE 802.11a	OFDM	15.51	-0.13	0.0 cm	6	back	0.409
5200	40	IEEE 802.11n	OFDM	16.35	-0.15	0.0 cm	6.5	back	0.382
5220	44	IEEE 802.11n	OFDM	15.86	-0.13	0.0 cm	6.5	back	0.402
5200	40	IEEE 802.11a	OFDM	16.09	-1.16	0.0 cm	6	right	0.318
5220	44	IEEE 802.11a	OFDM	15.51	-1.84	0.0 cm	6	right	0.132
5200	40	IEEE 802.11n	OFDM	16.35	0.11	0.0 cm	6.5	right	0.315
5220	44	IEEE 802.11n	OFDM	15.86	0.13	0.0 cm	6.5	right	0.331
ANSI / IEEE C95.1 1992 - SAFETY LIMIT						Body			
Spatial Peak						1.6 W/kg (mW/g)			
Uncontrolled Exposure/General Population						averaged over 1 gram			



SAR Test Notes:

- The test data reported are the worst-case SAR value with the position set in a typical configuration. Test procedures used were according to FCC/OET Bulletin 65, Supplement C [June 2001].
- Per KDB Pub. 448498 4) b) i) the back side is required to be tested touching the flat phantom.
- This device is capable of multiple display orientations supporting both portrait and landscape positions. Therefore per KDB Pub. 447498 4) b) ii) (2), SAR testing applies for the tablet edges with antennas located within 5 cm of each tablet edge closest to the user (with KDB Pub. 616217 applied to edges with antennas located ≥ 5 cm from the user). According to KDB Pub. 447498 4) b) ii) (2), for each antenna, SAR is only required for the edge with the most conservative exposure condition.
- Batteries are fully charged for all readings.
- Tissue parameters and temperatures are listed on the SAR plots.
- Liquid tissue depth is was at least 15.0 cm.
- Justification for reduced test configurations for WIFI channels per KDB Publication 248227 and April 2010 FCC/TCB Meeting Notes: Highest average RF output power channel for the lowest data rate were selected for SAR evaluation (as the default channel). Higher data rates were not investigated since the average output powers were not greater than 0.25 dB than that of the corresponding channel in the lowest data rate IEEE 802.11a modes. IEEE 802.11n was additionally tested since the average output powers were more than 0.25 dB higher than IEEE 802.11a conducted powers.
- Per FCC Publication 248227 D01 when the maximum extrapolated peak SAR of the zoom scan for the maximum output channel is >1.6 W/kg or the 1g averaged SAR is >0.8 W/kg, SAR testing was additionally performed on the corresponding default test channels or required test channel based on highest output power.
- corresponding required test channels.
- There is no power reduction for WIFI.
- To confirm the proper SAR liquid depth, the z-axis plots from the system verifications were included since the system verifications were performed using the same liquid, probe, DAE and phantom as the SAR tests.

FCC ID: IHDP56MJ2	 PCTEST ENGINEERING LABORATORY, INC.	SAR EVALUATION REPORT		Reviewed by: Quality Manager
Filename: OY1111161998.IHD	Test Dates: 11/16/11	EUT Type: Portable Tablet Computer	Page 17 of 22	

13 EQUIPMENT LIST

Manufacturer	Model	Description	Cal Date	Cal Interval	Cal Due	Serial Number
Anritsu	MA2481A	Power Sensor	2/7/2011	Annual	2/7/2012	5318
Anritsu	MA2481A	Power Sensor	2/7/2011	Annual	2/7/2012	5442
Anritsu	ML2438A	Power Meter	2/7/2011	Annual	2/7/2012	1190013
Anritsu	ML2438A	Power Meter	2/7/2011	Annual	2/7/2012	98150041
Anritsu	ML2438A	Power Meter	2/7/2011	Annual	2/7/2012	1070030
Anritsu	MA2481A	Power Sensor	2/7/2011	Annual	2/7/2012	5821
Anritsu	MA2481A	Power Sensor	2/7/2011	Annual	2/7/2012	8013
Anritsu	MA2481A	Power Sensor	2/7/2011	Annual	2/7/2012	5605
Anritsu	MA2481A	Power Sensor	2/7/2011	Annual	2/7/2012	2400
Agilent	E5515C	Wireless Communications Test Set	2/8/2011	Annual	2/8/2012	GB45360985
SPEAG	D5GHzV2	5 GHz SAR Dipole	2/11/2011	Annual	2/11/2012	1057
VWR	36934-158	Wall-Mounted Thermometer	2/26/2010	Biennial	2/26/2012	101536273
Agilent	8648D	Signal Generator	4/5/2011	Annual	4/5/2012	3629U00687
Rohde & Schwarz	SMIQ03B	Signal Generator	4/6/2011	Annual	4/6/2012	DE27259
Agilent	E8257D	(250kHz-20GHz) Signal Generator	4/8/2011	Annual	4/8/2012	MY45470194
Rohde & Schwarz	CMU200	Base Station Simulator	4/19/2011	Annual	4/19/2012	107826
SPEAG	DAE4	Dasy Data Acquisition Electronics	4/20/2011	Annual	4/20/2012	665
Agilent	8753E	(30kHz-6GHz) Network Analyzer	4/21/2011	Annual	4/21/2012	JP38020182
Agilent	E5515C	Wireless Communications Tester	4/21/2011	Annual	4/21/2012	US41140256
VWR	36934-158	Wall-Mounted Thermometer	5/26/2010	Biennial	5/26/2012	101718589
Rohde & Schwarz	CMU200	Base Station Simulator	6/1/2011	Annual	6/1/2012	833855/0010
Agilent	E5515C	Wireless Communications Test Set	7/6/2011	Annual	7/6/2012	GB41450275
Agilent	E5515C	Wireless Communications Test Set	7/6/2011	Annual	7/6/2012	GB43304447
SPEAG	EX3DV4	SAR Probe	7/27/2011	Annual	7/27/2012	3561
Rohde & Schwarz	CMW500	LTE Radio Communication Tester	8/5/2011	Annual	8/5/2012	112347
Rohde & Schwarz	CMW500	LTE Radio Communication Tester	8/25/2011	Annual	8/25/2012	100976
Rohde & Schwarz	CMW500	LTE Radio Communication Tester	10/7/2011	Annual	10/7/2012	103962
Agilent	8648D	(9kHz-4GHz) Signal Generator	10/10/2011	Annual	10/10/2012	3613A00315
Agilent	E5515C	Wireless Communications Test Set	10/10/2011	Annual	10/10/2012	GB46110872
Gigatronics	80701A	(0.05-18GHz) Power Sensor	10/12/2011	Annual	10/12/2012	1833460
Gigatronics	8651A	Universal Power Meter	10/12/2011	Annual	10/12/2012	8650319
VWR	36934-158	Wall-Mounted Thermometer	1/21/2011	Biennial	1/21/2013	111286445
VWR	36934-158	Wall-Mounted Thermometer	1/21/2011	Biennial	1/21/2013	111286460
VWR	36934-158	Wall-Mounted Thermometer	1/21/2011	Biennial	1/21/2013	111286454
Control Company	61220-416	Long-Stem Thermometer	2/15/2011	Biennial	2/15/2013	111331322
Control Company	61220-416	Long-Stem Thermometer	2/15/2011	Biennial	2/15/2013	111331323
Control Company	61220-416	Long-Stem Thermometer	2/15/2011	Biennial	2/15/2013	111331330
Control Company	61220-416	Long-Stem Thermometer	2/15/2011	Biennial	2/15/2013	111331332
Control Company	61220-416	Long-Stem Thermometer	3/16/2011	Biennial	3/16/2013	111391601
Rohde & Schwarz	NRVD	Dual Channel Power Meter	4/8/2011	Biennial	4/8/2013	101695
Index SAR	IXTL-010	Dielectric Measurement Kit	N/A		N/A	N/A
Index SAR	IXTL-030	30MM TEM line for 6 GHz	N/A		N/A	N/A
Pasternack	PE2208-6	Bidirectional Coupler	N/A		N/A	N/A
Pasternack	PE2209-10	Bidirectional Coupler	N/A		N/A	N/A
Amplifier Research	5S1G4	5W, 800MHz-4.2GHz	N/A		N/A	21910
Mini-Circuits	BW-N20W5+	DC to 18 GHz Precision Fixed 20 dB Attenuator	N/A		N/A	N/A
MiniCircuits	SLP-2400+	Low Pass Filter	N/A		N/A	R8979500903
Narda	4772-3	Attenuator (3dB)	N/A		N/A	9406
Narda	BW-S3W2	Attenuator (3dB)	N/A		N/A	120
Mini-Circuits	NLP-2950+	Low Pass Filter DC to 2700 MHz	N/A		N/A	N/A
Mini-Circuits	NLP-1200+	Low Pass Filter DC to 1000 MHz	N/A		N/A	N/A



FCC ID: IHDP56MJ2	 PCTEST ENGINEERING LABORATORY, INC.	SAR EVALUATION REPORT		Reviewed by: Quality Manager
Filename: OY1111161998.IHD	Test Dates: 11/16/11	EUT Type: Portable Tablet Computer		Page 18 of 22

14 MEASUREMENT UNCERTAINTIES

Applicable for 5 GHz.

a	b	c	d	e= f(d,k)	f	g	h = c x f/e	i = c x g/e	k	
Uncertainty Component	IEEE 1528 Sec.	Tol. (± %)	Prob. Dist.	Div.	c _i 1gm	c _i 10 gms	1gm u _i (± %)	10gms u _i (± %)	v _i	
Measurement System										
Probe Calibration	E.2.1	6.55	N	1	1.0	1.0	6.6	6.6	∞	
Axial Isotropy	E.2.2	0.25	N	1	0.7	0.7	0.2	0.2	∞	
Hemishperical Isotropy	E.2.2	1.3	N	1	1.0	1.0	1.3	1.3	∞	
Boundary Effect	E.2.3	0.4	N	1	1.0	1.0	0.4	0.4	∞	
Linearity	E.2.4	0.3	N	1	1.0	1.0	0.3	0.3	∞	
System Detection Limits	E.2.5	5.1	N	1	1.0	1.0	5.1	5.1	∞	
Readout Electronics	E.2.6	1.0	N	1	1.0	1.0	1.0	1.0	∞	
Response Time	E.2.7	0.8	R	1.73	1.0	1.0	0.5	0.5	∞	
Integration Time	E.2.8	2.6	R	1.73	1.0	1.0	1.5	1.5	∞	
RF Ambient Conditions	E.6.1	3.0	R	1.73	1.0	1.0	1.7	1.7	∞	
Probe Positioner Mechanical Tolerance	E.6.2	0.4	R	1.73	1.0	1.0	0.2	0.2	∞	
Probe Positioning w/ respect to Phantom	E.6.3	2.9	R	1.73	1.0	1.0	1.7	1.7	∞	
Extrapolation, Interpolation & Integration algorithms for Max. SAR Evaluation	E.5	1.0	R	1.73	1.0	1.0	0.6	0.6	∞	
Test Sample Related										
Test Sample Positioning	E.4.2	6.0	N	1	1.0	1.0	6.0	6.0	287	
Device Holder Uncertainty	E.4.1	3.32	R	1.73	1.0	1.0	1.9	1.9	∞	
Output Power Variation - SAR drift measurement	6.6.2	5.0	R	1.73	1.0	1.0	2.9	2.9	∞	
Phantom & Tissue Parameters										
Phantom Uncertainty (Shape & Thickness tolerances)	E.3.1	4.0	R	1.73	1.0	1.0	2.3	2.3	∞	
Liquid Conductivity - deviation from target values	E.3.2	5.0	R	1.73	0.64	0.43	1.8	1.2	∞	
Liquid Conductivity - measurement uncertainty	E.3.3	3.8	N	1	0.64	0.43	2.4	1.6	6	
Liquid Permittivity - deviation from target values	E.3.2	5.0	R	1.73	0.60	0.49	1.7	1.4	∞	
Liquid Permittivity - measurement uncertainty	E.3.3	4.5	N	1	0.60	0.49	2.7	2.2	6	
Combined Standard Uncertainty (k=1)							RSS	12.4	12.0	299
Expanded Uncertainty (95% CONFIDENCE LEVEL)							k=2	24.7	24.0	

The above measurement uncertainties are according to IEEE Std. 1528-2003



FCC ID: IHDP56MJ2		SAR EVALUATION REPORT		Reviewed by: Quality Manager
Filename: OY1111161998.IHD	Test Dates: 11/16/11	EUT Type: Portable Tablet Computer		Page 19 of 22

15 CONCLUSION

15.1 Measurement Conclusion



The SAR evaluation indicates that the EUT complies with the RF radiation exposure limits of the FCC and Industry Canada, with respect to all parameters indicated in this test report for 5 GHz WIFI only. These measurements were taken to simulate the RF effects of RF exposure under worst-case conditions. Precise laboratory measures were taken to assure repeatability of the tests. The results and statements relate only to the item(s) tested.

Please note that the absorption and distribution of electromagnetic energy in the body are very complex phenomena that depend on the mass, shape, and size of the body, the orientation of the body with respect to the field vectors, and the electrical properties of both the body and the environment. Other variables that may play a substantial role in possible biological effects are those that characterize the environment (e.g. ambient temperature, air velocity, relative humidity, and body insulation) and those that characterize the individual (e.g. age, gender, activity level, debilitation, or disease). Because various factors may interact with one another to vary the specific biological outcome of an exposure to electromagnetic fields, any protection guide should consider maximal amplification of biological effects as a result of field-body interactions, environmental conditions, and physiological variables. [3]



FCC ID: IHDP56MJ2		SAR EVALUATION REPORT		Reviewed by: Quality Manager
Filename: 0Y1111161998.IHD	Test Dates: 11/16/11	EUT Type: Portable Tablet Computer	Page 20 of 22	

16 REFERENCES

- [1] Federal Communications Commission, ET Docket 93-62, Guidelines for Evaluating the Environmental Effects of Radiofrequency Radiation, Aug. 1996.
- [2] ANSI/IEEE C95.1-2005, American National Standard safety levels with respect to human exposure to radio frequency electromagnetic fields, 300kHz to 100GHz, New York: IEEE, 2006.
- [3] ANSI/IEEE C95.1-1992, American National Standard safety levels with respect to human exposure to radio frequency electromagnetic fields, 300kHz to 100GHz, New York: IEEE, Sept. 1992.
- [4] ANSI/IEEE C95.3-2002, IEEE Recommended Practice for the Measurement of Potentially Hazardous Electromagnetic Fields - RF and Microwave, New York: IEEE, December 2002.
- [5] Federal Communications Commission, OET Bulletin 65 (Edition 97-01), Supplement C (Edition 01-01), Evaluating Compliance with FCC Guidelines for Human Exposure to Radiofrequency Electromagnetic Fields, June 2001.
- [6] IEEE Standards Coordinating Committee 34 – IEEE Std. 1528-2003, Recommended Practice for Determining the Peak Spatial-Average Specific Absorption Rate (SAR) in the Human Body Due to Wireless Communications Devices.
- [7] NCRP, National Council on Radiation Protection and Measurements, Biological Effects and Exposure Criteria for RadioFrequency Electromagnetic Fields, NCRP Report No. 86, 1986. Reprinted Feb. 1995.
- [8] T. Schmid, O. Egger, N. Kuster, Automated E-field scanning system for dosimetric assessments, IEEE Transaction on Microwave Theory and Techniques, vol. 44, Jan. 1996, pp. 105-113.
- [9] K. Pokovic, T. Schmid, N. Kuster, Robust setup for precise calibration of E-field probes in tissue simulating liquids at mobile communications frequencies, ICECOM97, Oct. 1997, pp. 120-124.
- [10] K. Pokovic, T. Schmid, and N. Kuster, E-field Probe with improved isotropy in brain simulating liquids, Proceedings of the ELMAR, Zadar, Croatia, June 23-25, 1996, pp. 172-175.
- [11] Schmid & Partner Engineering AG, Application Note: Data Storage and Evaluation, June 1998, p2.
- [12] V. Hombach, K. Meier, M. Burkhardt, E. Kuhn, N. Kuster, The Dependence of EM Energy Absorption upon Human Head Modeling at 900 MHz, IEEE Transaction on Microwave Theory and Techniques, vol. 44 no. 10, Oct. 1996, pp. 1865-1873.
- [13] N. Kuster and Q. Balzano, Energy absorption mechanism by biological bodies in the near field of dipole antennas above 300MHz, IEEE Transaction on Vehicular Technology, vol. 41, no. 1, Feb. 1992, pp. 17-23.
- [14] G. Hartsgrrove, A. Kraszewski, A. Surowiec, Simulated Biological Materials for Electromagnetic Radiation Absorption Studies, University of Ottawa, Bioelectromagnetics, Canada: 1987, pp. 29-36.
- [15] Q. Balzano, O. Garay, T. Manning Jr., Electromagnetic Energy Exposure of Simulated Users of Portable Cellular Telephones, IEEE Transactions on Vehicular Technology, vol. 44, no.3, Aug. 1995.
- [16] W. Gander, Computermathematik, Birkhaeuser, Basel, 1992.
- [17] W.H. Press, S.A. Teukolsky, W.T. Vetterling, and B.P. Flannery, Numerical Recipes in C, The Art of Scientific Computing, Second edition, Cambridge University Press, 1992.
- [18] Federal Communications Commission, OET Bulletin 65, Evaluating Compliance with FCC Guidelines for Human Exposure to Radiofrequency Electromagnetic Fields. Supplement C, Dec. 1997.

FCC ID: IHDP56MJ2		SAR EVALUATION REPORT		Reviewed by: Quality Manager
Filename: 0Y1111161998.IHD	Test Dates: 11/16/11	EUT Type: Portable Tablet Computer		Page 21 of 22

- [19] N. Kuster, R. Kastle, T. Schmid, Dosimetric evaluation of mobile communications equipment with known precision, IEEE Transaction on Communications, vol. E80-B, no. 5, May 1997, pp. 645-652.
- [20] CENELEC CLC/SC111B, European Prestandard (prENV 50166-2), Human Exposure to Electromagnetic Fields High-frequency: 10kHz-300GHz, Jan. 1995.
- [21] Prof. Dr. Niels Kuster, ETH, Eidgenössische Technische Hochschule Zürich, Dosimetric Evaluation of the Cellular Phone.
- [22] IEC 62209-1, Human exposure to radio frequency fields from hand-held and body-mounted wireless communication devices - Human models, instrumentation, and procedures - Part 1: Procedure to determine the specific absorption rate (SAR) for hand-held devices used in close proximity to the ear (frequency range of 300 MHz to 3 GHz), Feb. 2005.
- [23] Industry Canada RSS-102 Radio Frequency Exposure Compliance of Radiocommunication Apparatus (All Frequency Bands) Issue 4, March 2010.
- [24] Health Canada Safety Code 6 Limits of Human Exposure to Radio Frequency Electromagnetic Fields in the Frequency Range from 3 kHz – 300 GHz, 2009
- [25] FCC Public Notice DA-02-1438. Office of Engineering and Technology Announces a Transition Period for the Phantom Requirements of Supplement C to OET Bulletin 65, June 19, 2002
- [26] FCC SAR Measurement Procedures for 3G Devices KDB Publication 941225
- [27] SAR Measurement procedures for IEEE 802.11a/b/g KDB Publication 248227
- [28] FCC SAR Considerations for Handsets with Multiple Transmitters and Antennas, KDB Publication 648474
- [29] FCC Application Note for SAR Probe Calibration and System Verification Consideration for Measurements at 150 MHz – 3 GHz, KDB Publication 450824
- [30] FCC SAR Evaluation Considerations for Laptop Computers with Antennas Built-in on Display Screens, KDB Publication 616217
- [31] FCC SAR Measurement Requirements for 3 – 6 GHz, KDB Publication 865664
- [32] FCC Mobile Portable RF Exposure Procedure, KDB Publication 447498
- [33] FCC SAR Procedures for Dongle Transmitters, KDB Publication 447498
- [34] Anexo à Resolução No. 533, de 10 de Setembro de 2009.
- [35] FCC SAR Test Considerations for LTE Handsets and Data Modems, KDB Publication 941225.
- [36] IEC 62209-2, Human exposure to radio frequency fields from hand-held and body-mounted wireless communication devices - Human models, instrumentation, and procedures - Part 2: Procedure to determine the specific absorption rate (SAR) for wireless communication devices used in close proximity to the human body (frequency range of 30 MHz to 6 GHz), Mar. 2010.
- [37] FCC Hot Spot SAR v01, KDB Publication 941225 D06.

FCC ID: IHDP56MJ2		SAR EVALUATION REPORT		Reviewed by: Quality Manager
Filename: 0Y1111161998.IHD	Test Dates: 11/16/11	EUT Type: Portable Tablet Computer	Page 22 of 22	

APPENDIX A: SAR TEST DATA

PCTEST ENGINEERING LABORATORY, INC.

DUT: IHDP56MJ2 ; Type: Portable Tablet Computer; Serial: TA3020010B

Communication System: IEEE 802.11a 5.2-5.8 GHz Band; Frequency: 5825 MHz; Duty Cycle: 1:1

Medium: 5 GHz Body Medium parameters used:

$f = 5825 \text{ MHz}$; $\sigma = 6.247 \text{ mho/m}$; $\epsilon_r = 45.92$; $\rho = 1000 \text{ kg/m}^3$

Phantom section: Flat Section; Space: 0.0 cm

Test Date: 11-16-2011; Ambient Temp: 24.1°C; Tissue Temp: 22.9°C

Probe: EX3DV4 - SN3561; ConvF(3.34, 3.34, 3.34); Calibrated: 7/27/2011

Sensor-Surface: 2mm (Mechanical Surface Detection)

Electronics: DAE4 Sn665; Calibrated: 4/20/2011

Phantom: SAM Sub; Type: SAM 4.0; Serial: TP-1357

Measurement SW: DASY4, V4.7 Build 80; Postprocessing SW: SEMCAD, V1.8 Build 186

Mode: IEEE 802.11a, 5.8 GHz, Body SAR, Ch 165, 6 Mbps, Back Side

Area Scan (13x27x1): Measurement grid: dx=10mm, dy=10mm

Zoom Scan (8x8x11)/Cube 0: Measurement grid: dx=4mm, dy=4mm, dz=2mm

Reference Value = 12.1 V/m; Power Drift = -0.162 dB

Peak SAR (extrapolated) = 3.98 W/kg

SAR(1 g) = 0.614 mW/g; SAR(10 g) = 0.160 mW/g

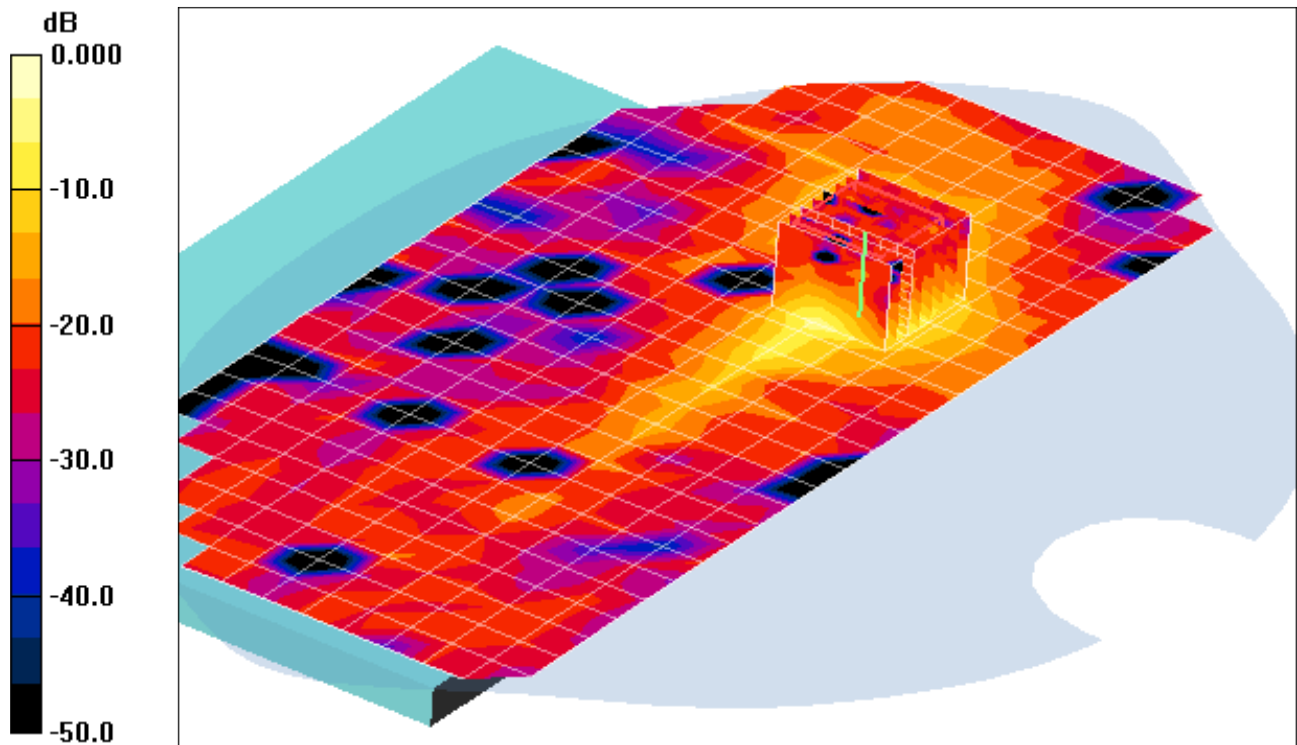

0 dB = 1.52mW/g

PCTEST ENGINEERING LABORATORY, INC.

DUT: IHDP56MJ2 ; Type: Portable Tablet Computer; Serial: TA3020010B

Communication System: IEEE 802.11a 5.2-5.8 GHz Band; Frequency: 5805 MHz; Duty Cycle: 1:1

Medium: 5 GHz Body Medium parameters used:

$f = 5805 \text{ MHz}$; $\sigma = 6.191 \text{ mho/m}$; $\epsilon_r = 45.90$; $\rho = 1000 \text{ kg/m}^3$

Phantom section: Flat Section; Space: 0.0 cm

Test Date: 11-16-2011; Ambient Temp: 24.1°C; Tissue Temp: 22.9°C

Probe: EX3DV4 - SN3561; ConvF(3.34, 3.34, 3.34); Calibrated: 7/27/2011

Sensor-Surface: 2mm (Mechanical Surface Detection)

Electronics: DAE4 Sn665; Calibrated: 4/20/2011

Phantom: SAM Sub; Type: SAM 4.0; Serial: TP-1357

Measurement SW: DASY4, V4.7 Build 80; Postprocessing SW: SEMCAD, V1.8 Build 186

Mode: IEEE 802.11a, 5.8 GHz, Body SAR, Ch 161, 6 Mbps, Right Side

Area Scan (6x27x1): Measurement grid: $dx=10\text{mm}$, $dy=10\text{mm}$

Zoom Scan (7x7x11)/Cube 0: Measurement grid: $dx=4\text{mm}$, $dy=4\text{mm}$, $dz=2\text{mm}$

Reference Value = 12.8 V/m; Power Drift = 0.092 dB

Peak SAR (extrapolated) = 3.54 W/kg

SAR(1 g) = 0.646 mW/g; SAR(10 g) = 0.162 mW/g

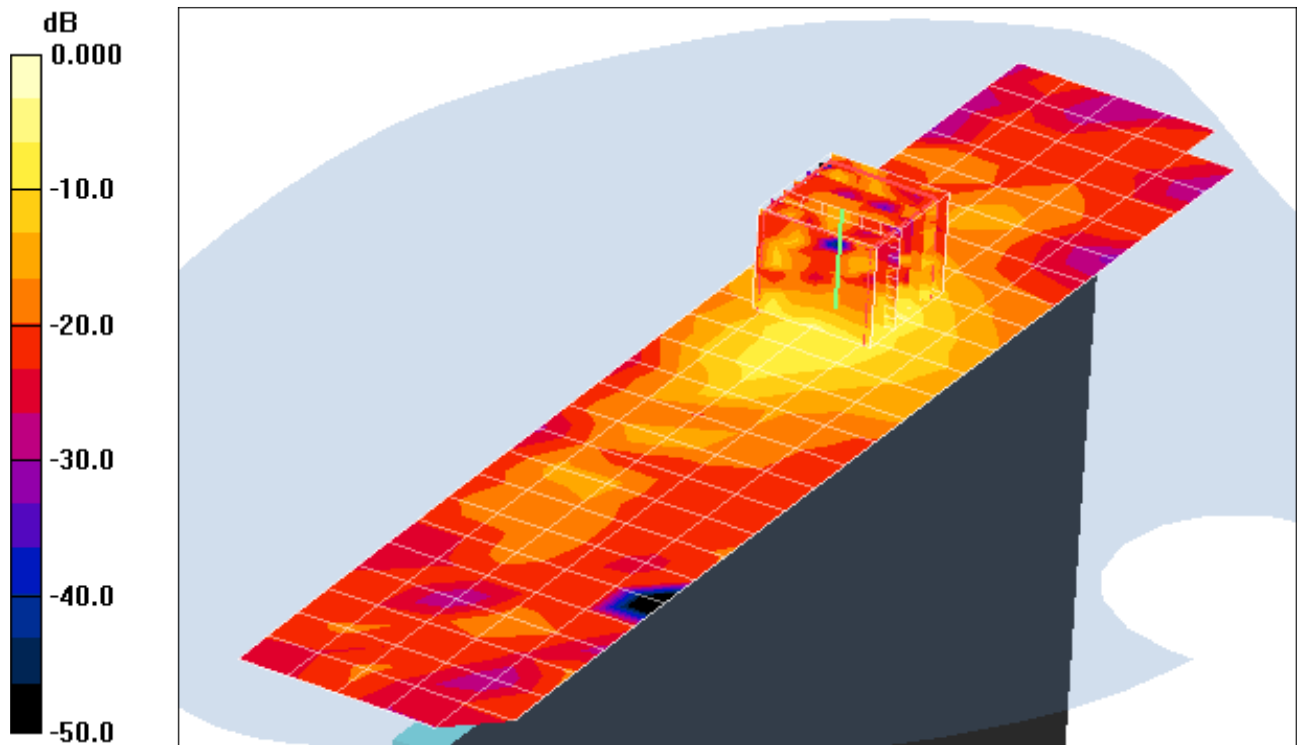

APPENDIX B: DIPOLE VALIDATION

PCTEST ENGINEERING LABORATORY, INC.

DUT: Dipole 5200 MHz; Type: D5GHzV2; Serial: 1057

Communication System: CW; Frequency: 5200 MHz; Duty Cycle: 1:1

Medium: 5 GHz Body Medium parameters used:

$f = 5200 \text{ MHz}$; $\sigma = 5.386 \text{ mho/m}$; $\epsilon_r = 47.06$; $\rho = 1000 \text{ kg/m}^3$

Phantom section: Flat Section; Space: 1.0 cm

Test Date: 11-16-2011; Ambient Temp: 24.5°C; Tissue Temp: 23.0°C

Probe: EX3DV4 - SN3561; ConvF(3.7, 3.7, 3.7); Calibrated: 7/27/2011

Sensor-Surface: 2mm (Mechanical Surface Detection)

Electronics: DAE4 Sn665; Calibrated: 4/20/2011

Phantom: SAM Sub; Type: SAM 4.0; Serial: TP-1357

Measurement SW: DASY4, V4.7 Build 80; Postprocessing SW: SEMCAD, V1.8 Build 186

5200MHz System Verification

Area Scan (7x9x1): Measurement grid: $dx=10\text{mm}$, $dy=10\text{mm}$

Zoom Scan (7x7x11)/Cube 0: Measurement grid: $dx=4\text{mm}$, $dy=4\text{mm}$, $dz=2\text{mm}$

Input Power = 20.0 dBm (100 mW)

SAR(1 g) = 8.3 mW/g; SAR(10 g) = 2.31 mW/g

Deviation = 6.82 %

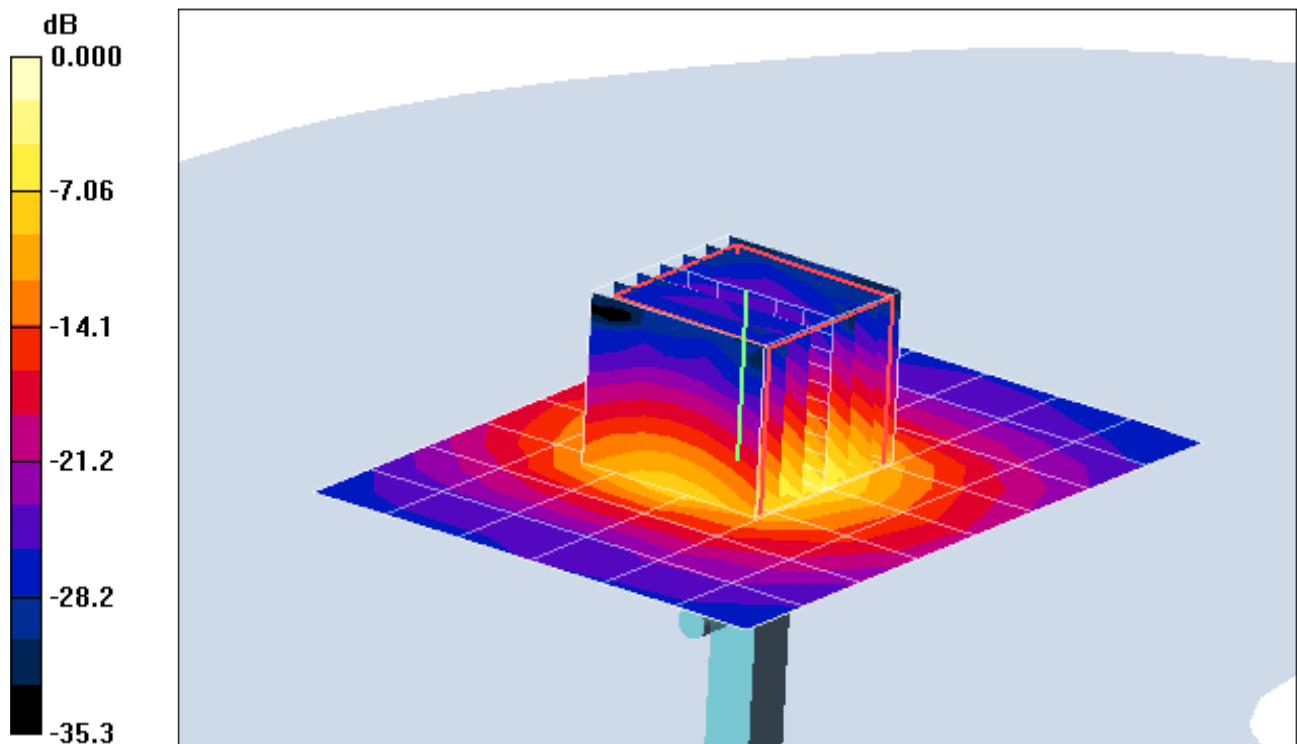

0 dB = 17.0mW/g

PCTEST ENGINEERING LABORATORY, INC.

DUT: Dipole 5200 MHz; Type: D5GHzV2; Serial: 1057

Communication System: CW; Frequency: 5200 MHz; Duty Cycle: 1:1

Medium: 5 GHz Body Medium parameters used:

$f = 5200 \text{ MHz}$; $\sigma = 5.386 \text{ mho/m}$; $\epsilon_r = 47.06$; $\rho = 1000 \text{ kg/m}^3$

Phantom section: Flat Section; Space: 1.0 cm

Test Date: 11-16-2011; Ambient Temp: 24.5°C; Tissue Temp: 23.0°C

Probe: EX3DV4 - SN3561; ConvF(3.7, 3.7, 3.7); Calibrated: 7/27/2011

Sensor-Surface: 2mm (Mechanical Surface Detection)

Electronics: DAE4 Sn665; Calibrated: 4/20/2011

Phantom: SAM Sub; Type: SAM 4.0; Serial: TP-1357

Measurement SW: DASY4, V4.7 Build 80; Postprocessing SW: SEMCAD, V1.8 Build 186

5200MHz System Verification

Area Scan (7x9x1): Measurement grid: dx=10mm, dy=10mm

Zoom Scan (7x7x11)/Cube 0: Measurement grid: dx=4mm, dy=4mm, dz=2mm

Input Power = 20.0 dBm (100 mW)

SAR(1 g) = 8.3 mW/g; SAR(10 g) = 2.31 mW/g

Deviation = 6.82 %

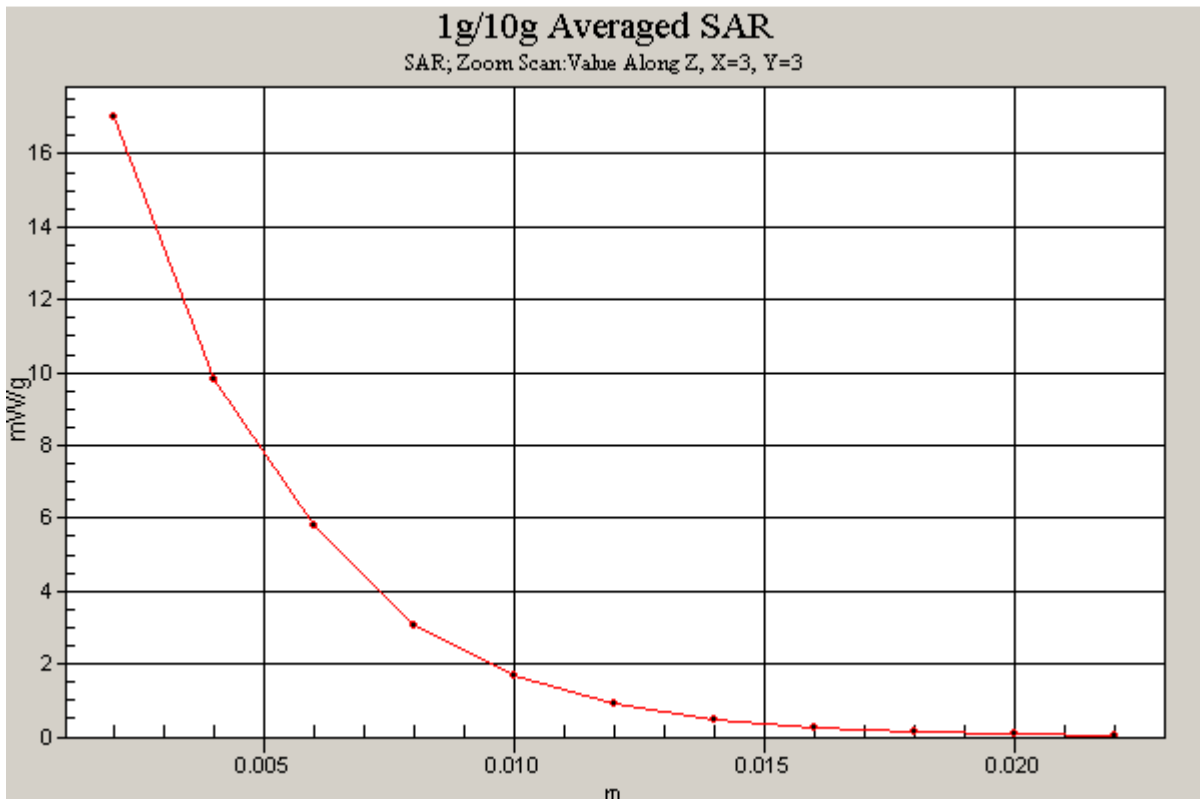

PCTEST ENGINEERING LABORATORY, INC.

DUT: Dipole 5800 MHz; Type: D5GHzV2; Serial: 1057

Communication System: CW; Frequency: 5800 MHz; Duty Cycle: 1:1

Medium: 5 GHz Body Medium parameters used:

$f = 5800 \text{ MHz}$; $\sigma = 6.199 \text{ mho/m}$; $\epsilon_r = 45.93$; $\rho = 1000 \text{ kg/m}^3$

Phantom section: Flat Section; Space: 1.0 cm

Test Date: 11-16-2011; Ambient Temp: 24.1°C; Tissue Temp: 22.9°C

Probe: EX3DV4 - SN3561; ConvF(3.34, 3.34, 3.34); Calibrated: 7/27/2011

Sensor-Surface: 2mm (Mechanical Surface Detection)

Electronics: DAE4 Sn665; Calibrated: 4/20/2011

Phantom: SAM Sub; Type: SAM 4.0; Serial: TP-1357

Measurement SW: DASY4, V4.7 Build 80; Postprocessing SW: SEMCAD, V1.8 Build 186

5800MHz System Verification

Area Scan (7x9x1): Measurement grid: dx=10mm, dy=10mm

Zoom Scan (7x7x11)/Cube 0: Measurement grid: dx=4mm, dy=4mm, dz=2mm

Input Power = 20.0 dBm (100 mW)

SAR(1 g) = 7.89 mW/g; SAR(10 g) = 2.17 mW/g

Deviation = 5.20 %

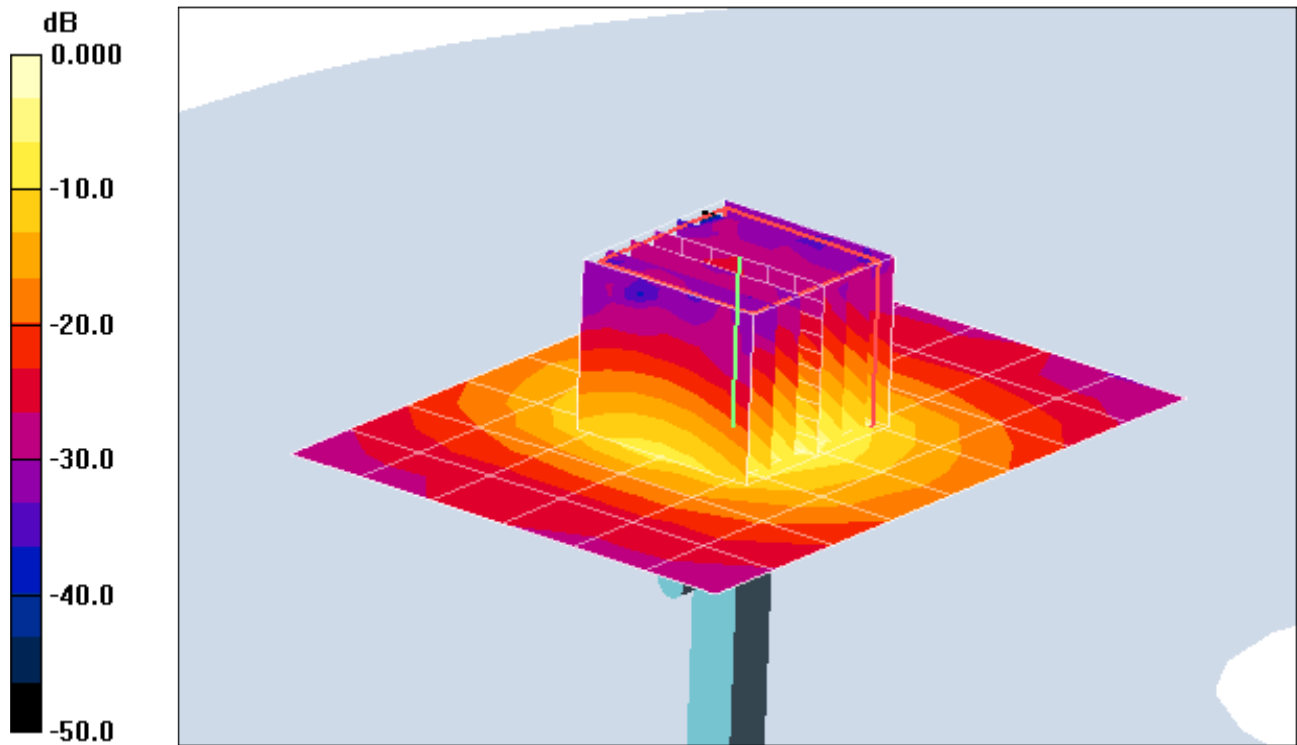

0 dB = 17.0mW/g

PCTEST ENGINEERING LABORATORY, INC.

DUT: Dipole 5800 MHz; Type: D5GHzV2; Serial: 1057

Communication System: CW; Frequency: 5800 MHz; Duty Cycle: 1:1

Medium: 5 GHz Body Medium parameters used:

$f = 5800 \text{ MHz}$; $\sigma = 6.199 \text{ mho/m}$; $\epsilon_T = 45.93$; $\rho = 1000 \text{ kg/m}^3$

Phantom section: Flat Section; Space: 1.0 cm

Test Date: 11-16-2011; Ambient Temp: 24.1°C; Tissue Temp: 22.9°C

Probe: EX3DV4 - SN3561; ConvF(3.34, 3.34, 3.34); Calibrated: 7/27/2011

Sensor-Surface: 2mm (Mechanical Surface Detection)

Electronics: DAE4 Sn665; Calibrated: 4/20/2011

Phantom: SAM Sub; Type: SAM 4.0; Serial: TP-1357

Measurement SW: DASY4, V4.7 Build 80; Postprocessing SW: SEMCAD, V1.8 Build 186

5800MHz System Verification

Area Scan (7x9x1): Measurement grid: dx=10mm, dy=10mm

Zoom Scan (7x7x11)/Cube 0: Measurement grid: dx=4mm, dy=4mm, dz=2mm

Input Power = 20.0 dBm (100 mW)

SAR(1 g) = 7.89 mW/g; SAR(10 g) = 2.17 mW/g

Deviation = 5.20 %

