



MOTOROLA

Portable Hand-Held Device SAR Test Report

Tests Requested By: Motorola Mobility, Inc.
600 N. US Highway 45
Libertyville, IL 60048

Test Report #: 24675-1F Rev C
Date of Report: Dec 2, 2011
Date of Test: Sep-3-2011 to Oct-4-2011
FCC ID #: IHDP56MF2
Generic Name: M0C43

Test Laboratory: Motorola Mobility, Inc. - ADR Test Services Laboratory
600 N. US Highway 45
Libertyville, IL 60048

Report Author: Steven Hauswirth
Distinguished Member of the Technical Staff

This laboratory is accredited to ISO/IEC 17025-2005 to perform the following tests:

Accreditation:



2404

Tests:

Electromagnetic Specific Absorption Rate

Procedures:

IEC 62209-1
RSS-102
IEEE 1528 - 2003
FCC OET Bulletin 65 (*including Supplement C*)
Australian Communications Authority Radio
Communications (Electromagnetic Radiation – Human
Exposure) Standard 2003
CENELEC EN 50360
ARIB Std. T-56 (2002)

On the following products or types of products:

Wireless Communications Devices (Examples): Two Way Radios; Portable Phones (including Cellular, Licensed Non-Broadcast and PCS); Low Frequency Readers; and Pagers

Statement of Compliance:

Motorola declares under its sole responsibility that the portable hand-held device model to which this declaration relates, is in conformity with the appropriate General Population/Uncontrolled RF exposure standards, recommendations and guidelines (FCC 47 CFR §2.1093) as well as with CENELEC en50360:2001 and ANSI / IEEE C95.1. It also declares that the product was tested in accordance with IEEE 1528 / CENELEC EN62209-1 (2006), as well as other appropriate measurement standards, guidelines and recommended practices. Any deviations from these standards, guidelines and recommended practices are noted below:

The general procedures and guidelines provided within; FCC KDB 248227 D01, FCC KDB 648474 D01, FCC KDB 865664 D01 and IEC 62209-2 were utilized for testing.

©Motorola Mobility, Inc. 2011

This test report shall not be reproduced except in full, without written approval of the laboratory. The results and statements contained herein relate only to the items tested. The names of individuals involved may be mentioned only in connection with the statements or results from this report. Motorola encourages all feedback, both positive and negative, on this test report.

Table of Contents

1. Introduction	3
2. Description of the Device Under Test	4
2.1 Antenna description	4
2.2 Device Signaling	5
2.3 Device Conducted Power Measurements	6
2.3.1 GSM/GPRS modes	6
2.3.2 WCDMA modes	6
2.3.3 Wi-Fi 802.11 modes	8
2.4 Power limit reduction schemes	9
3. Test Equipment Used	12
3.1 Dosimetric System	12
3.2 Additional Equipment	12
4. Electrical parameters of the tissue simulating liquid	13
5. System Accuracy Verification	14
6. Test Results	15
6.1 Body Worn Test Results	16
6.2 Evaluation of Simultaneous Transmitters	20
References	24
Appendix 1: SAR distribution comparison for the system accuracy verification	
Appendix 2: SAR distribution plots for Body Configuration	
Appendix 3: SAR distribution plots for Simultaneous Transmission	
Appendix 4: Measurement Uncertainty Budget	
Appendix 5: Probe Calibration Certificate	
Appendix 6: Dipole Characterization Certificate	

Revision History

Revision Version	Date	Notes
Rev. 0	Oct-13-2011	Initial report release.
Rev. A	Nov-3-2011	
Rev. B	Nov 28, 2011	Removed 5GHz SAR data. Added separate report from external test lab for 5 GHz SAR data.
Rev. C	Dec-01-2011	Included pictures for orientation and proximity sensor effective area to section 2.4

1. Introduction

The Motorola Mobility ADR Test Services Laboratory has performed measurements of the maximum potential exposure to the user of the portable Hand-Held Device covered by this test report. The Specific Absorption Rate (SAR) of this product was measured. The portable Hand-Held Device was tested in accordance with [1], [4] and [5]. The SAR values measured for the portable Hand-Held Device are below the maximum recommended levels of 1.6 W/kg in a 1 g average set in [3] and 2.0 W/kg in a 10 g average set in [2].

For ANSI / IEEE C95.1 (1 g), the final stand-alone SAR readings for this device are given in the table below. These measurements were performed using a Dasy4™ v4.7 system manufactured by Schmid & Partner Engineering AG (SPEAG), of Zurich Switzerland.

Summary of Stand-Alone SAR Results	
Transmit Band	Body SAR (1g ^W /kg)
GPRS 850	1.23
WCDMA 850	0.68
GPRS 1900	1.33
WCDMA 1900	1.50
Wi-Fi 2.45 GHz	1.42

SAR test results for body-worn testing in the Wi-Fi 5200 MHz and 5800 MHz transmit bands are provided in report [IHDP56MF2_5GWLAN_SAR_Report.pdf](#), included within the Exhibit 11 documents.

2. Description of the Device Under Test

2.1 Antenna description

GSM / WCDMA (850/1900 MHz) Antenna

Type	Internal	
Location	Top of Transceiver	
Dimensions	Width	9.67 mm
	Length	48.1 mm

Bluetooth/Wi-Fi 2.45 / 5 GHz Antenna

Type	Internal	
Location	Top of Transceiver	
Dimensions	Width	3.67 mm
	Length	10.04 mm



2.2 Device Signaling¹

Serial Number(s) (Functional Use)	KPUA020375 (GPRS & WCDMA conducted power measurements and SAR testing) KPE00G0052 (Wi-Fi SAR testing)
Production Unit or Identical Prototype (47 CFR §2.908)	Identical Prototype
Device Category	Portable / Mobile Station
RF Exposure Limits	General Population / Uncontrolled

Mode(s) of Operation	Modulation Mode(s)	Maximum Output Power Setting	Duty Cycle	Transmitting Frequency Range(s)
GSM 850	GMSK	33.5 dBm	1:8	824.2 - 848.8 MHz
WCDMA 850	QPSK	24.0 dBm	1:1	826.4 - 846.6 MHz
GSM 1900	GMSK	30.5 dBm	1:8	1850.2 - 1909.8 MHz
WCDMA 1900	QPSK	24.0 dBm	1:1	1852.4 - 1907.6 MHz
2.45 GHz Wi-Fi 802.11b/g/n	BPSK	14.5 dBm	1:1	2412.0 - 2462.5 MHz
5 GHz Wi-Fi 802.11a/n	BPSK	12.7 dBm	1:1	5180.0 - 5240.0 MHz, 5745.0 - 5805.0 MHz
Bluetooth	GFSK	7.83 dBm	1:1	2402.0 - 2483.5 MHz

GSM Data Functionality	GPRS/EDGE Class 12 (4 uplink timeslots; 4 downlink timeslots; 5 total timeslots per frame)
	Class B (DTM not supported)

Mode(s) of Operation	GPRS/EDGE 850				GPRS/EDGE 1900			
	GMSK				GMSK			
Maximum Output Power Setting (dBm)	33.5	31.5	29.5	27.5	30.5	30.0	28.0	26.0
Time Average Output Power Setting (dBm)	24.5	25.5	25.2	24.5	21.5	24.0	23.7	23.0
Duty Cycle	1:8	2:8	3:8	4:8	1:8	2:8	3:8	4:8
Transmitting Frequency Range(s)	824.2 - 848.8 MHz				1850.2 - 1909.8 MHz			

Mode(s) of Operation	EDGE 850				EDGE 1900			
	8PSK				8PSK			
Maximum Output Power Setting (dBm)	27.5	26.5	24.5	22.5	26.5	25.5	23.5	21.5
Time Average Output Power Setting (dBm)	18.5	20.5	20.2	19.5	17.5	19.5	19.2	18.5
Duty Cycle	1:8	2:8	3:8	4:8	1:8	2:8	3:8	4:8
Transmitting Frequency Range(s)	824.2 - 848.8 MHz				1850.2 - 1909.8 MHz			

¹ **Bolded** entries indicate data mode configurations of highest time-average power output per band and data mode type, and thus were utilized for SAR testing in this report.

2.3 Device Conducted Power Measurements

2.3.1 GSM/GPRS modes

Band	Channel	Conducted power (dBm) for GSM modes ²								
		GSM CS Voice (1 Slot)	GPRS PS Data (1 Slot)	GPRS PS Data (2 Slots) ³	GPRS PS Data (3 Slots)	GPRS PS Data (4 Slots)	EDGE PS Data (1 Slot)	EDGE PS Data (2 Slots)	EDGE PS Data (3 Slots)	EDGE PS Data (4 Slots)
GSM 850	128	33.41	33.41	31.40	29.41	27.55	27.12	26.58	24.64	22.30
	190	33.30	33.30	31.55	29.42	27.46	26.97	26.43	24.37	22.70
	251	33.34	33.34	31.53	29.39	27.43	26.92	26.30	24.37	22.30
GSM 1900	512	30.42	30.42	29.82	27.96	26.04	26.06	25.47	23.61	21.34
	661	30.44	30.44	29.93	27.96	26.09	25.93	25.36	23.46	21.46
	810	30.60	30.06	29.83	27.82	26.08	26.08	25.39	23.51	21.35

2.3.2 WCDMA modes

Per the “SAR Measurement Procedures for 3G Devices” released in October, 2007, 12.2 kbps RMC, 12.2 kbps AMR, HS-DPCCH Sub-test 1-4, and E-DCH Sub-test 1-5 modes were considered. The conducted power measurements (per section 5.2 of 3GPP TS 34.121) for each mode are shown in the table below.

Band	Channel	Conducted power (dBm) for WCDMA modes		Conducted Power (dBm) for WCDMA – HSDPA (Rel 5) Modes				Conducted Power (dBm) for WCDMA – HSPA (HSUPA/HSDPA-Rel 6) Modes				
		RMC	AMR	Subtest 1	Subtest 2	Subtest 3	Subtest 4	Subtest 1	Subtest 2	Subtest 3	Subtest 4	Subtest 5
WCDMA 850	4132	23.90	23.89	23.89	23.93	23.94	23.94	23.9	23.93	23.91	23.91	23.94
	4180	23.87	23.83	23.84	23.87	23.91	23.88	23.88	23.85	23.87	23.82	23.88
	4233	23.80	23.77	23.80	23.78	23.81	23.80	23.82	23.78	23.81	23.80	23.81
WCDMA 1900	9262	23.95	24.00	23.97	24.05	23.93	24.03	24.00	24.01	24.01	24.02	24.06
	9400	23.89	23.97	23.89	23.98	23.96	23.94	23.92	23.96	23.96	24.00	24.00
	9538	24.01	24.03	24.03	24.04	24.00	24.05	23.99	24.08	24.04	24.10	24.11

Maximum Power Reduction (MPR)

According to 3GPP 25.101 sub-clause 6.2.2, the maximum output power is allowed to be reduced by following the table.

Table 6.1A: UE maximum output power with HS-DPCCH and E-DCH

UE transmit channel configuration	CM (dB)	MPR (dB)
For all combinations of; DPDCH, DPCCH, HS-DPCCH, E-DPDCH and E-DPCCH	$0 \leq CM \leq 3.5$	MAX (CM-1, 0)
Note 1: CM = 1 for $\beta_c/\beta_d = 12/15$, $\beta_{hs}/\beta_c = 24/15$. For all other combinations of DPDCH, DPCCH, HS-DPCCH, E-DPDCH and E-DPCCH the MPR is based on the relative CM difference.		

² CS Voice denotes circuit-switched transmission for voice calling, and PS Data denotes packet-switched transmission for data sessions.

³ **Bolded** entries indicate data mode configurations of highest time-average power output per band and data mode type, and thus were utilized for SAR testing in this report.

The device supports MPR to solve linearity issues (ACLR or SEM) due to the higher peak-to-average ratios (PAR) of the HSUPA signal. This prevents saturating the full range of the TX DAC inside of device and provides a reduced power output to the RF transceiver chip according to the Cubic Metric (a function of the combinations of DPDCH, DPCCH, HS-DPCCH, E-DPDCH and E-DPCCH).

When E-DPDCH channels are present, the beta gains on those channels are reduced first to try to get the power under the allowed limit. If the beta gains are lowered as far as possible, then a hard limiting is applied at the maximum allowed level.

The SW currently recalculates the cubic metric every time the beta gains on the E-DPDCH are reduced. The cubic metric will likely get lower each time this is done. However, there is no reported reduction of maximum output power in the HSUPA mode since the device also provides a mechanism to compensate for the power back-off by increasing the gain of TX_AGC in the transceiver (PA) device.

The end effect is that the DUT output power is identical to the case where there is no MPR in the device.

2.3.3 Wi-Fi 802.11 modes

Per “SAR Measurement Procedures for 802.11 a/b/g Transmitters” (FCC KDB 248227), power measurements were performed for 802.11 operational modes. The conducted power measurements for each mode are shown in the tables below. SAR testing for 802.11 was performed within the transmit band with the transmitter set to the lowest data rate on the default test channels **highlighted in bold** in the tables below. The body positions that resulted in the highest SAR values were further tested on the additional channels within that sub-transmit band. Also the body positions that resulted in the highest SAR values were further tested with the higher data rates **highlighted in blue** in the tables below because of the conducted power difference. Due to the relatively large number of data rates with measured conducted power exceeding the lowest data rate conducted power by more than 0.25 dB, there will be a large number of tests performed on the configuration that results in the highest measured SAR for the lowest data rate.

Band	Channel	Conducted Power (Max AVG in dBm) for 802.11b Mode Data Rates			
		1 Mbps	2 Mbps	5.5 Mbps	11 Mbps
Wi-Fi 2450 MHz	1	13.18	13.24	14.26	14.42
	6	13.17	13.33	14.34	14.23
	11	13.07	13.15	14.03	14.12

Band	Channel	Conducted Power (Max AVG in dBm) for 802.11g Mode Data Rates							
		6 Mbps	9 Mbps	12 Mbps	18 Mbps	24 Mbps	36 Mbps	48 Mbps	54 Mbps
Wi-Fi 2450 MHz	1	13.43	13.46	13.47	13.53	14.01	13.95	13.11	13.32
	6	13.71	13.55	13.58	13.59	14.16	14.04	13.19	13.25
	11	13.48	13.35	13.31	13.33	13.76	13.82	12.94	12.88

Band	Channel	Conducted Power (Max AVG in dBm) for 802.11n Mode Data Rates (20 MHz Channel, 400 ns Guard Interval)							
		7.2 Mbps	14.4 Mbps	21.6 Mbps	28.8 Mbps	43.3 Mbps	57.7 Mbps	65 Mbps	72.2 Mbps
Wi-Fi 2450 MHz	1	13.33	13.37	13.42	13.83	13.88	13.04	12.89	12.15
	6	13.43	13.41	13.54	13.99	14.06	13.03	12.96	12.11
	11	13.25	13.14	13.31	13.79	13.82	12.73	12.83	11.98

Band	Channel	Conducted Power (Max AVG in dBm) for 802.11n Mode Data Rates (20 MHz Channel, 800 ns Guard Interval)							
		6.5 Mbps	13 Mbps	19.5 Mbps	26 Mbps	39 Mbps	52 Mbps	58.5 Mbps	65 Mbps
Wi-Fi 2450 MHz	1	13.33	13.46	13.53	14.13	13.91	13.01	12.94	11.98
	6	13.43	13.41	13.54	14.15	14.06	13.1	13.08	12.32
	11	13.25	13.26	13.39	13.98	13.8	12.94	12.92	11.93

2.4 Power limit reduction schemes

The DUT utilizes a set of reduced limits for the maximum transmit power for specified device configurations and orientations, as described by the tables and plot below. A complete description of this functionality is provided in the “Operational Description” contained within Exhibit 12A. The implementation to trigger the reduction in power requires the device to be radiating, which prevents a conducted power measurement without modification to the unit.

	Proximity Sensor Power Reduction				Orientation Power Reduction			
Mode(s) of Operation	GPRS 850	WCDMA 850	GPRS 1900	WCDMA 1900	GPRS 850	WCDMA 850	GPRS 1900	WCDMA 1900
Duty Cycle	2:8	1:1	2:8	1:1	2:8	1:1	2:8	1:1
Maximum Output Power Setting (dBm)	31.5	24	30.0	24	31.5	24	30.0	24
Time Avg Output Power Setting (dBm)	25.5	24	24.0	24	25.5	24	24.0	24
Reduced Maximum Output Power Setting (dBm)	26.0	17.8	22.5	16.0	28.5	21.4	25.0	18.0
Time Avg Output Power Setting (dBm)	20.0	17.8	16.5	16.0	22.5	21.4	19.0	18.0

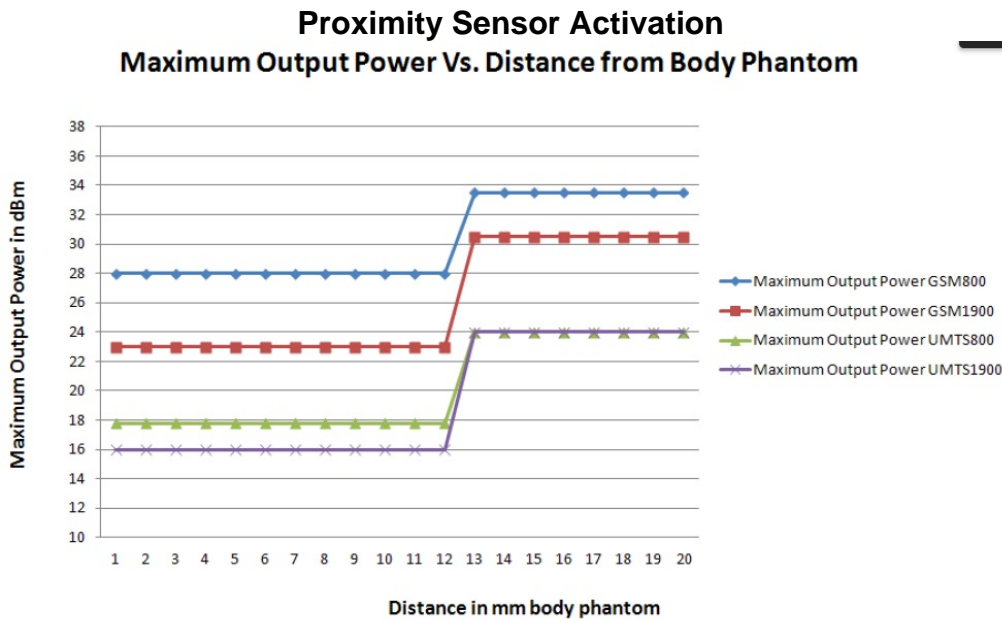

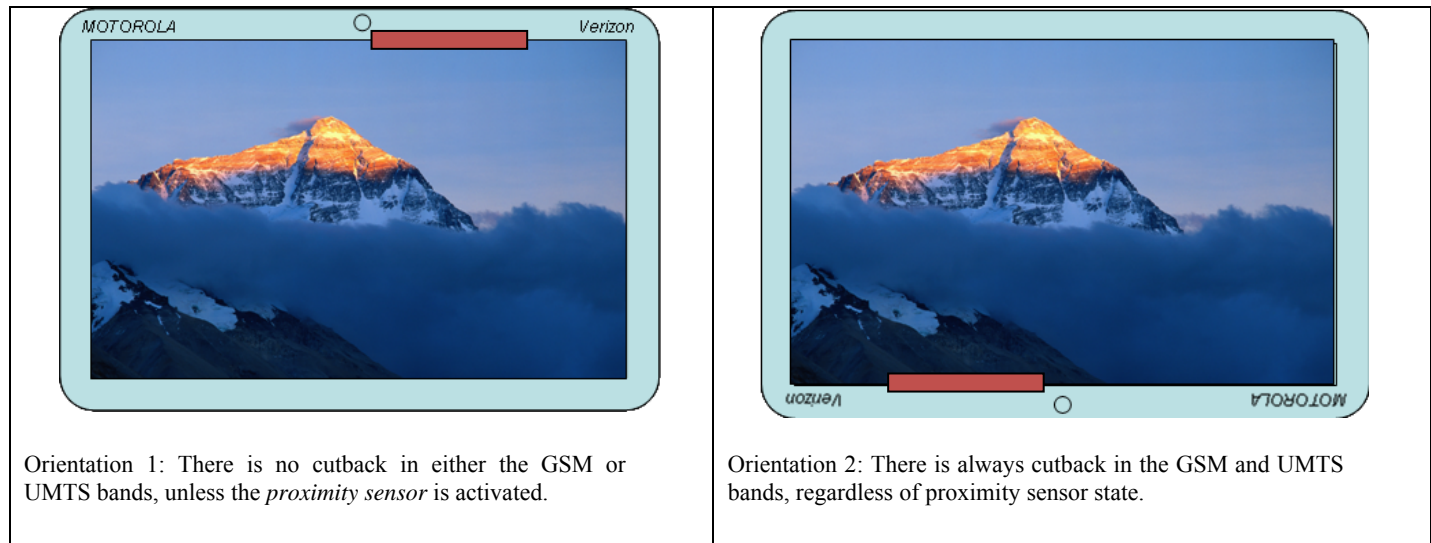

Figure 11.2.4-1: Landscape Usage Modes

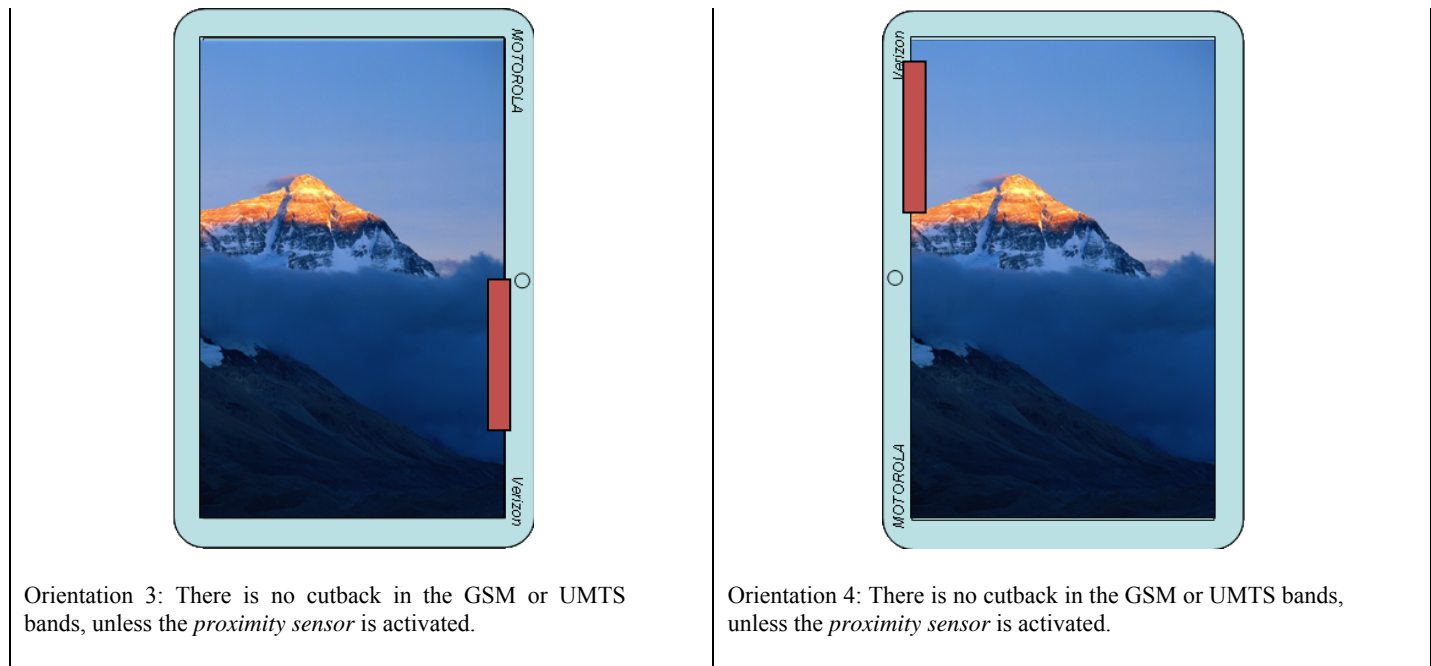

Figure 11.2.4-2: Portrait Usage Modes

Orientation\Mode Power Limit Activation	GPRS 850	WCDMA 850	GPRS 1900	WCDMA 1900
Orientation 1 (Bottom Edge toward body)	N/A	N/A	N/A	N/A
Orientation 2 (Top Edge toward body)	†	†	†	†
Orientation 3 (Right Edge toward body)	N/A	N/A	N/A	N/A
Orientation 4 (Left Edge toward body)	N/A	N/A	N/A	N/A
Back Surface toward body	†	†	†	†

† Reduced maximum limit applied only by activation of proximity sensor.

‡ Reduced maximum limit applied by orientation of device.

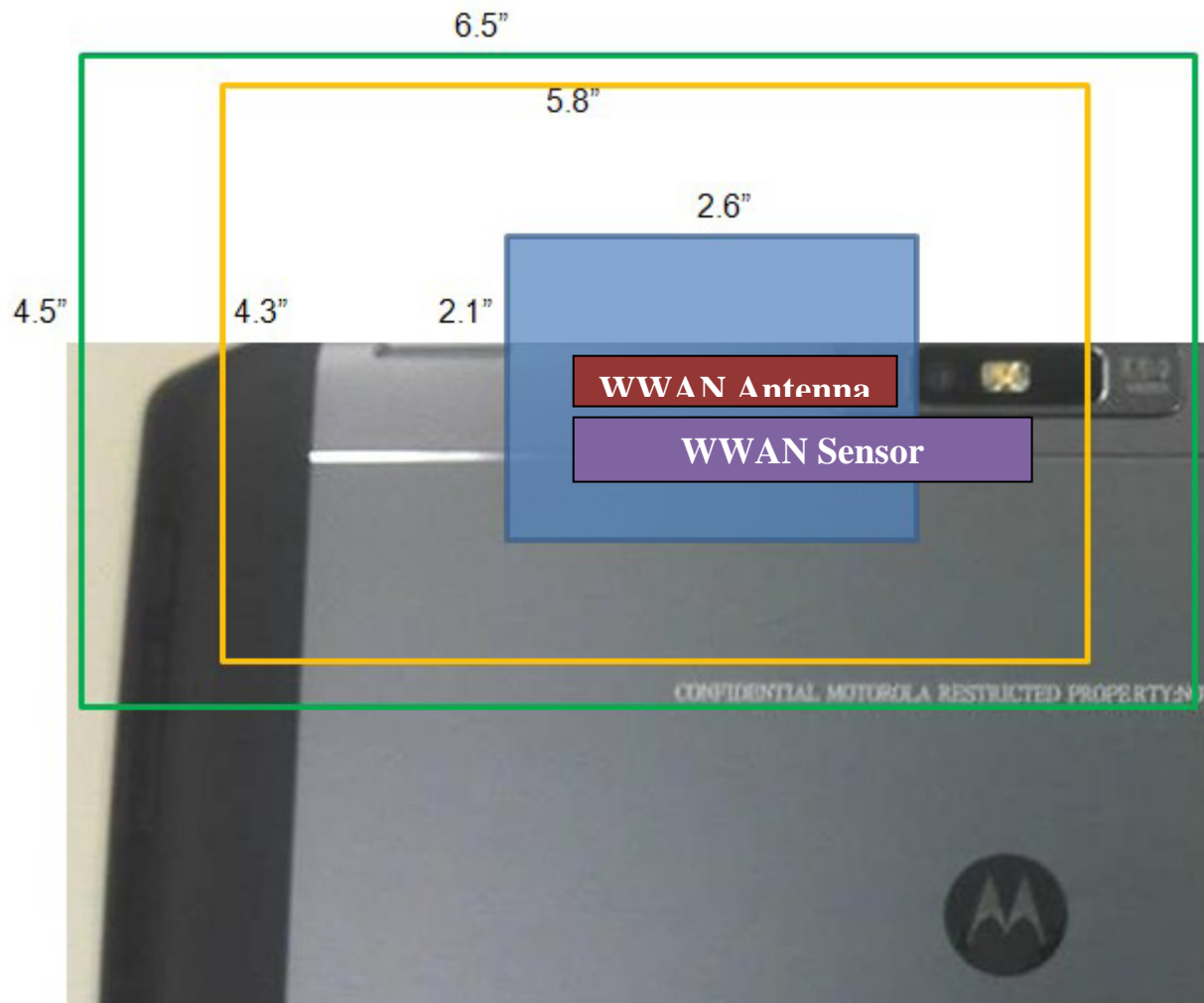

Figure 11.2.4-3: Proximity Detection areas (relative to Main transmitter antenna) at 12-mm threshold separation (orange square) and 1-mm separation (green square). Measurement was done using a 2.6" x 2.1" conductive surface (blue square). Device orientation shown is rear facing outward, top edge up.

3. Test Equipment Used

3.1 Dosimetric System

The Motorola Mobility ADR Test Services Laboratory utilizes a Dosimetric Assessment System (Dasy4™ v4.7) manufactured by Schmid & Partner Engineering AG (SPEAG™), of Zurich Switzerland. All the SAR measurements are taken within a shielded enclosure. The overall 10 g RSS uncertainty of the measurement system is $\pm 10.8\%$ (K=1) with an expanded uncertainty of $\pm 21.6\%$ (K=2). The overall 1 g RSS uncertainty of the measurement system is $\pm 11.1\%$ (K=1) with an expanded uncertainty of $\pm 22.2\%$ (K=2). The measurement uncertainty budget is given in Appendix 5. Per IEEE 1528, this uncertainty budget is applicable to the SAR range of 0.4 W/kg to 10 W/kg.

The list of calibrated equipment used for the measurements is shown in the following table.

Description	Serial Number	Cal Date	Cal Due Date
DASY4™ DAE V1	702	Apr-14-2011	Apr-14-2012
E-Field Probe ES3DV3	3184	Mar-11-2011	Mar-11-2012
DASY4™ DAE V1	434	Jan-13-2011	Jan-13-2012
E-Field Probe ES3DV3	3115	Jan-12-2011	Jan-12-2012
S.A.M. Phantom used for 800/1900/2450 MHz	TP-1136		
S.A.M. Phantom used for 800/1900 MHz	TP-1131		
S.A.M. Phantom used for 5210/5875 MHz	TP-1106		
Dipole Validation Kit, DV835V2	422	Mar-18-2011	Mar-18-2013
Dipole Validation Kit, DV835V2	436	Mar-18-2011	Mar-18-2013
Dipole Validation Kit, DV1800V2	250	Mar-17-2011	Mar-17-2013
Dipole Validation Kit, DV1800V2	259	Mar-17-2011	Mar-17-2013
Dipole Validation Kit, DV1800V2	271	Mar-8-2011	Mar-8-2013
Dipole Validation Kit, DV2450V2	766	Jul-15-2011	Jul-15-2013
Dipole Validation Kit, DV2450V2	740	Mar-17-2011	Mar-17-2013

3.2 Additional Equipment

Description	Serial Number	Cal Date	Cal Due Date
Signal Generator HP8648C	3847A04982	Nov-18-2009	Nov-18-2011
Power Meter E4419B	GB39510900	Mar-28-2011	Mar-28-2013
Power Sensor #1 - E9301A	US39211007	Aug-16-2011	Aug-16-2012
Power Sensor #2 - E9301A	US39211008	Aug-16-2011	Aug-16-2012
Signal Generator HP8648C	3847A04632	Aug-13-2011	Aug-13-2013
Power Meter E4419B	GB39511087	Dec-22-2009	Dec-22-2011
Power Sensor #1 - E9301A	US39211006	Oct-25-2010	Oct-25-2011
Power Sensor #2 - E9301A	US39210934	Oct-25-2010	Oct-25-2011
Signal Generator HP8648C	3847A04843	Mar-28-2011	Mar-28-2013
Power Meter E4419B	GB39511084	Mar-28-2011	Mar-28-2013
Power Sensor #1 - E9301A	US39210929	Mar-31-2011	Mar-31-2012
Power Sensor #2 - E9301A	US39210930	Mar-31-2011	Mar-31-2012
Network Analyzer HP8753ES	US39171846	May-19-2011	May-19-2012
Dielectric Probe Kit HP85070C	US99360070		

4. Electrical parameters of the tissue simulating liquid

Prior to conducting SAR measurements, the relative permittivity, ϵ_r , and the conductivity, σ , of the tissue simulating liquids were measured with a HP85070 Dielectric Probe Kit. These values, along with the temperature of the simulated tissue are shown in the table below. The recommended limits for permittivity and conductivity are also shown. A mass density of $\rho = 1 \text{ g/cm}^3$ was entered into the system in all the cases. It can be seen that the measured parameters are within tolerance of the recommended limits specified in [1] and [5].

E-field probes calibrated at 1810 MHz were used for "1900 MHz" band (1850 MHz - 1910 MHz) SAR measurements. FCC KDB 450824 provides additional requirements on page 3 of 6 for SAR testing that is performed with probe calibration points that are more than 50 MHz removed from the measured bands. The KDB requires; "(2) When nominal tissue dielectric parameters are specified in the probe calibration data, the tissue dielectric parameters measured for routine measurements should be less than the target ϵ_r and higher than the target Sigma values to minimize SAR underestimations". The 1900 MHz simulated tissues listed below meet these criteria.

f (MHz)	Tissue type	Limits / Measured	Dielectric Parameters		
			ϵ_r	σ (S/m)	Temp (°C)
835	Body	Measured, Sep-3-2011	55.6	0.98	20.0
		Measured, Oct-1-2011	55.3	0.99	20.1
		Recommended Limits	55.2 ±5%	0.97 ±5%	18-25
1880	Body	Measured, Sep-5-2011	50.9	1.59	19.6
		Measured, Sep-6-2011	50.8	1.58	19.9
		Measured, Sep-30-2011	50.7	1.58	20.1
		Measured, Oct-01-2011	51.1	1.58	20.2
		Recommended Limits	53.3 ±5%	1.52 ±5%	18-25
2450	Body	Measured, Sep-21-2011	51.6	1.92	19.7
		Measured, Sep-24-2011	52.0	1.92	19.9
		Recommended Limits	52.7 ±5%	1.95 ±5%	18-25

The list of ingredients and the percent composition used for the simulated tissues are indicated in the table below.

Ingredient	835 MHz / 900 MHz Head	835 MHz / 900 MHz Body	1800 MHz / 1900 MHz Head	1800 MHz / 1900 MHz Body	2450 MHz Head	2450 MHz Body
Sugar	57	44.9	--	--	--	--
DGBE	--	--	47	30.8	--	30
Diacetin	--	--	--	--	51	--
Water	40.45	53.06	52.62	68.8	48.75	70
Salt	1.45	0.94	0.38	0.4	0.15	--
HEC	1	1	--	--	--	--
Bact.	0.1	0.1	--	--	0.1	--

5. System Accuracy Verification

A system accuracy verification of the DASY4™ was performed using the measurement equipment listed in Section 3.1. The daily system accuracy verification occurs within the flat section of the SAM phantom.

A SAR measurement was performed to verify the measured SAR was within ±10% from the target SAR indicated in Appendix 6. These frequencies are within ±10% of the compliance test mid-band frequency as required in [1] and [5]. The test was conducted on the same days as the measurement of the DUT. Recommended limits for permittivity and conductivity, specified in [5], are shown in the table below. The obtained results from the system accuracy verification are also displayed in the table below. SAR values are normalized to 1 W forward power delivered to the dipole. It is seen that the system is operating within its specification, as the results are within acceptable tolerance of the reference values. The distributions of SAR compare well with those of the reference measurements (see Appendix 1). For frequencies below 3 GHz, the simulated tissue depth was verified to be 15.0 cm ± 0.5 cm. For frequencies above 3 GHz, the simulated tissue depth was verified to be 10 cm ± 0.5 cm. Z-axis scans showing the SAR penetration are also included in Appendix 1.

f (MHz)	Description	SAR (W/kg), 1 gram	Dielectric Parameters		Ambient Temp (°C)	Tissue Temp (°C)
			ε _r	σ (S/m)		
835	Measured, Sep-3-2011	9.80	55.6	0.98	21.2	19.7
	Recommended Limits	9.77	55.2 ±5%	0.97 ±5%	18-25	18-25
	Measured, Oct-1-2011	9.95	55.3	0.99	21.2	20.5
	Recommended Limits	10.1	55.2 ±5%	0.97 ±5%	18-25	18-25
1800	Measured, Sep-5-2011	40.85	51.2	1.54	19.0	18.9
	Measured, Sep-6-2011	39.50	51.1	1.47	21.2	20.5
	Recommended Limits	37.2	53.3 ±5%	1.52 ±5%	18-25	18-25
	Measured, Sep-30-2011	39.05	51.0	1.48	21.1	20.2
	Recommended Limits	38.5	53.3 ±5%	1.52 ±5%	18-25	18-25
	Measured, Oct-01-2011	37.85	51.4	1.49	21.4	20.0
	Recommended Limits	37.5	53.3 ±5%	1.52 ±5%	18-25	18-25
2450	Measured, Sep-21-2011	49.35	51.6	1.92	21.2	20.5
	Recommended Limits	50.40	52.7 ±10%	1.95 ±5%	18-25	18-25
	Measured, Sep-24-2011	51.0	52.0	1.92	21.3	20.2
	Recommended Limits	51.3	52.7 ±10%	1.95 ±5%	18-25	18-25

The following probe conversion factors were used on the E-Field probe(s) used for the system accuracy verification measurements:

Description	Serial Number	f (MHz)	Conversion Factor	Cal Cert pg #
E-Field Probe ES3DV3	3115	835	5.88	6 of 11
		1810	4.61	6 of 11
E-Field Probe ES3DV3	3184	835	6.10	6 of 11
		1810	4.90	6 of 11
		2450	4.33	6 of 11

6. Test Results

For GPRS and WCDMA modes, the test sample was operated using an actual transmission through a base station simulator. Wi-Fi testing was conducted using manufacturer test mode software, per guidance given in FCC KDB 248227. The base station simulator or test software was set up for the proper channels, transmitter power levels and transmit modes of operation.

The portable hand-held device was tested in the configurations stipulated in [1], [4] and [5]. The portable hand-held device was positioned into these configurations using the device holder supplied with the DASY4™ SAR measurement system. The default settings for the “coarse” and “cube” scans were chosen and used for measurements. The grid spacing of the coarse scan was set to 15 mm or less as shown in the SAR plots included in Appendices 2 through 4. Please refer to the DASY4™ manual for additional information on SAR scanning procedures and algorithms used.

The portable hand-held device model covered by this report has an internal battery that is not replaceable by the end user. This battery was used to do all of the SAR testing. The battery was charged prior to each test.

6.1 Body Test Results

The SAR results shown in tables 1 through 3 are maximum SAR values averaged over 1 gram of phantom tissue, to demonstrate compliance to [3] and also over 10 grams of phantom tissue, to demonstrate compliance to [6]. Also shown are the temperature of the simulated tissue after the test, the measured drift, the measured conducted output power levels, power reduction amount (when applicable), the measured SAR corrected for probe calibration (when applicable), and the extrapolated SAR. The exact method of extrapolation is:

$$\text{Extrapolated SAR} = (\text{Measured or Corrected SAR}) * 10^{(-\text{drift}/10)}$$

The SAR reported at the end of the measurement process by the DASY4™ measurement system can be scaled up by the measured drift to determine the SAR at the beginning of the measurement process. This is the most conservative SAR because it corresponds to the average output power at the beginning of the SAR test. This extrapolation has been done because when the DUT is operating properly it may exhibit a slump in radiated power and SAR over time. This is verified by measuring the SAR drift after the test.

The requisite test positions for the DUT were chosen per the guidance provided in FCC KDB 447498 D01. The DUT was tested with the back surface of the device facing the phantom with no separation for all transmitters requiring test. Additionally, the DUT was tested with the back surface of the device at an appropriate separation from the phantom to capture compliance at the worst-case proximity sensor trigger point (i.e. the closest the DUT might come to a user without utilizing a set of reduced maximum power limits). The DUT was also tested along the edges of the device in which an antenna is located within 5 cm of that edge. Pictorial representation of the antenna locations and separation distances are given in section 1 above. Additionally, the software within the DUT was set to invert the orientation results from the DUT's sensor. E.g., the DUT "top edge" facing up (away from the body) was operating instead at the "top edge" facing down (toward the body) performance levels. This inversion of the orientation ensures proper exposure conditions were measured for SAR testing of an edge using the standard DASY4 measurement setup.

Table 3 presents SAR measurement results at a minimum separation distance in which the proximity sensor may deactivate the power reduction.

The test conditions that produced the highest SAR values in each band are indicated as bold numbers in the following tables and are included in Appendix 2. All other test conditions measured lower SAR values than those included in Appendix 2.

The SAR measurements were performed using the SAM phantoms listed in section 3.1. Since the same phantoms and simulated tissue were used for the system accuracy verification and the device SAR measurements, the Z-axis scans included in Appendix 1 are applicable for verification of simulated tissue depth. The simulated tissue depth was verified to be 15.0 cm ± 0.5 cm for frequencies less than 3 GHz, or 10.0 cm ± 0.5 cm for frequencies greater than 3 GHz. The same device holder described in section 6 was used for positioning the DUT.

The following probe conversion factors were used on the E-Field probe(s) used for the body measurements:

Description	Serial Number	f (MHz)	Conversion Factor	Cal Cert pg #
E-Field Probe ES3DV3	3115	835	5.88	6 of 11
		1810	4.61	6 of 11
E-Field Probe ES3DV3	3184	835	6.10	6 of 11
		1810	4.90	6 of 11
		2450	4.33	6 of 11

Body, Top Edge of DUT 0 mm from Phantom															
f (MHz)	Mode	Battery/Accessory	Channel	Temp (°C)	Drift (dB)	DUT Power		10 g SAR value			1 g SAR value			Test Plot	
						Measured (dBm)	Power Reduction (dB)	Measured (W/kg)	Corrected (W/kg) ⁴	Extrapolated (W/kg)	Measured (W/kg)	Corrected (W/kg)	Extrapolated (W/kg)	Grid	Plot Page
850	GPRS 850, Class 10	Internal	128	20.3	-0.0201	28.40	3.0	0.231	0.23	0.23	0.47	0.47	0.47	5x5x7	43
			190	20.3	-0.272	28.55	3.0	0.563	0.56	0.60	1.16	1.16	1.23		
			251	20.3	-0.153	28.53	3.0	0.539	0.54	0.56	1.10	1.10	1.14		
	4132														
	4180		19.7	-0.0686	21.27	2.6	0.346	0.35	0.35	0.669	0.67	0.68	5x5x7	44	
1880	GPRS 1900, Class 10	Internal	512	18.8	-0.285	24.82	5.0	0.490	0.49	0.52	1.14	1.14	1.22	5x5x7	45
			661	18.8	-0.145	24.93	5.0	0.502	0.50	0.52	1.18	1.18	1.22		
			810	18.8	-0.146	24.83	5.0	0.534	0.53	0.55	1.29	1.29	1.33		
	9262		20.1	-0.202	17.95	6.0	0.325	0.33	0.34	0.751	0.75	0.79	5x5x7	46	
	9400		20.1	-0.183	17.89	6.0	0.561	0.56	0.59	1.31	1.31	1.37			
9538	20.1	-0.0912	18.01	6.0	0.356	0.36	0.36	0.85	0.85	0.87	5x5x7	47			
2450	802.11b, 1 Mbps	1	20.0	-0.0589	13.18	13.18	0.157	0.16	0.16	0.365			0.37	0.37	
6															
11															

Table 1: SAR measurement results at the highest possible output power, measured in a body adjacent position against the ICNIRP and ANSI SAR Limit.

Body, Back Surface of DUT 0 mm from Phantom															
f (MHz)	Mode	Battery/Accessory	Channel	Temp (°C)	Drift (dB)	DUT Power		10 g SAR value			1 g SAR value			Test Plot	
						Measured (dBm)	Power Reduction (dB)	Measured (W/kg)	Corrected (W/kg)	Extrapolated (W/kg)	Measured (W/kg)	Corrected (W/kg)	Extrapolated (W/kg)	Grid	Plot Page
850	GPRS 850, Class 10	Internal	128	20.2	0.0553	25.90	5.5	0.365	0.37	0.37	0.660	0.66	0.66	5x5x7	48
			190	20.2	0.202	26.05	5.5	0.472	0.47	0.47	0.853	0.85	0.85		
			251	20.3	0.0945	26.03	5.5	0.533	0.53	0.53	0.971	0.97	0.97		
	4132														
	4180		19.7	0.0997	17.67	6.2	0.378	0.38	0.38	0.683	0.68	0.68	5x5x7	49	
1880	GPRS 1900, Class 10	Internal	512												
			661	18.8	-0.0028	22.43	7.5	0.356	0.36	0.36	0.794	0.79	0.79	5x5x7	50
			810												
	9262		20.1	-0.0466	15.95	8.0	0.669	0.67	0.68	1.48	1.48	1.50	5x5x7	51	
	9400		20.1	0.0144	15.89	8.0	0.548	0.55	0.55	1.23	1.23	1.23	5x5x7	51	
9538	20.1	-0.12	16.01	8.0	0.384	0.38	0.37	0.831	0.83	0.85					

Table 2a: SAR measurement results at the highest possible output power, measured in a body adjacent position against the ICNIRP and ANSI SAR Limit.

Body, Back Surface of DUT 0 mm from Phantom (continued)															
f (MHz)	Mode	Battery/Accessory	Channel	Temp (°C)	Drift (dB)	DUT Power		10 g SAR value			1 g SAR value			Test Plot	
						Measured (dBm)	Power Reduction (dB)	Measured (W/kg)	Corrected (W/kg)	Extrapolated (W/kg)	Measured (W/kg)	Corrected (W/kg)	Extrapolated (W/kg)	Grid	Plot Page
2450	802.11b, 1 Mbps	Internal	1	20.2	-0.111	13.18		0.513		0.53	1.19		1.22		
			6	20.0	0.0459	13.17		0.532		0.53	1.25		1.25		
			11	20.0	0.0138	13.07		0.542		0.54	1.29		1.29		
	1		20.0	0.0732	14.26		0.594		0.59	1.39		1.39			
	802.11b, 5.5 Mbps		6	20.0	0.124	14.34		0.541		0.54	1.28		1.28		
			11	20.0	-0.148	14.03		0.527		0.55	1.24		1.28		
			1	20.0	-0.104	14.42		0.559		0.57	1.29		1.32		
	802.11b, 11 Mbps		6	20.0	-0.0501	14.23		0.535		0.54	1.25		1.26		
			11	20.0	0.0862	14.12		0.532		0.53	1.28		1.28		
			6	20.0	-0.208	13.71		0.533		0.58	1.24		1.30		
	802.11g, 6 Mbps		11	20.0	-0.0731	13.48		0.52		0.53	1.23		1.25		
			1	19.2	0.0261	13.46		0.575		0.58	1.36		1.36		
	802.11g, 9 Mbps		6	19.3	-0.295	13.55		0.519		0.56	1.24		1.33		
			11	19.3	0.0172	13.35		0.552		0.55	1.31		1.31		
			1	19.3	0.0904	13.47		0.557		0.57	1.31		1.31		
	802.11g, 12 Mbps		6	19.3	-0.139	13.58		0.551		0.57	1.30		1.34		
			1	19.3	0.0345	13.53		0.577		0.58	1.36		1.36		
	802.11g, 18 Mbps		6	19.3	-0.0105	13.59		0.52		0.52	1.23		1.23		
			11	19.3	-0.0143	13.33		0.498		0.50	1.21		1.21		
			1	19.3	-0.084	14.01		0.549		0.56	1.28		1.30		
	802.11g, 24 Mbps		6	19.3	0.0708	14.16		0.512		0.51	1.21		1.21		
			11	19.3	-0.291	13.76		0.49		0.52	1.17		1.25		
			1	19.3	0.184	13.95		0.554		0.55	1.31		1.31		
	802.11g, 36 Mbps		6	19.3	0.241	14.04		0.517		0.52	1.23		1.23		
			11	19.6	-0.0794	13.82		0.475		0.48	1.12		1.14		
			6	19.6	-0.129	13.43		0.507		0.52	1.19		1.23		
	802.11n, 7.2 Mbps		6	20.5	0.0626	13.54		0.513		0.51	1.20		1.20		
	802.11n, 21.7 Mbps		1	20.5	0.0768	13.83		0.60		0.60	1.42		1.42	5x5x7	52
			6	20.5	0.115	13.99		0.535		0.54	1.25		1.25		
			11	20.5	0.0835	13.79		0.459		0.46	1.09		1.09		
	802.11n, 43.3 Mbps		1	19.6	-0.0025	13.88		0.50		0.50	1.24		1.24		
			6	19.6	-0.104	14.06		0.487		0.50	1.17		1.20		
			11	19.6	-0.0702	13.82		0.465		0.47	1.17		1.19		
	802.11n, 6.5 Mbps		6	20.5	0.0324	13.43		0.519		0.52	1.21		1.21		
	802.11n, 13 Mbps		1	20.0	0.0687	13.46		0.574		0.57	1.37		1.37		
			1	20.0	-0.0432	13.53		0.574		0.58	1.35		1.36		
			6	20.0	0.0578	13.54		0.518		0.52	1.21		1.21		
	802.11n, 19.5 Mbps		11	20.0	0.0529	13.39		0.503		0.50	1.18		1.18		
			1	20.0	0.185	14.13		0.562		0.56	1.31		1.31		
			6	20.0	0.163	14.15		0.519		0.52	1.20		1.20		
	802.11n, 26 Mbps		11	19.6	-0.065	13.98		0.484		0.49	1.21		1.23		
			1	19.6	0.0725	13.91		0.545		0.55	1.33		1.33		
6		19.6	-0.0506	14.06		0.473		0.48	1.16		1.17				
802.11n, 39 Mbps	11	19.6	-0.073	13.80		0.482		0.49	1.20		1.22				

Table 2b: SAR measurement results at the highest possible output power, measured in a body adjacent position against the ICNIRP and ANSI SAR Limit.

Table 3 below present SAR measurement results at a minimum separation distance in which the proximity sensor may deactivate the power reduction.

Body, Back Surface of DUT 11 mm from Phantom															
f (MHz)	Mode	Battery/Accessory	Channel	Temp (°C)	Drift (dB)	DUT Power		10 g SAR value			1 g SAR value			Test Plot	
						Measured (dBm)	Power Reduction (dB)	Measured (W/kg)	Corrected (W/kg)	Extrapolated (W/kg)	Measured (W/kg)	Corrected (W/kg)	Extrapolated (W/kg)	Grid	Plot Page
850	GPRS 850, Class 10	Internal	128												
			190												
			251	19.8	-0.17	31.53	0.00	0.336	⊗	0.35	0.518	⊗	0.53	5x5x7	53
	4132														
	4180		19.1	-0.0437	23.87	0.00	0.191	⊗	0.19	0.298	⊗	0.30	5x5x7	54	
	4233														
1880	GPRS 1900, Class 10	Internal	512												
			661	20.1	-0.181	29.93	0.00	0.396	⊗	0.41	0.729	⊗	0.76	5x5x7	55
			810												
	9262		19.8	-0.452	23.95	0.00	0.125	⊗	0.14	0.22	⊗	0.24	5x5x7	56	
	9400														
	9538														

Table 3: SAR measurement results at the highest possible output power, measured in a body adjacent position against the ICNIRP and ANSI SAR Limit.

6.2 Evaluation of Simultaneous Transmitters

The necessity of stand-alone and simultaneous SAR testing was evaluated for the licensed and unlicensed transmitters of the device per FCC KDB 447498 D01, which refers to "SAR Evaluation Considerations for Handsets with Multiple Transmitters and Antennas" (FCC KDB 648474).

By device design the GSM / WCDMA transmitter may operate simultaneously with either the Wi-Fi 802.11 transmitter (as a mobile hotspot) or the Bluetooth transmitter. Only the 2.4 GHz WiFi mode is available for clients when operating in the Mobile Hotspot mode, the 5 GHz is not enabled via firmware.

The Bluetooth transmitter of the device under test can be excluded from stand-alone and simultaneous SAR evaluation, per the highlighted requirements from FCC KDB 648474, as follows:

1. The highest output conducted power measured for Bluetooth on the device under test is 6.07 mW [$\leq 12 \text{ mW}$]
2. The separation distance between the Bluetooth antenna and the main antenna is 5.7 cm [$\geq 2.5 \text{ cm}$]

For the transmitters requiring stand-alone SAR testing (GSM/WCDMA and Wi-Fi 802.11), the KDB guidelines direct that if the sum of the 1 g SAR measured for the simultaneously transmitting antennas is less than the SAR limit, SAR measurements for simultaneous transmission is not required. Further, if the SAR-to-peak-location separation ratio for two simultaneously transmitting antennas is less than 0.3 then SAR measurement for simultaneous transmission is likewise not required. Evaluations of the worst-case body simultaneous SAR summations and separation ratios are presented in the table below.

Evaluations for Simultaneous SAR								
Cellular Transmitter Mode	Wi-Fi Transmitter Mode	Configuration	Cellular Transmitter 1 g SAR Value (W/kg)	Wi-Fi Transmitter 1 g SAR Value (W/kg)	Summation 1 g SAR Value (W/kg)	SAR-to-peak-location Separation Ratio	Plot Page	Simultaneous Measurements Required?
GPRS 850, Class 10	Wi-Fi 2450 802.11n, 28.9 Mbps	Back Surface of DUT 0 mm from Phantom	0.97	1.42	>1.60	0.27	20	No
WCDMA 850, 12.2 kbps RMC			0.68	1.42	>1.60	0.24	21	No
GPRS 850, Class 10			0.79	1.42	>1.60	0.25	21	No
WCDMA 1900, 12.2 kbps RMC			1.50	1.42	>1.60	0.32	21	Yes
GPRS 850, Class 10	Wi-Fi 2450 802.11b, 1 Mbps	Top Edge of DUT 0 mm from Phantom	1.23	0.37	>1.60	0.17	22	No
WCDMA 850, 12.2 kbps RMC			0.68	0.37	1.05	N/A		N/A
GPRS 850, Class 10			1.33	0.37	>1.60	0.18	22	No
WCDMA 1900, 12.2 kbps RMC			1.37	0.37	>1.60	0.19	22	No

For the configuration noted, combined SAR measurements were required to determine the aggregate 1 g SAR. The results of these measurements are given in the table below, with additional SAR plots of the combined measurements provided in Appendix 3.

Additional SAR measurements for simultaneous transmission evaluation were performed for each of the single transmitters using an extended zoom scan. This extended zoom scan was created to encompass the zoom scan volumes that were found previously in each of the stand-alone transmit SAR tests. For these tests, the outer dimensions of the extended zoom scan were X = 128 mm, Y = 40 mm, Z = 30 mm with a step size of X = 8 mm, Y = 8 mm, and Z = 5 using a graded step size with a ratio of 1.5 resulting in the following step increments: 2 mm, 2.7 mm, 4.0 mm, 5.9 mm, 7.4 mm. The step sizes and arrangement of measurement points were chosen to comply with the guidance provided in FCC KDB 865664.

The location of these extended zoom scans was established by using X, Y grid offsets from the "Grid Reference Point" in DASY4.7. The results were then combined via the DASY4.7 Multi-Band Combiner feature. A comparison can be performed between the stand-alone measurements for each noted transmitter and the measurements provided for simultaneous transmission. The measurements were not performed sequentially and thus may show slightly different results due to a number of reasons including, but not limited to, measurement system performance, slight differences in DUT positioning, or variations in simulated tissue parameters.

Measurements for Simultaneous SAR							
Cellular Transmitter Mode	Wi-Fi Transmitter Mode	Configuration	Extrapolated Cellular Transmitter 1 g SAR Value (W/kg)	Extrapolated Wi-Fi Transmitter 1 g SAR Value (W/kg)	Simultaneous 1 g SAR Value (W/kg)	Test Plots	
						Grid	Plot Page
WCDMA 1900, 12.2 kbps RMC	Wi-Fi 2450 802.11n, 28.9 Mbps	Back Surface of DUT 0 mm from Phantom	1.38	1.23	1.38	17x6x7	

SPLSR Calculations using SPEAG Application note TN110209:

For the GPRS 850 and WiFi combination on back surface:

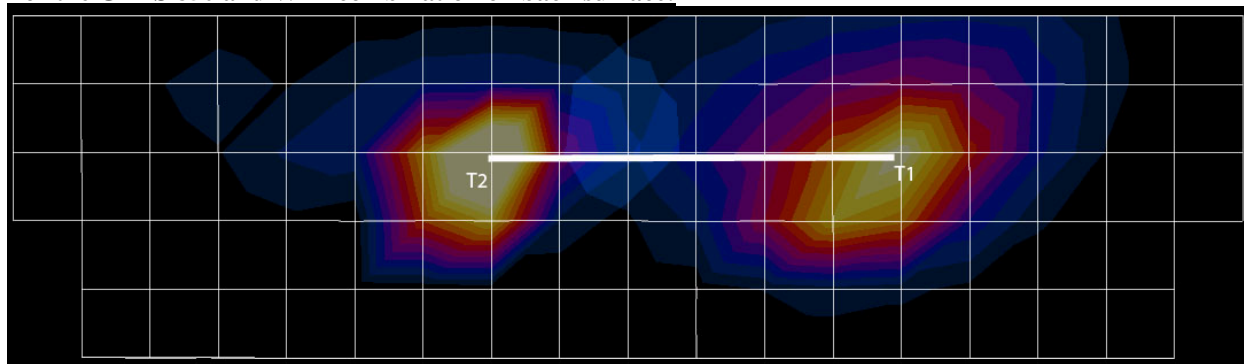

Peak SAR location for GPRS 850 (point T1) is (-0.0246, 0.054, -0.206)

Peak SAR location for WiFi (pont T2) is (-0.0245, -0.0345, -0.207)

Peak location spacing = 8.850571 cm

SPLSR = (0.97 + 1.42) / 8.850571 = 0.2700

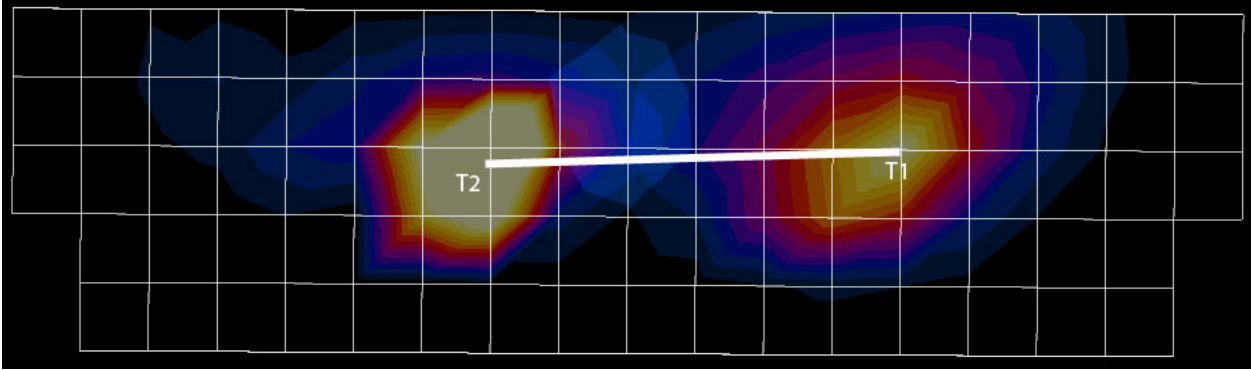
For the WCDMA 850 and WiFi combination on back surface:

Peak SAR location for WCDMA 850 (point T1) is (-0.0257, 0.0522, -0.206)

Peak SAR location for WiFi (point T2) is (-0.0245, -0.0345, -0.207)

Peak location spacing = 8.671407

SPLSR = $(0.68 + 1.42) / 8.671407 = 0.2422$ which has been rounded to 0.24 in the table above.

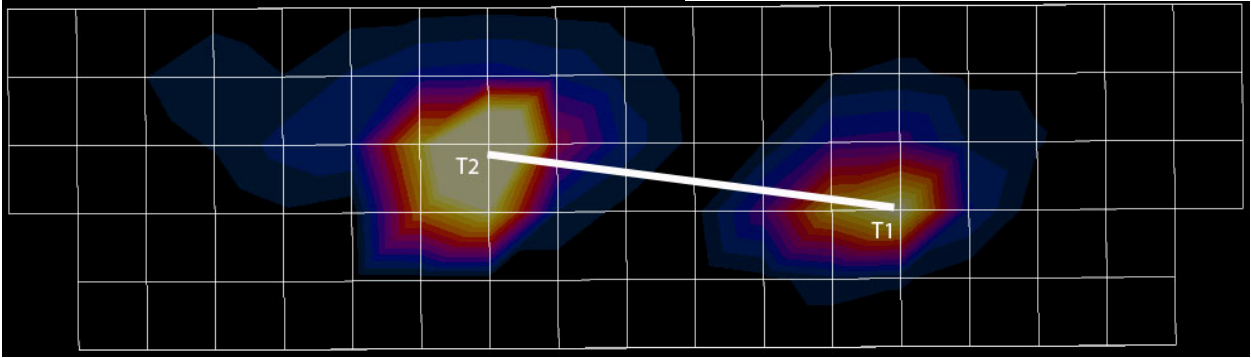
For the GPRS 1900 and WiFi combination on back surface:

Peak SAR location for GPRS 1900 (point T1) is (-0.02, 0.0555, -0.206)

Peak SAR location for WiFi (point T2) is (-0.0245, -0.0345, -0.207)

Peak location spacing = 9.011798

SPLSR = $(0.79 + 1.42) / 9.011798 = 0.245234$ which has been rounded to 0.25 in the table above.

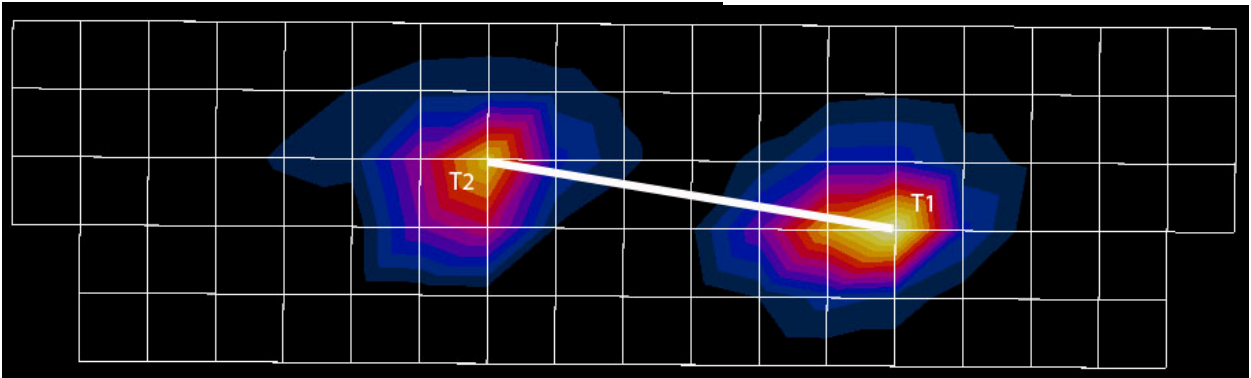
For the WCDMA 1900 and WiFi combination on back surface:

Peak SAR location for WCDMA 1900 (point T1) is (-0.0185, 0.057, -0.206)

Peak SAR location for WiFi (point T2) is (-0.0245, -0.0345, -0.207)

Peak location spacing = 9.020532

SPLSR = $(1.50 + 1.42) / 9.020532 = 0.32371$ which has been rounded to 0.32 in the table above.

For the GPRS 850 and WiFi combination on Top Edge:

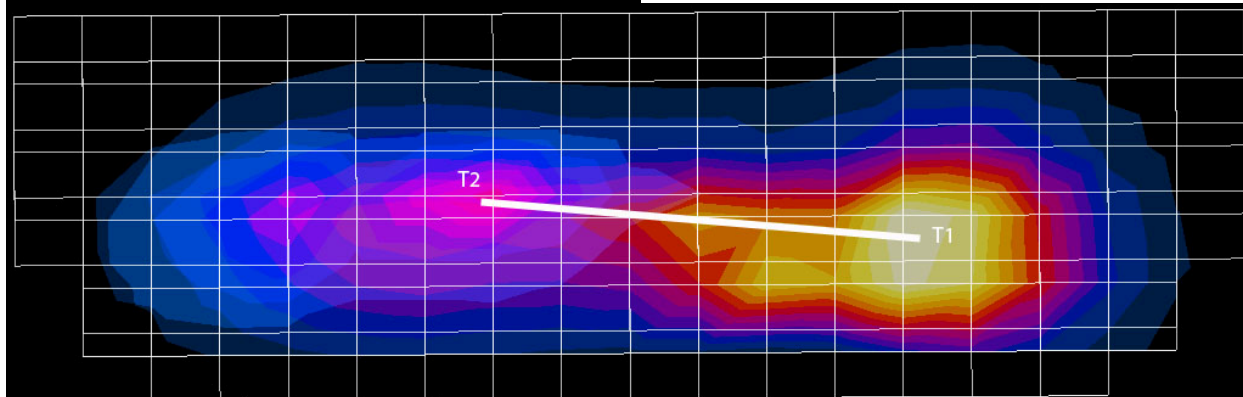

Peak SAR location for GPRS 850 (point T1) is (-0.00955, 0.0598, -0.206)
 Peak SAR location for WiFi (pont T2) is (-0.0189, -0.0347, -0207)
 Peak location spacing = 9.4967
 $SPLSR = (1.23 + 0.37) / 9.4967 = 0.1685$ which has been rounded to 0.17 in the table above.

For the GPRS 1900 and WiFi combination on Top Edge:

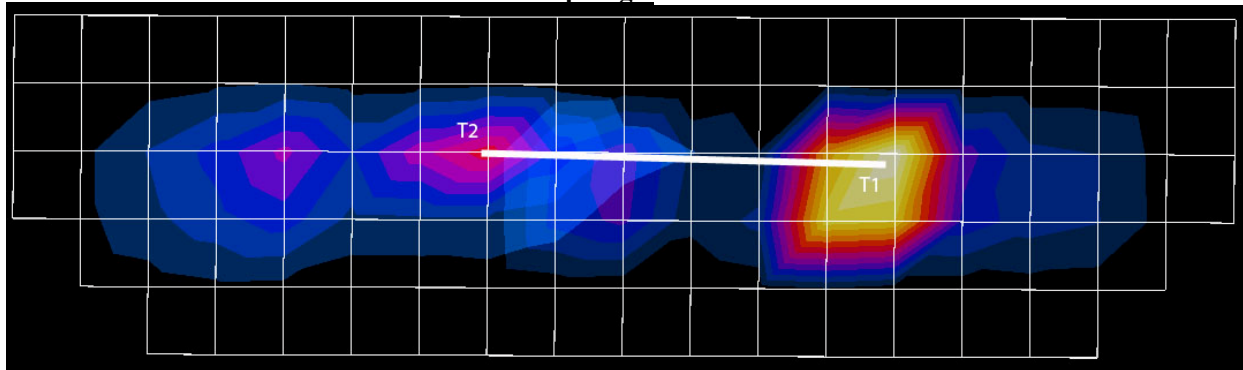

Peak SAR location for GPRS 1900 (point T1) is (-0.0145, 0.0573, -0.205)
 Peak SAR location for WiFi (pont T2) is (-0.0189, -0.0347, -0207)
 Peak location spacing = 9.212687
 $SPLSR = (1.33 + 0.37) / 9.212687 = 0.1845$ which has been rounded to 0.18 in the table above.

For the WCDMA 1900 and WiFi combination on Top Edge:

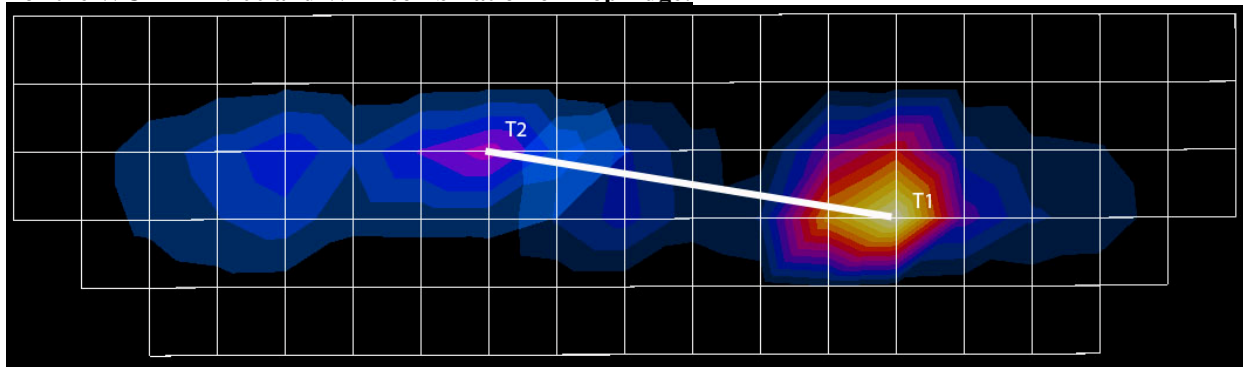

Peak SAR location for WCDMA 1900 (point T1) is (-0.0145, 0.0573, -0.205)
 Peak SAR location for WiFi (pont T2) is (-0.0189, -0.0347, -0207)
 Peak location spacing = 9.3707
 $SPLSR = (1.37 + 0.37) / 9.3707 = 0.1857$ which has been rounded to 0.19 in the table above.

References

- [1] CENELEC, en62209-1:2006 “Human Exposure to Radio Frequency Fields From Hand - Held and Body - Mounted Wireless Communication Devices – Human Models, Instrumentation, and Procedures”
- [2] CENELEC, en50360:2001 “Product standard to demonstrate the compliance of mobile phones with the basic restrictions related to human exposure to electromagnetic fields (300 MHz – 3 GHz)”.
- [3] ANSI / IEEE, C95.1 1992 Edition “IEEE Standard for Safety Levels with Respect to Human Exposure to Radio Frequency Electromagnetic Fields, 3 kHz to 300 GHz”
- [4] FCC OET Bulletin 65 Supplement C 01-01
- [5] IEEE 1528 2003 Edition “IEEE Recommended Practice for Determining the Peak Spatial-Average Specific Absorption Rate (SAR) in the Human Head from Wireless Communications Devices: Measurement Techniques”
- [6] ICNIRP Guidelines “Guidelines for Limiting Exposure to Time-Varying Electric, Magnetic, and Electromagnetic Fields (up to 300 GHz)”

Appendix 1

SAR distribution comparison for the system accuracy verification

Test Laboratory: Motorola 835 MHz System Performance Check

DUT: Dipole 835 MHz; Type: D835V2; Serial: D835V2 - SN:422

Procedure Notes: PM1 Power = 200 mW Refl.Pwr PM3 = -27.9dB [Sim.Temp@SPC](#) = 19.7°C Room Temp @ SPC = 21.2°C

Communication System: CW - Dipole; Frequency: 835 MHz; Duty Cycle: 1:1

Medium: Validation *BODY Tissue* ; Medium parameters used: $f = 835 \text{ MHz}$; $\sigma = 0.98 \text{ mho/m}$; $\epsilon_r = 55.6$; $\rho = 1000 \text{ kg/m}^3$

DASY4 Configuration:

- Probe: ES3DV3 - SN3115; ConvF(5.88, 5.88, 5.88); Calibrated: 1/12/2011
- Sensor-Surface: 4mm (Mechanical Surface Detection)
- Electronics: DAE3 Sn434; Calibrated: 1/13/2011
- Phantom: R#-6 Glycol SAM (extended range), Rev.1 (25-Mar-05); Type: SAM v4.0; Serial: TP-1131;
- Measurement SW: DASY4, V4.7 Build 80; Postprocessing SW: SEMCAD, V1.8 Build 186

Daily SPC Check/Dipole Area Scan (5x15x1): Measurement grid: dx=10mm, dy=15mm

Maximum value of SAR (measured) = 2.11 mW/g

Daily SPC Check/0-Degree, 5x5x7 Cube (5x5x7)/Cube 0: Measurement grid: dx=8mm, dy=8mm, dz=5mm

Reference Value = 47.3 V/m; Power Drift = -0.008 dB

Peak SAR (extrapolated) = 2.83 W/kg

SAR(1 g) = 1.96 mW/g; SAR(10 g) = 1.29 mW/g

Daily SPC Check/Z-Axis Retraction (1x1x31): Measurement grid: dx=20mm, dy=20mm, dz=5mm

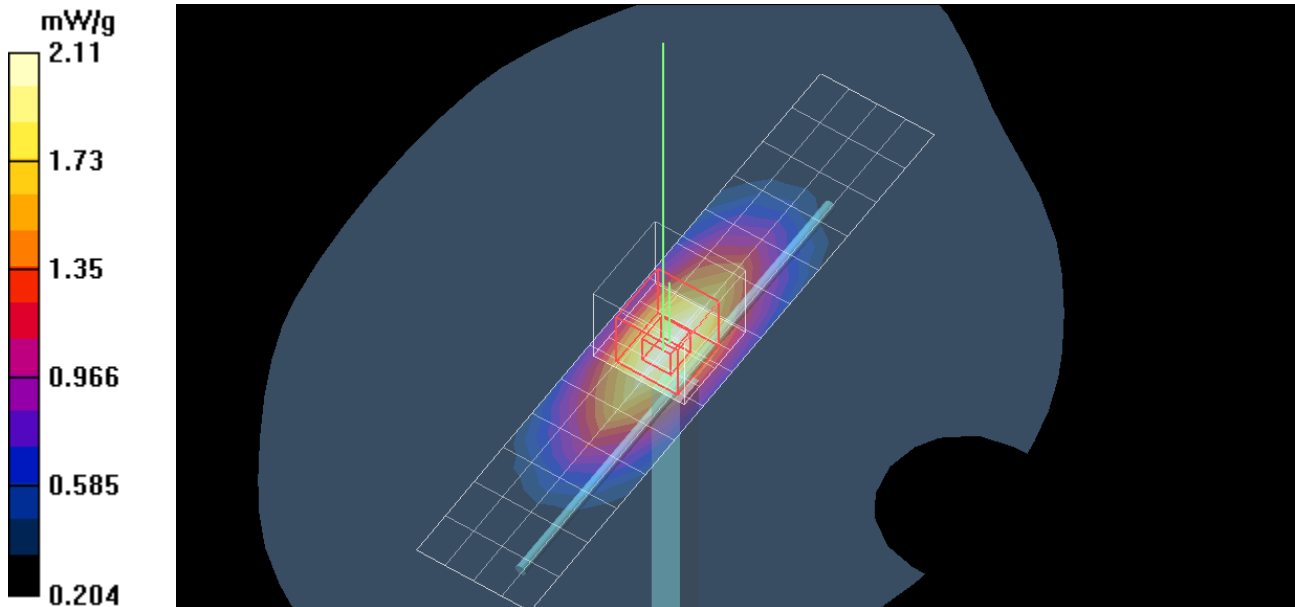

SAR(x,y,z,f0)

SAR; Z-Axis Retraction: Value Along Z, X=0, Y=0

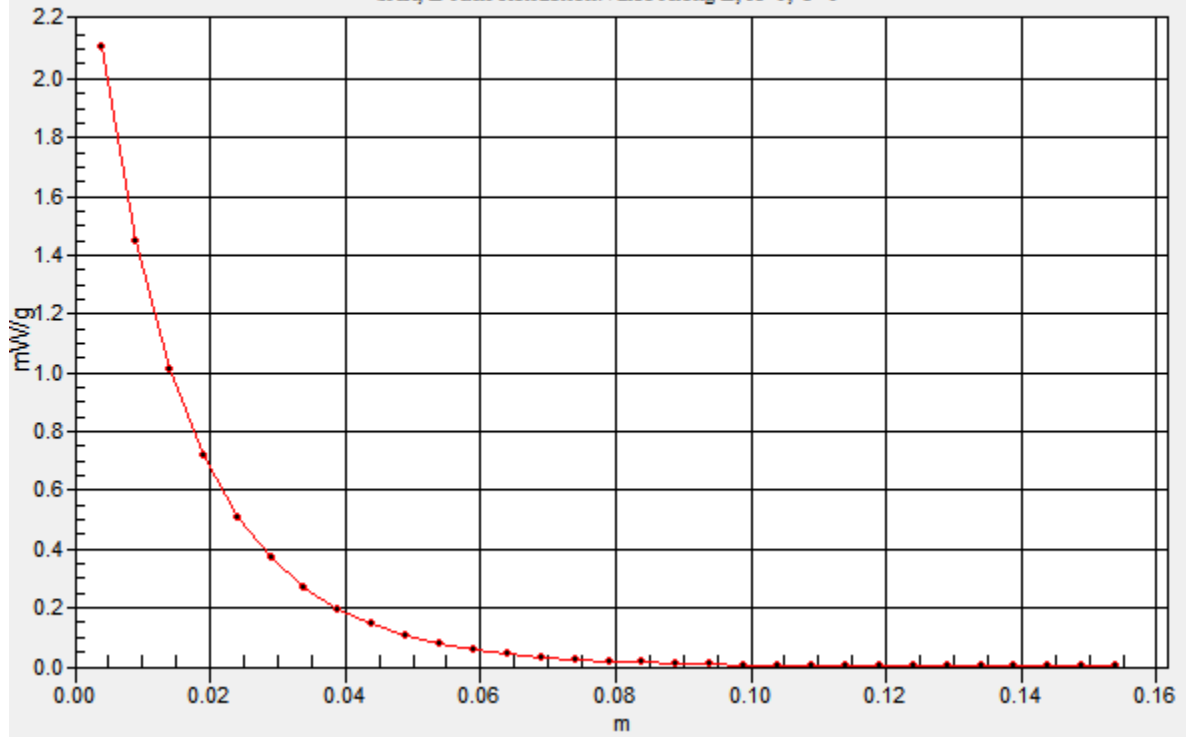

Test Laboratory: Motorola Mobility 835 MHz System Performance Check

DUT: Dipole 835 MHz; Type: D835V2; Serial: D835V2 - SN:436

Procedure Notes: PM1 Power = 200 mW Refl.Pwr PM3 = -20.7 dB [Sim.Temp@SPC](#) = 20.5 Room Temp @ SPC = 21.2

Communication System: CW - Dipole; Frequency: 835 MHz; Duty Cycle: 1:1

Medium: Validation *BODY Tissue* ; Medium parameters used: $f = 835 \text{ MHz}$; $\sigma = 0.99 \text{ mho/m}$; $\epsilon_r = 55.3$; $\rho = 1000 \text{ kg/m}^3$

DASY4 Configuration:

- Probe: ES3DV3 - SN3184; ConvF(6.1, 6.1, 6.1); Calibrated: 3/11/2011
- Sensor-Surface: 4mm (Mechanical Surface Detection)
- Electronics: DAE4 Sn702; Calibrated: 4/14/2011
- Phantom: R#2_ Section 2, Amy Twin, Rev3 (3-Feb-10); Type: Amy Twin Flat; Serial: n/a;
- Measurement SW: DASY4, V4.7 Build 80; Postprocessing SW: SEMCAD, V1.8 Build 186

Daily SPC Check/Dipole Area Scan (9x4x1): Measurement grid: $dx=15\text{mm}$, $dy=15\text{mm}$

Maximum value of SAR (measured) = 1.90 mW/g

Daily SPC Check/0-Degree 5x5x7 Cube (5x5x7)/Cube 0: Measurement grid: $dx=8\text{mm}$, $dy=8\text{mm}$, $dz=5\text{mm}$

Reference Value = 47.0 V/m; Power Drift = -0.017 dB

Peak SAR (extrapolated) = 2.92 W/kg

SAR(1 g) = 1.99 mW/g; SAR(10 g) = 1.31 mW/g

Maximum value of SAR (measured) = 2.14 mW/g

Daily SPC Check/Z-Axis Retraction (1x1x31): Measurement grid: $dx=20\text{mm}$, $dy=20\text{mm}$, $dz=5\text{mm}$

Maximum value of SAR (measured) = 2.15 mW/g

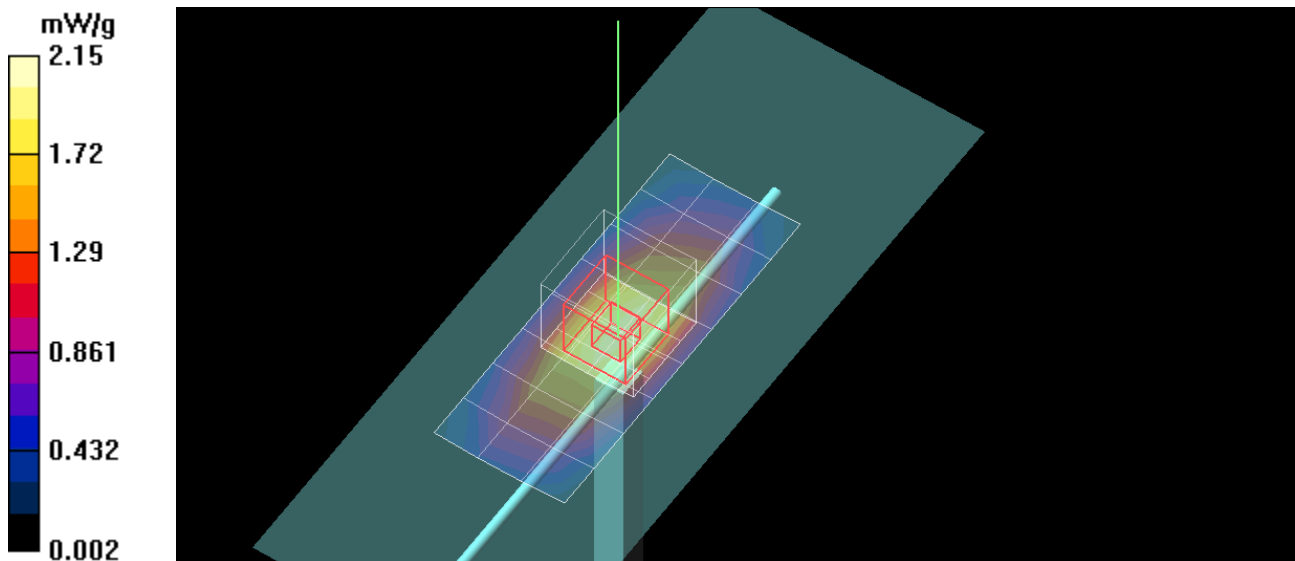

SAR(x,y,z,f0)

SAR; Z-Axis Retraction: Value Along Z, X=0, Y=0

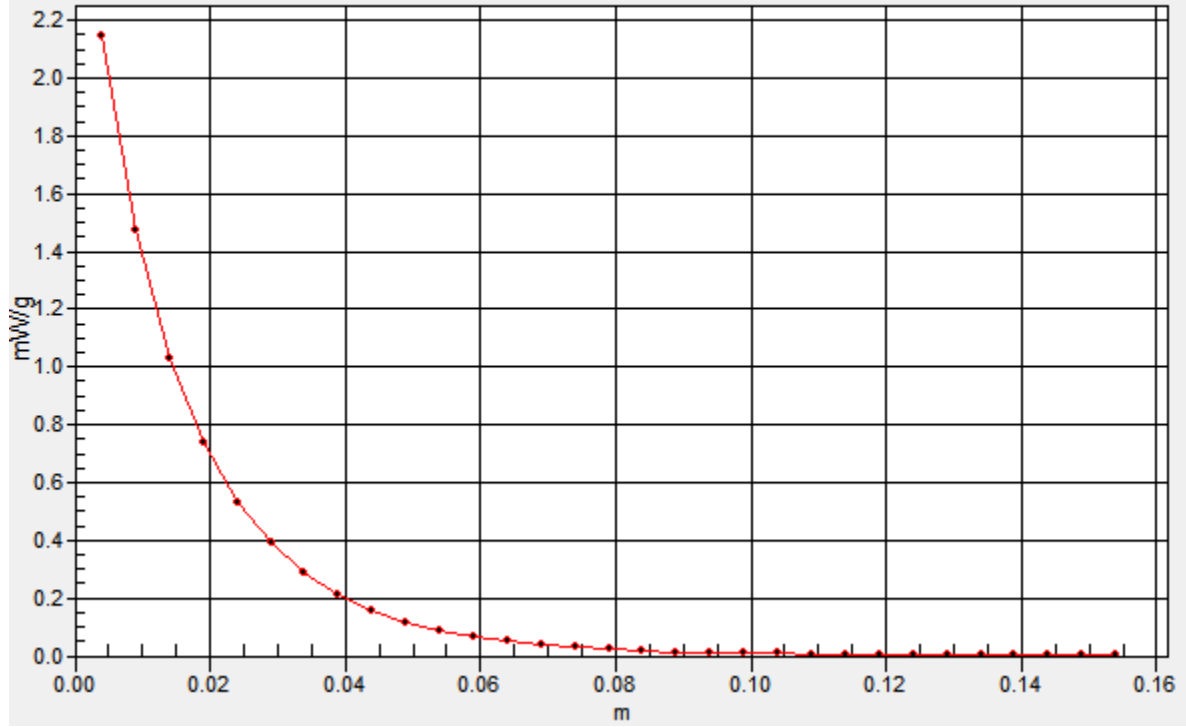

Test Laboratory: Motorola Mobility 1800 MHz System Performance Check

DUT: Dipole 1800 MHz; Type: D1800V2; Serial: D1800V2 - SN:250

Procedure Notes: PM1 Power = 200mW Refl.Pwr PM3 = -22.7dB [Sim.Temp@SPC](#) = 18.9°C Room Temp @ SPC = 19°C

Communication System: CW - Dipole; Frequency: 1800 MHz; Duty Cycle: 1:1

Medium: Validation *BODY Tissue* ; Medium parameters used: $f = 1800 \text{ MHz}$; $\sigma = 1.54 \text{ mho/m}$; $\epsilon_r = 51.2$; $\rho = 1000 \text{ kg/m}^3$

DASY4 Configuration:

- Probe: ES3DV3 - SN3115; ConvF(4.61, 4.61, 4.61); Calibrated: 1/12/2011
- Sensor-Surface: 4mm (Mechanical Surface Detection)
- Electronics: DAE3 Sn434; Calibrated: 1/13/2011
- Phantom: R#-6 Glycol SAM (extended range), Rev.1 (25-Mar-05); Type: SAM v4.0; Serial: TP-1131;
- Measurement SW: DASY4, V4.7 Build 80; Postprocessing SW: SEMCAD, V1.8 Build 186

Daily SPC Check/Dipole Area Scan (5x15x1): Measurement grid: dx=10mm, dy=15mm

Maximum value of SAR (measured) = 9.12 mW/g

Daily SPC Check/0-Degree, 5x5x7 Cube (5x5x7)/Cube 0: Measurement grid: dx=8mm, dy=8mm, dz=5mm

Reference Value = 79.5 V/m; Power Drift = -0.032 dB

Peak SAR (extrapolated) = 14.1 W/kg

SAR(1 g) = 8.17 mW/g; SAR(10 g) = 4.34 mW/g

Maximum value of SAR (measured) = 9.22 mW/g

Daily SPC Check/Z-Axis Retraction (1x1x31): Measurement grid: dx=20mm, dy=20mm, dz=5mm

Maximum value of SAR (measured) = 9.24 mW/g

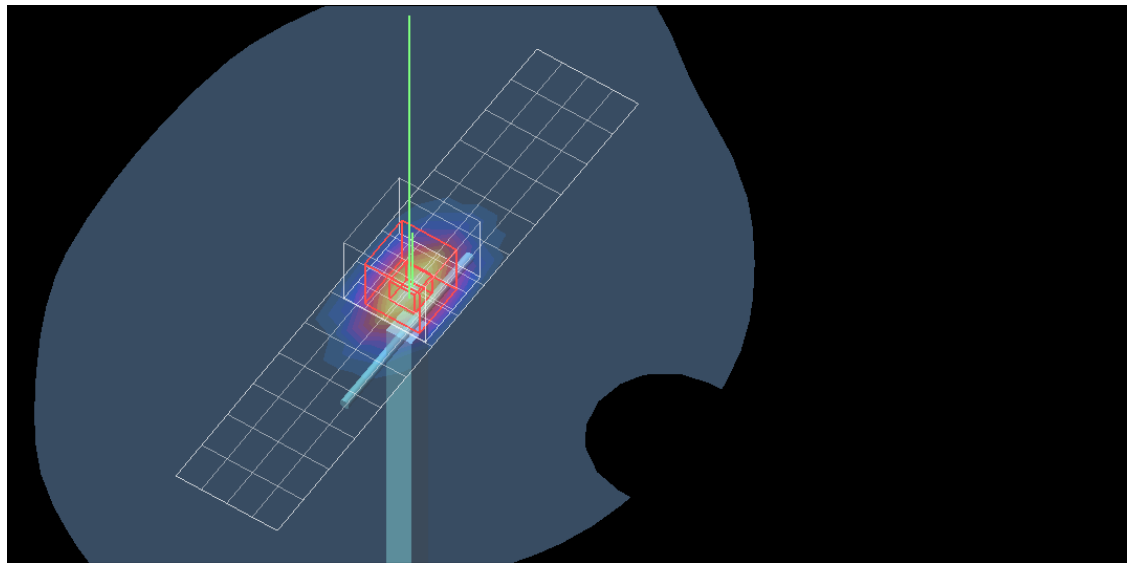
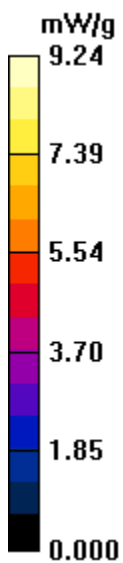

SAR(x,y,z,f0)

SAR; Z-Axis Retraction: Value Along Z, X=0, Y=0

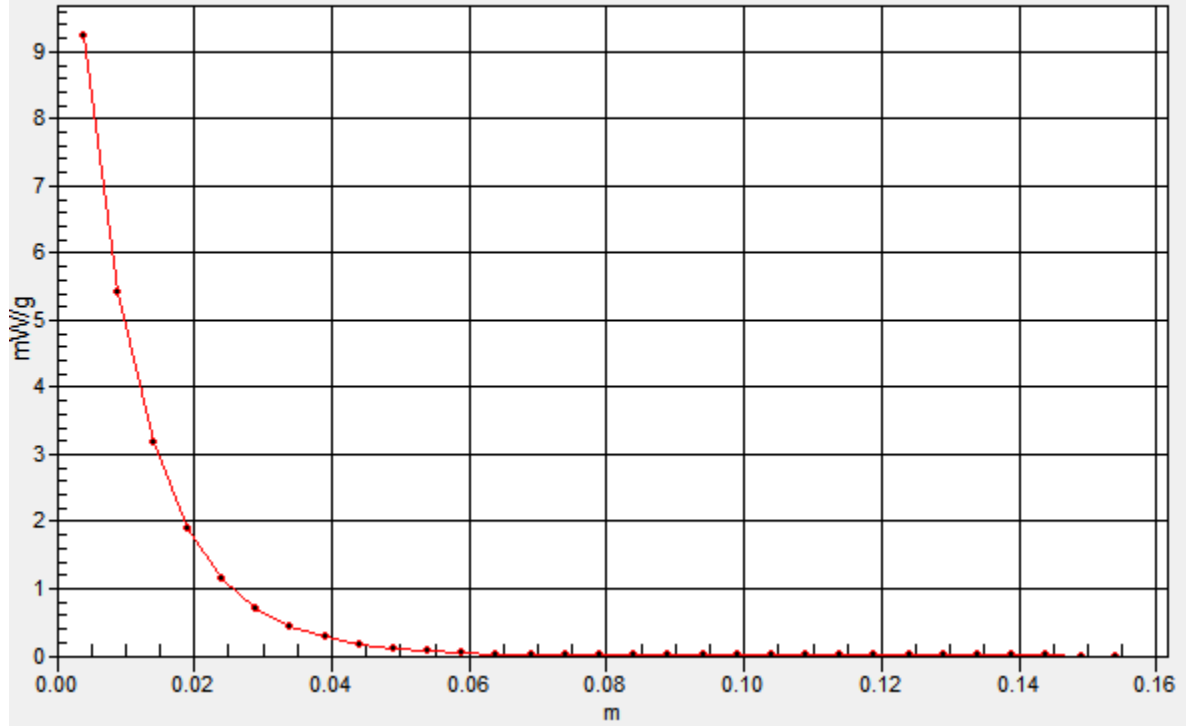

Test Laboratory: Motorola 1800 MHz System Performance Check

DUT: Dipole 1800 MHz; Type: D1800V2; Serial: D1800V2 - SN:250TR

Procedure Notes: PM1 Power = 200mW Refl.Pwr PM3 = -24.4dB Sim.Temp@SPC =20.5°C Room Temp @ SPC = 21.2°C

Communication System: CW - Dipole; Frequency: 1800 MHz;Duty Cycle: 1:1

Medium: Validation *BODY Tissue* ; Medium parameters used: $f = 1800 \text{ MHz}$; $\sigma = 1.47 \text{ mho/m}$; $\epsilon_r = 51.1$; $\rho = 1000 \text{ kg/m}^3$

DASY4 Configuration:

- Probe: ES3DV3 - SN3115; ConvF(4.61, 4.61, 4.61); Calibrated: 1/12/2011
- Sensor-Surface: 4mm (Mechanical Surface Detection)
- Electronics: DAE3 Sn434; Calibrated: 1/13/2011
- Phantom: R#-6 Glycol SAM (extended range), Rev.1 (25-Mar-05); Type: SAM v4.0; Serial: TP-1131;
- Measurement SW: DASY4, V4.7 Build 80; Postprocessing SW: SEMCAD, V1.8 Build 186

Daily SPC Check/Dipole Area Scan (5x15x1): Measurement grid: dx=10mm, dy=15mm

Maximum value of SAR (measured) = 8.50 mW/g

Daily SPC Check/0-Degree, 5x5x7 Cube (5x5x7)/Cube 0: Measurement grid: dx=8mm, dy=8mm, dz=5mm

Reference Value = 78.9 V/m; Power Drift = -0.060 dB

Peak SAR (extrapolated) = 13.5 W/kg

SAR(1 g) = 7.9 mW/g; SAR(10 g) = 4.2 mW/g

Maximum value of SAR (measured) = 8.91 mW/g

Daily SPC Check/Z-Axis Retraction (1x1x31): Measurement grid: dx=20mm, dy=20mm, dz=5mm

Maximum value of SAR (measured) = 8.94 mW/g

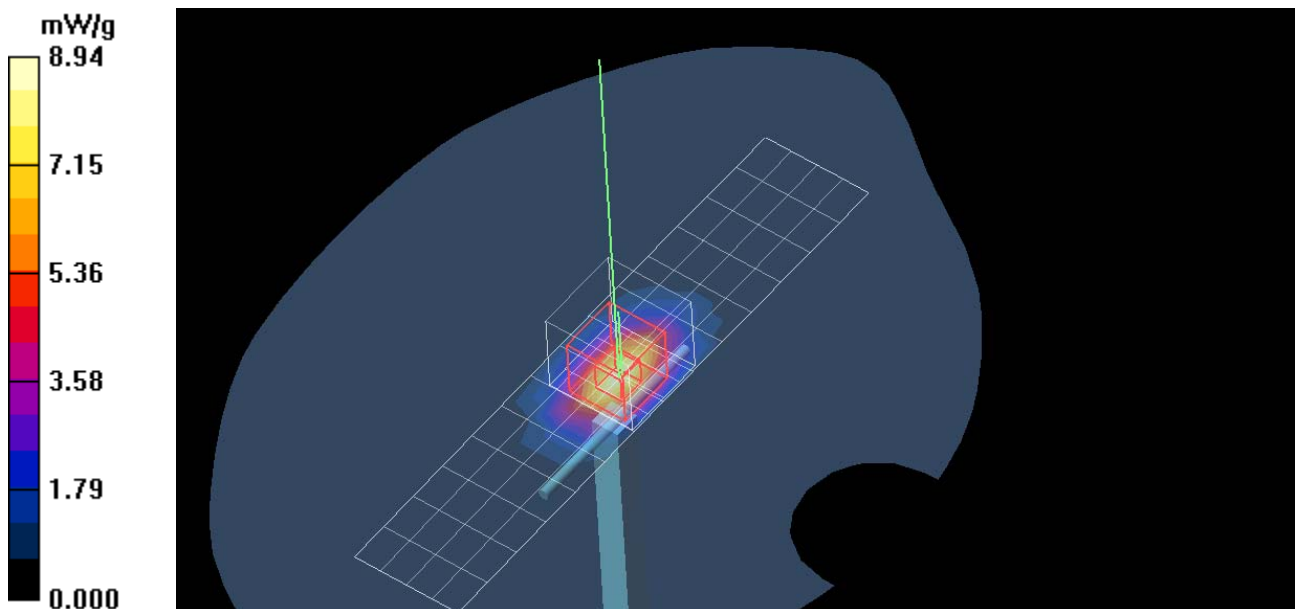

SAR(x,y,z,f0)

SAR; Z-Axis Retraction: Value Along Z, X=0, Y=0

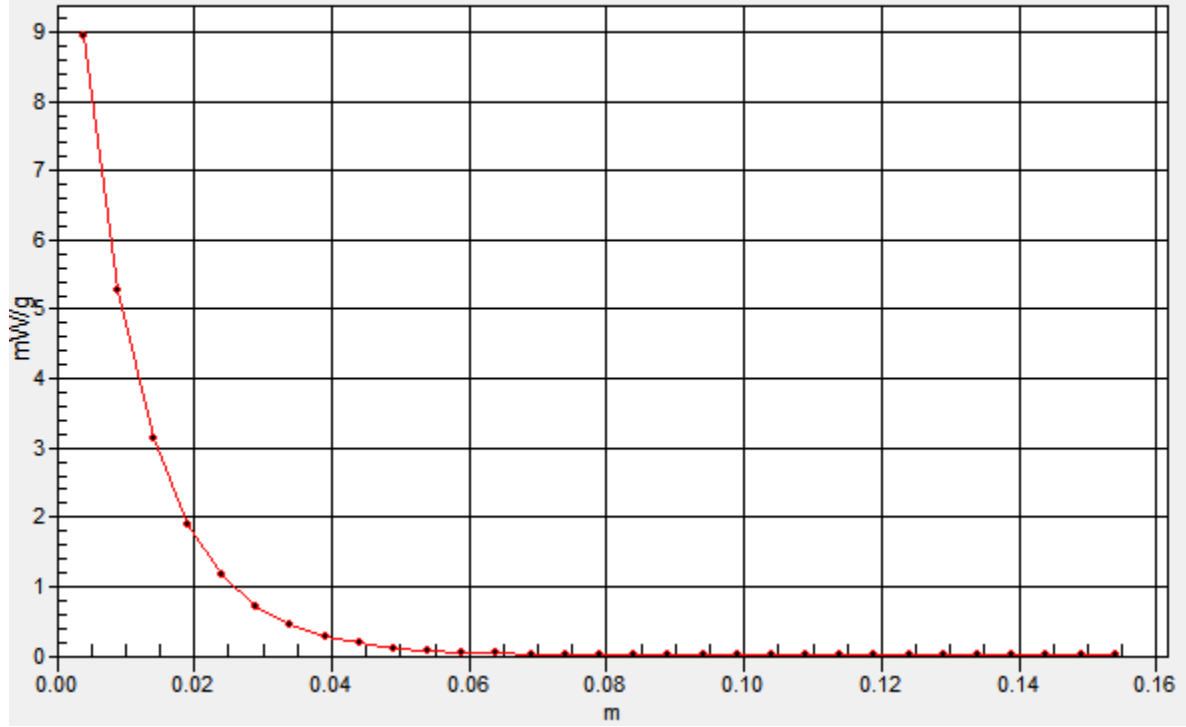

Test Laboratory: Motorola Mobility 1800 MHz System Performance Check

DUT: Dipole 1800 MHz; Type: D1800V2; Serial: D1800V2 - SN:271

Procedure Notes: PM1 Power = 200 mW Refl.Pwr PM3 = -20.65 dB [Sim.Temp@SPC](#) = 20.2°C Room Temp @ SPC = 21.1°C

Communication System: CW - Dipole; Frequency: 1800 MHz; Duty Cycle: 1:1

Medium: Validation *BODY Tissue* ; Medium parameters used: $f = 1800$ MHz; $\sigma = 1.48$ mho/m; $\epsilon_r = 51$; $\rho = 1000$ kg/m³

DASY4 Configuration:

- Probe: ES3DV3 - SN3184; ConvF(4.9, 4.9, 4.9); Calibrated: 3/11/2011
- Sensor-Surface: 4mm (Mechanical Surface Detection)
- Electronics: DAE4 Sn702; Calibrated: 4/14/2011
- Phantom: R#2_ Section 1, Amy Twin, Rev3 (3-Feb-10); Type: Amy Twin Flat; Serial: n/a;
- Measurement SW: DASY4, V4.7 Build 80; Postprocessing SW: SEMCAD, V1.8 Build 186

Daily SPC Check/Dipole Area Scan (9x4x1): Measurement grid: dx=15mm, dy=15mm

Maximum value of SAR (measured) = 6.45 mW/g

Daily SPC Check/0-Degree 5x5x7 Cube (5x5x7)/Cube 0: Measurement grid: dx=8mm, dy=8mm, dz=5mm

Reference Value = 78.0 V/m; Power Drift = -0.035 dB

Peak SAR (extrapolated) = 13.7 W/kg

SAR(1 g) = 7.81 mW/g; SAR(10 g) = 4.16 mW/g

Maximum value of SAR (measured) = 8.77 mW/g

Daily SPC Check/Z-Axis Retraction (1x1x31): Measurement grid: dx=20mm, dy=20mm, dz=5mm

Maximum value of SAR (measured) = 8.68 mW/g

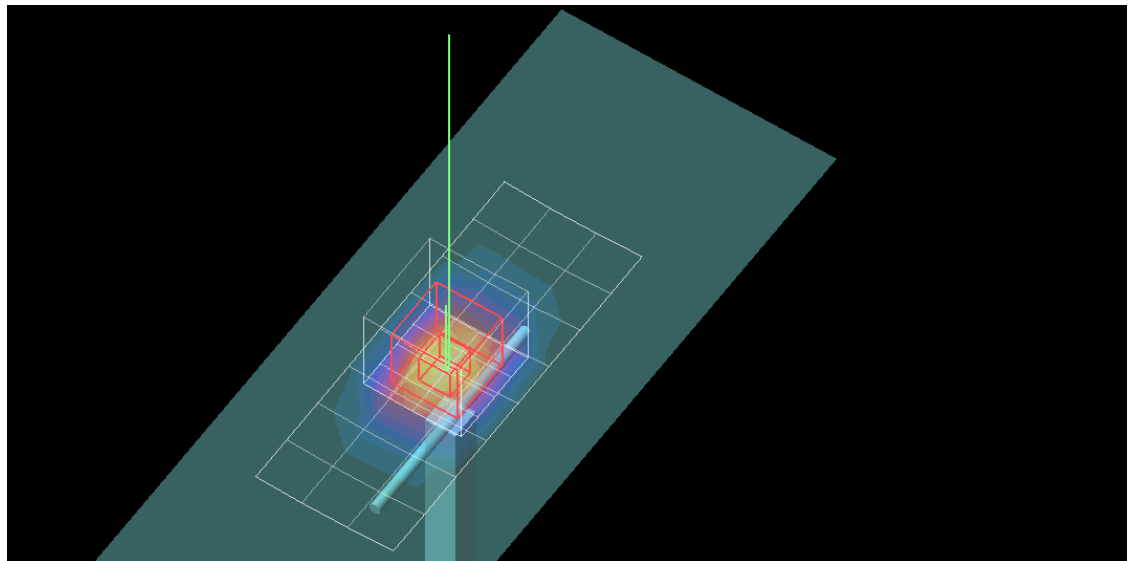
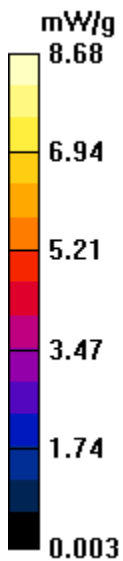

SAR(x,y,z,f0)

SAR; Z-Axis Retraction: Value Along Z, X=0, Y=0

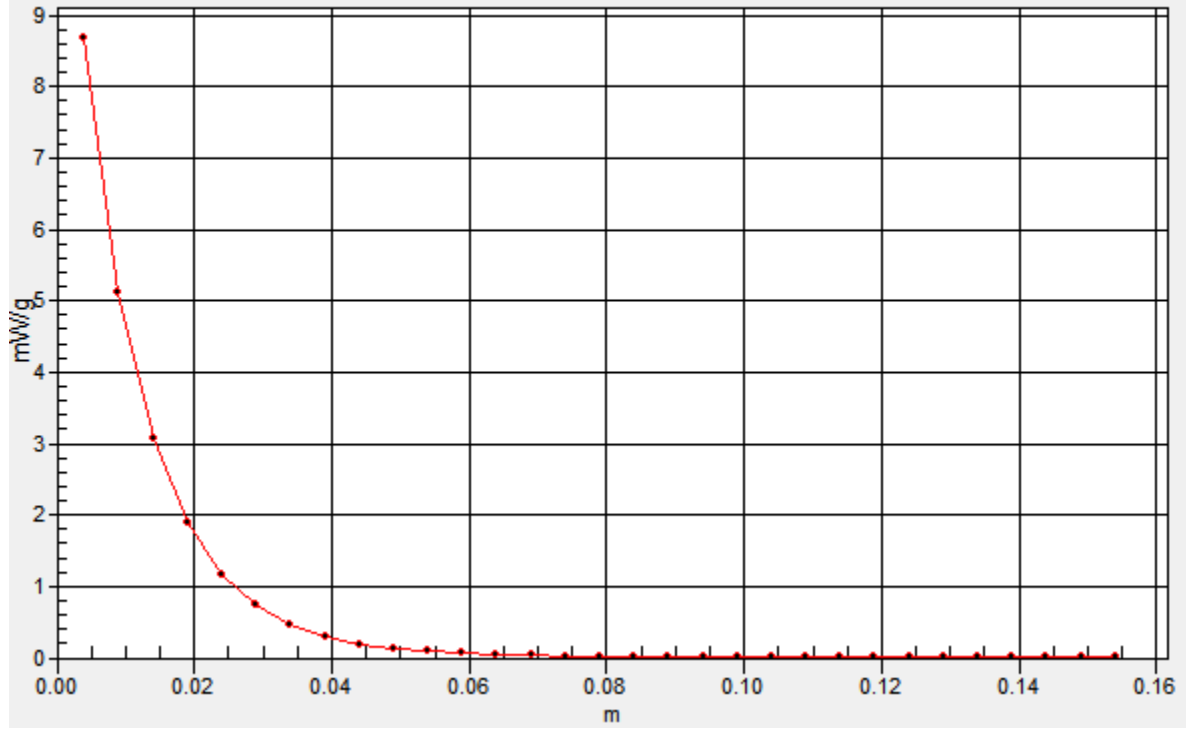

Test Laboratory: Motorola Mobility 1800 MHz System Performance Check

DUT: HAC Dipole 1880 MHz; Type: D1880V2; Serial: 259

Procedure Notes: PM1 Power = 200 mW Refl.Pwr PM3 = -19.53 dB [Sim.Temp@SPC](#) = 20 Room Temp @ SPC = 21.4

Communication System: CW - Dipole; Frequency: 1800 MHz; Duty Cycle: 1:1

Medium: Validation *BODY Tissue* ; Medium parameters used: $f = 1800$ MHz; $\sigma = 1.49$ mho/m; $\epsilon_r = 51.4$; $\rho = 1000$ kg/m³

DASY4 Configuration:

- Probe: ES3DV3 - SN3184; ConvF(4.9, 4.9, 4.9); Calibrated: 3/11/2011
- Sensor-Surface: 4mm (Mechanical Surface Detection)
- Electronics: DAE4 Sn702; Calibrated: 4/14/2011
- Phantom: R#2 Glycol SAM (extended range), Rev.1 (25-Mar-05); Type: SAM v4.0; Serial: TP-1136;
- Measurement SW: DASY4, V4.7 Build 80; Postprocessing SW: SEMCAD, V1.8 Build 186

Daily SPC Check/Dipole Area Scan (5x15x1): Measurement grid: dx=10mm, dy=15mm

Maximum value of SAR (measured) = 8.20 mW/g

Daily SPC Check/0-Degree, 5x5x7 Cube (5x5x7)/Cube 0: Measurement grid: dx=8mm, dy=8mm, dz=5mm

Reference Value = 71.9 V/m; Power Drift = 0.039 dB

Peak SAR (extrapolated) = 13.3 W/kg

SAR(1 g) = 7.57 mW/g; SAR(10 g) = 4.05 mW/g

Maximum value of SAR (measured) = 8.47 mW/g

Daily SPC Check/Z-Axis Retraction (1x1x31): Measurement grid: dx=20mm, dy=20mm, dz=5mm

Maximum value of SAR (measured) = 8.52 mW/g

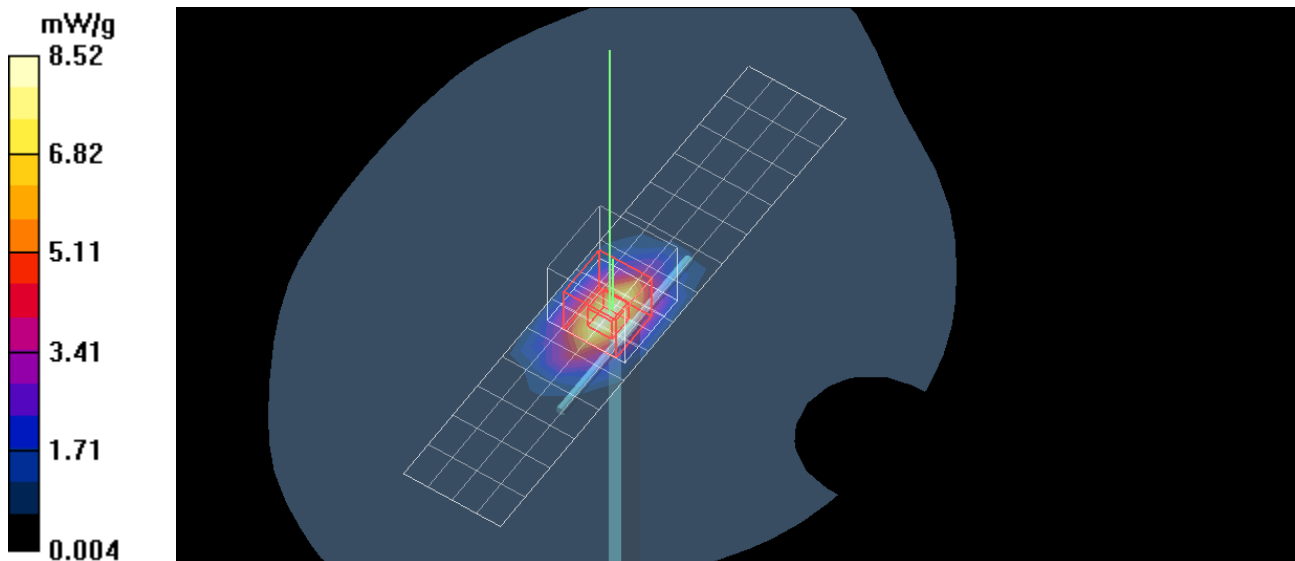

SAR(x,y,z,f0)

SAR; Z-Axis Retraction: Value Along Z, X=0, Y=0

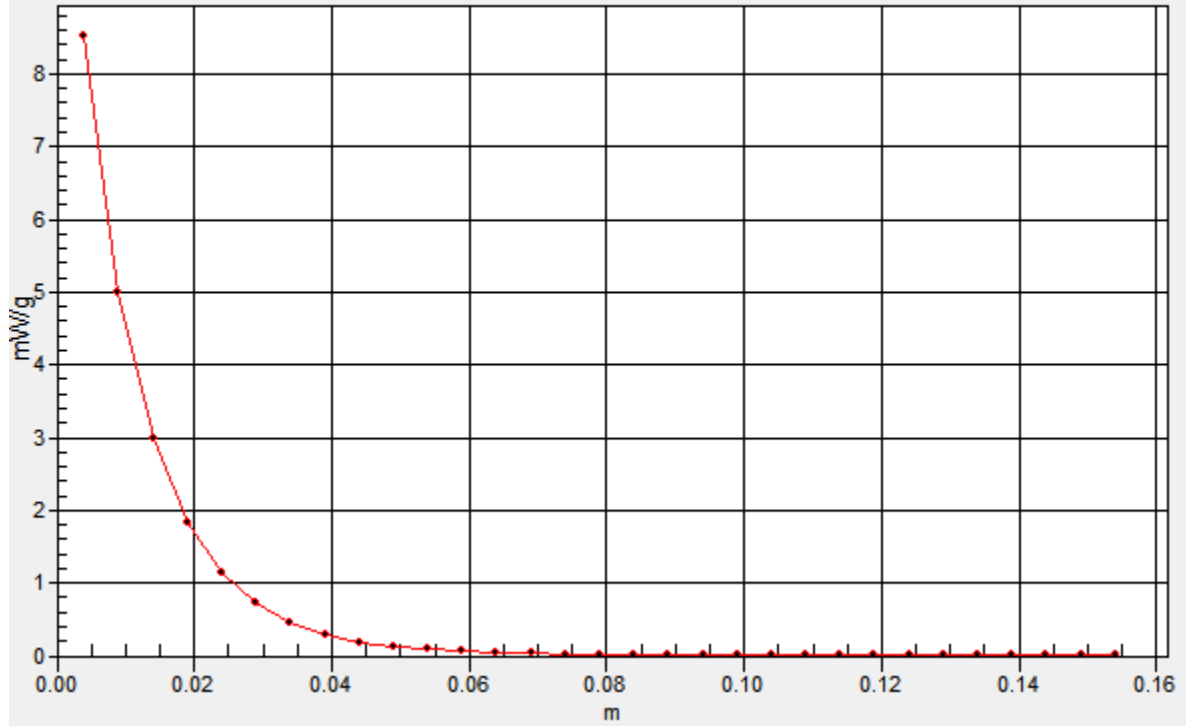

Test Laboratory: Motorola 2450 MHz System Performance Check

DUT: Dipole 2450 MHz; Type: D2450V2; Serial: D2450V2 - SN:766

Procedure Notes: PM1 Power =200 mW Refl.Pwr PM3 = -22.55B [Sim.Temp@SPC](#) = 20.5 Room Temp @ SPC = 21.2

Communication System: CW - Dipole; Frequency: 2450 MHz;Duty Cycle: 1:1

Medium: Validation *BODY Tissue* ; Medium parameters used: $f = 2450$ MHz; $\sigma = 1.92$ mho/m; $\epsilon_r = 51.6$; $\rho = 1000$ kg/m³

DASY4 Configuration:

- Probe: ES3DV3 - SN3184; ConvF(4.33, 4.33, 4.33); Calibrated: 3/11/2011
- Sensor-Surface: 4mm (Mechanical Surface Detection)
- Electronics: DAE4 Sn702; Calibrated: 4/14/2011
- Phantom: R#2 Glycol SAM (extended range), Rev.1 (25-Mar-05); Type: SAM v4.0; Serial: TP-1136;
- Measurement SW: DASY4, V4.7 Build 80; Postprocessing SW: SEMCAD, V1.8 Build 186

Daily SPC Check/Dipole Area Scan (5x15x1): Measurement grid: dx=10mm, dy=15mm

Maximum value of SAR (measured) = 9.68 mW/g

Daily SPC Check/0-Degree, 5x5x7 Cube (5x5x7)/Cube 0: Measurement grid: dx=8mm, dy=8mm, dz=5mm

Reference Value = 67.8 V/m; Power Drift = 0.103 dB

Peak SAR (extrapolated) = 19.7 W/kg

SAR(1 g) = 9.87 mW/g; SAR(10 g) = 4.65 mW/g

Maximum value of SAR (measured) = 11.3 mW/g

Daily SPC Check/Z-Axis Retraction (1x1x31): Measurement grid: dx=20mm, dy=20mm, dz=5mm

Maximum value of SAR (measured) = 11.2 mW/g

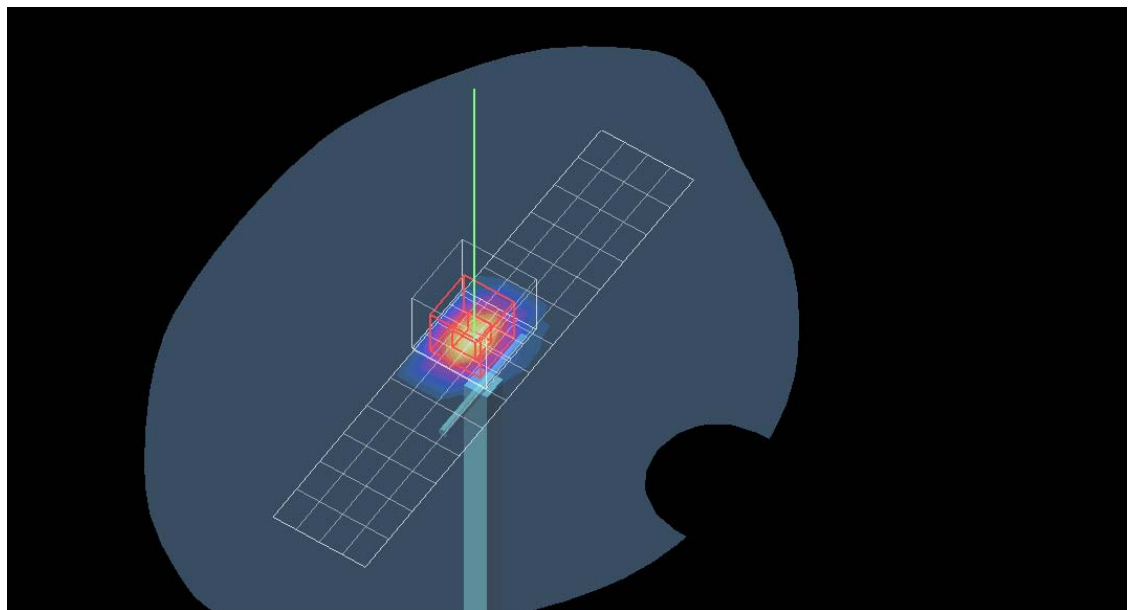
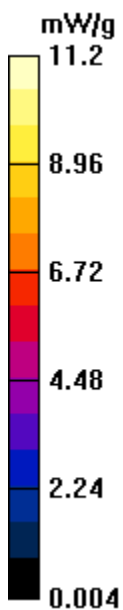

SAR(x,y,z,f0)

SAR; Z-Axis Retraction: Value Along Z, X=0, Y=0

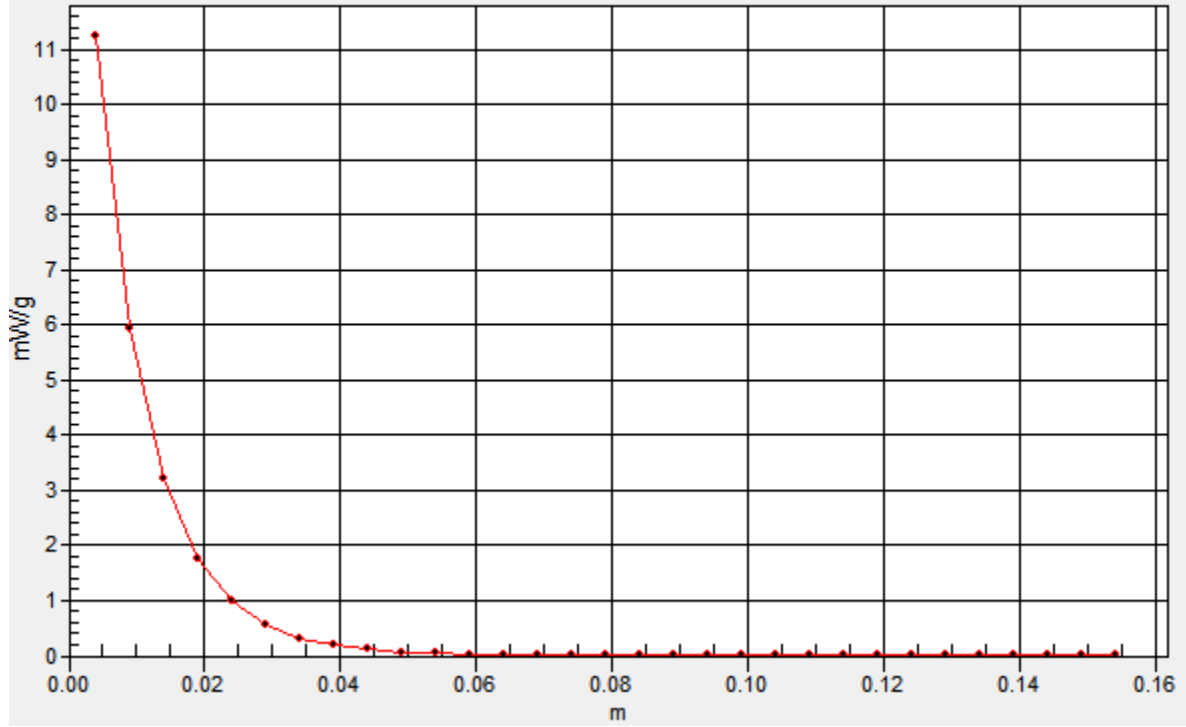

Test Laboratory: Motorola 2450 MHz System Performance Check

DUT: Dipole 2450 MHz; Type: D2450V2; Serial: D2450V2 - SN:740

Procedure Notes: PM1 Power = 200 mW Refl.Pwr PM3 = -24.2dB [Sim.Temp@SPC](#) = 20.2°C Room Temp @ SPC = 21.3°C

Communication System: CW - Dipole; Frequency: 2450 MHz; Duty Cycle: 1:1

Medium: Validation *BODY Tissue* ; Medium parameters used: $f = 2450 \text{ MHz}$; $\sigma = 1.92 \text{ mho/m}$; $\epsilon_r = 52$; $\rho = 1000 \text{ kg/m}^3$

DASY4 Configuration:

- Probe: ES3DV3 - SN3184; ConvF(4.33, 4.33, 4.33); Calibrated: 3/11/2011
- Sensor-Surface: 4mm (Mechanical Surface Detection)
- Electronics: DAE4 Sn702; Calibrated: 4/14/2011
- Phantom: R#2 Glycol SAM (extended range), Rev.1 (25-Mar-05); Type: SAM v4.0; Serial: TP-1136;
- Measurement SW: DASY4, V4.7 Build 80; Postprocessing SW: SEMCAD, V1.8 Build 186

Daily SPC Check/Dipole Area Scan (5x15x1): Measurement grid: dx=10mm, dy=15mm

Maximum value of SAR (measured) = 11.5 mW/g

Daily SPC Check/0-Degree, 5x5x7 Cube (5x5x7)/Cube 0: Measurement grid: dx=8mm, dy=8mm, dz=5mm

Reference Value = 78.8 V/m; Power Drift = -0.019 dB

Peak SAR (extrapolated) = 20.3 W/kg

SAR(1 g) = 10.2 mW/g; SAR(10 g) = 4.81 mW/g

Maximum value of SAR (measured) = 11.2 mW/g

Daily SPC Check/Z-Axis Retraction (1x1x31): Measurement grid: dx=20mm, dy=20mm, dz=5mm

Maximum value of SAR (measured) = 11.6 mW/g

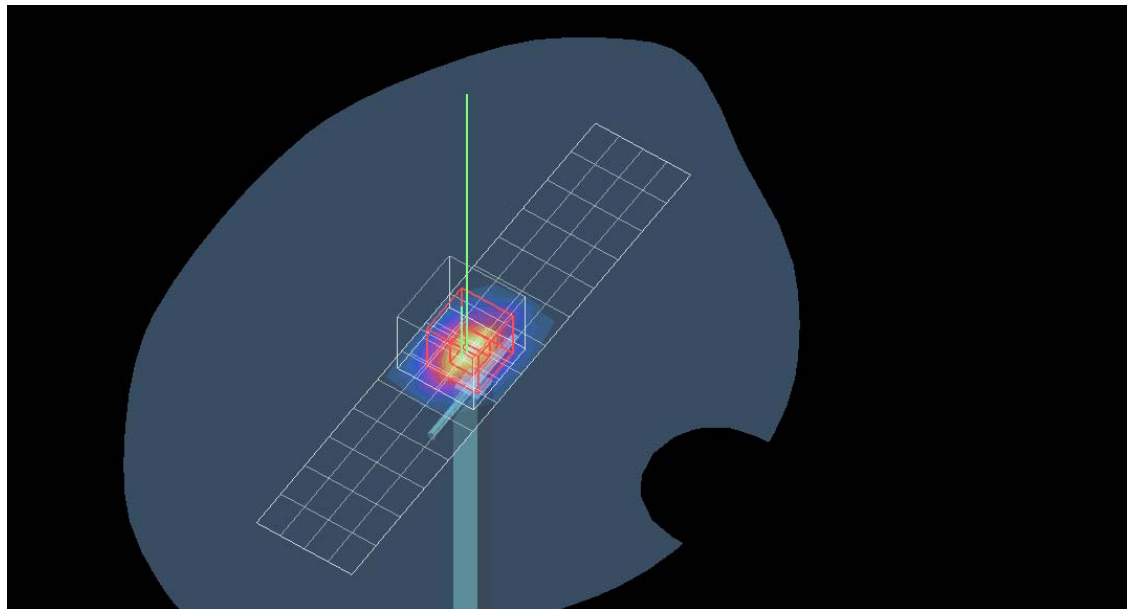
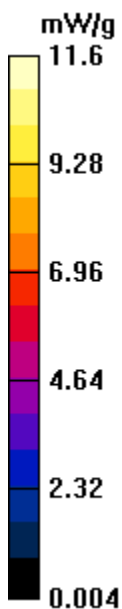

SAR(x,y,z,f0)

SAR; Z-Axis Retraction: Value Along Z, X=0, Y=0

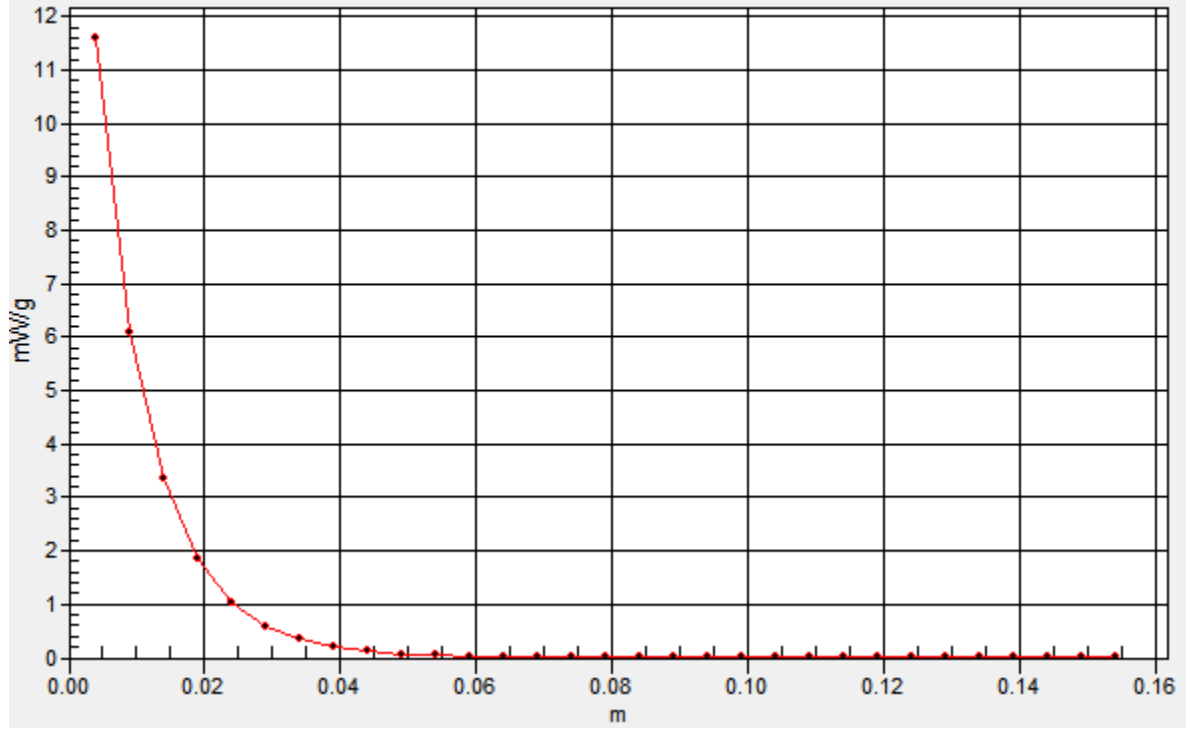

Appendix 2

SAR distribution plots for Body Configuration

Test Laboratory: Motorola Mobility GPRS 850 - Top Edge

DUT: Serial: KPUA020375, FCC ID: IHDP56MF2

Procedure Notes: Pwr Step: 5 Battery Model #: INTERNAL Test Configuration = Top Edge 0mm from Phantom Communication System: GPRS 850 - Class 10; Frequency: 836.6 MHz; Duty Cycle: 1:4.15

Medium: big body; Medium parameters used: $f = 835$ MHz; $\sigma = 0.98$ mho/m; $\epsilon_r = 55.6$; $\rho = 1000$ kg/m³

DASY4 Configuration:

- Probe: ES3DV3 - SN3115; ConvF(5.88, 5.88, 5.88); Calibrated: 1/12/2011
- Sensor-Surface: 4mm (Mechanical Surface Detection)
- Electronics: DAE3 Sn434; Calibrated: 1/13/2011
- Phantom: R#-6 Glycol SAM (extended range), Rev.1 (25-Mar-05); Type: SAM v4.0; Serial: TP-1131;
- Measurement SW: DASY4, V4.7 Build 80; Postprocessing SW: SEMCAD, V1.8 Build 186

SAM Phone Against Flat Section/Tablet Partial Face (front/back) Area Scan - Normal Body

(15mm) (21x6x1): Measurement grid: dx=15mm, dy=15mm

Maximum value of SAR (measured) = 0.753 mW/g

SAM Phone Against Flat Section/5x5x7 Zoom Scan (<=3GHz) (5x5x7)/Cube 0: Measurement grid:

dx=8mm, dy=8mm, dz=5mm

Reference Value = 19.6 V/m; Power Drift = -0.272 dB

Peak SAR (extrapolated) = 2.73 W/kg

SAR(1 g) = 1.16 mW/g; SAR(10 g) = 0.563 mW/g

Maximum value of SAR (measured) = 1.43 mW/g

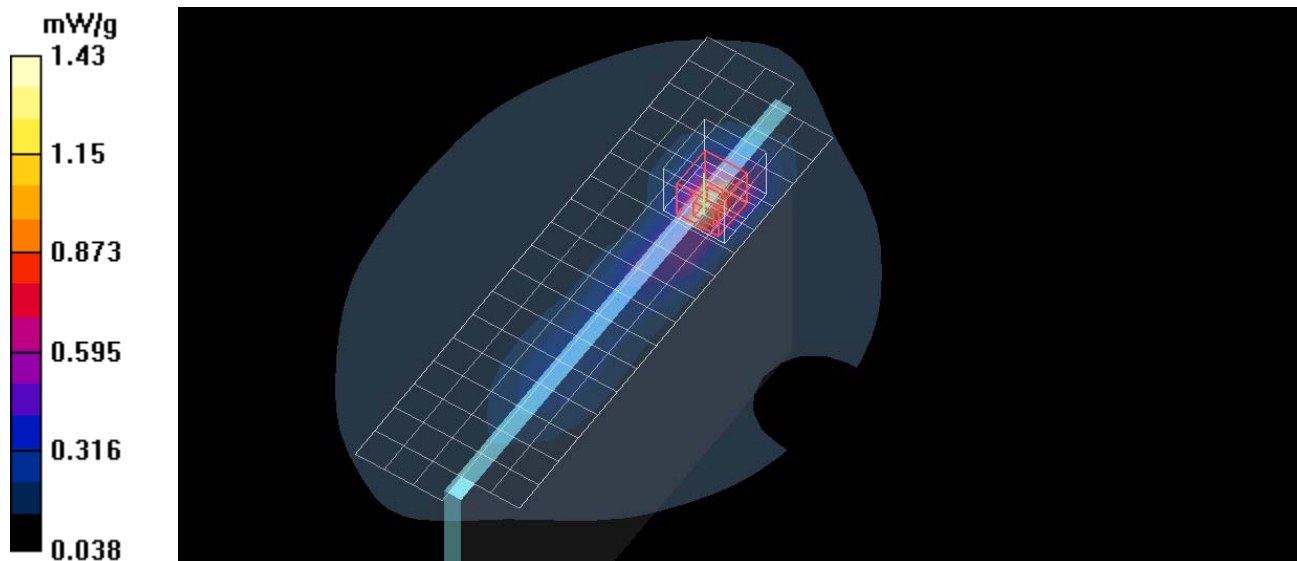

Test Laboratory: Motorola Mobility - WCDMA 850 - Top Edge

DUT: Serial: KPUA020375, FCC ID: IHDP56MF2

Procedure Notes: Pwr Step: always up Battery Model #: INTERNAL Test Configuration = Top Edge 0mm from Phantom

Communication System: 3G-WCDMA 850; Frequency: 836 MHz; Duty Cycle: 1:1

Medium: big body; Medium parameters used: $f = 835$ MHz; $\sigma = 0.98$ mho/m; $\epsilon_r = 55.6$; $\rho = 1000$ kg/m³

DASY4 Configuration:

- Probe: ES3DV3 - SN3115; ConvF(5.88, 5.88, 5.88); Calibrated: 1/12/2011
- Sensor-Surface: 4mm (Mechanical Surface Detection)
- Electronics: DAE3 Sn434; Calibrated: 1/13/2011
- Phantom: R#-6 Glycol SAM (extended range), Rev.1 (25-Mar-05); Type: SAM v4.0; Serial: TP-1131;
- Measurement SW: DASY4, V4.7 Build 80; Postprocessing SW: SEMCAD, V1.8 Build 186

SAM Phone Against Flat Section/Tablet Partial Face (front/back) Area Scan - Normal Body

(15mm) (21x6x1): Measurement grid: dx=15mm, dy=15mm

Maximum value of SAR (measured) = 0.509 mW/g

SAM Phone Against Flat Section/5x5x7 Zoom Scan (<=3GHz) (5x5x7)/Cube 0: Measurement grid:

dx=8mm, dy=8mm, dz=5mm

Reference Value = 20.7 V/m; Power Drift = -0.069 dB

Peak SAR (extrapolated) = 1.46 W/kg

SAR(1 g) = 0.669 mW/g; SAR(10 g) = 0.346 mW/g

Maximum value of SAR (measured) = 0.803 mW/g

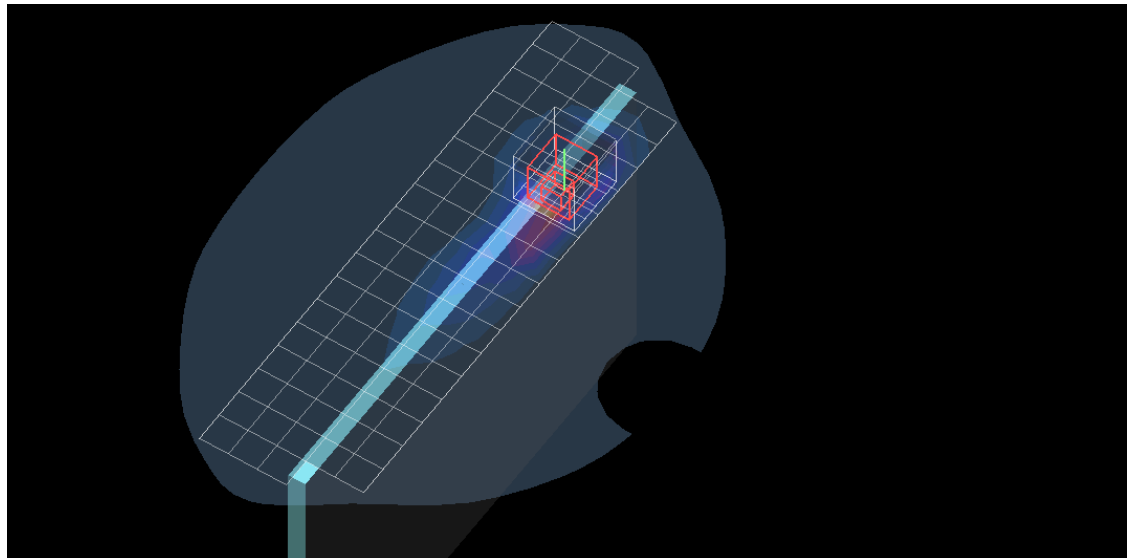
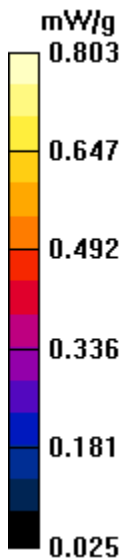

Test Laboratory: Motorola Mobility - GPRS 1900 - Top Edge

DUT: Serial: KPUA020375, FCC ID: IHDP56MF2

Procedure Notes: Pwr Step: 0,0 Battery Model #: INTERNAL Test Configuration = Top Edge 0mm from Phantom
Communication System: GPRS 1900 - Class 10; Frequency: 1909.8 MHz; Duty Cycle: 1:4.15

Medium: Regular Glycol Body 1750/1880; Medium parameters used: $f = 1880$ MHz; $\sigma = 1.59$ mho/m; $\epsilon_r = 50.9$; $\rho = 1000$ kg/m³

DASY4 Configuration:

- Probe: ES3DV3 - SN3115; ConvF(4.61, 4.61, 4.61); Calibrated: 1/12/2011
- Sensor-Surface: 4mm (Mechanical Surface Detection)
- Electronics: DAE3 Sn434; Calibrated: 1/13/2011
- Phantom: R#-6 Glycol SAM (extended range), Rev.1 (25-Mar-05); Type: SAM v4.0; Serial: TP-1131;
- Measurement SW: DASY4, V4.7 Build 80; Postprocessing SW: SEMCAD, V1.8 Build 186

SAM Phone Against Flat Section/Tablet Long Edge Area Scan - Body (15mm) (21x6x1):

Measurement grid: dx=15mm, dy=15mm

Maximum value of SAR (measured) = 0.753 mW/g

SAM Phone Against Flat Section/5x5x7 Zoom Scan (<=3GHz) (5x5x7)/Cube 0: Measurement grid:

dx=8mm, dy=8mm, dz=5mm

Reference Value = 23.4 V/m; Power Drift = -0.146 dB

Peak SAR (extrapolated) = 2.82 W/kg

SAR(1 g) = 1.29 mW/g; SAR(10 g) = 0.534 mW/g

Maximum value of SAR (measured) = 1.58 mW/g

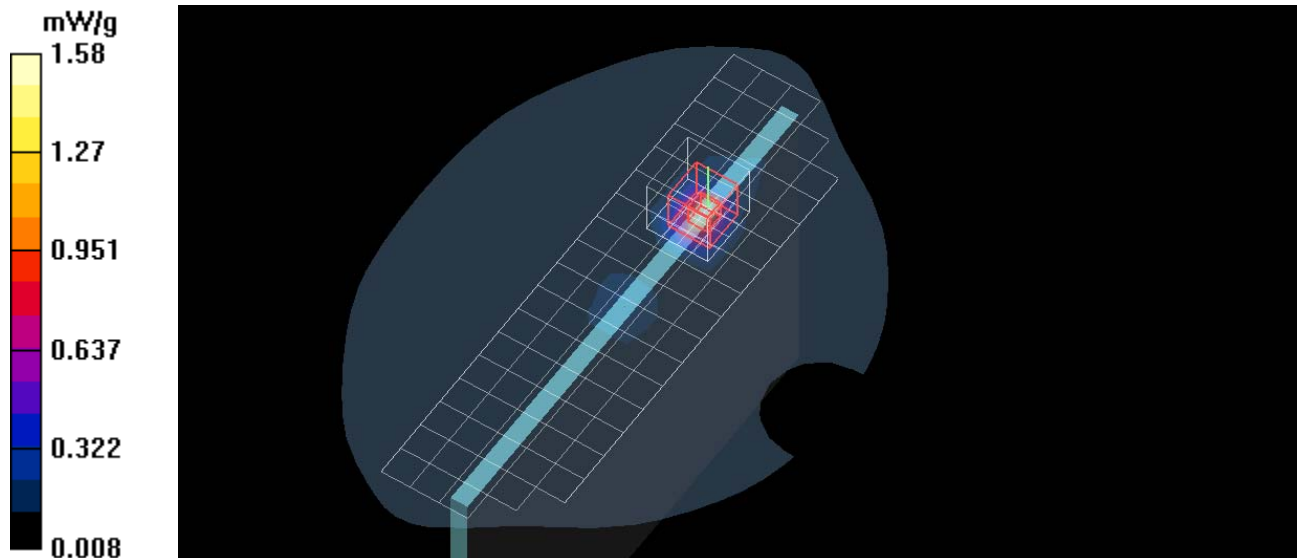

Test Laboratory: Motorola Mobility WCDMA 1900 - Top Edge

DUT: Serial: KPUA020375, FCC ID: IHDP56MF2

Procedure Notes: Pwr Step: ALL UP BITS Battery Model #: INTERNAL Test Configuration = Top Edge 0mm form Phantom

Communication System: 3G/WCDMA 1900; Frequency: 1880 MHz; Duty Cycle: 1:1

Medium: Regular Glycol Body 1750/1880; Medium parameters used: $f = 1880$ MHz; $\sigma = 1.58$ mho/m; $\epsilon_r = 50.8$; $\rho = 1000$ kg/m³

DASY4 Configuration:

- Probe: ES3DV3 - SN3115; ConvF(4.61, 4.61, 4.61); Calibrated: 1/12/2011
- Sensor-Surface: 4mm (Mechanical Surface Detection)
- Electronics: DAE3 Sn434; Calibrated: 1/13/2011
- Phantom: R#-6 Glycol SAM (extended range), Rev.1 (25-Mar-05); Type: SAM v4.0; Serial: TP-1131;
- Measurement SW: DASY4, V4.7 Build 80; Postprocessing SW: SEMCAD, V1.8 Build 186

SAM Phone Against Flat Section/Tablet Long Edge Area Scan - Body (15mm) (21x6x1):

Measurement grid: dx=15mm, dy=15mm

Maximum value of SAR (measured) = 1.03 mW/g

SAM Phone Against Flat Section/5x5x7 Zoom Scan (<=3GHz) (5x5x7)/Cube 0: Measurement grid:

dx=8mm, dy=8mm, dz=5mm

Reference Value = 21.3 V/m; Power Drift = -0.183 dB

Peak SAR (extrapolated) = 2.75 W/kg

SAR(1 g) = 1.31 mW/g; SAR(10 g) = 0.561 mW/g

Maximum value of SAR (measured) = 1.54 mW/g

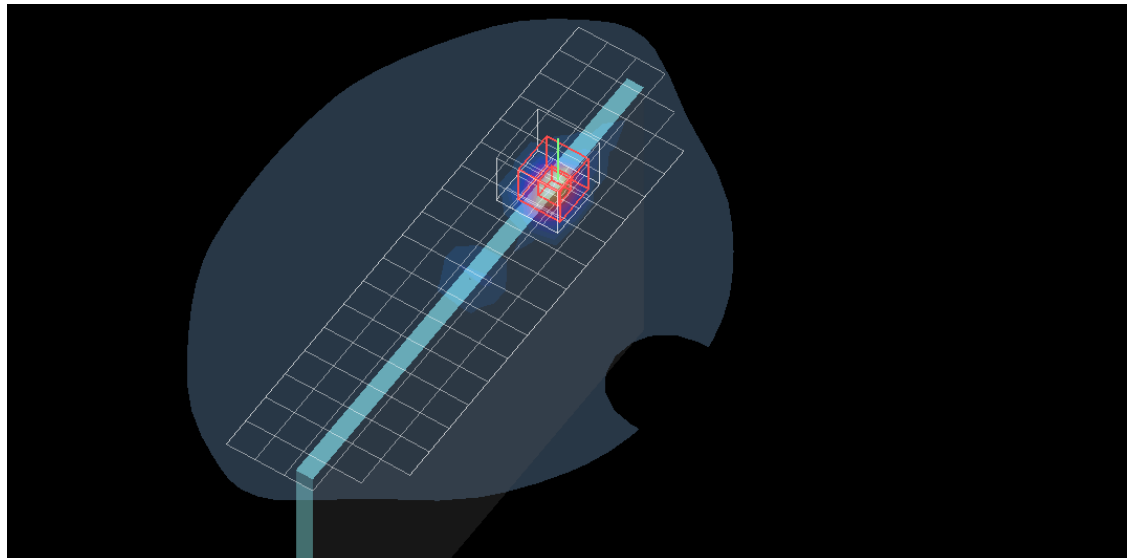
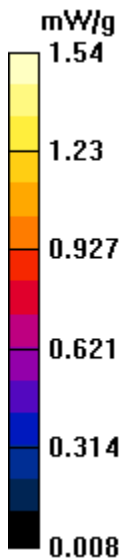

Test Laboratory: Motorola 2450 MHz WiFi - Top Edge

DUT: Serial: KPE00G0052, FCC ID: IHDP56MF1

Procedure Notes: 802.11b 1 Mbps Chn 1 Battery Model #: Internal Tester Test Configuration = Top Edge of DUT 0mm from Flat Phantom

Communication System: Wi-Fi 2450; Frequency: 2412 MHz; Duty Cycle: 1:1

Medium: 2450 Glycol Body; Medium parameters used: $f = 2450$ MHz; $\sigma = 1.92$ mho/m; $\epsilon_r = 51.6$; $\rho = 1000$ kg/m³

DASY4 Configuration:

- Probe: ES3DV3 - SN3184; ConvF(4.33, 4.33, 4.33); Calibrated: 3/11/2011
- Sensor-Surface: 4mm (Mechanical Surface Detection)
- Electronics: DAE4 Sn702; Calibrated: 4/14/2011
- Phantom: R#2 Glycol SAM (extended range), Rev.1 (25-Mar-05); Type: SAM v4.0; Serial: TP-1136;
- Measurement SW: DASY4, V4.7 Build 80; Postprocessing SW: SEMCAD, V1.8 Build 186

SAM Phone Against Flat Section/Tablet Long Edge Area Scan - Body (15mm) (21x6x1):

Measurement grid: dx=15mm, dy=15mm

Maximum value of SAR (measured) = 0.385 mW/g

SAM Phone Against Flat Section/5x5x7 Zoom Scan (<=3GHz) (5x5x7)/Cube 0: Measurement grid:

dx=8mm, dy=8mm, dz=5mm

Reference Value = 13.1 V/m; Power Drift = -0.086 dB

Peak SAR (extrapolated) = 0.758 W/kg

SAR(1 g) = 0.365 mW/g; SAR(10 g) = 0.157 mW/g

Maximum value of SAR (measured) = 0.442 mW/g

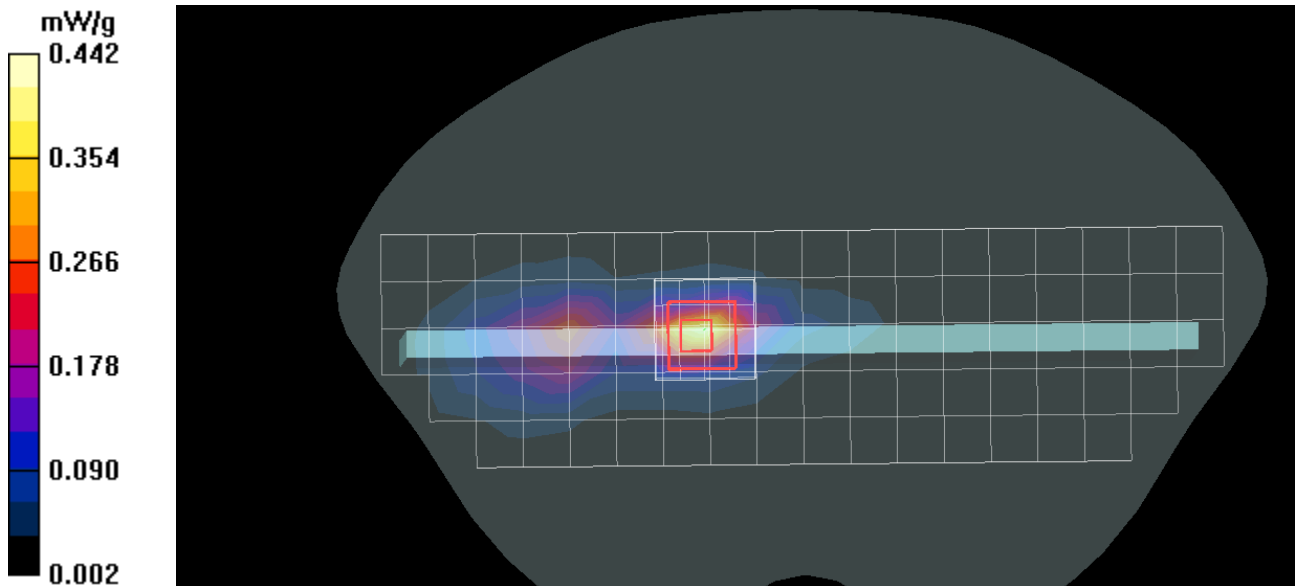

Test Laboratory: Motorola Mobility GPRS 850 - Back Surface

DUT: Serial: KPUA020375, FCC ID: IHDP56MF2

Procedure Notes: Pwr Step: 5 Battery Model #: INTERNAL Test Configuration = Back Surface 0mm from Phantom
Communication System: GPRS 850 - Class 10; Frequency: 848.8 MHz; Duty Cycle: 1:4.15

Medium: big body; Medium parameters used: $f = 835$ MHz; $\sigma = 0.98$ mho/m; $\epsilon_r = 55.6$; $\rho = 1000$ kg/m³

DASY4 Configuration:

- Probe: ES3DV3 - SN3115; ConvF(5.88, 5.88, 5.88); Calibrated: 1/12/2011
- Sensor-Surface: 4mm (Mechanical Surface Detection)
- Electronics: DAE3 Sn434; Calibrated: 1/13/2011
- Phantom: R#-6 Glycol SAM (extended range), Rev.1 (25-Mar-05); Type: SAM v4.0; Serial: TP-1131;
- Measurement SW: DASY4, V4.7 Build 80; Postprocessing SW: SEMCAD, V1.8 Build 186

SAM Phone Against Flat Section/Tablet Partial Face (front/back) Area Scan - Normal Body

(15mm) (21x6x1): Measurement grid: dx=15mm, dy=15mm

Maximum value of SAR (measured) = 0.931 mW/g

SAM Phone Against Flat Section/5x5x7 Zoom Scan (<=3GHz) (5x5x7)/Cube 0: Measurement grid:

dx=8mm, dy=8mm, dz=5mm

Reference Value = 28.1 V/m; Power Drift = 0.095 dB

Peak SAR (extrapolated) = 1.81 W/kg

SAR(1 g) = 0.971 mW/g; SAR(10 g) = 0.533 mW/g

Maximum value of SAR (measured) = 1.08 mW/g

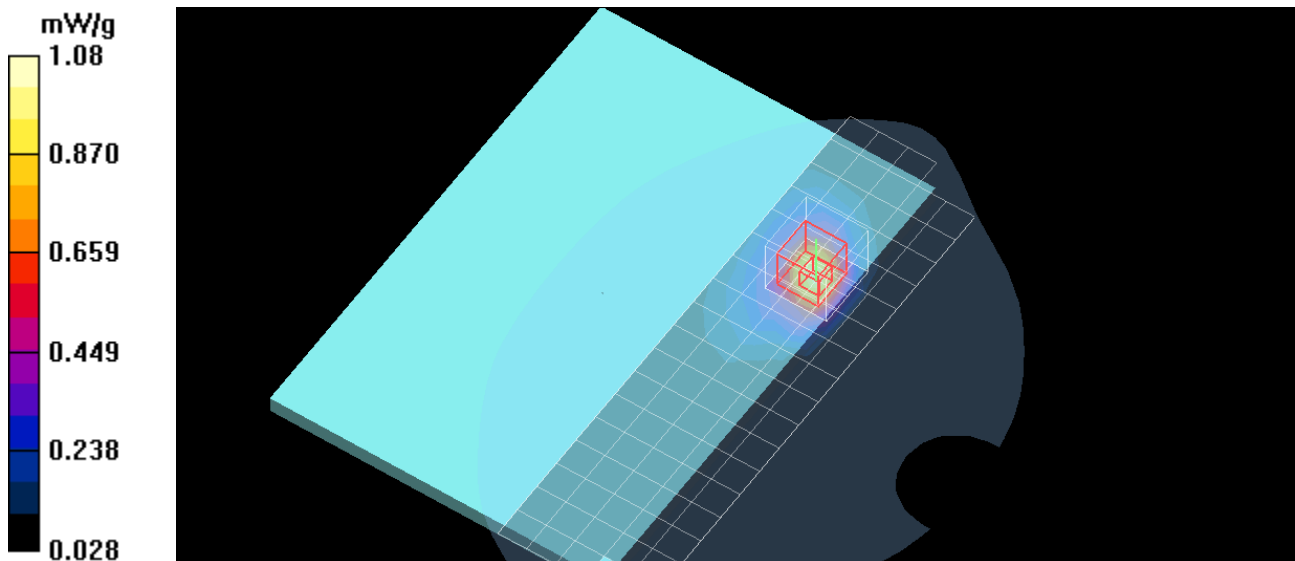

Test Laboratory: Motorola Mobility WCDMA 850 - Back Surface

DUT: Serial: KPUA020375, FCC ID: IHDP56MF2

Procedure Notes: Pwr Step: always up Battery Model #: INTERNAL Test Configuraiton = Back Surface 0mm from Phantom

Communication System: 3G-WCDMA 850; Frequency: 836 MHz;Duty Cycle: 1:1

Medium: big body; Medium parameters used: $f = 835$ MHz; $\sigma = 0.98$ mho/m; $\epsilon_r = 55.6$; $\rho = 1000$ kg/m³

DASY4 Configuration:

- Probe: ES3DV3 - SN3115; ConvF(5.88, 5.88, 5.88); Calibrated: 1/12/2011
- Sensor-Surface: 4mm (Mechanical Surface Detection)
- Electronics: DAE3 Sn434; Calibrated: 1/13/2011
- Phantom: R#-6 Glycol SAM (extended range), Rev.1 (25-Mar-05); Type: SAM v4.0; Serial: TP-1131;
- Measurement SW: DASY4, V4.7 Build 80; Postprocessing SW: SEMCAD, V1.8 Build 186

SAM Phone Against Flat Section/Tablet Partial Face (front/back) Area Scan - Normal Body

(15mm) (21x6x1): Measurement grid: dx=15mm, dy=15mm

Maximum value of SAR (measured) = 0.671 mW/g

SAM Phone Against Flat Section/5x5x7 Zoom Scan (<=3GHz) (5x5x7)/Cube 0: Measurement grid:

dx=8mm, dy=8mm, dz=5mm

Reference Value = 22.2 V/m; Power Drift = 0.100 dB

Peak SAR (extrapolated) = 1.28 W/kg

SAR(1 g) = 0.683 mW/g; SAR(10 g) = 0.378 mW/g

Maximum value of SAR (measured) = 0.733 mW/g

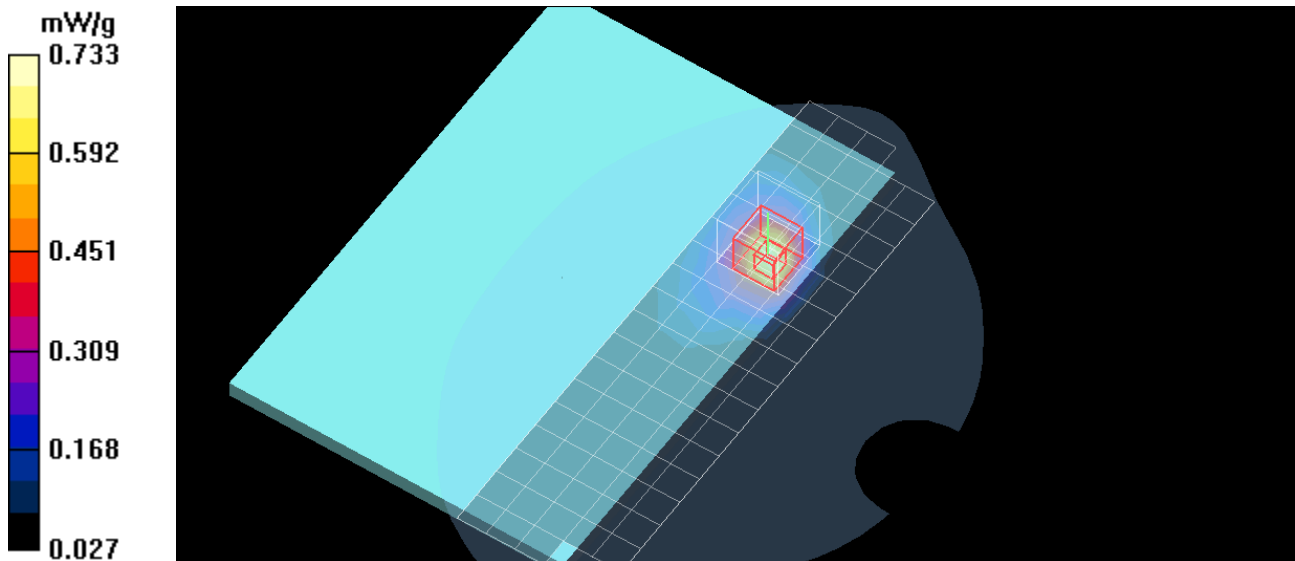

Test Laboratory: Motorola Mobility GPRS 1900 - Back Surface

DUT: Serial: KPUA020375, FCC ID: IHDP56MF2

Procedure Notes: Pwr Step: 0,0 Battery Model #: INTERNAL Test Configuration = Back Surface 0mm from Phantom Communication System: GPRS 1900 - Class 10; Frequency: 1880 MHz; Duty Cycle: 1:4.15

Medium: Regular Glycol Body 1750/1880; Medium parameters used: $f = 1880$ MHz; $\sigma = 1.59$ mho/m; $\epsilon_r = 50.9$; $\rho = 1000$ kg/m³

DASY4 Configuration:

- Probe: ES3DV3 - SN3115; ConvF(4.61, 4.61, 4.61); Calibrated: 1/12/2011
- Sensor-Surface: 4mm (Mechanical Surface Detection)
- Electronics: DAE3 Sn434; Calibrated: 1/13/2011
- Phantom: R#-6 Glycol SAM (extended range), Rev.1 (25-Mar-05); Type: SAM v4.0; Serial: TP-1131;
- Measurement SW: DASY4, V4.7 Build 80; Postprocessing SW: SEMCAD, V1.8 Build 186

SAM Phone Against Flat Section/Tablet Partial Face (front/back) Area Scan - Normal Body

(15mm) (21x6x1): Measurement grid: dx=15mm, dy=15mm

Maximum value of SAR (measured) = 0.826 mW/g

SAM Phone Against Flat Section/5x5x7 Zoom Scan (<=3GHz) (5x5x7)/Cube 0: Measurement grid:

dx=8mm, dy=8mm, dz=5mm

Reference Value = 20.9 V/m; Power Drift = -0.003 dB

Peak SAR (extrapolated) = 1.61 W/kg

SAR(1 g) = 0.794 mW/g; SAR(10 g) = 0.356 mW/g

Maximum value of SAR (measured) = 0.924 mW/g

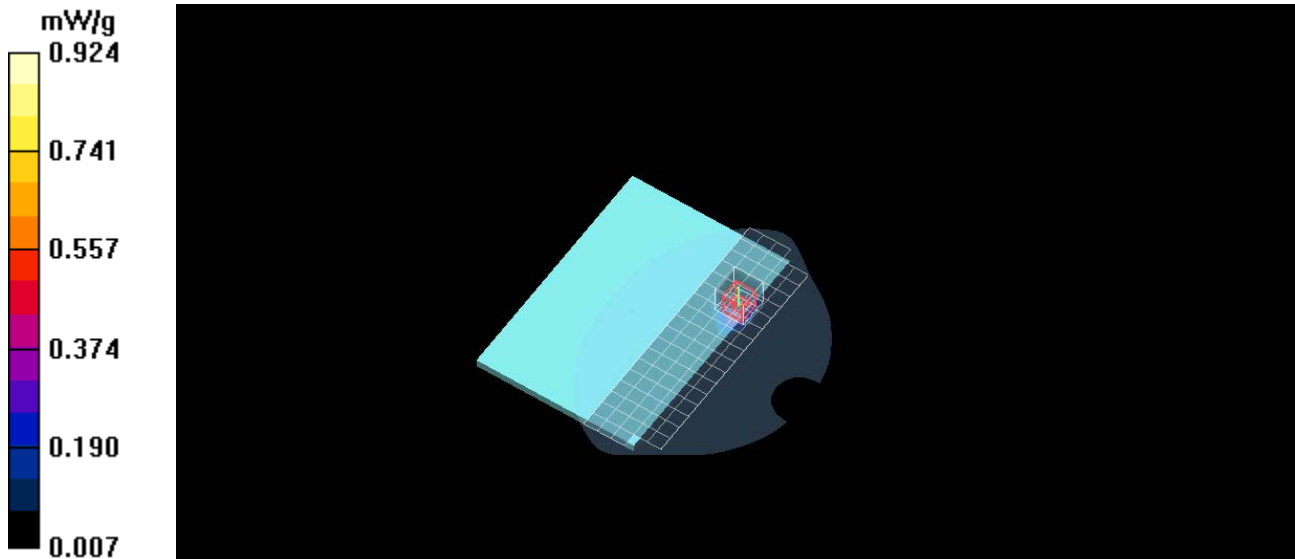

Test Laboratory: Motorola Mobility WCDMA 1900 - Back Surface

DUT: Serial: KPUA020375, FCC ID: IHDP56MF2

Procedure Notes: Pwr Step: ALL UP BITS Battery Model #: INTERNAL Test Configuration = Back Surface 0mm from Phantom

Communication System: 3G/WCDMA 1900; Frequency: 1852.5 MHz; Duty Cycle: 1:1

Medium: Regular Glycol Body 1750/1880; Medium parameters used: $f = 1880$ MHz; $\sigma = 1.58$ mho/m; $\epsilon_r = 50.8$; $\rho = 1000$ kg/m³

DASY4 Configuration:

- Probe: ES3DV3 - SN3115; ConvF(4.61, 4.61, 4.61); Calibrated: 1/12/2011
- Sensor-Surface: 4mm (Mechanical Surface Detection)
- Electronics: DAE3 Sn434; Calibrated: 1/13/2011
- Phantom: R#-6 Glycol SAM (extended range), Rev.1 (25-Mar-05); Type: SAM v4.0; Serial: TP-1131;
- Measurement SW: DASY4, V4.7 Build 80; Postprocessing SW: SEMCAD, V1.8 Build 186

SAM Phone Against Flat Section/Tablet Partial Face (front/back) Area Scan - Normal Body

(15mm) (21x6x1): Measurement grid: dx=15mm, dy=15mm

Maximum value of SAR (measured) = 1.67 mW/g

SAM Phone Against Flat Section/5x5x7 Zoom Scan (<=3GHz) (5x5x7)/Cube 0: Measurement grid:

dx=8mm, dy=8mm, dz=5mm

Reference Value = 28.2 V/m; Power Drift = -0.047 dB

Peak SAR (extrapolated) = 2.97 W/kg

SAR(1 g) = 1.48 mW/g; SAR(10 g) = 0.669 mW/g

Maximum value of SAR (measured) = 1.70 mW/g

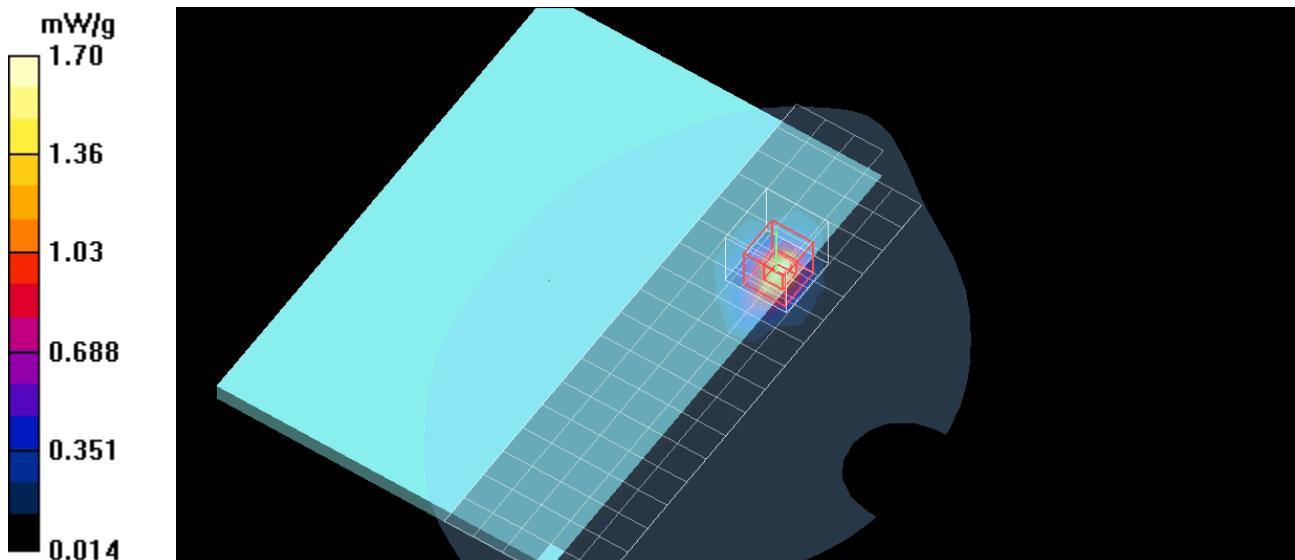

Test Laboratory: Motorola 2450 MHz WiFi - Back Surface

DUT: Serial: KPE00G0052, FCC ID: IHDP56MF1

Procedure Notes: 802.11n 28.9 Mbps Battery Model #: INTERNAL Accessory Model # = Back Surface 0mm from Phantom

Communication System: Wi-Fi 2450; Frequency: 2412 MHz; Duty Cycle: 1:1

Medium: 2450 Glycol Body; Medium parameters used: $f = 2450$ MHz; $\sigma = 1.92$ mho/m; $\epsilon_r = 52$; $\rho = 1000$ kg/m³

DASY4 Configuration:

- Probe: ES3DV3 - SN3184; ConvF(4.33, 4.33, 4.33); Calibrated: 3/11/2011
- Sensor-Surface: 4mm (Mechanical Surface Detection)
- Electronics: DAE4 Sn702; Calibrated: 4/14/2011
- Phantom: R#2 Glycol SAM (extended range), Rev.1 (25-Mar-05); Type: SAM v4.0; Serial: TP-1136;
- Measurement SW: DASY4, V4.7 Build 80; Postprocessing SW: SEMCAD, V1.8 Build 186

SAM Phone Against Flat Section/Tablet Partial Face (front/back) Area Scan - Normal Body

(15mm) (21x6x1): Measurement grid: dx=15mm, dy=15mm

Maximum value of SAR (measured) = 1.32 mW/g

SAM Phone Against Flat Section/5x5x7 Zoom Scan (<=3GHz) (5x5x7)/Cube 0: Measurement grid:

dx=8mm, dy=8mm, dz=5mm

Reference Value = 17.3 V/m; Power Drift = 0.077 dB

Peak SAR (extrapolated) = 3.68 W/kg

SAR(1 g) = 1.42 mW/g; SAR(10 g) = 0.600 mW/g

Maximum value of SAR (measured) = 1.59 mW/g

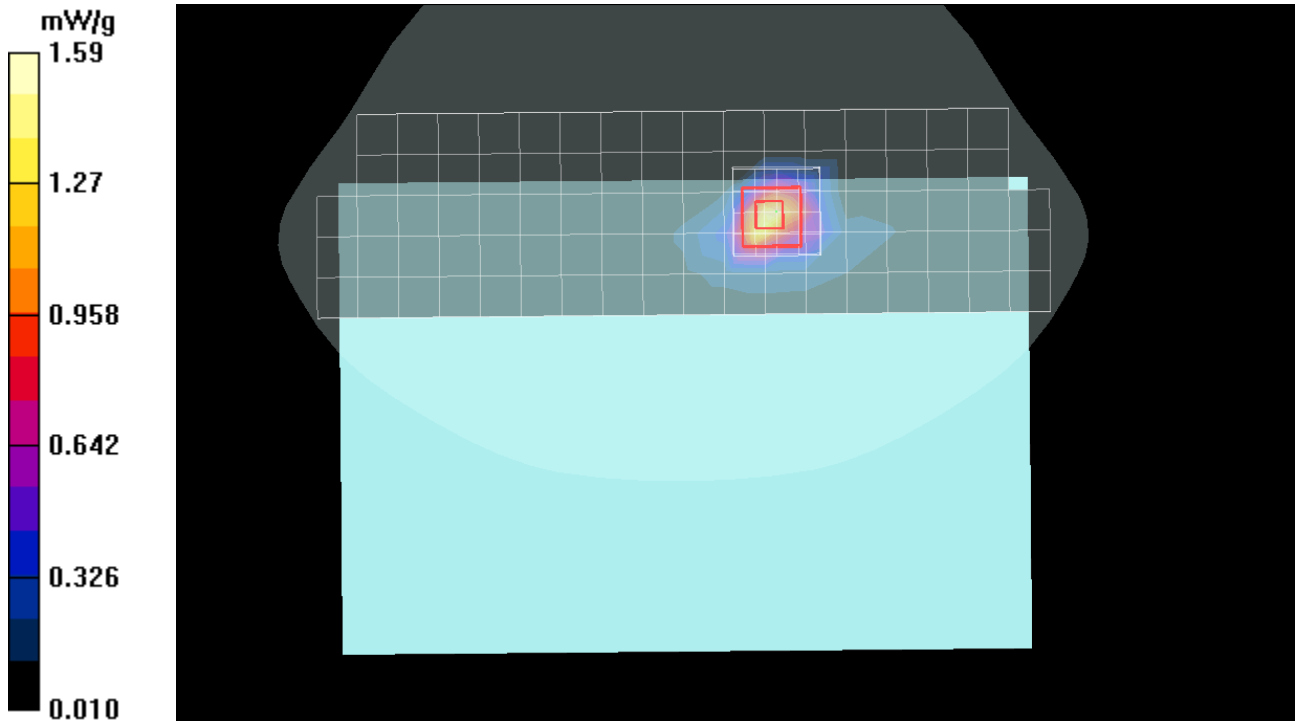

Test Laboratory: Motorola Mobility GPRS 850 - Back Surface w/o Pwr Reduction

DUT: Serial: KPUA020375, FCC ID: IHDP56MF2

Procedure Notes: Pwr Step: 05 Battery Model #: Internal Test Configuration = Back of Tablet 11mm from Phantom
Communication System: GPRS 850 - Class 10; Frequency: 848.8 MHz; Duty Cycle: 1:4.15

Medium: Low Freq Body; Medium parameters used: $f = 835$ MHz; $\sigma = 0.99$ mho/m; $\epsilon_r = 55.3$; $\rho = 1000$ kg/m³

DASY4 Configuration:

- Probe: ES3DV3 - SN3184; ConvF(6.1, 6.1, 6.1); Calibrated: 3/11/2011
- Sensor-Surface: 4mm (Mechanical Surface Detection)
- Electronics: DAE4 Sn702; Calibrated: 4/14/2011
- Phantom: R#2 Glycol SAM (extended range), Rev.1 (25-Mar-05); Type: SAM v4.0; Serial: TP-1136;
- Measurement SW: DASY4, V4.7 Build 80; Postprocessing SW: SEMCAD, V1.8 Build 186

SAM Phone Against Flat Section/Tablet Partial Face (front/back) Area Scan - Normal Body

(10mm) (31x8x1): Measurement grid: dx=10mm, dy=10mm

Maximum value of SAR (measured) = 0.552 mW/g

SAM Phone Against Flat Section/5x5x7 Zoom Scan (<=3GHz) (5x5x7)/Cube 0: Measurement grid:

dx=8mm, dy=8mm, dz=5mm

Reference Value = 22.4 V/m; Power Drift = -0.170 dB

Peak SAR (extrapolated) = 0.798 W/kg

SAR(1 g) = 0.518 mW/g; SAR(10 g) = 0.336 mW/g

Maximum value of SAR (measured) = 0.562 mW/g

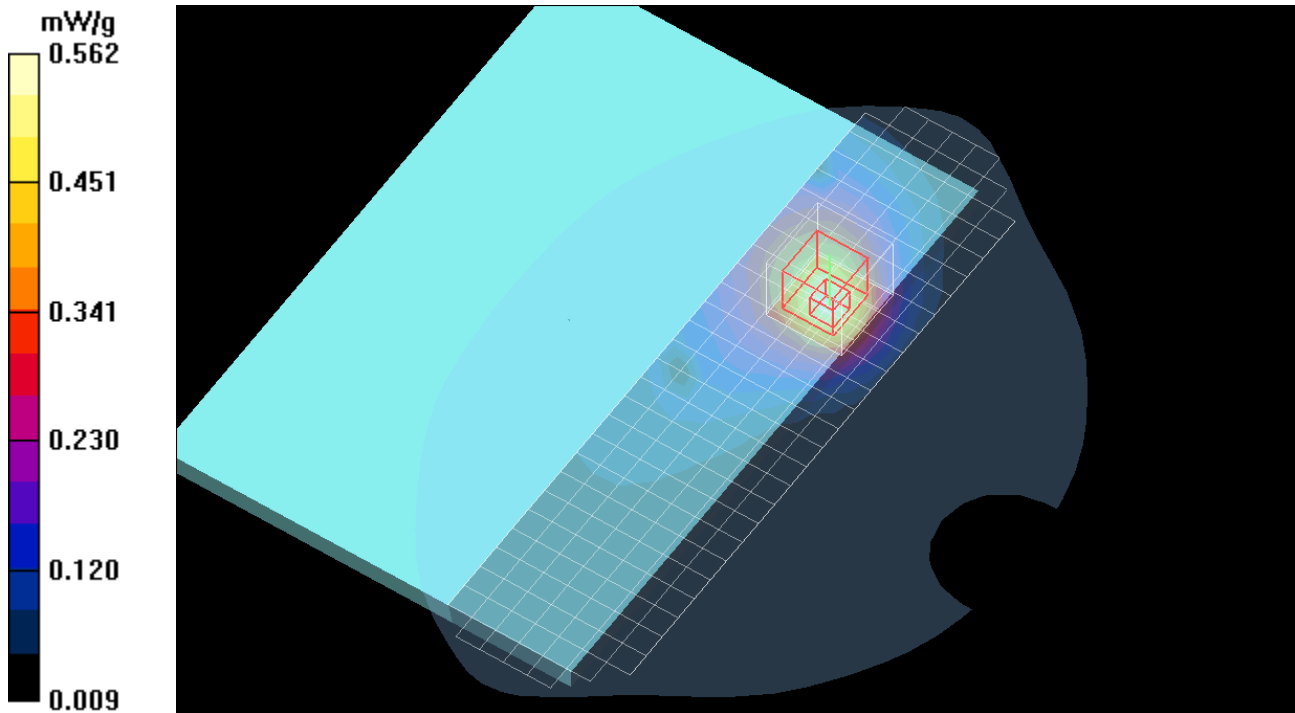

Test Laboratory: Motorola Mobility WCDMA 850 - Back Surface w/o Pwr Reduction

DUT: Serial: KPUA020375, FCC ID: IHDP56MF2

Procedure Notes: Pwr Step: always up Battery Model #: Internal Test Configuration = Back of Tablet 11mm from Phantom

Communication System: 3G-WCDMA 850; Frequency: 836 MHz; Duty Cycle: 1:1

Medium: Low Freq Body; Medium parameters used: $f = 835$ MHz; $\sigma = 0.99$ mho/m; $\epsilon_r = 55.3$; $\rho = 1000$ kg/m³

DASY4 Configuration:

- Probe: ES3DV3 - SN3184; ConvF(6.1, 6.1, 6.1); Calibrated: 3/11/2011
- Sensor-Surface: 4mm (Mechanical Surface Detection)
- Electronics: DAE4 Sn702; Calibrated: 4/14/2011
- Phantom: R#2 Glycol SAM (extended range), Rev.1 (25-Mar-05); Type: SAM v4.0; Serial: TP-1136;
- Measurement SW: DASY4, V4.7 Build 80; Postprocessing SW: SEMCAD, V1.8 Build 186

SAM Phone Against Flat Section/Tablet Partial Face (front/back) Area Scan - Normal Body

(10mm) (31x8x1): Measurement grid: dx=10mm, dy=10mm

Maximum value of SAR (measured) = 0.303 mW/g

SAM Phone Against Flat Section/5x5x7 Zoom Scan (<=3GHz) (5x5x7)/Cube 0: Measurement grid:

dx=8mm, dy=8mm, dz=5mm

Reference Value = 17.2 V/m; Power Drift = -0.044 dB

Peak SAR (extrapolated) = 0.461 W/kg

SAR(1 g) = 0.298 mW/g; SAR(10 g) = 0.191 mW/g

Maximum value of SAR (measured) = 0.323 mW/g

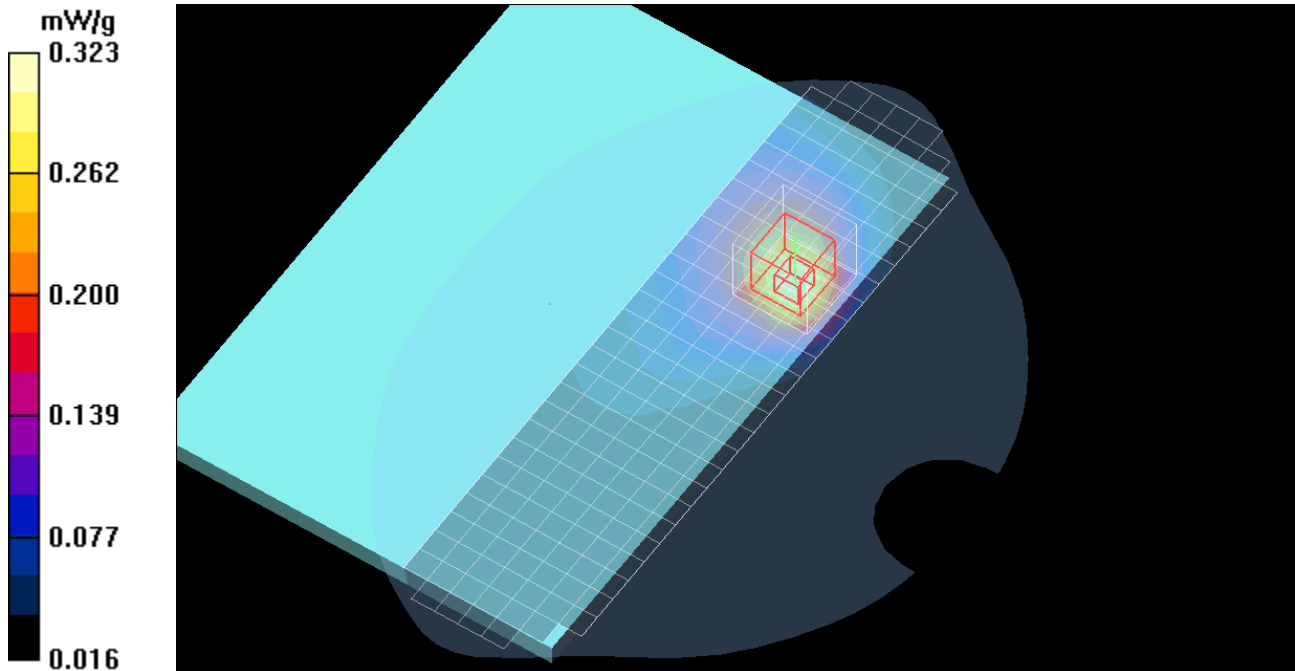

Test Laboratory: Motorola Mobility GPRS 1900 - Back Surface w/o Pwr Reduction

DUT: Serial: KPUA020375, FCC ID: IHDP56MF2

Procedure Notes: Pwr Step: 0 Battery Model #: Internal Test Configuration = Back of Tablet 11mm from Phantom
 Communication System: GPRS 1900 - Class 10; Frequency: 1880 MHz; Duty Cycle: 1:4.15
 Medium: Regular Glycol Body 1750/1880; Medium parameters used: $f = 1880$ MHz; $\sigma = 1.58$ mho/m; $\epsilon_r = 50.7$; $\rho = 1000$ kg/m³

DASY4 Configuration:

- Probe: ES3DV3 - SN3184; ConvF(4.9, 4.9, 4.9); Calibrated: 3/11/2011
- Sensor-Surface: 4mm (Mechanical Surface Detection)
- Electronics: DAE4 Sn702; Calibrated: 4/14/2011
- Phantom: R#2 Glycol SAM (extended range), Rev.1 (25-Mar-05); Type: SAM v4.0; Serial: TP-1136;
- Measurement SW: DASY4, V4.7 Build 80; Postprocessing SW: SEMCAD, V1.8 Build 186

SAM Phone Against Flat Section/Tablet Partial Face (front/back) Area Scan - Normal Body

(15mm) (21x6x1): Measurement grid: dx=15mm, dy=15mm

Maximum value of SAR (measured) = 0.700 mW/g

SAM Phone Against Flat Section/5x5x7 Zoom Scan (<=3GHz) (5x5x7)/Cube 0: Measurement grid:

dx=8mm, dy=8mm, dz=5mm

Reference Value = 18.5 V/m; Power Drift = -0.181 dB

Peak SAR (extrapolated) = 1.25 W/kg

SAR(1 g) = 0.729 mW/g; SAR(10 g) = 0.396 mW/g

Maximum value of SAR (measured) = 0.815 mW/g

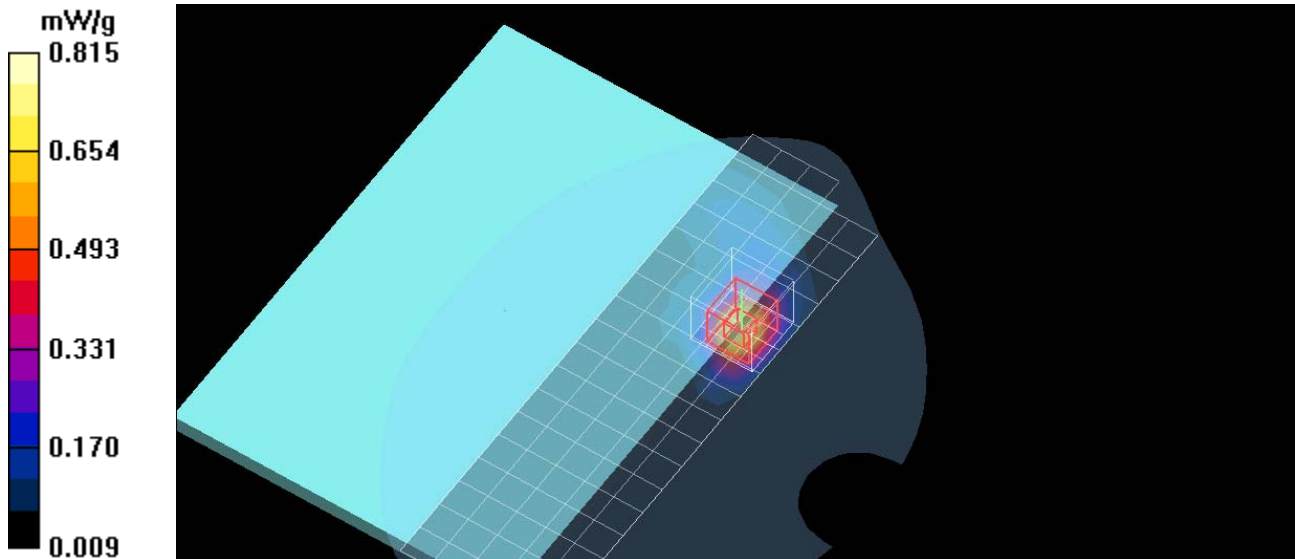

Test Laboratory: Motorola Mobility WCDMA 1900 - Back Surface w/o Pwr Reduction

DUT: Serial: KPUA020375, FCC ID: IHDP56MF2

Procedure Notes: Pwr Step: always up Battery Model #: Internal Test Configuration = Back of Tablet 11mm from Phantom

Communication System: 3G/WCDMA 1900; Frequency: 1852.5 MHz; Duty Cycle: 1:1

Medium: Regular Glycol Body 1750/1880; Medium parameters used: $f = 1880$ MHz; $\sigma = 1.58$ mho/m; $\epsilon_r = 51.1$; $\rho = 1000$ kg/m³

DASY4 Configuration:

- Probe: ES3DV3 - SN3184; ConvF(4.9, 4.9, 4.9); Calibrated: 3/11/2011
- Sensor-Surface: 4mm (Mechanical Surface Detection)
- Electronics: DAE4 Sn702; Calibrated: 4/14/2011
- Phantom: R#2 Glycol SAM (extended range), Rev.1 (25-Mar-05); Type: SAM v4.0; Serial: TP-1136;
- Measurement SW: DASY4, V4.7 Build 80; Postprocessing SW: SEMCAD, V1.8 Build 186

SAM Phone Against Flat Section/Tablet Partial Face (front/back) Area Scan - Normal Body

(10mm) (31x8x1): Measurement grid: dx=10mm, dy=10mm

Maximum value of SAR (measured) = 0.263 mW/g

SAM Phone Against Flat Section/5x5x7 Zoom Scan (<=3GHz) (5x5x7)/Cube 0: Measurement grid:

dx=8mm, dy=8mm, dz=5mm

Reference Value = 11.9 V/m; Power Drift = -0.452 dB

Peak SAR (extrapolated) = 0.351 W/kg

SAR(1 g) = 0.220 mW/g; SAR(10 g) = 0.125 mW/g

Maximum value of SAR (measured) = 0.243 mW/g

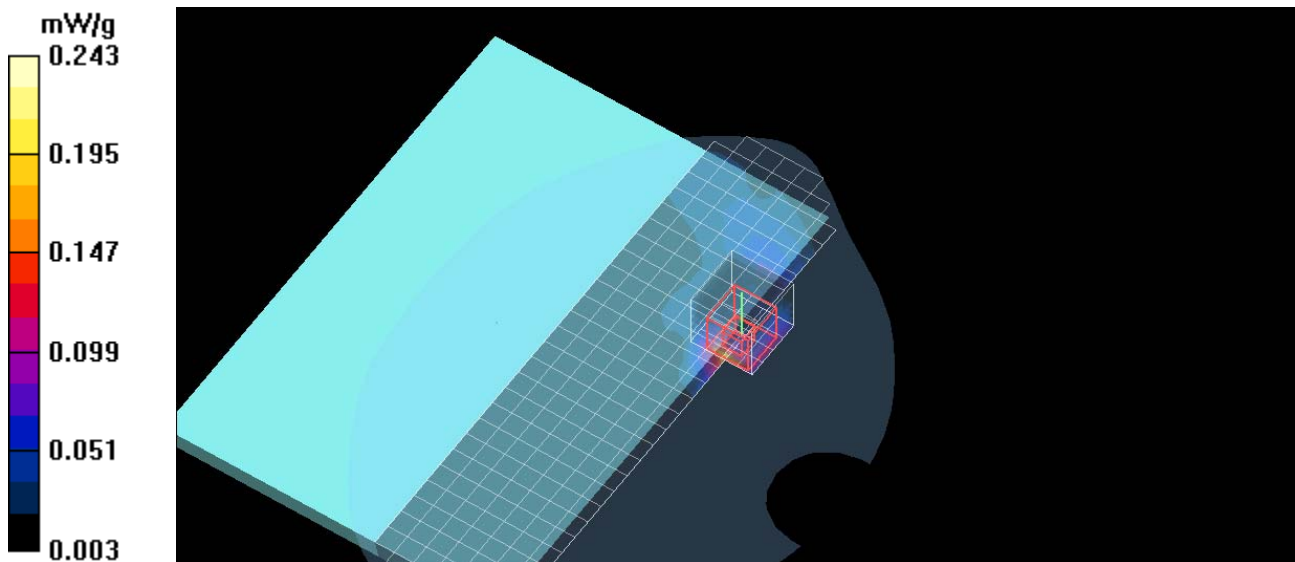

Appendix 3

SAR distribution plots for Simultaneous Transmission

WCDMA 1900 and WiFi 2450 MHz Back Surface Simultaneous Evaluation

DASY4 Configuration for MegaZoom for FCC ID IHDP56MF2/SAM Tablet Against Flat Section/MegaZoom Scan (<=3GHz):

Date/Time: 10/7/2011 3:21:36 PM

Test Laboratory: Motorola Mobility

DUT: Serial: KPE00G0052, FCC ID IHDP56MF2

Communication System: Wi-Fi 2450; Frequency: 2412 MHz; Duty Cycle: 1:1

Medium: 2450 Glycol Body Medium parameters used: $f = 2450$ MHz; $\sigma = 1.92$ mho/m; $\epsilon_r = 51.1$; $\rho = 1000$ kg/m³

Phantom section: Flat Section

Measurement Standard: DASY4 (High Precision Assessment)

- Probe: ES3DV3 - SN3184; ConvF(4.33, 4.33, 4.33); Calibrated: 3/11/2011
- Sensor-Surface: 4mm (Mechanical Surface Detection)
- Electronics: DAE4 Sn702; Calibrated: 4/14/2011
- Phantom: R#2 Glycol SAM (extended range), Rev.1 (25-Mar-05); Type: SAM v4.0; Serial: TP-1136
- Measurement SW: DASY4, V4.7 Build 80

Reference Value = 28.3 V/m; Power Drift = 0.031 dB

Peak SAR (extrapolated) = 2.72 W/kg

SAR(1 g) = 1.38 mW/g; SAR(10 g) = 0.645 mW/g

Maximum value of SAR (measured) = 1.45 mW/g

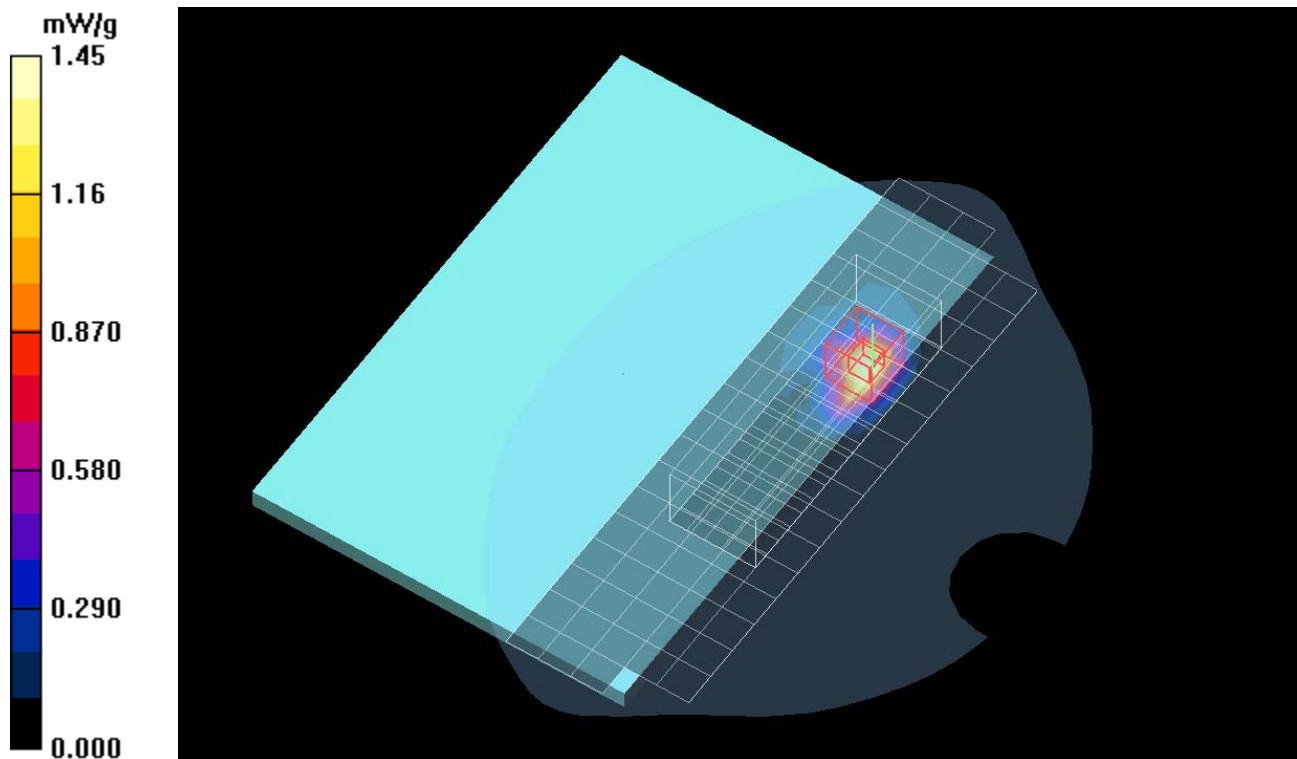

DASY4 Configuration for MegaZoom for FCC ID IHDP56MF2/SAM Tablet Against Flat Section/MegaZoom Scan (<=3GHz):

Date/Time: 10/14/2011 10:04:08 AM

Test Laboratory: Motorola Mobility

DUT: Serial: KPUA020375, FCC ID IHDP56MF2

Communication System: 3G/WCDMA 1900; Frequency: 1852.5 MHz; Duty Cycle: 1:1
Medium: Regular Glycol Body 1750/1880 Medium parameters used: $f = 1880$ MHz; $\sigma = 1.59$ mho/m; $\epsilon_r = 50.8$; $\rho = 1000$ kg/m³
Phantom section: Flat Section
Measurement Standard: DAS4 (High Precision Assessment)

- Probe: ES3DV3 - SN3184; ConvF(4.9, 4.9, 4.9); Calibrated: 3/11/2011
- Sensor-Surface: 4mm (Mechanical Surface Detection)
- Electronics: DAE4 Sn702; Calibrated: 4/14/2011
- Phantom: R#2 Glycol SAM (extended range), Rev.1 (25-Mar-05); Type: SAM v4.0; Serial: TP-1136
- Measurement SW: DAS4, V4.7 Build 80

Reference Value = 19.7 V/m; Power Drift = -0.174 dB
Peak SAR (extrapolated) = 2.94 W/kg
SAR(1 g) = 1.18 mW/g; SAR(10 g) = 0.501 mW/g
Maximum value of SAR (measured) = 1.34 mW/g

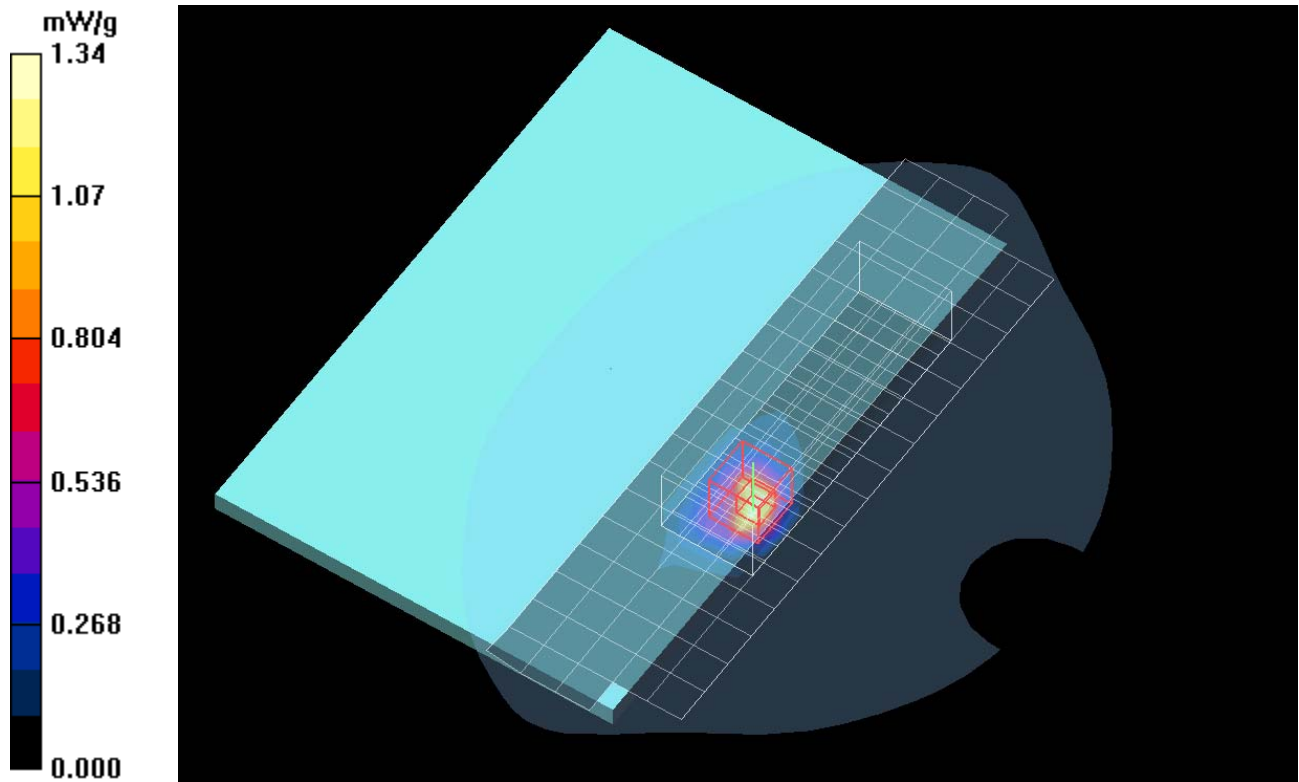

Multi Band Result:

SAR(1 g) = 1.38 mW/g; SAR(10 g) = 0.648 mW/g
Maximum value of SAR (measured) = 1.45 mW/g

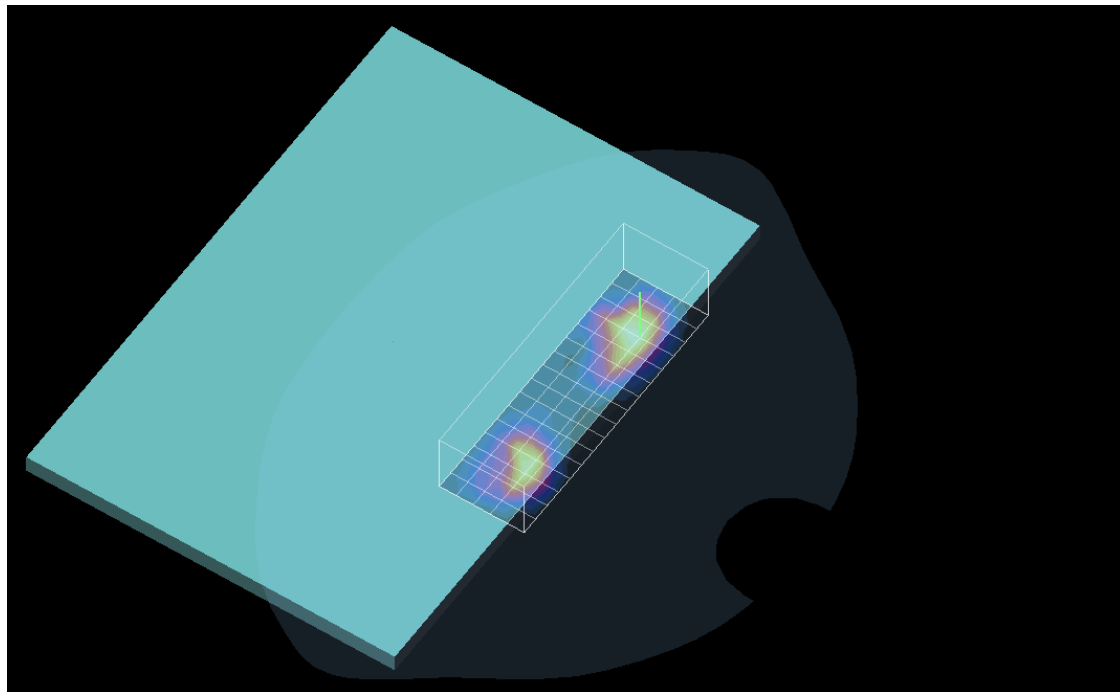
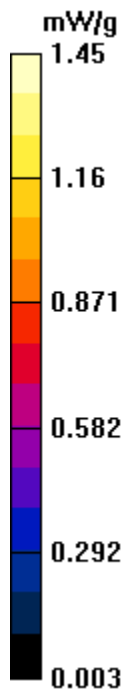

Appendix 4

Measurement Uncertainty Budget

Uncertainty Budget for Device Under Test, for 735 MHz to 2 GHz

<i>a</i>	<i>b</i>	<i>c</i>	<i>d</i>	$e = f(d,k)$	<i>f</i>	<i>g</i>	$h = c \times f / e$	$i = c \times g / e$	<i>k</i>
Uncertainty Component	Description IEEE1528(2003) / IEC62209-1(2005)	Tol. (± %)	Prob Dist	Div.	<i>c_i</i> (1 g)	<i>c_i</i> (10 g)	1 g <i>u_i</i> (±%)	10 g <i>u_i</i> (±%)	<i>v_i</i>
Measurement System									
Probe Calibration [ES3DV3]	E.2.1 / 7.2.1	6.0	N	1.00	1	1	6.0	6.0	∞
Axial Isotropy	E.2.2 / 7.2.1.2	4.7	R	1.73	0.707	0.707	1.9	1.9	∞
Hemispherical Isotropy	E.2.2 / 7.2.1.2	9.6	R	1.73	0.707	0.707	3.9	3.9	∞
Boundary Effect	E.2.3 / 7.2.1.5	1.0	R	1.73	1	1	0.6	0.6	∞
Linearity	E.2.4 / 7.2.1.3	4.7	R	1.73	1	1	2.7	2.7	∞
System Detection Limits	E.2.5 / 7.2.1.4	1.0	R	1.73	1	1	0.6	0.6	∞
Readout Electronics	E.2.6 / 7.2.1.6	0.3	N	1.00	1	1	0.3	0.3	∞
Response Time	E.2.7 / 7.2.1.7	1.1	R	1.73	1	1	0.6	0.6	∞
Integration Time	E.2.8 / 7.2.1.8	1.1	R	1.73	1	1	0.6	0.6	∞
RF Ambient Conditions - Noise	E.6.1 / 7.2.3.6	3.0	R	1.73	1	1	1.7	1.7	∞
RF Ambient Conditions - Reflections	E.6.1 / 7.2.3.6	3.0	R	1.73	1	1	1.7	1.7	∞
Probe Positioner Mech. Tolerance	E.6.2 / 7.2.2.1	0.4	R	1.73	1	1	0.2	0.2	∞
Probe Positioning w.r.t Phantom	E.6.3 / 7.2.2.3	1.4	R	1.73	1	1	0.8	0.8	∞
Max. SAR Evaluation (ext., int., avg.)	E.5 / 7.2.4	3.4	R	1.73	1	1	2.0	2.0	∞
Test sample Related									
Test Sample Positioning	E.4.2 / 7.2.2.4	3.4	N	1.00	1	1	3.4	3.4	79
Device Holder Uncertainty	E.4.1 / 7.2.2.4.2	4.5	N	1.00	1	1	4.5	4.5	11
SAR drift	6.6.2 / 7.2.3.5	0.0	R	1.73	1	1	0.0	0.0	∞
Phantom and Tissue Parameters									
Phantom Uncertainty	E.3.1 / 7.2.2.2	4.0	R	1.73	1	1	2.3	2.3	∞
Liquid Conductivity (target)	E.3.2 / 7.2.3.3	5.0	R	1.73	0.64	0.43	1.8	1.2	∞
Liquid Conductivity (measurement)	E.3.3 / 7.2.3.3	2.5	N	1.00	0.64	0.43	1.6	1.1	6
Liquid Permittivity (target)	E.3.2 / 7.2.3.4	5.0	R	1.73	0.6	0.49	1.7	1.4	∞
Liquid Permittivity (measurement)	E.3.2 / 7.2.3.4	2.3	N	1.00	0.6	0.49	1.4	1.1	6
Combined Standard Uncertainty			RSS				11	11	424
Expanded Uncertainty (95% CONFIDENCE LEVEL)			<i>k</i> =2				22	21	

Uncertainty Budget for Device Under Test, for 2 GHz to 3 GHz

<i>a</i>	<i>b</i>	<i>c</i>	<i>d</i>	$e = f(d,k)$	<i>f</i>	<i>g</i>	$h = c \times f / e$	$i = c \times g / e$	<i>k</i>
Uncertainty Component	Description IEEE1528(2003) / IEC62209-1(2005)	Tol. (± %)	Prob Dist	Div.	<i>c_i</i> (1 g)	<i>c_i</i> (10 g)	1 g <i>u_i</i> (±%)	10 g <i>u_i</i> (±%)	<i>v_i</i>
Measurement System									
Probe Calibration [ES3DV3]	E.2.1 / 7.2.1	5.5	N	1.00	1	1	5.5	5.5	∞
Axial Isotropy	E.2.2 / 7.2.1.2	4.7	R	1.73	0.707	0.707	1.9	1.9	∞
Hemispherical Isotropy	E.2.2 / 7.2.1.2	9.6	R	1.73	0.707	0.707	3.9	3.9	∞
Boundary Effect	E.2.3 / 7.2.1.5	1.0	R	1.73	1	1	0.6	0.6	∞
Linearity	E.2.4 / 7.2.1.3	4.7	R	1.73	1	1	2.7	2.7	∞
System Detection Limits	E.2.5 / 7.2.1.4	1.0	R	1.73	1	1	0.6	0.6	∞
Readout Electronics	E.2.6 / 7.2.1.6	0.3	N	1.00	1	1	0.3	0.3	∞
Response Time	E.2.7 / 7.2.1.7	1.1	R	1.73	1	1	0.6	0.6	∞
Integration Time	E.2.8 / 7.2.1.8	1.1	R	1.73	1	1	0.6	0.6	∞
RF Ambient Conditions - Noise	E.6.1 / 7.2.3.6	3.0	R	1.73	1	1	1.7	1.7	∞
RF Ambient Conditions - Reflections	E.6.1 / 7.2.3.6	3.0	R	1.73	1	1	1.7	1.7	∞
Probe Positioner Mech. Tolerance	E.6.2 / 7.2.2.1	0.4	R	1.73	1	1	0.2	0.2	∞
Probe Positioning w.r.t Phantom	E.6.3 / 7.2.2.3	1.4	R	1.73	1	1	0.8	0.8	∞
Max. SAR Evaluation (ext., int., avg.)	E.5 / 7.2.4	3.4	R	1.73	1	1	2.0	2.0	∞
Test sample Related									
Test Sample Positioning	E.4.2 / 7.2.2.4	3.4	N	1.00	1	1	3.4	3.4	79
Device Holder Uncertainty	E.4.1 / 7.2.2.4.2	4.5	N	1.00	1	1	4.5	4.5	11
SAR drift	6.6.2 / 7.2.3.5	0.0	R	1.73	1	1	0.0	0.0	∞
Phantom and Tissue Parameters									
Phantom Uncertainty	E.3.1 / 7.2.2.2	4.0	R	1.73	1	1	2.3	2.3	∞
Liquid Conductivity (target)	E.3.2 / 7.2.3.3	5.0	R	1.73	0.64	0.43	1.8	1.2	∞
Liquid Conductivity (measurement)	E.3.3 / 7.2.3.3	2.5	N	1.00	0.64	0.43	1.6	1.1	6
Liquid Permittivity (target)	E.3.2 / 7.2.3.4	10.0	R	1.73	0.6	0.49	3.5	2.8	∞
Liquid Permittivity (measurement)	E.3.2 / 7.2.3.4	2.3	N	1.00	0.6	0.49	1.4	1.1	6
Combined Standard Uncertainty			RSS				11	11	392
Expanded Uncertainty (95% CONFIDENCE LEVEL)			<i>k</i> =2				22	22	

Uncertainty Budget for Device Under Test for 3 to 6 GHz

<i>a</i>	<i>b</i>	<i>c</i>	<i>d</i>	<i>e = f(d,k)</i>	<i>f</i>	<i>g</i>	<i>h = c x f / e</i>	<i>i = c x g / e</i>	<i>k</i>
Uncertainty Component	Description IEC62209- 2(2010)	Tol. (± %)	Prob Dist	Div.	<i>c_i</i> (1 g)	<i>c_i</i> (10 g)	1 g <i>u_i</i> (±%)	10 g <i>u_i</i> (±%)	<i>v_i</i>
Measurement System									
Probe Calibration [EX3DV4]	7.2.2.1	6.6	N	1.00	1	1	6.6	6.6	∞
Axial Isotropy	7.2.2.2	4.7	R	1.73	0.707	0.707	1.9	1.9	∞
Hemispherical Isotropy	7.2.2.2	9.6	R	1.73	0.707	0.707	3.9	3.9	∞
Boundary Effect	7.2.2.6	2.0	R	1.73	1	1	1.2	1.2	∞
Linearity	7.2.2.5	4.7	R	1.73	1	1	2.7	2.7	∞
System Detection Limits	7.2.2	1.0	R	1.73	1	1	0.6	0.6	∞
Readout Electronics	7.2.2.7	0.3	N	1.00	1	1	0.3	0.3	∞
Response Time	7.2.2.8	1.1	R	1.73	1	1	0.6	0.6	∞
Integration Time	7.2.2.9	1.1	R	1.73	1	1	0.6	0.6	∞
RF Ambient Conditions - Noise	7.2.4.5	3.0	R	1.73	1	1	1.7	1.7	∞
RF Ambient Conditions - Reflections	7.2.4.5	3.0	R	1.73	1	1	1.7	1.7	∞
Probe Positioner Mech. Tolerance	7.2.3.1	1.0	R	1.73	1	1	0.6	0.6	∞
Probe Positioning w.r.t Phantom	7.2.3.3	4.0	R	1.73	1	1	2.3	2.3	∞
Max. SAR Evaluation (ext., int., avg.)	7.2.5.3	4.0	R	1.73	1	1	2.3	2.3	∞
Test sample Related									
Test Sample Positioning	7.2.3.4	3.4	N	1.00	1	1	3.4	3.4	79
Device Holder Uncertainty	7.2.3.4	4.5	N	1.00	1	1	4.5	4.5	11
SAR drift	7.2.2.10	5.0	R	1.73	1	1	2.9	2.9	∞
Phantom and Tissue Parameters									
Phantom Uncertainty	7.2.3.2	4.0	R	1.73	1	1	2.3	2.3	∞
Liquid Conductivity (target)		5.0	R	1.73	0.64	0.43	1.8	1.2	∞
Liquid Conductivity (measurement)	7.2.4.3	3.4	N	1.00	0.64	0.43	2.2	1.5	6
Liquid Permittivity (target)		10.0	R	1.73	0.6	0.49	3.5	2.8	∞
Liquid Permittivity (measurement)	7.2.4.3	2.6	N	1.00	0.6	0.49	1.6	1.3	6
Combined Standard Uncertainty									
			RSS				13	12	566
Expanded Uncertainty (95% CONFIDENCE LEVEL)									
			<i>k</i> =2				25	24	

Appendix 4

Probe Calibration Certificate



Accredited by the Swiss Accreditation Service (SAS)
The Swiss Accreditation Service is one of the signatories to the EA
Multilateral Agreement for the recognition of calibration certificates

Accreditation No.: **SCS 108**

Client **Motorola MDB**

Certificate No: **EX3-3728_May11**

CALIBRATION CERTIFICATE

Object **EX3DV4 - SN:3728**

Calibration procedure(s) **QA CAL-01.v7, QA CAL-14.v3, QA CAL-23.v4, QA CAL-25.v3
Calibration procedure for dosimetric E-field probes**

Calibration date: **May 20, 2011**

This calibration certificate documents the traceability to national standards, which realize the physical units of measurements (SI).
The measurements and the uncertainties with confidence probability are given on the following pages and are part of the certificate.

All calibrations have been conducted in the closed laboratory facility: environment temperature (22 ± 3)°C and humidity < 70%.

Calibration Equipment used (M&TE critical for calibration)

Primary Standards	ID	Cal Date (Certificate No.)	Scheduled Calibration
Power meter E4419B	GB41293874	31-Mar-11 (No. 217-01372)	Apr-12
Power sensor E4412A	MY41498087	31-Mar-11 (No. 217-01372)	Apr-12
Reference 3 dB Attenuator	SN: S5054 (3c)	29-Mar-11 (No. 217-01369)	Apr-12
Reference 20 dB Attenuator	SN: S5086 (20b)	29-Mar-11 (No. 217-01367)	Apr-12
Reference 30 dB Attenuator	SN: S5129 (30b)	29-Mar-11 (No. 217-01370)	Apr-12
Reference Probe ES3DV2	SN: 3013	29-Dec-10 (No. ES3-3013_Dec10)	Dec-11
DAE4	SN: 654	3-May-11 (No. DAE4-654_May11)	May-12
Secondary Standards	ID	Check Date (in house)	Scheduled Check
RF generator HP 8648C	US3642U01700	4-Aug-99 (in house check Oct-09)	In house check: Oct-11
Network Analyzer HP 8753E	US37390585	18-Oct-01 (in house check Oct-10)	In house check: Oct-11

	Name	Function	Signature
Calibrated by:	Katja Pokovic	Technical Manager	
Approved by:	Niels Kuster	Quality Manager	

Issued: May 20, 2011

This calibration certificate shall not be reproduced except in full without written approval of the laboratory.



Accredited by the Swiss Accreditation Service (SAS)

Accreditation No.: SCS 108

The Swiss Accreditation Service is one of the signatories to the EA
Multilateral Agreement for the recognition of calibration certificates

Glossary:

TSL	tissue simulating liquid
NORM _{x,y,z}	sensitivity in free space
ConvF	sensitivity in TSL / NORM _{x,y,z}
DCP	diode compression point
CF	crest factor (1/duty_cycle) of the RF signal
A, B, C	modulation dependent linearization parameters
Polarization φ	φ rotation around probe axis
Polarization ϑ	ϑ rotation around an axis that is in the plane normal to probe axis (at measurement center), i.e., $\vartheta = 0$ is normal to probe axis

Calibration is Performed According to the Following Standards:

- IEEE Std 1528-2003, "IEEE Recommended Practice for Determining the Peak Spatial-Averaged Specific Absorption Rate (SAR) in the Human Head from Wireless Communications Devices: Measurement Techniques", December 2003
- IEC 62209-1, "Procedure to measure the Specific Absorption Rate (SAR) for hand-held devices used in close proximity to the ear (frequency range of 300 MHz to 3 GHz)", February 2005

Methods Applied and Interpretation of Parameters:

- NORM_{x,y,z}**: Assessed for E-field polarization $\vartheta = 0$ ($f \leq 900$ MHz in TEM-cell; $f > 1800$ MHz: R22 waveguide). NORM_{x,y,z} are only intermediate values, i.e., the uncertainties of NORM_{x,y,z} does not affect the E²-field uncertainty inside TSL (see below ConvF).
- NORM(f)_{x,y,z} = NORM_{x,y,z} * frequency_response** (see Frequency Response Chart). This linearization is implemented in DASY4 software versions later than 4.2. The uncertainty of the frequency response is included in the stated uncertainty of ConvF.
- DCP_{x,y,z}**: DCP are numerical linearization parameters assessed based on the data of power sweep with CW signal (no uncertainty required). DCP does not depend on frequency nor media.
- PAR**: PAR is the Peak to Average Ratio that is not calibrated but determined based on the signal characteristics
- A_{x,y,z}; B_{x,y,z}; C_{x,y,z}** are numerical linearization parameters in dB assessed based on the data of power sweep for specific modulation signal. The parameters do not depend on frequency nor media.
- VR**: VR is the validity range of the calibration related to the average diode voltage or DAE voltage in mV.
- ConvF and Boundary Effect Parameters**: Assessed in flat phantom using E-field (or Temperature Transfer Standard for $f \leq 800$ MHz) and inside waveguide using analytical field distributions based on power measurements for $f > 800$ MHz. The same setups are used for assessment of the parameters applied for boundary compensation (alpha, depth) of which typical uncertainty values are given. These parameters are used in DASY4 software to improve probe accuracy close to the boundary. The sensitivity in TSL corresponds to NORM_{x,y,z} * ConvF whereby the uncertainty corresponds to that given for ConvF. A frequency dependent ConvF is used in DASY version 4.4 and higher which allows extending the validity from ± 50 MHz to ± 100 MHz.
- Spherical isotropy (3D deviation from isotropy)**: in a field of low gradients realized using a flat phantom exposed by a patch antenna.
- Sensor Offset**: The sensor offset corresponds to the offset of virtual measurement center from the probe tip (on probe axis). No tolerance required.

Probe EX3DV4

SN:3728

Manufactured: October 19, 2009
Calibrated: May 20, 2011

Calibrated for DASY/EASY Systems
(Note: non-compatible with DASY2 system!)

DASY/EASY - Parameters of Probe: EX3DV4 - SN:3728

Basic Calibration Parameters

	Sensor X	Sensor Y	Sensor Z	Unc (k=2)
Norm ($\mu\text{V}/(\text{V/m})^2$) ^A	0.48	0.45	0.51	$\pm 10.1 \%$
DCP (mV) ^B	99.5	100.3	100.3	

Modulation Calibration Parameters

UID	Communication System Name	PAR		A dB	B dB	C dB	VR mV	Unc ^E (k=2)
10000	CW	0.00	X	0.00	0.00	1.00	110.9	$\pm 1.9 \%$
			Y	0.00	0.00	1.00	113.4	
			Z	0.00	0.00	1.00	115.0	

The reported uncertainty of measurement is stated as the standard uncertainty of measurement multiplied by the coverage factor $k=2$, which for a normal distribution corresponds to a coverage probability of approximately 95%.

^A The uncertainties of NormX,Y,Z do not affect the E^2 -field uncertainty inside TSL (see Pages 5 and 6).

^B Numerical linearization parameter: uncertainty not required.

^E Uncertainty is determined using the max. deviation from linear response applying rectangular distribution and is expressed for the square of the field value.

DASY/EASY - Parameters of Probe: EX3DV4 - SN:3728

Calibration Parameter Determined in Head Tissue Simulating Media

f (MHz) ^c	Relative Permittivity ^f	Conductivity (S/m) ^f	ConvF X	ConvF Y	ConvF Z	Alpha	Depth (mm)	Unct. (k=2)
5200	36.0	4.66	4.64	4.64	4.64	0.42	1.80	± 13.1 %
5300	35.9	4.76	4.34	4.34	4.34	0.42	1.80	± 13.1 %
5600	35.5	5.07	4.01	4.01	4.01	0.50	1.80	± 13.1 %
5800	35.3	5.27	4.13	4.13	4.13	0.45	1.80	± 13.1 %

^c Frequency validity of ± 100 MHz only applies for DASY v4.4 and higher (see Page 2), else it is restricted to ± 50 MHz. The uncertainty is the RSS of the ConvF uncertainty at calibration frequency and the uncertainty for the indicated frequency band.

^f At frequencies below 3 GHz, the validity of tissue parameters (ϵ and σ) can be relaxed to ± 10% if liquid compensation formula is applied to measured SAR values. At frequencies above 3 GHz, the validity of tissue parameters (ϵ and σ) is restricted to ± 5%. The uncertainty is the RSS of the ConvF uncertainty for indicated target tissue parameters.

DASY/EASY - Parameters of Probe: EX3DV4- SN:3728

Calibration Parameter Determined in Body Tissue Simulating Media

f (MHz) ^C	Relative Permittivity ^F	Conductivity (S/m) ^F	ConvF X	ConvF Y	ConvF Z	Alpha	Depth (mm)	Unct. (k=2)
5200	49.0	5.30	4.16	4.16	4.16	0.50	1.90	± 13.1 %
5300	48.9	5.42	3.91	3.91	3.91	0.52	1.90	± 13.1 %
5600	48.5	5.77	3.41	3.41	3.41	0.55	1.90	± 13.1 %
5800	48.2	6.00	3.76	3.76	3.76	0.55	1.90	± 13.1 %

^C Frequency validity of ± 100 MHz only applies for DASY v4.4 and higher (see Page 2), else it is restricted to ± 50 MHz. The uncertainty is the RSS of the ConvF uncertainty at calibration frequency and the uncertainty for the indicated frequency band.

^F At frequencies below 3 GHz, the validity of tissue parameters (ϵ and σ) can be relaxed to ± 10% if liquid compensation formula is applied to measured SAR values. At frequencies above 3 GHz, the validity of tissue parameters (ϵ and σ) is restricted to ± 5%. The uncertainty is the RSS of the ConvF uncertainty for indicated target tissue parameters.

Frequency Response of E-Field (TEM-Cell:ifi110 EXX, Waveguide: R22)

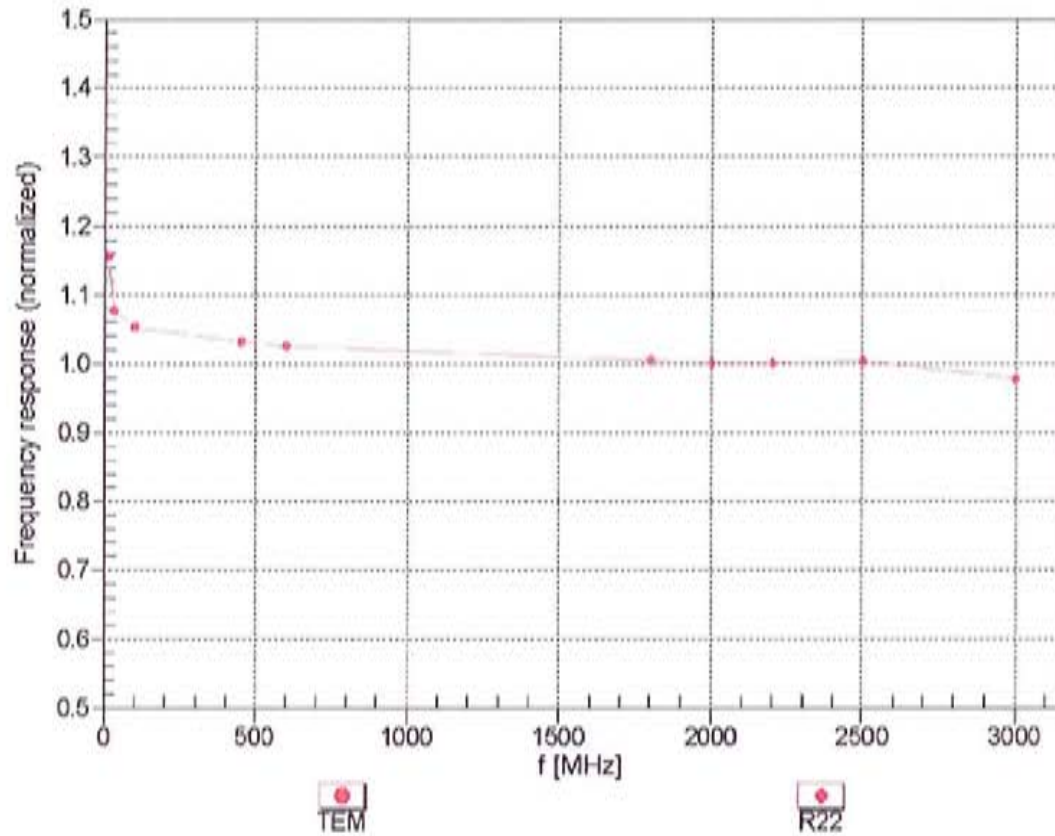

Uncertainty of Frequency Response of E-field: $\pm 6.3\%$ ($k=2$)

Receiving Pattern (ϕ), $\vartheta = 0^\circ$

f=600 MHz, TEM

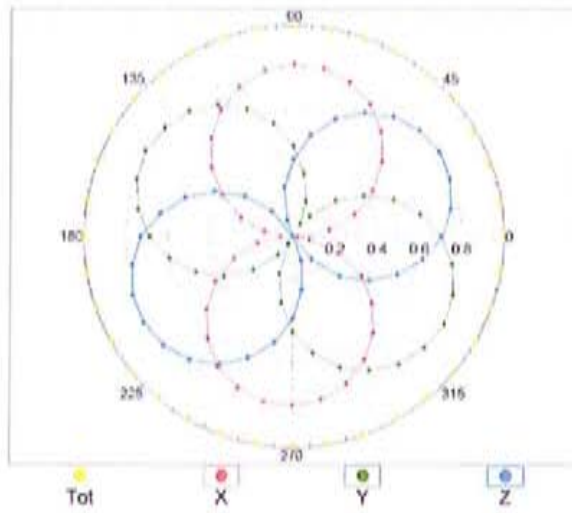

f=1800 MHz, R22

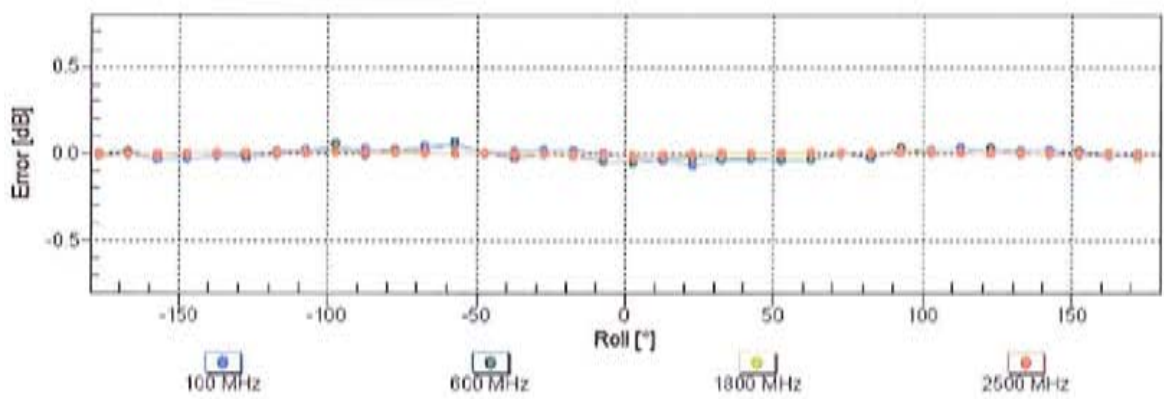
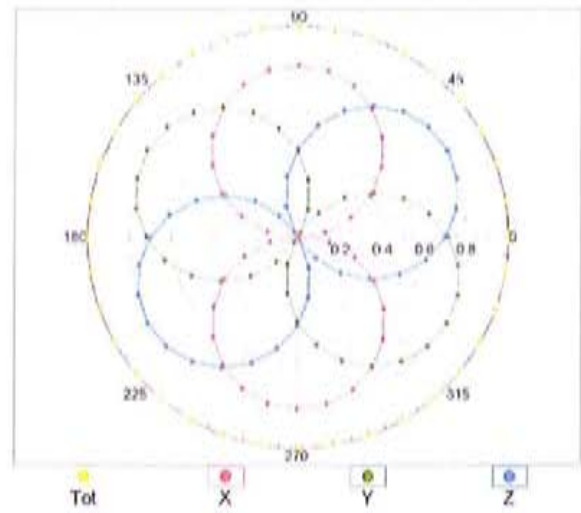

Uncertainty of Axial Isotropy Assessment: $\pm 0.5\%$ ($k=2$)

Dynamic Range f(SAR_{head}) (TEM cell , f = 900 MHz)

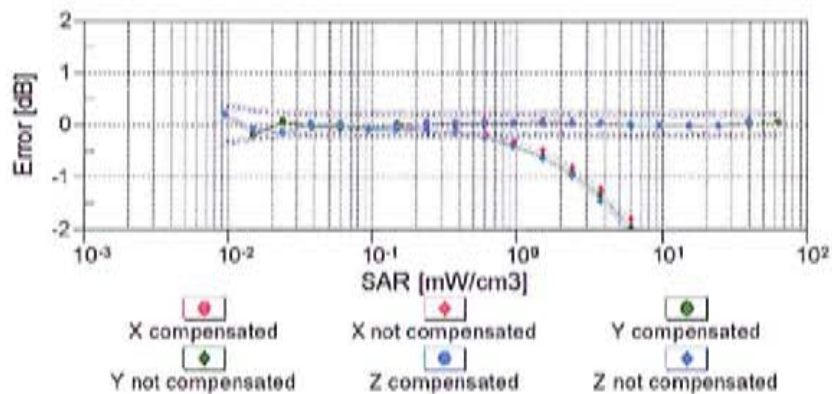
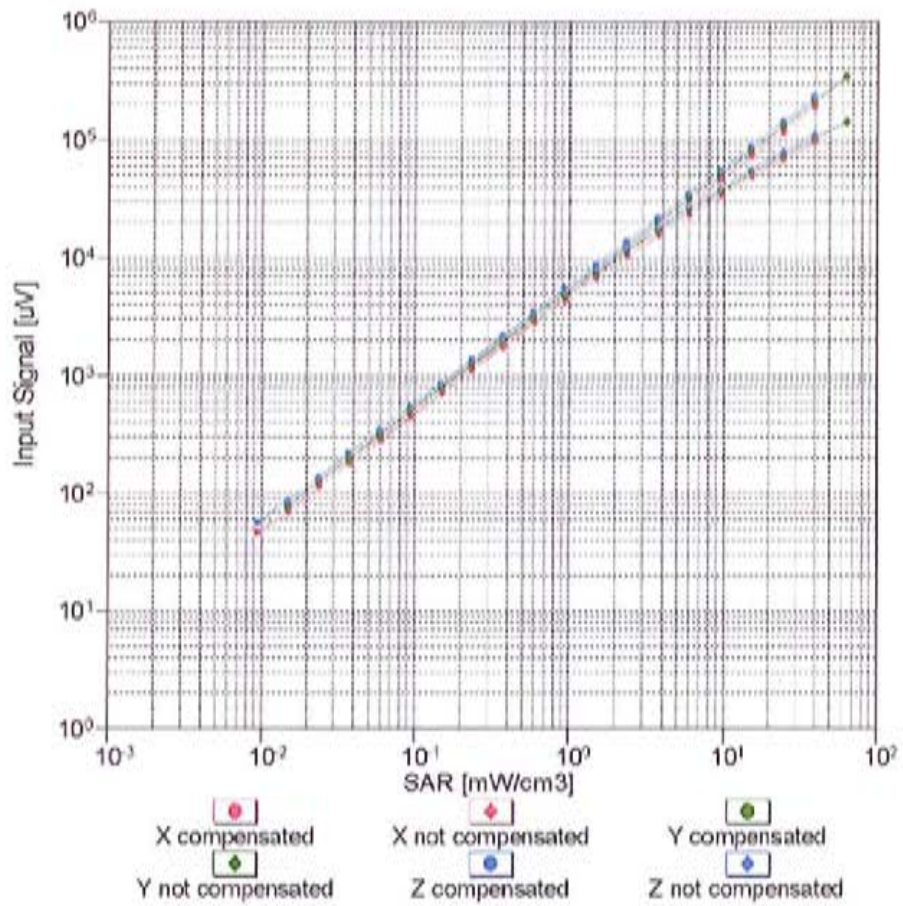

Uncertainty of Linearity Assessment: ± 0.6% (k=2)

Conversion Factor Assessment

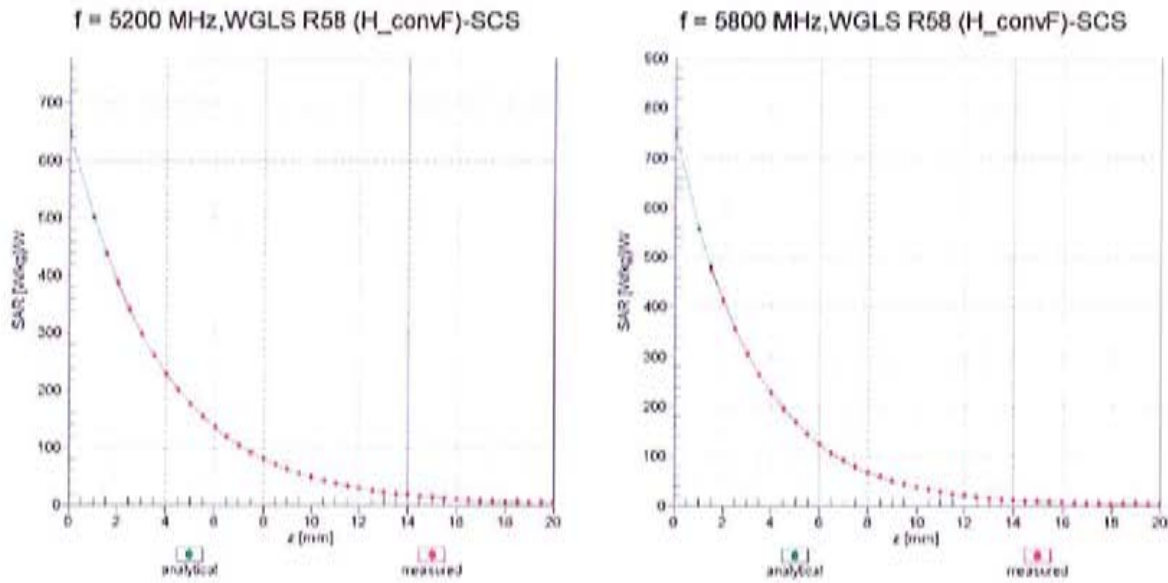

Deviation from Isotropy in Liquid

Error (ϕ, θ), f = 900 MHz

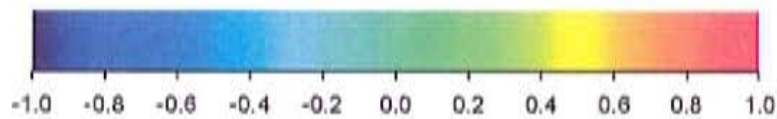
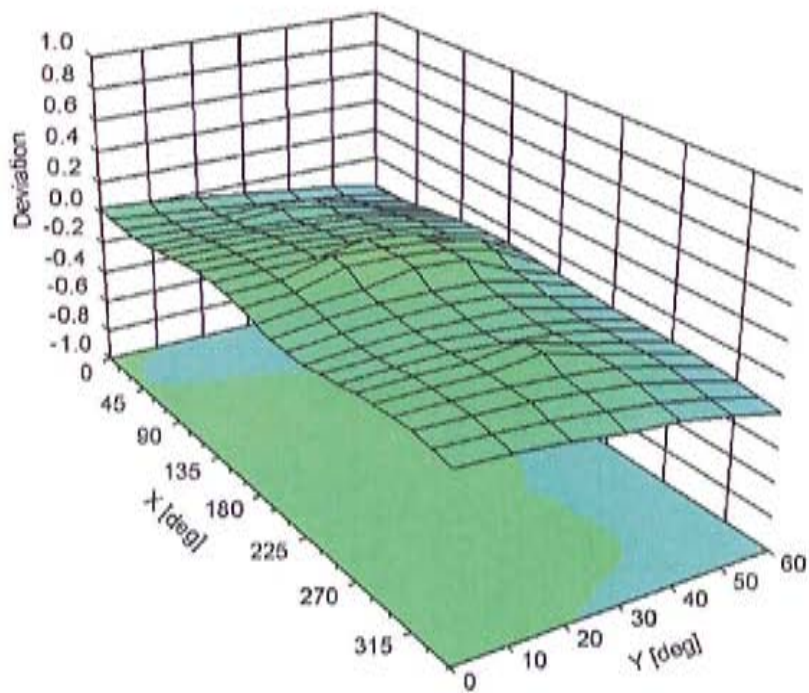

Uncertainty of Spherical Isotropy Assessment: $\pm 2.6\%$ (k=2)

DASY/EASY - Parameters of Probe: EX3DV4 - SN:3728**Other Probe Parameters**

Sensor Arrangement	Triangular
Connector Angle (°)	Not applicable
Mechanical Surface Detection Mode	enabled
Optical Surface Detection Mode	disabled
Probe Overall Length	337 mm
Probe Body Diameter	10 mm
Tip Length	9 mm
Tip Diameter	2.5 mm
Probe Tip to Sensor X Calibration Point	1 mm
Probe Tip to Sensor Y Calibration Point	1 mm
Probe Tip to Sensor Z Calibration Point	1 mm
Recommended Measurement Distance from Surface	2 mm



Accredited by the Swiss Accreditation Service (SAS)
The Swiss Accreditation Service is one of the signatories to the EA
Multilateral Agreement for the recognition of calibration certificates

Accreditation No.: **SCS 108**

Client **Motorola MDB**

Certificate No: **ES3-3184_Mar11**

CALIBRATION CERTIFICATE

Object **ES3DV3 - SN:3184**

Calibration procedure(s) **QA CAL-01.v7, QA CAL-23.v4, QA CAL-25.v3
Calibration procedure for dosimetric E-field probes**

Calibration date: **March 11, 2011**

This calibration certificate documents the traceability to national standards, which realize the physical units of measurements (SI).
The measurements and the uncertainties with confidence probability are given on the following pages and are part of the certificate.

All calibrations have been conducted in the closed laboratory facility: environment temperature (22 ± 3)°C and humidity < 70%.

Calibration Equipment used (M&TE critical for calibration)

Primary Standards	ID	Cal Date (Certificate No.)	Scheduled Calibration
Power meter E4419B	GB41293874	01-Apr-10 (No. 217-01136)	Apr-11
Power sensor E4412A	MY41495277	01-Apr-10 (No. 217-01136)	Apr-11
Power sensor E4412A	MY41498087	01-Apr-10 (No. 217-01136)	Apr-11
Reference 3 dB Attenuator	SN: S5054 (3c)	30-Mar-10 (No. 217-01159)	Mar-11
Reference 20 dB Attenuator	SN: S5086 (20b)	30-Mar-10 (No. 217-01161)	Mar-11
Reference 30 dB Attenuator	SN: S5129 (30b)	30-Mar-10 (No. 217-01160)	Mar-11
Reference Probe ES3DV2	SN: 3013	29-Dec-10 (No. ES3-3013_Dec10)	Dec-11
DAE4	SN: 654	23-Apr-10 (No. DAE4-654_Apr10)	Apr-11
Secondary Standards	ID	Check Date (in house)	Scheduled Check
RF generator HP 8648C	US3642U01700	4-Aug-99 (in house check Oct-09)	In house check: Oct-11
Network Analyzer HP 8753E	US37390585	18-Oct-01 (in house check Oct-10)	In house check: Oct-11

	Name	Function	Signature
Calibrated by:	Jeton Kastrati	Laboratory Technician	
Approved by:	Katja Pokovic	Technical Manager	

Issued: March 16, 2011

This calibration certificate shall not be reproduced except in full without written approval of the laboratory.



Accredited by the Swiss Accreditation Service (SAS)
The Swiss Accreditation Service is one of the signatories to the EA
Multilateral Agreement for the recognition of calibration certificates

Accreditation No.: SCS 108

Glossary:

TSL	tissue simulating liquid
NORM _{x,y,z}	sensitivity in free space
ConvF	sensitivity in TSL / NORM _{x,y,z}
DCP	diode compression point
CF	crest factor (1/duty_cycle) of the RF signal
A, B, C	modulation dependent linearization parameters
Polarization φ	φ rotation around probe axis
Polarization ϑ	ϑ rotation around an axis that is in the plane normal to probe axis (at measurement center), i.e., $\vartheta = 0$ is normal to probe axis

Calibration is Performed According to the Following Standards:

- IEEE Std 1528-2003, "IEEE Recommended Practice for Determining the Peak Spatial-Averaged Specific Absorption Rate (SAR) in the Human Head from Wireless Communications Devices: Measurement Techniques", December 2003
- IEC 62209-1, "Procedure to measure the Specific Absorption Rate (SAR) for hand-held devices used in close proximity to the ear (frequency range of 300 MHz to 3 GHz)", February 2005

Methods Applied and Interpretation of Parameters:

- NORM_{x,y,z}**: Assessed for E-field polarization $\vartheta = 0$ ($f \leq 900$ MHz in TEM-cell; $f > 1800$ MHz: R22 waveguide). NORM_{x,y,z} are only intermediate values, i.e., the uncertainties of NORM_{x,y,z} does not affect the E²-field uncertainty inside TSL (see below ConvF).
- NORM(f)_{x,y,z}** = NORM_{x,y,z} * frequency_response (see Frequency Response Chart). This linearization is implemented in DASY4 software versions later than 4.2. The uncertainty of the frequency response is included in the stated uncertainty of ConvF.
- DCP_{x,y,z}**: DCP are numerical linearization parameters assessed based on the data of power sweep with CW signal (no uncertainty required). DCP does not depend on frequency nor media.
- PAR**: PAR is the Peak to Average Ratio that is not calibrated but determined based on the signal characteristics
- A_{x,y,z}; B_{x,y,z}; C_{x,y,z}** are numerical linearization parameters in dB assessed based on the data of power sweep for specific modulation signal. The parameters do not depend on frequency nor media.
- VR**: VR is the validity range of the calibration related to the average diode voltage or DAE voltage in mV.
- ConvF and Boundary Effect Parameters**: Assessed in flat phantom using E-field (or Temperature Transfer Standard for $f \leq 800$ MHz) and inside waveguide using analytical field distributions based on power measurements for $f > 800$ MHz. The same setups are used for assessment of the parameters applied for boundary compensation (alpha, depth) of which typical uncertainty values are given. These parameters are used in DASY4 software to improve probe accuracy close to the boundary. The sensitivity in TSL corresponds to NORM_{x,y,z} * ConvF whereby the uncertainty corresponds to that given for ConvF. A frequency dependent ConvF is used in DASY version 4.4 and higher which allows extending the validity from ± 50 MHz to ± 100 MHz.
- Spherical isotropy (3D deviation from isotropy)**: in a field of low gradients realized using a flat phantom exposed by a patch antenna.
- Sensor Offset**: The sensor offset corresponds to the offset of virtual measurement center from the probe tip (on probe axis). No tolerance required.

Probe ES3DV3

SN:3184

Manufactured: August 19, 2008
Calibrated: March 11, 2011

Calibrated for DASY/EASY Systems
(Note: non-compatible with DASY2 system!)

DASY/EASY - Parameters of Probe: ES3DV3 - SN:3184

Basic Calibration Parameters

	Sensor X	Sensor Y	Sensor Z	Unc (k=2)
Norm ($\mu\text{V}/(\text{V}/\text{m})^2$) ^A	1.27	1.40	1.27	$\pm 10.1\%$
DCP (mV) ^B	96.8	98.9	99.5	

Modulation Calibration Parameters

UID	Communication System Name	PAR		A dB	B dB	C dB	VR mV	Unc ^E (k=2)
10000	CW	0.00	X	0.00	0.00	1.00	110.8	$\pm 3.0\%$
			Y	0.00	0.00	1.00	117.2	
			Z	0.00	0.00	1.00	107.9	

The reported uncertainty of measurement is stated as the standard uncertainty of measurement multiplied by the coverage factor $k=2$, which for a normal distribution corresponds to a coverage probability of approximately 95%.

^A The uncertainties of NormX,Y,Z do not affect the E^2 -field uncertainty inside TSL (see Pages 5 and 6).

^B Numerical linearization parameter: uncertainty not required.

^E Uncertainty is determined using the max. deviation from linear response applying rectangular distribution and is expressed for the square of the field value.

DASY/EASY - Parameters of Probe: ES3DV3 - SN:3184

Calibration Parameter Determined in Head Tissue Simulating Media

f (MHz) ^c	Relative Permittivity ^f	Conductivity (S/m) ^f	ConvF X	ConvF Y	ConvF Z	Alpha	Depth (mm)	Unct. (k=2)
835	41.5	0.90	6.11	6.11	6.11	1.00	1.04	± 12.0 %
1810	40.0	1.40	5.11	5.11	5.11	0.93	1.08	± 12.0 %
1950	40.0	1.40	4.93	4.93	4.93	0.96	1.07	± 12.0 %
2450	39.2	1.80	4.48	4.48	4.48	0.73	1.28	± 12.0 %

^c Frequency validity of ± 100 MHz only applies for DASY v4.4 and higher (see Page 2), else it is restricted to ± 50 MHz. The uncertainty is the RSS of the ConvF uncertainty at calibration frequency and the uncertainty for the indicated frequency band.

^f At frequencies below 3 GHz, the validity of tissue parameters (ϵ and σ) can be relaxed to ± 10% if liquid compensation formula is applied to measured SAR values. At frequencies above 3 GHz, the validity of tissue parameters (ϵ and σ) is restricted to ± 5%. The uncertainty is the RSS of the ConvF uncertainty for indicated target tissue parameters.

DASY/EASY - Parameters of Probe: ES3DV3- SN:3184

Calibration Parameter Determined in Body Tissue Simulating Media

f (MHz) ^G	Relative Permittivity ^F	Conductivity (S/m) ^F	ConvF X	ConvF Y	ConvF Z	Alpha	Depth (mm)	Unct. (k=2)
835	55.2	0.97	6.10	6.10	6.10	1.00	1.00	± 12.0 %
1810	53.3	1.52	4.90	4.90	4.90	0.87	1.26	± 12.0 %
1950	53.3	1.52	4.86	4.86	4.86	0.73	1.38	± 12.0 %
2450	52.7	1.95	4.33	4.33	4.33	1.00	1.03	± 12.0 %

^G Frequency validity of ± 100 MHz only applies for DASY v4.4 and higher (see Page 2), else it is restricted to ± 50 MHz. The uncertainty is the RSS of the ConvF uncertainty at calibration frequency and the uncertainty for the indicated frequency band.

^F At frequencies below 3 GHz, the validity of tissue parameters (ϵ and σ) can be relaxed to ± 10% if liquid compensation formula is applied to measured SAR values. At frequencies above 3 GHz, the validity of tissue parameters (ϵ and σ) is restricted to ± 5%. The uncertainty is the RSS of the ConvF uncertainty for indicated target tissue parameters.

Frequency Response of E-Field (TEM-Cell:ifi110 EXX, Waveguide: R22)

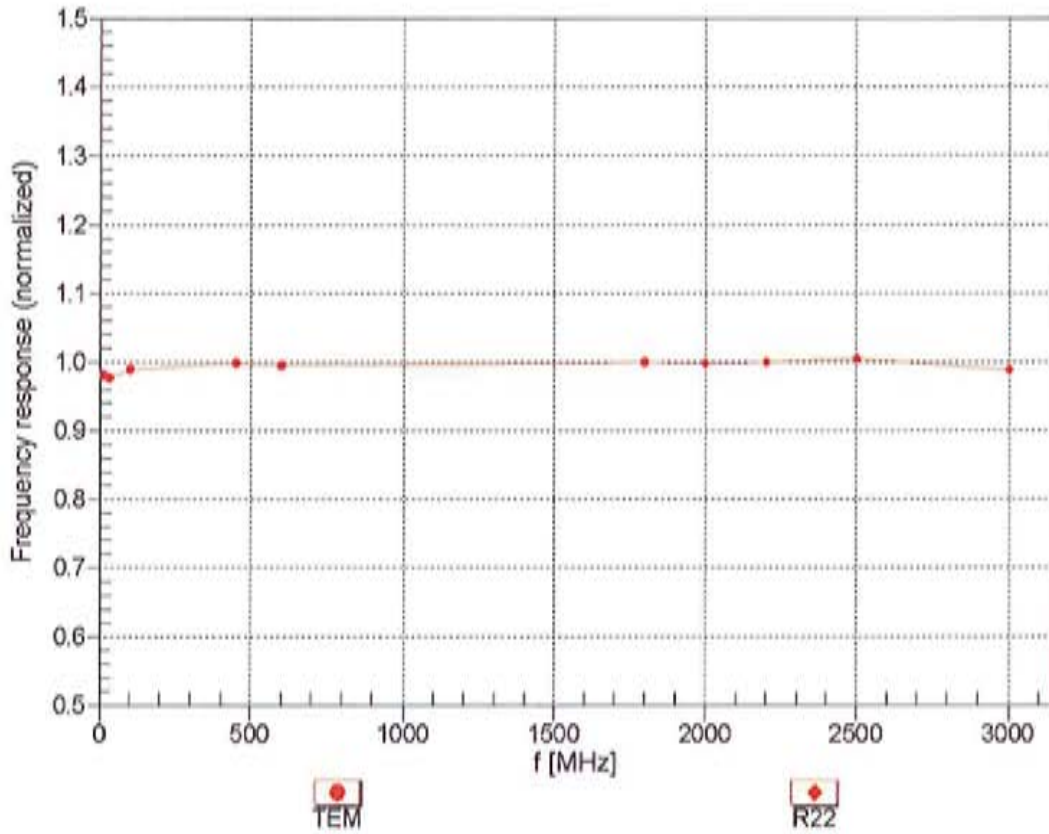

Uncertainty of Frequency Response of E-field: $\pm 6.3\%$ (k=2)

Receiving Pattern (ϕ), $\theta = 0^\circ$

f=600 MHz, TEM

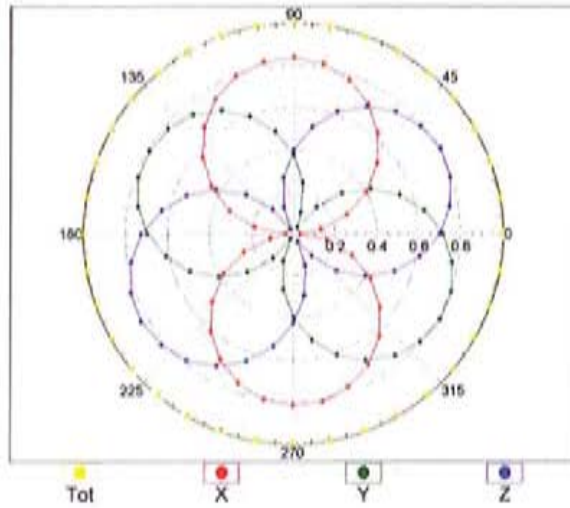

f=1800 MHz, R22

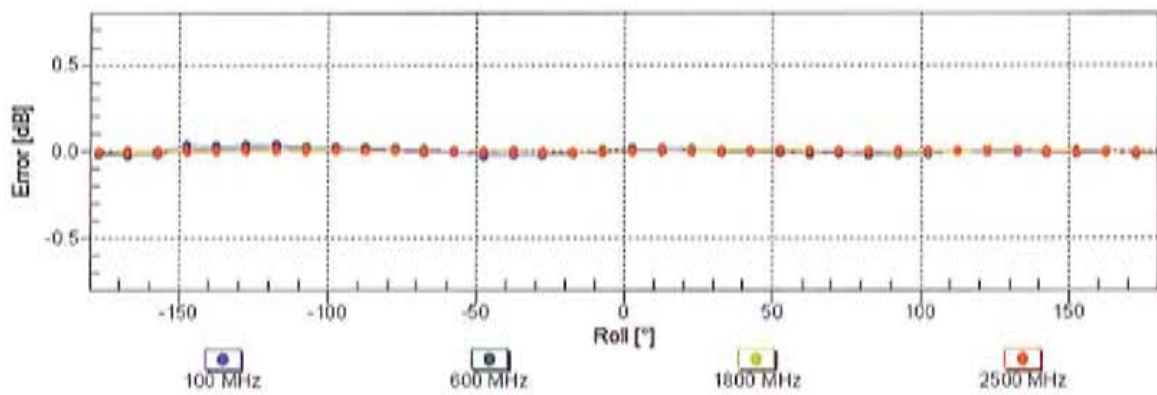
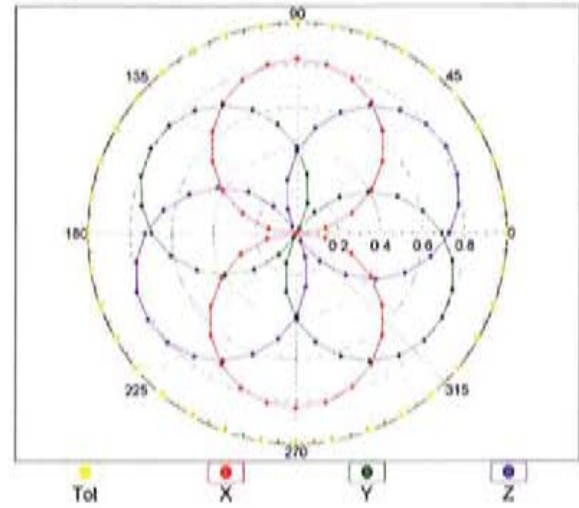

Uncertainty of Axial Isotropy Assessment: $\pm 0.5\%$ ($k=2$)

Dynamic Range f(SAR_{head}) (TEM cell , f = 900 MHz)

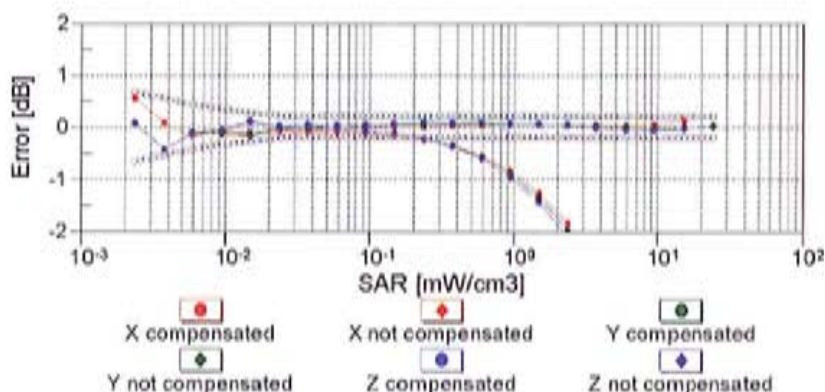
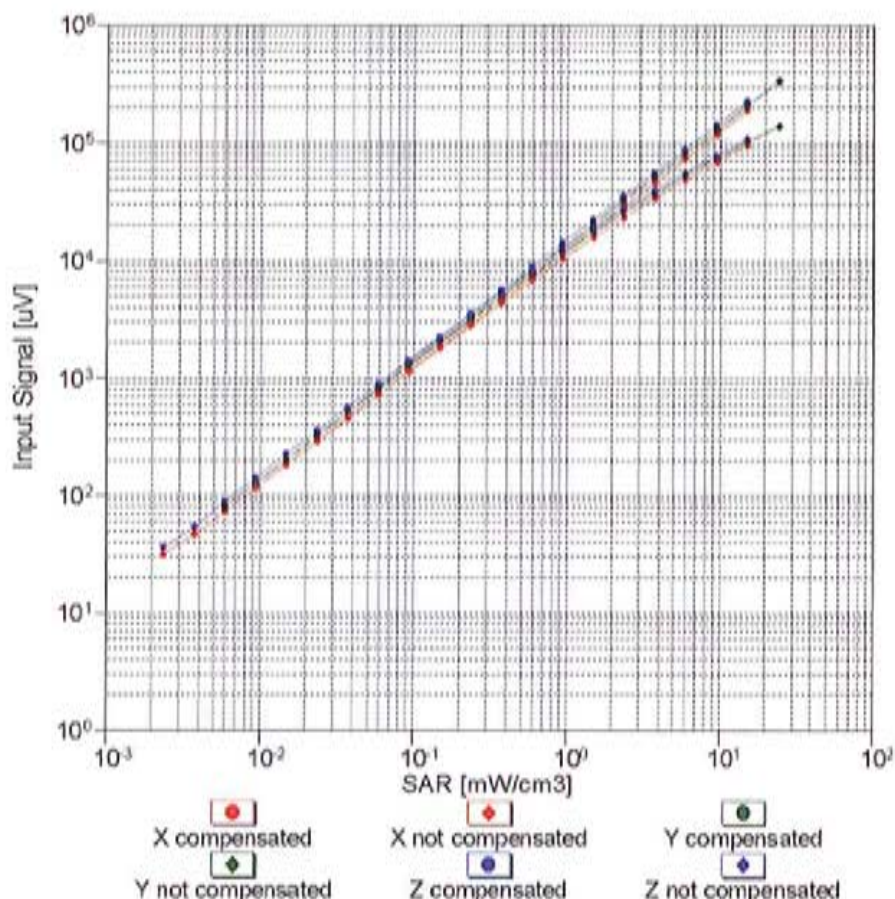

Uncertainty of Linearity Assessment: ± 0.6% (k=2)

Conversion Factor Assessment

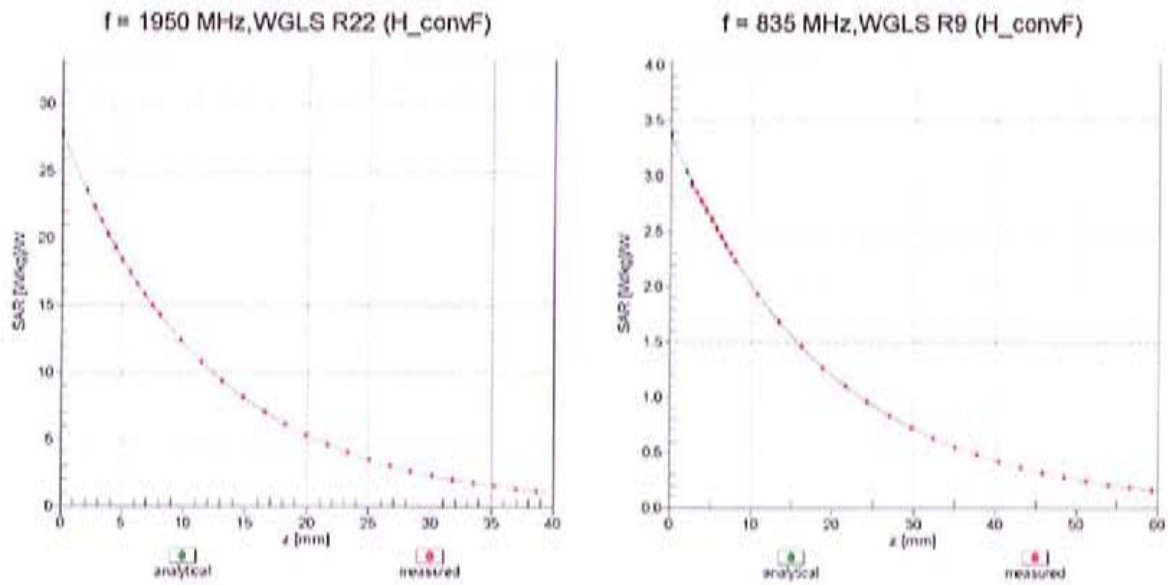

Deviation from Isotropy in Liquid Error (ϕ, θ), f = 900 MHz

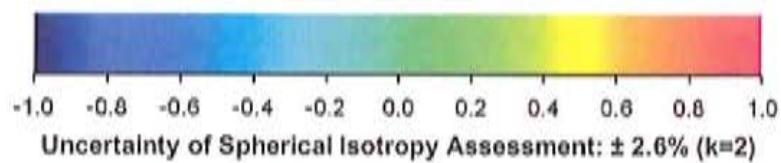
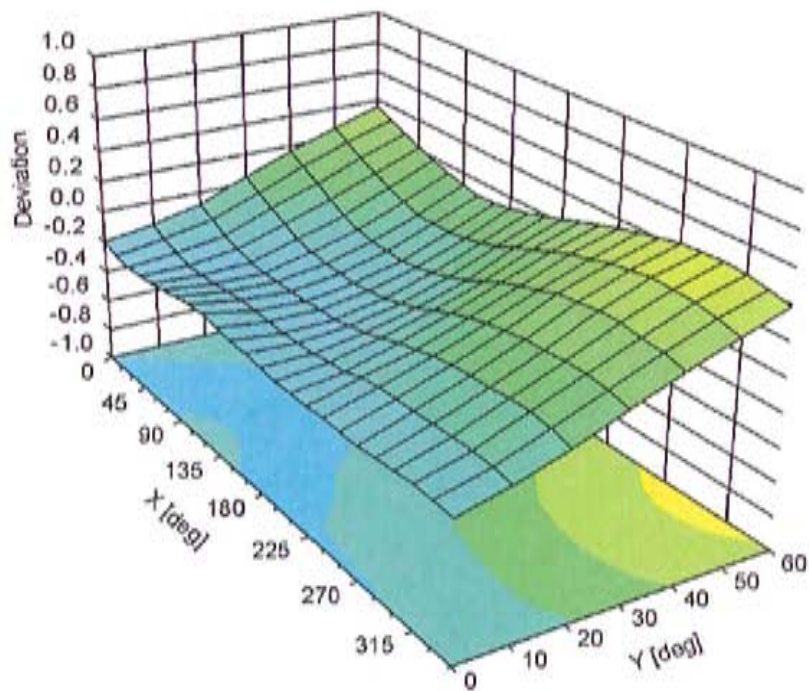

DASY/EASY - Parameters of Probe: ES3DV3 - SN:3184**Other Probe Parameters**

Sensor Arrangement	Triangular
Connector Angle (°)	Not applicable
Mechanical Surface Detection Mode	enabled
Optical Surface Detection Mode	disabled
Probe Overall Length	337 mm
Probe Body Diameter	10 mm
Tip Length	10 mm
Tip Diameter	4 mm
Probe Tip to Sensor X Calibration Point	2 mm
Probe Tip to Sensor Y Calibration Point	2 mm
Probe Tip to Sensor Z Calibration Point	2 mm
Recommended Measurement Distance from Surface	3 mm



Accredited by the Swiss Accreditation Service (SAS)
The Swiss Accreditation Service is one of the signatories to the EA
Multilateral Agreement for the recognition of calibration certificates

Accreditation No.: **SCS 108**

Client **Motorola MDb**

Certificate No: **ES3-3115_Jan11**

CALIBRATION CERTIFICATE

Object **ES3DV3 - SN:3115**

Calibration procedure(s) **QA CAL-01.v7, QA CAL-23.v4 and QA CAL-25.v3
Calibration procedure for dosimetric E-field probes**

Calibration date: **January 12, 2011**

This calibration certificate documents the traceability to national standards, which realize the physical units of measurements (SI).
The measurements and the uncertainties with confidence probability are given on the following pages and are part of the certificate.

All calibrations have been conducted in the closed laboratory facility: environment temperature (22 ± 3)°C and humidity < 70%.

Calibration Equipment used (M&TE critical for calibration)

Primary Standards	ID #	Cal Date (Certificate No.)	Scheduled Calibration
Power meter E4419B	GB41293874	1-Apr-10 (No. 217-01136)	Apr-11
Power sensor E4412A	MY41495277	1-Apr-10 (No. 217-01136)	Apr-11
Power sensor E4412A	MY41498087	1-Apr-10 (No. 217-01136)	Apr-11
Reference 3 dB Attenuator	SN: S5054 (3c)	30-Mar-10 (No. 217-01159)	Mar-11
Reference 20 dB Attenuator	SN: S5086 (20b)	30-Mar-10 (No. 217-01161)	Mar-11
Reference 30 dB Attenuator	SN: S5129 (30b)	30-Mar-10 (No. 217-01160)	Mar-11
Reference Probe ES3DV2	SN: 3013	29-Dec-10 (No. ES3-3013_Dec10)	Dec-11
DAE4	SN: 660	20-Apr-10 (No. DAE4-660_Apr10)	Apr-11

Secondary Standards	ID #	Check Date (in house)	Scheduled Check
RF generator HP 8648C	US3642U01700	4-Aug-99 (in house check Oct-09)	In house check: Oct-11
Network Analyzer HP 8753E	US37390585	18-Oct-01 (in house check Oct-10)	In house check: Oct-11

	Name	Function	Signature
Calibrated by:	Jeton Kastrali	Laboratory Technician	
Approved by:	Katja Pokovic	Technical Manager	

Issued: January 13, 2011

This calibration certificate shall not be reproduced except in full without written approval of the laboratory.



Accredited by the Swiss Accreditation Service (SAS)
The Swiss Accreditation Service is one of the signatories to the EA
Multilateral Agreement for the recognition of calibration certificates

Accreditation No.: **SCS 108**

Glossary:

TSL	tissue simulating liquid
NORM _{x,y,z}	sensitivity in free space
ConvF	sensitivity in TSL / NORM _{x,y,z}
DCP	diode compression point
CF	crest factor (1/duty_cycle) of the RF signal
A, B, C	modulation dependent linearization parameters
Polarization φ	φ rotation around probe axis
Polarization ϑ	ϑ rotation around an axis that is in the plane normal to probe axis (at measurement center), i.e., $\vartheta = 0$ is normal to probe axis

Calibration is Performed According to the Following Standards:

- IEEE Std 1528-2003, "IEEE Recommended Practice for Determining the Peak Spatial-Averaged Specific Absorption Rate (SAR) in the Human Head from Wireless Communications Devices: Measurement Techniques", December 2003
- IEC 62209-1, "Procedure to measure the Specific Absorption Rate (SAR) for hand-held devices used in close proximity to the ear (frequency range of 300 MHz to 3 GHz)", February 2005

Methods Applied and Interpretation of Parameters:

- NORM_{x,y,z}**: Assessed for E-field polarization $\vartheta = 0$ ($f \leq 900$ MHz in TEM-cell; $f > 1800$ MHz: R22 waveguide). NORM_{x,y,z} are only intermediate values, i.e., the uncertainties of NORM_{x,y,z} does not effect the E^2 -field uncertainty inside TSL (see below *ConvF*).
- NORM(f)_{x,y,z} = NORM_{x,y,z} * frequency_response** (see Frequency Response Chart). This linearization is implemented in DASY4 software versions later than 4.2. The uncertainty of the frequency response is included in the stated uncertainty of *ConvF*.
- DCP_{x,y,z}**: DCP are numerical linearization parameters assessed based on the data of power sweep with CW signal (no uncertainty required). DCP does not depend on frequency nor media.
- A_{x,y,z}; B_{x,y,z}; C_{x,y,z}; VR_{x,y,z}; A, B, C** are numerical linearization parameters assessed based on the data of power sweep for specific modulation signal. The parameters do not depend on frequency nor media. VR is the maximum calibration range expressed in RMS voltage across the diode.
- ConvF and Boundary Effect Parameters**: Assessed in flat phantom using E-field (or Temperature Transfer Standard for $f \leq 800$ MHz) and inside waveguide using analytical field distributions based on power measurements for $f > 800$ MHz. The same setups are used for assessment of the parameters applied for boundary compensation (alpha, depth) of which typical uncertainty values are given. These parameters are used in DASY4 software to improve probe accuracy close to the boundary. The sensitivity in TSL corresponds to **NORM_{x,y,z} * ConvF** whereby the uncertainty corresponds to that given for *ConvF*. A frequency dependent *ConvF* is used in DASY version 4.4 and higher which allows extending the validity from ± 50 MHz to ± 100 MHz.
- Spherical isotropy (3D deviation from isotropy)**: in a field of low gradients realized using a flat phantom exposed by a patch antenna.
- Sensor Offset**: The sensor offset corresponds to the offset of virtual measurement center from the probe tip (on probe axis). No tolerance required.

Probe ES3DV3

SN:3115

Manufactured:	March 6, 2006
Last calibrated:	January 19, 2010
Recalibrated:	January 12, 2011

Calibrated for DASY/EASY Systems

(Note: non-compatible with DASY2 system!)

DASY/EASY - Parameters of Probe: ES3DV3 SN:3115

Basic Calibration Parameters

	Sensor X	Sensor Y	Sensor Z	Unc (k=2)
Norm ($\mu\text{V}/(\text{V}/\text{m})^2$) ^A	1.29	1.30	1.18	± 10.1%
DCP (mV) ^B	100.2	102.3	101.3	

Modulation Calibration Parameters

UID	Communication System Name	PAR		A dB	B dBuV	C	VR mV	Unc ^E (k=2)
10000	CW	0.00	X	0.00	0.00	1.00	113.4	± 2.4 %
			Y	0.00	0.00	1.00	150.5	
			Z	0.00	0.00	1.00	142.6	

The reported uncertainty of measurement is stated as the standard uncertainty of measurement multiplied by the coverage factor k=2, which for a normal distribution corresponds to a coverage probability of approximately 95%.

^A The uncertainties of NormX,Y,Z do not affect the E²-field uncertainty inside TSL (see Pages 5 and 6).

^B Numerical linearization parameter: uncertainty not required.

^E Uncertainty is determined using the maximum deviation from linear response applying recatangular distribution and is expressed for the square of the field value.

DASY/EASY - Parameters of Probe: ES3DV3 SN:3115

Calibration Parameter Determined in Head Tissue Simulating Media

f [MHz]	Validity [MHz] ^c	Permittivity	Conductivity	ConvF X	ConvF Y	ConvF Z	Alpha	Depth Unc (k=2)
835	± 50 / ± 100	41.5 ± 5%	0.90 ± 5%	5.87	5.87	5.87	0.34	1.74 ± 11.0%
1810	± 50 / ± 100	40.0 ± 5%	1.40 ± 5%	5.02	5.02	5.02	0.43	1.62 ± 11.0%
1950	± 50 / ± 100	40.0 ± 5%	1.40 ± 5%	4.80	4.80	4.80	0.62	1.36 ± 11.0%
2450	± 50 / ± 100	39.2 ± 5%	1.80 ± 5%	4.39	4.39	4.39	0.94	1.13 ± 11.0%

^c The validity of ± 100 MHz only applies for DASY v4.4 and higher (see Page 2). The uncertainty is the RSS of the ConvF uncertainty at calibration frequency and the uncertainty for the indicated frequency band.

DASY/EASY - Parameters of Probe: ES3DV3 SN:3115

Calibration Parameter Determined in Body Tissue Simulating Media

f [MHz]	Validity [MHz] ^c	Permittivity	Conductivity	ConvF X	ConvF Y	ConvF Z	Alpha	Depth Unc (k=2)
835	± 50 / ± 100	55.2 ± 5%	0.97 ± 5%	5.88	5.88	5.88	0.57	1.41 ± 11.0%
1810	± 50 / ± 100	53.3 ± 5%	1.52 ± 5%	4.61	4.61	4.61	0.33	2.26 ± 11.0%
1950	± 50 / ± 100	53.3 ± 5%	1.52 ± 5%	4.57	4.57	4.57	0.36	2.19 ± 11.0%
2450	± 50 / ± 100	52.7 ± 5%	1.95 ± 5%	4.12	4.12	4.12	0.99	0.75 ± 11.0%

^c The validity of ± 100 MHz only applies for DASY v4.4 and higher (see Page 2). The uncertainty is the RSS of the ConvF uncertainty at calibration frequency and the uncertainty for the indicated frequency band.

Frequency Response of E-Field

(TEM-Cell:ifi110 EXX, Waveguide: R22)

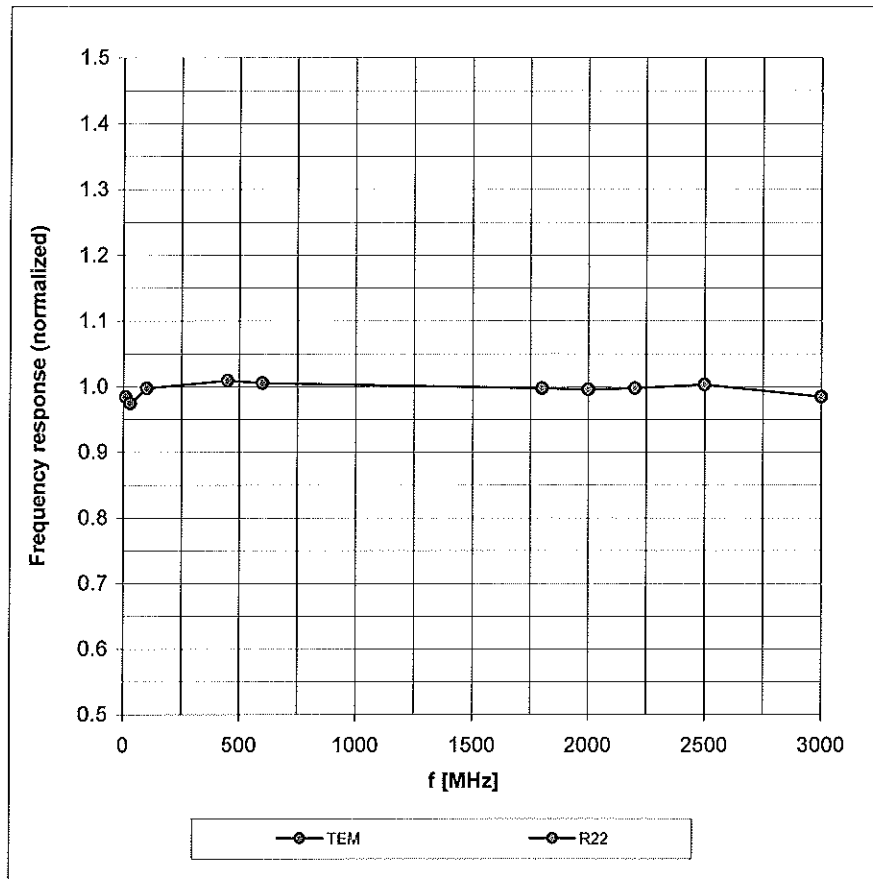

Uncertainty of Frequency Response of E-field: $\pm 6.3\%$ ($k=2$)

Receiving Pattern (ϕ), $\vartheta = 0^\circ$

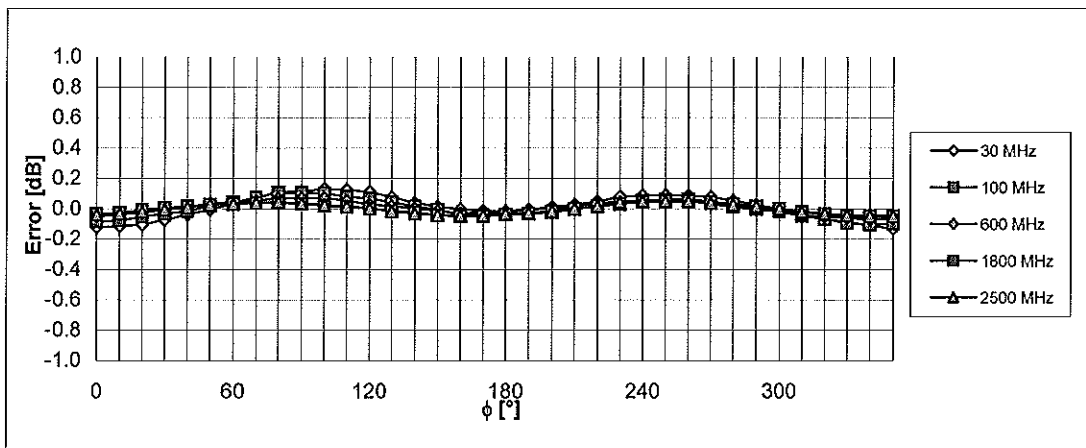
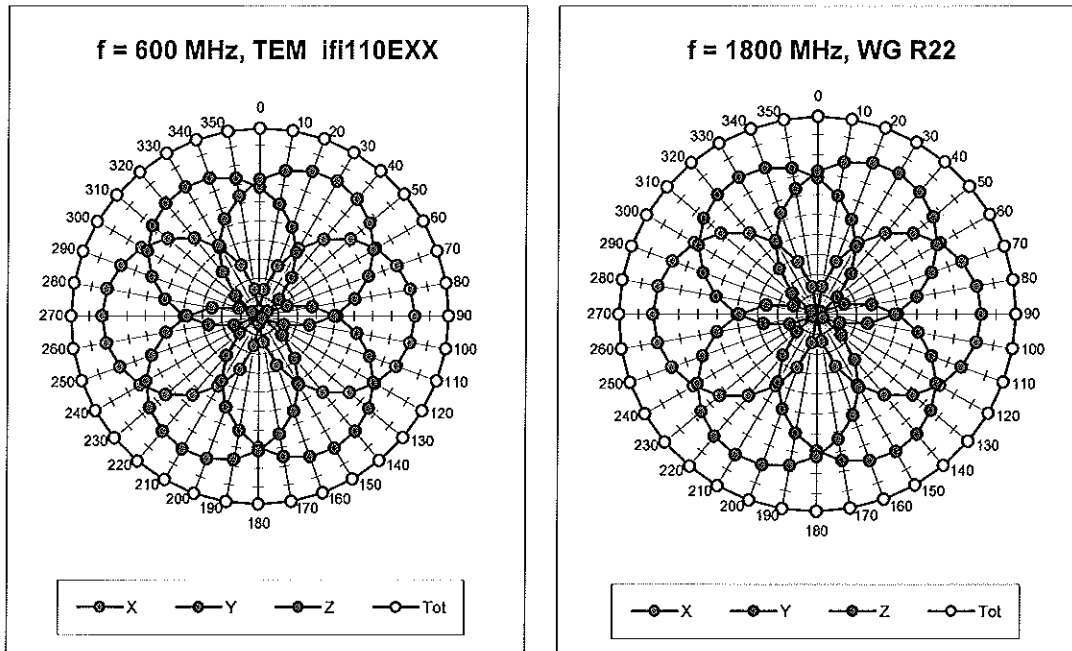

Uncertainty of Axial Isotropy Assessment: $\pm 0.5\%$ ($k=2$)

Dynamic Range f(SAR_{head}) (TEM cell, f = 900 MHz)

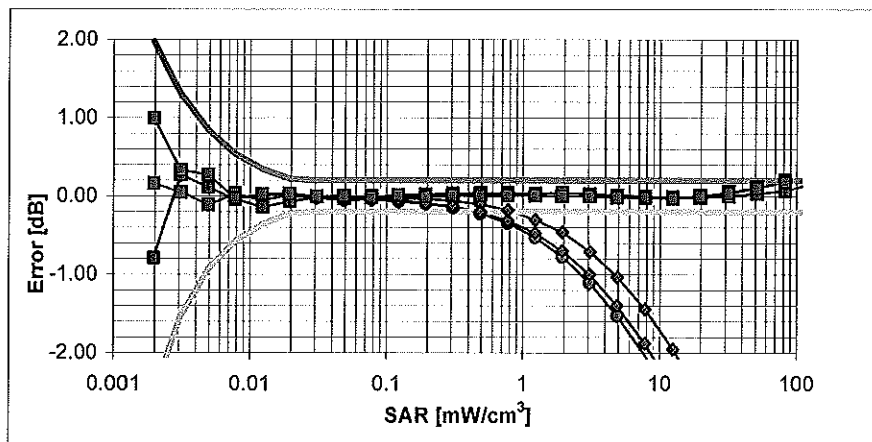
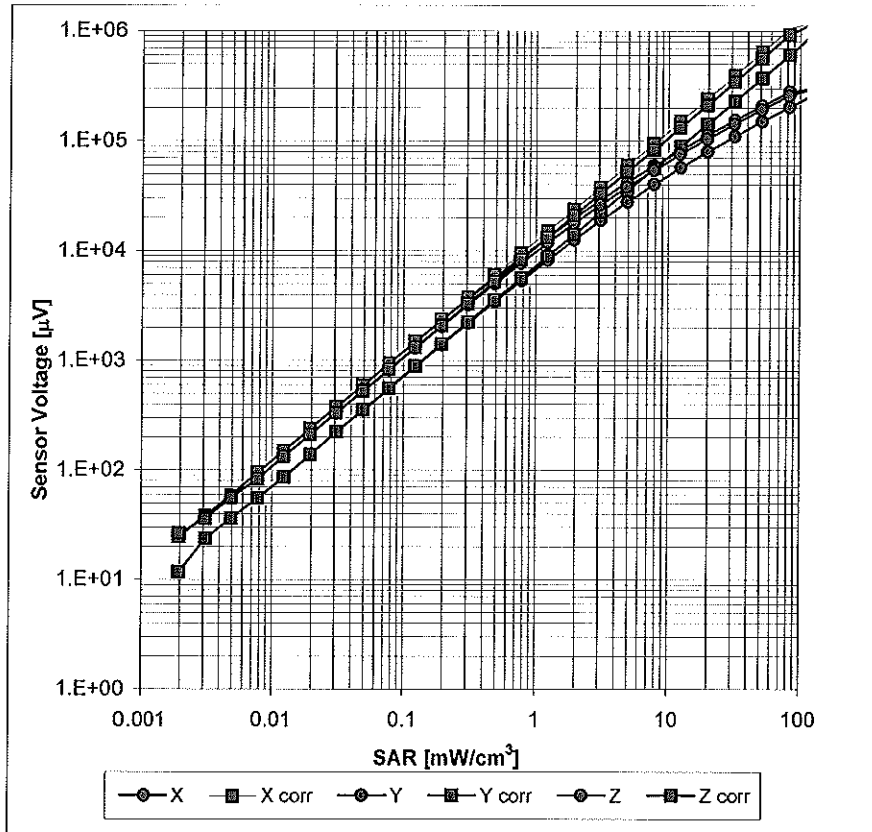

Uncertainty of Linearity Assessment: $\pm 0.6\%$ (k=2)

Conversion Factor Assessment

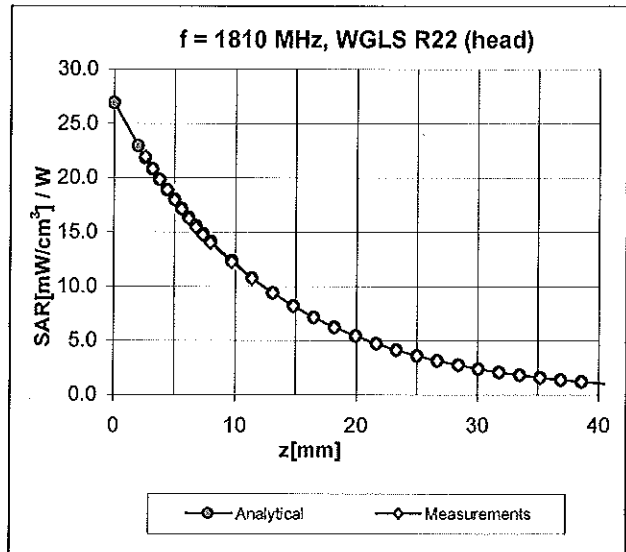
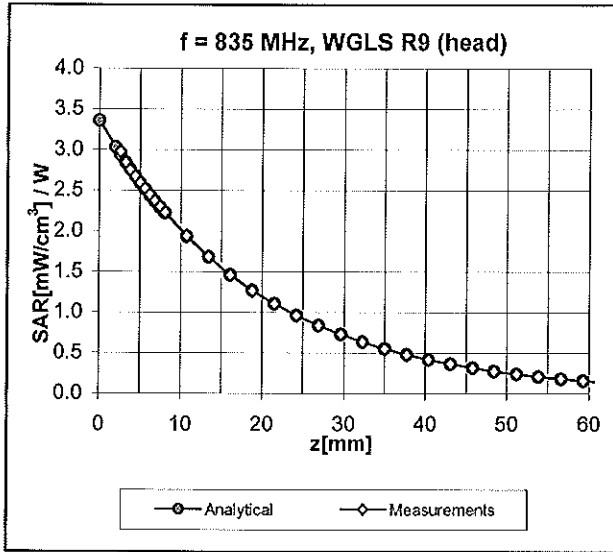

Deviation from Isotropy in HSL

Error (ϕ , θ), f = 900 MHz

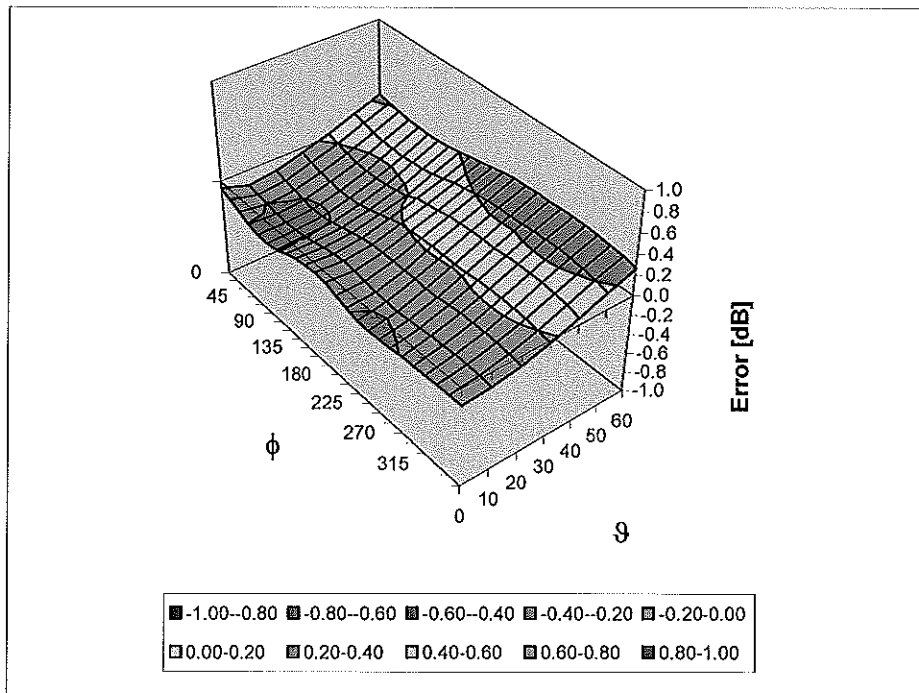

Uncertainty of Spherical Isotropy Assessment: $\pm 2.6\%$ (k=2)

Other Probe Parameters

Sensor Arrangement	Triangular
Connector Angle (°)	Not applicable
Mechanical Surface Detection Mode	enabled
Optical Surface Detection Mode	disabled
Probe Overall Length	337 mm
Probe Body Diameter	10 mm
Tip Length	10 mm
Tip Diameter	4 mm
Probe Tip to Sensor X Calibration Point	2 mm
Probe Tip to Sensor Y Calibration Point	2 mm
Probe Tip to Sensor Z Calibration Point	2 mm
Recommended Measurement Distance from Surface	3 mm