



MOTOROLA

Portable Cellular Phone Class II SAR Test Report

Motorola Mobile Devices
Tests Requested By: 600 N. US Highway 45
 Libertyville, IL 60048
Test Report #: 24745-1F Rev. A
Date of Report: 19 Oct, 2011
Date of Test: July 26 – 27, 2001 and Oct 7 – 14, 2011
FCC ID #: IHDP56MA2
Generic Name: MOC22
 Motorola Mobile Devices Business ADR Test Services Laboratory
Test Laboratory: 600 N. US Highway 45
 Libertyville, IL 60048
Report Author: Steven Hauswirth
 Distinguished Member of the Technical Staff
 This laboratory is accredited to ISO/IEC 17025-2005 to perform the following tests:

Accreditation:



Testing Laboratory
 No. 2404

Tests:

Electromagnetic Specific Absorption Rate

Procedures:

IEC 62209-1

RSS-102

IEEE 1528 - 2003

FCC OET Bulletin 65 (including Supplement C)

Australian Communications Authority Radio

Communications (Electromagnetic Radiation – Human Exposure) Standard 2003

CENELEC EN 50360

ARIB Std. T-56 (2002)

On the following products or types of products:

On the following products or types of products: Wireless Communications Devices (Examples): Two Way Radios; Portable Phones (including Cellular, Licensed Non-Broadcast and PCS); Low Frequency Readers; and Pagers

Statement of Compliance:

Motorola declares under its sole responsibility that the portable cellular telephone model to which this declaration relates, is in conformity with the appropriate General Population/Uncontrolled RF exposure standards, recommendations and guidelines (FCC 47 CFR §2.1093) as well as with CENELEC en50360:2001 and ANSI / IEEE C95.1. It also declares that the product was tested in accordance with IEEE 1528 / CENELEC EN62209-1 (2006), as well as other appropriate measurement standards, guidelines and recommended practices. Any deviations from these standards, guidelines and recommended practices are noted below:

(none)

©Motorola Mobility, Inc. 2011

This test report shall not be reproduced except in full, without written approval of the laboratory. The results and statements contained herein relate only to the items tested. The names of individuals involved may be mentioned only in connection with the statements or results from this report. Motorola encourages all feedback, both positive and negative, on this test report.

Table of Contents

1. Introduction	3
2. Description of the Device Under Test	3
2.1 Antenna description	3
2.1 Antenna description	3
2.2 Device description	4
2.3 Device Conducted Power Measurements	5
2.3.1 Measured GSM mode Conducted Power Levels	5
2.3.2 Measured WCDA mode Conducted Power Levels	6
2.3.3 Wi-Fi 802.11 modes	7
2.3.4 Power limit reduction scenes	8
3. Test Equipment Used	9
3.1 Dosimetric System	9
3.2 Additional Equipment	9
4. Electrical parameters of the tissue simulating liquid	10
5. System Accuracy Verification	11
6. Test Results	12
6.1 Head Adjacent Test Results	12
6.2 Body Worn Test Results	15
6.3 Mobile Hotspot Test Results	18
6.4 Description and Evaluation of Simultaneous Transmitters	22
References	25
Appendix 1: SAR distribution comparison for the system accuracy verification	
Appendix 2: SAR distribution plots for Phantom Head Adjacent Use	
Appendix 3: SAR distribution plots for Body Worn Configuration	
Appendix 4: SAR distribution plots for Mobile Hotspot Configuration	
Appendix 5: SAR distribution plots for Simultaneous Transmission Evaluation	
Appendix 6: Measurement Uncertainty Budget	
Appendix 7: Probe Calibration Certificate	
Appendix 8: Dipole Characterization Certificate	

Revision History

Revision Version	Date	Notes
Rev. 0	Oct-18-2011	Initial report release.
Rev. A	Oct-19-2011	Updated EDGE average power levels Harmonized WiFi Power in various sections

1. Introduction

The Motorola Mobile Devices Business ADR Test Services Laboratory has performed measurements of the maximum potential exposure to the user of the portable cellular phone covered by this test report. The Specific Absorption Rate (SAR) of this product was measured. The portable cellular phone was tested in accordance with [1], [4] and [5]. The SAR values measured for the portable cellular phone are below the maximum recommended levels of 1.6 W/kg in a 1g average set in [3] and 2.0W/kg in a 10g average set in [2].

For ANSI / IEEE C95.1 (1g), the final stand-alone SAR reading for this are shown below. These measurements were performed using a Dasy4™ v4.7 system manufactured by Schmid & Partner Engineering AG (SPEAG), of Zurich Switzerland.

Transmit Band	Head SAR (1 g ^w /kg)	Body SAR (1 g ^w /kg)	Mobile Hotspot SAR (1 g ^w /kg)
GSM 850	0.37	0.54	1.14
WCDMA 850	0.37	0.75	0.67
GSM 1900	0.47	0.39	0.59
WCDMA 1900	0.90	0.76	1.32
Wi-Fi 2.45 GHz	0.55	0.22	0.45

2. Description of the Device Under Test

2.1 Antenna description

Main Antenna (WCDMA/GSM)

Type	Internal	
Location	Back Surface, Bottom of the Phone	
Dimensions	Length	56 mm
	Width	10 mm

WiFi / Bluetooth Antenna

Type	Internal	
Location	Back Surface, Leftt Edge of the Phone	
Dimensions	Length	1 mm
	Width	18.4 mm

2.2 Device description

Serial Number(s)	356472040000268 (Conducted power measurements and SAR testing of GSM and WCDMA modes) 356472040014364 (Wi-Fi / Bluetooth conducted power measurements)
Production Unit or Identical Prototype (47 CFR §2.908)	Identical Prototype
Device Category	Portable

Mode(s) of Operation	Modulation Mode(s)	Maximum Output Power Setting	Duty Cycle	Transmitting Frequency Range(s)
GSM 850	GMSK	33.0 dBm	1:8	824.2 - 848.8 MHz
GSM 1900	GMSK	30.0 dBm	1:8	1850.2 - 1909.8 MHz
WCDMA 850	QPSK	24.0 dBm	1:1	826.4 - 846.6 MHz
WCDMA 1900	QPSK	24.0 dBm	1:1	1852.4 - 1907.6 MHz
Wi-Fi 802.11b/g/n	BPSK	19.17 dBm	1:1	2412.0 - 2462.5 MHz
Bluetooth	GFSK	9.57 dBm	1:1	2402.0 - 2483.5 MHz

GSM Data Functionality	GPRS/EDGE Class 12 (4 uplink timeslots; 4 downlink timeslots; 5 total timeslots per frame)
	Class B (DTM not supported)

Mode(s) of Operation	GPRS/EDGE 850				GPRS/EDGE 1900			
Modulation	GMSK				GMSK			
Maximum Output Power Setting (dBm)	33.0	31.0	29.0	28.0	30.0	28.0	26.0	25.0
Time Average Output Power Setting (dBm)	24.0	25.0	24.7	25.0	21.0	22.0	21.7	22.0
Duty Cycle	1:8	2:8	3:8	4:8	1:8	2:8	3:8	4:8
Transmitting Frequency Range(s)	824.2 - 848.8 MHz				1850.2 - 1909.8 MHz			

Mode(s) of Operation	EDGE 850				EDGE 1900			
Modulation	8PSK				8PSK			
Maximum Output Power Setting (dBm)	28.0	26.0	24.0	23.0	27.0	26.0	24.0	23.0
Time Average Output Power Setting (dBm)	19.0	20.0	19.7	20.0	18.0	20.0	19.7	20.0
Duty Cycle	1:8	2:8	3:8	4:8	1:8	2:8	3:8	4:8
Transmitting Frequency Range(s)	824.2 - 848.8 MHz				1850.2 - 1909.8 MHz			

2.3 Device Conducted Power Measurements

2.3.1 Measured GSM Mode Conducted Power Levels

Band	Channel	Peak Conducted power (dBm) for GSM modes								
		GMSK <i>CS Voice</i> (1 Slot)	GMSK <i>PS Data</i> (1 Slots)	GMSK <i>PS Data</i> (2 Slots)	GMSK <i>PS Data</i> (3 Slots)	GMSK <i>PS Data</i> (4 Slots)	8-PSK <i>PS Data</i> (1 Slots)	8-PSK <i>PS Data</i> (2 Slots)	8-PSK <i>PS Data</i> (3 Slots)	8-PSK <i>PS Data</i> (4 Slots)
850	128	33.18	33.20	30.84	28.87	28.00	28.11	25.85	23.85	23.08
	190	32.99	32.96	30.86	28.56	27.65	27.71	25.56	23.66	22.70
	251	32.75	32.83	30.47	28.55	27.72	27.64	25.78	23.52	22.75
1900	512	30.17	30.10	28.06	25.96	24.96	27.15	26.12	24.07	22.92
	661	30.11	29.96	27.87	25.83	24.46	26.72	26.10	23.81	22.71
	810	29.94	29.83	27.90	25.80	24.81	26.72	26.03	23.74	22.67

Band	Channel	Time Averaged Conducted power (dBm) for GSM modes								
		GMSK <i>CS Voice</i> (1 Slot)	GMSK <i>PS Data</i> (1 Slots)	GMSK <i>PS Data</i> (2 Slots)	GMSK <i>PS Data</i> (3 Slots)	GMSK <i>PS Data</i> (4 Slots)	8-PSK <i>PS Data</i> (1 Slots)	8-PSK <i>PS Data</i> (2 Slots)	8-PSK <i>PS Data</i> (3 Slots)	8-PSK <i>PS Data</i> (4 Slots)
850	128	24.18	24.20	24.84	24.61	25.00	19.11	19.85	19.59	20.08
	190	23.99	23.96	24.86	24.30	24.65	18.71	19.56	19.40	19.70
	251	23.75	23.83	24.47	24.29	24.72	18.64	19.78	19.26	19.75
1900	512	21.17	21.10	22.06	21.70	21.96	18.15	20.12	19.81	19.92
	661	21.11	20.96	21.87	21.57	21.46	17.72	20.10	19.55	19.71
	810	20.94	20.83	21.90	21.54	21.81	17.72	20.03	19.48	19.67

2.3.2 WCDMA modes

Per the “SAR Measurement Procedures for 3G Devices” released in October, 2007, 12.2 kbps RMC, 12.2 kbps AMR, HS-DPCCH Sub-test 1-4, and E-DCH Sub-test 1-5 modes were considered. The conducted power measurements (per section 5.2 of 3GPP TS 34.121) for each mode are shown in the table below.

Band	Channel	Conducted power (dBm) for WCDMA modes		Conducted Power (dBm) for WCDMA – HSDPA (Rel 5) Modes				Conducted Power (dBm) for WCDMA – HSPA (HSUPA/HSDPA-Rel 6) Modes				
		RMC	AMR	Subtest 1	Subtest 2	Subtest 3	Subtest 4	Subtest 1	Subtest 2	Subtest 3	Subtest 4	Subtest 5
WCDMA 850	4132	23.90	23.86	23.87	23.92	23.86	23.97	23.92	23.92	23.90	23.93	23.86
	4180	24.04	24.01	24.03	24.09	24.01	24.03	23.99	24.04	24.01	24.07	24.05
	4233	23.98	23.86	23.99	23.88	23.92	23.80	23.96	23.90	23.96	23.94	23.94
WCDMA 1900	9262	24.09	24.04	24.12	24.04	24.06	24.05	24.05	24.10	24.06	24.02	24.08
	9400	24.10	24.02	24.01	24.11	24.07	24.10	24.05	24.07	24.03	24.08	24.06
	9538	24.05	24.09	24.13	24.18	24.13	24.15	24.17	24.13	24.12	24.16	24.12

Maximum Power Reduction (MPR)

According to 3GPP 25.101 sub-clause 6.2.2, the maximum output power is allowed to be reduced by following the table.

Table 6.1A: UE maximum output power with HS-DPCCH and E-DCH

UE transmit channel configuration	CM (dB)	MPR (dB)
For all combinations of; DPDCH, DPCCH, HS-DPCCH, E-DPDCH and E-DPCCH	$0 \leq CM \leq 3.5$	MAX (CM-1, 0)
Note 1: CM = 1 for $\beta_c/\beta_d = 12/15$, $\beta_{hs}/\beta_c = 24/15$. For all other combinations of DPDCH, DPCCH, HS-DPCCH, E-DPDCH and E-DPCCH the MPR is based on the relative CM difference.		

The device supports MPR to solve linearity issues (ACLR or SEM) due to the higher peak-to-average ratios (PAR) of the HSUPA signal. This prevents saturating the full range of the TX DAC inside of device and provides a reduced power output to the RF transceiver chip according to the Cubic Metric (a function of the combinations of DPDCH, DPCCH, HS-DPCCH, E-DPDCH and E-DPCCH).

When E-DPDCH channels are present, the beta gains on those channels are reduced first to try to get the power under the allowed limit. If the beta gains are lowered as far as possible, then a hard limiting is applied at the maximum allowed level.

The SW currently recalculates the cubic metric every time the beta gains on the E-DPDCH are reduced. The cubic metric will likely get lower each time this is done. However, there is no reported reduction of maximum output power in the HSUPA mode since the device also provides a mechanism to compensate for the power back-off by increasing the gain of TX_AGC in the transceiver (PA) device.

The end effect is that the DUT output power is identical to the case where there is no MPR in the device.

2.3.3 Wi-Fi 802.11 modes

Per “SAR Measurement Procedures for 802.11 a/b/g Transmitters” (FCC KDB pub. 248227), power measurements were performed for 802.11 operational modes. The conducted power measurements for each mode are shown in the table below. SAR testing for 802.11 modes was performed with the transmitter mode and data rate set to the configurations highlighted in bold below. The head and body positions that resulted in the highest SAR values were further tested on the additional channels and higher data rates **highlighted in blue** in the tables below.

Band	Channel	Conducted Power (dBm) for 802.11b Mode Data Rates			
		1 Mbps	2 Mbps	5.5 Mbps	11 Mbps
Wi-Fi 2450 MHz	1	17.73	17.88	18.91	19.01
	6	17.97	18.13	19.12	19.17
	11	17.83	17.86	19.04	18.89

Band	Channel	Conducted Power (dBm) for 802.11g Mode Data Rates							
		6 Mbps	9 Mbps	12 Mbps	18 Mbps	24 Mbps	36 Mbps	48 Mbps	54 Mbps
Wi-Fi 2450 MHz	1	17.68	17.65	17.18	17.2	15.73	15.69	14.38	14.34
	6	17.91	17.84	17.43	17.42	15.93	15.87	14.55	14.55
	11	17.63	17.71	17.27	17.37	15.82	15.85	14.38	14.75

Band	Channel	Conducted Power (dBm) for 802.11n Mode Data Rates (20 MHz Channel, 800 ns Guard Interval)							
		6.5 Mbps	13 Mbps	19.5 Mbps	26 Mbps	39 Mbps	52 Mbps	58.5 Mbps	65 Mbps
Wi-Fi 2450 MHz	1	17.59	17.23	17.22	15.65	15.64	14.17	14.1	13.24
	6	17.83	17.43	17.46	15.74	15.87	14.18	14.29	13.45
	11	17.68	17.16	17.36	15.74	15.75	14.14	14.15	13.23

Band	Channel	Conducted Power (dBm) for 802.11n Mode Data Rates (20 MHz Channel, 400 ns Guard Interval)							
		7.2 Mbps	14.4 Mbps	21.6 Mbps	28.8 Mbps	43.3 Mbps	57.7 Mbps	65 Mbps	72.2 Mbps
Wi-Fi 2450 MHz	1	17.53	17.1	17.13	15.56	15.71	14.17	14.15	13.32
	6	17.74	17.34	17.34	15.87	15.85	14.51	14.39	13.53
	11	17.59	17.09	17.17	15.54	15.69	15.2	14.18	13.37

2.3.4 Power limit reduction schemes

The DUT utilizes a set of reduced limits for the maximum transmit when the mobile hotspot functionality is enabled. Tables of the reduced limits used for testing are given below. A complete description of this functionality is provided in the “Operational Description” contained within Exhibit 12A. The implementation to trigger the reduction in power requires the device to be radiating, which prevents conducted power measurements of this functionality without modification to the unit. The power reductions levels are verified by means of the SAR measurements provided in the Supplemental SAR report.

Mode(s) of Operation	WCDMA 1900
Channels	9262 - 9538
Duty Cycle	1:1
Maximum Output Power Setting (dBm)	24.0
Time Avg Output Power Setting (dBm)	24.0
Reduced Maximum Output Power Setting (dBm)	
Reduced Maximum Output Power Setting (dBm)	23.2
Time Avg Output Power Setting (dBm)	23.2

3. Test Equipment Used

3.1 Dosimetric System

The Motorola Mobile Devices Business ADR Test Services Laboratory utilizes a Dosimetric Assessment System (Dasy4™ v4.7) manufactured by Schmid & Partner Engineering AG (SPEAG™), of Zurich Switzerland. All the SAR measurements are taken within a shielded enclosure. The overall 10g RSS uncertainty of the measurement system is $\pm 10.8\%$ (K=1) with an expanded uncertainty of $\pm 21.6\%$ (K=2). The overall 1g RSS uncertainty of the measurement system is $\pm 11.1\%$ (K=1) with an expanded uncertainty of $\pm 22.2\%$ (K=2). The measurement uncertainty budget is given in Appendix 7. Per IEEE 1528, this uncertainty budget is applicable to the SAR range of 0.4W/kg to 10W/kg.

The list of calibrated equipment used for the measurements is shown in the following table.

Description	Serial Number	Cal Due Date
DASY4™ DAE V1	SN 702	14-Apr-2012
E-Field Probe ES3DV3	SN 3037	13-Apr-2012
DASY4™ DAE V1	SN 434	13-Jan-2012
E-Field Probe ES3DV3	SN 3115	12-Jan-2012
DASY4™ DAE V1	SN 699	20-Sep-2011
E-Field Probe ES3DV3	SN 3184	11-Mar-2012
S.A.M. Phantom used for 800 MHz	TP-1235	
S.A.M. Phantom used for 2450 MHz	TP-1318	
S.A.M. Phantom used for 1900 MHz	TP-1136	
Dipole Validation Kit, DV835V2	436tr	18-Mar-2013
Dipole Validation Kit, DV1800V2	271tr	8-Mar-2012
Dipole Validation Kit, DV2450V2	766	15-Jul-2013

3.2 Additional Equipment

Description	Serial Number	Cal Date	Cal Due Date
Signal Generator HP8648C	3847A04982	Nov-18-2009	Nov-18-2011
Power Meter E4419B	GB39510900	Mar-28-2011	Mar-28-2013
Power Sensor #1 - E9301A	US39211007	Aug-16-2011	Aug-16-2012
Power Sensor #2 - E9301A	US39211008	Aug-16-2011	Aug-16-2012
Signal Generator HP8648C	3847A04632	Aug-13-2011	Aug-13-2013
Power Meter E4419B	GB39511087	Dec-22-2009	Dec-22-2011
Power Sensor #1 - E9301A	US39211006	Oct-25-2010	Oct-25-2011
Power Sensor #2 - E9301A	US39210934	Oct-25-2010	Oct-25-2011
Signal Generator HP8648C	3847A04843	Mar-28-2011	Mar-28-2013
Power Meter E4419B	GB39511084	Mar-28-2011	Mar-28-2013
Power Sensor #1 - E9301A	US39210929	Mar-31-2011	Mar-31-2012
Power Sensor #2 - E9301A	US39210930	Mar-31-2011	Mar-31-2012
Network Analyzer HP8753ES	US39171846	May-19-2011	May-19-2012
Dielectric Probe Kit HP85070C	US99360070		

4. Electrical parameters of the tissue simulating liquid

Prior to conducting SAR measurements, the relative permittivity, ϵ_r , and the conductivity, σ , of the tissue simulating liquids were measured with a HP85070 Dielectric Probe Kit. These values, along with the temperature of the simulated tissue are shown in the table below. The recommended limits for permittivity and conductivity are also shown. A mass density of $\rho=1\text{g/cm}^3$ was entered into the system in all the cases. It can be seen that the measured parameters are within tolerance of the recommended limits specified in [1] and [5].

E-field probes calibrated at 1810 MHz were used for "1900 MHz" band (1850 MHz - 1910 MHz) SAR measurements. FCC KDB pub. 450824 provides additional requirements on page 3 of 6 for SAR testing that is performed with probe calibration points that are more than 50 MHz removed from the measured bands. The KDB requires; "(2) When nominal tissue dielectric parameters are specified in the probe calibration data, the tissue dielectric parameters measured for routine measurements should be less than the target ϵ_r and higher than the target σ values to minimize SAR underestimations". The 1900 MHz simulated tissues listed below meet these criteria.

f (MHz)	Tissue type	Limits / Measured	Dielectric Parameters		
			ϵ_r	σ (S/m)	Temp (°C)
835	Head	Measured, 10/12/2011	41.9	0.92	19.6
		Recommended Limits	39.4 - 43.6	0.86 - 0.95	18-25
	Body	Measured, 10/11/2011	55.1	0.98	19.3
		Measured, 10/13/2011	54.6	0.97	19.2
		Measured, 10/18/2011	54.4	0.98	19.9
		Recommended Limits	52.4 - 58.0	0.92 - 1.02	18-25
1880	Head	Measured, 10/11/2011	38.3	1.46	19.5
		Measured, 10/12/2011	38.8	1.47	19.8
		Recommended Limits	38.0 - 40.0	1.40 - 1.47	18-25
	Body	Measured, 10/7/2011	51.0	1.57	19.9
		Measured, 10/11/2011	50.9	1.58	19.6
		Measured, 10/12/2011	50.7	1.59	19.8
		Measured, 10/14/2011	50.8	1.59	19.9
		Recommended Limits	50.6 - 53.3	1.52 - 1.60	18-25
2450	Head	Measured, 7/26/2011	36.3	1.85	19.5
		Measured, 7/27/2011	36.3	1.85	19.7
		Recommended Limits	35.3 - 43.1	1.71 - 1.89	18-25
	Body	Measured, 7/27/2011	47.9	2.03	19.5
		Recommended Limits	47.4 - 58.0	1.85 - 2.05	18-25

The list of ingredients and the percent composition used for the tissue simulates are indicated in the table below.

Ingredient	835MHz / 900 MHz	835MHz / 900 MHz	1800MHz / 1900 MHz	1800 MHz / 1900 MHz	2450MHz	2450 MHz
	Head	Body	Head	Body	Head	Body
Sugar	57	44.9	--	--	--	--
DGBE	--	--	47	30.8	--	30
Diacetin	--	--	--	--	51	--
Water	40.45	53.06	52.62	68.8	48.75	70
Salt	1.45	0.94	0.38	0.4	0.15	--
HEC	1	1	--	--	--	--
Bact.	0.1	0.1	--	--	0.1	--

5. System Accuracy Verification

A system accuracy verification of the DASY4™ was performed using the measurement equipment listed in Section 3.1. The daily system accuracy verification occurs within the flat section of the SAM phantom.

A SAR measurement was performed to verify the measured SAR was within ±10% from the target SAR indicated in Appendix 8. These frequencies are within ±10% of the compliance test mid-band frequency as required in [1] and [5]. The test was conducted on the same days as the measurement of the DUT. Recommended limits for permittivity and conductivity, specified in [5], are shown in the table below. The obtained results from the system accuracy verification are also displayed in the table below. SAR values are normalized to 1W forward power delivered to the dipole. It is seen that the system is operating within its specification, as the results are within acceptable tolerance of the reference values. The distributions of SAR compare well with those of the reference measurements (see Appendix 1). The tissue stimulant depth was verified to be 15.0cm ±0.5cm. Z-axis scans showing the SAR penetration are also included in Appendix 1.

System Accuracy Verification Measurements for Head SAR Measurements							
f (MHz)	Description	Measured SAR (W/kg), 1 gram	Normalized SAR (W/kg), 1 gram	Dielectric Parameters		Ambient Temp (°C)	Tissue Temp (°C)
				ε _r	σ (S/m)		
835	Measured, 10/12/2011	2.01	10.05	41.9	0.92	20.8	20.5
	Recommended Limits	2.42	9.73	41.5 ±5%	0.90 ±5%	18-25	18-25
1800	Measured, 10/11/2011	7.98	39.9	38.6	1.37	21.1	20.5
	Measured, 10/12/2011	7.72	38.6	38.5	1.38	21.2	20.2
	Recommended Limits	9.41	38.5	40.0 ±5%	1.40 ±5%	18-25	18-25
2450	Measured, 7/26/2011	11.2	57.5	36.3	1.85	21.1	20.2
	Recommended Limits	13.9	54.8±10%	39.2 ±5%	1.80 ±5%	18-25	18-25

System Accuracy Verification Measurements for Body SAR Measurements							
f (MHz)	Description	Measured SAR (W/kg), 1 gram	Normalized SAR (W/kg), 1 gram	Dielectric Parameters		Ambient Temp (°C)	Tissue Temp (°C)
				ε _r	σ (S/m)		
835	Measured, 10/11/2011	1.98	9.9	55.1	0.98	20.9	20.5
	Measured, 10/13/2011	1.93	9.65	54.6	0.97	21.3	20.7
	Measured, 10/18/2011	1.94	9.7	54.4	0.98	21.6	20.2
	Recommended Limits	2.56	10.2	55.2 ±5%	0.97 ±5%	18-25	18-25
1800	Measured, 10/7/2011	7.77	38.85	51.3	1.47	21.5	20.5
	Measured, 10/11/2011	7.87	39.35	51.2	1.48	21.0	20.5
	Measured, 10/12/2011	7.95	39.75	51.1	1.49	21.3	20.7
	Measured, 10/14/2011	8.0	40.0	51.1	1.49	21.4	20.5
	Recommended Limits	9.25	37.9	53.3 ±5%	1.52 ±5%	18-25	18-25
2450	Measured, 7/27/2011	11.50	52.5	47.9	2.03	21.0	20.4
	Recommended Limits	12.8	50.4±10%	52.7 ±5%	1.95 ±5%	18-25	18-25

The following probe conversion factors were used on the E-Field probe(s) used for the system accuracy verification measurements:

Description	Serial Number	f (MHz)	Conversion Factor	Cal Cert pg #
E-Field Probe ES3DV3	SN 3184	835 – Head	6.11	5 of 11
		835 – Body	6.1	6 of 11
		1810 – Head	5.11	5 of 11
		1810 - Body	4.9	6 of 11
	SN 3037	2450 – Body	4.24	6 of 11
	SN 3115	2450 – Head	4.39	5 of 11

6. Test Results

For GSM and WCDMA modes, the test sample was operated using an actual transmission through a base station simulator. Wi-Fi testing was conducted using manufacturer test mode software, per guidance given in FCC KDB 248227. The base station simulator or test software was set up for the proper channels, transmitter power levels and transmit modes of operation.

The phone was tested in the configurations stipulated in [1], [4] and [5]. The phone was positioned into these configurations using the device holder supplied with the DASY4™ SAR measurement system. The default settings for the “coarse” and “cube” scans were chosen and used for measurements. The grid spacing of the coarse scan was set to 15 mm or less as shown in the SAR plots included in Appendices 2 through 5. Please refer to the DASY4™ manual for additional information on SAR scanning procedures and algorithms used.

The DUT covered by this report has the following battery options:

SNN5891A - 1600 mAh Battery

This battery was used to do all of the SAR testing. The phone was placed in the SAR measurement system with a fully charged battery.

6.1 Head Adjacent Test Results

The SAR results shown in tables 1 through 4 are maximum SAR values averaged over 1 gram of phantom tissue, to demonstrate compliance to [3] and also over 10 grams of phantom tissue, to demonstrate compliance to [6]. Also shown are the temperature of the simulated tissue after the test, the measured drift, the measured conducted output power levels, power reduction amount (when applicable), the measured SAR corrected for probe calibration (when applicable), and the extrapolated SAR. The exact method of extrapolation is:

$$\text{Extrapolated SAR} = (\text{Measured or Corrected SAR}) * 10^{(-\text{drift}/10)}$$

The SAR reported at the end of the measurement process by the DASY4™ measurement system can be scaled up by the measured drift to determine the SAR at the beginning of the measurement process. This is the most conservative SAR because it corresponds to the average output power at the beginning of the SAR test. This extrapolation has been done because when the DUT is operating properly it may exhibit a slump in radiated power and SAR over time. This is verified by measuring the SAR drift after the test.

The left head and right head SAR contour distributions are similar. Because of this similarity, the cheek/touch and 15° tilt test conditions with the highest SAR values in each band are indicated as bold numbers in the following tables and are included in Appendix 2. All other test conditions measured lower SAR values than those included in Appendix 2.

The SAR measurements were performed using the SAM phantoms listed in section 3.1. Since the same phantoms and simulated tissue were used for the system accuracy verification and the device SAR measurements, the Z-axis scans included in Appendix 1 are applicable for verification of simulated tissue depth to be 15.0cm ±0.5cm.

The following probe conversion factors were used on the E-Field probe(s) used for the head adjacent measurements:

Description	Serial Number	f (MHz)	Conversion Factor	Cal Cert pg #
E-Field Probe ES3DV3	SN 3184	835	6.11	5 of 11
		1810	5.11	5 of 11
	SN 3115	2450	4.39	5 of 11

Left Head Cheek Position															
f (MHz)	Mode	Battery/Accessory	Channel	Temp (°C)	Drift (dB)	DUT Power		10 g SAR value			1 g SAR value			Test Plot	
						Measured (dBm)	Power Reduction (dB)	Measured (W/kg)	Corrected (W/kg)	Extrapolated (W/kg)	Measured (W/kg)	Corrected (W/kg)	Extrapolated (W/kg)	Grid	Plot Page
835	GSM 850, CS Voice	SNN5899A	128												
			190	20.0	-0.167	32.99		0.224		0.23	0.308		0.32		
			251												
	WCDMA 850, 12.2 kbps RMC		4132												
			4180	20.0	-0.0242	24.04		0.231		0.23	0.309		0.31		
1880	GSM 1900, CS Voice	4233													
		512													
	661	20.2	-0.104	30.11		0.276		0.28	0.459		0.47	5x5x7	54		
	810														
	GPRS 1900, PS Data 4 Uplots	661	20.1	0.0891	24.46		0.275		0.28	0.452		0.45			
WCDMA 1900, 12.2 kbps RMC	9262	20.0	-0.114	24.09		0.519		0.53	0.853		0.88				
	9400	20.0	-0.0388	24.10		0.535		0.54	0.892		0.90	5x5x7	55		
	9538	20.0	-0.173	24.05		0.486		0.51	0.816		0.85				
	1	19.2	0.0336	17.73		0.218		0.22	0.491		0.49				
2450	802.11b, 1 Mbps	6	19.9	0.234	17.97		0.210		0.21	0.476		0.48			
		11	19.2	-0.0819	17.83		0.205		0.21	0.466		0.47			
		1	19.2	-0.101	18.91		0.204		0.21	0.457		0.47			
	802.11b, 5.5 Mbps	6	19.2	-0.158	19.12		0.203		0.21	0.457		0.47			
		11	19.2	0.121	19.04		0.196		0.20	0.445		0.45			
		1	19.2	-0.120	19.01		0.201		0.21	0.450		0.46			
	802.11b, 11 Mbps	6	19.2	-0.178	19.17		0.228		0.24	0.524		0.55	5x5x7	56	
		11	19.2	0.0548	18.89		0.194		0.19	0.439		0.44			

Table 1: SAR measurement results at the highest possible output power, measured in a head cheek position against the ICNIRP and ANSI SAR Limit.

Right Head Cheek Position															
f (MHz)	Mode	Battery/Accessory	Channel	Temp (°C)	Drift (dB)	DUT Power		10 g SAR value			1 g SAR value			Test Plot	
						Measured (dBm)	Power Reduction (dB)	Measured (W/kg)	Corrected (W/kg)	Extrapolated (W/kg)	Measured (W/kg)	Corrected (W/kg)	Extrapolated (W/kg)	Grid	Plot Page
835	GSM 850, CS Voice	SNN5899A	128												
			190	20.0	-0.0304	32.99		0.279		0.28	0.37		0.37	5x5x7	57
			251												
	GPRS 850, PS Data 4 Uplots		190	20.3	-0.487	27.65		0.258		0.29	0.342		0.38		
			4132												
WCDMA 850, 12.2 kbps RMC	4180	20.0	-0.0252	24.04		0.281		0.28	0.37		0.37	5x5x7	58		
	4233														
	GSM 1900, CS Voice	512													
		661	20.3	0.0932	30.11		0.275		0.28	0.463		0.46			
WCDMA 1900, 12.2 kbps RMC	810														
	9262														
	9400	20.1	0.0078	24.10		0.471		0.47	0.778		0.78				
2450	802.11b, 1 Mbps	9538													
		1													
		6	19.9	-0.054	17.97		0.13		0.13	0.273		0.28			
11															

Table 2: SAR measurement results at the highest possible output power, measured in a head cheek position against the ICNIRP and ANSI SAR Limit.

Left Head 15° Tilt Position															
f (MHz)	Mode	Battery/Accessory	Channel	Temp (°C)	Drift (dB)	DUT Power		10 g SAR value			1 g SAR value			Test Plot	
						Measured (dBm)	Power Reduction (dB)	Measured (W/kg)	Corrected (W/kg)	Extrapolated (W/kg)	Measured (W/kg)	Corrected (W/kg)	Extrapolated (W/kg)	Grid	Plot Page
835	GSM 850, CS Voice	SNN5899A	128												
			190	20.0	-0.0185	32.99		0.161		0.16	0.21		0.21		
			251												
	4132														
	4180		20.0	0.0981	24.04		0.174		0.17	0.229		0.23			
1880	GSM 1900, CS Voice		4233												
			512												
			661	20.0	-0.22	30.11		0.104		0.11	0.176		0.19	5x5x7	59
	810														
	9262														
2450	802.11b, 1 Mbps		9400	20.1	-0.0248	24.10		0.281		0.29	0.37		0.37	5x5x7	60
			9538												
			1												
				6	19.2	0.080	17.97		0.0362		0.04	0.0695		0.07	
				11											

Table 3: SAR measurement results at the highest possible output power, measured in a head tilt position against the ICNIRP and ANSI SAR Limit.

Right Head 15° Tilt Position															
f (MHz)	Mode	Battery/Accessory	Channel	Temp (°C)	Drift (dB)	DUT Power		10 g SAR value			1 g SAR value			Test Plot	
						Measured (dBm)	Power Reduction (dB)	Measured (W/kg)	Corrected (W/kg)	Extrapolated (W/kg)	Measured (W/kg)	Corrected (W/kg)	Extrapolated (W/kg)	Grid	Plot Page
835	GSM 850, CS Voice	SNN5899A	128												
			190	20.0	-0.101	32.99		0.177		0.18	0.232		0.24	5x5x7	61
			251												
	4132														
	4180		20.0	-0.25	24.04		0.81		0.29	0.370		0.38	5x5x7	62	
1880	GSM 1900, CS Voice		4233												
			512												
			661	20.2	0.367	30.11		0.104		0.10	0.174		0.17		
	810														
	9262														
2450	802.11b, 1 Mbps		9400	20.2	0.109	24.10		0.201		0.20	0.345		0.35		
			9538												
			1												
				6	19.2	0.031	17.97		0.0349		0.03	0.0826		0.08	5x5x7
				11											

Table 4: SAR measurement results at the highest possible output power, measured in a head tilt position against the ICNIRP and ANSI SAR Limit.

6.2 Body Worn Test Results

The SAR results shown in tables 5 through 7 are maximum SAR values averaged over 1 gram of phantom tissue, to demonstrate compliance to [3] and also over 10 grams of phantom tissue, to demonstrate compliance to [6]. Also shown are the temperature of the simulated tissue after the test, the measured drift, the measured conducted output power levels, power reduction amount (when applicable), the measured SAR corrected for probe calibration (when applicable), and the extrapolated SAR. The exact method of extrapolation is:

$$\text{Extrapolated SAR} = (\text{Measured or Corrected SAR}) * 10^{(-\text{drift}/10)}$$

The SAR reported at the end of the measurement process by the DASY4™ measurement system can be scaled up by the measured drift to determine the SAR at the beginning of the measurement process. This is the most conservative SAR because it corresponds to the average output power at the beginning of the SAR test. This extrapolation has been done because when the DUT is operating properly it may exhibit a slump in radiated power and SAR over time. This is verified by measuring the SAR drift after the test.

The test conditions that produced the highest SAR values in each band are indicated as bold numbers in the following tables and are included in Appendix 3. All other test conditions measured lower SAR values than those included in Appendix 3.

A “flat” phantom was for the body-worn tests. This “flat” phantom is made out of 1” thick natural High Density Polyethylene with a thickness at the bottom equal to 2.0mm. It measures 52.7cm(long) x 26.7cm(wide) x 21.2cm(tall).

The tissue stimulant depth was verified to be 15.0cm ±0.5cm. The same device holder described in section 6 was used for positioning the phone. The functional accessories were divided into two categories, the ones with metal components and the ones with non-metal components. For non-metallic component accessories’, testing was performed on the accessory that displayed the closest proximity to the flat phantom. Each metallic component accessory, if any, was checked for uniqueness of metal component so that each is tested with the device. If multiple accessories shared an identical metal component, only the accessory that dictates the closest spacing to the body was tested. The cellular phone was tested with a headset connected to the device for all body-worn SAR measurements.

There are no body-worn accessories available for this phone at the time of testing thus the device was tested per the Supplement C testing guidelines for devices that do not have body-worn accessories. A separation distance of 25 mm between the device and the flat phantom was used for testing body-worn SAR. The chosen separation distance of 25 mm is utilized in order to support any case or holder accessories offered or to be offered by Motorola for this product. The device was tested with the front and back of the device facing the phantom. Both sides of the device were tested for Body SAR for the purpose of including the SAR evaluation for body-worn accessories that support the device with the front side facing the user.

The cellular phone was also tested in data mode operations. For these tests, a separation distance of 25 mm between the device and the flat phantom was used. The device was tested in the worst-case SAR position and channel configuration from the voice-mode body-worn testing for the data modes.

The following probe conversion factors were used on the E-Field probe(s) used for the body worn measurements:

Description	Serial Number	f (MHz)	Conversion Factor	Cal Cert pg #
E-Field Probe ES3DV3	SN 3184	835	6.1	6 of 11
		1810	4.9	6 of 11
	SN 3037	2450	4.24	6 of 11

Body-Worn, Front of Phone 15 mm from Phantom																
f (MHz)	Mode	Battery/Accessory	Channel	Temp (°C)	Drift (dB)	DUT Power		10 g SAR value			1 g SAR value			Test Plot		
						Measured (dBm)	Power Reduction (dB)	Measured (W/kg)	Corrected (W/kg)	Extrapolated (W/kg)	Measured (W/kg)	Corrected (W/kg)	Extrapolated (W/kg)	Grid	Plot Page	
835	GSM 850, CS Voice	SNN5899A	128													
			190	19.7	-0.118	32.99			0.182		0.19	0.246		0.25		
			251													
	WCDMA 850, 12.2 kbps RMC		4132													
			4180	20.0	0.0056	24.04			0.178		0.18	0.238		0.24		
1880	GSM 1900, CS Voice		512													
			661	20.5	0.122	30.11			0.198		0.20	0.316		0.32		
			810													
	WCDMA 1900, 12.2 kbps RMC		9262													
			9400	20.3	-0.0327	24.10			0.374		0.38	0.596		0.60		
2450	802.11b, 1 Mbps		9538													
			1													
			6	20.0	-0.016	17.97			0.0226		0.02	0.0396		0.04		
				11												

Table 5: SAR measurement results at the highest possible output power, measured in a body-worn position against the ICNIRP and ANSI SAR Limit.

Body-Worn, Back of Phone 15 mm from Phantom																
f (MHz)	Mode	Battery/Accessory	Channel	Temp (°C)	Drift (dB)	DUT Power		10 g SAR value			1 g SAR value			Test Plot		
						Measured (dBm)	Power Reduction (dB)	Measured (W/kg)	Corrected (W/kg)	Extrapolated (W/kg)	Measured (W/kg)	Corrected (W/kg)	Extrapolated (W/kg)	Grid	Plot Page	
835	GSM 850, CS Voice	SNN5899A	128													
			190	20.2	-0.175	32.99			0.377		0.39	0.522		0.54	5x5x7	65
			251													
	WCDMA 850, 12.2 kbps RMC		4132													
			4180	20.0	-0.225	24.04			0.518		0.55	0.716		0.75	5x5x7	66
1880	GSM 1900, CS Voice		4233													
			512													
			661	20.3	-0.0246	30.11			0.235		0.24	0.39		0.39	5x5x7	67
	WCDMA 1900, 12.2 kbps RMC		810													
			9262													
2450	802.11b, 1 Mbps		9400	20.2	-0.0968	24.10			0.45		0.46	0.739		0.76	5x5x7	68
			9538													
			1	19.2	-0.0639	17.73			0.111		0.11	0.218		0.22	5x5x7	69
	802.11b, 5.5 Mbps		6	20.0	-0.0371	17.97			0.0892		0.09	0.178		0.18		
			11	19.2	0.0113	17.83			0.108		0.11	0.215		0.22		
		1	19.2	0.0971	18.91			0.108		0.11	0.212		0.21			
		6	19.2	0.0351	19.12			0.107		0.11	0.211		0.21			
		11	19.2	-0.0368	19.04			0.0964		0.10	0.192		0.19			
		802.11b, 11 Mbps	1	19.2	0.0259	19.01			0.11		0.11	0.217		0.22		
			6	19.2	0.0124	19.17			0.108		0.11	0.214		0.21		
			11	19.2	0.0425	18.89			0.0995		0.10	0.198		0.20		

Table 6: SAR measurement results at the highest possible output power, measured in a body-worn position against the ICNIRP and ANSI SAR Limit.

Body-Worn, Back of Phone 25 mm from Phantom																
f (MHz)	Mode	Battery/Accessory	Channel	Temp (°C)	Drift (dB)	DUT Power		10 g SAR value			1 g SAR value			Test Plot		
						Measured (dBm)	Power Reduction (dB)	Measured (W/kg)	Corrected (W/kg)	Extrapolated (W/kg)	Measured (W/kg)	Corrected (W/kg)	Extrapolated (W/kg)	Grid	Plot Page	
835	GPRS 850, PS Data 4 Uplots	SNN5899A	128													
			190	20.0	-0.0277	32.99		0.217		0.22	0.291		0.29			
			251													
	EDGE 850, PS Data 4 Uplots		128													
			190	20.0	-0.133	24.04		0.0763		0.08	0.103		0.11			
			251													
1880	GPRS 190, PS Data 4 Uplots	512														
		661	20.0	0.254	30.11		0.0827		0.08	0.127		0.13				
		810														
	EDGE 190, PS Data 4 Uplots	512														
		661	20.0	-0.331	24.10		0.0553		0.06	0.0855		0.09				
		810														

Table 7: SAR measurement results at the highest possible output power, measured in a body-worn position against the ICNIRP and ANSI SAR Limit.

6.3 Mobile Hotspot Test Results

The DUT is capable of functioning as a Wi-Fi to Cellular mobile hotspot. Additional SAR testing was performed according to the test guidelines provided per FCC KDB 941225 D06. Testing was performed with a separation of 1 cm between the DUT and the “flat” phantom. The DUT was positioned for SAR tests with the front and back surfaces facing the phantom, and also with the edges facing the phantom in which the transmitting antenna is less than 2.5 cm from the edge.

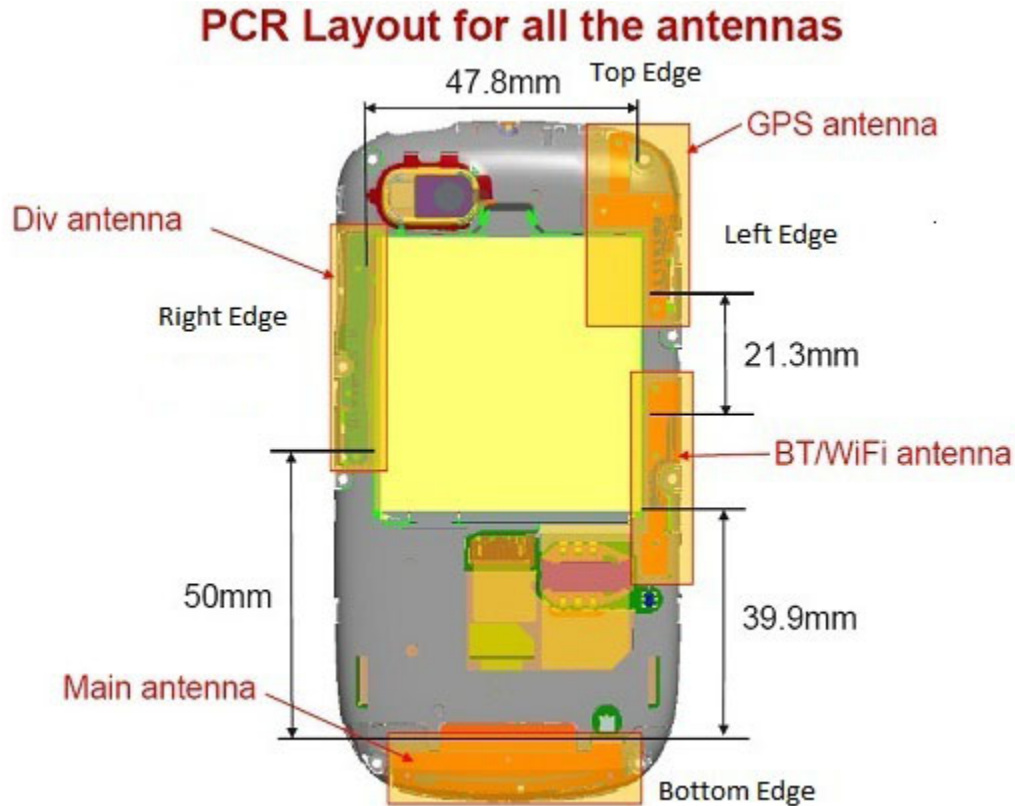

Mobile Hotspot Edges/Surfaces for SAR testing						
Mode	Top	Bottom	Left	Right	Front	Back
GSM/WCDMA	NO	YES	YES	YES	YES	YES
Wi-Fi	NO	NO	YES	NO	YES	YES

The SAR results shown in tables 8 through 12 are maximum SAR values averaged over 1 gram of phantom tissue, to demonstrate compliance to [3] and also over 10 grams of phantom tissue, to demonstrate compliance to [6]. Also shown are the temperature of the simulated tissue after the test, the measured drift, the measured conducted output power levels, power reduction amount (when applicable), the measured SAR corrected for probe calibration (when applicable), and the extrapolated SAR. The exact method of extrapolation is:

$$Extrapolated\ SAR = (Measured\ or\ Corrected\ SAR) * 10^{(-drift/10)}$$

The SAR reported at the end of the measurement process by the DASY4™ measurement system can be scaled up by the measured drift to determine the SAR at the beginning of the measurement process. This is the most conservative SAR because it corresponds to the average output power at the beginning of the SAR test. This

extrapolation has been done because when the DUT is operating properly it may exhibit a slump in radiated power and SAR over time. This is verified by measuring the SAR drift after the test.

The DUT utilizes a reduced limit for the maximum transmit power when the mobile hotspot functionality is enabled, as described above in 2.2.2. A complete description of this functionality is provided in the “Operational Description” contained within Exhibit 12.

The test conditions that produced the highest SAR values in each band are indicated as bold numbers in the following tables and are included in Appendix 5. All other test conditions measured lower SAR values than those included in Appendix 5.

The simulated tissue depth was verified to be 15.0 cm ± 0.5 cm. The same device holder described in section 6 was used for positioning the phone.

The following probe conversion factors were used on the E-Field probe(s) used for the Mobile Hotspot Mode measurements:

Description	Serial Number	f (MHz)	Conversion Factor	Cal Cert pg #
E-Field Probe ES3DV3	SN 3184	835	6.1	6 of 11
		1810	4.9	6 of 11
	SN 3037	2450	4.24	6 of 11

Mobile Hotspot Mode; Front Surface of Phone 10mm from Phantom																	
f (MHz)	Mode	Battery/Accessory	Channel	Temp (°C)	Drift (dB)	DUT Power		10 g SAR value			1 g SAR value			Test Plot			
						Measured (dBm)	Power Reduction (dB)	Measured (W/kg)	Corrected (W/kg)	Extrapolated (W/kg)	Measured (W/kg)	Corrected (W/kg)	Extrapolated (W/kg)	Grid	Plot Page		
835	GPRS 850, PS Data 3 Uplots	SNN5899A	128														
			190	20.7	0.729	32.99			0.414		0.41	0.556		0.56			
			251														
	WCDMA 850, 12.2 kbps RMC		4132														
			4180	19.9	0.0366	24.04			0.223		0.22	0.302		0.30			
1880	GPRS 1900, PS Data 3 Uplots	512															
		661	20.7	-0.395	30.11			0.283		0.31	0.448		0.49				
		810															
	WCDMA 1900, 12.2 kbps RMC	9262	20.0	-0.0132	24.09	0.8	0.610		0.61	0.996		1.00					
		9400	20.0	0.14	24.10	0.8	0.664		0.66	1.08		1.08					
2450	802.11b, 1 Mbps	9538	20.0	0.185	24.05	0.8	0.683		0.68	1.11		1.11					
		1															
		6	19.2	-0.183	17.97			0.0589	0.11	0.06	0.106		0.11				
			11														

Table 8: SAR measurement results at the highest possible output power, measured against the ICNIRP and ANSI SAR Limit.

Mobile Hotspot, Back Surface of Phone 10 mm from Phantom																
f (MHz)	Mode	Battery/Accessory	Channel	Temp (°C)	Drift (dB)	DUT Power		10 g SAR value			1 g SAR value			Test Plot		
						Measured (dBm)	Power Reduction (dB)	Measured (W/kg)	Corrected (W/kg)	Extrapolated (W/kg)	Measured (W/kg)	Corrected (W/kg)	Extrapolated (W/kg)	Grid	Plot Page	
835	GPRS 850, PS Data 4 Uplots	SNN5899A	128	20.5	-0.155	33.18		0.75		0.78	1.02		1.06	5x5x7	71	
			190	20.7	-0.954	32.99		0.657		0.82	0.919		1.14			
			251	20.5	-0.12	32.75		0.559		0.57	0.774		0.80			
	WCDMA 850, 12.2 kbps RMC		4132													
			4180	20.0	0.0303	24.04		0.408		0.41	0.674		0.67	5x5x7	72	
			4233													
1880	GPRS 1900, PS Data 4 Uplots	512														
		661	20.2	-0.0393	30.11		0.326		0.33	0.541		0.55				
		810														
	WCDMA 1900, 12.2 kbps RMC	9262	20.0	-0.0049	24.09	0.8	0.766		0.77	1.3		1.30				
		9400	20.1	-0.0452	24.10	0.8	0.708		0.72	1.2		1.21				
		9538	20.0	0.13	24.05	0.8	0.785		0.79	1.32		1.32	5x5x7	73		
2450	802.11b, 1 Mbps	1	19.2	0.158	17.73		0.204		0.20	0.44		0.44				
		6	19.2	-0.0507	17.97		0.203		0.21	0.438		0.44				
		11	19.2	0.035	17.83		0.202		0.20	0.438		0.44				
	802.11b, 5.5 Mbps	1	19.2	-0.0067	18.91		0.152		0.15	0.326		0.33				
		6	19.2	0.0090	19.12		0.206		0.21	0.445		0.45				
		11	19.2	0.117	19.04		0.203		0.20	0.442		0.44				
	802.11b, 11 Mbps	1	19.2	-0.0441	19.01		0.158		0.16	0.337		0.34				
		6	19.2	-0.0043	19.17		0.209		0.21	0.453		0.45	5x5x7	74		
		11	19.2	-0.0346	18.89		0.191		0.19	0.413		0.42				

Table 9: SAR measurement results at the highest possible output power, measured against the ICNIRP and ANSI SAR Limit.

Mobile Hotspot, Left Edge of Phone 10 mm from Phantom																
f (MHz)	Mode	Battery/Accessory	Channel	Temp (°C)	Drift (dB)	DUT Power		10 g SAR value			1 g SAR value			Test Plot		
						Measured (dBm)	Power Reduction (dB)	Measured (W/kg)	Corrected (W/kg)	Extrapolated (W/kg)	Measured (W/kg)	Corrected (W/kg)	Extrapolated (W/kg)	Grid	Plot Page	
835	GPRS 850, PS Data 3 Uplots	SNN5899A	128													
			190	20.5	-0.117	32.99		0.256		0.26	0.37		0.38			
			251													
	WCDMA 850, 12.2 kbps RMC		4132													
			4180	19.8	-0.0521	24.04		0.12		0.12	0.177		0.18			
			4233													
1880	GPRS 1900, PS Data 3 Uplots	512														
		661	19.8	-0.122	30.11		0.105		0.11	0.181		0.19				
		810														
	WCDMA 1900, 12.2 kbps RMC	9262														
		9400	20.2	0.0813	24.10	0.8	0.207		0.21	0.359		0.36				
		9538														
2450	802.11b, 1 Mbps	1														
		6	20.0	-0.0321	17.97		0.127		0.13	0.268		0.27				
		11														

Table 10: SAR measurement results at the highest possible output power, measured against the ICNIRP and ANSI SAR Limit.

Mobile Hotspot, Right Edge of Phone 10 mm from Phantom																
f (MHz)	Mode	Battery/Accessory	Channel	Temp (°C)	Drift (dB)	DUT Power		10 g SAR value			1 g SAR value			Test Plot		
						Measured (dBm)	Power Reduction (dB)	Measured (W/kg)	Corrected (W/kg)	Extrapolated (W/kg)	Measured (W/kg)	Corrected (W/kg)	Extrapolated (W/kg)	Grid	Plot Page	
835	GPRS 850, PS Data 3 Uplots	SNN5899A	128													
			190	19.8	0.467	32.99		0.281		0.28	0.397		0.40			
			251													
	WCDMA 850, 12.2 kbps RMC		4132													
			4180	20.0	-0.0254	24.04		0.264		0.27	0.375		0.38			
1880	GPRS 1900, PS Data 3 Uplots	512														
		661	19.8	-0.121	30.11		0.0843		0.09	0.14		0.14				
		810														
	WCDMA 1900, 12.2 kbps RMC	9262														
		9400	20.0	0.018	24.10	0.8	0.178		0.18	0.301		0.30				
2450	802.11b, 1 Mbps	9538														
		1														
		6	19.5	-0.0608	17.97		0.139		0.14	0.234		0.24				
			11													

Table 11: SAR measurement results at the highest possible output power, measured against the ICNIRP and ANSI SAR Limit.

Mobile Hotspot Mode; Bottom Edge of Phone 10mm from Phantom																
f (MHz)	Mode	Battery/Accessory	Channel	Temp (°C)	Drift (dB)	DUT Power		10 g SAR value			1 g SAR value			Test Plot		
						Measured (dBm)	Power Reduction (dB)	Measured (W/kg)	Corrected (W/kg)	Extrapolated (W/kg)	Measured (W/kg)	Corrected (W/kg)	Extrapolated (W/kg)	Grid	Plot Page	
835	GPRS 850, PS Data 3 Uplots	SNN5899A	128													
			190	20.0	-0.299	32.99		0.0486		0.05	0.0835		0.09			
			251													
	WCDMA 850, 12.2 kbps RMC		4132													
			4180	19.9	19.9	24.04		0.0577		0.06	0.0993		0.10			
1880	GPRS 1900, PS Data 3 Uplots	4233														
		512														
		661	19.8	0.0375	30.11		0.318		0.32	0.587		0.59	5x5x7	75		
	WCDMA 1900, 12.2 kbps RMC	810														
		9262	20.3	-0.0243	24.09	0.8	0.684		0.69	1.22		1.23				
			9400	20.3	0.0291	24.10	0.8	0.628		0.63	1.16		1.16			
			9538	20.3	-0.024	24.05	0.8	0.585		0.59	1.07		1.08			

Table 12: SAR measurement results at the highest possible output power, measured against the ICNIRP and ANSI SAR Limit.

6.4 Description and Evaluation of Simultaneous Transmitters

Per "SAR Evaluation Considerations for Handsets with Multiple Transmitters and Antennas" (FCC KDB pub. 648474), the necessity of stand-alone and simultaneous SAR testing was evaluated for the licensed and unlicensed transmitters of the device under test.

By device design the GSM and WCDMA transmitters may operate simultaneously with either the Wi-Fi 802.11 transmitter or the Bluetooth transmitter. The separation distance between the Wi-Fi 802.11/Bluetooth antenna and the main antenna is 1.76 cm. Pictorial representation of the antenna locations and separation distances are given in Exhibit 7d.

The Bluetooth transmitter of the device under test can be excluded from stand-alone and simultaneous SAR evaluation, per the **bolded** requirements from FCC KDB 648474, as follows. Note that Bluetooth mode is not intended for use in configurations against the head or during mobile hotspot operation, and this evaluation considers only the body-worn configuration.

1. The highest output conducted power measured for Bluetooth on the device under test is 8.4 mW [**≤ 12 mW**]
2. The separation distance between the Bluetooth antenna and the GSM/WCDMA antenna is 3.985 cm [**< 2.5 cm**]

The Wi-Fi and the Bluetooth cannot transmit simultaneously, so there is no co-location test requirement for Wi-Fi and Bluetooth. GSM supports voice and data transmission, though not simultaneously. WCDMA supports voice and data transmission simultaneously.

Description of Simultaneous Transmit Capabilities				
Transmitter Combinations		Scenario Supported?	Supported for Mobile Hotspot?	Notes
#1	GSM (CS Voice) + GSM (PS Data)	No	No	DUT system architecture does not support simultaneous voice and data (except on WCDMA), multiple voice channels, or multiple data channels during a single session on the cellular network.
#2	WCDMA (Voice) + WCDMA (Data)	Yes	Yes	
#3	GSM (CS Voice) + WCDMA (Data)	No	No	
#4	WCDMA (Voice) + GSM (PS Data)	No	No	
#5	GSM (PS Data) + WCDMA (Data)	No	No	
#6	GSM (CS Voice) + WCDMA (Voice)	No	No	
#7	GSM (CS Voice) + Wi-Fi	Yes	No	Supported for voice plus background data.
#8	WCDMA (Voice) + Wi-Fi	Yes	No	
#9	GSM (PS Data) + Wi-Fi	Yes	Yes	Supported for mobile hotspot operation.
#10	WCDMA (Data) + Wi-Fi	Yes	Yes	

For the transmitters requiring stand-alone SAR testing (GSM, WCDMA, and Wi-Fi 802.11), the KDB guidelines direct that if the sum of the 1 g SAR measured for the simultaneously transmitting antennas is less than the SAR limit, SAR measurement for simultaneous transmission is not required. Further, if the SAR-to-peak-location separation ratio for two simultaneously transmitting antennas is less than 0.3 then SAR measurement for simultaneous transmission is likewise not required. Evaluations of the head, body, and mobile hotspot simultaneous SAR summations for the worst-case SAR transmitter configurations are presented in the tables below.

The following SAR summations for simultaneous evaluation are provided to demonstrate a GSM or WCDMA voice link with a simultaneous data link on Wi-Fi.

Evaluations for Simultaneous SAR, Head and Body positions									
Transmitter Stand-Alone 1 g SAR Values (W/kg)						1 g SAR Summations (W/kg)			
Transmitter Combination						#7	#7	#8	#8
Band Position	GSM 850	GSM 1900	WCDMA 850	WCDMA 1900	Wi-Fi 2450	GSM 850 + Wi-Fi 2450	GSM 1900 + Wi-Fi 2450	WCDMA 850 + Wi-Fi 2450	WCDMA 1900 + Wi-Fi 2450
Left Head Check	0.32	0.47	0.31	0.90	0.55	0.87	1.02	0.86	1.45
Left Head 15° Tilt	0.21	0.19	0.23	0.36	0.07	0.28	0.26	0.30	0.43
Right Head Check	0.37	0.46	0.37	0.78	0.28	0.65	0.74	0.65	1.06
Right Head 15° Tilt	0.24	0.17	0.24	0.35	0.08	0.32	0.25	0.32	0.43
Body Worn, Front of Phone 15 mm from Phantom	0.25	0.32	0.24	0.60	0.04	0.29	0.36	0.28	0.64
Body Worn, Back of Phone 15 mm from Phantom	0.54	0.39	0.51	0.76	0.22	0.76	0.61	0.73	0.98

The following Mobile Hotspot (10 mm separation) position SAR summations for simultaneous evaluation are provided to demonstrate a data link (over GSM or WCDMA) with a simultaneous data link on Wi-Fi (to client devices).

Evaluations for Simultaneous SAR, Mobile Hotspot (10 mm separation) positions Mobile Hotspot functionality enabled									
Transmitter Stand-Alone 1 g SAR Values (W/kg)						1 g SAR Summations (W/kg)			
Transmitter Combination						#9	#9	#10	#10
Band Position	GSM 850	GSM 1900	WCDMA 850	WCDMA 1900	Wi-Fi 2450	GSM 850 + Wi-Fi 2450	GSM 1900 + Wi-Fi 2450	WCDMA 850 + Wi-Fi 2450	WCDMA 1900 + Wi-Fi 2450
Bottom Edge of DUT 10 mm from Phantom	0.09	0.59	0.10	1.23	N/A	N/A	N/A	N/A	N/A
Right Edge of DUT 10 mm from Phantom	0.40	0.14	0.38	0.30	0.24	0.64	0.38	0.62	0.54
Left Edge of DUT 10 mm from Phantom	0.38	0.19	0.18	0.36	0.27	0.65	0.46	0.45	0.63
Front Surface of DUT 10 mm from Phantom	0.56	0.49	0.30	1.11	0.11	0.67	0.60	0.41	1.22
Back Surface of DUT 10 mm from Phantom	1.14	0.55	0.67	1.32	0.45	1.59	1.00	1.12	>1.60

The single condition noted above requires a simultaneous SAR measurement.

Simultaneous Transmit Measurement:

For the configurations noted as requiring simultaneous SAR evaluation, combined SAR measurements were required to determine the aggregate 1 g SAR. Because the simple summed SAR for WCDMA 1900 and WiFi 802.11b resulted in the highest simple summed SAR value and will be evaluated with additional SAR measurements for simultaneous transmission evaluation.

Each of the single transmitters is measured using an extended zoom scan. This extended zoom scan was created to encompass the zoom scan volumes that were found previously in each of the stand-alone transmit SAR tests. The outer dimensions of the extended zoom scan were X = 72 mm, Y = 80 mm, Z = 30 mm with a step size of X = 8 mm, Y = 8 mm, and Z = 5 mm.

The location of these extended zoom scans was established by using X, Y grid offsets from the "Grid Reference Point" in DASY4.7. The results were then combined via the DASY4.7 Multi-Band Combiner feature. A comparison can be performed between the stand-alone measurements for each noted transmitter and the measurements provided for simultaneous transmission. The measurements were not performed sequentially and thus may show slightly different results due to a number of reasons including, but not limited to, measurement system performance, slight differences in DUT positioning, or variations in simulated tissue parameters. The results of these measurements are given in the table below, with additional SAR plots of the combined measurements provided in Appendix 5.

Measurements for Simultaneous SAR					
Cellular Transmitter Mode	Wi-Fi Transmitter Mode	Configuration	Cellular Transmitter 1 g SAR Value (W/kg)	Wi-Fi Transmitter 1 g SAR Value (W/kg)	Simultaneous 1 g SAR Value (W/kg)
WCDMA 1900	Wi-Fi 2450 802.11b, 11 Mbps	Body Worn 10mm	1.22	0.418	1.33

References

- [1] CENELEC, en62209-1:2006 “Human Exposure to Radio Frequency Fields From Hand - Held and Body - Mounted Wireless Communication Devices – Human Models, Instrumentation, and Procedures”
- [2] CENELEC, en50360:2001 “Product standard to demonstrate the compliance of mobile phones with the basic restrictions related to human exposure to electromagnetic fields (300MHz – 3GHz)”.
- [3] ANSI / IEEE, C95.1 1999 Edition “IEEE Standard for Safety Levels with Respect to Human Exposure to Radio Frequency Electromagnetic Fields, 3kHz to 300GHz”
- [4] FCC OET Bulletin 65 Supplement C 01-01
- [5] IEEE 1528 2003 Edition “IEEE Recommended Practice for Determining the Peak Spatial-Average Specific Absorption Rate (SAR) in the Human Head from Wireless Communications Devices: Measurement Techniques”
- [6] ICNIRP Guidelines “Guidelines for Limiting Exposure to Time-Varying Electric, Magnetic, and Electromagnetic Fields (up to 300 GHz)”

Appendix 1

SAR distribution comparison for the system accuracy verification

System Accuracy Verification Measurements for Head SAR Measurements

Test Laboratory: Motorola Mobility 835 MHz System Performance Check

DUT: Dipole 835 MHz; Type: D835V2; Serial: D835V2 - SN:436

Procedure Notes: PM1 Power = 200 mW Refl.Pwr PM3 = -26.18 dB [Sim.Temp@SPC](#) = 20.5°C Room Temp @ SPC = 20.8°C

Communication System: CW - Dipole; Frequency: 835 MHz; Duty Cycle: 1:1

Medium: Validation *HEAD Tissue* ; Medium parameters used: $f = 835 \text{ MHz}$; $\sigma = 0.92 \text{ mho/m}$; $\epsilon_r = 41.9$; $\rho = 1000 \text{ kg/m}^3$

DASY4 Configuration:

- Probe: ES3DV3 - SN3184; ConvF(6.11, 6.11, 6.11); Calibrated: 3/11/2011
- Sensor-Surface: 4mm (Mechanical Surface Detection)
- Electronics: DAE4 Sn702; Calibrated: 4/14/2011
- Phantom: R#2_Sugar SAM (extended range), Rev.1 (25-Mar-05); Type: SAM v4.0; Serial: TP-1235;
- Measurement SW: DASY4, V4.7 Build 80; Postprocessing SW: SEMCAD, V1.8 Build 186

Daily SPC Check/Dipole Area Scan (5x15x1): Measurement grid: dx=10mm, dy=15mm

Maximum value of SAR (measured) = 2.15 mW/g

Daily SPC Check/0-Degree, 5x5x7 Cube (5x5x7)/Cube 0: Measurement grid: dx=8mm, dy=8mm, dz=5mm

Reference Value = 49.0 V/m; Power Drift = -0.016 dB

Peak SAR (extrapolated) = 2.99 W/kg

SAR(1 g) = 2.01 mW/g; SAR(10 g) = 1.32 mW/g

Maximum value of SAR (measured) = 2.17 mW/g

Daily SPC Check/Z-Axis Retraction (1x1x31): Measurement grid: dx=20mm, dy=20mm, dz=5mm

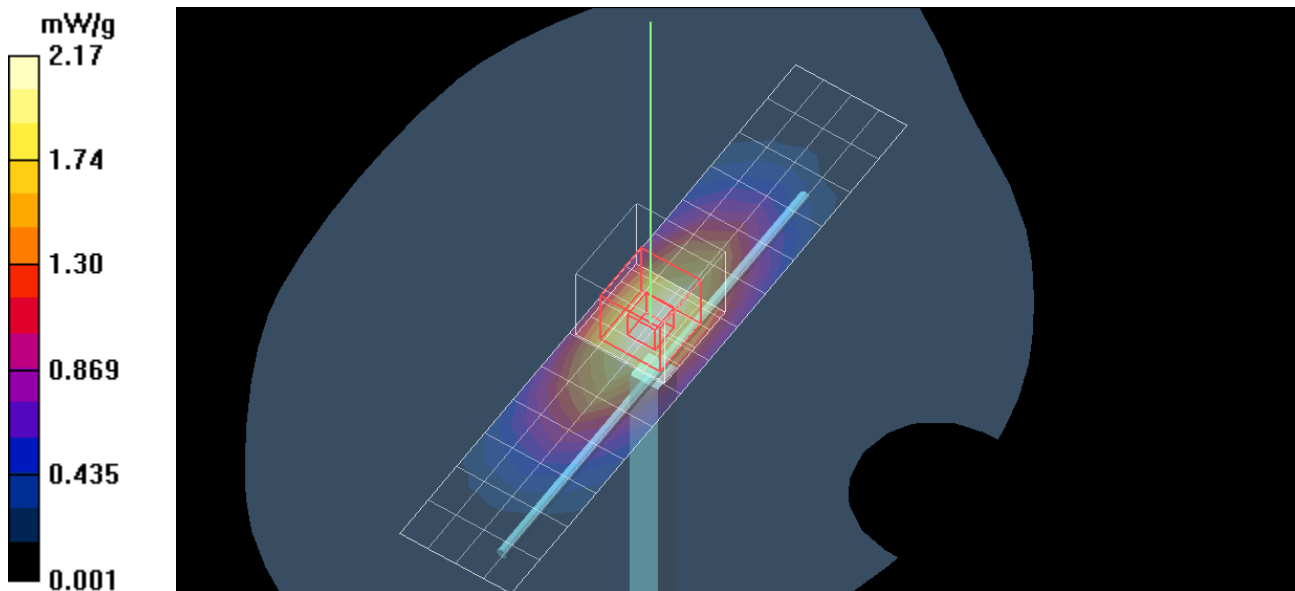

SAR(x,y,z,f0)

SAR; Z-Axis Retraction: Value Along Z, X=0, Y=0

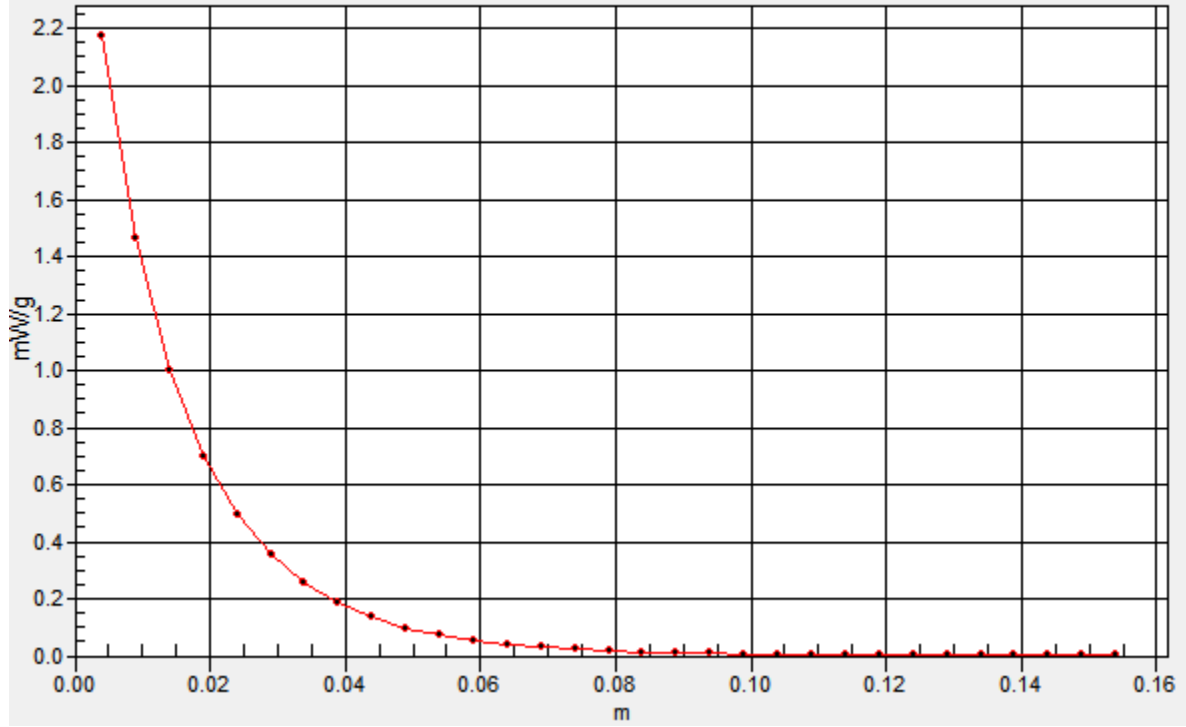

Test Laboratory: Motorola Mobility 1800 MHz System Performance Check

DUT: Dipole 1800 MHz; Type: D1800V2; Serial: D1800V2 - SN:271

Procedure Notes: PM1 Power = 200 mW Refl.Pwr PM3 = -23.75 dB [Sim.Temp@SPC](#) = 20.5°C Room Temp @ SPC = 21.1°C

Communication System: CW - Dipole; Frequency: 1800 MHz; Duty Cycle: 1:1

Medium: Validation *HEAD Tissue* ; Medium parameters used: $f = 1800$ MHz; $\sigma = 1.37$ mho/m; $\epsilon_r = 38.6$; $\rho = 1000$ kg/m³

DASY4 Configuration:

- Probe: ES3DV3 - SN3184; ConvF(5.11, 5.11, 5.11); Calibrated: 3/11/2011
- Sensor-Surface: 4mm (Mechanical Surface Detection)
- Electronics: DAE4 Sn702; Calibrated: 4/14/2011
- Phantom: R#2_ Section 1, Amy Twin, Rev3 (3-Feb-10); Type: Amy Twin Flat; Serial: n/a;
- Measurement SW: DASY4, V4.7 Build 80; Postprocessing SW: SEMCAD, V1.8 Build 186

Daily SPC Check/Dipole Area Scan (9x4x1): Measurement grid: dx=15mm, dy=15mm

Maximum value of SAR (measured) = 6.49 mW/g

Daily SPC Check/0-Degree 5x5x7 Cube (5x5x7)/Cube 0: Measurement grid: dx=8mm, dy=8mm, dz=5mm

Reference Value = 81.9 V/m; Power Drift = -0.006 dB

Peak SAR (extrapolated) = 14.6 W/kg

SAR(1 g) = 7.98 mW/g; SAR(10 g) = 4.21 mW/g

Maximum value of SAR (measured) = 8.95 mW/g

Daily SPC Check/Z-Axis Retraction (1x1x31): Measurement grid: dx=20mm, dy=20mm, dz=5mm

Maximum value of SAR (measured) = 8.92 mW/g

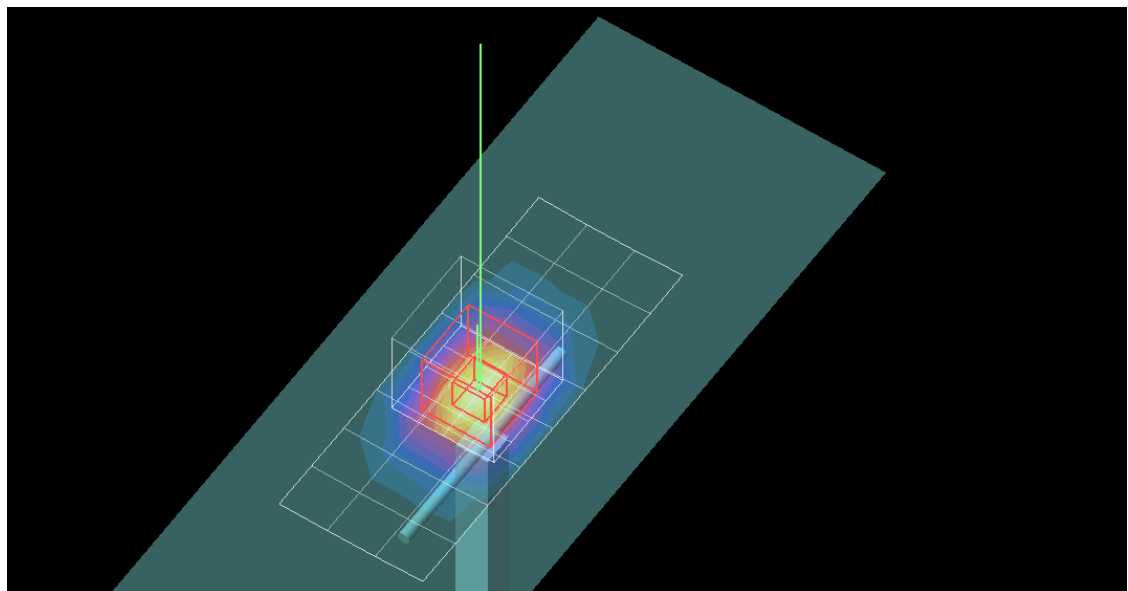
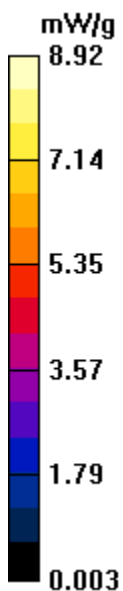

SAR(x,y,z,f0)

SAR; Z-Axis Retraction: Value Along Z, X=0, Y=0

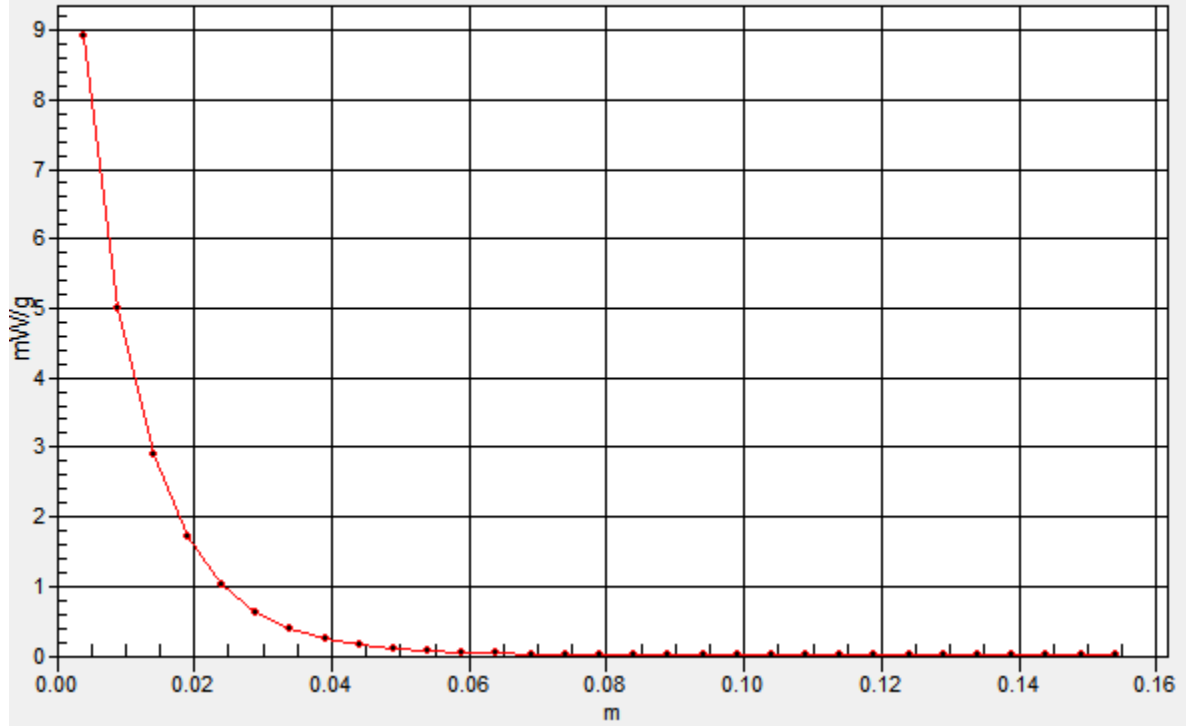

Test Laboratory: Motorola Mobility 1800 MHz System Performance Check

DUT: Dipole 1800 MHz; Type: D1800V2; Serial: D1800V2 - SN:271

Procedure Notes: PM1 Power = 200 mW Refl.Pwr PM3 = -25.00 dB [Sim.Temp@SPC](#) = 20.2 Room Temp @ SPC = 21.1°C

Communication System: CW - Dipole; Frequency: 1800 MHz; Duty Cycle: 1:1

Medium: Validation *HEAD Tissue* ; Medium parameters used: $f = 1800$ MHz; $\sigma = 1.38$ mho/m; $\epsilon_r = 38.5$; $\rho = 1000$ kg/m³

DASY4 Configuration:

- Probe: ES3DV3 - SN3184; ConvF(5.11, 5.11, 5.11); Calibrated: 3/11/2011
- Sensor-Surface: 4mm (Mechanical Surface Detection)
- Electronics: DAE4 Sn702; Calibrated: 4/14/2011
- Phantom: R#2 Glycol SAM (extended range), Rev.1 (25-Mar-05); Type: SAM v4.0; Serial: TP-1136;
- Measurement SW: DASY4, V4.7 Build 80; Postprocessing SW: SEMCAD, V1.8 Build 186

Daily SPC Check/Dipole Area Scan (5x15x1): Measurement grid: dx=10mm, dy=15mm

Maximum value of SAR (measured) = 8.54 mW/g

Daily SPC Check/0-Degree, 5x5x7 Cube (5x5x7)/Cube 0: Measurement grid: dx=8mm, dy=8mm, dz=5mm

Reference Value = 79.6 V/m; Power Drift = -0.030 dB

Peak SAR (extrapolated) = 14.1 W/kg

SAR(1 g) = 7.72 mW/g; SAR(10 g) = 4.08 mW/g

Maximum value of SAR (measured) = 8.64 mW/g

Daily SPC Check/Z-Axis Retraction (1x1x31): Measurement grid: dx=20mm, dy=20mm, dz=5mm

Maximum value of SAR (measured) = 8.62 mW/g

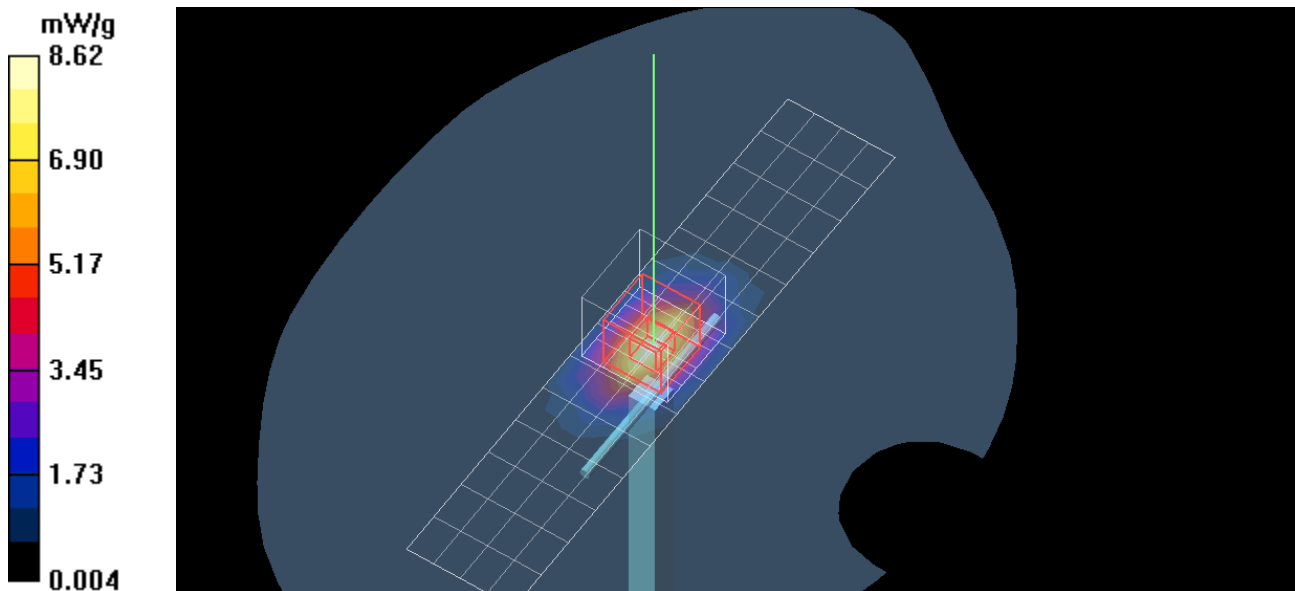

SAR(x,y,z,f0)

SAR; Z-Axis Retraction: Value Along Z, X=0, Y=0

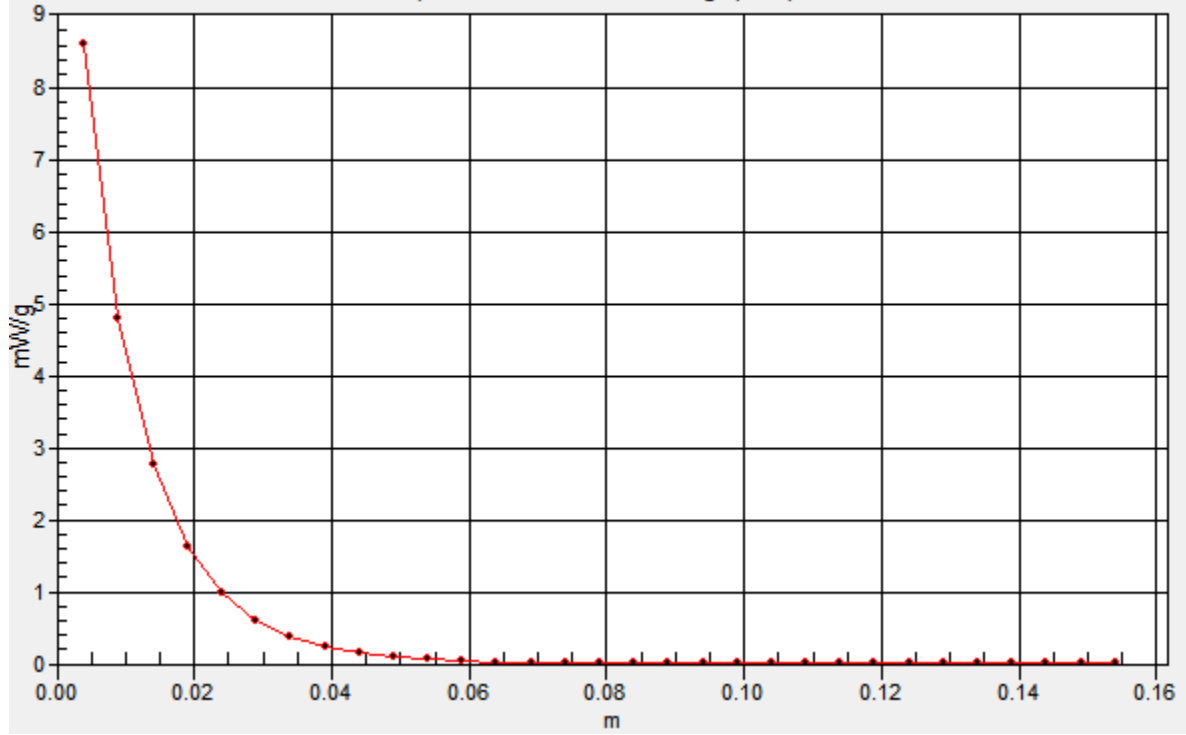

Test Laboratory: Motorola 2450 MHz System Performance Check

DUT: Dipole 2450 MHz; Type: D2450V2; Serial: D2450V2 - SN:766

Procedure Notes: PM1 Power = 200mW Refl.Pwr PM3 = -21.2dB [Sim.Temp@SPC](#) = 20.2°C Room Temp @ SPC = 21.1°C

Communication System: CW - Dipole; Frequency: 2450 MHz; Duty Cycle: 1:1

Medium: Validation *HEAD Tissue* ; Medium parameters used: $f = 2450$ MHz; $\sigma = 1.85$ mho/m; $\epsilon_r = 36.3$; $\rho = 1000$ kg/m³

DASY4 Configuration:

- Probe: ES3DV3 - SN3115; ConvF(4.39, 4.39, 4.39); Calibrated: 1/12/2011
- Sensor-Surface: 4mm (Mechanical Surface Detection)
- Electronics: DAE3 Sn434; Calibrated: 1/13/2011
- Phantom: R4 : Sect.1, Amy Twin, Rev.3 (3-Feb-10); Type: Amy Twin Flat; Serial: n/a;
- Measurement SW: DASY4, V4.7 Build 80; Postprocessing SW: SEMCAD, V1.8 Build 186

Daily SPC Check/Dipole Area Scan (9x4x1): Measurement grid: dx=15mm, dy=15mm

Maximum value of SAR (measured) = 10.4 mW/g

Daily SPC Check/0-Degree 5x5x7 Cube (5x5x7)/Cube 0: Measurement grid: dx=8mm, dy=8mm, dz=5mm

Reference Value = 84.7 V/m; Power Drift = 0.006 dB

Peak SAR (extrapolated) = 25.1 W/kg

SAR(1 g) = 11.5 mW/g; SAR(10 g) = 5.3 mW/g

Maximum value of SAR (measured) = 13.0 mW/g

Daily SPC Check/Z-Axis Retraction (1x1x31): Measurement grid: dx=20mm, dy=20mm, dz=5mm

Maximum value of SAR (measured) = 13.1 mW/g

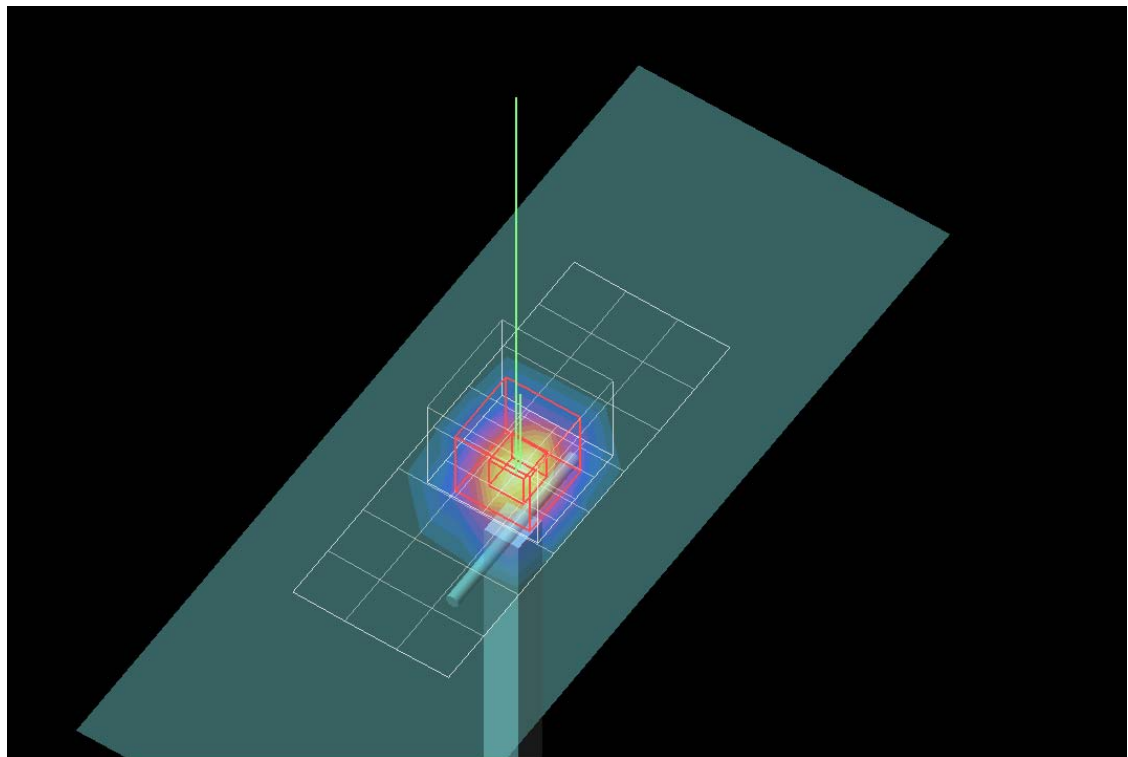
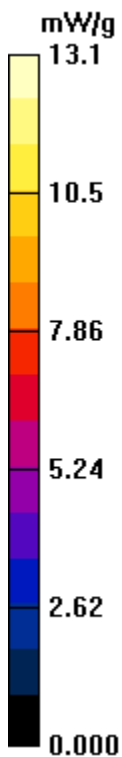

SAR(x,y,z,f0)

SAR; Z-Axis Retraction: Value Along Z, X=0, Y=0

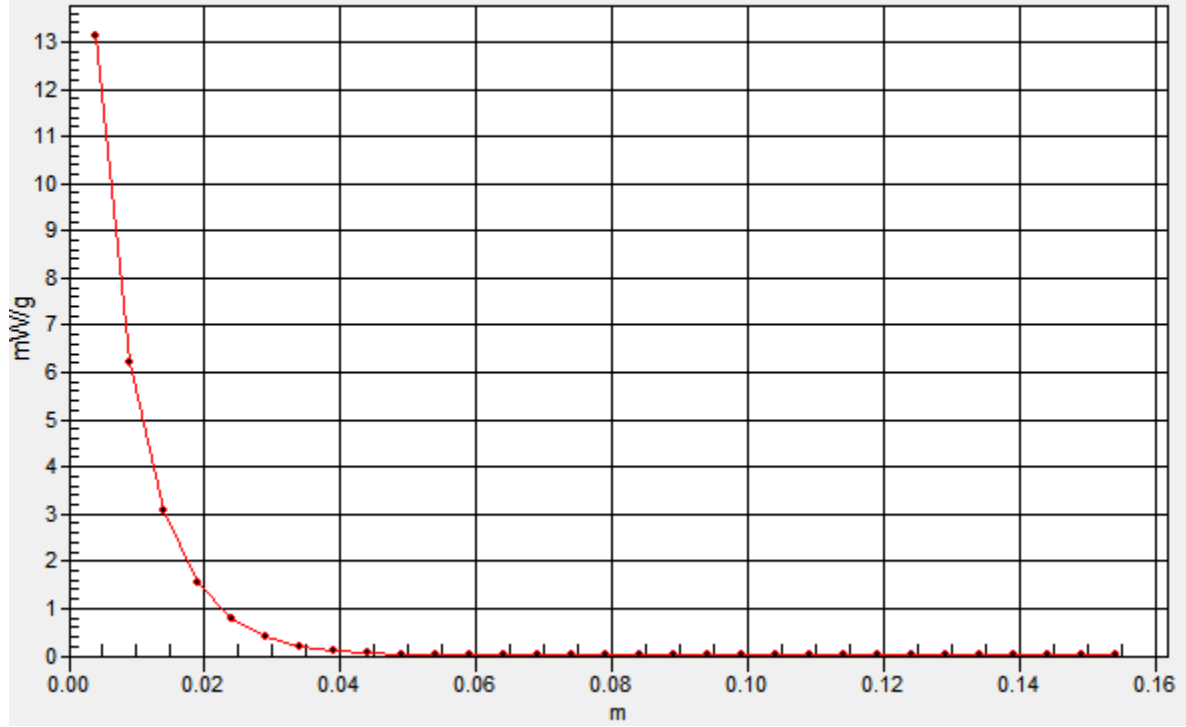

System Accuracy Verification Measurements for Body SAR Measurements

Test Laboratory: Motorola Mobility 835 MHz System Performance Check

DUT: Dipole 835 MHz; Type: D835V2; Serial: D835V2 - SN:436

Procedure Notes: PM1 Power = 200 mW Refl.Pwr PM3 = -20.80 dB [Sim.Temp@SPC](#) = 20.5°C Room Temp @ SPC = 20.9°C

Communication System: CW - Dipole; Frequency: 835 MHz; Duty Cycle: 1:1

Medium: Validation *BODY Tissue* ; Medium parameters used: $f = 835 \text{ MHz}$; $\sigma = 0.98 \text{ mho/m}$; $\epsilon_r = 55.1$; $\rho = 1000 \text{ kg/m}^3$

DASY4 Configuration:

- Probe: ES3DV3 - SN3184; ConvF(6.1, 6.1, 6.1); Calibrated: 3/11/2011
- Sensor-Surface: 4mm (Mechanical Surface Detection)
- Electronics: DAE4 Sn702; Calibrated: 4/14/2011
- Phantom: R#2_ Section 2, Amy Twin, Rev3 (3-Feb-10); Type: Amy Twin Flat; Serial: n/a;
- Measurement SW: DASY4, V4.7 Build 80; Postprocessing SW: SEMCAD, V1.8 Build 186

Daily SPC Check/Dipole Area Scan (9x4x1): Measurement grid: dx=15mm, dy=15mm

Maximum value of SAR (measured) = 1.89 mW/g

Daily SPC Check/0-Degree 5x5x7 Cube (5x5x7)/Cube 0: Measurement grid: dx=8mm, dy=8mm, dz=5mm

Reference Value = 46.9 V/m; Power Drift = 0.004 dB

Peak SAR (extrapolated) = 2.91 W/kg

SAR(1 g) = 1.98 mW/g; SAR(10 g) = 1.31 mW/g

Maximum value of SAR (measured) = 2.13 mW/g

Daily SPC Check/Z-Axis Retraction (1x1x31): Measurement grid: dx=20mm, dy=20mm, dz=5mm

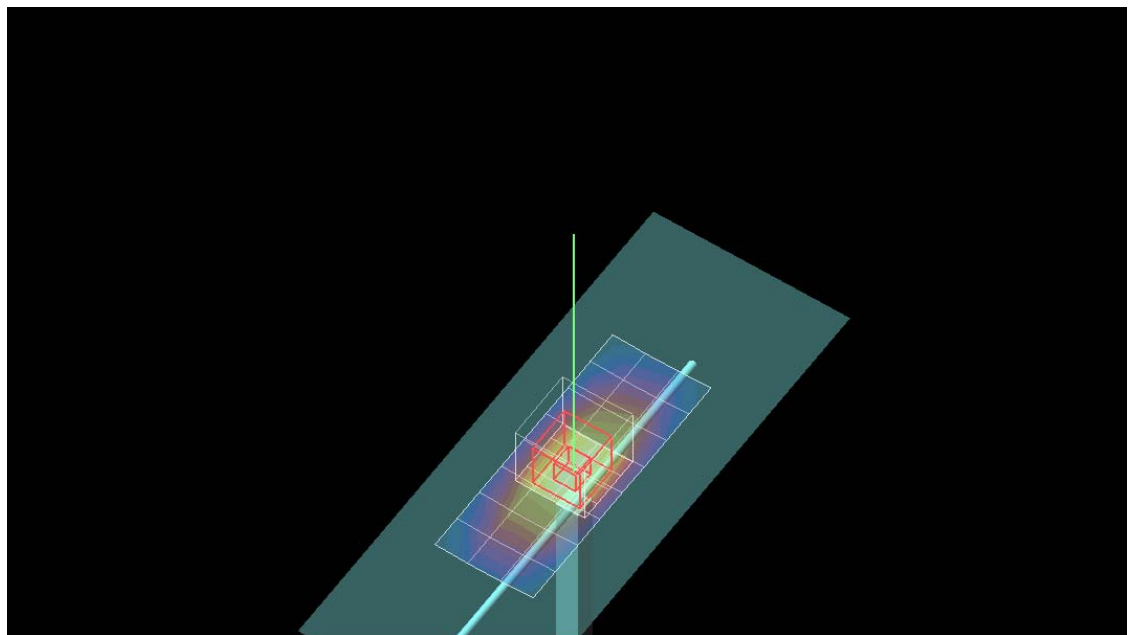
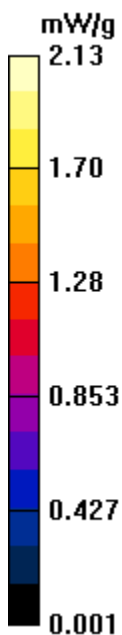

SAR(x,y,z,f0)

SAR; Z-Axis Retraction: Value Along Z, X=0, Y=0

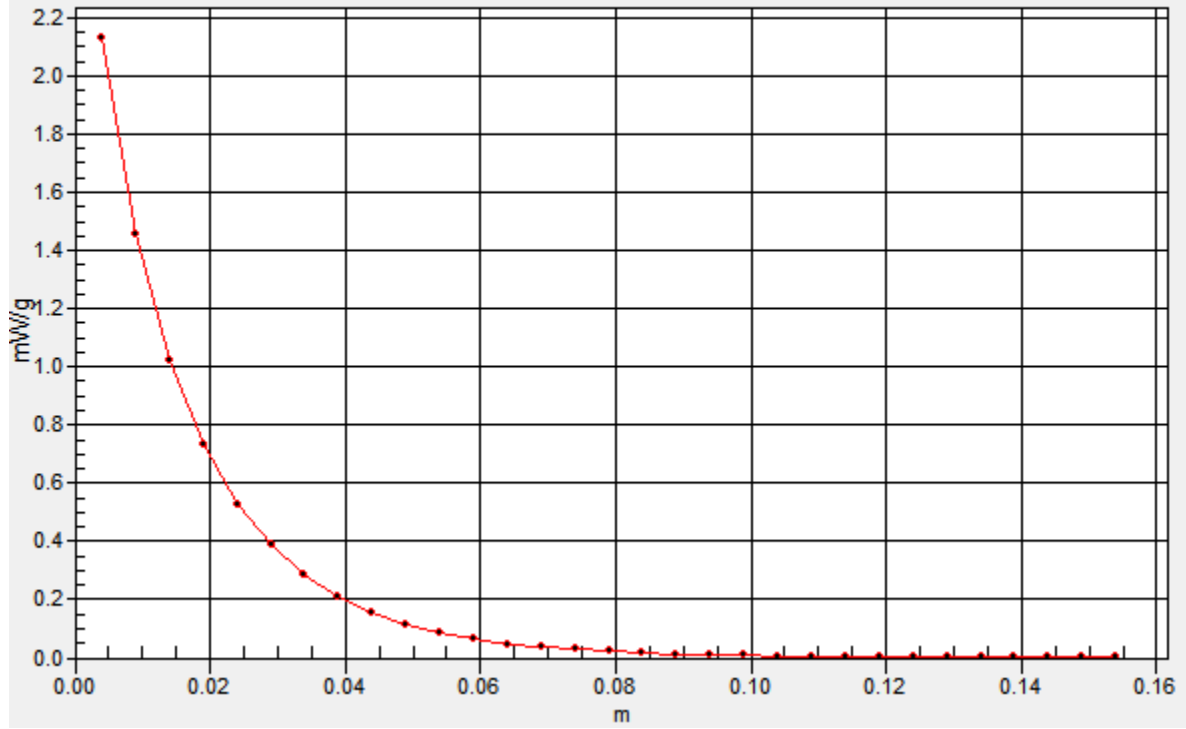

Test Laboratory: Motorola Mobility 835 MHz System Performance Check

DUT: Dipole 835 MHz; Type: D835V2; Serial: D835V2 - SN:436

Procedure Notes: PM1 Power = 199mW Refl.Pwr PM3 = -21.4dB [Sim.Temp@SPC](#) = 20.7°C Room Temp @ SPC = 21.4°C

Communication System: CW - Dipole; Frequency: 835 MHz; Duty Cycle: 1:1

Medium: Validation *BODY Tissue* ; Medium parameters used: $f = 835 \text{ MHz}$; $\sigma = 0.97 \text{ mho/m}$; $\epsilon_r = 54.6$; $\rho = 1000 \text{ kg/m}^3$

DASY4 Configuration:

- Probe: ES3DV3 - SN3184; ConvF(6.1, 6.1, 6.1); Calibrated: 3/11/2011
- Sensor-Surface: 4mm (Mechanical Surface Detection)
- Electronics: DAE4 Sn702; Calibrated: 4/14/2011
- Phantom: R#2_Section 2, Amy Twin, Rev3 (3-Feb-10); Type: Amy Twin Flat; Serial: n/a;
- Measurement SW: DASY4, V4.7 Build 80; Postprocessing SW: SEMCAD, V1.8 Build 186

Daily SPC Check/Dipole Area Scan (9x4x1): Measurement grid: dx=15mm, dy=15mm

Maximum value of SAR (measured) = 1.78 mW/g

Daily SPC Check/0-Degree 5x5x7 Cube (5x5x7)/Cube 0: Measurement grid: dx=8mm, dy=8mm, dz=5mm

Reference Value = 46.7 V/m; Power Drift = -0.022 dB

Peak SAR (extrapolated) = 2.85 W/kg

SAR(1 g) = 1.93 mW/g; SAR(10 g) = 1.27 mW/g

Maximum value of SAR (measured) = 2.08 mW/g

Daily SPC Check/Z-Axis Retraction (1x1x31): Measurement grid: dx=20mm, dy=20mm, dz=5mm

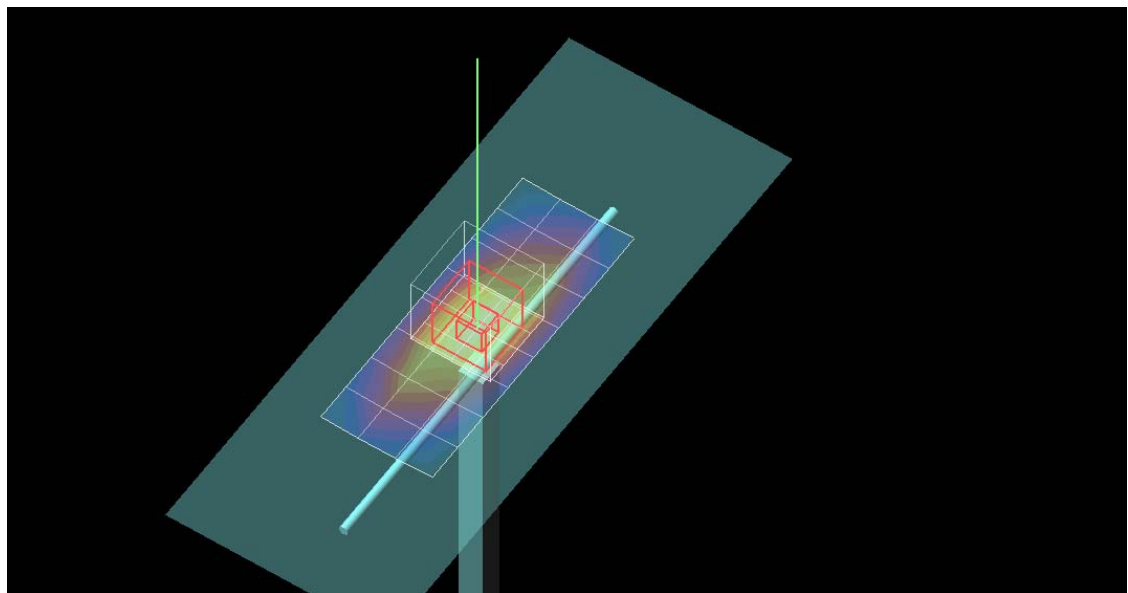
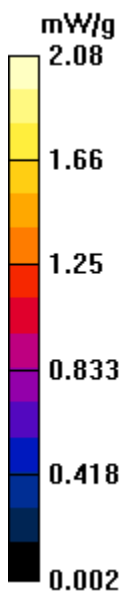

SAR(x,y,z,f0)

SAR; Z-Axis Retraction: Value Along Z, X=0, Y=0

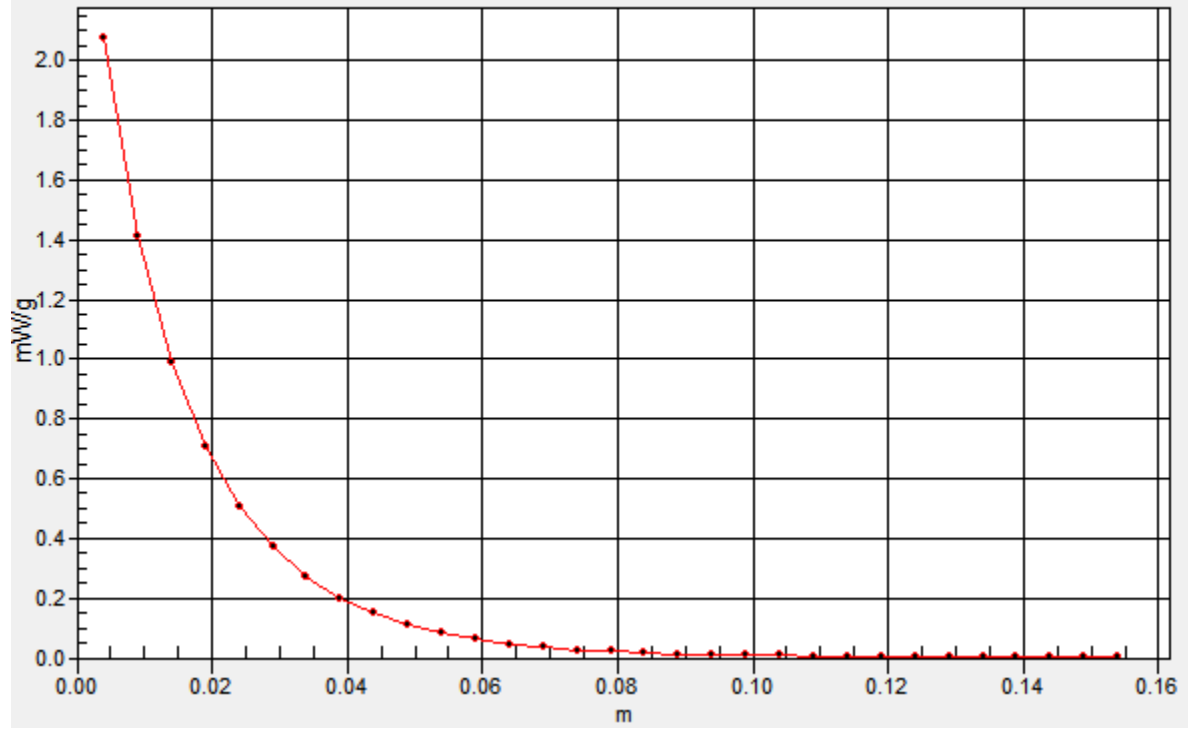

Test Laboratory: Motorola Mobility 835 MHz System Performance Check

DUT: Dipole 835 MHz; Type: D835V2; Serial: D835V2 - SN:436

Procedure Notes: PM1 Power = 200 mW Refl.Pwr PM3 = -20.6 dB [Sim.Temp@SPC](#) = 20.2 Room Temp @ SPC = 21.6

Communication System: CW - Dipole; Frequency: 835 MHz; Duty Cycle: 1:1

Medium: Validation *BODY Tissue* ; Medium parameters used: $f = 835$ MHz; $\sigma = 0.98$ mho/m; $\epsilon_r = 54.4$; $\rho = 1000$ kg/m³

DASY4 Configuration:

- Probe: ES3DV3 - SN3184; ConvF(6.1, 6.1, 6.1); Calibrated: 3/11/2011
- Sensor-Surface: 4mm (Mechanical Surface Detection)
- Electronics: DAE4 Sn702; Calibrated: 4/14/2011
- Phantom: R#2_ Section 2, Amy Twin, Rev3 (3-Feb-10); Type: Amy Twin Flat; Serial: n/a;
- Measurement SW: DASY4, V4.7 Build 80; Postprocessing SW: SEMCAD, V1.8 Build 186

Daily SPC Check/Dipole Area Scan (9x4x1): Measurement grid: dx=15mm, dy=15mm

Maximum value of SAR (measured) = 1.84 mW/g

Daily SPC Check/0-Degree 5x5x7 Cube (5x5x7)/Cube 0: Measurement grid: dx=8mm, dy=8mm, dz=5mm

Reference Value = 46.7 V/m; Power Drift = -0.012 dB

Peak SAR (extrapolated) = 2.86 W/kg

SAR(1 g) = 1.94 mW/g; SAR(10 g) = 1.28 mW/g

Maximum value of SAR (measured) = 2.10 mW/g

Daily SPC Check/Z-Axis Retraction (1x1x31): Measurement grid: dx=20mm, dy=20mm, dz=5mm

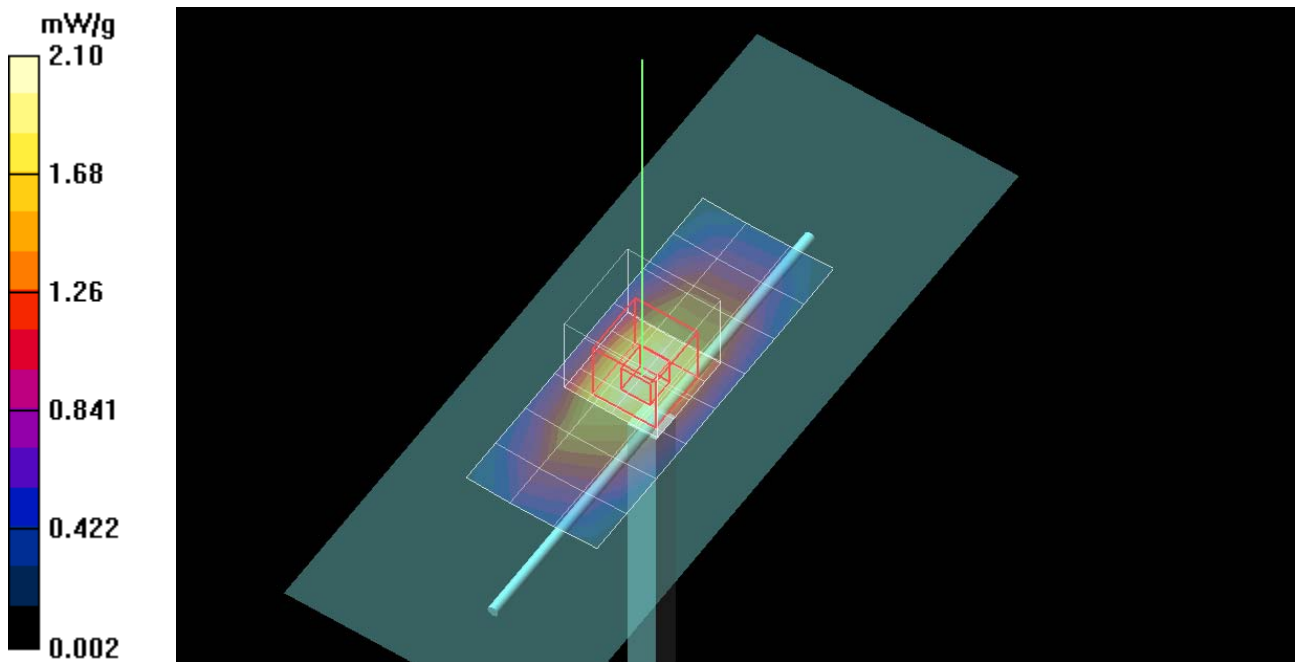

SAR(x,y,z,f0)

SAR; Z-Axis Retraction: Value Along Z, X=0, Y=0

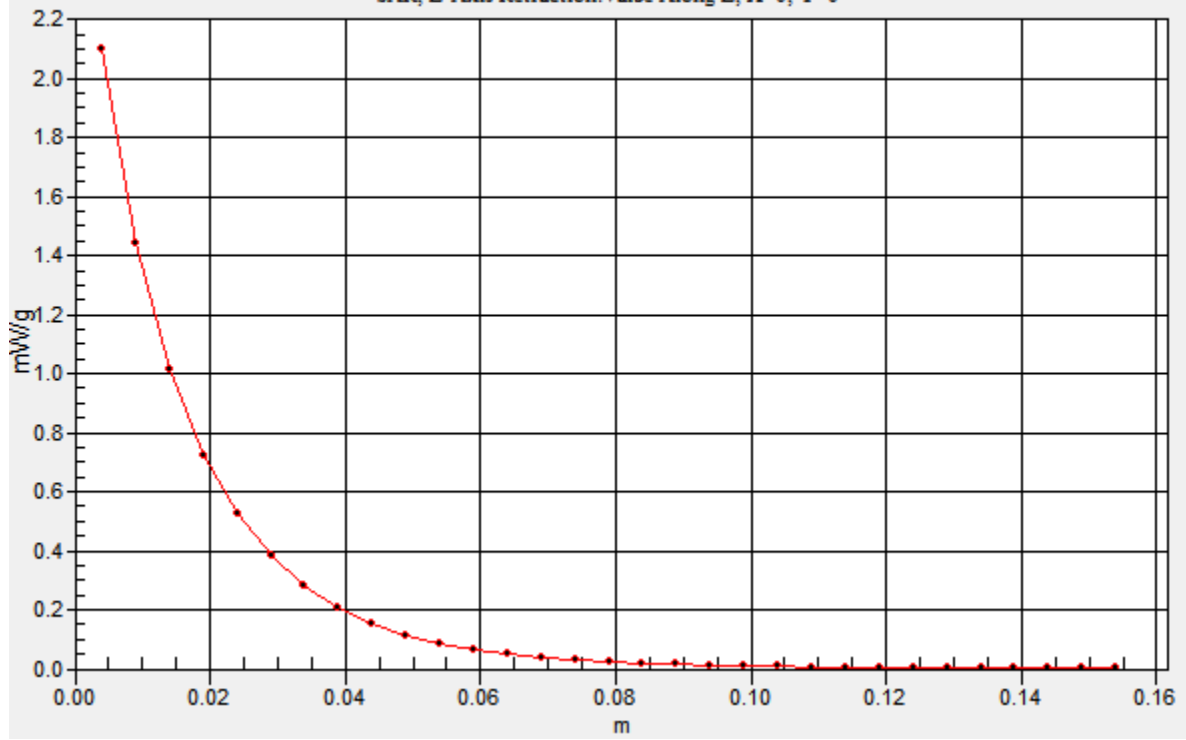

Test Laboratory: Motorola Mobility 1800 MHz System Performance Check

DUT: Dipole 1800 MHz; Type: D1800V2; Serial: D1800V2 - SN:271

Procedure Notes: PM1 Power = 200 mW Refl.Pwr PM3 = -19.95 dB [Sim.Temp@SPC](#) = 20.5C Room Temp @ SPC = 21.5C

Communication System: CW - Dipole; Frequency: 1800 MHz; Duty Cycle: 1:1

Medium: Validation *BODY Tissue* ; Medium parameters used: $f = 1800$ MHz; $\sigma = 1.47$ mho/m; $\epsilon_r = 51.3$; $\rho = 1000$ kg/m³

DASY4 Configuration:

- Probe: ES3DV3 - SN3184; ConvF(4.9, 4.9, 4.9); Calibrated: 3/11/2011
- Sensor-Surface: 4mm (Mechanical Surface Detection)
- Electronics: DAE4 Sn702; Calibrated: 4/14/2011
- Phantom: R#2_ Section 1, Amy Twin, Rev3 (3-Feb-10); Type: Amy Twin Flat; Serial: n/a;
- Measurement SW: DASY4, V4.7 Build 80; Postprocessing SW: SEMCAD, V1.8 Build 186

Daily SPC Check/Dipole Area Scan (9x4x1): Measurement grid: dx=15mm, dy=15mm

Maximum value of SAR (measured) = 6.88 mW/g

Daily SPC Check/0-Degree 5x5x7 Cube (5x5x7)/Cube 0: Measurement grid: dx=8mm, dy=8mm, dz=5mm

Reference Value = 78.2 V/m; Power Drift = 0.017 dB

Peak SAR (extrapolated) = 13.6 W/kg

SAR(1 g) = 7.77 mW/g; SAR(10 g) = 4.16 mW/g

Maximum value of SAR (measured) = 8.68 mW/g

Daily SPC Check/Z-Axis Retraction (1x1x31): Measurement grid: dx=20mm, dy=20mm, dz=5mm

Maximum value of SAR (measured) = 8.79 mW/g

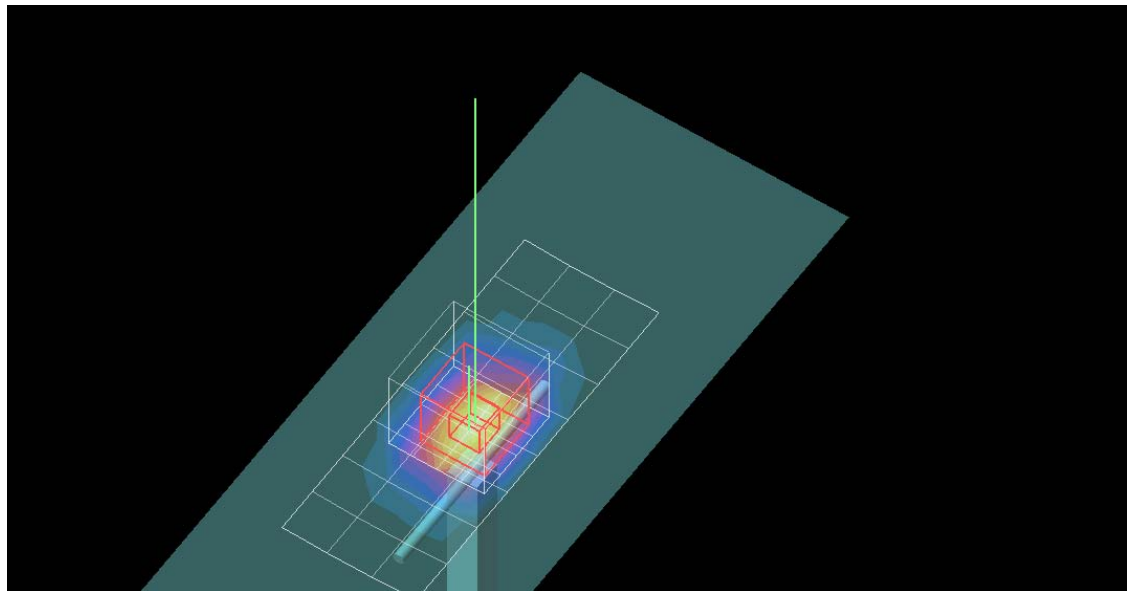
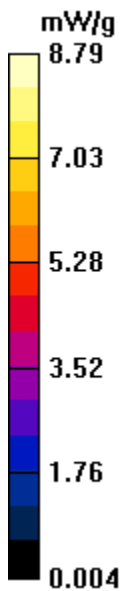

SAR(x,y,z,f0)

SAR; Z-Axis Retraction: Value Along Z, X=0, Y=0

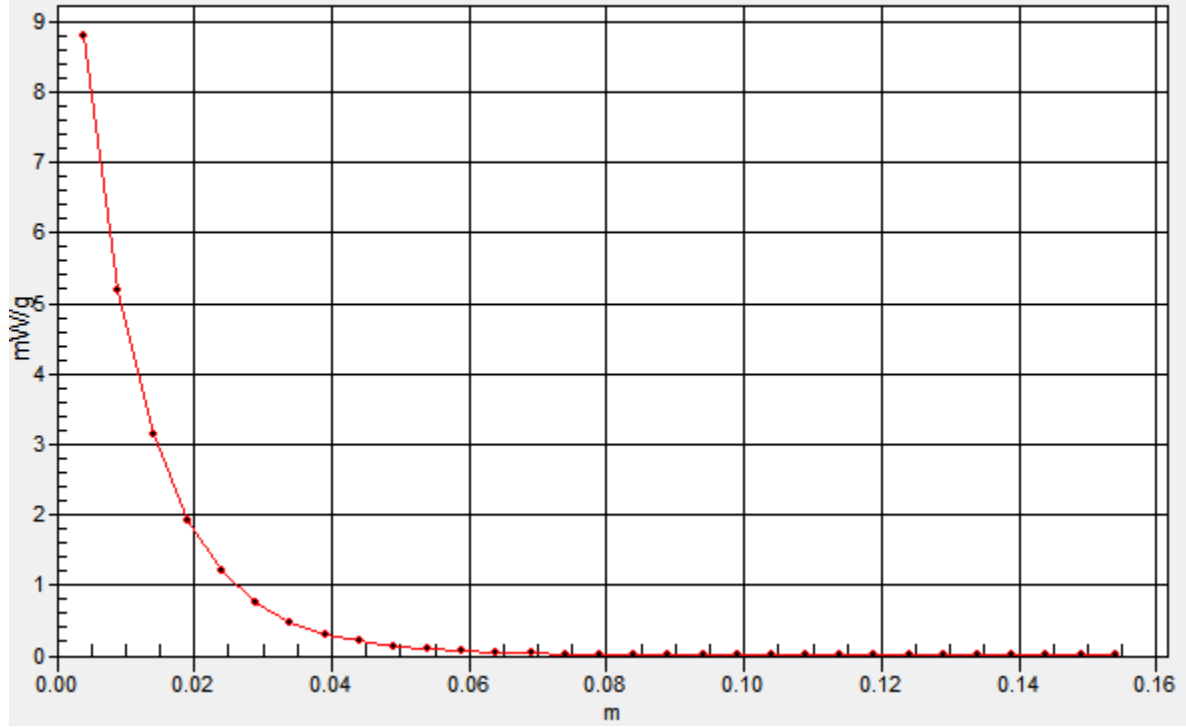

Test Laboratory: Motorola Mobility 1800 MHz System Performance Check

DUT: Dipole 1800 MHz; Type: D1800V2; Serial: D1800V2 - SN:271

Procedure Notes: PM1 Power = 200 mW Refl.Pwr PM3 = -20.35 dB [Sim.Temp@SPC](#) = 20.5°C Room Temp @ SPC = 21.0°C

Communication System: CW - Dipole; Frequency: 1800 MHz; Duty Cycle: 1:1

Medium: Validation *BODY Tissue* ; Medium parameters used: $f = 1800$ MHz; $\sigma = 1.48$ mho/m; $\epsilon_r = 51.2$; $\rho = 1000$ kg/m³

DASY4 Configuration:

- Probe: ES3DV3 - SN3184; ConvF(4.9, 4.9, 4.9); Calibrated: 3/11/2011
- Sensor-Surface: 4mm (Mechanical Surface Detection)
- Electronics: DAE4 Sn702; Calibrated: 4/14/2011
- Phantom: R#2_ Section 1, Amy Twin, Rev3 (3-Feb-10); Type: Amy Twin Flat; Serial: n/a;
- Measurement SW: DASY4, V4.7 Build 80; Postprocessing SW: SEMCAD, V1.8 Build 186

Daily SPC Check/Dipole Area Scan (9x4x1): Measurement grid: dx=15mm, dy=15mm

Maximum value of SAR (measured) = 7.74 mW/g

Daily SPC Check/0-Degree 5x5x7 Cube (5x5x7)/Cube 0: Measurement grid: dx=8mm, dy=8mm, dz=5mm

Reference Value = 76.9 V/m; Power Drift = 0.004 dB

Peak SAR (extrapolated) = 13.8 W/kg

SAR(1 g) = 7.87 mW/g; SAR(10 g) = 4.22 mW/g

Maximum value of SAR (measured) = 8.69 mW/g

Daily SPC Check/Z-Axis Retraction (1x1x31): Measurement grid: dx=20mm, dy=20mm, dz=5mm

Maximum value of SAR (measured) = 8.82 mW/g

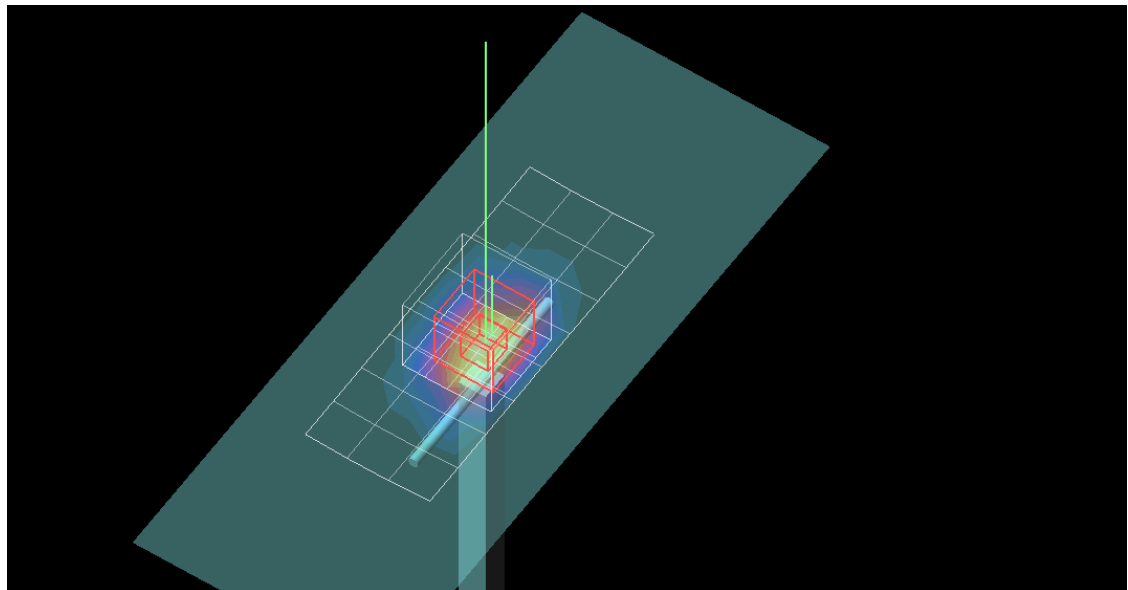
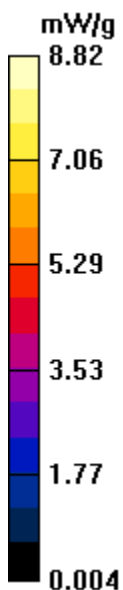

SAR(x,y,z,f0)

SAR; Z-Axis Retraction: Value Along Z, X=0, Y=0

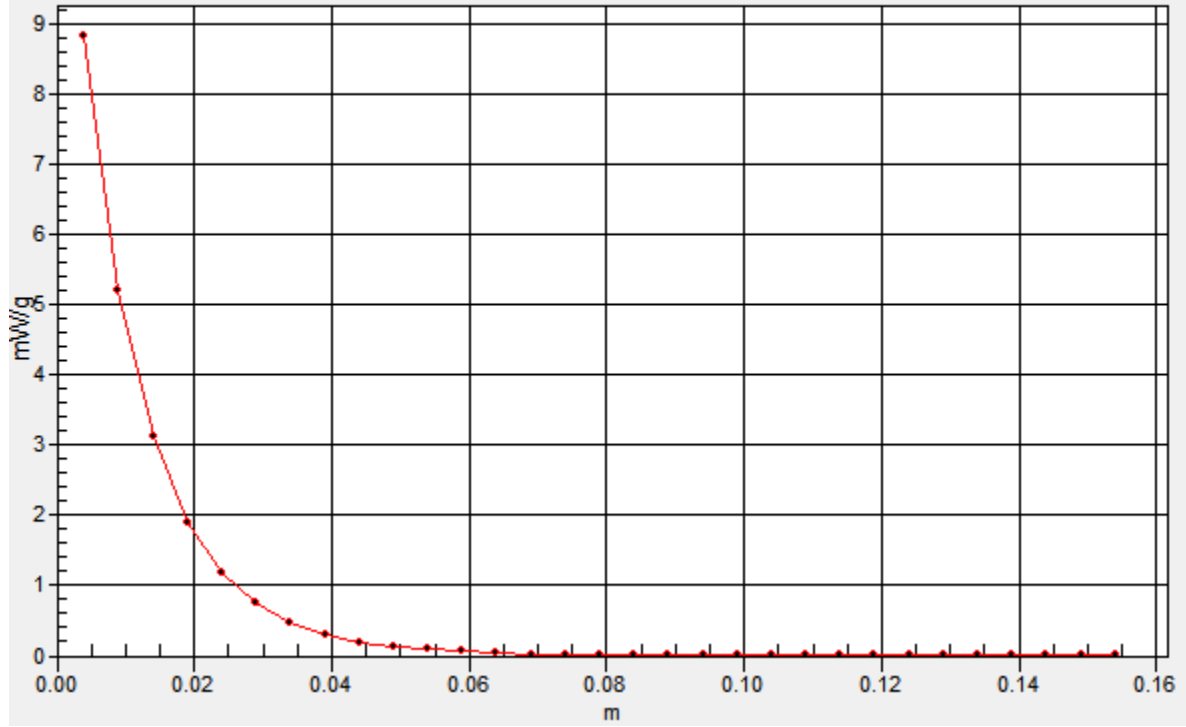

Test Laboratory: Motorola Mobility 1800 MHz System Performance Check

DUT: Dipole 1800 MHz; Type: D1800V2; Serial: D1800V2 - SN:271

Procedure Notes: PM1 Power = 200 mW Refl.Pwr PM3 = -20.25 dB [Sim.Temp@SPC](#) = 20.7C Room Temp @ SPC = 21.3C

Communication System: CW - Dipole; Frequency: 1800 MHz; Duty Cycle: 1:1

Medium: Validation *BODY Tissue* ; Medium parameters used: $f = 1800$ MHz; $\sigma = 1.49$ mho/m; $\epsilon_r = 51.1$; $\rho = 1000$ kg/m³

DASY4 Configuration:

- Probe: ES3DV3 - SN3184; ConvF(4.9, 4.9, 4.9); Calibrated: 3/11/2011
- Sensor-Surface: 4mm (Mechanical Surface Detection)
- Electronics: DAE4 Sn702; Calibrated: 4/14/2011
- Phantom: R#2_ Section 1, Amy Twin, Rev3 (3-Feb-10); Type: Amy Twin Flat; Serial: n/a;
- Measurement SW: DASY4, V4.7 Build 80; Postprocessing SW: SEMCAD, V1.8 Build 186

Daily SPC Check/Dipole Area Scan (9x4x1): Measurement grid: dx=15mm, dy=15mm

Maximum value of SAR (measured) = 8.22 mW/g

Daily SPC Check/0-Degree 5x5x7 Cube (5x5x7)/Cube 0: Measurement grid: dx=8mm, dy=8mm, dz=5mm

Reference Value = 75.3 V/m; Power Drift = -0.004 dB

Peak SAR (extrapolated) = 13.9 W/kg

SAR(1 g) = 7.95 mW/g; SAR(10 g) = 4.25 mW/g

Maximum value of SAR (measured) = 8.77 mW/g

Daily SPC Check/Z-Axis Retraction (1x1x31): Measurement grid: dx=20mm, dy=20mm, dz=5mm

Maximum value of SAR (measured) = 8.91 mW/g

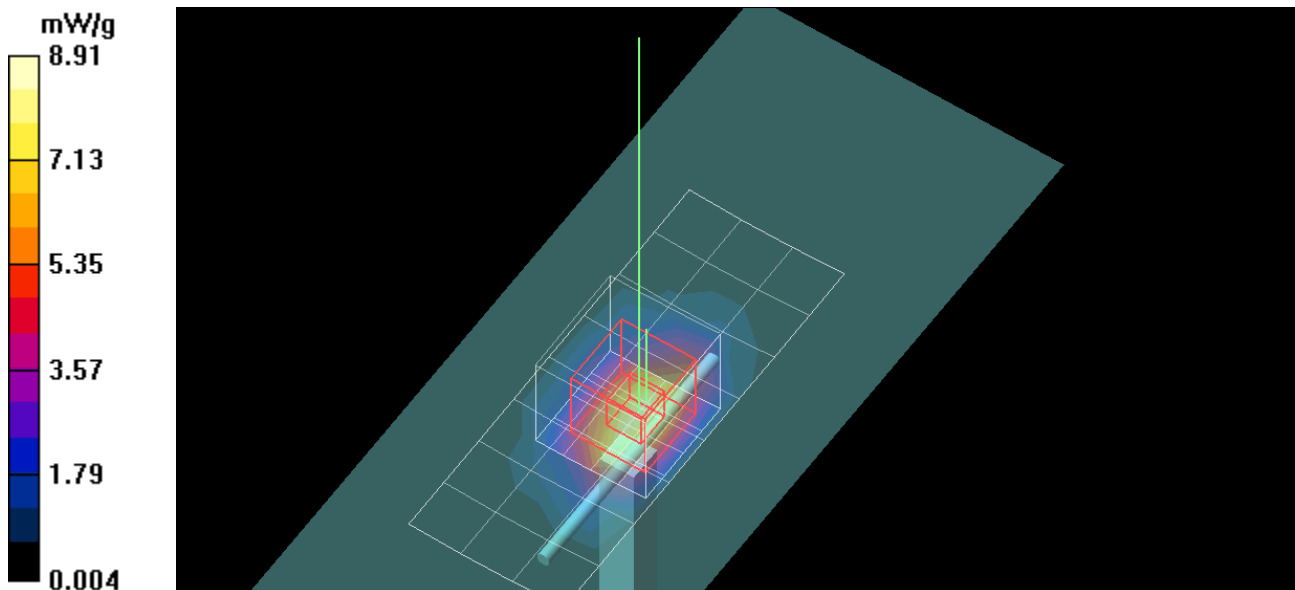

SAR(x,y,z,f0)

SAR; Z-Axis Retraction: Value Along Z, X=0, Y=0

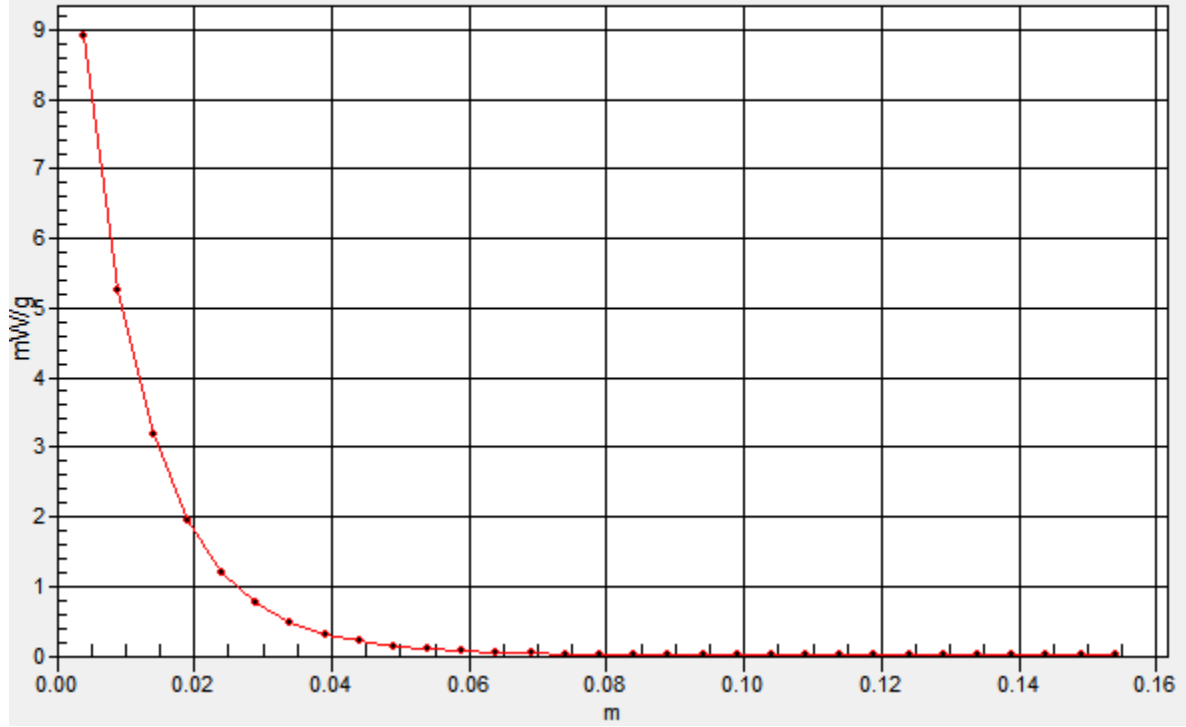

Test Laboratory: Motorola Mobility 1800 MHz System Performance Check

DUT: Dipole 1800 MHz; Type: D1800V2; Serial: D1800V2 - SN:259

Procedure Notes: PM1 Power = 200 mW Refl.Pwr PM3 = -20.5dB [Sim.Temp@SPC](#) = 20.5 Room Temp @ SPC = 21.4

Communication System: CW - Dipole; Frequency: 1800 MHz; Duty Cycle: 1:1

Medium: Validation *BODY Tissue* ; Medium parameters used: $f = 1800$ MHz; $\sigma = 1.49$ mho/m; $\epsilon_r = 51.1$; $\rho = 1000$ kg/m³

DASY4 Configuration:

- Probe: ES3DV3 - SN3184; ConvF(4.9, 4.9, 4.9); Calibrated: 3/11/2011
- Sensor-Surface: 4mm (Mechanical Surface Detection)
- Electronics: DAE4 Sn702; Calibrated: 4/14/2011
- Phantom: R#2 Glycol SAM (extended range), Rev.1 (25-Mar-05); Type: SAM v4.0; Serial: TP-1136;
- Measurement SW: DASY4, V4.7 Build 80; Postprocessing SW: SEMCAD, V1.8 Build 186

Daily SPC Check/Dipole Area Scan (5x15x1): Measurement grid: dx=10mm, dy=15mm

Maximum value of SAR (measured) = 9.01 mW/g

Daily SPC Check/0-Degree, 5x5x7 Cube (5x5x7)/Cube 0: Measurement grid: dx=8mm, dy=8mm, dz=5mm

Reference Value = 79.2 V/m; Power Drift = -0.023 dB

Peak SAR (extrapolated) = 14.0 W/kg

SAR(1 g) = 8 mW/g; SAR(10 g) = 4.29 mW/g

Maximum value of SAR (measured) = 9.00 mW/g

Daily SPC Check/Z-Axis Retraction (1x1x31): Measurement grid: dx=20mm, dy=20mm, dz=5mm

Maximum value of SAR (measured) = 8.98 mW/g

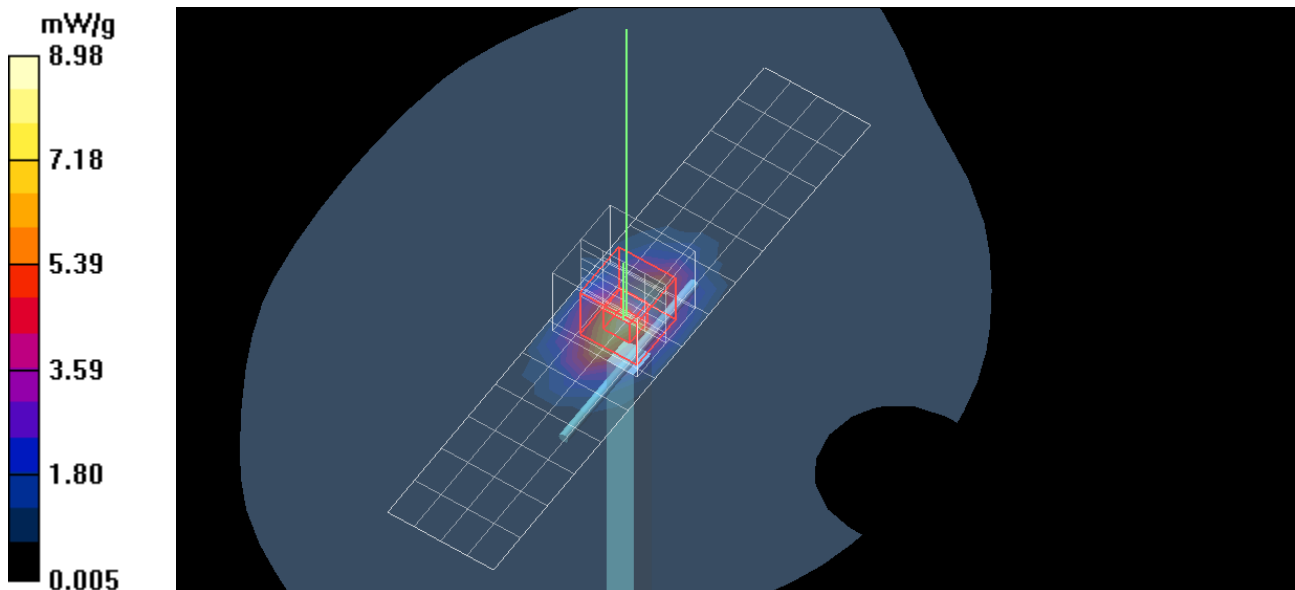

SAR(x,y,z,f0)

SAR; Z-Axis Retraction: Value Along Z, X=0, Y=0

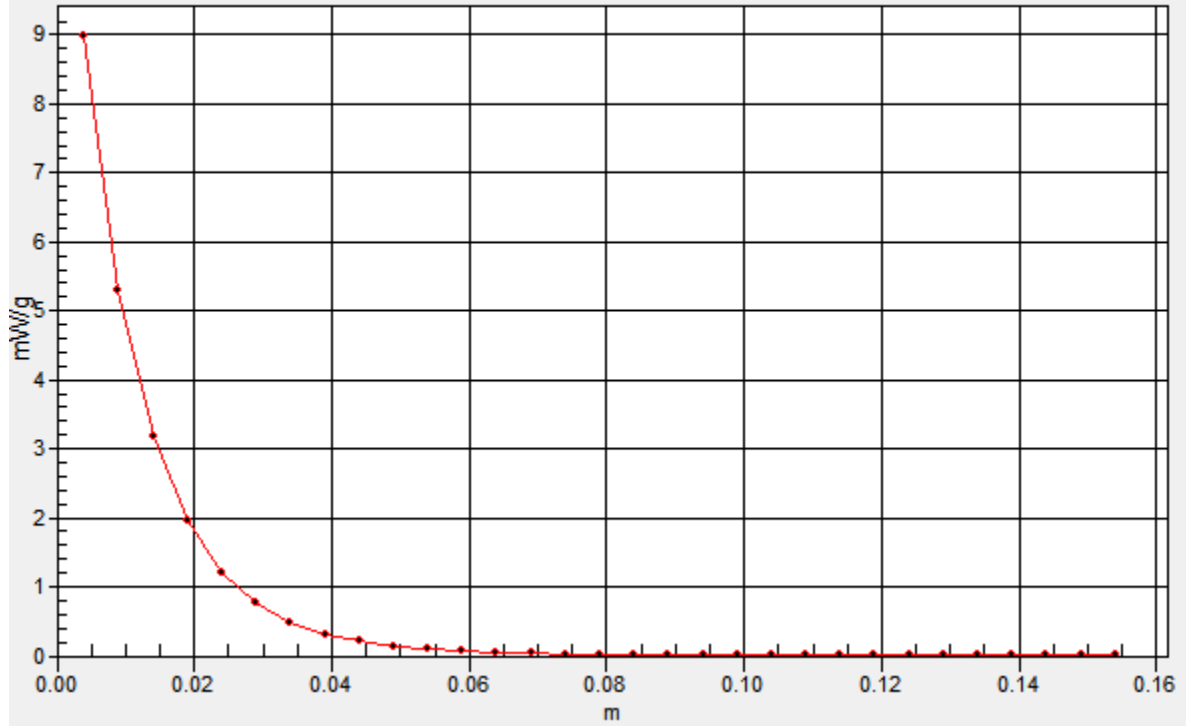

Test Laboratory: Motorola 2450 MHz System Performance Check

DUT: Dipole 2450 MHz; Type: D2450V2; Serial: D2450V2 - SN:766

Procedure Notes: PM1 Power = 200mW Refl.Pwr PM3= -24.95dB [Sim.Temp@SPC](#) = 20.4 Room Temp @ SPC = 21

Communication System: CW - Dipole; Frequency: 2450 MHz; Duty Cycle: 1:1

Medium: Validation *HEAD Tissue* ; Medium parameters used: $f = 2450$ MHz; $\sigma = 2.03$ mho/m; $\epsilon_r = 47.9$; $\rho = 1000$ kg/m³

DASY4 Configuration:

- Probe: ES3DV3 - SN3037; ConvF(4.24, 4.24, 4.24); Calibrated: 4/13/2011
- Sensor-Surface: 4mm (Mechanical Surface Detection)
- Electronics: DAE4 Sn702; Calibrated: 4/14/2011
- Phantom: R1_Glycol, SAM (extended range), Rev.1 (25-Mar-05); Type: SAM v4.0; Serial: TP-1319;
- Measurement SW: DASY4, V4.7 Build 80; Postprocessing SW: SEMCAD, V1.8 Build 186

Daily SPC Check/Dipole Area Scan (4x9x1): Measurement grid: dx=15mm, dy=15mm

Maximum value of SAR (measured) = 11.6 mW/g

Daily SPC Check/0-Degree 5x5x7 Cube (5x5x7)/Cube 0: Measurement grid: dx=8mm, dy=8mm, dz=5mm

Reference Value = 68.0 V/m; Power Drift = 0.054 dB

Peak SAR (extrapolated) = 22.1 W/kg

SAR(1 g) = 10.5 mW/g; SAR(10 g) = 4.85 mW/g

Daily SPC Check/Z-Axis Retraction (1x1x31): Measurement grid: dx=20mm, dy=20mm, dz=5mm

Maximum value of SAR (measured) = 11.8 mW/g

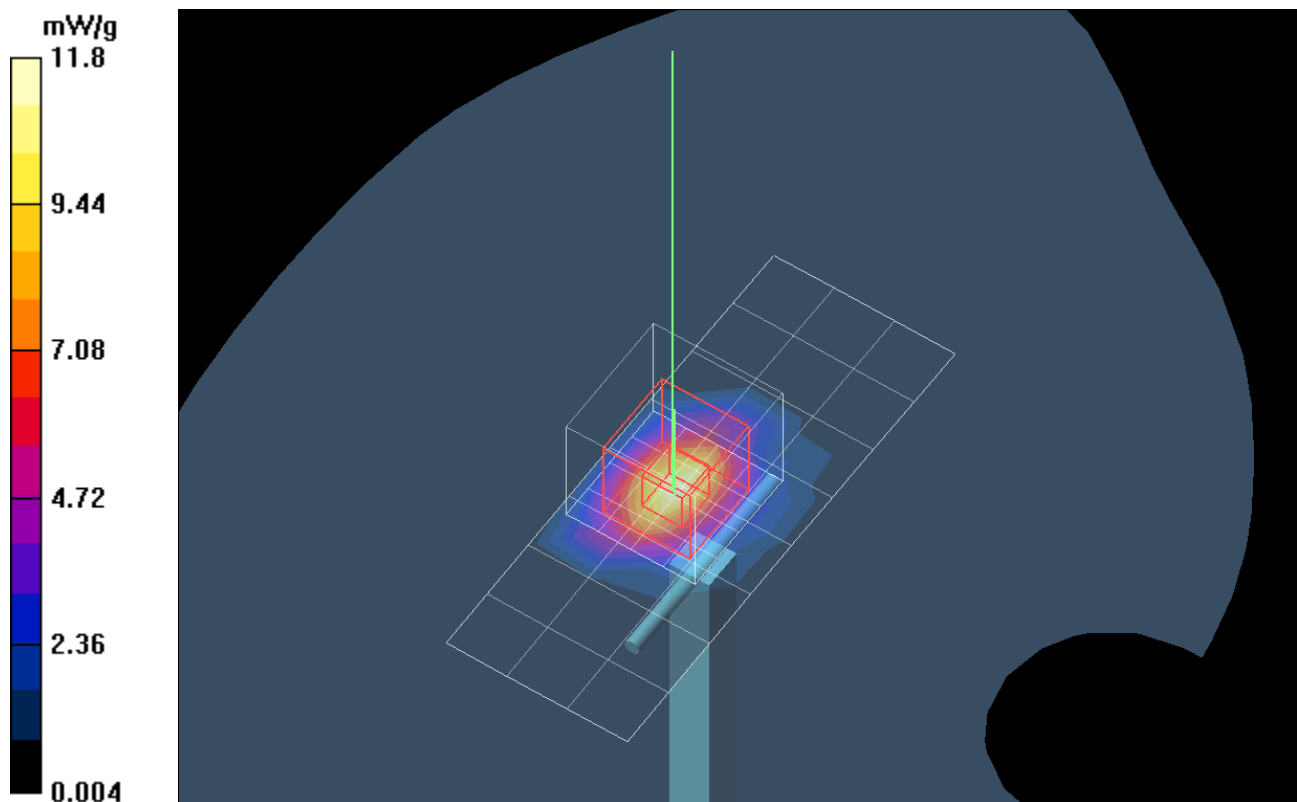

SAR(x,y,z,f0)

SAR; Z-Axis Retraction: Value Along Z, X=0, Y=0

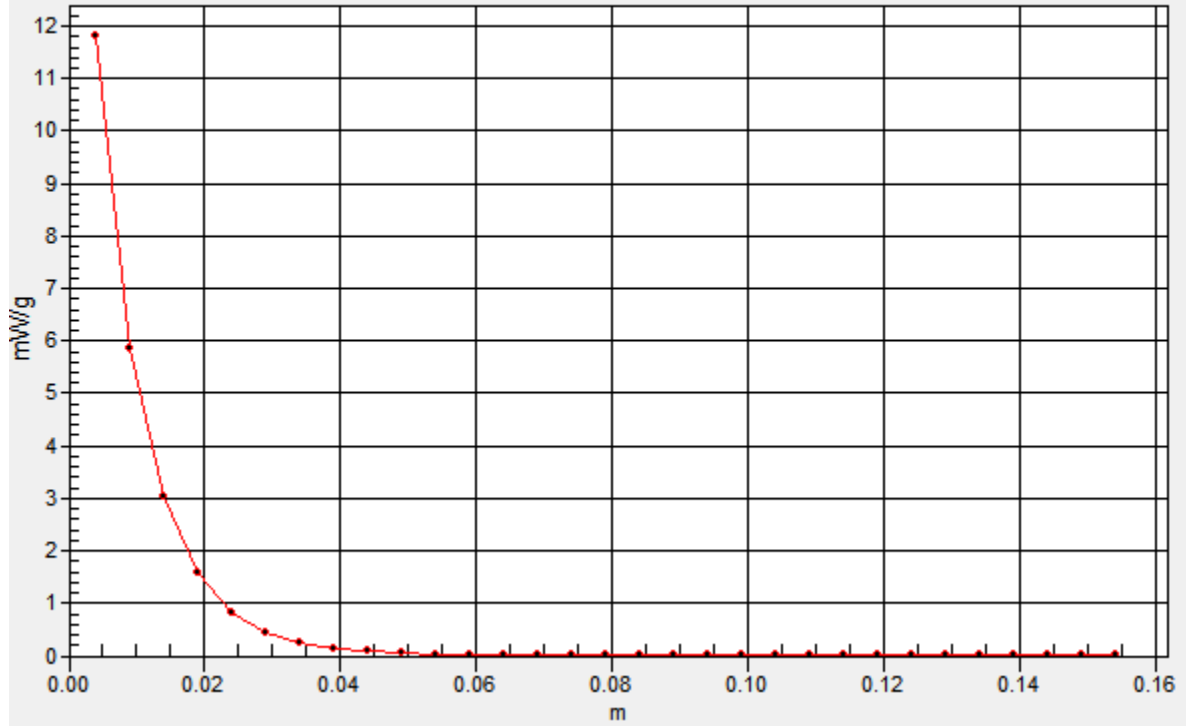

Appendix 2

SAR distribution plots for Phantom Head Adjacent Use

Test Laboratory: Motorola Mobility GSM 1900 Cheek Touch

DUT: Serial: 356472040000268, FCC ID: IHDP56MA2

Procedure Notes: Pwr Step: 0 Battery Model #: SNN5891A Test Configuration: Cheek Touch

Communication System: GSM 1900; Frequency: 1880 MHz; Duty Cycle: 1:8.3

Medium: Regular Glycol Head 1750/1880; Medium parameters used: $f = 1880$ MHz; $\sigma = 1.46$ mho/m; $\epsilon_r = 38.3$; $\rho = 1000$ kg/m³

DASY4 Configuration:

- Probe: ES3DV3 - SN3184; ConvF(5.11, 5.11, 5.11); Calibrated: 3/11/2011
- Sensor-Surface: 4mm (Mechanical Surface Detection)
- Electronics: DAE4 Sn702; Calibrated: 4/14/2011
- Phantom: R#2 Glycol SAM (extended range), Rev.1 (25-Mar-05); Type: SAM v4.0; Serial: TP-1136;
- Measurement SW: DASY4, V4.7 Build 80; Postprocessing SW: SEMCAD, V1.8 Build 186

Left Head Template/Area Scan - Normal Extended (15mm) (7x17x1): Measurement grid: dx=15mm, dy=15mm

Maximum value of SAR (measured) = 0.462 mW/g

Left Head Template/5x5x7 Zoom Scan (<=3GHz) - to correct max outside (5x5x7)/Cube 0:

Measurement grid: dx=8mm, dy=8mm, dz=5mm

Reference Value = 17.0 V/m; Power Drift = -0.104 dB

Peak SAR (extrapolated) = 0.748 W/kg

SAR(1 g) = 0.459 mW/g; SAR(10 g) = 0.276 mW/g

Maximum value of SAR (measured) = 0.504 mW/g

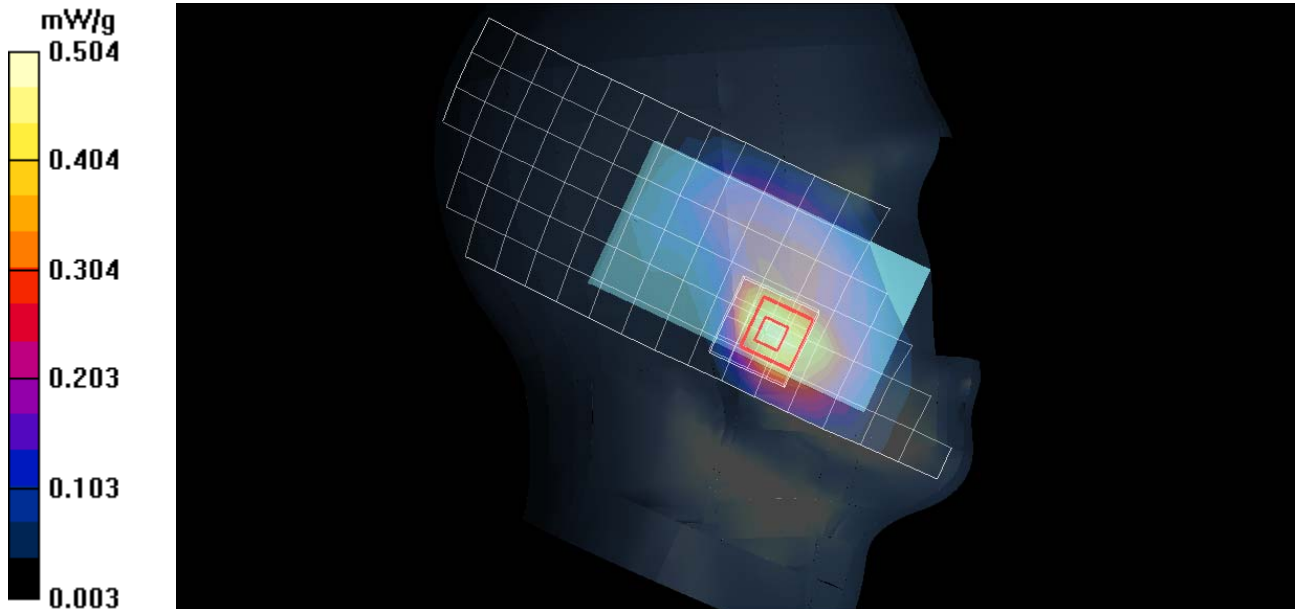

Test Laboratory: Motorola Mobility WCDMA 1900 Cheek Touch

DUT: Serial: 356472040000268, FCC ID: IHDP56MA2

Procedure Notes: Pwr Step: ALL UP BITS Battery Model #: SNN5891A Test Configuration: CHEEK Touch

Communication System: 3G/WCDMA 1900; Frequency: 1880 MHz; Duty Cycle: 1:1

Medium: Regular Glycol Head 1750/1880; Medium parameters used: $f = 1880$ MHz; $\sigma = 1.47$ mho/m; $\epsilon_r = 38.2$; $\rho = 1000$ kg/m³

DASY4 Configuration:

- Probe: ES3DV3 - SN3184; ConvF(5.11, 5.11, 5.11); Calibrated: 3/11/2011
- Sensor-Surface: 4mm (Mechanical Surface Detection)
- Electronics: DAE4 Sn702; Calibrated: 4/14/2011
- Phantom: R#2 Glycol SAM (extended range), Rev.1 (25-Mar-05); Type: SAM v4.0; Serial: TP-1136;
- Measurement SW: DASY4, V4.7 Build 80; Postprocessing SW: SEMCAD, V1.8 Build 186

Left Head Template/Area Scan - Normal (15mm) (7x17x1): Measurement grid: dx=15mm, dy=15mm

Maximum value of SAR (measured) = 0.859 mW/g

Left Head Template/5x5x7 Zoom Scan (<=3GHz) (5x5x7)/Cube 0: Measurement grid: dx=8mm, dy=8mm, dz=5mm

Reference Value = 22.7 V/m; Power Drift = -0.039 dB

Peak SAR (extrapolated) = 1.44 W/kg

SAR(1 g) = 0.892 mW/g; SAR(10 g) = 0.535 mW/g

Maximum value of SAR (measured) = 0.958 mW/g

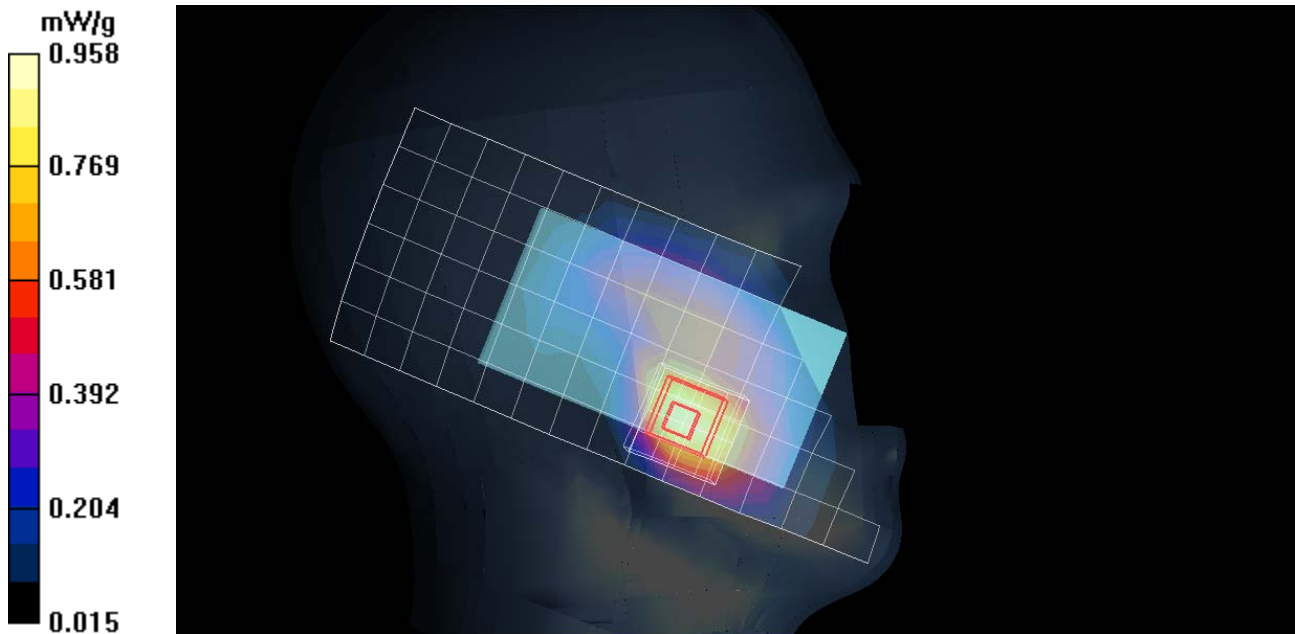

Test Laboratory: Motorola Mobility WCDMA 850 Cheek Touch

DUT: Serial: 356472040000268, FCC ID: IHDP56MA2

Procedure Notes: Pwr Step: ALL UP BITS Battery Model #: SNN5891A Test Configuration: CHEEK

Communication System: 3G-WCDMA 850; Frequency: 836 MHz; Duty Cycle: 1:1

Medium: Low Freq Head; Medium parameters used: $f = 835$ MHz; $\sigma = 0.92$ mho/m; $\epsilon_r = 41.9$; $\rho = 1000$ kg/m³

DASY4 Configuration:

- Probe: ES3DV3 - SN3184; ConvF(6.11, 6.11, 6.11); Calibrated: 3/11/2011
- Sensor-Surface: 4mm (Mechanical Surface Detection)
- Electronics: DAE4 Sn702; Calibrated: 4/14/2011
- Phantom: R#2_Sugar SAM (extended range), Rev.1 (25-Mar-05); Type: SAM v4.0; Serial: TP-1235;
- Measurement SW: DASY4, V4.7 Build 80; Postprocessing SW: SEMCAD, V1.8 Build 186

Right Head Template/Area Scan - Normal (15mm) (7x17x1): Measurement grid: dx=15mm, dy=15mm

Maximum value of SAR (measured) = 0.383 mW/g

Right Head Template/5x5x7 Zoom Scan (<=3GHz) (5x5x7)/Cube 0: Measurement grid: dx=8mm, dy=8mm, dz=5mm

Reference Value = 20.4 V/m; Power Drift = -0.025 dB

Peak SAR (extrapolated) = 0.456 W/kg

SAR(1 g) = 0.370 mW/g; SAR(10 g) = 0.281 mW/g

Maximum value of SAR (measured) = 0.387 mW/g

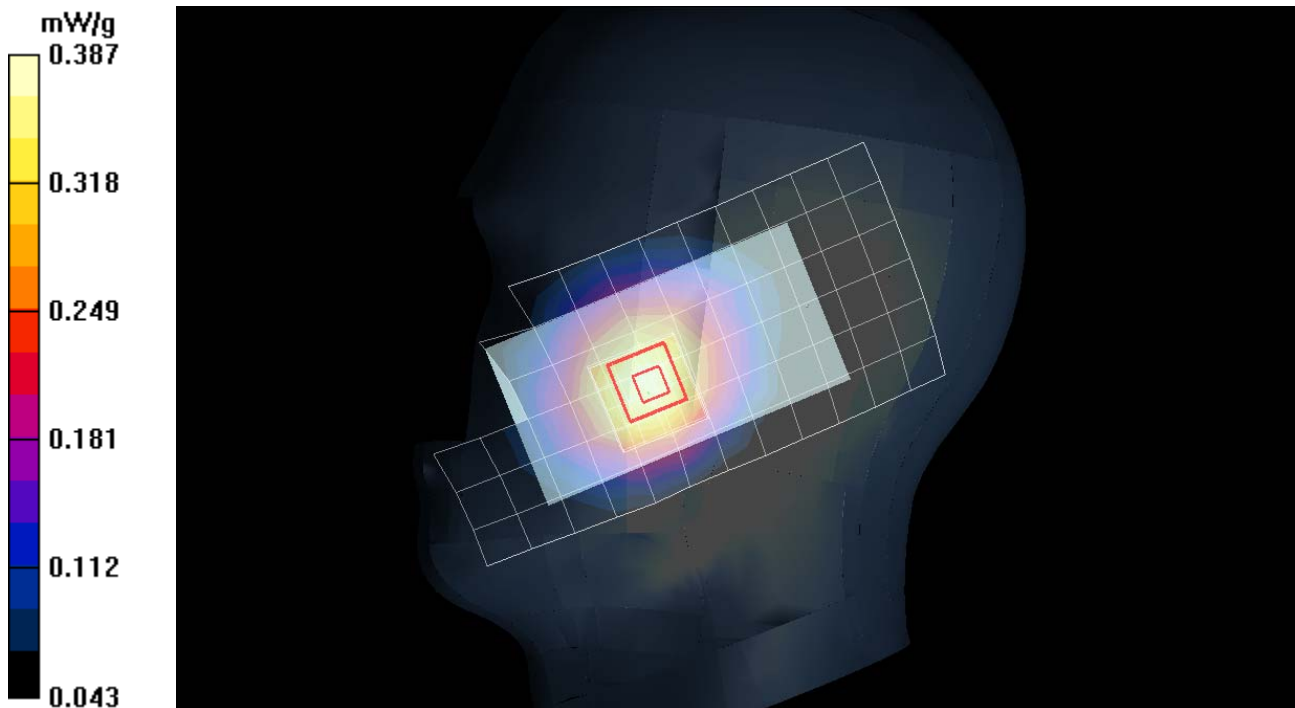

Test Laboratory: Motorola Mobility GSM 850 Cheek Touch

DUT: Serial: 356472040000268, FCC ID: IHDP56A2

Procedure Notes: Pwr Step: 5 Battery Model #: SNN5891A Test Configuration: CHEEK Touch

Communication System: GSM 850; Frequency: 836.6 MHz; Duty Cycle: 1:8.3

Medium: Low Freq Head; Medium parameters used: $f = 835 \text{ MHz}$; $\sigma = 0.92 \text{ mho/m}$; $\epsilon_r = 41.9$; $\rho = 1000 \text{ kg/m}^3$

DASY4 Configuration:

- Probe: ES3DV3 - SN3184; ConvF(6.11, 6.11, 6.11); Calibrated: 3/11/2011
- Sensor-Surface: 4mm (Mechanical Surface Detection)
- Electronics: DAE4 Sn702; Calibrated: 4/14/2011
- Phantom: R#2_Sugar SAM (extended range), Rev.1 (25-Mar-05); Type: SAM v4.0; Serial: TP-1235;
- Measurement SW: DASY4, V4.7 Build 80; Postprocessing SW: SEMCAD, V1.8 Build 186

Right Head Template/Area Scan - Normal (15mm) (7x17x1): Measurement grid: $dx=15\text{mm}$, $dy=15\text{mm}$

Maximum value of SAR (measured) = 0.375 mW/g

Right Head Template/5x5x7 Zoom Scan (<=3GHz) (5x5x7)/Cube 0: Measurement grid: $dx=8\text{mm}$,

$dy=8\text{mm}$, $dz=5\text{mm}$

Reference Value = 20.7 V/m; Power Drift = -0.030 dB

Peak SAR (extrapolated) = 0.468 W/kg

SAR(1 g) = 0.370 mW/g; SAR(10 g) = 0.279 mW/g

Maximum value of SAR (measured) = 0.390 mW/g

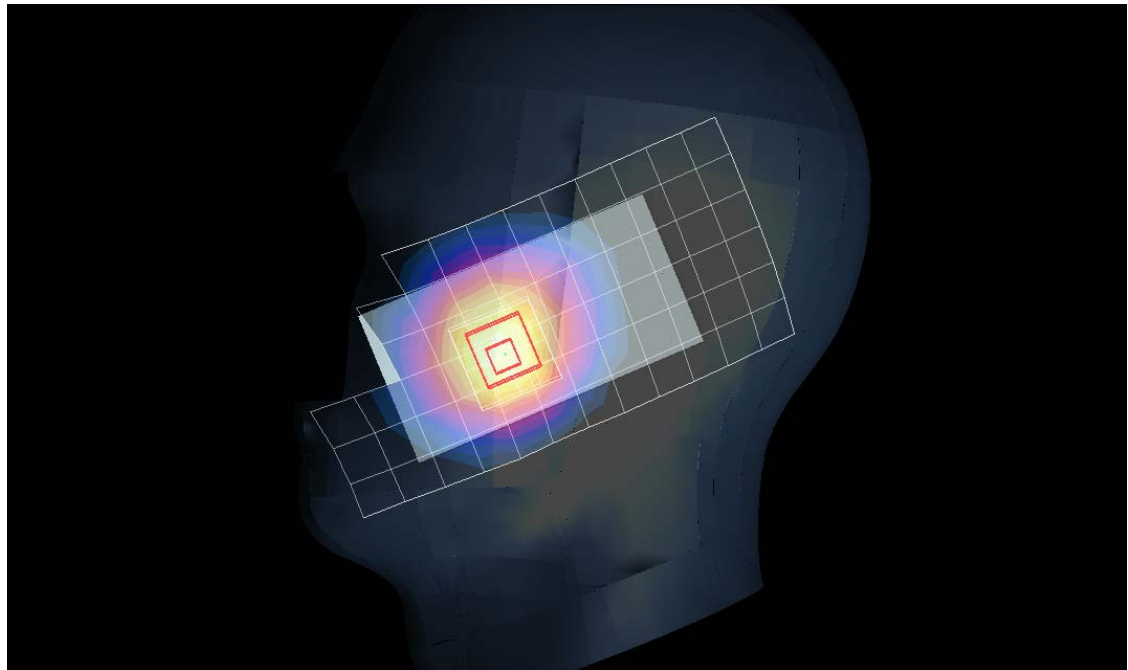
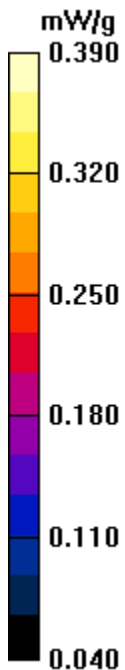

Test Laboratory: Motorola Mobility WCDMA 1900 15 Degree tilt

DUT: Serial: 356472040000268, FCC ID: IHDP56MA2

Procedure Notes: Pwr Step: ALL UP BITS Battery Model #: SNN5891A Test Configuration: 15 Degree TILT

Communication System: 3G/WCDMA 1900; Frequency: 1880 MHz; Duty Cycle: 1:1

Medium: Regular Glycol Head 1750/1880; Medium parameters used: $f = 1880$ MHz; $\sigma = 1.47$ mho/m; $\epsilon_r = 38.2$; $\rho = 1000$ kg/m³

DASY4 Configuration:

- Probe: ES3DV3 - SN3184; ConvF(5.11, 5.11, 5.11); Calibrated: 3/11/2011
- Sensor-Surface: 4mm (Mechanical Surface Detection)
- Electronics: DAE4 Sn702; Calibrated: 4/14/2011
- Phantom: R#2 Glycol SAM (extended range), Rev.1 (25-Mar-05); Type: SAM v4.0; Serial: TP-1136;
- Measurement SW: DASY4, V4.7 Build 80; Postprocessing SW: SEMCAD, V1.8 Build 186

Left Head Template/Area Scan - Normal (15mm) (7x17x1): Measurement grid: dx=15mm, dy=15mm

Maximum value of SAR (measured) = 0.377 mW/g

Left Head Template/5x5x7 Zoom Scan (<=3GHz) (5x5x7)/Cube 0: Measurement grid: dx=8mm, dy=8mm, dz=5mm

Reference Value = 16.2 V/m; Power Drift = -0.025 dB

Peak SAR (extrapolated) = 0.561 W/kg

SAR(1 g) = 0.360 mW/g; SAR(10 g) = 0.227 mW/g

Maximum value of SAR (measured) = 0.376 mW/g

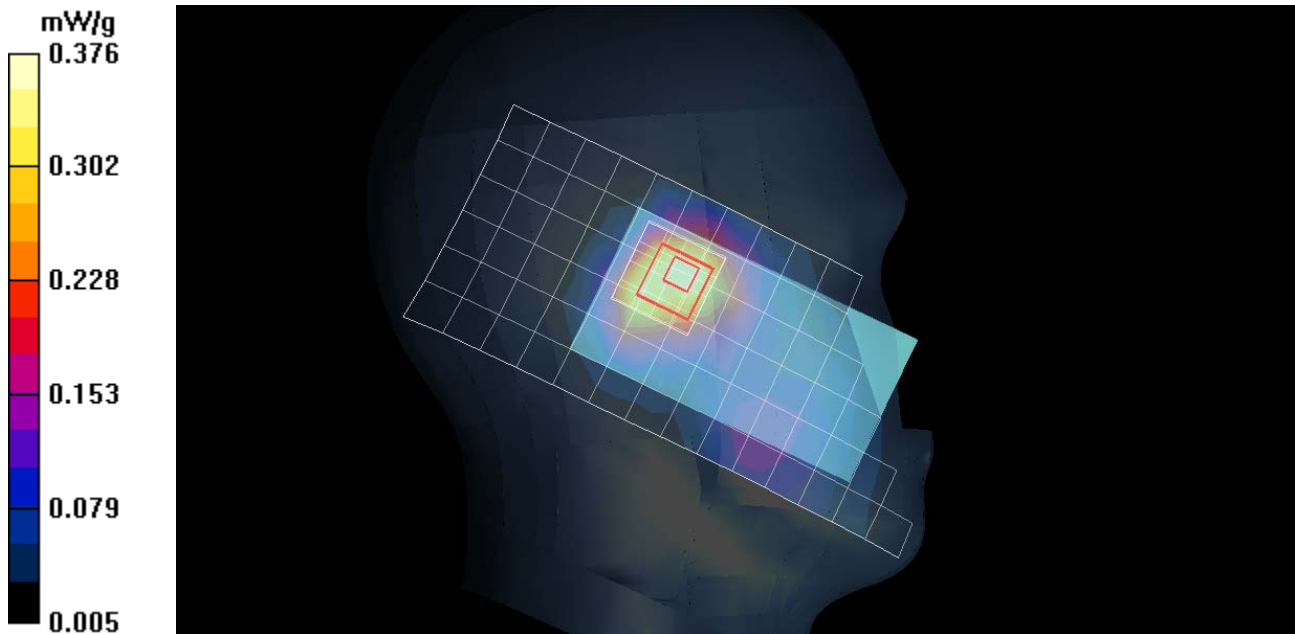

Test Laboratory: Motorola Mobility GSM 1900 15 Degree Tilt

DUT: Serial: 356472040000268, FCC ID: IHDP56MA2

Procedure Notes: Pwr Step: 0 Battery Model #: SNN5891A Test Configuration: 15 Degree Tilt

Communication System: GSM 1900; Frequency: 1880 MHz; Duty Cycle: 1:8.3

Medium: Regular Glycol Head 1750/1880; Medium parameters used: $f = 1880$ MHz; $\sigma = 1.46$ mho/m; $\epsilon_r = 38.3$; $\rho = 1000$ kg/m³

DASY4 Configuration:

- Probe: ES3DV3 - SN3184; ConvF(5.11, 5.11, 5.11); Calibrated: 3/11/2011
- Sensor-Surface: 4mm (Mechanical Surface Detection)
- Electronics: DAE4 Sn702; Calibrated: 4/14/2011
- Phantom: R#2 Glycol SAM (extended range), Rev.1 (25-Mar-05); Type: SAM v4.0; Serial: TP-1136;
- Measurement SW: DASY4, V4.7 Build 80; Postprocessing SW: SEMCAD, V1.8 Build 186

Left Head Template/Area Scan - Normal Extended (10mm) (10x25x1): Measurement grid: dx=10mm, dy=10mm

Maximum value of SAR (measured) = 0.190 mW/g

Left Head Template/5x5x7 Zoom Scan (<=3GHz) - to correct max outside (5x5x7)/Cube 0:

Measurement grid: dx=8mm, dy=8mm, dz=5mm

Reference Value = 11.1 V/m; Power Drift = -0.220 dB

Peak SAR (extrapolated) = 0.269 W/kg

SAR(1 g) = 0.176 mW/g; SAR(10 g) = 0.104 mW/g

Maximum value of SAR (measured) = 0.192 mW/g

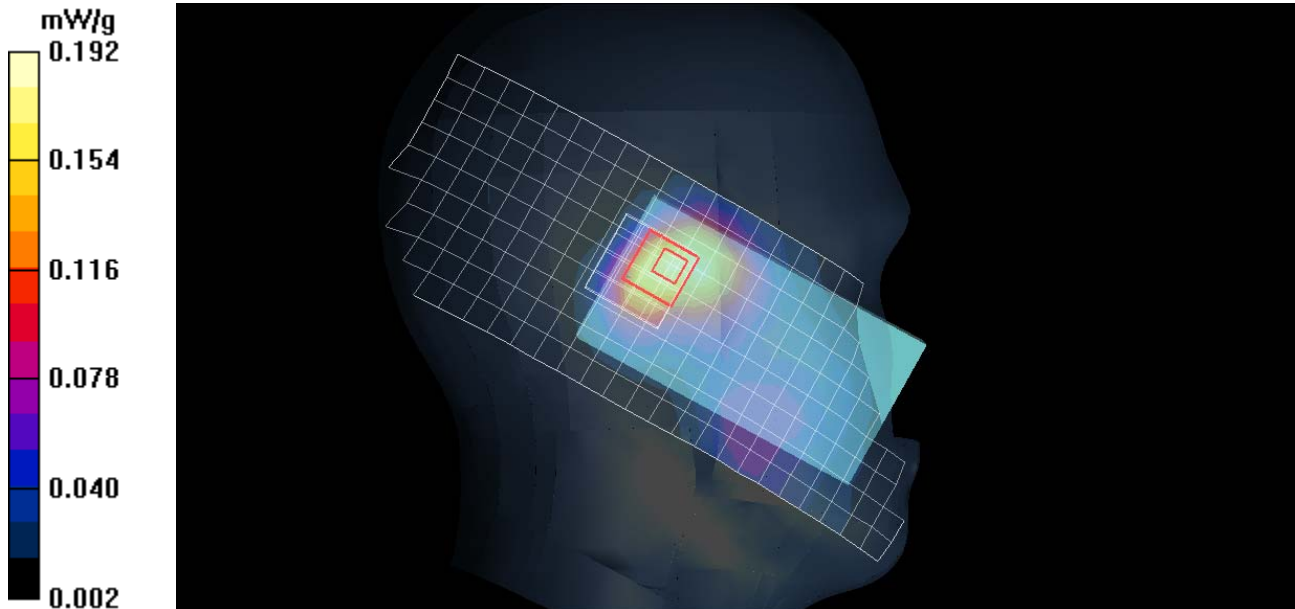

Test Laboratory: Motorola Mobility WCDMA 850 15 Degree Tilt

DUT: Serial: 356472040000268, FCC ID: IHDP56MA2

Procedure Notes: Pwr Step: ALL UP BITS Battery Model #: SNN5891A Test Configuration: 15 Degree TILT
Communication System: 3G-WCDMA 850; Frequency: 836 MHz; Duty Cycle: 1:1

Medium: Low Freq Head; Medium parameters used: $f = 835$ MHz; $\sigma = 0.92$ mho/m; $\epsilon_r = 41.9$; $\rho = 1000$ kg/m³

DASY4 Configuration:

- Probe: ES3DV3 - SN3184; ConvF(6.11, 6.11, 6.11); Calibrated: 3/11/2011
- Sensor-Surface: 4mm (Mechanical Surface Detection)
- Electronics: DAE4 Sn702; Calibrated: 4/14/2011
- Phantom: R#2_Sugar SAM (extended range), Rev.1 (25-Mar-05); Type: SAM v4.0; Serial: TP-1235;
- Measurement SW: DASY4, V4.7 Build 80; Postprocessing SW: SEMCAD, V1.8 Build 186

Right Head Template/Area Scan - Normal (15mm) (7x17x1): Measurement grid: dx=15mm, dy=15mm
Maximum value of SAR (measured) = 0.238 mW/g

Right Head Template/5x5x7 Zoom Scan (<=3GHz) (5x5x7)/Cube 0: Measurement grid: dx=8mm, dy=8mm, dz=5mm

Reference Value = 15.7 V/m; Power Drift = 0.086 dB

Peak SAR (extrapolated) = 0.294 W/kg

SAR(1 g) = 0.237 mW/g; SAR(10 g) = 0.180 mW/g

Maximum value of SAR (measured) = 0.250 mW/g

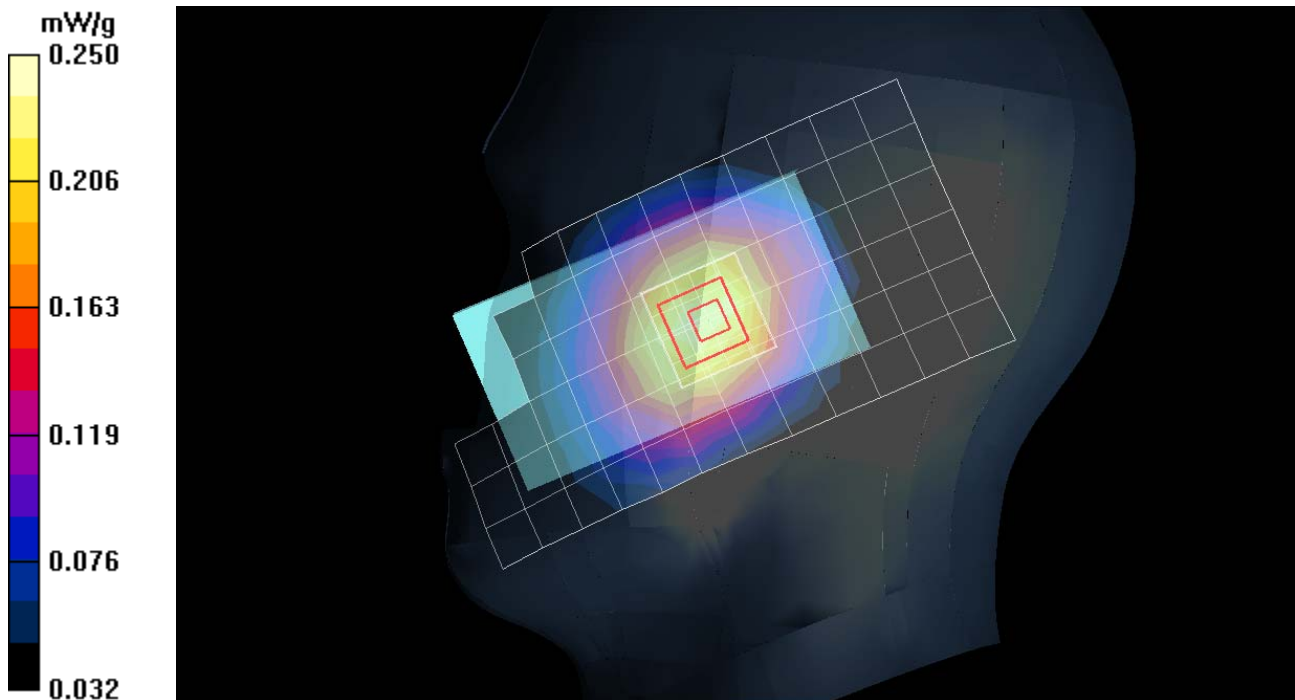

Test Laboratory: Motorola Mobility GSM 850 15 Degree Tilt

DUT: Serial: 356472040000268, FCC ID: IHDP56MA2

Procedure Notes: Pwr Step: 5 Battery Model #: SNN5891A Test Configuration: 15 Degree TILT

Communication System: GSM 850; Frequency: 836.6 MHz; Duty Cycle: 1:8.3

Medium: Low Freq Head; Medium parameters used: $f = 835$ MHz; $\sigma = 0.92$ mho/m; $\epsilon_r = 41.9$; $\rho = 1000$ kg/m³

DASY4 Configuration:

- Probe: ES3DV3 - SN3184; ConvF(6.11, 6.11, 6.11); Calibrated: 3/11/2011
- Sensor-Surface: 4mm (Mechanical Surface Detection)
- Electronics: DAE4 Sn702; Calibrated: 4/14/2011
- Phantom: R#2_ Sugar SAM (extended range), Rev.1 (25-Mar-05); Type: SAM v4.0; Serial: TP-1235;
- Measurement SW: DASY4, V4.7 Build 80; Postprocessing SW: SEMCAD, V1.8 Build 186

Right Head Template/Area Scan - Normal (15mm) (7x17x1): Measurement grid: dx=15mm, dy=15mm

Maximum value of SAR (measured) = 0.238 mW/g

Right Head Template/5x5x7 Zoom Scan (<=3GHz) (5x5x7)/Cube 0: Measurement grid: dx=8mm,

dy=8mm, dz=5mm

Reference Value = 15.8 V/m; Power Drift = -0.101 dB

Peak SAR (extrapolated) = 0.284 W/kg

SAR(1 g) = 0.232 mW/g; SAR(10 g) = 0.177 mW/g

Maximum value of SAR (measured) = 0.241 mW/g

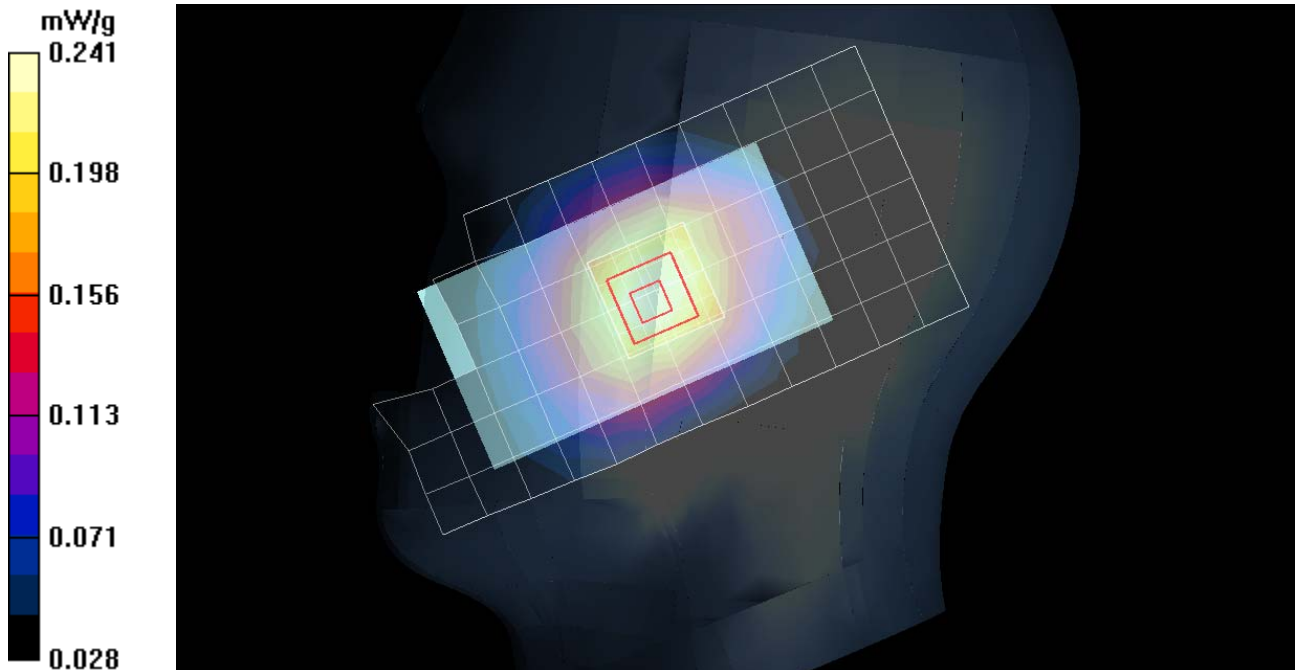

Test Laboratory: Motorola Mobility WCDMA 850 Cheek Touch

DUT: Serial: 356472040000268, FCC ID: IHDP56MA2

Procedure Notes: Pwr Step: ALL UP BITS Battery Model #: SNN5891A Test Configuration: CHEEK

Communication System: 3G-WCDMA 850; Frequency: 836 MHz; Duty Cycle: 1:1

Medium: Low Freq Head; Medium parameters used: $f = 835$ MHz; $\sigma = 0.92$ mho/m; $\epsilon_r = 41.9$; $\rho = 1000$ kg/m³

DASY4 Configuration:

- Probe: ES3DV3 - SN3184; ConvF(6.11, 6.11, 6.11); Calibrated: 3/11/2011
- Sensor-Surface: 4mm (Mechanical Surface Detection)
- Electronics: DAE4 Sn702; Calibrated: 4/14/2011
- Phantom: R#2_Sugar SAM (extended range), Rev.1 (25-Mar-05); Type: SAM v4.0; Serial: TP-1235;
- Measurement SW: DASY4, V4.7 Build 80; Postprocessing SW: SEMCAD, V1.8 Build 186

Right Head Template/Area Scan - Normal (15mm) (7x17x1): Measurement grid: dx=15mm, dy=15mm

Maximum value of SAR (measured) = 0.383 mW/g

Right Head Template/5x5x7 Zoom Scan (<=3GHz) (5x5x7)/Cube 0: Measurement grid: dx=8mm, dy=8mm, dz=5mm

Reference Value = 20.4 V/m; Power Drift = -0.025 dB

Peak SAR (extrapolated) = 0.456 W/kg

SAR(1 g) = 0.370 mW/g; SAR(10 g) = 0.281 mW/g

Maximum value of SAR (measured) = 0.387 mW/g

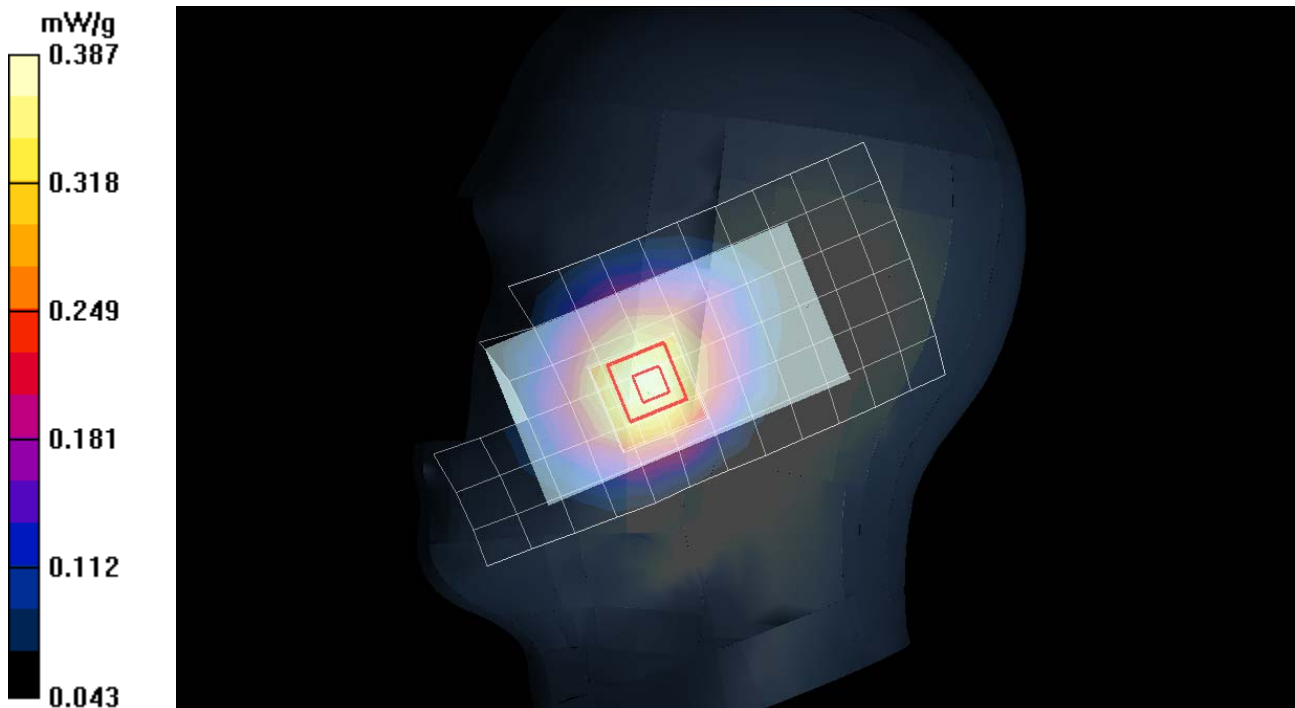

Test Laboratory: Motorola WiFi 2450MHz 15 Degree Tilt

DUT: Serial: '356472040014939, FCC ID: IHDP56MA2

Procedure Notes: 802.11b 1Mbps Battery Model #: SNN5891A DEVICE POSITION: 15 Degree Tilt

Communication System: Wi-Fi 2450; Frequency: 2437 MHz; Duty Cycle: 1:1

Medium: 2450 Glycol Head; Medium parameters used: $f = 2450$ MHz; $\sigma = 1.85$ mho/m; $\epsilon_r = 36.3$; $\rho = 1000$ kg/m³

DASY4 Configuration:

- Probe: ES3DV3 - SN3115; ConvF(4.39, 4.39, 4.39); Calibrated: 1/12/2011
- Sensor-Surface: 4mm (Mechanical Surface Detection)
- Electronics: DAE3 Sn434; Calibrated: 1/13/2011
- Phantom: R#4 Glycol SAM (extended range), Rev.1 (25-Mar-05); Type: SAM v4.0; Serial: TP-1318;
- Measurement SW: DASY4, V4.7 Build 80; Postprocessing SW: SEMCAD, V1.8 Build 186

Right Head Template/Area Scan - Normal (15mm) (7x17x1): Measurement grid: dx=15mm, dy=15mm

Maximum value of SAR (measured) = 0.131 mW/g

Right Head Template/5x5x7 Zoom Scan (<=3GHz) - to correct max outside (5x5x7)/Cube 0:

Measurement grid: dx=8mm, dy=8mm, dz=5mm

Reference Value = 6.61 V/m; Power Drift = 0.031 dB

Peak SAR (extrapolated) = 0.206 W/kg

SAR(1 g) = 0.083 mW/g; SAR(10 g) = 0.035 mW/g

Maximum value of SAR (measured) = 0.191 mW/g

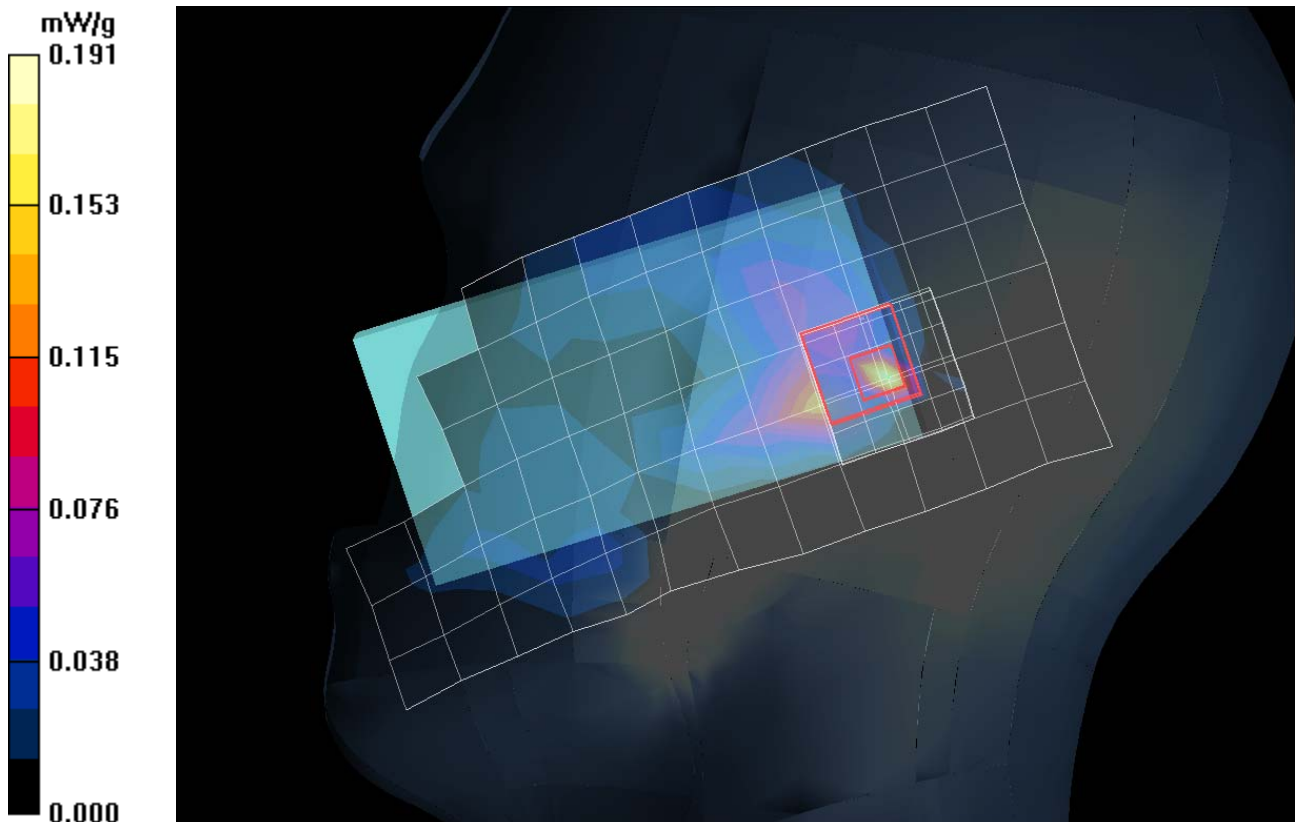

Appendix 3

SAR distribution plots for Body Worn Configuration

Test Laboratory: Motorola Mobility GSM 850 Body Worn

DUT: Serial: 356472040000268, FCC ID: IHDP56MA2

Procedure Notes: Pwr Step: 5 Battery Model #: SNN5891A Test Configuration = Back of Phone 15mm Phantom
Communication System: GSM 850; Frequency: 836.6 MHz; Duty Cycle: 1:8.3

Medium: Low Freq Body; Medium parameters used: $f = 835 \text{ MHz}$; $\sigma = 0.98 \text{ mho/m}$; $\epsilon_r = 55.1$; $\rho = 1000 \text{ kg/m}^3$

DASY4 Configuration:

- Probe: ES3DV3 - SN3184; ConvF(6.1, 6.1, 6.1); Calibrated: 3/11/2011
- Sensor-Surface: 4mm (Mechanical Surface Detection)
- Electronics: DAE4 Sn702; Calibrated: 4/14/2011
- Phantom: R#2_ Section 2, Amy Twin, Rev3 (3-Feb-10); Type: Amy Twin Flat; Serial: n/a;
- Measurement SW: DASY4, V4.7 Build 80; Postprocessing SW: SEMCAD, V1.8 Build 186

Amy Twin Phone Template/Area Scan - Full Body (15mm) (18x8x1): Measurement grid: $dx=15\text{mm}$, $dy=15\text{mm}$

Maximum value of SAR (measured) = 0.544 mW/g

Amy Twin Phone Template/5x5x7 Zoom Scan ($\leq 3\text{GHz}$) (5x5x7)/Cube 0: Measurement grid: $dx=8\text{mm}$, $dy=8\text{mm}$, $dz=5\text{mm}$

Reference Value = 23.6 V/m; Power Drift = -0.175 dB

Peak SAR (extrapolated) = 0.698 W/kg

SAR(1 g) = 0.522 mW/g; SAR(10 g) = 0.377 mW/g

Maximum value of SAR (measured) = 0.554 mW/g

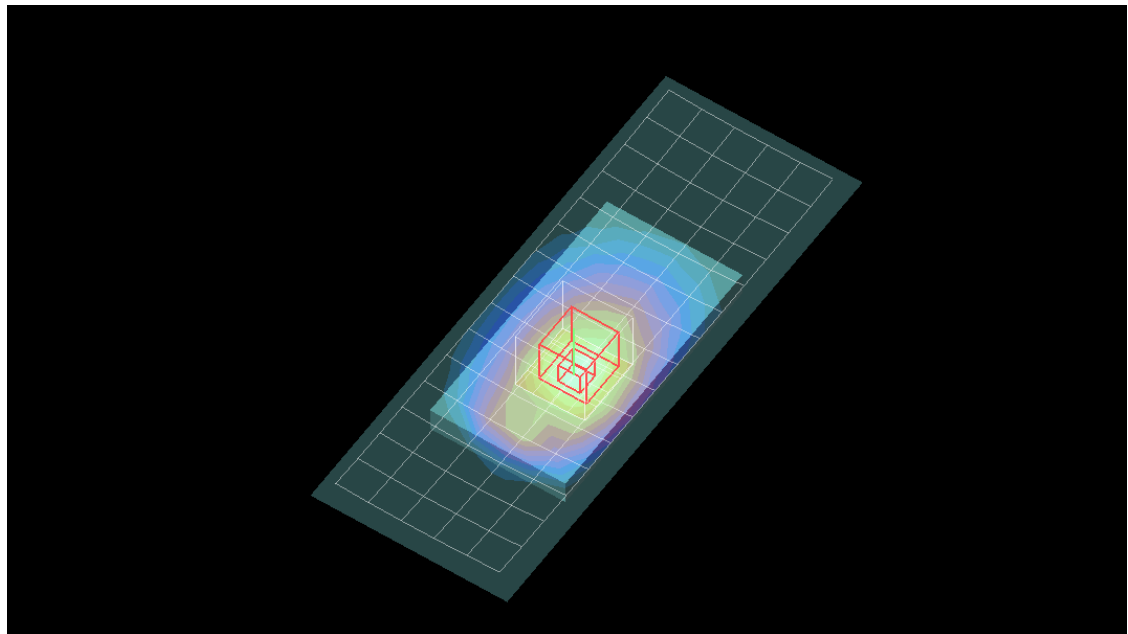
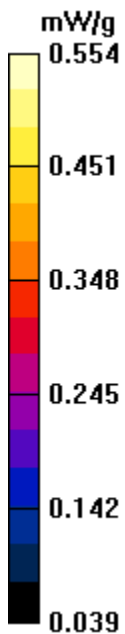

Test Laboratory: Motorola Mobility WCDMA 850 Body Worn

DUT: Serial: 356472040000268, FCC ID: IHDP56MA2

Procedure Notes: Pwr Step:always up Battery Model #: SNN5891A Test Configuration = BACK OF PHONE
15MM FROM PHANTOM

Communication System: 3G-WCDMA 850; Frequency: 836 MHz;Duty Cycle: 1:1

Medium: Low Freq Body; Medium parameters used: $f = 835$ MHz; $\sigma = 0.98$ mho/m; $\epsilon_r = 54.4$; $\rho = 1000$ kg/m³

DASY4 Configuration:

- Probe: ES3DV3 - SN3184; ConvF(6.1, 6.1, 6.1); Calibrated: 3/11/2011
- Sensor-Surface: 4mm (Mechanical Surface Detection)
- Electronics: DAE4 Sn702; Calibrated: 4/14/2011
- Phantom: R#2_ Section 2, Amy Twin, Rev3 (3-Feb-10); Type: Amy Twin Flat; Serial: n/a;
- Measurement SW: DASY4, V4.7 Build 80; Postprocessing SW: SEMCAD, V1.8 Build 186

Amy Twin Phone Template/Area Scan - Normal Extended Body (15mm) (16x7x1): Measurement grid:

$dx=15$ mm, $dy=15$ mm

Maximum value of SAR (measured) = 0.774 mW/g

Amy Twin Phone Template/5x5x7 Zoom Scan (≤ 3 GHz) (5x5x7)/Cube 0: Measurement grid: $dx=8$ mm,

$dy=8$ mm, $dz=5$ mm

Reference Value = 28.4 V/m; Power Drift = -0.225 dB

Peak SAR (extrapolated) = 0.952 W/kg

SAR(1 g) = 0.716 mW/g; SAR(10 g) = 0.518 mW/g

Maximum value of SAR (measured) = 0.753 mW/g

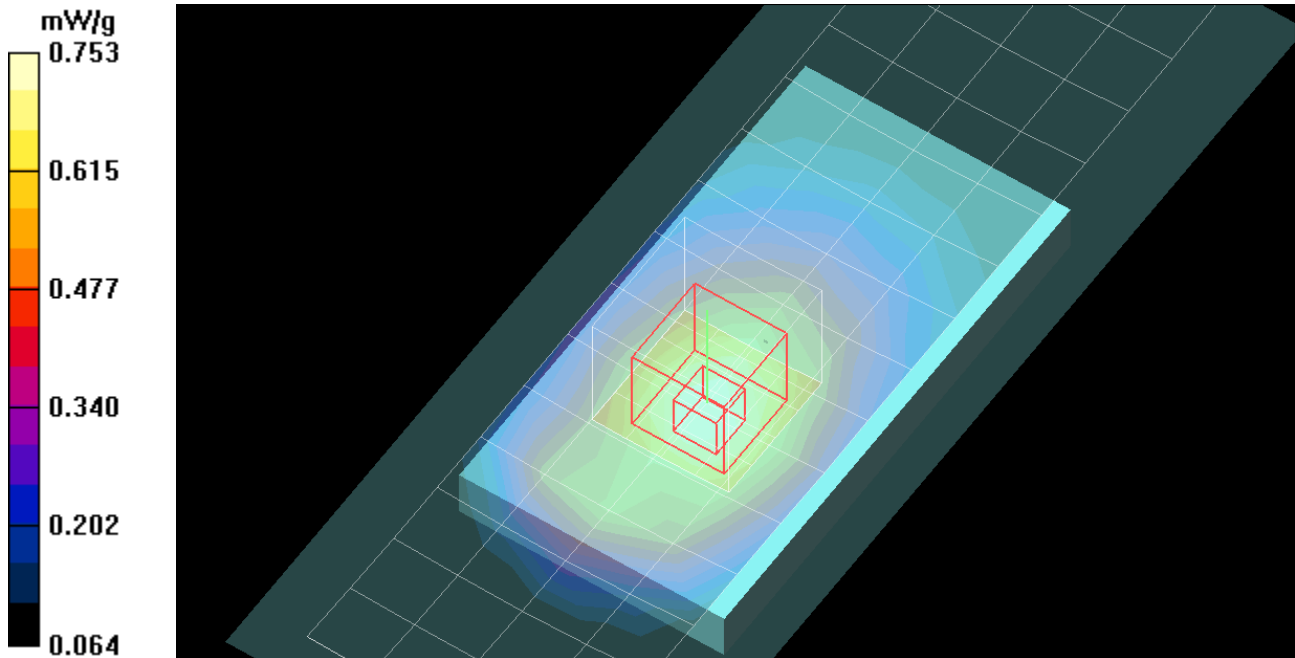

Test Laboratory: Motorola Mobility GSM1900 BodyWorn

DUT: Serial: 356472040000268, FCC ID:IHDP56MA2

Procedure Notes: Pwr Step: 0 Battery Model #: SNN5891A Test Configuration = Back of Phone 15mm from Phantom
Communication System: GSM 1900; Frequency: 1880 MHz; Duty Cycle: 1:8.3

Medium: Regular Glycol Body 1750/1880; Medium parameters used: $f = 1880$ MHz; $\sigma = 1.58$ mho/m; $\epsilon_r = 50.9$; $\rho = 1000$ kg/m³

DASY4 Configuration:

- Probe: ES3DV3 - SN3184; ConvF(4.9, 4.9, 4.9); Calibrated: 3/11/2011
- Sensor-Surface: 4mm (Mechanical Surface Detection)
- Electronics: DAE4 Sn702; Calibrated: 4/14/2011
- Phantom: R#2_ Section 1, Amy Twin, Rev3 (3-Feb-10); Type: Amy Twin Flat; Serial: n/a;
- Measurement SW: DASY4, V4.7 Build 80; Postprocessing SW: SEMCAD, V1.8 Build 186

Amy Twin Phone Template/Area Scan - Full Body (15mm) (18x8x1): Measurement grid: dx=15mm, dy=15mm

Maximum value of SAR (measured) = 0.392 mW/g

Amy Twin Phone Template/5x5x7 Zoom Scan (<=3GHz) (5x5x7)/Cube 0: Measurement grid: dx=8mm, dy=8mm, dz=5mm

Reference Value = 14.7 V/m; Power Drift = -0.025 dB

Peak SAR (extrapolated) = 0.647 W/kg

SAR(1 g) = 0.390 mW/g; SAR(10 g) = 0.235 mW/g

Maximum value of SAR (measured) = 0.410 mW/g

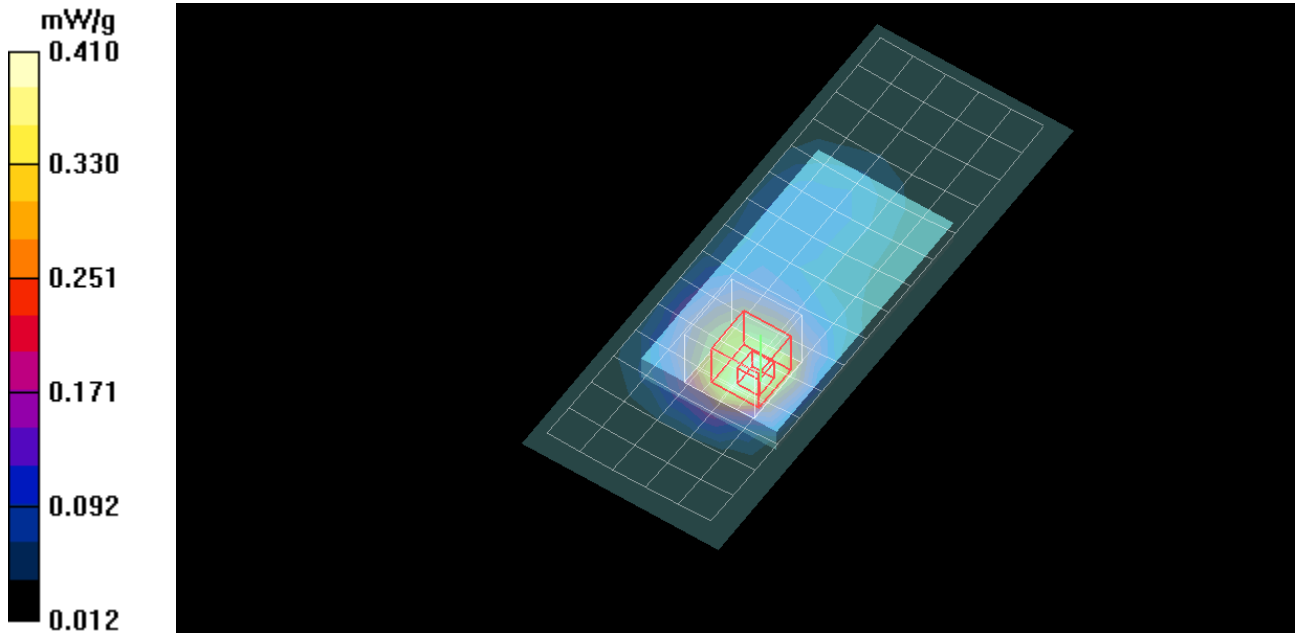

Test Laboratory: Motorola Mobility WCDMA 1900 Body Worn

DUT: Serial: 356472040000268, FCC ID: IHDP56MA2

Procedure Notes: Pwr Step: All Up Bits Battery Model #: SNN5891A Test Configuration = Back of Phone 15mm from Phantom

Communication System: 3G/WCDMA 1900; Frequency: 1880 MHz; Duty Cycle: 1:1

Medium: Regular Glycol Body 1750/1880; Medium parameters used: $f = 1880$ MHz; $\sigma = 1.57$ mho/m; $\epsilon_r = 51$; $\rho = 1000$ kg/m³

DASY4 Configuration:

- Probe: ES3DV3 - SN3184; ConvF(4.9, 4.9, 4.9); Calibrated: 3/11/2011
- Sensor-Surface: 4mm (Mechanical Surface Detection)
- Electronics: DAE4 Sn702; Calibrated: 4/14/2011
- Phantom: R#2_ Section 1, Amy Twin, Rev3 (3-Feb-10); Type: Amy Twin Flat; Serial: n/a;
- Measurement SW: DASY4, V4.7 Build 80; Postprocessing SW: SEMCAD, V1.8 Build 186

Amy Twin Phone Template/Area Scan - Full Body (15mm) (18x8x1): Measurement grid: dx=15mm, dy=15mm

Maximum value of SAR (measured) = 0.731 mW/g

Amy Twin Phone Template/5x5x7 Zoom Scan (<=3GHz) (5x5x7)/Cube 0: Measurement grid: dx=8mm, dy=8mm, dz=5mm

Reference Value = 19.7 V/m; Power Drift = -0.097 dB

Peak SAR (extrapolated) = 1.21 W/kg

SAR(1 g) = 0.739 mW/g; SAR(10 g) = 0.450 mW/g

Maximum value of SAR (measured) = 0.801 mW/g

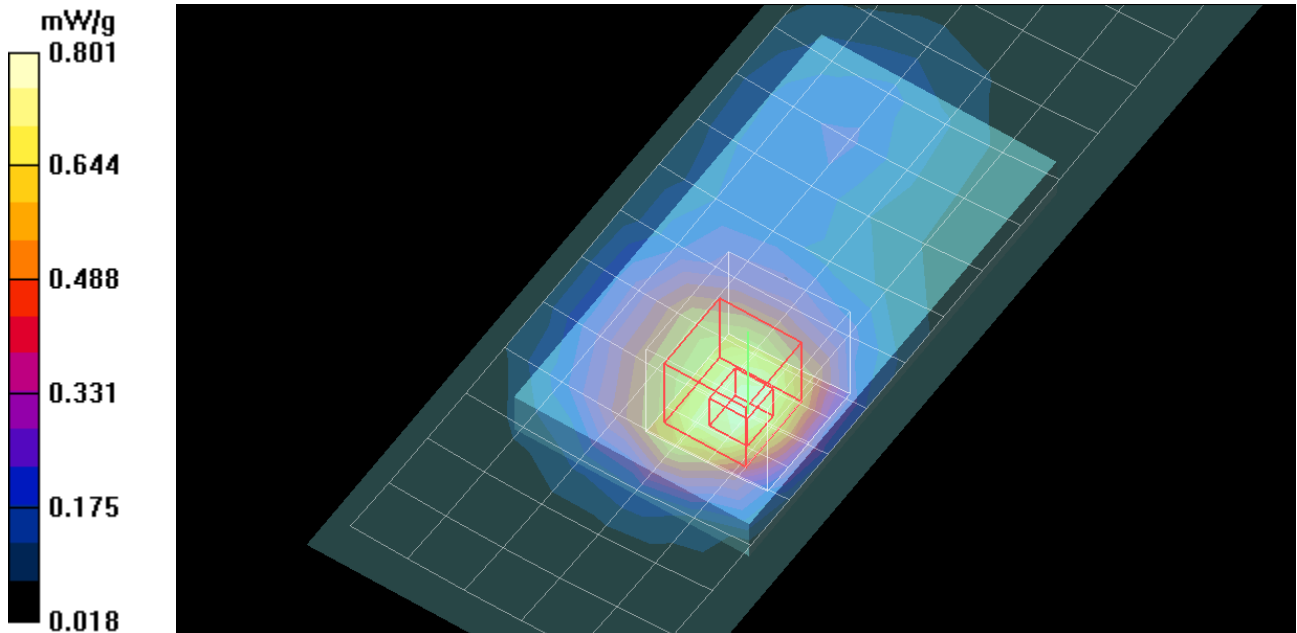

Test Laboratory: Motorola WiFi 2450MHz Body Worn

DUT: Serial: 356472040014939, FCC ID: IHDP56MA2

Procedure Notes: 802.11b 1Mbps Battery Model #: SNN5891A Test Configuration: BODY WORN, BACK OF PHONE 15MM FROM PHANTOM

Communication System: Wi-Fi 2450; Frequency: 2412 MHz; Duty Cycle: 1:1

Medium: 2450 Glycol Body; Medium parameters used: $f = 2450$ MHz; $\sigma = 2.03$ mho/m; $\epsilon_r = 47.9$; $\rho = 1000$ kg/m³

DASY4 Configuration:

- Probe: ES3DV3 - SN3037; ConvF(4.24, 4.24, 4.24); Calibrated: 4/13/2011
- Sensor-Surface: 4mm (Mechanical Surface Detection)
- Electronics: DAE4 Sn702; Calibrated: 4/14/2011
- Phantom: R1_ Section 2, Amy Twin, Rev3 (3-Feb-10); Type: Amy Twin Flat; Serial: n/a;
- Measurement SW: DASY4, V4.7 Build 80; Postprocessing SW: SEMCAD, V1.8 Build 186

Amy Twin Phone Template/Area Scan - Normal Extended Body (15mm) (16x7x1): Measurement grid: dx=15mm, dy=15mm

Maximum value of SAR (measured) = 0.212 mW/g

Amy Twin Phone Template/5x5x7 Zoom Scan (<=3GHz) (5x5x7)/Cube 0: Measurement grid: dx=8mm, dy=8mm, dz=5mm

Reference Value = 9.01 V/m; Power Drift = -0.064 dB

Peak SAR (extrapolated) = 0.419 W/kg

SAR(1 g) = 0.218 mW/g; SAR(10 g) = 0.111 mW/g

Maximum value of SAR (measured) = 0.241 mW/g

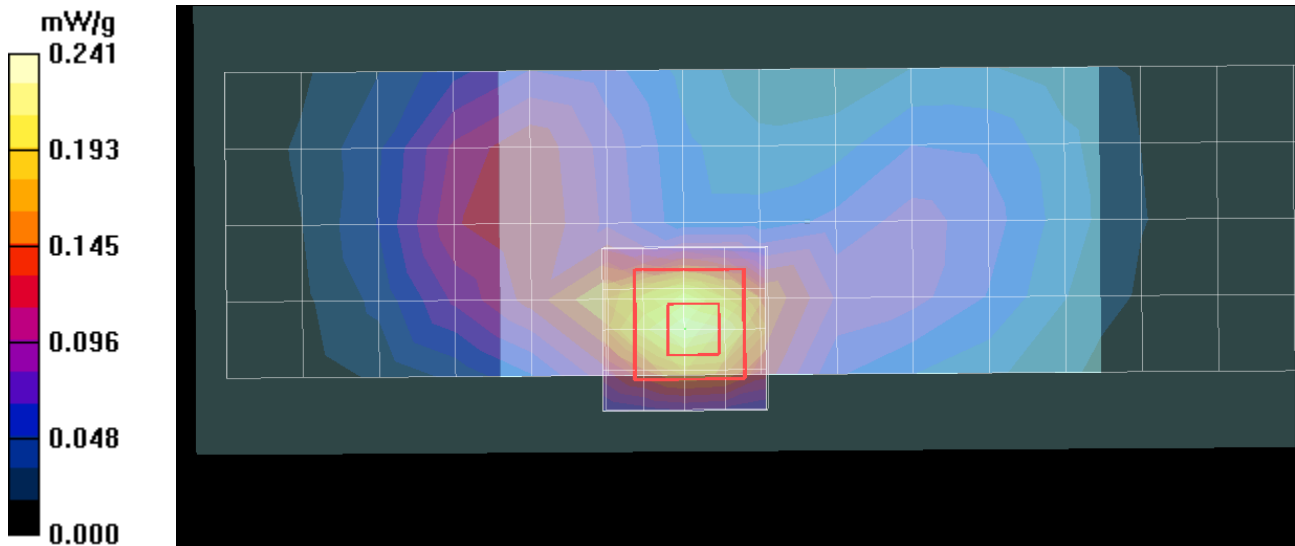

Appendix 4

SAR distribution plots for Mobile Hotspot Configuration

Test Laboratory: Motorola Mobility GPRS 850 Mobile Hotspot

DUT: Serial: 356472040000268, FCC ID: IHDP56MA2

Procedure Notes: Pwr Step: 5, Battery Model #: SNN5891A Test Configuration = Back Surface 10mm from Phantom
Communication System: GPRS 850 - Class 12; Frequency: 836.6 MHz; Duty Cycle: 1:2.075

Medium: Low Freq Body; Medium parameters used: $f = 835$ MHz; $\sigma = 0.97$ mho/m; $\epsilon_r = 54.6$; $\rho = 1000$ kg/m³

DASY4 Configuration:

- Probe: ES3DV3 - SN3184; ConvF(6.1, 6.1, 6.1); Calibrated: 3/11/2011
- Sensor-Surface: 4mm (Mechanical Surface Detection)
- Electronics: DAE4 Sn702; Calibrated: 4/14/2011
- Phantom: R#2_ Section 2, Amy Twin, Rev3 (3-Feb-10); Type: Amy Twin Flat; Serial: n/a;
- Measurement SW: DASY4, V4.7 Build 80; Postprocessing SW: SEMCAD, V1.8 Build 186

Amy Twin Phone Template/Area Scan - Normal Extended Body (15mm) (16x7x1): Measurement grid:
dx=15mm, dy=15mm

Maximum value of SAR (measured) = 1.11 mW/g

Amy Twin Phone Template/5x5x7 Zoom Scan (<=3GHz), - to correct max out (5x5x7)/Cube 0:

Measurement grid: dx=8mm, dy=8mm, dz=5mm

Reference Value = 33.6 V/m; Power Drift = -0.954 dB

Maximum value of SAR (measured) = 0.979 mW/g

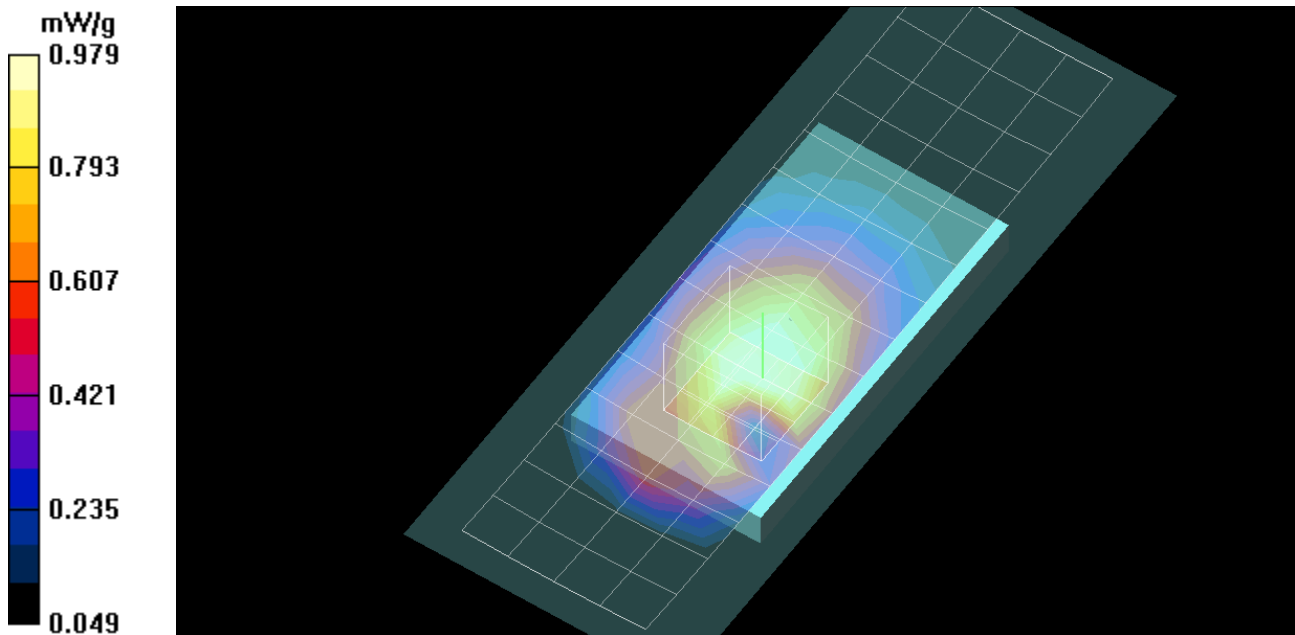

Test Laboratory: Motorola Mobility WCDMA 850 Mobile Hotspot

DUT: Serial: 356472040000268, FCC ID: IHDP56MA2

Procedure Notes: Pwr Step: All Up Bits Battery Model #: SNN5891A Test Configuration = Back of Phone 10mm from Phantom

Communication System: 3G-WCDMA 850; Frequency: 836 MHz; Duty Cycle: 1:1

Medium: Low Freq Body; Medium parameters used: $f = 835$ MHz; $\sigma = 0.97$ mho/m; $\epsilon_r = 54.6$; $\rho = 1000$ kg/m³

DASY4 Configuration:

- Probe: ES3DV3 - SN3184; ConvF(6.1, 6.1, 6.1); Calibrated: 3/11/2011
- Sensor-Surface: 4mm (Mechanical Surface Detection)
- Electronics: DAE4 Sn702; Calibrated: 4/14/2011
- Phantom: R#2_ Section 2, Amy Twin, Rev3 (3-Feb-10); Type: Amy Twin Flat; Serial: n/a;
- Measurement SW: DASY4, V4.7 Build 80; Postprocessing SW: SEMCAD, V1.8 Build 186

Amy Twin Phone Template/Area Scan - Normal Extended Body (10mm) (24x10x1): Measurement grid: dx=10mm, dy=10mm

Maximum value of SAR (measured) = 0.757 mW/g

Amy Twin Phone Template/5x5x7 Zoom Scan (<=3GHz), - to correct max out (5x5x7)/Cube 0:

Measurement grid: dx=8mm, dy=8mm, dz=5mm

Reference Value = 27.5 V/m; Power Drift = 0.030 dB

Peak SAR (extrapolated) = 1.18 W/kg

SAR(1 g) = 0.674 mW/g; SAR(10 g) = 0.408 mW/g

Maximum value of SAR (measured) = 0.763 mW/g

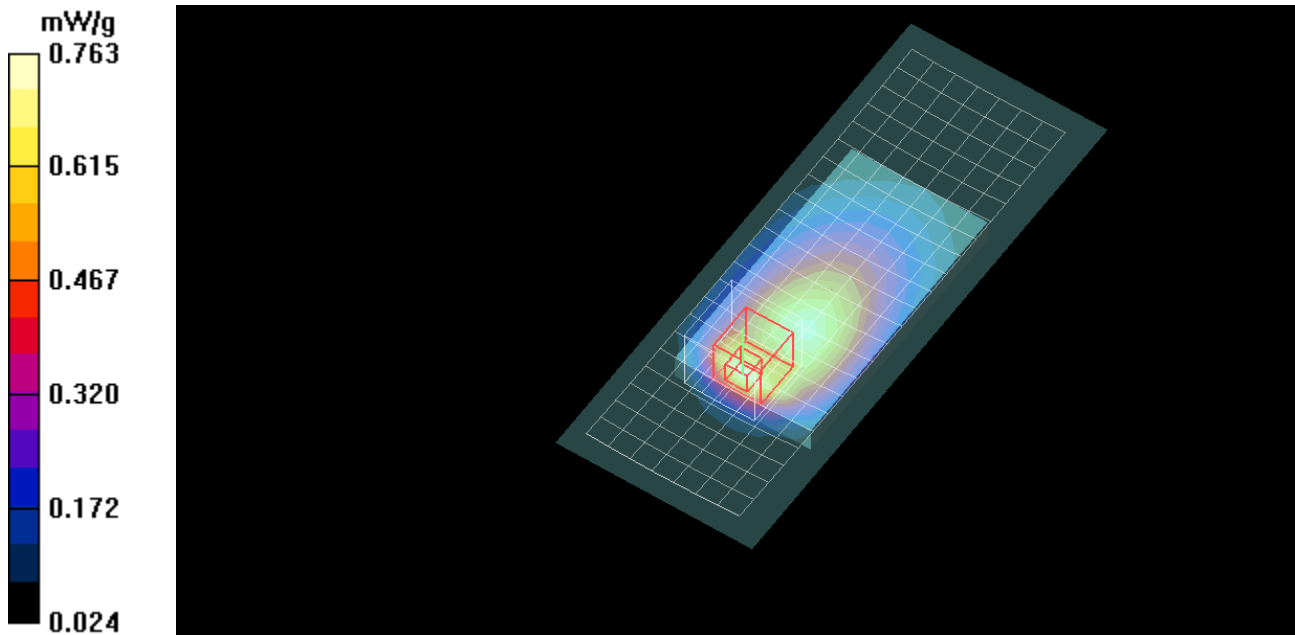

Test Laboratory: Motorola Mobility WCDMA 1900 Mobile Hotspot

DUT: Serial: 356472040000268, FCC ID: IHDP56MA2

Procedure Notes: Pwr Step: All Up Bits Battery Model #: SNN5891A Test Configuration = Back of Phone 10mm from Phantom

Communication System: 3G/WCDMA 1900; Frequency: 1907.5 MHz; Duty Cycle: 1:1

Medium: Regular Glycol Body 1750/1880; Medium parameters used: $f = 1880$ MHz; $\sigma = 1.59$ mho/m; $\epsilon_r = 50.7$; $\rho = 1000$ kg/m³

DASY4 Configuration:

- Probe: ES3DV3 - SN3184; ConvF(4.9, 4.9, 4.9); Calibrated: 3/11/2011
- Sensor-Surface: 4mm (Mechanical Surface Detection)
- Electronics: DAE4 Sn702; Calibrated: 4/14/2011
- Phantom: R#2_ Section 1, Amy Twin, Rev3 (3-Feb-10); Type: Amy Twin Flat; Serial: n/a;
- Measurement SW: DASY4, V4.7 Build 80; Postprocessing SW: SEMCAD, V1.8 Build 186

Amy Twin Phone Template/Area Scan - Full Body (15mm) (18x8x1): Measurement grid: dx=15mm, dy=15mm

Maximum value of SAR (measured) = 1.38 mW/g

Amy Twin Phone Template/5x5x7 Zoom Scan (<=3GHz) (5x5x7)/Cube 0: Measurement grid: dx=8mm, dy=8mm, dz=5mm

Reference Value = 25.2 V/m; Power Drift = 0.130 dB

Peak SAR (extrapolated) = 2.25 W/kg

SAR(1 g) = 1.32 mW/g; SAR(10 g) = 0.785 mW/g

Maximum value of SAR (measured) = 1.42 mW/g

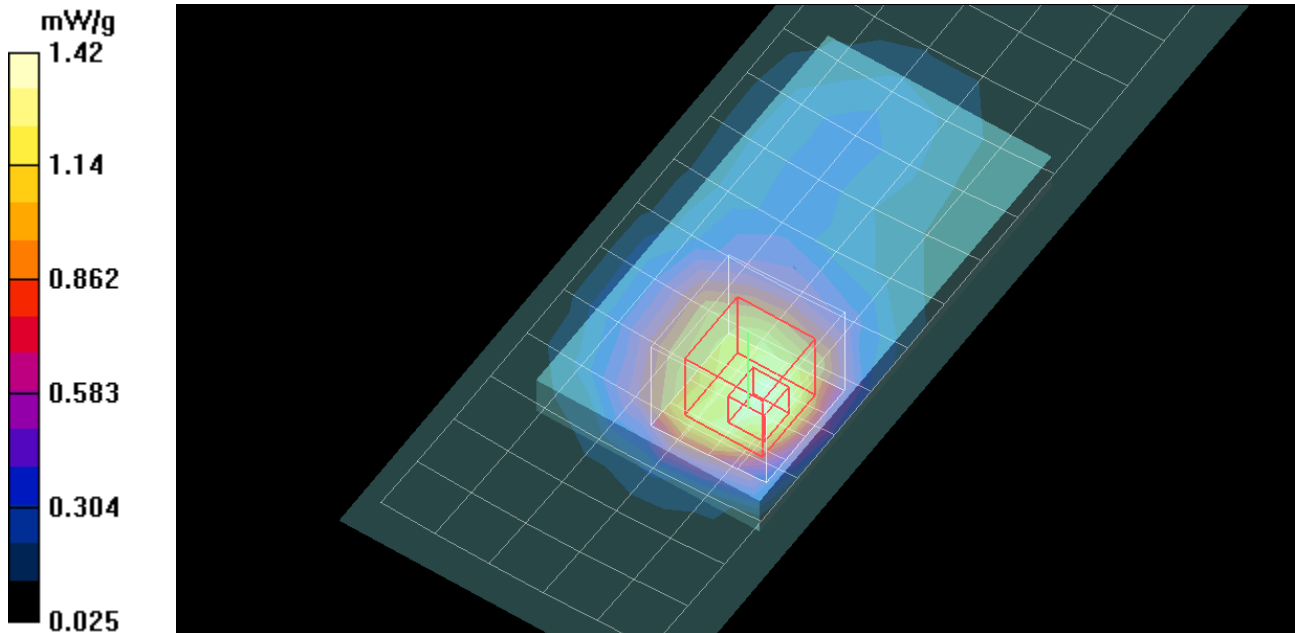

Test Laboratory: Motorola WiFi 2450MHz WiFi Hotspot Configuration

DUT: Serial: 356472040014939, FCC ID: IHDP56MA2

Procedure Notes: 802.11b 11Mbps Battery Model #: SNN5891A Test Configuration: BACK OF PHONE 10MM FROM PHANTOM

Communication System: Wi-Fi 2450; Frequency: 2437 MHz; Duty Cycle: 1:1

Medium: 2450 Glycol Body; Medium parameters used: $f = 2450$ MHz; $\sigma = 2.03$ mho/m; $\epsilon_r = 47.9$; $\rho = 1000$ kg/m³

DASY4 Configuration:

- Probe: ES3DV3 - SN3037; ConvF(4.24, 4.24, 4.24); Calibrated: 4/13/2011
- Sensor-Surface: 4mm (Mechanical Surface Detection)
- Electronics: DAE4 Sn702; Calibrated: 4/14/2011
- Phantom: R1_ Section 2, Amy Twin, Rev3 (3-Feb-10); Type: Amy Twin Flat; Serial: n/a;
- Measurement SW: DASY4, V4.7 Build 80; Postprocessing SW: SEMCAD, V1.8 Build 186

Amy Twin Phone Template/Area Scan - Normal Extended Body (15mm) (16x7x1): Measurement grid: dx=15mm, dy=15mm

Maximum value of SAR (measured) = 0.512 mW/g

Amy Twin Phone Template/5x5x7 Zoom Scan (<=3GHz) (5x5x7)/Cube 0: Measurement grid: dx=8mm, dy=8mm, dz=5mm

Reference Value = 9.81 V/m; Power Drift = -0.004 dB

Peak SAR (extrapolated) = 0.953 W/kg

SAR(1 g) = 0.453 mW/g; SAR(10 g) = 0.209 mW/g

Maximum value of SAR (measured) = 0.518 mW/g

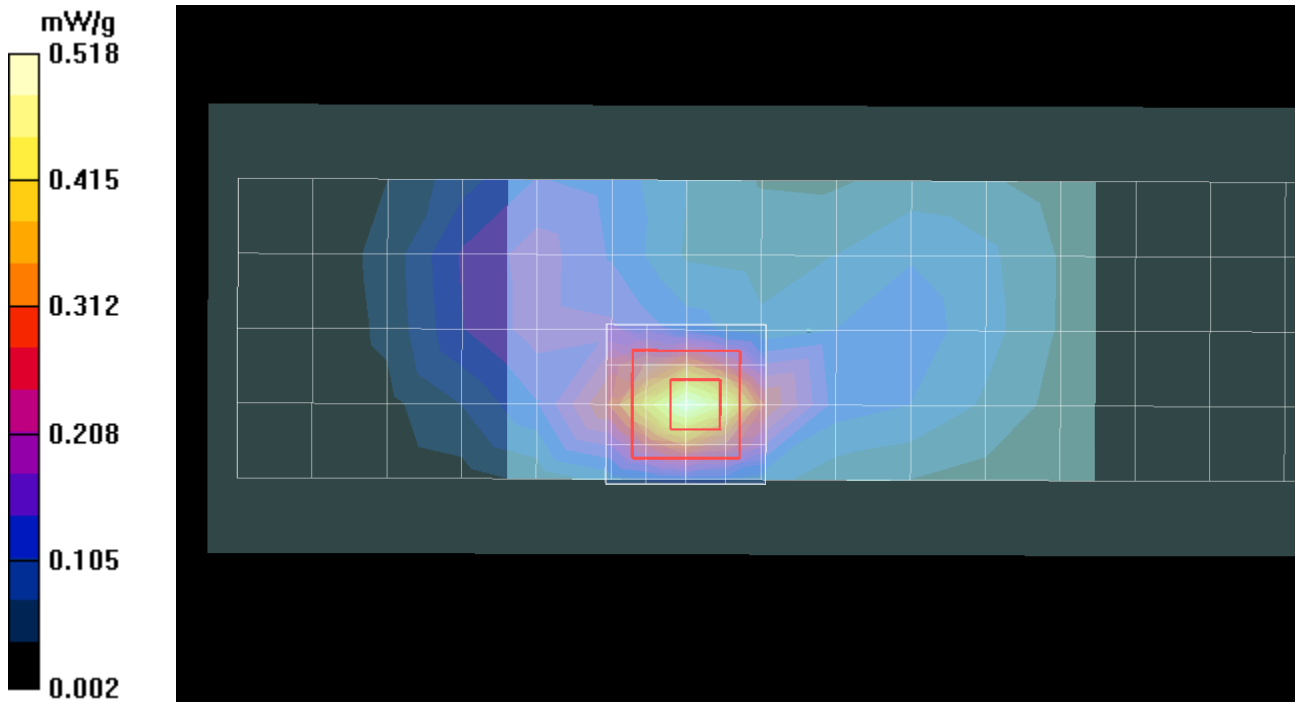

Test Laboratory: Motorola Mobility GPRS 1900 Mobile Hotspot

DUT: Serial: 356472040000268, FCC ID: IHDP56MA2

Procedure Notes: Pwr Step: 0 Battery Model #: SNN5891A Test Configuration = BOTTOM EDGE OF PHONE
10MM FROM PHANTOM

Communication System: GPRS 1900 - Class 12; Frequency: 1880 MHz; Duty Cycle: 1:2.075

Medium: Regular Glycol Body 1750/1880; Medium parameters used: $f = 1880$ MHz; $\sigma = 1.59$ mho/m; $\epsilon_r = 50.8$; $\rho = 1000$ kg/m³

DASY4 Configuration:

- Probe: ES3DV3 - SN3184; ConvF(4.9, 4.9, 4.9); Calibrated: 3/11/2011
- Sensor-Surface: 4mm (Mechanical Surface Detection)
- Electronics: DAE4 Sn702; Calibrated: 4/14/2011
- Phantom: R#2_ Section 1, Amy Twin, Rev3 (3-Feb-10); Type: Amy Twin Flat; Serial: n/a;
- Measurement SW: DASY4, V4.7 Build 80; Postprocessing SW: SEMCAD, V1.8 Build 186

Amy Twin Phone Template/Area Scan - Normal Extended Body (15mm) (16x7x1): Measurement grid:
dx=15mm, dy=15mm

Maximum value of SAR (measured) = 0.597 mW/g

Amy Twin Phone Template/5x5x7 Zoom Scan (<=3GHz) (5x5x7)/Cube 0: Measurement grid: dx=8mm,
dy=8mm, dz=5mm

Reference Value = 18.7 V/m; Power Drift = 0.038 dB

Peak SAR (extrapolated) = 0.931 W/kg

SAR(1 g) = 0.587 mW/g; SAR(10 g) = 0.318 mW/g

Maximum value of SAR (measured) = 0.676 mW/g

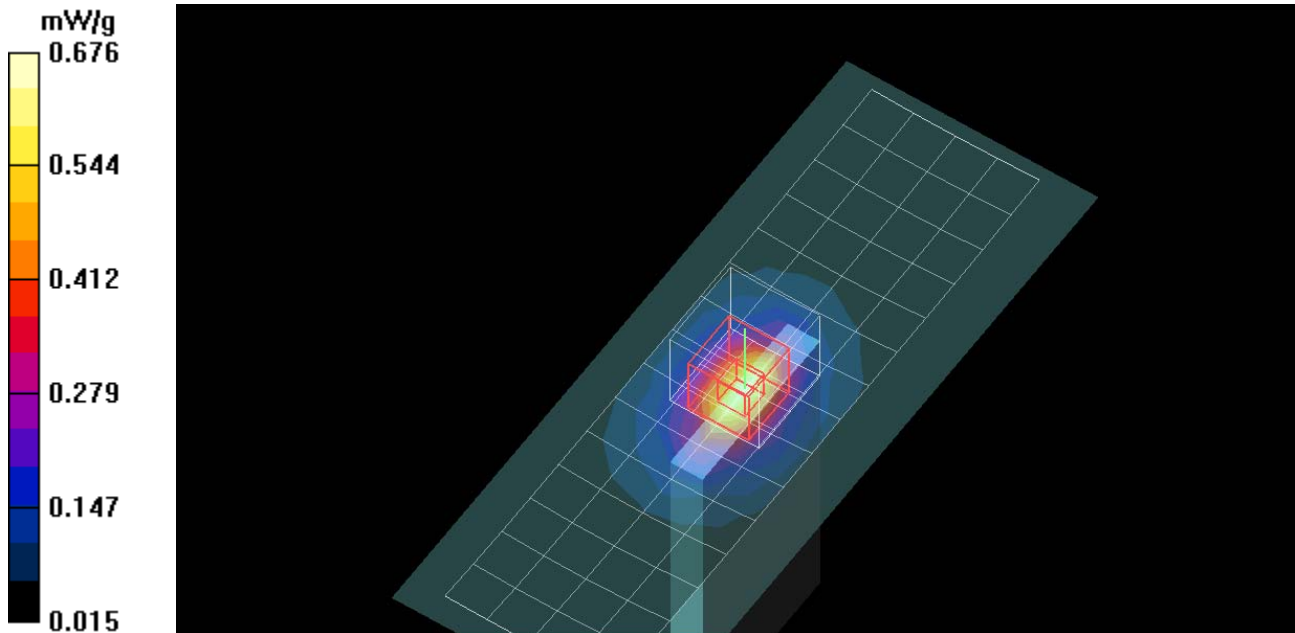

Appendix 5

SAR distribution plots for Simultaneous Evaluation

WCDMA 1900 and WiFi Simultaneous Evaluation

DASY4 Configuration for MegaZoom, DASY4 Amy Twin Phone Template/Mega Zoom Scan ($\leq 3\text{GHz}$):

Date/Time: 10/17/2011 5:07:30 PM

DUT: Serial: 356472040000268, FCC ID: IHDP56MA2

Communication System: 3G/WCDMA 1900; Frequency: 1907.5 MHz; Duty Cycle: 1:1

Medium: Regular Glycol Body 1750/1880 Medium parameters used: $f = 1880\text{ MHz}$; $\sigma = 1.56\text{ mho/m}$; $\epsilon_r = 51.2$; $\rho = 1000\text{ kg/m}^3$

Phantom section: Flat Section

Measurement Standard: DASY4 (High Precision Assessment)

- Probe: ES3DV3 - SN3184; ConvF(4.9, 4.9, 4.9); Calibrated: 3/11/2011
 - Sensor-Surface: 4mm (Mechanical Surface Detection)
 - Electronics: DAE4 Sn702; Calibrated: 4/14/2011
 - Phantom: R#2_ Section 1, Amy Twin, Rev3 (3-Feb-10); Type: Amy Twin Flat; Serial: n/a
 - Measurement SW: DASY4, V4.7 Build 80
-

DASY4 Configuration for MegaZoom/Amy Twin Phone Template/Mega Zoom Scan ($\leq 3\text{GHz}$):

Date/Time: 7/29/2011 11:54:52 AM

DUT: Serial: 356472040014939, FCC ID: IHDP56MA2

Communication System: Wi-Fi 2450; Frequency: 2437 MHz; Duty Cycle: 1:1

Medium: 2450 Glycol Body Medium parameters used: $f = 2450\text{ MHz}$; $\sigma = 2.04\text{ mho/m}$; $\epsilon_r = 47.5$; $\rho = 1000\text{ kg/m}^3$

Phantom section: Flat Section

Measurement Standard: DASY4 (High Precision Assessment)

- Probe: ES3DV3 - SN3184; ConvF(4.33, 4.33, 4.33); Calibrated: 3/11/2011
 - Sensor-Surface: 4mm (Mechanical Surface Detection)
 - Electronics: DAE4 Sn699; Calibrated: 9/20/2010
 - Phantom: R#2_ Section 2, Amy Twin, Rev3 (3-Feb-10); Type: Amy Twin Flat; Serial: n/a
 - Measurement SW: DASY4, V4.7 Build 80
-

Multi Band Result:

SAR(1 g) = 1.33 mW/g; SAR(10 g) = 0.808 mW/g

Maximum value of SAR (measured) = 1.43 mW/g

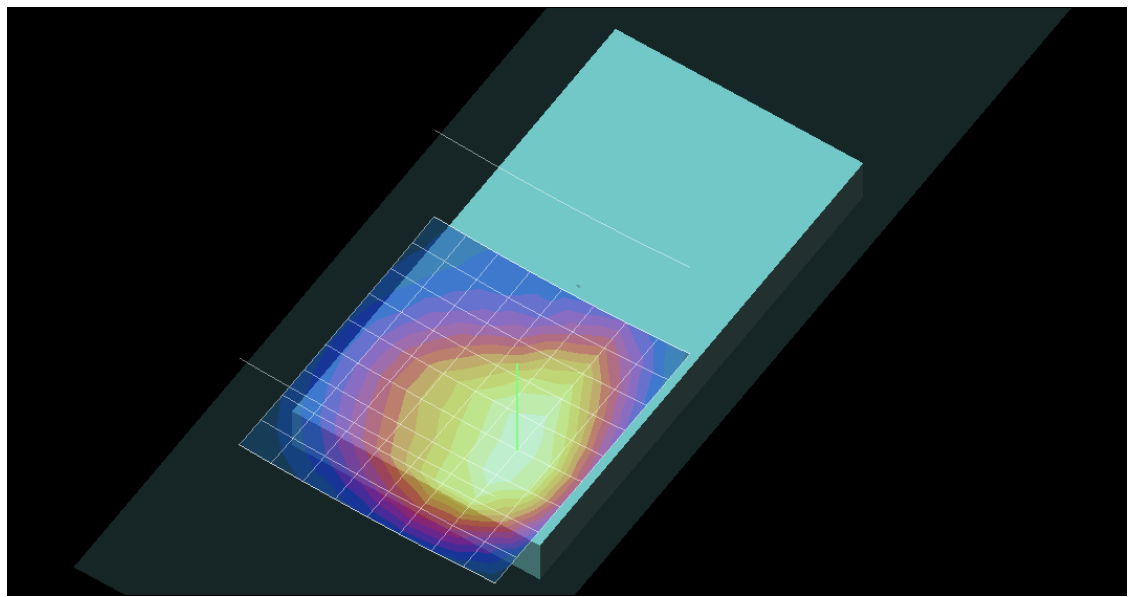
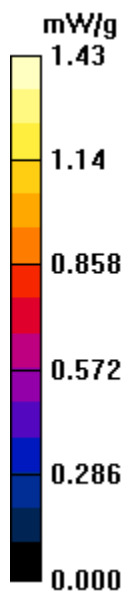

Appendix 6
Measurement Uncertainty Budget

<i>a</i>	<i>b</i>	<i>c</i>	<i>d</i>	<i>e = f(d,k)</i>	<i>f</i>	<i>g</i>	<i>h = c x f / e</i>	<i>i = c x g / e</i>	<i>k</i>
Uncertainty Component	IEEE 1528 section	Tol. (± %)	Prob Dist	Div.	<i>c_i</i> (1 g)	<i>c_i</i> (10 g)	1 g <i>u_i</i> (±%)	10 g <i>u_i</i> (±%)	<i>v_i</i>
Measurement System									
Probe Calibration	E.2.1	5.9	N	1.00	1	1	5.9	5.9	∞
Axial Isotropy	E.2.2	4.7	R	1.73	0.707	0.707	1.9	1.9	∞
Hemispherical Isotropy	E.2.2	9.6	R	1.73	0.707	0.707	3.9	3.9	∞
Boundary Effect	E.2.3	1.0	R	1.73	1	1	0.6	0.6	∞
Linearity	E.2.4	4.7	R	1.73	1	1	2.7	2.7	∞
System Detection Limits	E.2.5	1.0	R	1.73	1	1	0.6	0.6	∞
Readout Electronics	E.2.6	0.3	N	1.00	1	1	0.3	0.3	∞
Response Time	E.2.7	1.1	R	1.73	1	1	0.6	0.6	∞
Integration Time	E.2.8	1.1	R	1.73	1	1	0.6	0.6	∞
RF Ambient Conditions - Noise	E.6.1	3.0	R	1.73	1	1	1.7	1.7	∞
RF Ambient Conditions - Reflections	E.6.1	0.0	R	1.73	1	1	0.0	0.0	∞
Probe Positioner Mech. Tolerance	E.6.2	0.4	R	1.73	1	1	0.2	0.2	∞
Probe Positioning w.r.t Phantom	E.6.3	1.4	R	1.73	1	1	0.8	0.8	∞
Max. SAR Evaluation (ext., int., avg.)	E.5	3.4	R	1.73	1	1	2.0	2.0	∞
Test sample Related									
Test Sample Positioning	E.4.2	3.2	N	1.00	1	1	3.2	3.2	29
Device Holder Uncertainty	E.4.1	4.0	N	1.00	1	1	4.0	4.0	8
SAR drift	6.6.2	5.0	R	1.73	1	1	2.9	2.9	∞
Phantom and Tissue Parameters									
Phantom Uncertainty	E.3.1	4.0	R	1.73	1	1	2.3	2.3	∞
Liquid Conductivity (target)	E.3.2	5.0	R	1.73	0.64	0.43	1.8	1.2	∞
Liquid Conductivity (measurement)	E.3.3	3.3	N	1.00	0.64	0.43	2.1	1.4	∞
Liquid Permittivity (target)	E.3.2	5.0	R	1.73	0.6	0.49	1.7	1.4	∞
Liquid Permittivity (measurement)	E.3.3	1.9	N	1.00	0.6	0.49	1.1	0.9	∞
Combined Standard Uncertainty			RSS				11.1	10.8	411
Expanded Uncertainty (95% CONFIDENCE LEVEL)			<i>k=2</i>				22.2	21.6	

Appendix 7
Probe Calibration Certificate



Accredited by the Swiss Accreditation Service (SAS)
The Swiss Accreditation Service is one of the signatories to the EA
Multilateral Agreement for the recognition of calibration certificates

Accreditation No.: **SCS 108**

Client **Motorola MDB**

Certificate No: **ES3-3184_Mar11**

CALIBRATION CERTIFICATE

Object **ES3DV3 - SN:3184**

Calibration procedure(s) **QA CAL-01.v7, QA CAL-23.v4, QA CAL-25.v3
Calibration procedure for dosimetric E-field probes**

Calibration date: **March 11, 2011**

This calibration certificate documents the traceability to national standards, which realize the physical units of measurements (SI).
The measurements and the uncertainties with confidence probability are given on the following pages and are part of the certificate.

All calibrations have been conducted in the closed laboratory facility: environment temperature (22 ± 3)°C and humidity < 70%.

Calibration Equipment used (M&TE critical for calibration)

Primary Standards	ID	Cal Date (Certificate No.)	Scheduled Calibration
Power meter E4419B	GB41293874	01-Apr-10 (No. 217-01136)	Apr-11
Power sensor E4412A	MY41495277	01-Apr-10 (No. 217-01136)	Apr-11
Power sensor E4412A	MY41498087	01-Apr-10 (No. 217-01136)	Apr-11
Reference 3 dB Attenuator	SN: S5054 (3c)	30-Mar-10 (No. 217-01159)	Mar-11
Reference 20 dB Attenuator	SN: S5086 (20b)	30-Mar-10 (No. 217-01161)	Mar-11
Reference 30 dB Attenuator	SN: S5129 (30b)	30-Mar-10 (No. 217-01160)	Mar-11
Reference Probe ES3DV2	SN: 3013	29-Dec-10 (No. ES3-3013_Dec10)	Dec-11
DAE4	SN: 654	23-Apr-10 (No. DAE4-654_Apr10)	Apr-11
Secondary Standards	ID	Check Date (in house)	Scheduled Check
RF generator HP 8648C	US3642U01700	4-Aug-99 (in house check Oct-09)	In house check: Oct-11
Network Analyzer HP 8753E	US37390585	18-Oct-01 (in house check Oct-10)	In house check: Oct-11

	Name	Function	Signature
Calibrated by:	Jeton Kastrati	Laboratory Technician	
Approved by:	Katja Pokovic	Technical Manager	

Issued: March 16, 2011

This calibration certificate shall not be reproduced except in full without written approval of the laboratory.



Accredited by the Swiss Accreditation Service (SAS)
The Swiss Accreditation Service is one of the signatories to the EA
Multilateral Agreement for the recognition of calibration certificates

Accreditation No.: SCS 108

Glossary:

TSL	tissue simulating liquid
NORM _{x,y,z}	sensitivity in free space
ConvF	sensitivity in TSL / NORM _{x,y,z}
DCP	diode compression point
CF	crest factor (1/duty_cycle) of the RF signal
A, B, C	modulation dependent linearization parameters
Polarization φ	φ rotation around probe axis
Polarization ϑ	ϑ rotation around an axis that is in the plane normal to probe axis (at measurement center), i.e., $\vartheta = 0$ is normal to probe axis

Calibration is Performed According to the Following Standards:

- IEEE Std 1528-2003, "IEEE Recommended Practice for Determining the Peak Spatial-Averaged Specific Absorption Rate (SAR) in the Human Head from Wireless Communications Devices: Measurement Techniques", December 2003
- IEC 62209-1, "Procedure to measure the Specific Absorption Rate (SAR) for hand-held devices used in close proximity to the ear (frequency range of 300 MHz to 3 GHz)", February 2005

Methods Applied and Interpretation of Parameters:

- NORM_{x,y,z}**: Assessed for E-field polarization $\vartheta = 0$ ($f \leq 900$ MHz in TEM-cell; $f > 1800$ MHz: R22 waveguide). NORM_{x,y,z} are only intermediate values, i.e., the uncertainties of NORM_{x,y,z} does not affect the E²-field uncertainty inside TSL (see below ConvF).
- NORM(f)_{x,y,z}** = NORM_{x,y,z} * frequency_response (see Frequency Response Chart). This linearization is implemented in DASY4 software versions later than 4.2. The uncertainty of the frequency response is included in the stated uncertainty of ConvF.
- DCP_{x,y,z}**: DCP are numerical linearization parameters assessed based on the data of power sweep with CW signal (no uncertainty required). DCP does not depend on frequency nor media.
- PAR**: PAR is the Peak to Average Ratio that is not calibrated but determined based on the signal characteristics
- A_{x,y,z}; B_{x,y,z}; C_{x,y,z}** are numerical linearization parameters in dB assessed based on the data of power sweep for specific modulation signal. The parameters do not depend on frequency nor media.
- VR**: VR is the validity range of the calibration related to the average diode voltage or DAE voltage in mV.
- ConvF and Boundary Effect Parameters**: Assessed in flat phantom using E-field (or Temperature Transfer Standard for $f \leq 800$ MHz) and inside waveguide using analytical field distributions based on power measurements for $f > 800$ MHz. The same setups are used for assessment of the parameters applied for boundary compensation (alpha, depth) of which typical uncertainty values are given. These parameters are used in DASY4 software to improve probe accuracy close to the boundary. The sensitivity in TSL corresponds to NORM_{x,y,z} * ConvF whereby the uncertainty corresponds to that given for ConvF. A frequency dependent ConvF is used in DASY version 4.4 and higher which allows extending the validity from ± 50 MHz to ± 100 MHz.
- Spherical isotropy (3D deviation from isotropy)**: in a field of low gradients realized using a flat phantom exposed by a patch antenna.
- Sensor Offset**: The sensor offset corresponds to the offset of virtual measurement center from the probe tip (on probe axis). No tolerance required.

Probe ES3DV3

SN:3184

Manufactured: August 19, 2008
Calibrated: March 11, 2011

Calibrated for DASY/EASY Systems
(Note: non-compatible with DASY2 system!)

DASY/EASY - Parameters of Probe: ES3DV3 - SN:3184

Basic Calibration Parameters

	Sensor X	Sensor Y	Sensor Z	Unc (k=2)
Norm ($\mu\text{V}/(\text{V}/\text{m})^2$) ^A	1.27	1.40	1.27	$\pm 10.1 \%$
DCP (mV) ^B	96.8	98.9	99.5	

Modulation Calibration Parameters

UID	Communication System Name	PAR		A dB	B dB	C dB	VR mV	Unc ^E (k=2)
10000	CW	0.00	X	0.00	0.00	1.00	110.8	$\pm 3.0 \%$
			Y	0.00	0.00	1.00	117.2	
			Z	0.00	0.00	1.00	107.9	

The reported uncertainty of measurement is stated as the standard uncertainty of measurement multiplied by the coverage factor $k=2$, which for a normal distribution corresponds to a coverage probability of approximately 95%.

^A The uncertainties of NormX,Y,Z do not affect the E^2 -field uncertainty inside TSL (see Pages 5 and 6).

^B Numerical linearization parameter: uncertainty not required.

^E Uncertainty is determined using the max. deviation from linear response applying rectangular distribution and is expressed for the square of the field value.

DASY/EASY - Parameters of Probe: ES3DV3 - SN:3184

Calibration Parameter Determined in Head Tissue Simulating Media

f (MHz) ^c	Relative Permittivity ^f	Conductivity (S/m) ^f	ConvF X	ConvF Y	ConvF Z	Alpha	Depth (mm)	Unct. (k=2)
835	41.5	0.90	6.11	6.11	6.11	1.00	1.04	± 12.0 %
1810	40.0	1.40	5.11	5.11	5.11	0.93	1.08	± 12.0 %
1950	40.0	1.40	4.93	4.93	4.93	0.96	1.07	± 12.0 %
2450	39.2	1.80	4.48	4.48	4.48	0.73	1.28	± 12.0 %

^c Frequency validity of ± 100 MHz only applies for DASY v4.4 and higher (see Page 2), else it is restricted to ± 50 MHz. The uncertainty is the RSS of the ConvF uncertainty at calibration frequency and the uncertainty for the indicated frequency band.

^f At frequencies below 3 GHz, the validity of tissue parameters (ϵ and σ) can be relaxed to ± 10% if liquid compensation formula is applied to measured SAR values. At frequencies above 3 GHz, the validity of tissue parameters (ϵ and σ) is restricted to ± 5%. The uncertainty is the RSS of the ConvF uncertainty for indicated target tissue parameters.

DASY/EASY - Parameters of Probe: ES3DV3- SN:3184

Calibration Parameter Determined in Body Tissue Simulating Media

f (MHz) ^G	Relative Permittivity ^F	Conductivity (S/m) ^F	ConvF X	ConvF Y	ConvF Z	Alpha	Depth (mm)	Unct. (k=2)
835	55.2	0.97	6.10	6.10	6.10	1.00	1.00	± 12.0 %
1810	53.3	1.52	4.90	4.90	4.90	0.87	1.26	± 12.0 %
1950	53.3	1.52	4.86	4.86	4.86	0.73	1.38	± 12.0 %
2450	52.7	1.95	4.33	4.33	4.33	1.00	1.03	± 12.0 %

^G Frequency validity of ± 100 MHz only applies for DASY v4.4 and higher (see Page 2), else it is restricted to ± 50 MHz. The uncertainty is the RSS of the ConvF uncertainty at calibration frequency and the uncertainty for the indicated frequency band.

^F At frequencies below 3 GHz, the validity of tissue parameters (ϵ and σ) can be relaxed to ± 10% if liquid compensation formula is applied to measured SAR values. At frequencies above 3 GHz, the validity of tissue parameters (ϵ and σ) is restricted to ± 5%. The uncertainty is the RSS of the ConvF uncertainty for indicated target tissue parameters.

Frequency Response of E-Field (TEM-Cell:ifi110 EXX, Waveguide: R22)

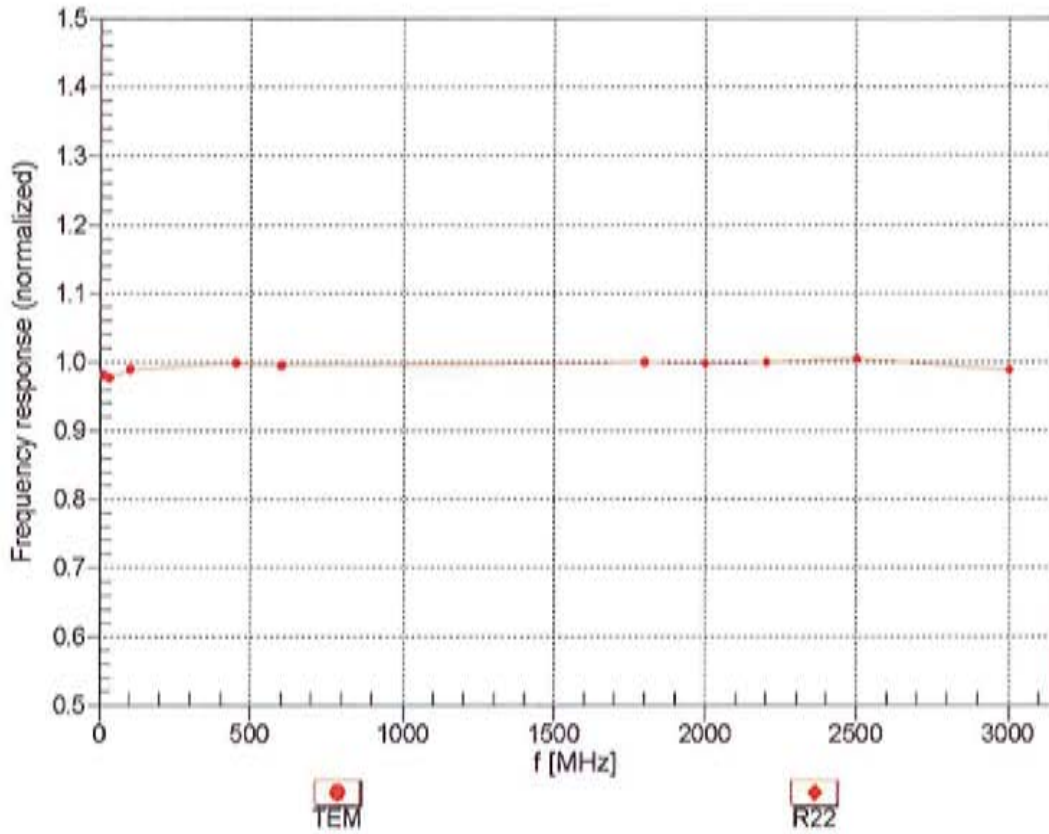

Uncertainty of Frequency Response of E-field: $\pm 6.3\%$ (k=2)

Receiving Pattern (ϕ), $\theta = 0^\circ$

f=600 MHz,TEM

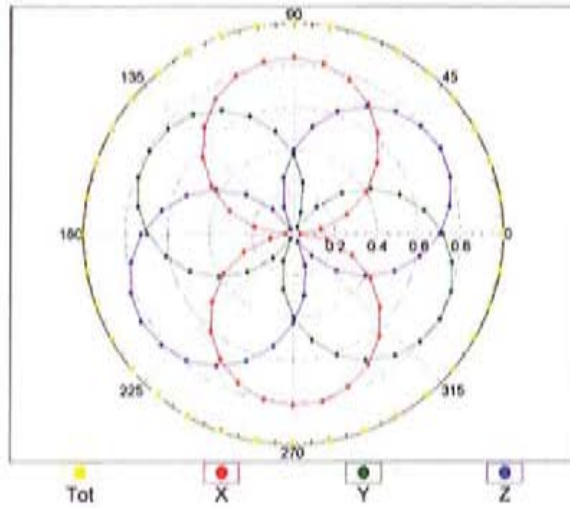

f=1800 MHz,R22

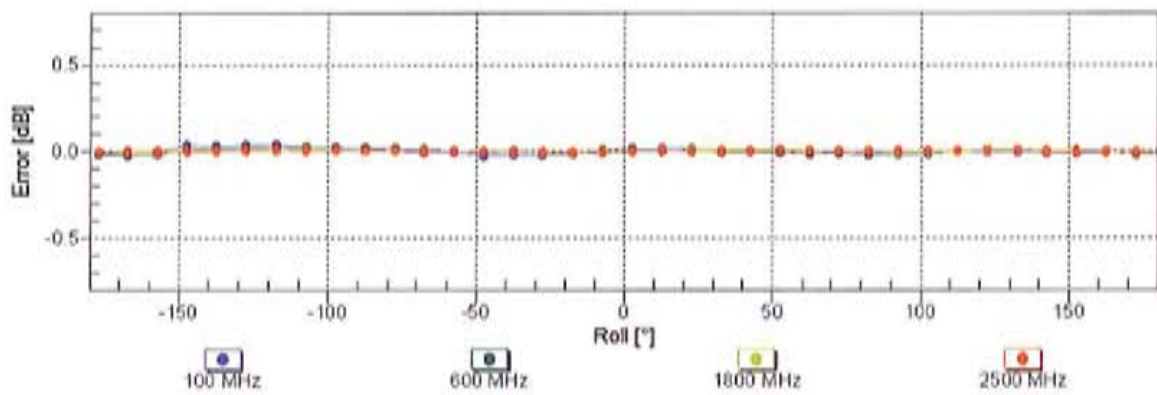
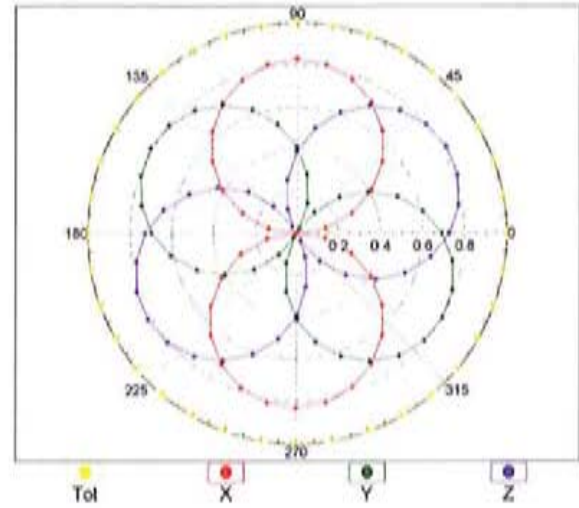

Uncertainty of Axial Isotropy Assessment: $\pm 0.5\%$ ($k=2$)

Dynamic Range f(SAR_{head}) (TEM cell , f = 900 MHz)

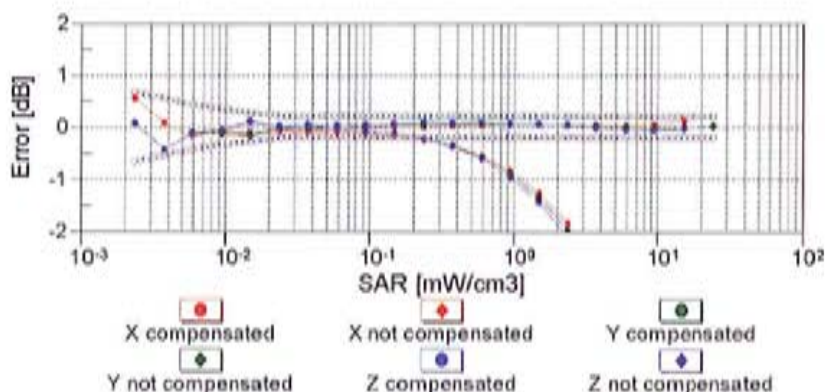
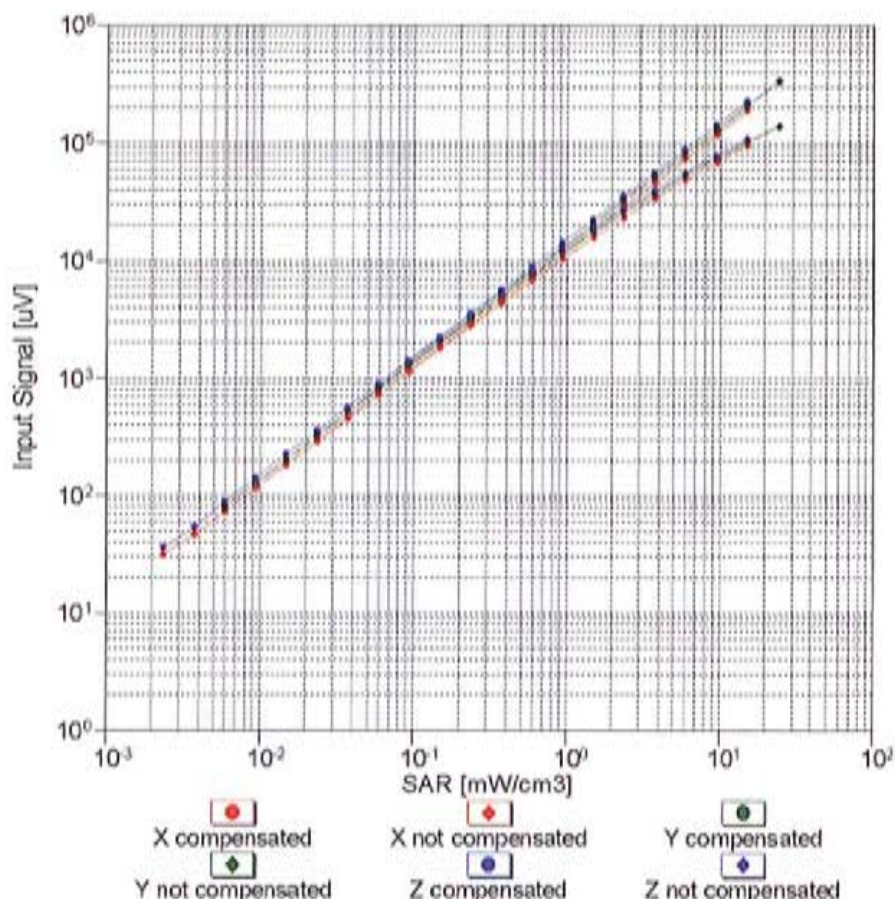

Uncertainty of Linearity Assessment: ± 0.6% (k=2)

Conversion Factor Assessment

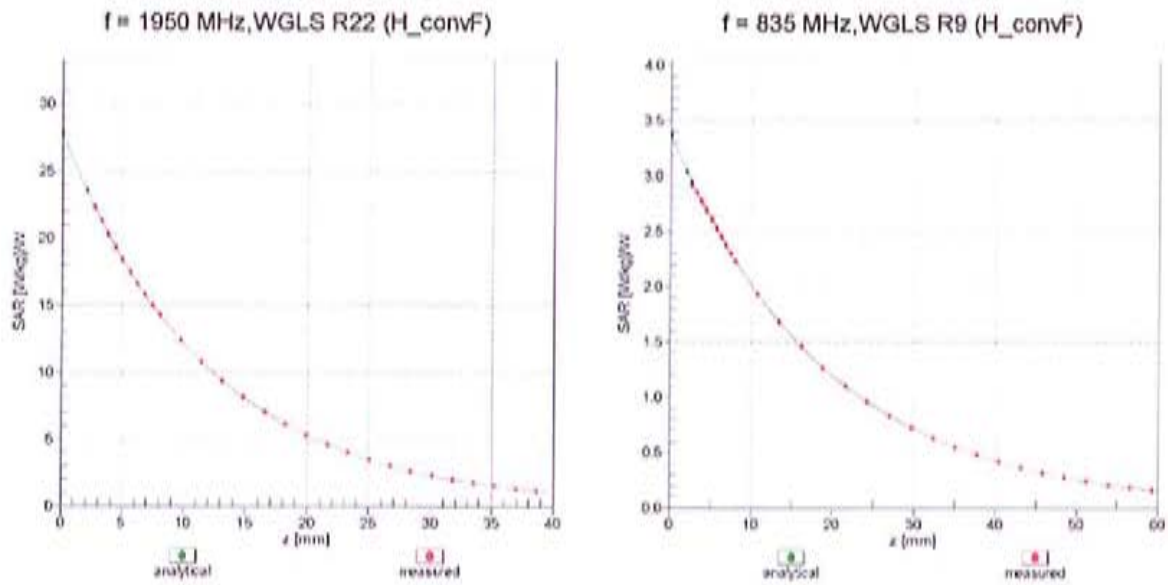

Deviation from Isotropy in Liquid Error (ϕ, θ), f = 900 MHz

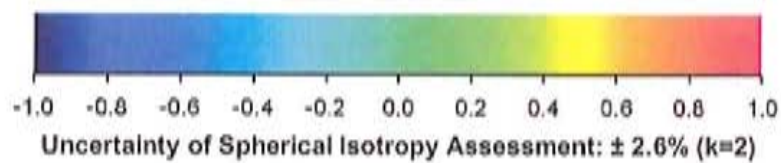
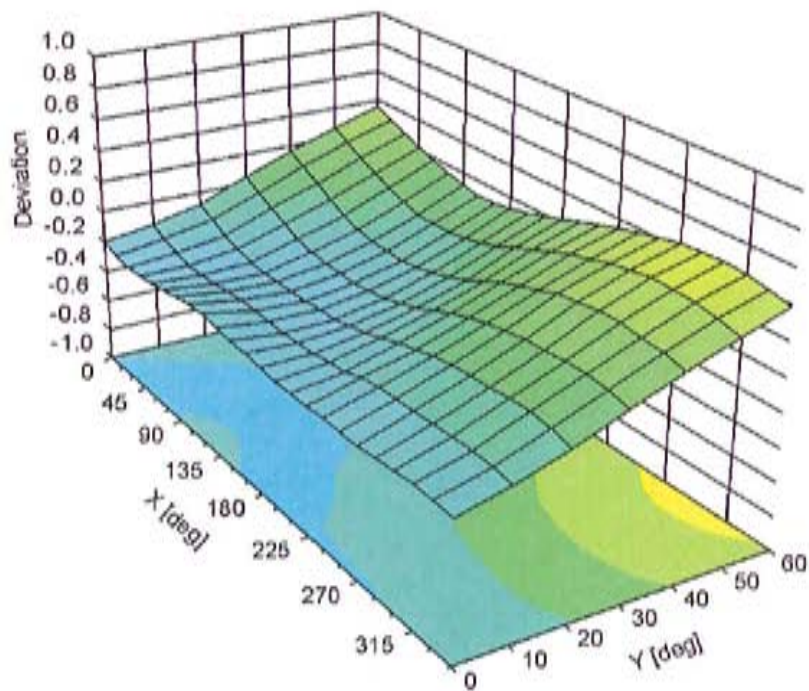

DASY/EASY - Parameters of Probe: ES3DV3 - SN:3184**Other Probe Parameters**

Sensor Arrangement	Triangular
Connector Angle (°)	Not applicable
Mechanical Surface Detection Mode	enabled
Optical Surface Detection Mode	disabled
Probe Overall Length	337 mm
Probe Body Diameter	10 mm
Tip Length	10 mm
Tip Diameter	4 mm
Probe Tip to Sensor X Calibration Point	2 mm
Probe Tip to Sensor Y Calibration Point	2 mm
Probe Tip to Sensor Z Calibration Point	2 mm
Recommended Measurement Distance from Surface	3 mm



Accredited by the Swiss Accreditation Service (SAS)
The Swiss Accreditation Service is one of the signatories to the EA
Multilateral Agreement for the recognition of calibration certificates

Accreditation No.: **SCS 108**

Client **Motorola MDb**

Certificate No: **ES3-3115_Jan11**

CALIBRATION CERTIFICATE

Object **ES3DV3 - SN:3115**

Calibration procedure(s) **QA CAL-01.v7, QA CAL-23.v4 and QA CAL-25.v3
Calibration procedure for dosimetric E-field probes**

Calibration date: **January 12, 2011**

This calibration certificate documents the traceability to national standards, which realize the physical units of measurements (SI).
The measurements and the uncertainties with confidence probability are given on the following pages and are part of the certificate.

All calibrations have been conducted in the closed laboratory facility: environment temperature (22 ± 3)°C and humidity < 70%.

Calibration Equipment used (M&TE critical for calibration)

Primary Standards	ID #	Cal Date (Certificate No.)	Scheduled Calibration
Power meter E4419B	GB41293874	1-Apr-10 (No. 217-01136)	Apr-11
Power sensor E4412A	MY41495277	1-Apr-10 (No. 217-01136)	Apr-11
Power sensor E4412A	MY41498087	1-Apr-10 (No. 217-01136)	Apr-11
Reference 3 dB Attenuator	SN: S5054 (3c)	30-Mar-10 (No. 217-01159)	Mar-11
Reference 20 dB Attenuator	SN: S5086 (20b)	30-Mar-10 (No. 217-01161)	Mar-11
Reference 30 dB Attenuator	SN: S5129 (30b)	30-Mar-10 (No. 217-01160)	Mar-11
Reference Probe ES3DV2	SN: 3013	29-Dec-10 (No. ES3-3013_Dec10)	Dec-11
DAE4	SN: 660	20-Apr-10 (No. DAE4-660_Apr10)	Apr-11
Secondary Standards	ID #	Check Date (in house)	Scheduled Check
RF generator HP 8648C	US3642U01700	4-Aug-99 (in house check Oct-09)	In house check: Oct-11
Network Analyzer HP 8753E	US37390585	18-Oct-01 (in house check Oct-10)	In house check: Oct-11

Calibrated by:	Name Jeton Kastrali	Function Laboratory Technician	Signature
Approved by:	Name Katja Pokovic	Technical Manager Technical Manager	

Issued: January 13, 2011

This calibration certificate shall not be reproduced except in full without written approval of the laboratory.



Accredited by the Swiss Accreditation Service (SAS)
The Swiss Accreditation Service is one of the signatories to the EA
Multilateral Agreement for the recognition of calibration certificates

Accreditation No.: **SCS 108**

Glossary:

TSL	tissue simulating liquid
NORM _{x,y,z}	sensitivity in free space
ConvF	sensitivity in TSL / NORM _{x,y,z}
DCP	diode compression point
CF	crest factor (1/duty_cycle) of the RF signal
A, B, C	modulation dependent linearization parameters
Polarization φ	φ rotation around probe axis
Polarization ϑ	ϑ rotation around an axis that is in the plane normal to probe axis (at measurement center), i.e., $\vartheta = 0$ is normal to probe axis

Calibration is Performed According to the Following Standards:

- IEEE Std 1528-2003, "IEEE Recommended Practice for Determining the Peak Spatial-Averaged Specific Absorption Rate (SAR) in the Human Head from Wireless Communications Devices: Measurement Techniques", December 2003
- IEC 62209-1, "Procedure to measure the Specific Absorption Rate (SAR) for hand-held devices used in close proximity to the ear (frequency range of 300 MHz to 3 GHz)", February 2005

Methods Applied and Interpretation of Parameters:

- NORM_{x,y,z}**: Assessed for E-field polarization $\vartheta = 0$ ($f \leq 900$ MHz in TEM-cell; $f > 1800$ MHz: R22 waveguide). NORM_{x,y,z} are only intermediate values, i.e., the uncertainties of NORM_{x,y,z} does not effect the E^2 -field uncertainty inside TSL (see below *ConvF*).
- NORM(*f*)_{x,y,z} = NORM_{x,y,z} * frequency_response** (see Frequency Response Chart). This linearization is implemented in DASY4 software versions later than 4.2. The uncertainty of the frequency response is included in the stated uncertainty of *ConvF*.
- DCP_{x,y,z}**: DCP are numerical linearization parameters assessed based on the data of power sweep with CW signal (no uncertainty required). DCP does not depend on frequency nor media.
- A_{x,y,z}; B_{x,y,z}; C_{x,y,z}; VR_{x,y,z}; A, B, C** are numerical linearization parameters assessed based on the data of power sweep for specific modulation signal. The parameters do not depend on frequency nor media. VR is the maximum calibration range expressed in RMS voltage across the diode.
- ConvF and Boundary Effect Parameters**: Assessed in flat phantom using E-field (or Temperature Transfer Standard for $f \leq 800$ MHz) and inside waveguide using analytical field distributions based on power measurements for $f > 800$ MHz. The same setups are used for assessment of the parameters applied for boundary compensation (alpha, depth) of which typical uncertainty values are given. These parameters are used in DASY4 software to improve probe accuracy close to the boundary. The sensitivity in TSL corresponds to NORM_{x,y,z} * ConvF whereby the uncertainty corresponds to that given for ConvF. A frequency dependent ConvF is used in DASY version 4.4 and higher which allows extending the validity from ± 50 MHz to ± 100 MHz.
- Spherical isotropy (3D deviation from isotropy)**: in a field of low gradients realized using a flat phantom exposed by a patch antenna.
- Sensor Offset**: The sensor offset corresponds to the offset of virtual measurement center from the probe tip (on probe axis). No tolerance required.

Probe ES3DV3

SN:3115

Manufactured:	March 6, 2006
Last calibrated:	January 19, 2010
Recalibrated:	January 12, 2011

Calibrated for DASY/EASY Systems

(Note: non-compatible with DASY2 system!)

DASY/EASY - Parameters of Probe: ES3DV3 SN:3115

Basic Calibration Parameters

	Sensor X	Sensor Y	Sensor Z	Unc (k=2)
Norm ($\mu\text{V}/(\text{V}/\text{m})^2$) ^A	1.29	1.30	1.18	± 10.1%
DCP (mV) ^B	100.2	102.3	101.3	

Modulation Calibration Parameters

UID	Communication System Name	PAR		A dB	B dBuV	C	VR mV	Unc ^E (k=2)
10000	CW	0.00	X	0.00	0.00	1.00	113.4	± 2.4 %
			Y	0.00	0.00	1.00	150.5	
			Z	0.00	0.00	1.00	142.6	

The reported uncertainty of measurement is stated as the standard uncertainty of measurement multiplied by the coverage factor k=2, which for a normal distribution corresponds to a coverage probability of approximately 95%.

^A The uncertainties of NormX,Y,Z do not affect the E²-field uncertainty inside TSL (see Pages 5 and 6).

^B Numerical linearization parameter: uncertainty not required.

^E Uncertainty is determined using the maximum deviation from linear response applying recatangular distribution and is expressed for the square of the field value.

DASY/EASY - Parameters of Probe: ES3DV3 SN:3115

Calibration Parameter Determined in Head Tissue Simulating Media

f [MHz]	Validity [MHz] ^c	Permittivity	Conductivity	ConvF X	ConvF Y	ConvF Z	Alpha	Depth Unc (k=2)
835	± 50 / ± 100	41.5 ± 5%	0.90 ± 5%	5.87	5.87	5.87	0.34	1.74 ± 11.0%
1810	± 50 / ± 100	40.0 ± 5%	1.40 ± 5%	5.02	5.02	5.02	0.43	1.62 ± 11.0%
1950	± 50 / ± 100	40.0 ± 5%	1.40 ± 5%	4.80	4.80	4.80	0.62	1.36 ± 11.0%
2450	± 50 / ± 100	39.2 ± 5%	1.80 ± 5%	4.39	4.39	4.39	0.94	1.13 ± 11.0%

^c The validity of ± 100 MHz only applies for DASY v4.4 and higher (see Page 2). The uncertainty is the RSS of the ConvF uncertainty at calibration frequency and the uncertainty for the indicated frequency band.

DASY/EASY - Parameters of Probe: ES3DV3 SN:3115

Calibration Parameter Determined in Body Tissue Simulating Media

f [MHz]	Validity [MHz] ^c	Permittivity	Conductivity	ConvF X	ConvF Y	ConvF Z	Alpha	Depth Unc (k=2)
835	± 50 / ± 100	55.2 ± 5%	0.97 ± 5%	5.88	5.88	5.88	0.57	1.41 ± 11.0%
1810	± 50 / ± 100	53.3 ± 5%	1.52 ± 5%	4.61	4.61	4.61	0.33	2.26 ± 11.0%
1950	± 50 / ± 100	53.3 ± 5%	1.52 ± 5%	4.57	4.57	4.57	0.36	2.19 ± 11.0%
2450	± 50 / ± 100	52.7 ± 5%	1.95 ± 5%	4.12	4.12	4.12	0.99	0.75 ± 11.0%

^c The validity of ± 100 MHz only applies for DASY v4.4 and higher (see Page 2). The uncertainty is the RSS of the ConvF uncertainty at calibration frequency and the uncertainty for the indicated frequency band.

Frequency Response of E-Field

(TEM-Cell:ifi110 EXX, Waveguide: R22)

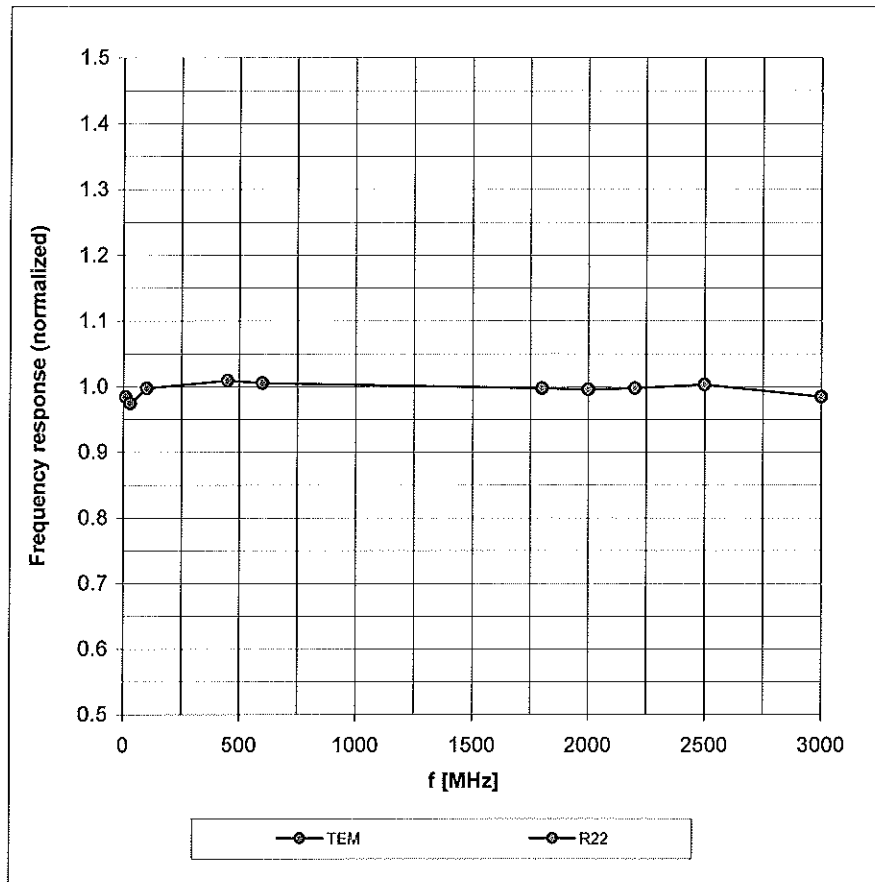

Uncertainty of Frequency Response of E-field: $\pm 6.3\%$ ($k=2$)

Receiving Pattern (ϕ), $\vartheta = 0^\circ$

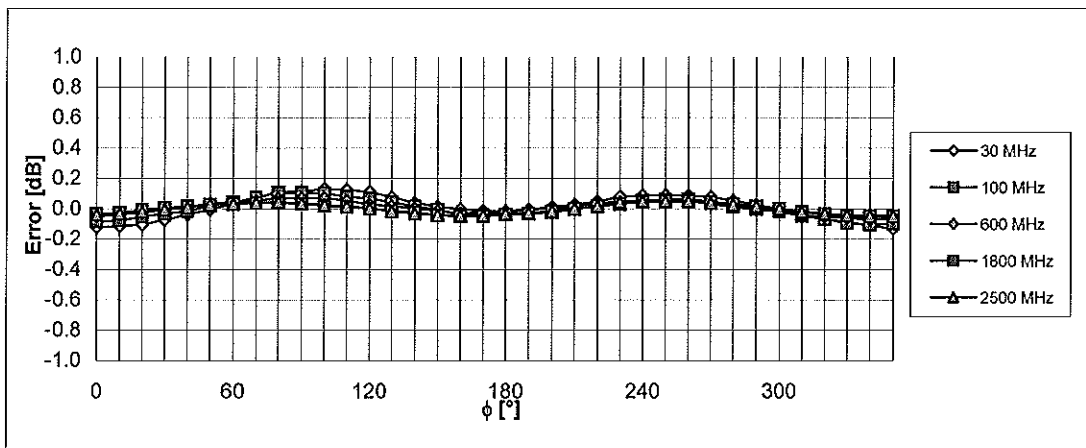
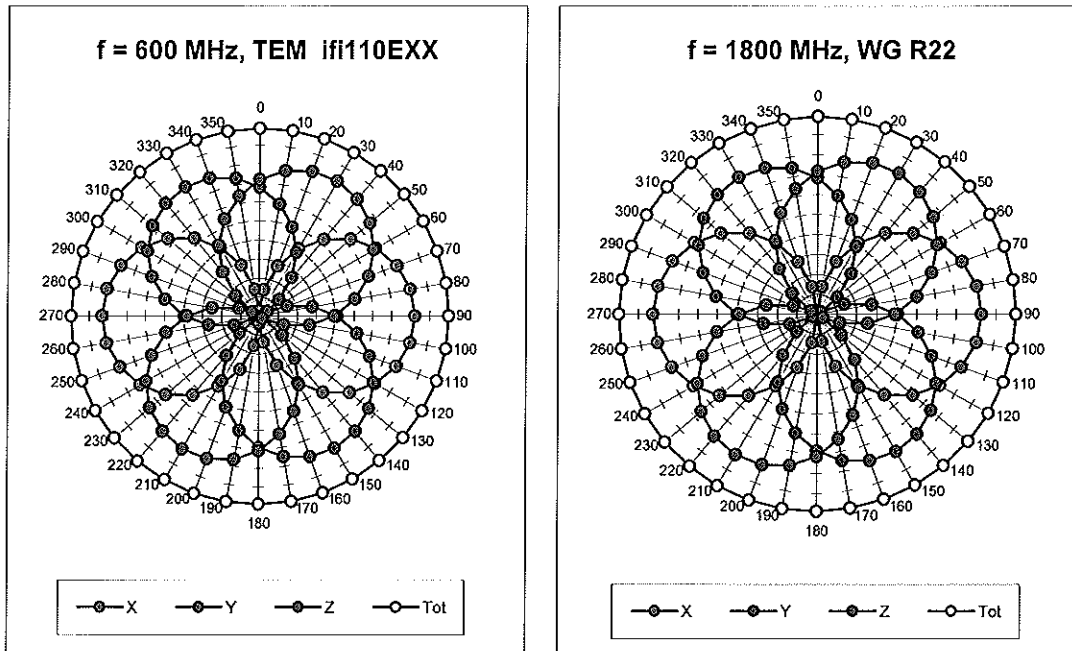

Uncertainty of Axial Isotropy Assessment: $\pm 0.5\%$ ($k=2$)

Dynamic Range f(SAR_{head}) (TEM cell, f = 900 MHz)

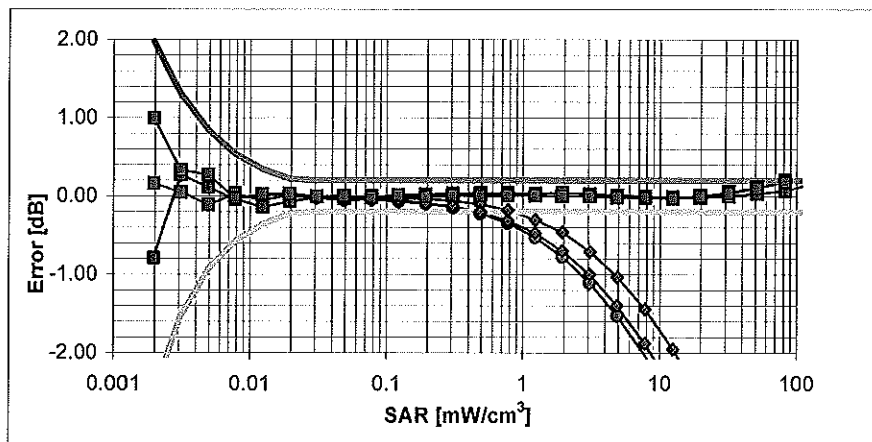
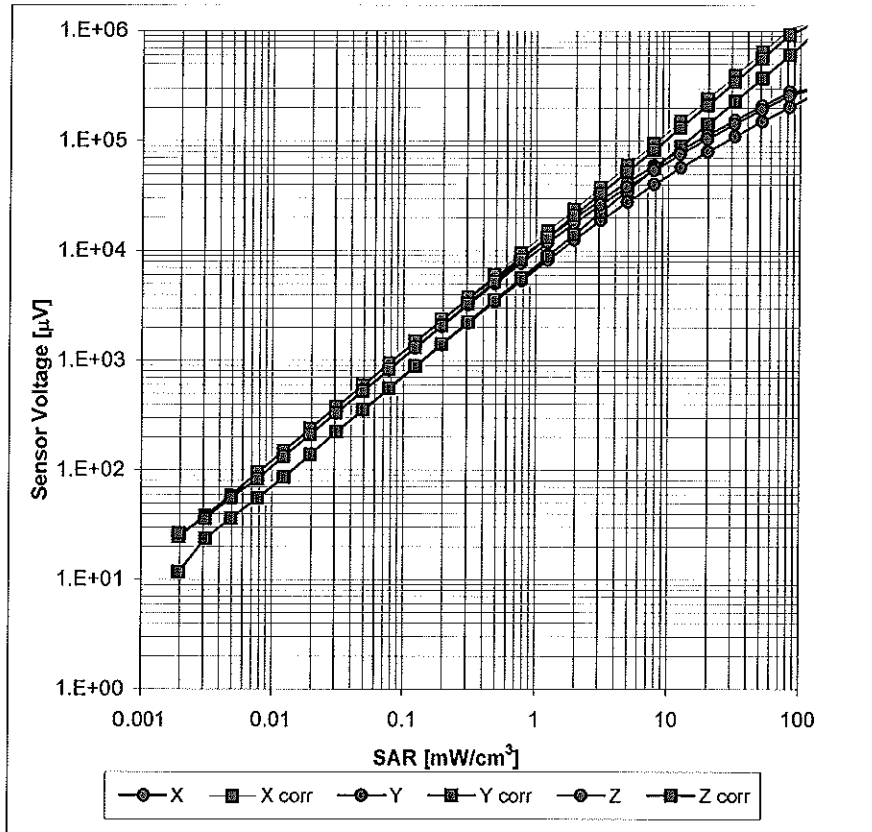

Uncertainty of Linearity Assessment: $\pm 0.6\%$ (k=2)

Conversion Factor Assessment

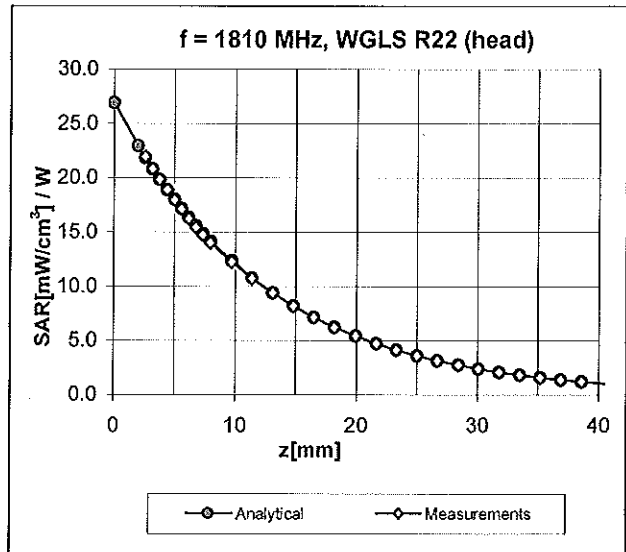
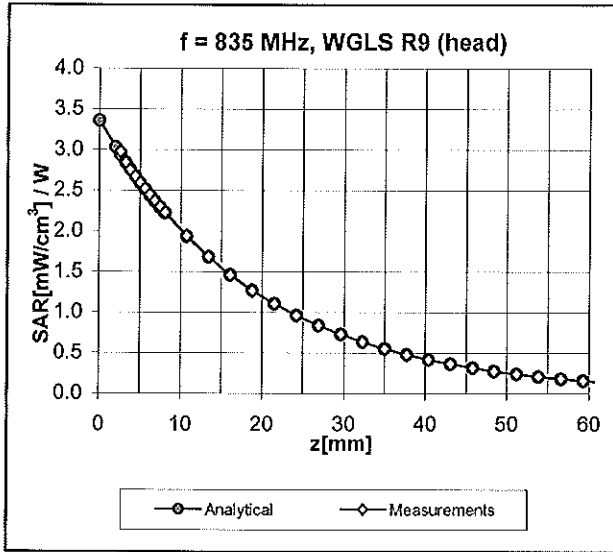

Deviation from Isotropy in HSL

Error (ϕ , θ), f = 900 MHz

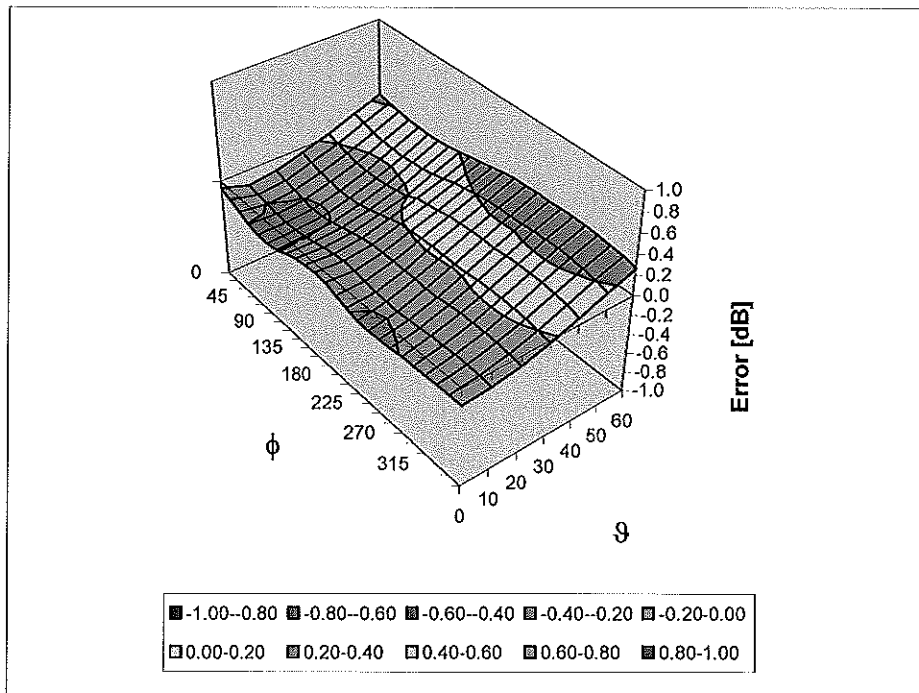

Uncertainty of Spherical Isotropy Assessment: $\pm 2.6\%$ (k=2)

Other Probe Parameters

Sensor Arrangement	Triangular
Connector Angle (°)	Not applicable
Mechanical Surface Detection Mode	enabled
Optical Surface Detection Mode	disabled
Probe Overall Length	337 mm
Probe Body Diameter	10 mm
Tip Length	10 mm
Tip Diameter	4 mm
Probe Tip to Sensor X Calibration Point	2 mm
Probe Tip to Sensor Y Calibration Point	2 mm
Probe Tip to Sensor Z Calibration Point	2 mm
Recommended Measurement Distance from Surface	3 mm



Accredited by the Swiss Accreditation Service (SAS)
The Swiss Accreditation Service is one of the signatories to the EA
Multilateral Agreement for the recognition of calibration certificates

Accreditation No.: **SCS 108**

Client **Motorola MDB**

Certificate No: **ES3-3037_Apr11/2**

CALIBRATION CERTIFICATE (Replacement of No: ES3-3037_Apr11)

Object **ES3DV3 - SN:3037**

Calibration procedure(s) **QA CAL-01.v7, QA CAL-23.v4, QA CAL-25.v3
Calibration procedure for dosimetric E-field probes**

Calibration date: **April 13, 2011**

This calibration certificate documents the traceability to national standards, which realize the physical units of measurements (SI).
The measurements and the uncertainties with confidence probability are given on the following pages and are part of the certificate.

All calibrations have been conducted in the closed laboratory facility: environment temperature (22 ± 3)°C and humidity < 70%.

Calibration Equipment used (M&TE critical for calibration)

Primary Standards	ID	Cal Date (Certificate No.)	Scheduled Calibration
Power meter E4419B	GB41293874	31-Mar-11 (No. 217-01372)	Apr-12
Power sensor E4412A	MY41495277	31-Mar-11 (No. 217-01372)	Apr-12
Power sensor E4412A	MY41498087	31-Mar-11 (No. 217-01372)	Apr-12
Reference 3 dB Attenuator	SN: S5054 (3c)	29-Mar-11 (No. 217-01369)	Apr-12
Reference 20 dB Attenuator	SN: S5086 (20b)	29-Mar-11 (No. 217-01367)	Apr-12
Reference 30 dB Attenuator	SN: S5129 (30b)	29-Mar-11 (No. 217-01370)	Apr-12
Reference Probe ES3DV2	SN: 3013	29-Dec-10 (No. ES3-3013_Dec10)	Dec-11
DAE4	SN: 854	23-Apr-10 (No. DAE4-854_Apr10)	Apr-11
Secondary Standards	ID	Check Date (in house)	Scheduled Check
RF generator HP 8648C	US3842U01700	4-Aug-99 (in house check Oct-09)	In house check: Oct-11
Network Analyzer HP 8753E	US37390585	18-Oct-01 (in house check Oct-10)	In house check: Oct-11

	Name	Function	Signature
Calibrated by:	Claudio Leubler	Laboratory Technician	
Approved by:	Kalja Pokovic	Technical Manager	

Issued: July 28, 2011

This calibration certificate shall not be reproduced except in full without written approval of the laboratory.



Accredited by the Swiss Accreditation Service (SAS)
The Swiss Accreditation Service is one of the signatories to the EA
Multilateral Agreement for the recognition of calibration certificates

Accreditation No.: SCS 108

Glossary:

TSL	tissue simulating liquid
NORM _{x,y,z}	sensitivity in free space
ConvF	sensitivity in TSL / NORM _{x,y,z}
DCP	diode compression point
CF	crest factor (1/duty_cycle) of the RF signal
A, B, C	modulation dependent linearization parameters
Polarization φ	φ rotation around probe axis
Polarization ϑ	ϑ rotation around an axis that is in the plane normal to probe axis (at measurement center), i.e., $\vartheta = 0$ is normal to probe axis

Calibration is Performed According to the Following Standards:

- IEEE Std 1528-2003, "IEEE Recommended Practice for Determining the Peak Spatial-Averaged Specific Absorption Rate (SAR) in the Human Head from Wireless Communications Devices: Measurement Techniques", December 2003
- IEC 62209-1, "Procedure to measure the Specific Absorption Rate (SAR) for hand-held devices used in close proximity to the ear (frequency range of 300 MHz to 3 GHz)", February 2005

Methods Applied and Interpretation of Parameters:

- NORM_{x,y,z}**: Assessed for E-field polarization $\vartheta = 0$ ($f \leq 900$ MHz in TEM-cell; $f > 1800$ MHz: R22 waveguide). NORM_{x,y,z} are only intermediate values, i.e., the uncertainties of NORM_{x,y,z} does not affect the E²-field uncertainty inside TSL (see below ConvF).
- NORM(f)_{x,y,z} = NORM_{x,y,z} * frequency_response** (see Frequency Response Chart). This linearization is implemented in DASY4 software versions later than 4.2. The uncertainty of the frequency response is included in the stated uncertainty of ConvF.
- DCP_{x,y,z}**: DCP are numerical linearization parameters assessed based on the data of power sweep with CW signal (no uncertainty required). DCP does not depend on frequency nor media.
- PAR**: PAR is the Peak to Average Ratio that is not calibrated but determined based on the signal characteristics
- A_{x,y,z}; B_{x,y,z}; C_{x,y,z}; VR_{x,y,z}; A, B, C** are numerical linearization parameters assessed based on the data of power sweep for specific modulation signal. The parameters do not depend on frequency nor media. VR is the maximum calibration range expressed in RMS voltage across the diode.
- ConvF and Boundary Effect Parameters**: Assessed in flat phantom using E-field (or Temperature Transfer Standard for $f \leq 800$ MHz) and inside waveguide using analytical field distributions based on power measurements for $f > 800$ MHz. The same setups are used for assessment of the parameters applied for boundary compensation (alpha, depth) of which typical uncertainty values are given. These parameters are used in DASY4 software to improve probe accuracy close to the boundary. The sensitivity in TSL corresponds to NORM_{x,y,z} * ConvF whereby the uncertainty corresponds to that given for ConvF. A frequency dependent ConvF is used in DASY version 4.4 and higher which allows extending the validity from ± 50 MHz to ± 100 MHz.
- Spherical isotropy (3D deviation from isotropy)**: in a field of low gradients realized using a flat phantom exposed by a patch antenna.
- Sensor Offset**: The sensor offset corresponds to the offset of virtual measurement center from the probe tip (on probe axis). No tolerance required.

Probe ES3DV3

SN:3037

Manufactured: August 21, 2003
Calibrated: April 13, 2011

Calibrated for DASYS/EASY Systems
(Note: non-compatible with DASYS2 system!)

DASY/EASY - Parameters of Probe: ES3DV3 - SN:3037

Basic Calibration Parameters

	Sensor X	Sensor Y	Sensor Z	Unc (k=2)
Norm ($\mu\text{V}/(\text{V}/\text{m})^2$) ^A	1.14	0.85	0.97	$\pm 10.1 \%$
DCP (mV) ^B	106.0	104.5	103.5	

Modulation Calibration Parameters

UID	Communication System Name	PAR		A dB	B dB	C dB	VR mV	Unc ^C (k=2)
10000	CW	0.00	X	0.00	0.00	1.00	146.0	$\pm 2.5 \%$
			Y	0.00	0.00	1.00	119.8	
			Z	0.00	0.00	1.00	129.2	

The reported uncertainty of measurement is stated as the standard uncertainty of measurement multiplied by the coverage factor $k=2$, which for a normal distribution corresponds to a coverage probability of approximately 95%.

^A The uncertainties of NormX,Y,Z do not affect the E²-field uncertainty inside TSL (see Pages 5 and 6).

^B Numerical linearization parameter: uncertainty not required.

^C Uncertainty is determined using the max. deviation from linear response applying rectangular distribution and is expressed for the square of the field value.

DASY/EASY - Parameters of Probe: ES3DV3 - SN:3037

Calibration Parameter Determined in Head Tissue Simulating Media

f (MHz) ^c	Relative Permittivity ^f	Conductivity (S/m) ^f	ConvF X	ConvF Y	ConvF Z	Alpha	Depth (mm)	Unct. (k=2)
835	41.5	0.90	6.15	6.15	6.15	0.98	1.08	± 12.0 %
1810	40.0	1.40	5.28	5.28	5.28	0.64	1.47	± 12.0 %
1950	40.0	1.40	5.02	5.02	5.02	0.69	1.34	± 12.0 %
2450	39.2	1.80	4.51	4.51	4.51	0.65	1.36	± 12.0 %

^c Frequency validity of ± 100 MHz only applies for DASY v4.4 and higher (see Page 2), else it is restricted to ± 50 MHz. The uncertainty is the RSS of the ConvF uncertainty at calibration frequency and the uncertainty for the indicated frequency band.

^f At frequencies below 3 GHz, the validity of tissue parameters (ϵ and σ) can be relaxed to ± 10% if liquid compensation formula is applied to measured SAR values. At frequencies above 3 GHz, the validity of tissue parameters (ϵ and σ) is restricted to ± 5%. The uncertainty is the RSS of the ConvF uncertainty for indicated target tissue parameters.

DASY/EASY - Parameters of Probe: ES3DV3- SN:3037

Calibration Parameter Determined in Body Tissue Simulating Media

f (MHz) ^c	Relative Permittivity ^f	Conductivity (S/m) ^f	ConvF X	ConvF Y	ConvF Z	Alpha	Depth (mm)	Unct. (k=2)
835	55.2	0.97	6.08	6.08	6.08	1.00	1.10	± 12.0 %
1810	53.3	1.52	4.88	4.88	4.88	0.68	1.22	± 12.0 %
1950	53.3	1.52	4.81	4.81	4.81	0.80	1.25	± 12.0 %
2450	52.7	1.95	4.24	4.24	4.24	0.79	1.18	± 12.0 %

^c Frequency validity of ± 100 MHz only applies for DASY v4.4 and higher (see Page 2), else it is restricted to ± 50 MHz. The uncertainty is the RSS of the ConvF uncertainty at calibration frequency and the uncertainty for the indicated frequency band.

^f At frequencies below 3 GHz, the validity of tissue parameters (ϵ and σ) can be relaxed to ± 10% if liquid compensation formula is applied to measured SAR values. At frequencies above 3 GHz, the validity of tissue parameters (ϵ and σ) is restricted to ± 5%. The uncertainty is the RSS of the ConvF uncertainty for indicated target tissue parameters.

Frequency Response of E-Field (TEM-Cell:ifi110 EXX, Waveguide: R22)

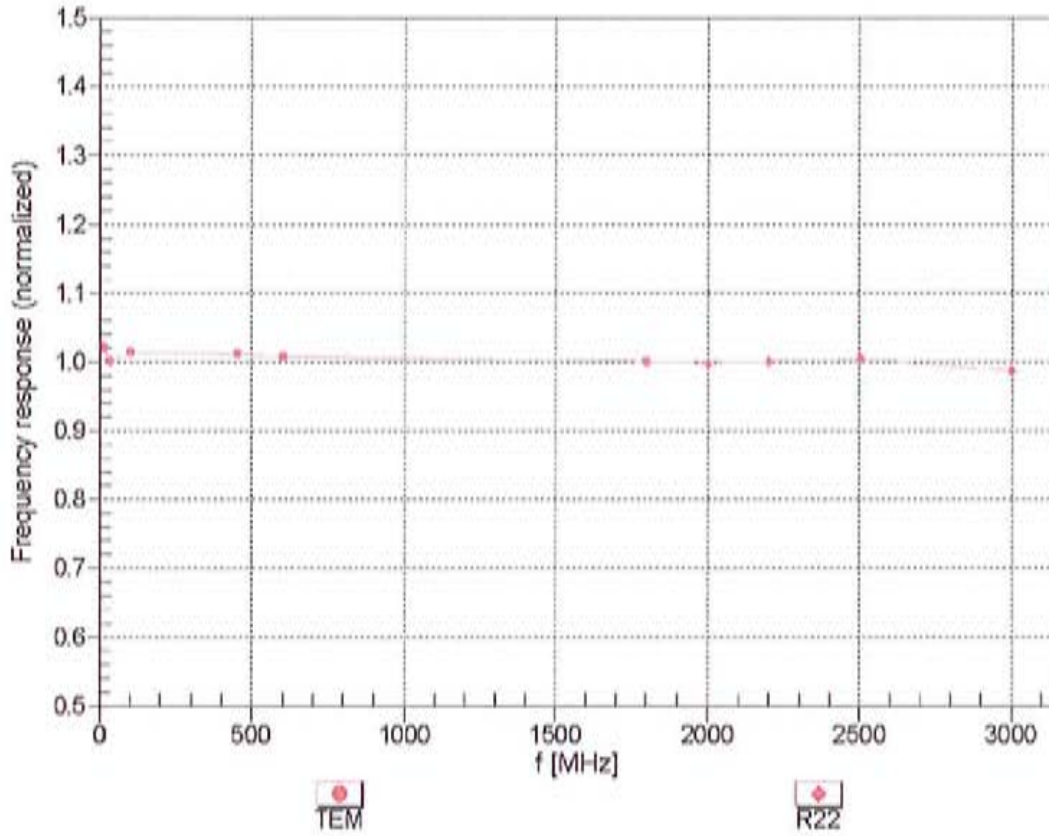

Uncertainty of Frequency Response of E-field: $\pm 6.3\%$ (k=2)

Receiving Pattern (ϕ), $\vartheta = 0^\circ$

f=600 MHz,TEM

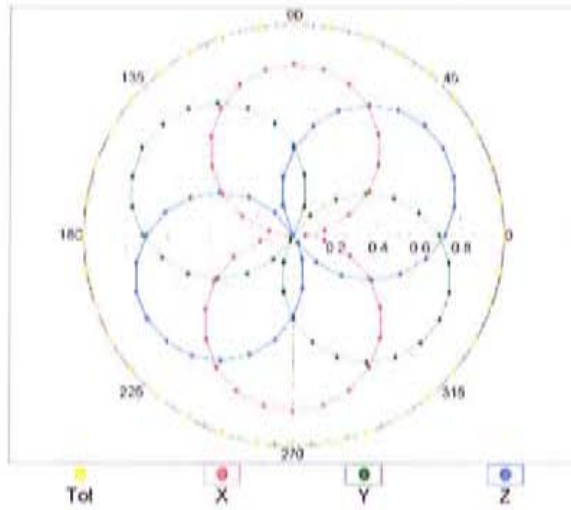

f=1800 MHz,R22

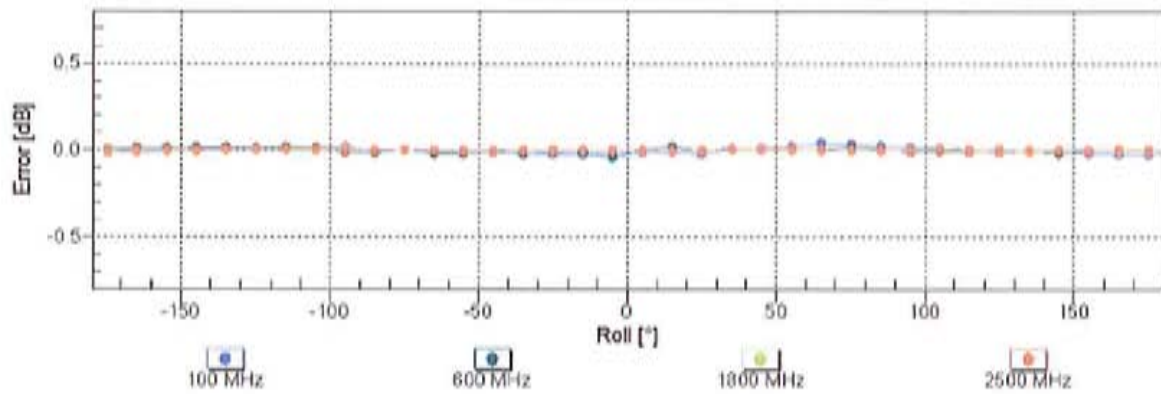
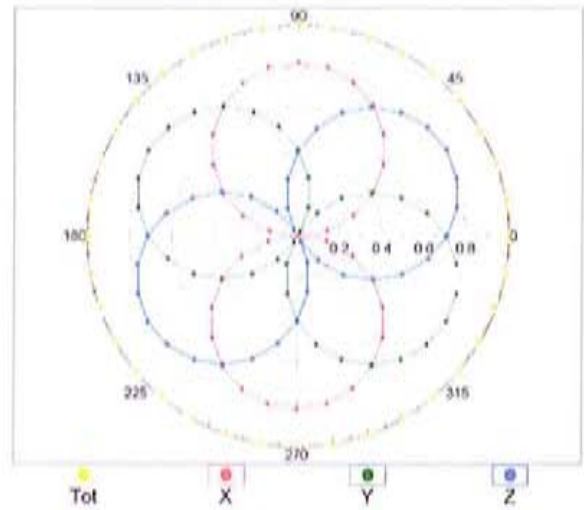

Uncertainty of Axial Isotropy Assessment: $\pm 0.5\%$ (k=2)

Dynamic Range f(SAR_{head}) (TEM cell, f = 900 MHz)

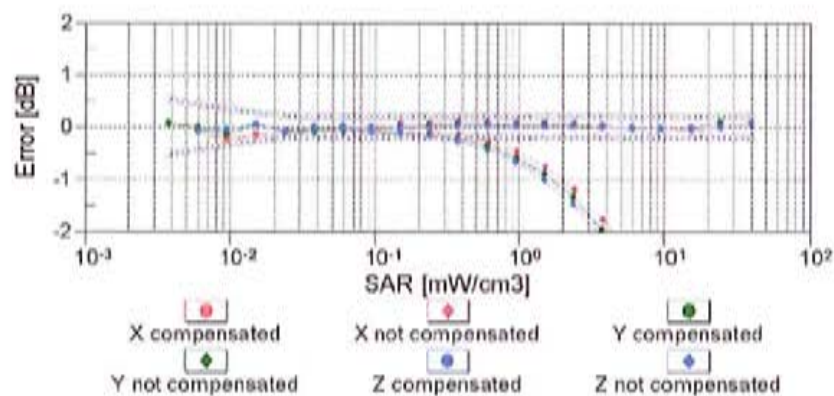
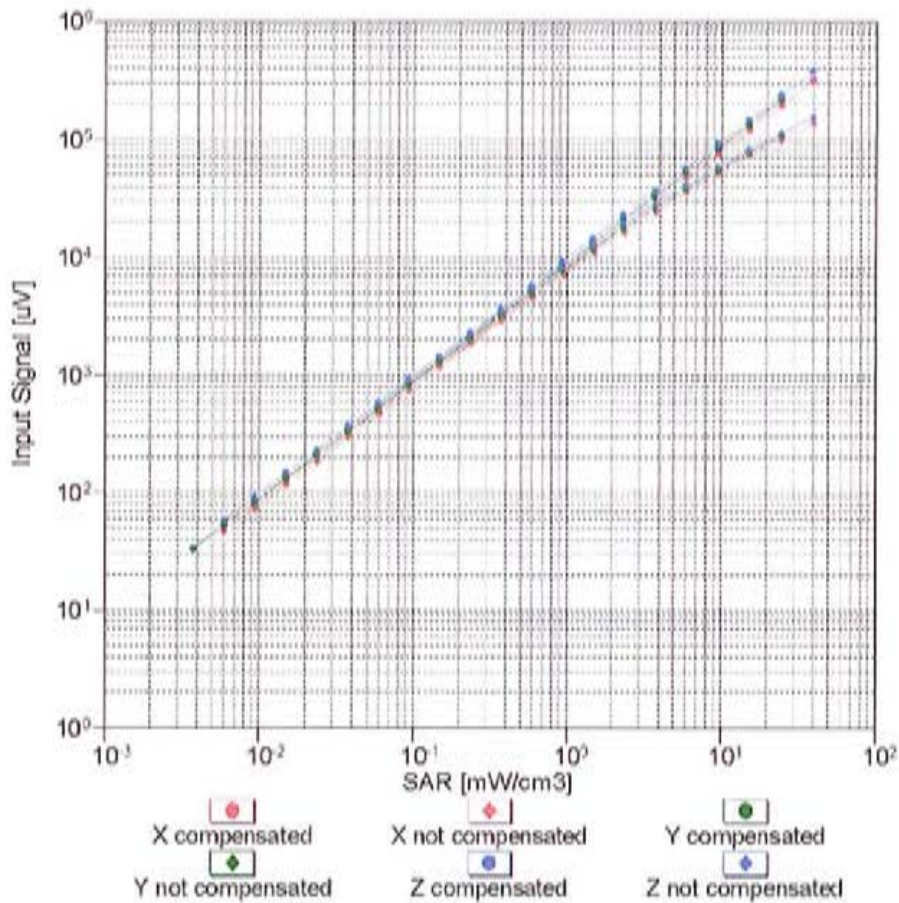

Uncertainty of Linearity Assessment: ± 0.6% (k=2)

Conversion Factor Assessment

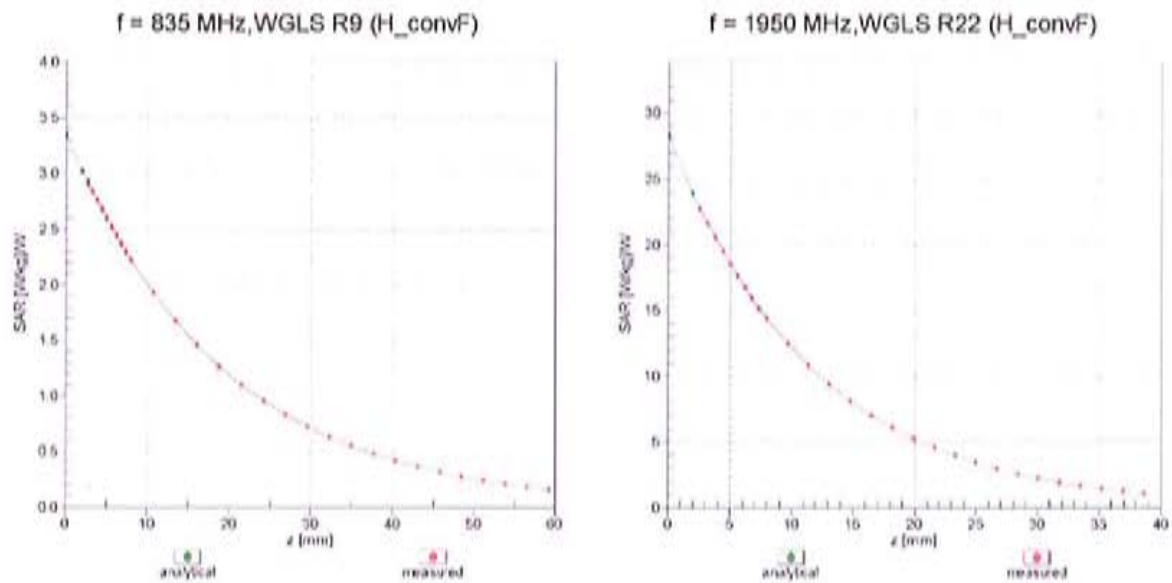

Deviation from Isotropy in Liquid

Error (ϕ, θ), f = 900 MHz

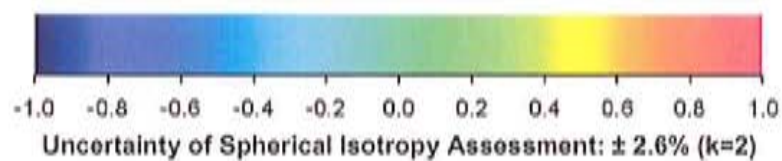
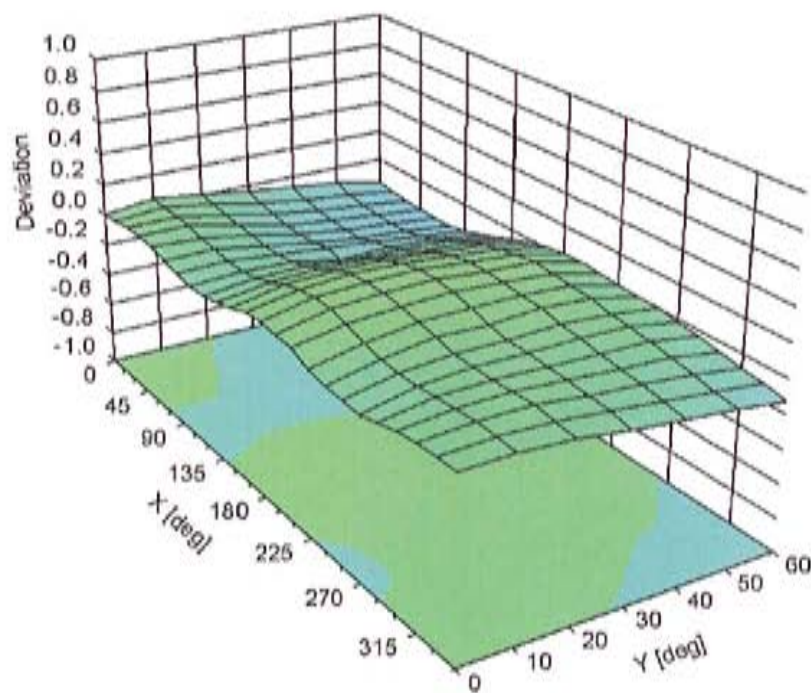

DASY/EASY - Parameters of Probe: ES3DV3 - SN:3037**Other Probe Parameters**

Sensor Arrangement	Triangular
Connector Angle (°)	Not applicable
Mechanical Surface Detection Mode	enabled
Optical Surface Detection Mode	disabled
Probe Overall Length	337 mm
Probe Body Diameter	10 mm
Tip Length	10 mm
Tip Diameter	4 mm
Probe Tip to Sensor X Calibration Point	2 mm
Probe Tip to Sensor Y Calibration Point	2 mm
Probe Tip to Sensor Z Calibration Point	2 mm
Recommended Measurement Distance from Surface	3 mm

Appendix 8

Dipole Characterization Certificate

END OF REPORT