

ANNEX E PROBE CALIBRATION CERTIFICATE

Calibration Laboratory of
Schmid & Partner
Engineering AG
Zeughausstrasse 43, 8004 Zurich, Switzerland



S Schweizerischer Kalibrierdienst
C Service suisse d'étalonnage
S Servizio svizzero di taratura
S Swiss Calibration Service

Accredited by the Swiss Accreditation Service (SAS)
The Swiss Accreditation Service is one of the signatories to the EA
Multilateral Agreement for the recognition of calibration certificates

Accreditation No.: **SCS 108**

Client **TMC China**

Certificate No: **ES3DV3-3149_Sep09**

CALIBRATION CERTIFICATE

Object	ES3DV3-SN: 3149
Calibration procedure(s)	QA CAL-01.v6 Calibration procedure for dosimetric E-field probes
Calibration date:	September 25, 2009
Condition of the calibrated item	In Tolerance

This calibration certify documents the traceability to national standards, which realize the physical units of measurements(SI).
The measurements and the uncertainties with confidence probability are given on the following pages and are part of the certificate.
All calibrations have been conducted at an environment temperature (22±3)°C and humidity<70%

Calibration Equipment used (M&TE critical for calibration)

Primary Standards	ID#	Cal Data (Calibrated by, Certification NO.)	Scheduled Calibration
Power meter E4419B	GB41293874	5-May-09 (METAS, NO. 251-00388)	May-10
Power sensor E4412A	MY41495277	5-May-09 (METAS, NO. 251-00388)	May-10
Reference 3 dB Attenuator	SN:S5054 (3c)	10-Aug-09 (METAS, NO. 251-00403)	Aug-10
Reference 20 dB Attenuator	SN:S5086 (20b)	3-May-09 (METAS, NO. 251-00389)	May-10
Reference 30 dB Attenuator	SN:S5129 (30b)	10-Aug-09 (METAS, NO. 251-00404)	Aug-10
DAE4	SN:617	10-Jun-09 (SPEAG, NO.DAE4-907_Jun09)	Jun-10
Reference Probe ES3DV2	SN: 3013	12-Jan-09 (SPEAG, NO. ES3-3013_Jan09)	Jan-10

Secondary Standards	ID#	Check Data (in house)	Scheduled Calibration
RF generator HP8648C	US3642U01700	4-Aug-99(SPEAG, in house check Oct-07)	In house check: Oct-09
Network Analyzer HP 8753E	US37390585	18-Oct-01(SPEAG, in house check Nov-07)	In house check: Nov-09

Name	Function	Signature
Calibrated by: Katja Pokovic	Technical Manager	

Approved by: Niels Kuster	Quality Manager	
---------------------------	-----------------	--------------------------------------------------------------------------------------

Issued: **September 25, 2009**

This calibration certificate shall not be reported except in full without written approval of the laboratory.

Calibration Laboratory of
Schmid & Partner
Engineering AG
Zeughausstrasse 43, 8004 Zurich, Switzerland



S Schweizerischer Kalibrierdienst
S Service suisse d'étalonnage
C Servizio svizzero di taratura
S Swiss Calibration Service

Accredited by the Swiss Accreditation Service (SAS)
The Swiss Accreditation Service is one of the signatories to the EA
Multilateral Agreement for the recognition of calibration certificates

Accreditation No.: **SCS 108**

Glossary:

TSL	tissue simulating liquid
NORM _{x,y,z}	sensitivity in free space
ConF	sensitivity in TSL / NORM _{x,y,z}
DCP	diode compression point
Polarization φ	φ rotation around probe axis
Polarization ϑ	ϑ rotation around an axis that is in the plane normal to probe axis (at measurement center), i.e., $\vartheta = 0$ is normal to probe axis

Calibration is Performed According to the Following Standards:

- a) IEEE Std 1528-2003, "IEEE Recommended Practice for Determining the Peak Spatial-Averaged Specific Absorption Rate (SAR) in the Human Head from Wireless Communications Devices: Measurement Techniques", December 2003
- b) IEC 62209-1, "Procedure to measure the Specific Absorption Rate (SAR) for hand-held devices used in close proximity to the ear (frequency range of 300 MHz to 3 GHz)", February 2005

Methods Applied and Interpretation of Parameters:

- **NORM_{x,y,z}**: Assessed for E-field polarization $\vartheta = 0$ ($f \leq 900$ MHz in TEM-cell; $f > 1800$ MHz: R22 waveguide). NORM_{x,y,z} are only intermediate values, i.e., the uncertainties of NORM_{x,y,z} does not effect the E²-field uncertainty inside TSL (see below *ConvF*).
- **NORM(f)_{x,y,z} = NORM_{x,y,z} * frequency_response** (see Frequency Response Chart). This linearization is implemented in DASY4 software versions later than 4.2. The uncertainty of the frequency response is included in the stated uncertainty of *ConvF*.
- **DCP_{x,y,z}**: DCP are numerical linearization parameters assessed based on the data of power sweep (no uncertainty required). DCP does not depend on frequency nor media.
- **ConvF and Boundary Effect Parameters**: Assessed in flat phantom using E-field (or Temperature Transfer Standard for $f \leq 800$ MHz) and inside waveguide using analytical field distributions based on power measurements for $f > 800$ MHz. The same setups are used for assessment of the parameters applied for boundary compensation (alpha, depth) of which typical uncertainty values are given. These parameters are used in DASY4 software to improve probe accuracy close to the boundary. The sensitivity in TSL corresponds to NORM_{x,y,z} * *ConvF* whereby the uncertainty corresponds to that given for *ConvF*. A frequency dependent *ConvF* is used in DASY version 4.4 and higher which allows extending the validity from ± 50 MHz to ± 100 MHz.
- **Spherical isotropy (3D deviation from isotropy)**: in a field of low gradients realized using a flat phantom exposed by a patch antenna.
- **Sensor Offset**: The sensor offset corresponds to the offset of virtual measurement center from the probe tip (on probe axis). No tolerance required.

ES3DV3 SN: 3149

September 25, 2009

Probe ES3DV3

SN: 3149

Manufactured: June 12, 2007

Calibrated: September 25, 2009

Calibrated for DASY4 System

ES3DV3 SN: 3149

September 25, 2009

DASY – Parameters of Probe: ES3DV3 SN:3149

Sensitivity in Free Space^A

Diode Compression^B

NormX	1.14±10.1%	$\mu V/(V/m)^2$	DCP X	94mV
NormY	1.23±10.1%	$\mu V/(V/m)^2$	DCP Y	95mV
NormZ	1.29±10.1%	$\mu V/(V/m)^2$	DCP Z	91mV

Sensitivity in Tissue Simulating Liquid (Conversion Factors)

Please see Page 8

Boundary Effect

TSL 900MHz Typical SAR gradient: 5% per mm

Sensor Center to Phantom Surface Distance		3.0 mm	4.0 mm
SARbe[%]	Without Correction Algorithm	3.8	1.6
SARbe[%]	With Correction Algorithm	0.8	0.7

TSL 1810MHz Typical SAR gradient: 10% per mm

Sensor Center to Phantom Surface Distance		3.0 mm	4.0 mm
SARbe[%]	Without Correction Algorithm	6.8	3.6
SARbe[%]	With Correction Algorithm	0.4	0.2

Sensor Offset

Probe Tip to Sensor Center 2.0 mm

The reported uncertainty of measurement is stated as the standard uncertainty of Measurement multiplied by the coverage factor $k=2$, which for a normal distribution Corresponds to a coverage probability of approximately 95%.

^A The uncertainties of NormX,Y,Z do not affect the E^2 -field uncertainty inside TSL (see Page 8).

^B Numerical linearization parameter: uncertainty not required.

ES3DV3 SN: 3149

September 25, 2009

Frequency Response of E-Field

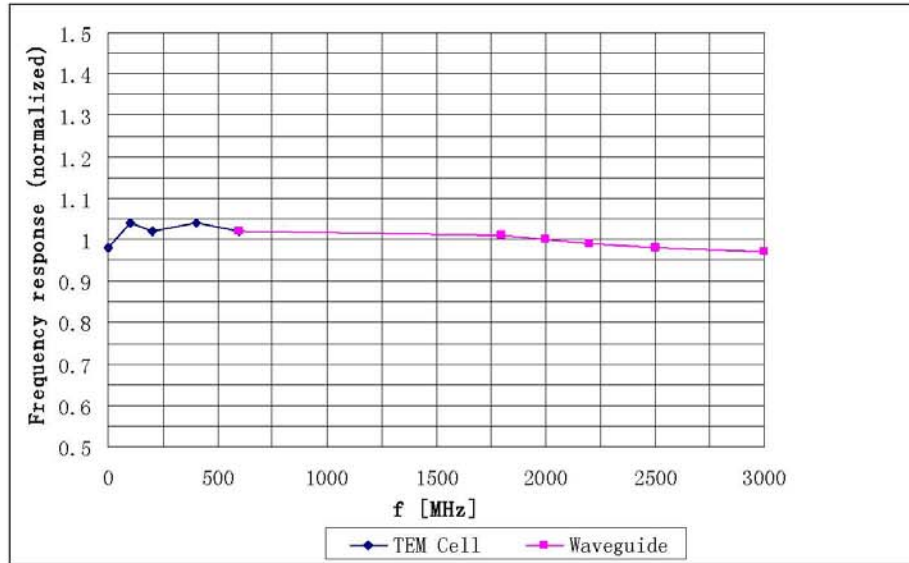

Uncertainty of Frequency Response of E-field: $\pm 5.0\%$ (k=2)

ES3DV3 SN: 3149

September 25, 2009

Receiving Pattern (ϕ), $\theta = 0^\circ$

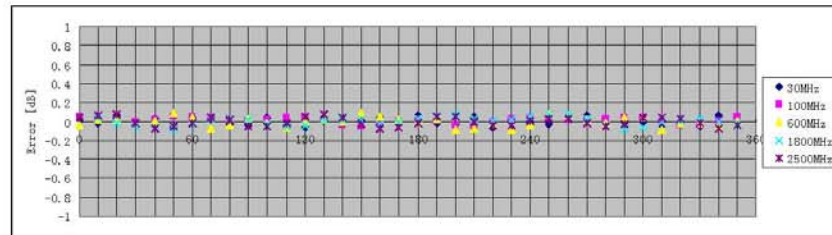
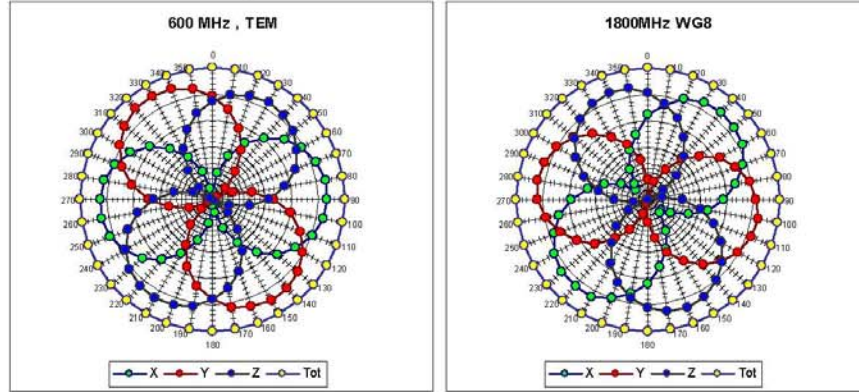

Uncertainty of Axial Isotropy Assessment: $\pm 0.5\%$ (k=2)

ES3DV3 SN: 3149

September 25, 2009

Dynamic Range f(SAR_{head}) (Waveguide: WG8, f= 1800 MHz)

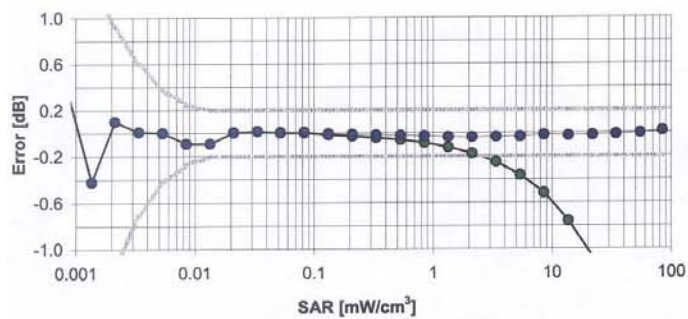
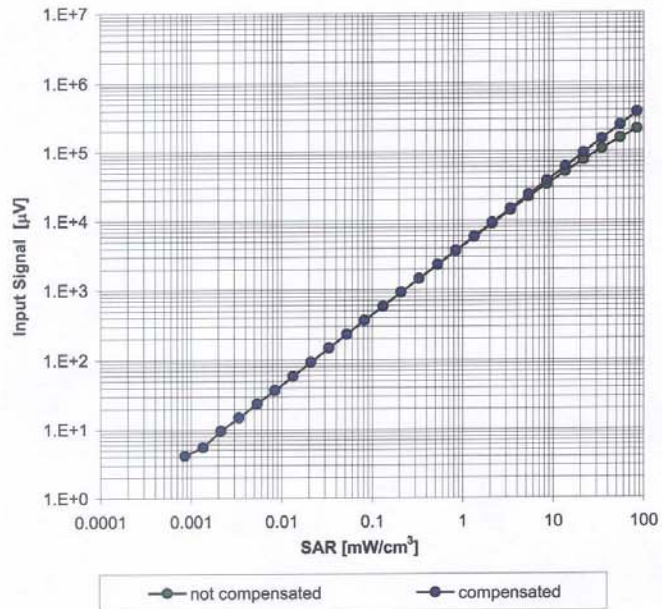

Uncertainty of Linearity Assessment: $\pm 0.5\%$ (k=2)

ES3DV3 SN: 3149

September 25, 2009

Conversion Factor Assessment

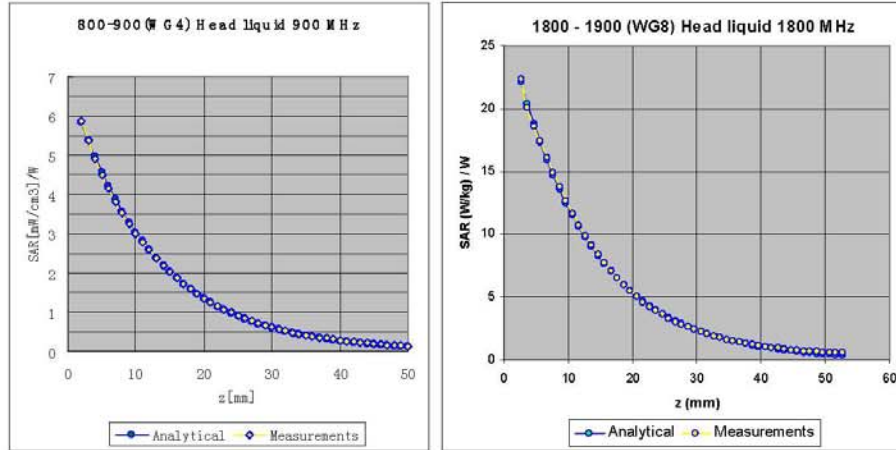

f[MHz]	Validity[MHz] ^C	TSL	Permittivity	Conductivity	Alpha	Depth	ConvF	Uncertainty
850	±50 /±100	Head	41.5±5%	0.90±5%	0.91	1.13	6.56	±11.0% (k=2)
900	±50 /±100	Head	41.5±5%	0.97±5%	0.83	1.26	6.34	±11.0% (k=2)
1800	±50 /±100	Head	40.0±5%	1.40±5%	0.69	1.47	5.18	±11.0% (k=2)
1900	±50 /±100	Head	40.0±5%	1.40±5%	0.72	1.38	5.03	±11.0% (k=2)
2100	±50 /±100	Head	39.8±5%	1.49±5%	0.66	1.34	4.58	±11.0% (k=2)
850	±50 /±100	Body	55.2±5%	0.97±5%	0.76	1.26	6.22	±11.0% (k=2)
900	±50 /±100	Body	55.0±5%	1.05±5%	0.99	1.06	6.02	±11.0% (k=2)
1800	±50 /±100	Body	53.3±5%	1.52±5%	0.75	1.34	4.97	±11.0% (k=2)
1900	±50 /±100	Body	53.3±5%	1.52±5%	0.62	1.33	4.68	±11.0% (k=2)
2100	±50 /±100	Body	53.5±5%	1.57±5%	0.68	1.34	4.35	±11.0% (k=2)

^C The validity of ±100 MHz only applies for DASY v4.4 and higher (see Page 2). The uncertainty is the RSS of the ConvF uncertainty at calibration frequency and the uncertainty for the indicated frequency band.

ES3DV3 SN: 3149

September 25, 2009

Deviation from Isotropy

Error (ϕ, θ), $f = 900$ MHz

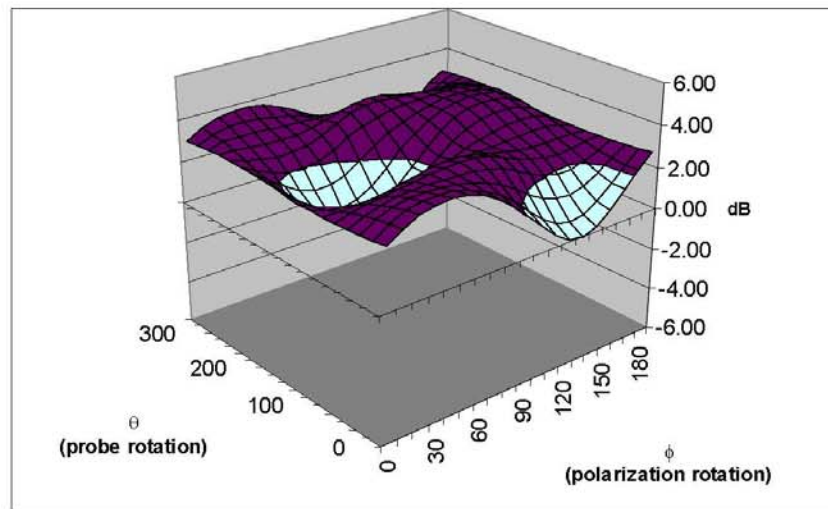

Uncertainty of Spherical Isotropy Assessment: $\pm 2.5\%$ ($k=2$)

**Calibration Laboratory of
Schmid & Partner
Engineering AG**
Zeughausstrasse 43, 8004 Zurich, Switzerland



S Schweizerischer Kalibrierdienst
C Service suisse d'étalonnage
S Servizio svizzero di taratura
S Swiss Calibration Service

Accredited by the Swiss Accreditation Service (SAS)
The Swiss Accreditation Service is one of the signatories to the EA
Multilateral Agreement for the recognition of calibration certificates

Accreditation No.: **SCS 108**

Client **TMC China**

Certificate No: **EX3DV4-3617_Jul10**

CALIBRATION CERTIFICATE

Object	EX3DV4-SN: 3617
Calibration procedure(s)	QA CAL-01.v6 Calibration procedure for dosimetric E-field probes
Calibration date:	July 9, 2010
Condition of the calibrated item	In Tolerance

This calibration certify documents the traceability to national standards, which realize the physical units of measurements(SI).
The measurements and the uncertainties with confidence probability are given on the following pages and are part of the certificate.
All calibrations have been conducted at an environment temperature (22±3)°C and humidity<70%

Calibration Equipment used (M&TE critical for calibration)

Primary Standards	ID#	Cal Data (Calibrated by, Certification NO.)	Scheduled Calibration
Power meter E4419B	GB41293874	6-May-10 (METAS, NO. 251-00388)	May-11
Power sensor E4412A	MY41495277	6-May-10 (METAS, NO. 251-00388)	May-11
Reference 3 dB Attenuator	SN:S5054 (3c)	12-Aug-09 (METAS, NO. 251-00403)	Aug-10
Reference 20 dB Attenuator	SN:S5086 (20b)	4-May-10 (METAS, NO. 251-00389)	May-11
Reference 30 dB Attenuator	SN:S5129 (30b)	12-Aug-09 (METAS, NO. 251-00404)	Aug-10
DAE4	SN:617	11-Jun-10 (SPEAG, NO.DAE4-907_Jun10)	Jun-11
Reference Probe ES3DV2	SN: 3013	13-Jan-10 (SPEAG, NO. ES3-3013_Jan10)	Jan-11

Secondary Standards	ID#	Check Data (in house)	Scheduled Calibration
RF generator HP8648C	US3642U01700	4-Aug-99(SPEAG, in house check Oct-09)	In house check: Oct-10
Network Analyzer HP 8753E	US37390585	18-Oct-01(SPEAG, in house check Nov-09)	In house check: Nov-10

Calibrated by:	Name	Function	Signature
	Katja Pokovic	Technical Manager	
Approved by:	Niels Kuster	Quality Manager	

Issued: July 9, 2010

This calibration certificate shall not be reported except in full without written approval of the laboratory.

Certificate No: **EX3DV4-3617_Jul10**

Page 1 of 9

Calibration Laboratory of
Schmid & Partner
Engineering AG
Zeughausstrasse 43, 8004 Zurich, Switzerland



S Schweizerischer Kalibrierdienst
S Service suisse d'étalonnage
C Servizio svizzero di taratura
S Swiss Calibration Service

Accredited by the Swiss Accreditation Service (SAS)
The Swiss Accreditation Service is one of the signatories to the EA
Multilateral Agreement for the recognition of calibration certificates

Accreditation No.: SCS 108

Glossary:

TSL	tissue simulating liquid
NORM _{x,y,z}	sensitivity in free space
ConF	sensitivity in TSL / NORM _{x,y,z}
DCP	diode compression point
Polarization ϕ	ϕ rotation around probe axis
Polarization ϑ	ϑ rotation around an axis that is in the plane normal to probe axis (at measurement center), i.e., $\vartheta = 0$ is normal to probe axis

Calibration is Performed According to the Following Standards:

- a) IEEE Std 1528-2003, "IEEE Recommended Practice for Determining the Peak Spatial-Averaged Specific Absorption Rate (SAR) in the Human Head from Wireless Communications Devices: Measurement Techniques", December 2003
- b) IEC 62209-1, "Procedure to measure the Specific Absorption Rate (SAR) for hand-held devices used in close proximity to the ear (frequency range of 300 MHz to 3 GHz)", February 2005

Methods Applied and Interpretation of Parameters:

- **NORM_{x,y,z}**: Assessed for E-field polarization $\vartheta = 0$ ($f \leq 900$ MHz in TEM-cell; $f > 1800$ MHz: R22 waveguide). NORM_{x,y,z} are only intermediate values, i.e., the uncertainties of NORM_{x,y,z} does not effect the E²-field uncertainty inside TSL (see below *ConvF*).
- **NORM(f)_{x,y,z}** = NORM_{x,y,z} * frequency_response (see Frequency Response Chart). This linearization is implemented in DASY4 software versions later than 4.2. The uncertainty of the frequency response is included in the stated uncertainty of *ConvF*.
- **DCP_{x,y,z}**: DCP are numerical linearization parameters assessed based on the data of power sweep (no uncertainty required). DCP does not depend on frequency nor media.
- **ConvF and Boundary Effect Parameters**: Assessed in flat phantom using E-field (or Temperature Transfer Standard for $f \leq 800$ MHz) and inside waveguide using analytical field distributions based on power measurements for $f > 800$ MHz. The same setups are used for assessment of the parameters applied for boundary compensation (alpha, depth) of which typical uncertainty values are given. These parameters are used in DASY4 software to improve probe accuracy close to the boundary. The sensitivity in TSL corresponds to NORM_{x,y,z} * *ConvF* whereby the uncertainty corresponds to that given for *ConvF*. A frequency dependent *ConvF* is used in DASY version 4.4 and higher which allows extending the validity from ± 50 MHz to ± 100 MHz.
- **Spherical isotropy (3D deviation from isotropy)**: in a field of low gradients realized using a flat phantom exposed by a patch antenna.
- **Sensor Offset**: The sensor offset corresponds to the offset of virtual measurement center from the probe tip (on probe axis). No tolerance required.

EX3DV4 SN: 3617

July 9, 2010

Probe EX3DV4

SN: 3617

Manufactured: May 3, 2007

Calibrated: July 9, 2010

Calibrated for DASY4 System

EX3DV4 SN: 3617

July 9, 2010

Frequency Response of E-Field

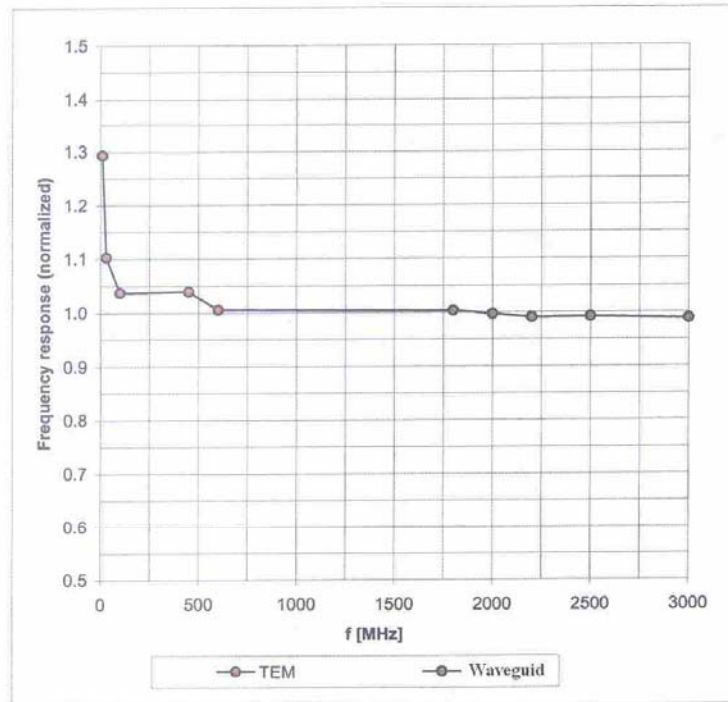

Uncertainty of Frequency Response of E-field: $\pm 6.3\%$ (k=2)

EX3DV4 SN: 3617

July 9, 2010

Receiving Pattern (ϕ), $\theta = 0^\circ$

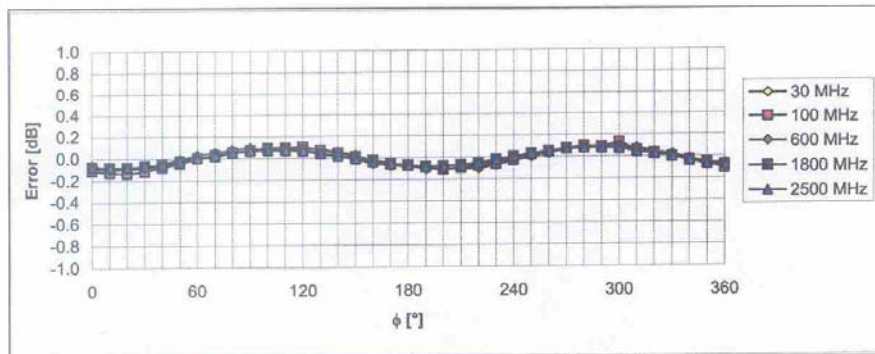
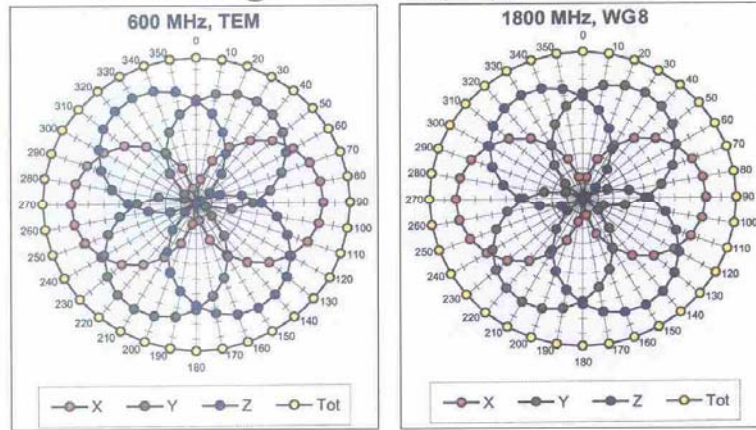

Uncertainty of Axial Isotropy Assessment: $\pm 0.5\%$ ($k=2$)

EX3DV4 SN: 3617

July 9, 2010

Dynamic Range $f(SAR_{head})$ (Waveguide: WG8, $f = 1800$ MHz)

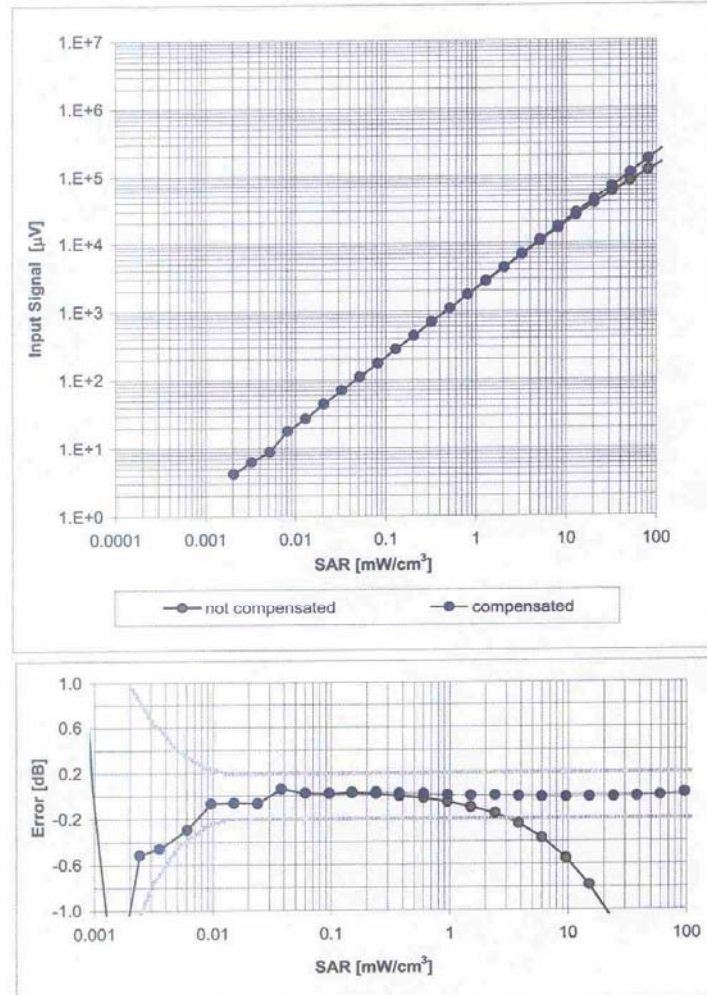

Uncertainty of Linearity Assessment: $\pm 0.6\%$ ($k=2$)

EX3DV4 SN: 3617

July 9, 2010

Conversion Factor Assessment

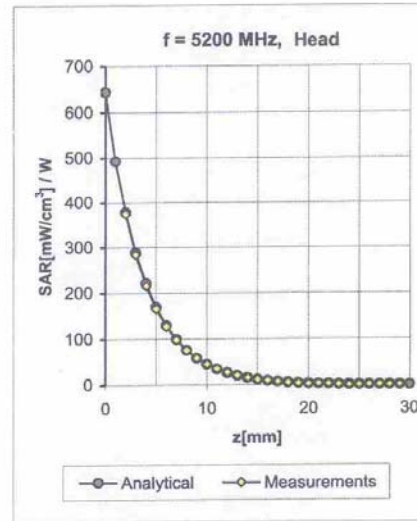
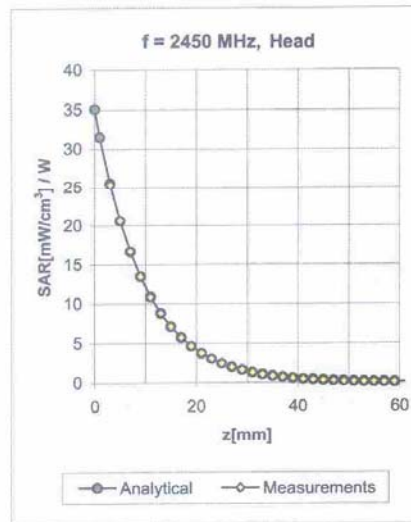

f [MHz]	Validity [MHz] ^C	TSL	Permittivity	Conductivity	Alpha	Depth	ConvF	Uncertainty
2300	±50 / ±100	Head	39.5 ± 5%	1.67 ± 5%	0.33	1.02	7.23	±11.8% (k=2)
2450	±50 / ±100	Head	39.2 ± 5%	1.80 ± 5%	0.33	1.00	7.19	±11.8% (k=2)
2600	±50 / ±100	Head	39.0 ± 5%	1.96 ± 5%	0.36	1.21	7.16	±11.8% (k=2)
5200	±50 / ±100	Head	36.0 ± 5%	4.66 ± 5%	0.35	1.60	5.33	±13.1% (k=2)
5800	±50 / ±100	Head	35.3 ± 5%	5.27 ± 5%	0.35	1.60	4.69	±13.1% (k=2)
2300	±50 / ±100	Body	52.8 ± 5%	1.85 ± 5%	0.30	1.01	6.95	±11.8% (k=2)
2450	±50 / ±100	Body	52.7 ± 5%	1.95 ± 5%	0.36	1.00	6.88	±11.8% (k=2)
2600	±50 / ±100	Body	52.5 ± 5%	2.16 ± 5%	0.36	1.05	6.84	±11.8% (k=2)
3500	±50 / ±100	Body	51.3 ± 5%	3.30 ± 5%	0.33	1.40	5.02	±11.8% (k=2)
5200	±50 / ±100	Body	49.0 ± 5%	5.30 ± 5%	0.35	1.70	4.64	±13.1% (k=2)
5800	±50 / ±100	Body	48.2 ± 5%	6.00 ± 5%	0.30	1.70	4.53	±13.1% (k=2)

^C The validity of ±100 MHz only applies for DASY v4.4 and higher (see Page 2). The uncertainty is the RSS of the ConvF uncertainty at calibration frequency and the uncertainty for the indicated frequency band.

EX3DV4 SN: 3617

July 9, 2010

Deviation from Isotropy

Error (ϕ, θ), $f = 900$ MHz

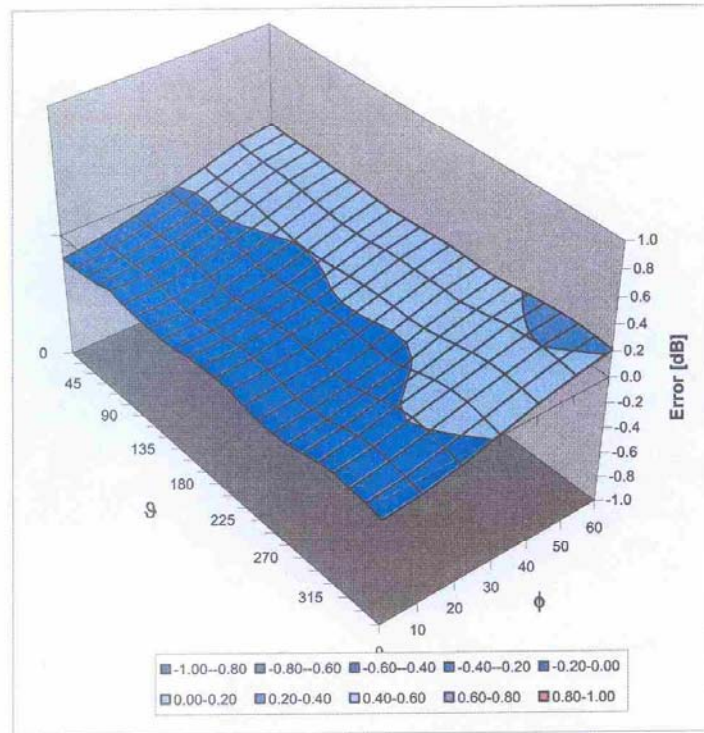

Uncertainty of Spherical Isotropy Assessment: $\pm 2.6\%$ (k=2)

ANNEX F DIPOLE CALIBRATION CERTIFICATE

835 MHz Dipole Calibration Certificate

**Calibration Laboratory of
Schmid & Partner
Engineering AG**
Zeughausstrasse 43, 8004 Zurich, Switzerland



S Schweizerischer Kalibrierdienst
C Service suisse d'étalonnage
S Servizio svizzero di taratura
S Swiss Calibration Service

Accredited by the Swiss Accreditation Service (SAS)
The Swiss Accreditation Service is one of the signatories to the EA
Multilateral Agreement for the recognition of calibration certificates

Accreditation No.: **SCS 108**

Client **TMC China**

Certificate No: **D835V2-443_Oct09**

CALIBRATION CERTIFICATE																																															
Object	D835V2-SN: 443																																														
Calibration procedure(s)	QA CAL-05.v6 Calibration procedure for dipole validation kits																																														
Calibration date:	October 25, 2009																																														
Condition of the calibrated item	In Tolerance																																														
<p>This calibration certificate documents the traceability to national standards, which realize the physical units of measurements(SI). The measurements and the uncertainties with confidence probability are given on the following pages and are part of the certificate.</p> <p>All calibrations have been conducted at an environment temperature (22±3)^oC and humidity<70%</p> <p>Calibration Equipment used (M&TE critical for calibration)</p> <table border="1"> <thead> <tr> <th>Primary Standards</th> <th>ID#</th> <th>Cal Data (Calibrated by, Certification NO.)</th> <th>Scheduled Calibration</th> </tr> </thead> <tbody> <tr> <td>Power meter EPM-442A</td> <td>GB37480704</td> <td>01-Oct-09 (METAS, NO. 217-00608)</td> <td>Oct-10</td> </tr> <tr> <td>Power sensor 8481A</td> <td>US37292783</td> <td>01-Oct-09 (METAS, NO. 217-00608)</td> <td>Oct-10</td> </tr> <tr> <td>Reference 20 dB Attenuator</td> <td>SN:5086 (20g)</td> <td>08-Aug-09 (METAS, NO. 217-00591)</td> <td>Aug-10</td> </tr> <tr> <td>Reference 10 dB Attenuator</td> <td>SN:5047_2 (10r)</td> <td>08-Aug-09 (METAS, NO. 217-00591)</td> <td>Aug-10</td> </tr> <tr> <td>DAE4</td> <td>SN:601</td> <td>28-Jan-09 (SPEAG, NO.DAE4-601_Jan09)</td> <td>Jan-10</td> </tr> <tr> <td>Reference Probe ET3DV6 (HF)</td> <td>SN: 1507</td> <td>17-Oct-09 (SPEAG, NO. ET3-1507_Oct09)</td> <td>Oct-10</td> </tr> </tbody> </table> <table border="1"> <thead> <tr> <th>Secondary Standards</th> <th>ID#</th> <th>Check Data (in house)</th> <th>Scheduled Calibration</th> </tr> </thead> <tbody> <tr> <td>Power sensor HP 8481A</td> <td>MY41092317</td> <td>18-Oct-02(SPEAG, in house check Oct-09)</td> <td>In house check: Oct-10</td> </tr> <tr> <td>RF generator Agilent E4421B</td> <td>MY41000676</td> <td>11-May-05(SPEAG, in house check Nov-07)</td> <td>In house check: Nov -09</td> </tr> <tr> <td>Network Analyzer HP 8753E</td> <td>US37390585S4206</td> <td>18-Oct-01(SPEAG, in house check Oct-09)</td> <td>In house check: Oct -10</td> </tr> </tbody> </table>				Primary Standards	ID#	Cal Data (Calibrated by, Certification NO.)	Scheduled Calibration	Power meter EPM-442A	GB37480704	01-Oct-09 (METAS, NO. 217-00608)	Oct-10	Power sensor 8481A	US37292783	01-Oct-09 (METAS, NO. 217-00608)	Oct-10	Reference 20 dB Attenuator	SN:5086 (20g)	08-Aug-09 (METAS, NO. 217-00591)	Aug-10	Reference 10 dB Attenuator	SN:5047_2 (10r)	08-Aug-09 (METAS, NO. 217-00591)	Aug-10	DAE4	SN:601	28-Jan-09 (SPEAG, NO.DAE4-601_Jan09)	Jan-10	Reference Probe ET3DV6 (HF)	SN: 1507	17-Oct-09 (SPEAG, NO. ET3-1507_Oct09)	Oct-10	Secondary Standards	ID#	Check Data (in house)	Scheduled Calibration	Power sensor HP 8481A	MY41092317	18-Oct-02(SPEAG, in house check Oct-09)	In house check: Oct-10	RF generator Agilent E4421B	MY41000676	11-May-05(SPEAG, in house check Nov-07)	In house check: Nov -09	Network Analyzer HP 8753E	US37390585S4206	18-Oct-01(SPEAG, in house check Oct-09)	In house check: Oct -10
Primary Standards	ID#	Cal Data (Calibrated by, Certification NO.)	Scheduled Calibration																																												
Power meter EPM-442A	GB37480704	01-Oct-09 (METAS, NO. 217-00608)	Oct-10																																												
Power sensor 8481A	US37292783	01-Oct-09 (METAS, NO. 217-00608)	Oct-10																																												
Reference 20 dB Attenuator	SN:5086 (20g)	08-Aug-09 (METAS, NO. 217-00591)	Aug-10																																												
Reference 10 dB Attenuator	SN:5047_2 (10r)	08-Aug-09 (METAS, NO. 217-00591)	Aug-10																																												
DAE4	SN:601	28-Jan-09 (SPEAG, NO.DAE4-601_Jan09)	Jan-10																																												
Reference Probe ET3DV6 (HF)	SN: 1507	17-Oct-09 (SPEAG, NO. ET3-1507_Oct09)	Oct-10																																												
Secondary Standards	ID#	Check Data (in house)	Scheduled Calibration																																												
Power sensor HP 8481A	MY41092317	18-Oct-02(SPEAG, in house check Oct-09)	In house check: Oct-10																																												
RF generator Agilent E4421B	MY41000676	11-May-05(SPEAG, in house check Nov-07)	In house check: Nov -09																																												
Network Analyzer HP 8753E	US37390585S4206	18-Oct-01(SPEAG, in house check Oct-09)	In house check: Oct -10																																												
Calibrated by:	Name Marcel Fehr	Function Laboratory Technician	Signature 																																												
Approved by:	Name Katja Pokovic	Function Technical Director	Signature 																																												
Issued: October 25, 2009																																															
This calibration certificate shall not be reported except in full without written approval of the laboratory.																																															

**Calibration Laboratory of
Schmid & Partner
Engineering AG**
Zeughausstrasse 43, 8004 Zurich, Switzerland



S Schweizerischer Kalibrierdienst
C Service suisse d'étalonnage
S Servizio svizzero di taratura
S Swiss Calibration Service

Accredited by the Swiss Federal Office of Metrology and Accreditation
The Swiss Accreditation Service is one of the signatories to the EA
Multilateral Agreement for the recognition of calibration certificates

Accreditation No.: **SCS 108**

Glossary:

TSL tissue simulating liquid
ConvF sensitivity in TSL / NORM x,y,z
N/A not applicable or not measured

Calibration is Performed According to the Following Standards:

- a) IEEE Std 1528-2003, "IEEE Recommended Practice for Determining the Peak Spatial-Averaged Specific Absorption Rate (SAR) in the Human Head from Wireless Communications Devices: Measurement Techniques", December 2003
- b) CENELEC EN 50361, "Basic standard for the measurement of Specific Absorption Rate related to human exposure to electromagnetic fields from mobile phones (300 MHz - 3 GHz), July 2001
- c) Federal Communications Commission Office of Engineering & Technology (FCC OET), "Evaluating Compliance with FCC Guidelines for Human Exposure to Radiofrequency Electromagnetic Fields; Additional Information for Evaluating Compliance of Mobile and Portable Devices with FCC Limits for Human Exposure to Radiofrequency Emissions", Supplement C (Edition 01-01) to Bulletin 65

Additional Documentation:

- d) DASY4 System Handbook

Methods Applied and Interpretation of Parameters:

- *Measurement Conditions:* Further details are available from the Validation Report at the end of the certificate. All figures stated in the certificate are valid at the frequency indicated.
- *Antenna Parameters with TSL:* The dipole is mounted with the spacer to position its feed point exactly below the center marking of the flat phantom section, with the arms oriented parallel to the body axis.
- *Feed Point Impedance and Return Loss:* These parameters are measured with the dipole positioned under the liquid filled phantom. The impedance stated is transformed from the measurement at the SMA connector to the feed point. The Return Loss ensures low reflected power. No uncertainty required.
- *Electrical Delay:* One-way delay between the SMA connector and the antenna feed point. No uncertainty required.
- *SAR measured:* SAR measured at the stated antenna input power.
- *SAR normalized:* SAR as measured, normalized to an input power of 1 W at the antenna connector.
- *SAR for nominal TSL parameters:* The measured TSL parameters are used to calculate the nominal SAR result.

Measurement Conditions

DASY system configuration, as far as not given on page 1.

DASY Version	DASY4	V4.7
Extrapolation	Advanced Extrapolation	
Phantom	Modular Flat Phantom V4.9	
Distance Dipole Center - TSL	15 mm	with Spacer
Zoom Scan Resolution	dx, dy, dz = 5 mm	
Frequency	835 MHz \pm 1 MHz	

Head TSL parameters

The following parameters and calculations were applied.

	Temperature	Permittivity	Conductivity
Nominal Head TSL parameters	22.0 °C	41.5	0.90 mho/m
Measured Head TSL parameters	(22.0 \pm 0.2) °C	41.4 \pm 6 %	0.91 mho/m \pm 6 %
Head TSL temperature during test	(21.5 \pm 0.2) °C	----	----

SAR result with Head TSL

SAR averaged over 1 cm^3 (1 g) of Head TSL	Condition	
SAR measured	250 mW input power	2.43 mW / g
SAR normalized	normalized to 1W	9.72 mW / g
SAR for nominal Head TSL parameters ¹	normalized to 1W	9.65 mW /g \pm 17.0 % (k=2)

SAR averaged over 10 cm^3 (10 g) of Head TSL	Condition	
SAR measured	250 mW input power	1.57 mW / g
SAR normalized	normalized to 1W	6.28 mW / g
SAR for nominal Head TSL parameters ¹	normalized to 1W	6.25 mW /g \pm 16.5 % (k=2)

¹ Correction to nominal TSL parameters according to d), chapter "SAR Sensitivities"

Body TSL parameters

The following parameters and calculations were applied.

	Temperature	Permittivity	Conductivity
Nominal Body TSL parameters	22.0 °C	55.2	0.97 mho/m
Measured Body TSL parameters	(22.0 ± 0.2) °C	54.9 ± 6 %	0.98 mho/m ± 6 %
Body TSL temperature during test	(21.5 ± 0.2) °C	----	----

SAR result with Body TSL

SAR averaged over 1 cm^3 (1 g) of Body TSL	Condition	
SAR measured	250 mW input power	2.46 mW / g
SAR normalized	normalized to 1W	9.84 mW / g
SAR for nominal Body TSL parameters ²	normalized to 1W	9.75 mW /g ± 17.0 % (k=2)

SAR averaged over 10 cm^3 (10 g) of Body TSL	Condition	
SAR measured	250 mW input power	1.60 mW / g
SAR normalized	normalized to 1W	6.40 mW / g
SAR for nominal Body TSL parameters ²	normalized to 1W	6.36 mW /g ± 16.5 % (k=2)

² Correction to nominal TSL parameters according to d), chapter "SAR Sensitivities"

Appendix

Antenna Parameters with Head TSL

Impedance, transformed to feed point	52.1Ω -3.5 jΩ
Return Loss	- 25.5dB

Antenna Parameters with Body TSL

Impedance, transformed to feed point	49.6Ω - 5.3 jΩ
Return Loss	-25.8dB

General Antenna Parameters and Design

Electrical Delay (one direction)	2.572 ns
----------------------------------	----------

After long term use with 100W radiated power, only a slight warming of the dipole near the feedpoint can be measured.

The dipole is made of standard semirigid coaxial cable. The center conductor of the feeding line is directly connected to the second arm of the dipole. The antenna is therefore short-circuited for DC-signals. No excessive force must be applied to the dipole arms, because they might bend or the soldered connections near the feedpoint may be damaged.

Additional EUT Data

Manufactured by	SPEAG
Manufactured on	September 3, 2001

DASY4 Validation Report for Head TSL

Date/Time: 25.10.2009 10:26:37

Test laboratory: SPEAG, Zurich, Switzerland

DUT: Dipole 835 MHz; Type: D835V2; serial: D835V2-SN: 443

Communication System: CW; Frequency: 835 MHz; Duty Cycle: 1:1

Medium: Head 835 MHz;

Medium parameters used: $f=835$ MHz; $\sigma=0.91$ mho/m; $\epsilon_r=41.4$; $\rho=1000$ kg/m³

Phantom section: Flat Section

Measurement Standard: DASY4 (High Precision Assessment)

DASY4 Configuration:

- Probe: ET3DV6-SN1507(HF); ConvF(6.01,6.01,6.01); Calibrated: 17.10.2009
- Sensor-Surface: 4mm (Mechanical Surface Detection)
- Electronics: DAE4 Sn601; Calibrated: 28.1_2009
- Phantom: Flat Phantom 4.9L; Type: QD000P49AA;
- Measurement SW: DASY, V4.7 Build 53; Post processing SW: SEMCAD, V1.8 Build 172

Pin = 250 mW; d = 15 mm/Zoom Scan (7x7x7)/Cube 0: Measurement grid: dx=5mm, dy=5mm, dz=5mm

Reference Value = 57.5 V/m; Power Drift = 0.048 dB

Peak SAR (extrapolated) = 3.76 W/kg

SAR(1 g) = 2.43 mW/g; SAR(10 g) = 1.57 mW/g

Maximum value of SAR (measured) = 2.75 mW/g

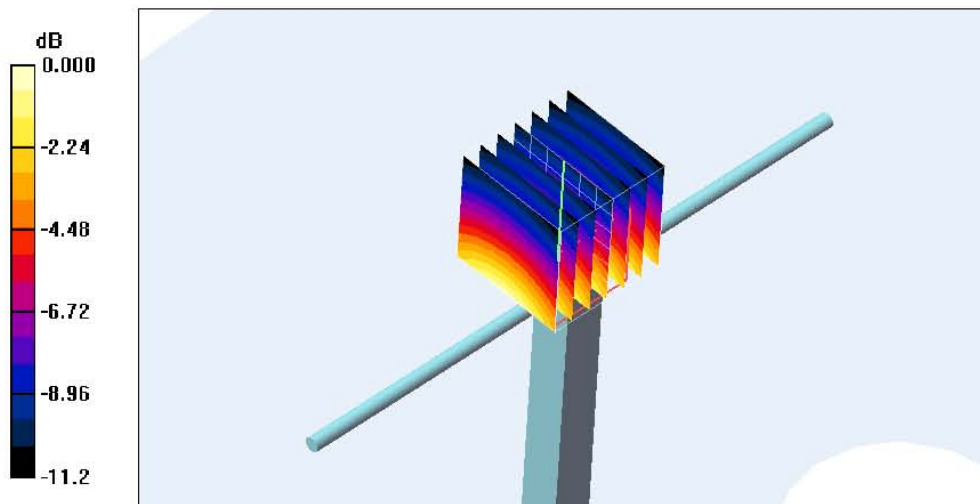

0 dB = 2.75mW/g

Impedance measurement Plot for Head TSL

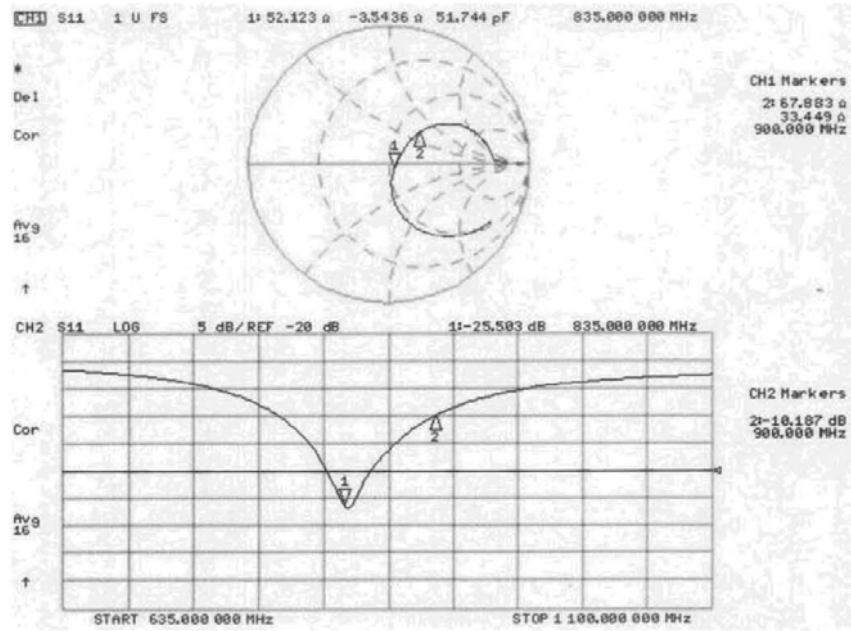

DASY4 Validation Report for Body TSL

Date/Time: 25.10.2009 14:47:03

Test laboratory: SPEAG, Zurich, Switzerland

DUT: Dipole 835 MHz; Type: D835V2; serial: D835V2-SN: 443

Communication System: CW; Frequency: 835 MHz; Duty Cycle: 1:1

Medium: Body 835 MHz;

Medium parameters used: $f=835$ MHz; $\sigma=0.98$ mho/m; $\epsilon_r=54.9$; $\rho= 1000$ kg/m³

Phantom section: Flat Section

Measurement Standard: DASY4 (High Precision Assessment)

DASY4 Configuration:

- Probe: ET3DV6-SN1507(HF); ConvF(5.75,5.75,5.75); Calibrated: 17.10.2009
- Sensor-Surface: 4mm (Mechanical Surface Detection)
- Electronics: DAE4 Sn601; Calibrated: 28.1_2009
- Phantom: Flat Phantom 4.9L; Type: QD000P49AA;
- Measurement SW: DASY, V4.7 Build 53; Post processing SW: SEMCAD, V1.8 Build 172

Pin = 250 mW; d = 15 mm/Zoom Scan (7x7x7)/Cube 0: Measurement grid: dx=5mm, dy=5mm, dz=5mm

Reference Value = 57.9 V/m; Power Drift = 0.061 dB

Peak SAR (extrapolated) = 3.80 W/kg

SAR(1 g) = 2.46 mW/g; SAR(10 g) = 1.60 mW/g

Maximum value of SAR (measured) = 2.78 mW/g

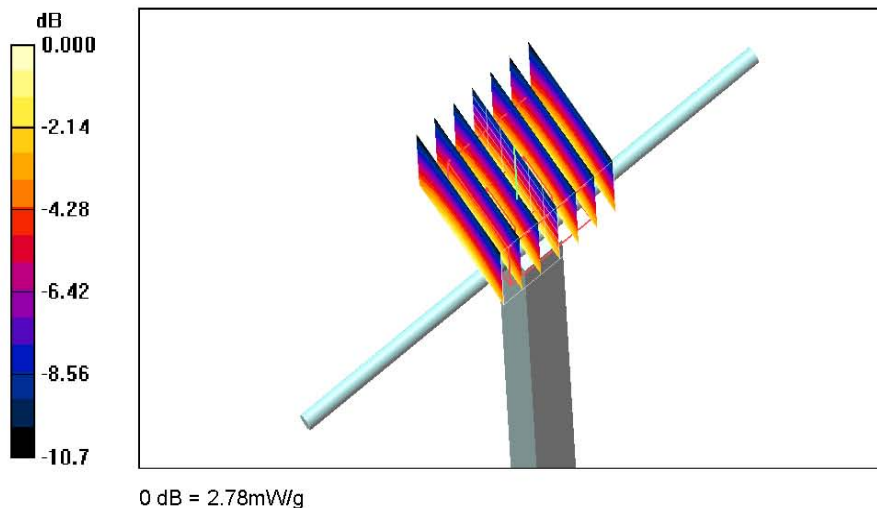

Impedance measurement Plot for Body TSL

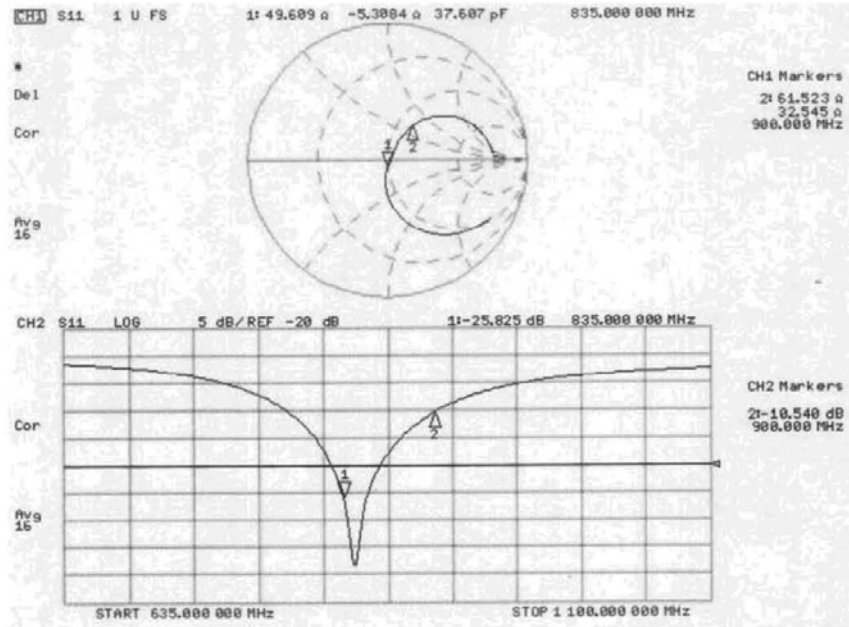

1900 MHz Dipole Calibration Certificate

**Calibration Laboratory of
Schmid & Partner
Engineering AG**
Zeughausstrasse 43, 8004 Zurich, Switzerland



S Schweizerischer Kalibrierdienst
S Service suisse d'étalonnage
C Servizio svizzero di taratura
S Swiss Calibration Service

Accredited by the Swiss Accreditation Service (SAS)
The Swiss Accreditation Service is one of the signatories to the EA
Multilateral Agreement for the recognition of calibration certificates

Accreditation No.: **SCS 108**

Client **TMC China**

Certificate No: **D1900V2-541_Oct09**

CALIBRATION CERTIFICATE																																															
Object	D1900V2-SN: 541																																														
Calibration procedure(s)	QA CAL-05.v6 Calibration procedure for dipole validation kits																																														
Calibration date:	October 26, 2009																																														
Condition of the calibrated item	In Tolerance																																														
<p>This calibration certificate documents the traceability to national standards, which realize the physical units of measurements(SI). The measurements and the uncertainties with confidence probability are given on the following pages and are part of the certificate.</p> <p>All calibrations have been conducted at an environment temperature (22±3)°C and humidity<70%</p> <p>Calibration Equipment used (M&TE critical for calibration)</p> <table border="1"> <thead> <tr> <th>Primary Standards</th> <th>ID#</th> <th>Cal Data (Calibrated by, Certification NO.)</th> <th>Scheduled Calibration</th> </tr> </thead> <tbody> <tr> <td>Power meter EPM-442A</td> <td>GB37480704</td> <td>01-Oct-09 (METAS, NO. 217-00608)</td> <td>Oct-10</td> </tr> <tr> <td>Power sensor 8481A</td> <td>US37292783</td> <td>01-Oct-09 (METAS, NO. 217-00608)</td> <td>Oct-10</td> </tr> <tr> <td>Reference 20 dB Attenuator</td> <td>SN:5086 (20g)</td> <td>08-Aug-09 (METAS, NO. 217-00591)</td> <td>Aug-10</td> </tr> <tr> <td>Reference 10 dB Attenuator</td> <td>SN:5047_2 (10r)</td> <td>08-Aug-09 (METAS, NO. 217-00591)</td> <td>Aug-10</td> </tr> <tr> <td>DAE4</td> <td>SN:601</td> <td>28-Jan-09 (SPEAG, NO.DAE4-601_Jan09)</td> <td>Jan-10</td> </tr> <tr> <td>Reference Probe ET3DV6 (HF)</td> <td>SN: 1507</td> <td>17-Oct-09 (SPEAG, NO. ET3-1507_Oct09)</td> <td>Oct-10</td> </tr> <tr> <th>Secondary Standards</th> <th>ID#</th> <th>Check Data (in house)</th> <th>Scheduled Calibration</th> </tr> <tr> <td>Power sensor HP 8481A</td> <td>MY41092317</td> <td>18-Oct-02(SPEAG, in house check Oct-09)</td> <td>In house check: Oct-10</td> </tr> <tr> <td>RF generator Aglient E4421B</td> <td>MY41000676</td> <td>11-May-05(SPEAG, in house check Nov-07)</td> <td>In house check: Nov -09</td> </tr> <tr> <td>Network Analyzer HP 8753E</td> <td>US37390585S4206</td> <td>18-Oct-01(SPEAG, in house check Oct-09)</td> <td>In house check: Oct -10</td> </tr> </tbody> </table>				Primary Standards	ID#	Cal Data (Calibrated by, Certification NO.)	Scheduled Calibration	Power meter EPM-442A	GB37480704	01-Oct-09 (METAS, NO. 217-00608)	Oct-10	Power sensor 8481A	US37292783	01-Oct-09 (METAS, NO. 217-00608)	Oct-10	Reference 20 dB Attenuator	SN:5086 (20g)	08-Aug-09 (METAS, NO. 217-00591)	Aug-10	Reference 10 dB Attenuator	SN:5047_2 (10r)	08-Aug-09 (METAS, NO. 217-00591)	Aug-10	DAE4	SN:601	28-Jan-09 (SPEAG, NO.DAE4-601_Jan09)	Jan-10	Reference Probe ET3DV6 (HF)	SN: 1507	17-Oct-09 (SPEAG, NO. ET3-1507_Oct09)	Oct-10	Secondary Standards	ID#	Check Data (in house)	Scheduled Calibration	Power sensor HP 8481A	MY41092317	18-Oct-02(SPEAG, in house check Oct-09)	In house check: Oct-10	RF generator Aglient E4421B	MY41000676	11-May-05(SPEAG, in house check Nov-07)	In house check: Nov -09	Network Analyzer HP 8753E	US37390585S4206	18-Oct-01(SPEAG, in house check Oct-09)	In house check: Oct -10
Primary Standards	ID#	Cal Data (Calibrated by, Certification NO.)	Scheduled Calibration																																												
Power meter EPM-442A	GB37480704	01-Oct-09 (METAS, NO. 217-00608)	Oct-10																																												
Power sensor 8481A	US37292783	01-Oct-09 (METAS, NO. 217-00608)	Oct-10																																												
Reference 20 dB Attenuator	SN:5086 (20g)	08-Aug-09 (METAS, NO. 217-00591)	Aug-10																																												
Reference 10 dB Attenuator	SN:5047_2 (10r)	08-Aug-09 (METAS, NO. 217-00591)	Aug-10																																												
DAE4	SN:601	28-Jan-09 (SPEAG, NO.DAE4-601_Jan09)	Jan-10																																												
Reference Probe ET3DV6 (HF)	SN: 1507	17-Oct-09 (SPEAG, NO. ET3-1507_Oct09)	Oct-10																																												
Secondary Standards	ID#	Check Data (in house)	Scheduled Calibration																																												
Power sensor HP 8481A	MY41092317	18-Oct-02(SPEAG, in house check Oct-09)	In house check: Oct-10																																												
RF generator Aglient E4421B	MY41000676	11-May-05(SPEAG, in house check Nov-07)	In house check: Nov -09																																												
Network Analyzer HP 8753E	US37390585S4206	18-Oct-01(SPEAG, in house check Oct-09)	In house check: Oct -10																																												
Calibrated by:	Name Marcel Fehr	Function Laboratory Technician	Signature 																																												
Approved by:	Name Katja Pokovic	Function Technical Director	Signature 																																												
Issued: October 26, 2009																																															
This calibration certificate shall not be reported except in full without written approval of the laboratory.																																															

**Calibration Laboratory of
Schmid & Partner
Engineering AG**
Zeughausstrasse 43, 8004 Zurich, Switzerland



S Schweizerischer Kalibrierdienst
C Service suisse d'étalonnage
S Servizio svizzero di taratura
S Swiss Calibration Service

Accredited by the Swiss Federal Office of Metrology and Accreditation
The Swiss Accreditation Service is one of the signatories to the EA
Multilateral Agreement for the recognition of calibration certificates

Accreditation No.: **SCS 108**

Glossary:

TSL tissue simulating liquid
ConvF sensitivity in TSL / NORM x,y,z
N/A not applicable or not measured

Calibration is Performed According to the Following Standards:

- a) IEEE Std 1528-2003, "IEEE Recommended Practice for Determining the Peak Spatial-Averaged Specific Absorption Rate (SAR) in the Human Head from Wireless Communications Devices: Measurement Techniques", December 2003
- b) CENELEC EN 50361, "Basic standard for the measurement of Specific Absorption Rate related to human exposure to electromagnetic fields from mobile phones (300 MHz - 3 GHz), July 2001
- c) Federal Communications Commission Office of Engineering & Technology (FCC OET), "Evaluating Compliance with FCC Guidelines for Human Exposure to Radiofrequency Electromagnetic Fields; Additional Information for Evaluating Compliance of Mobile and Portable Devices with FCC Limits for Human Exposure to Radiofrequency Emissions", Supplement C (Edition 01-01) to Bulletin 65

Additional Documentation:

- d) DASY4 System Handbook

Methods Applied and Interpretation of Parameters:

- *Measurement Conditions:* Further details are available from the Validation Report at the end of the certificate. All figures stated in the certificate are valid at the frequency indicated.
- *Antenna Parameters with TSL:* The dipole is mounted with the spacer to position its feed point exactly below the center marking of the flat phantom section, with the arms oriented parallel to the body axis.
- *Feed Point Impedance and Return Loss:* These parameters are measured with the dipole positioned under the liquid filled phantom. The impedance stated is transformed from the measurement at the SMA connector to the feed point. The Return Loss ensures low reflected power. No uncertainty required.
- *Electrical Delay:* One-way delay between the SMA connector and the antenna feed point. No uncertainty required.
- *SAR measured:* SAR measured at the stated antenna input power.
- *SAR normalized:* SAR as measured, normalized to an input power of 1 W at the antenna connector.
- *SAR for nominal TSL parameters:* The measured TSL parameters are used to calculate the nominal SAR result.

Measurement Conditions

DASY system configuration, as far as not given on page 1.

DASY Version	DASY4	V4.7
Extrapolation	Advanced Extrapolation	
Phantom	Modular Flat Phantom V4.9	
Distance Dipole Center - TSL	10 mm	with Spacer
Zoom Scan Resolution	dx, dy, dz = 5 mm	
Frequency	1900 MHz \pm 1 MHz	

Head TSL parameters

The following parameters and calculations were applied.

	Temperature	Permittivity	Conductivity
Nominal Head TSL parameters	22.0 °C	40.0	1.40 mho/m
Measured Head TSL parameters	(22.0 \pm 0.2) °C	39.7 \pm 6 %	1.41 mho/m \pm 6 %
Head TSL temperature during test	(21.5 \pm 0.2) °C	----	----

SAR result with Head TSL

SAR averaged over 1 cm^3 (1 g) of Head TSL	Condition	
SAR measured	250 mW input power	9.97 mW / g
SAR normalized	normalized to 1W	39.9 mW / g
SAR for nominal Head TSL parameters ¹	normalized to 1W	39.6 mW /g \pm 17.0 % (k=2)

SAR averaged over 10 cm^3 (10 g) of Head TSL	Condition	
SAR measured	250 mW input power	5.12 mW / g
SAR normalized	normalized to 1W	20.5 mW / g
SAR for nominal Head TSL parameters ¹	normalized to 1W	20.4 mW /g \pm 16.5 % (k=2)

¹ Correction to nominal TSL parameters according to d), chapter "SAR Sensitivities"

Body TSL parameters

The following parameters and calculations were applied.

	Temperature	Permittivity	Conductivity
Nominal Body TSL parameters	22.0 °C	53.3	1.52 mho/m
Measured Body TSL parameters	(22.0 ± 0.2) °C	52.3 ± 6 %	1.51 mho/m ± 6 %
Body TSL temperature during test	(21.5 ± 0.2) °C	----	----

SAR result with Body TSL

SAR averaged over 1 cm^3 (1 g) of Body TSL	Condition	
SAR measured	250 mW input power	10.4 mW / g
SAR normalized	normalized to 1W	41.6 mW / g
SAR for nominal Body TSL parameters ²	normalized to 1W	41.3 mW /g ± 17.0 % (k=2)

SAR averaged over 10 cm^3 (10 g) of Body TSL	Condition	
SAR measured	250 mW input power	5.29 mW / g
SAR normalized	normalized to 1W	21.2 mW / g
SAR for nominal Body TSL parameters ²	normalized to 1W	21.1 mW /g ± 16.5 % (k=2)

² Correction to nominal TSL parameters according to d), chapter "SAR Sensitivities"

Appendix

Antenna Parameters with Head TSL

Impedance, transformed to feed point	$54.4\Omega + 5.8 j\Omega$
Return Loss	- 23.0dB

Antenna Parameters with Body TSL

Impedance, transformed to feed point	$47.6\Omega + 7.0 j\Omega$
Return Loss	- 22.4dB

General Antenna Parameters and Design

Electrical Delay (one direction)	1.883 ns
----------------------------------	----------

After long term use with 100W radiated power, only a slight warming of the dipole near the feedpoint can be measured.

The dipole is made of standard semirigid coaxial cable. The center conductor of the feeding line is directly connected to the second arm of the dipole. The antenna is therefore short-circuited for DC-signals. No excessive force must be applied to the dipole arms, because they might bend or the soldered connections near the feedpoint may be damaged.

Additional EUT Data

Manufactured by	SPEAG
Manufactured on	October 4, 2001

DASY4 Validation Report for Head TSL

Date/Time: 26.10.2009 9:20:41

Test laboratory: SPEAG, Zurich, Switzerland

DUT: Dipole 1900 MHz; Type: D1900V2; serial: D1900V2-SN: 541

Communication System: CW; Frequency: 1900 MHz; Duty Cycle: 1:1

Medium: Head 1900 MHz;

Medium parameters used: $f=1900$ MHz; $\sigma=1.41$ mho/m; $\epsilon_r=39.7$; $\rho=1000$ kg/m³

Phantom section: Flat Section

Measurement Standard: DASY4 (High Precision Assessment)

DASY4 Configuration:

- Probe: ET3DV6-SN1507(HF); ConvF(5.03,5.03,5.03); Calibrated: 17.10.2009
- Sensor-Surface: 4mm (Mechanical Surface Detection)
- Electronics: DAE4 Sn601; Calibrated: 28.1_2009
- Phantom: Flat Phantom 4.9L; Type: QD000P49AA;
- Measurement SW: DASY, V4.7 Build 53; Post processing SW: SEMCAD, V1.8 Build 172

Pin = 250 mW; d = 10 mm/Zoom Scan (7x7x7)/Cube 0: Measurement grid: dx=5mm, dy=5mm, dz=5mm

Reference Value = 85.9 V/m; Power Drift = 0.053 dB

Peak SAR (extrapolated) = 18.9 W/kg

SAR(1 g) = 9.97 mW/g; SAR(10 g) = 5.12 mW/g

Maximum value of SAR (measured) = 11.5 mW/g

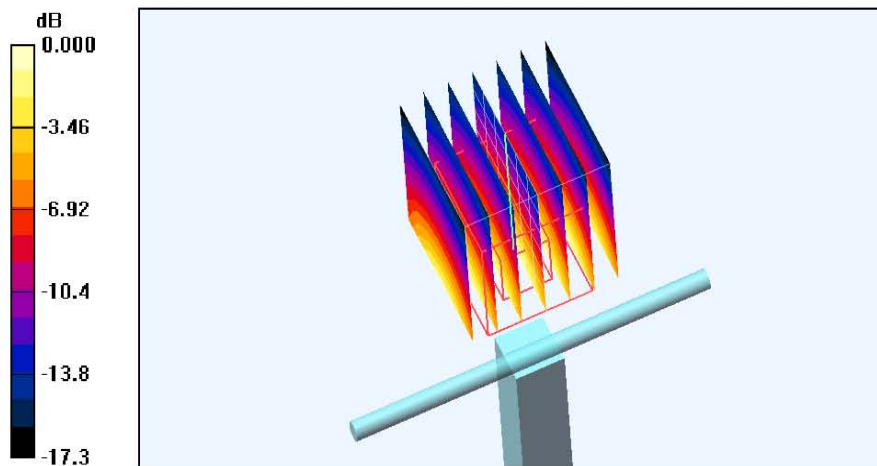

0 dB = 11.5mW/g

Impedance measurement Plot for Head TSL

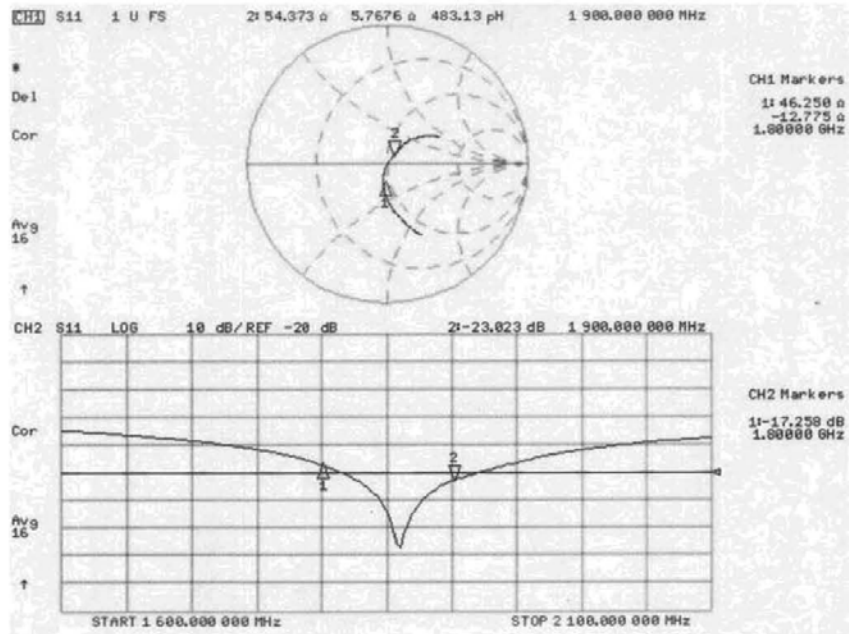

DASY4 Validation Report for Body TSL

Date/Time: 26.10.2009 13:18:39

Test laboratory: SPEAG, Zurich, Switzerland

DUT: Dipole 1900 MHz; Type: D1900V2; serial: D1900V2-SN: 541

Communication System: CW; Frequency: 1900 MHz; Duty Cycle: 1:1

Medium: Body 1900 MHz;

Medium parameters used: $f=1900$ MHz; $\sigma=1.51$ mho/m; $\epsilon_r=52.3$; $\rho=1000$ kg/m³

Phantom section: Flat Section

Measurement Standard: DASY4 (High Precision Assessment)

DASY4 Configuration:

- Probe: ET3DV6-SN1507(HF); ConvF(4.61,4.61,4.61); Calibrated: 17.10.2009
- Sensor-Surface: 4mm (Mechanical Surface Detection)
- Electronics: DAE4 Sn601; Calibrated: 28.1_2009
- Phantom: Flat Phantom 4.9L; Type: QD000P49AA;
- Measurement SW: DASY, V4.7 Build 53; Post processing SW: SEMCAD, V1.8 Build 172

Pin = 250 mW; d = 15 mm/Zoom Scan (7x7x7)/Cube 0: Measurement grid: dx=5mm, dy=5mm, dz=5mm

Reference Value = 80.6 V/m; Power Drift = 0.047 dB

Peak SAR (extrapolated) = 19.2 W/kg

SAR(1 g) = 10.4 mW/g; SAR(10 g) = 5.29 mW/g

Maximum value of SAR (measured) = 12.1 mW/g

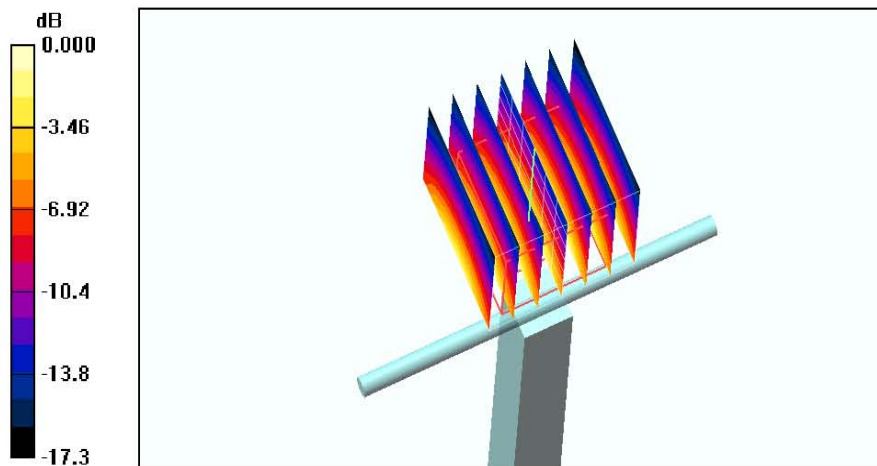

0 dB = 12.1mW/g

Impedance measurement Plot for Body TSL

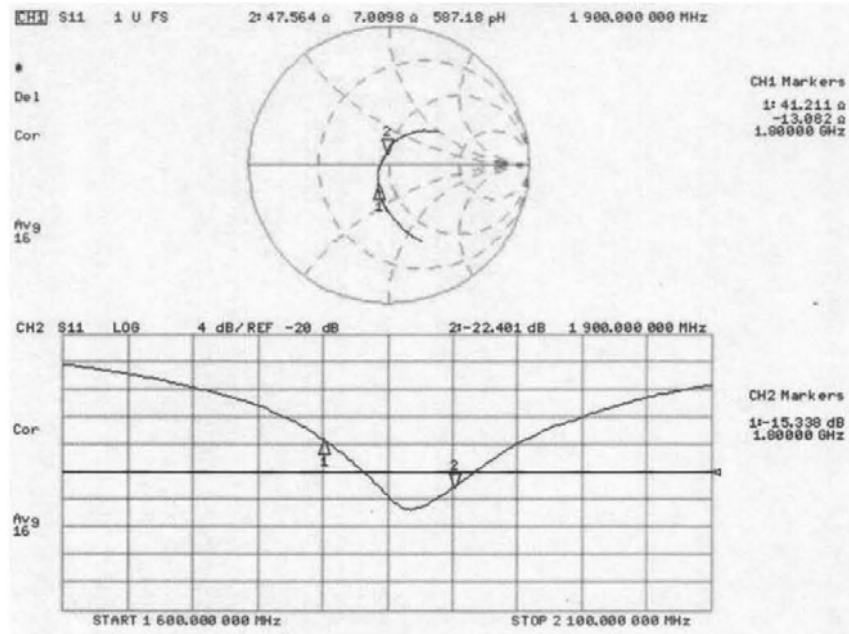

2450 MHz Dipole Calibration Certificate

**Calibration Laboratory of
Schmid & Partner
Engineering AG**
Zeughausstrasse 43, 8004 Zurich, Switzerland



S Schweizerischer Kalibrierdienst
C Service suisse d'étalonnage
S Servizio svizzero di taratura
S Swiss Calibration Service

Accredited by the Swiss Accreditation Service (SAS)
The Swiss Accreditation Service is one of the signatories to the EA
Multilateral Agreement for the recognition of calibration certificates

Accreditation No.: **SCS 108**

Client **ATL (Auden)**

Certificate No: **D2450V2-712_Feb10**

CALIBRATION CERTIFICATE																																															
Object	D2450V2 - SN: 712																																														
Calibration procedure(s)	QA CAL-05.v7 Calibration procedure for dipole validation kits																																														
Calibration date:	February 19, 2010																																														
<p>This calibration certificate documents the traceability to national standards, which realize the physical units of measurements (SI). The measurements and the uncertainties with confidence probability are given on the following pages and are part of the certificate.</p> <p>All calibrations have been conducted in the closed laboratory facility: environment temperature (22 ± 3)°C and humidity < 70%.</p> <p>Calibration Equipment used (M&TE critical for calibration)</p> <table border="1"> <thead> <tr> <th>Primary Standards</th> <th>ID #</th> <th>Cal Date (Certificate No.)</th> <th>Scheduled Calibration</th> </tr> </thead> <tbody> <tr> <td>Power meter EPM-442A</td> <td>GB37480704</td> <td>06-Oct-09 (No. 217-01086)</td> <td>Oct-10</td> </tr> <tr> <td>Power sensor HP 8481A</td> <td>US37292783</td> <td>06-Oct-09 (No. 217-01086)</td> <td>Oct-10</td> </tr> <tr> <td>Reference 20 dB Attenuator</td> <td>SN: 5086 (20g)</td> <td>31-Mar-09 (No. 217-01025)</td> <td>Mar-10</td> </tr> <tr> <td>Type-N mismatch combination</td> <td>SN: 5047.2 / 06327</td> <td>31-Mar-09 (No. 217-01029)</td> <td>Mar-10</td> </tr> <tr> <td>Reference Probe ES3DV3</td> <td>SN: 3205</td> <td>26-Jun-09 (No. ES3-3205_Jun09)</td> <td>Jun-10</td> </tr> <tr> <td>DAE4</td> <td>SN: 801</td> <td>07-Mar-09 (No. DAE4-601_Mar09)</td> <td>Mar-10</td> </tr> </tbody> </table> <table border="1"> <thead> <tr> <th>Secondary Standards</th> <th>ID #</th> <th>Check Date (in house)</th> <th>Scheduled Check</th> </tr> </thead> <tbody> <tr> <td>Power sensor HP 8481A</td> <td>MY41092317</td> <td>18-Oct-02 (in house check Oct-09)</td> <td>In house check: Oct-11</td> </tr> <tr> <td>RF generator R&S SMT-06</td> <td>100005</td> <td>4-Aug-99 (in house check Oct-09)</td> <td>In house check: Oct-11</td> </tr> <tr> <td>Network Analyzer HP 8753E</td> <td>US37390585 S4206</td> <td>18-Oct-01 (in house check Oct-09)</td> <td>In house check: Oct-10</td> </tr> </tbody> </table>				Primary Standards	ID #	Cal Date (Certificate No.)	Scheduled Calibration	Power meter EPM-442A	GB37480704	06-Oct-09 (No. 217-01086)	Oct-10	Power sensor HP 8481A	US37292783	06-Oct-09 (No. 217-01086)	Oct-10	Reference 20 dB Attenuator	SN: 5086 (20g)	31-Mar-09 (No. 217-01025)	Mar-10	Type-N mismatch combination	SN: 5047.2 / 06327	31-Mar-09 (No. 217-01029)	Mar-10	Reference Probe ES3DV3	SN: 3205	26-Jun-09 (No. ES3-3205_Jun09)	Jun-10	DAE4	SN: 801	07-Mar-09 (No. DAE4-601_Mar09)	Mar-10	Secondary Standards	ID #	Check Date (in house)	Scheduled Check	Power sensor HP 8481A	MY41092317	18-Oct-02 (in house check Oct-09)	In house check: Oct-11	RF generator R&S SMT-06	100005	4-Aug-99 (in house check Oct-09)	In house check: Oct-11	Network Analyzer HP 8753E	US37390585 S4206	18-Oct-01 (in house check Oct-09)	In house check: Oct-10
Primary Standards	ID #	Cal Date (Certificate No.)	Scheduled Calibration																																												
Power meter EPM-442A	GB37480704	06-Oct-09 (No. 217-01086)	Oct-10																																												
Power sensor HP 8481A	US37292783	06-Oct-09 (No. 217-01086)	Oct-10																																												
Reference 20 dB Attenuator	SN: 5086 (20g)	31-Mar-09 (No. 217-01025)	Mar-10																																												
Type-N mismatch combination	SN: 5047.2 / 06327	31-Mar-09 (No. 217-01029)	Mar-10																																												
Reference Probe ES3DV3	SN: 3205	26-Jun-09 (No. ES3-3205_Jun09)	Jun-10																																												
DAE4	SN: 801	07-Mar-09 (No. DAE4-601_Mar09)	Mar-10																																												
Secondary Standards	ID #	Check Date (in house)	Scheduled Check																																												
Power sensor HP 8481A	MY41092317	18-Oct-02 (in house check Oct-09)	In house check: Oct-11																																												
RF generator R&S SMT-06	100005	4-Aug-99 (in house check Oct-09)	In house check: Oct-11																																												
Network Analyzer HP 8753E	US37390585 S4206	18-Oct-01 (in house check Oct-09)	In house check: Oct-10																																												
Calibrated by:	Name Jeton Kastrati	Function Laboratory Technician	Signature 																																												
Approved by:	Name Katja Pokovic	Function Technical Manager	Signature 																																												
			Issued: February 19, 2010																																												
This calibration certificate shall not be reproduced except in full without written approval of the laboratory.																																															

Calibration Laboratory of
Schmid & Partner
Engineering AG
Zeughausstrasse 43, 8004 Zurich, Switzerland



S Schweizerischer Kalibrierdienst
S Service suisse d'étalonnage
C Servizio svizzero di taratura
S Swiss Calibration Service

Accredited by the Swiss Accreditation Service (SAS)
The Swiss Accreditation Service is one of the signatories to the EA
Multilateral Agreement for the recognition of calibration certificates

Accreditation No.: **SCS 108**

Glossary:

TSL tissue simulating liquid
ConvF sensitivity in TSL / NORM x,y,z
N/A not applicable or not measured

Calibration is Performed According to the Following Standards:

- a) IEEE Std 1528-2003, "IEEE Recommended Practice for Determining the Peak Spatial-Averaged Specific Absorption Rate (SAR) in the Human Head from Wireless Communications Devices: Measurement Techniques", December 2003
- b) IEC 62209-1, "Procedure to measure the Specific Absorption Rate (SAR) for hand-held devices used in close proximity to the ear (frequency range of 300 MHz to 3 GHz)", February 2005
- c) Federal Communications Commission Office of Engineering & Technology (FCC OET), "Evaluating Compliance with FCC Guidelines for Human Exposure to Radiofrequency Electromagnetic Fields; Additional Information for Evaluating Compliance of Mobile and Portable Devices with FCC Limits for Human Exposure to Radiofrequency Emissions", Supplement C (Edition 01-01) to Bulletin 65

Additional Documentation:

- d) DASy4/5 System Handbook

Methods Applied and Interpretation of Parameters:

- *Measurement Conditions:* Further details are available from the Validation Report at the end of the certificate. All figures stated in the certificate are valid at the frequency indicated.
- *Antenna Parameters with TSL:* The dipole is mounted with the spacer to position its feed point exactly below the center marking of the flat phantom section, with the arms oriented parallel to the body axis.
- *Feed Point Impedance and Return Loss:* These parameters are measured with the dipole positioned under the liquid filled phantom. The impedance stated is transformed from the measurement at the SMA connector to the feed point. The Return Loss ensures low reflected power. No uncertainty required.
- *Electrical Delay:* One-way delay between the SMA connector and the antenna feed point. No uncertainty required.
- *SAR measured:* SAR measured at the stated antenna input power.
- *SAR normalized:* SAR as measured, normalized to an input power of 1 W at the antenna connector.
- *SAR for nominal TSL parameters:* The measured TSL parameters are used to calculate the nominal SAR result.

Measurement Conditions

DASY system configuration, as far as not given on page 1.

DASY Version	DASY5	V5.2
Extrapolation	Advanced Extrapolation	
Phantom	Modular Flat Phantom V4.9	
Distance Dipole Center - TSL	10 mm	with Spacer
Zoom Scan Resolution	dx, dy, dz = 5 mm	
Frequency	2450 MHz \pm 1 MHz	

Head TSL parameters

The following parameters and calculations were applied.

	Temperature	Permittivity	Conductivity
Nominal Head TSL parameters	22.0 °C	39.2	1.80 mho/m
Measured Head TSL parameters	(22.0 \pm 0.2) °C	38.5 \pm 6 %	1.76 mho/m \pm 6 %
Head TSL temperature during test	(21.0 \pm 0.2) °C	----	----

SAR result with Head TSL

SAR averaged over 1 cm ³ (1 g) of Head TSL	Condition	
SAR measured	250 mW input power	13.3 mW / g
SAR normalized	normalized to 1W	53.2 mW / g
SAR for nominal Head TSL parameters	normalized to 1W	53.5 mW / g \pm 17.0 % (k=2)

SAR averaged over 10 cm ³ (10 g) of Head TSL	condition	
SAR measured	250 mW input power	6.24 mW / g
SAR normalized	normalized to 1W	25.0 mW / g
SAR for nominal Head TSL parameters	normalized to 1W	25.0 mW / g \pm 16.5 % (k=2)

Body TSL parameters

The following parameters and calculations were applied.

	Temperature	Permittivity	Conductivity
Nominal Body TSL parameters	22.0 °C	52.7	1.95 mho/m
Measured Body TSL parameters	(22.0 ± 0.2) °C	51.7 ± 6 %	2.00 mho/m ± 6 %
Body TSL temperature during test	(21.2 ± 0.2) °C	----	----

SAR result with Body TSL

SAR averaged over 1 cm ³ (1 g) of Body TSL	Condition	
SAR measured	250 mW input power	13.0 mW / g
SAR normalized	normalized to 1W	52.0 mW / g
SAR for nominal Body TSL parameters	normalized to 1W	51.1 mW / g ± 17.0 % (k=2)

SAR averaged over 10 cm ³ (10 g) of Body TSL	condition	
SAR measured	250 mW input power	5.97 mW / g
SAR normalized	normalized to 1W	23.9 mW / g
SAR for nominal Body TSL parameters	normalized to 1W	23.7 mW / g ± 16.5 % (k=2)

Appendix

Antenna Parameters with Head TSL

Impedance, transformed to feed point	54.2 Ω + 1.9 j Ω
Return Loss	- 27.1 dB

Antenna Parameters with Body TSL

Impedance, transformed to feed point	50.1 Ω + 5.2 j Ω
Return Loss	- 25.7 dB

General Antenna Parameters and Design

Electrical Delay (one direction)	1.144 ns
----------------------------------	----------

After long term use with 100W radiated power, only a slight warming of the dipole near the feedpoint can be measured.

The dipole is made of standard semirigid coaxial cable. The center conductor of the feeding line is directly connected to the second arm of the dipole. The antenna is therefore short-circuited for DC-signals.

No excessive force must be applied to the dipole arms, because they might bend or the soldered connections near the feedpoint may be damaged.

Additional EUT Data

Manufactured by	SPEAG
Manufactured on	July 05, 2002

DASY5 Validation Report for Head TSL

Date/Time: 17.02.2010 13:12:38

Test Laboratory: SPEAG, Zurich, Switzerland

DUT: Dipole 2450 MHz; Type: D2450V2; Serial: D2450V2 - SN:712

Communication System: CW; Frequency: 2450 MHz; Duty Cycle: 1:1

Medium: HSL U11 BB

Medium parameters used: $f = 2450$ MHz; $\sigma = 1.77$ mho/m; $\epsilon_r = 38.7$; $\rho = 1000$ kg/m³

Phantom section: Flat Section

Measurement Standard: DASY5 (IEEE/IEC/ANSI C63.19-2007)

DASY5 Configuration:

- Probe: ES3DV3 - SN3205; ConvF(4.53, 4.53, 4.53); Calibrated: 26.06.2009
- Sensor-Surface: 3mm (Mechanical Surface Detection)
- Electronics: DAE4 Sn601; Calibrated: 07.03.2009
- Phantom: Flat Phantom 5.0 (front); Type: QD000P50AA; Serial: 1001
- Measurement SW: DASY5, V5.2 Build 157; SEMCAD X Version 14.0 Build 57

Pin=250 mW /d=10mm, dist=3.0mm (ES-Probe)/Zoom Scan (7x7x7)/Cube 0: Measurement

grid: dx=5mm, dy=5mm, dz=5mm

Reference Value = 102.1 V/m; Power Drift = 0.032 dB

Peak SAR (extrapolated) = 27.2 W/kg

SAR(1 g) = 13.3 mW/g; SAR(10 g) = 6.24 mW/g

Maximum value of SAR (measured) = 17.1 mW/g

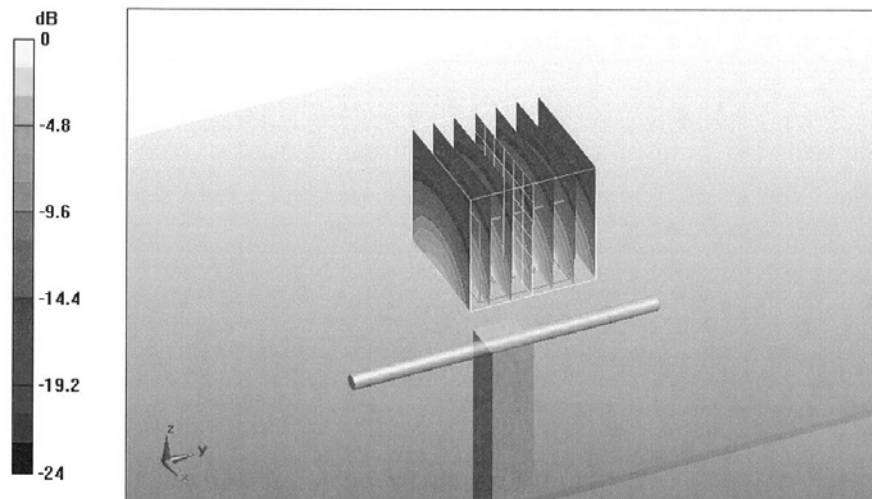

0 dB = 17.1mW/g

Impedance Measurement Plot for Head TSL

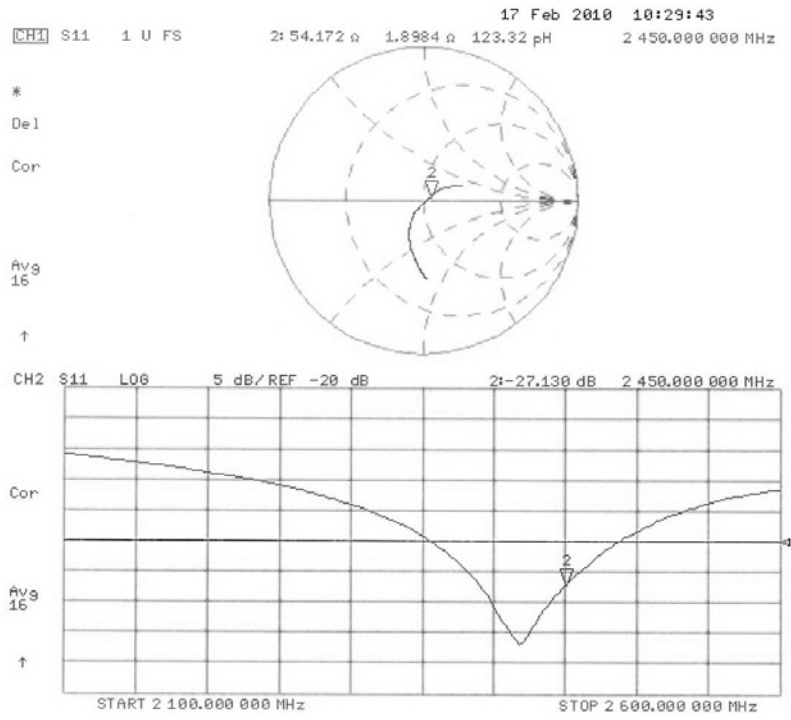

DASY5 Validation Report for Body

Date/Time: 19.02.2010 13:05:49

Test Laboratory: SPEAG, Zurich, Switzerland

DUT: Dipole 2450 MHz; Type: D2450V2; Serial: D2450V2 - SN:712

Communication System: CW; Frequency: 2450 MHz; Duty Cycle: 1:1

Medium: MSL U10 BB

Medium parameters used: $f = 2450$ MHz; $\sigma = 2.01$ mho/m; $\epsilon_r = 51.8$; $\rho = 1000$ kg/m³

Phantom section: Flat Section

Measurement Standard: DASY5 (IEEE/IEC/ANSI C63.19-2007)

DASY5 Configuration:

- Probe: ES3DV3 - SN3205; ConvF(4.31, 4.31, 4.31); Calibrated: 26.06.2009
- Sensor-Surface: 3mm (Mechanical Surface Detection)
- Electronics: DAE4 Sn601; Calibrated: 07.03.2009
- Phantom: Flat Phantom 5.0 (back); Type: QD000P50AA; Serial: 1002
- Measurement SW: DASY5, V5.2 Build 157; SEMCAD X Version 14.0 Build 57

Pin250 mW /d=10mm, dist=3.0mm (ES-Probe)/Zoom Scan (7x7x7)/Cube 0: Measurement

grid: dx=5mm, dy=5mm, dz=5mm

Reference Value = 94.5 V/m; Power Drift = 0.015 dB

Peak SAR (extrapolated) = 29.5 W/kg

SAR(1 g) = 13 mW/g; SAR(10 g) = 5.97 mW/g

Maximum value of SAR (measured) = 17 mW/g

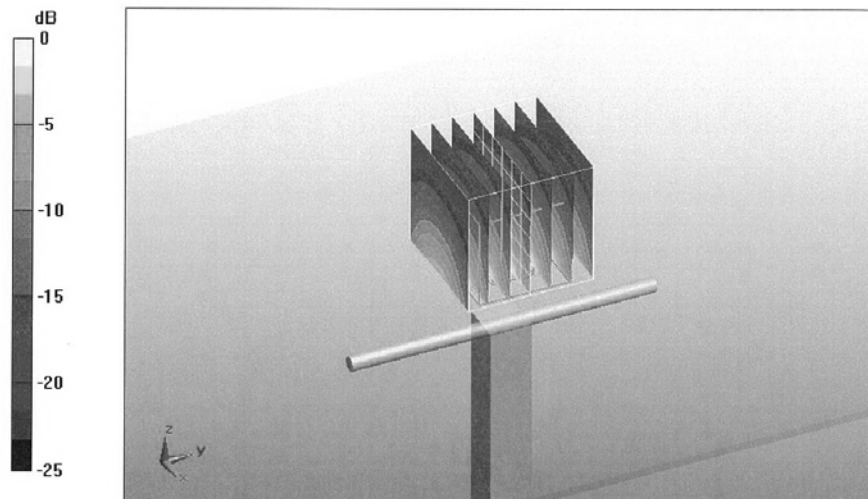

0 dB = 17mW/g

Impedance Measurement Plot for Body TSL

