



# FCC TEST REPORT

## (Part 24)

**REPORT NO.:** RF990429C05A-2  
**MODEL NO.:** EX128, EX122, EX126, EX124G  
**FCC ID:** IHDP56LJ2  
**RECEIVED:** May 24, 2010  
**TESTED:** Jul. 07 ~ Jul. 13, 2010  
**ISSUED:** Jul. 16, 2010

**APPLICANT:** Motorola Inc

**ADDRESS:** Mobile Devices 600 N. U.S. Highway 45,  
Libertyville, Illinois, United States, 60048-5343

**ISSUED BY:** Bureau Veritas Consumer Products Services  
(H.K.) Ltd., Taoyuan Branch

**LAB ADDRESS:** No. 47, 14th Ling, Chia Pau Tsuen, Lin Kou  
Hsiang, Taipei Hsien 244, Taiwan, R.O.C.

**TEST LOCATION:** No. 19, Hwa Ya 2nd Rd, Wen Hwa Tsuen, Kwei  
Shan Hsiang, Taoyuan Hsien 333, Taiwan, R.O.C.

This test report consists of 31 pages in total. It may be duplicated completely for legal use with the approval of the applicant. It should not be reproduced except in full, without the written approval of our laboratory. The client should not use it to claim product endorsement by TAF or any government agencies. The test results in the report only apply to the tested sample.



## TABLE OF CONTENTS

1	CERTIFICATION .....	3
2	SUMMARY OF TEST RESULTS .....	4
2.1	MEASUREMENT UNCERTAINTY .....	4
3	GENERAL INFORMATION.....	5
3.1	GENERAL DESCRIPTION OF EUT .....	5
3.2	DESCRIPTION OF TEST MODES.....	7
3.2.1	CONFIGURATION OF SYSTEM UNDER TEST .....	7
3.2.2	TEST MODE APPLICABILITY AND TESTED CHANNEL DETAIL.....	8
3.3	GENERAL DESCRIPTION OF APPLIED STANDARDS .....	9
3.4	DESCRIPTION OF SUPPORT UNITS .....	9
4	TEST TYPES AND RESULTS .....	10
4.1	OUTPUT POWER MEASUREMENT .....	10
4.1.1	LIMITS OF OUTPUT POWER MEASUREMENT .....	10
4.1.2	TEST INSTRUMENTS.....	11
4.1.3	TEST PROCEDURES .....	12
4.1.4	TEST SETUP.....	13
4.1.5	EUT OPERATING CONDITIONS .....	13
4.1.6	TEST RESULTS .....	14
4.2	RADIATED EMISSION MEASUREMENT (BELOW 1GHz).....	17
4.2.1	LIMITS OF RADIATED EMISSION MEASUREMENT .....	17
4.2.2	TEST INSTRUMENTS.....	17
4.2.3	TEST PROCEDURES .....	18
4.2.4	DEVIATION FROM TEST STANDARD .....	18
4.2.5	TEST SETUP.....	19
4.2.6	EUT OPERATING CONDITIONS .....	19
4.2.7	TEST RESULTS .....	20
4.3	RADIATED EMISSION MEASUREMENT (ABOVE 1GHz) .....	23
4.3.1	LIMITS OF RADIATED EMISSION MEASUREMENT.....	23
4.3.2	TEST INSTRUMENTS.....	23
4.3.3	TEST PROCEDURES .....	24
4.3.4	DEVIATION FROM TEST STANDARD .....	24
4.3.5	TEST SETUP.....	25
4.3.6	EUT OPERATING CONDITIONS .....	25
4.3.7	TEST RESULTS .....	26
5	PHOTOGRAPHS OF THE TEST CONFIGURATION.....	29
6	INFORMATION ON THE TESTING LABORATORIES .....	30
7	APPENDIX A – MODIFICATIONS RECORDERS FOR ENGINEERING CHANGES TO THE EUT BY THE LAB .....	31



# 1 CERTIFICATION

**PRODUCT:** GSM / EGPRS Mobile Phone  
**MODEL NO.:** EX128 (refer to item 3.1 for more detail)  
**BRAND:** MOTOROLA  
**APPLICANT:** Motorola Inc  
**TESTED:** Jul. 07 ~ Jul. 13, 2010  
**TEST SAMPLE:** ENGINEERING SAMPLE  
**TEST STANDARDS:** **FCC Part 24, Subpart E**  
ANSI C63.4-2003

This report is issued as a supplementary report of **RF990429C05-2**. This report shall be used combined together with its original report.

**PREPARED BY** : Pettie Chen , **DATE:** Jul. 16, 2010  
Pettie Chen / Specialist

**TECHNICAL ACCEPTANCE** : Long Chen , **DATE:** Jul. 16, 2010  
Responsible for RF Long Chen / Senior Engineer

**APPROVED BY** : Gary Chang , **DATE:** Jul. 16, 2010  
Gary Chang / Assistant Manager

**Note:** Only Output power & Radiated Emissions tests were performed for this addendum. Other testing data refer to original report.

## 2 SUMMARY OF TEST RESULTS

The EUT has been tested according to the following specifications:

APPLIED STANDARD: FCC Part 24 & Part 2 / IC RSS-133			
STANDARD SECTION	TEST TYPE AND LIMIT	RESULT	REMARK
2.1046 24.232	Maximum Peak Output Power Limit: max. 2 watts e.i.r.p peak power	PASS	Meet the requirement of limit. Minimum passing margin is 31.2dBm at 1880.0MHz.
2.1055 24.235	Frequency Stability AFC Freq. Error vs. Voltage AFC Freq. Error vs. Temperature Limit: max. $\pm 2.5$ ppm	NA	Not Applicable
2.1049 24.238(b)	Occupied Bandwidth	NA	Not Applicable
24.238(b)	Band Edge Measurements	NA	Not Applicable
2.1051 24.238	Conducted Spurious Emissions	NA	Not Applicable
2.1053 24.238	Radiated Spurious Emissions	PASS	Meet the requirement of limit. Minimum passing margin is $-29.9$ dB at 5640.0MHz.

**Note:** Only Output power & Radiated Emissions tests were performed for this addendum. Other testing data refer to original report.

### 2.1 MEASUREMENT UNCERTAINTY

Where relevant, the following measurement uncertainty levels have been estimated for tests performed on the EUT as specified in CISPR 16-4-2:

MEASUREMENT	FREQUENCY	UNCERTAINTY
Conducted emissions	150kHz~30MHz	2.44 dB
Radiated emissions	30MHz ~ 200MHz	3.34 dB
	200MHz ~1000MHz	3.35 dB
	1GHz ~ 18GHz	2.26 dB
	18GHz ~ 40GHz	1.94 dB

This uncertainty represents an expanded uncertainty expressed at approximately the 95% confidence level using a coverage factor of  $k=2$ .

### 3 GENERAL INFORMATION

#### 3.1 GENERAL DESCRIPTION OF EUT

<b>EUT</b>	GSM / EGPRS Mobile Phone
<b>MODEL NO.</b>	EX128 (Refer to Note for the more details)
<b>FCC ID</b>	IHDP56LJ2
<b>POWER SUPPLY</b>	3.7Vdc (battery) 5.0Vdc (adapter)
<b>MODULATION TYPE</b>	GMSK, 8PSK
<b>OPERATING FREQUENCY</b>	1850MHz ~ 1910MHz
<b>NUMBER OF CHANNEL</b>	299
<b>MAX. EIRP POWER</b>	GSM Mode: 31.2dBm (1.3183Watts)
<b>ANTENNA TYPE</b>	Embedded inverted-F
<b>MAX. ANTENNA GAIN</b>	2.4dBi
<b>ANTENNA CONNECTOR</b>	NA
<b>DATA CABLE</b>	NA
<b>I/O PORTS</b>	Refer to user's manual
<b>ACCESSORY DEVICES</b>	Adapter, Battery, Earphone (1. Model: SYN2356A, 1.3m shielded cable without core; 2. Model: SJYN0394A, 1.4m shielded cable without core)

**NOTE:**

1. This report is issued as a supplementary report to the original BVADT report no.: RF990429C05-2.
2. This report is prepared for FCC class II permissive change. Differences compared with the original report are listed as below.

ITEM	ORIGINAL DESCRIPTION	CLASS II CHANGE DESCRIPTION
1	Model: EX122, single SIM with Stylus.	- Model: EX126, single SIM without stylus. (for North America generic & WE) Model: EX124G, single SIM without stylus. (for TF) Change sound receiver, speaker and new housing without stylus.
2	Earphone (Model: SYN2356A, 1.3m shielded cable without core)	Add a new earphone. (Model: SJYN0394A, 1.4m shielded cable without core)
<p>** According to original report, the worst model EX128 and new model EX126 were selected for the final test configuration. Therefore, emission measurements listed as below had been re-tested.</p> <p>1. Model: EX128 with new earphone. 2. Model: EX126 with original and new earphone.</p>		

3. The communicated functions of EUT listed as below:

		850MHz	1900MHz	With Bluetooth 2.1+EDR function
2G	GSM	√	√	
	GPRS	√	√	
	EGPRS	√	√	

4. The EUT were tested with the following lithium battery and adapter:

LITHIUM BATTERY	
BRAND :	MOTOROLA
MODEL :	BQ50
RATING :	3.7Vdc, 910mAh, 3.4Wh

ADAPTER	
BRAND :	MOTOROLA
MODEL :	DCH3-050US-0303
INPUT :	100-240Vac, 50/60Hz, 0.2A
OUTPUT :	5Vdc, 550mA

5. The test data are separated into following test reports.

	TEST STANDARD	REFERENCE REPORT
BLUETOOTH	FCC Part 15, Subpart C (Section 15.247)	RF990429C05A
GSM 850	FCC Part 22	RF990429C05A-1
PCS 1900	FCC Part 24	RF990429C05A-2

6. IMEI Code: IMEI (1): 35156604004346-0, IMEI (2): 35156604004712-3.

IMEI (1):35156604004366-8

7. Software vision: 7S82070000-002-R1J.

8. Hardware vision: EP1.

9. The above EUT information was declared by manufacturer and for more detailed features description, please refer to the manufacturer's specifications or User's Manual.

### 3.2 DESCRIPTION OF TEST MODES

299 channels are provided to this EUT. The middle channel is chosen for testing.

	CHANNEL	FREQUENCY	TX MODE
<b>MIDDLE</b>	661	1880.0 MHz	GSM

**NOTE:**

1. Below 1 GHz, the channel 661 was tested individually.
2. Above 1 GHz, the channel 661 was tested individually.
3. The worst case for final test is chosen when the power control level set 0.
4. The channel space is 0.2MHz.
5. The EUT has GSM, GPRS & EGPRS functions. GSM function is the worst case for all the emission tests.

#### 3.2.1 CONFIGURATION OF SYSTEM UNDER TEST

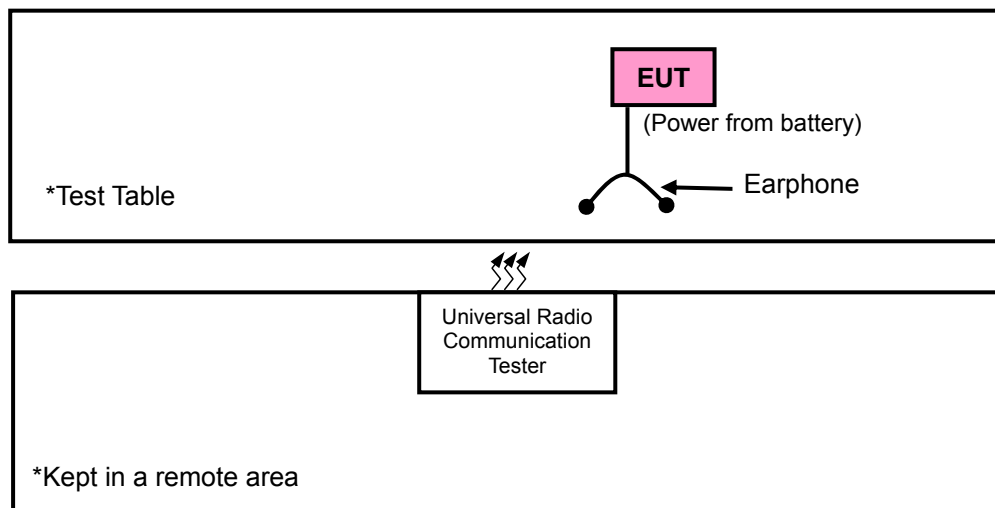

### 3.2.2 TEST MODE APPLICABILITY AND TESTED CHANNEL DETAIL

EUT CONFIGURE MODE	APPLICABLE TO			DESCRIPTION
	OP	RE<1G	RE≥1G	
A	√	√	√	EUT model: EX128 with earphone: SJYN0394A
B	√	√	√	EUT model: EX126 with earphone: SYN2356A
C	√	√	√	EUT model: EX126 with earphone: SJYN0394A

Where **OP**: Output power **RE<1G**: Radiated emission below 1GHz  
**RE≥1G**: Radiated emission above 1GHz

#### **OUTPUT POWER MEASUREMENT:**

- Pre-Scan has been conducted to determine the worst-case mode from all possible combinations between available modulations, XYZ axis and antenna ports (if EUT with antenna diversity architecture).
- Following channel(s) was (were) selected for the final test as listed below.

EUT CONFIGURE MODE	AVAILABLE CHANNEL	TESTED CHANNEL	MODULATION TECHNOLOGY	AXIS
A, B, C	512 to 810	661	GSM	X

#### **RADIATED EMISSION MEASUREMENT (BELOW 1 GHz):**

- Pre-Scan has been conducted to determine the worst-case mode from all possible combinations between available modulations, XYZ axis and antenna ports (if EUT with antenna diversity architecture).
- Following channel(s) was (were) selected for the final test as listed below.

EUT CONFIGURE MODE	AVAILABLE CHANNEL	TESTED CHANNEL	MODULATION TECHNOLOGY	AXIS
A, B, C	512 to 810	661	GSM	X

#### **RADIATED EMISSION MEASUREMENT (ABOVE 1 GHz):**

- Pre-Scan has been conducted to determine the worst-case mode from all possible combinations between available modulations, XYZ axis and antenna ports (if EUT with antenna diversity architecture).
- Following channel(s) was (were) selected for the final test as listed below.

EUT CONFIGURE MODE	AVAILABLE CHANNEL	TESTED CHANNEL	MODULATION TECHNOLOGY	AXIS
A, B, C	512 to 810	661	GSM	X



**TEST CONDITION:**

APPLICABLE TO	ENVIRONMENTAL CONDITIONS	INPUT POWER	TESTED BY
OP	26deg. C, 66%RH, 1008 hPa	3.7Vdc	Brad Wu
RE < 1G	25deg. C, 65%RH, 1001 hPa	3.7Vdc	Brad Wu
RE ≥ 1G	25deg. C, 65%RH, 1001 hPa	3.7Vdc	Brad Wu

### 3.3 GENERAL DESCRIPTION OF APPLIED STANDARDS

The EUT is a RF product. According to the specifications of the manufacturer, it must comply with the requirements of the following standards:

**FCC 47 CFR Part 2**

**FCC 47 CFR Part 24**

**IC RSS-133**

**ANSI C63.4-2003**

**ANSI/TIA/EIA-603-C 2004**

**NOTE:** All test items have been performed and recorded as per the above standards.

### 3.4 DESCRIPTION OF SUPPORT UNITS

The EUT has been tested as an independent unit together with other necessary accessories or support units. The following support units or accessories were used to form a representative test configuration during the tests.

NO.	PRODUCT	BRAND	MODEL NO.	SERIAL NO.	FCC ID
1	UNIVERSAL RADIO COMMUNICATION TESTER	R&S	CMU200	104484	NA

NO.	SIGNAL CABLE DESCRIPTION OF THE ABOVE SUPPORT UNITS
1	NA

**NOTE 1:** All power cords of the above support units are non shielded (1.8m).

**NOTE 2:** Item 1 acted as a communication partner to transfer data.

## 4 TEST TYPES AND RESULTS

### 4.1 OUTPUT POWER MEASUREMENT

#### 4.1.1 LIMITS OF OUTPUT POWER MEASUREMENT

The radiated peak output power shall be according to the specific rule Part 24.232(b) that “Mobile / Portable station are limited to 2 watts e.i.r.p” and 24.232(c) specific that “Peak transmit power must be measure over any interval of continuous transmission using instrumentation calibration in terms of rms-equivalent voltage.”

#### 4.1.2 TEST INSTRUMENTS

DESCRIPTION & MANUFACTURER	MODEL NO.	SERIAL NO.	DATE OF CALIBRATION	DUE DATE OF CALIBRATION
Test Receiver ROHDE & SCHWARZ	ESIB7	100188	Dec. 21, 2009	Dec. 20, 2010
Spectrum Analyzer ROHDE & SCHWARZ	FSP40	100269	Dec. 31, 2009	Dec. 30, 2010
BILOG Antenna SCHWARZBECK	VULB9168	9168-160	Apr. 27, 2010	Apr. 26, 2011
HORN Antenna SCHWARZBECK	9120D	9120D-405	Feb. 03, 2010	Feb. 02, 2011
HORN Antenna SCHWARZBECK	BBHA 9170	BBHA9170243	Dec. 25, 2009	Dec. 24, 2010
Preamplifier Agilent	8447D	2944A10633	Nov. 10, 2009	Nov. 09, 2010
Preamplifier Agilent	8449B	3008A01964	Nov. 09, 2009	Nov. 08, 2010
RF signal cable HUBER+SUHNNER	SUCOFLEX 104	238141/4	May 14, 2010	May 13, 2011
RF signal cable HUBER+SUHNNER	SUCOFLEX 104	12738/6	May 14, 2010	May 13, 2011
Software ADT.	ADT_Radiated_ V7.6.15.9.2	NA	NA	NA
Antenna Tower inn-co GmbH	MA 4000	013303	NA	NA
Antenna Tower Controller inn-co GmbH	CO2000	017303	NA	NA
Turn Table ADT.	TT100.	TT93021703	NA	NA
Turn Table Controller ADT.	SC100.	SC93021703	NA	NA

- NOTE:**
1. The calibration interval of the above test instruments is 12 months and the calibrations are traceable to NML/ROC and NIST/USA.
  2. The test was performed in HwaYa Chamber 3.
  3. The horn antenna and HP preamplifier (model: 8449B) are used only for the measurement of emission frequency above 1GHz if tested.
  4. The FCC Site Registration No. is 988962.
  5. The IC Site Registration No. is IC 7450F-3.

#### 4.1.3 TEST PROCEDURES

- a. The power was measured with R&S Spectrum Analyzer. All measurements were done at 1 channel, 661 (middle operational frequency range.)
- b. The conducted peak output power used the power splitter via EUT RF power connector between simulation base station and spectrum analyzer. The path loss included the splitter loss, cable loss and 20dB pad loss. The spectrum set RB/VB 1MHz, then read peak power value and record to the test. (All transmitted path loss shall be considered in the test report data.)
- c. Substitution method is used for E.I.R.P measurement. In the semi-anechoic chamber, EUT placed on the 0.8m height of Turn Table, rotated the table around 360 degrees to search the maximum radiation power and receiver antenna shall be rotated vertical and horizontal polarization and moved height from 1m to 4m to find the maximum polar radiated power. The “Read Value” is the spectrum reading the maximum power value.
- d. The substitution horn antenna is substituted for EUT at the same position and signals generator export the CW signal to the substitution antenna via a tx cable. Rotated the Turn Table and moved receiving antenna to find the maximum radiation power. Adjust output power level of S.G to get a Value of spectrum reading equal to “Read Value ” of step c. Record the power level of S.G
- e.  $EIRP = \text{Output power level of S.G} - \text{TX cable loss} + \text{Antenna gain of substitution horn.}$

#### 4.1.4 TEST SETUP

##### EIRP POWER MEASUREMENT:

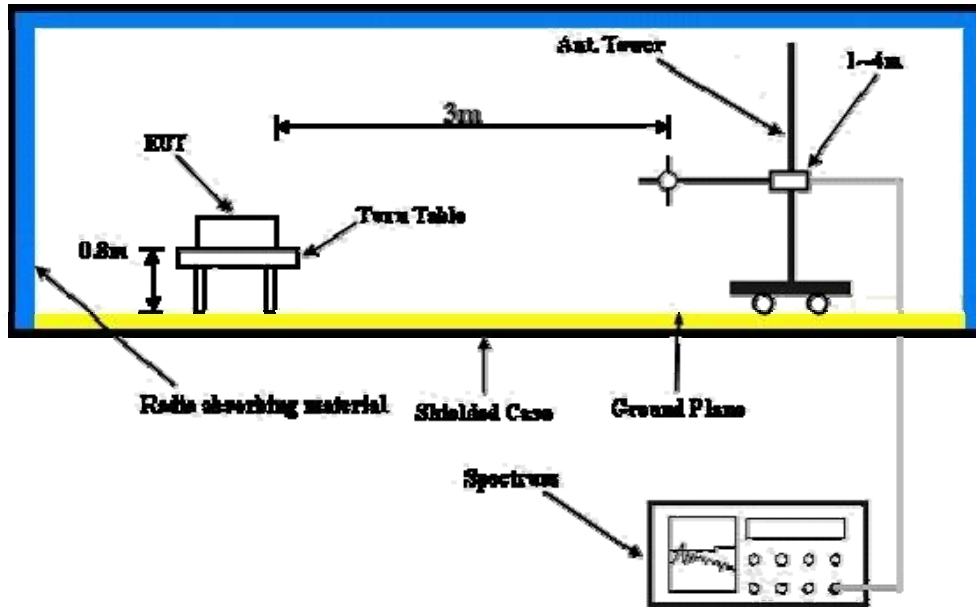

For the actual test configuration, please refer to the attached file (Test Setup Photo).

##### CONDUCTED POWER MEASUREMENT:

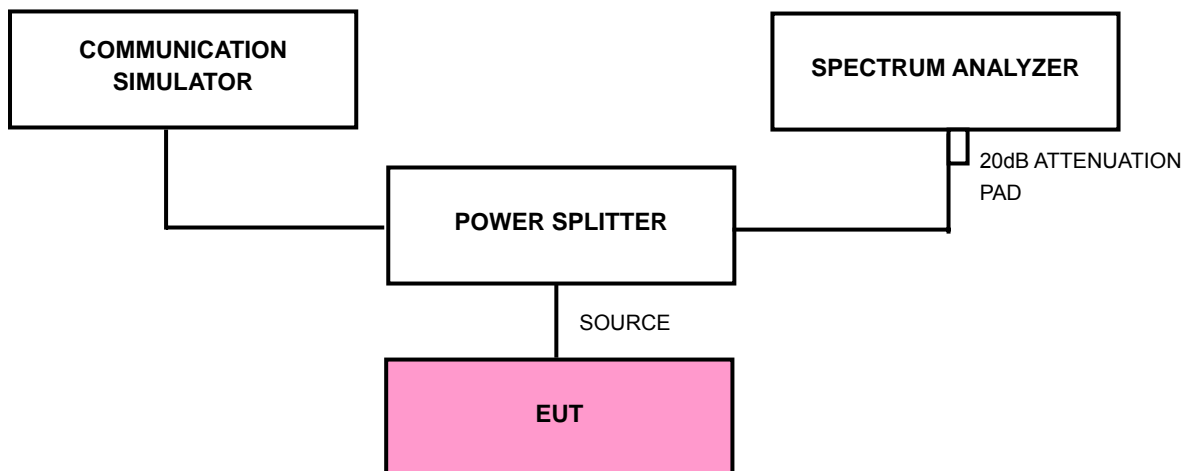

For the actual test configuration, please refer to the related item – Photographs of the Test Configuration.

#### 4.1.5 EUT OPERATING CONDITIONS

- a. The EUT makes a phone call to the communication simulator.
- b. The communication simulator station system controlled an EUT to export maximum output power under transmission mode and specific channel frequency.

#### 4.1.6 TEST RESULTS

##### TEST MODE A

##### FOR GSM MODE

CONDUCTED OUTPUT POWER					
CHANNEL NO.	FREQUENCY (MHz)	RAW VALUE (dBm)	CORRECTION FACTOR (dB)	OUTPUT POWER	
				dBm	Watt
661	1880	5.10	24.50	29.60	0.912

**REMARKS:** 1. Peak Output Power (dBm) = Raw Value (dBm) + Correction Factor (dB).  
 2. Correction Factor (dB) = Power Splitter Loss (dB) + Cable Loss (dB).

##### FOR GSM MODE

EIRP POWER					
CHANNEL NO.	FREQUENCY (MHz)	S.G VALUE (dBm)	CORRECTION FACTOR (dB)	OUTPUT POWER	
				dBm	Watt
661	1880	22.6	8.6	31.2	0.1318

**REMARKS:** 1. Peak Output Power (dBm) = S.G Value (dBm) + Correction Factor (dB).  
 2. Correction Factor (dB) = Substitution Antenna Gain (dB) + Cable Loss (dB).

**TEST MODE B**
**FOR GSM MODE**

CONDUCTED OUTPUT POWER					
CHANNEL NO.	FREQUENCY (MHz)	RAW VALUE (dBm)	CORRECTION FACTOR (dB)	OUTPUT POWER	
				dBm	Watt
661	1880	4.95	24.50	29.45	0.881

**REMARKS:** 1. Peak Output Power (dBm) = Raw Value (dBm) + Correction Factor (dB).  
 2. Correction Factor (dB) = Power Splitter Loss (dB) + Cable Loss (dB).

**FOR GSM MODE**

EIRP POWER					
CHANNEL NO.	FREQUENCY (MHz)	S.G VALUE (dBm)	CORRECTION FACTOR (dB)	OUTPUT POWER	
				dBm	Watt
661	1880	22.1	8.6	30.7	0.11749

**REMARKS:** 1. Peak Output Power (dBm) = S.G Value (dBm) + Correction Factor (dB).  
 2. Correction Factor (dB) = Substitution Antenna Gain (dB) + Cable Loss (dB).

**TEST MODE C**

**FOR GSM MODE**

CONDUCTED OUTPUT POWER					
CHANNEL NO.	FREQUENCY (MHz)	RAW VALUE (dBm)	CORRECTION FACTOR (dB)	OUTPUT POWER	
				dBm	Watt
661	1880	4.95	24.50	29.45	0.881

**REMARKS:** 1. Peak Output Power (dBm) = Raw Value (dBm) + Correction Factor (dB).  
 2. Correction Factor (dB) = Power Splitter Loss (dB) + Cable Loss (dB).

**FOR GSM MODE**

EIRP POWER					
CHANNEL NO.	FREQUENCY (MHz)	S.G VALUE (dBm)	CORRECTION FACTOR (dB)	OUTPUT POWER	
				dBm	Watt
661	1880	21.7	8.6	30.3	0.10715

**REMARKS:** 1. Peak Output Power (dBm) = S.G Value (dBm) + Correction Factor (dB).  
 2. Correction Factor (dB) = Substitution Antenna Gain (dB) + Cable Loss (dB).

## 4.2 RADIATED EMISSION MEASUREMENT (BELOW 1GHz)

### 4.2.1 LIMITS OF RADIATED EMISSION MEASUREMENT

In the FCC 24.238(a), On any frequency outside a licensee's frequency block within USPCS spectrum, the power of any emission shall be attenuated below the transmitter power (P) by at least  $43 + 10 \log (P)$  dB. The emission of limit equal to  $-13$ dBm. So the limit of emission is the same absolute specified line.

LIMIT (dBm)	EQUIVALENT FIELD STRENGTH AT 3m (dBuV/m) (NOTE)
-13	82.2

**NOTE:** The following formula is used to convert the equipment radiated power to field strength.

$$E = [1000000\sqrt{(30P)}] / 3 \text{ uV/m, where P is Watts.}$$

### 4.2.2 TEST INSTRUMENTS

Same as 4.1.2.

#### 4.2.3 TEST PROCEDURES

- a. The EUT was placed on the top of a rotating table 0.8 meters above the ground at a 3 meters semi-anechoic chamber. The table was rotated 360 degrees to determine the position of the highest radiation.
- b. The EUT was set 3 meters away from the interference-receiving antenna, which was mounted on the top of a variable-height antenna tower.
- c. The antenna is a broadband antenna, and its height is varied from one meter to four meters above the ground to determine the maximum value of the field strength. Both horizontal and vertical polarizations of the antenna are set to make the measurement.
- d. For each suspected emission, the EUT was arranged to its worst case and then the antenna was tuned to heights from 1 meter to 4 meters and the rotatable table was turned from 0 degrees to 360 degrees to find the maximum reading.
- e. The test-receiver system was set to Peak Detect Function and Specified Bandwidth with Maximum Hold Mode.
- f. If the emission level of the EUT in peak mode was lower than the limit specified, then testing could be stopped and the peak values of the EUT would be reported. Otherwise the emissions would be re-tested one by one using peak, quasi-peak or average method as specified and then reported in a data sheet.

**NOTE:** The resolution bandwidth of spectrum analyzer is 1 MHz and the video bandwidth is 3 MHz.

#### 4.2.4 DEVIATION FROM TEST STANDARD

No deviation

#### 4.2.5 TEST SETUP

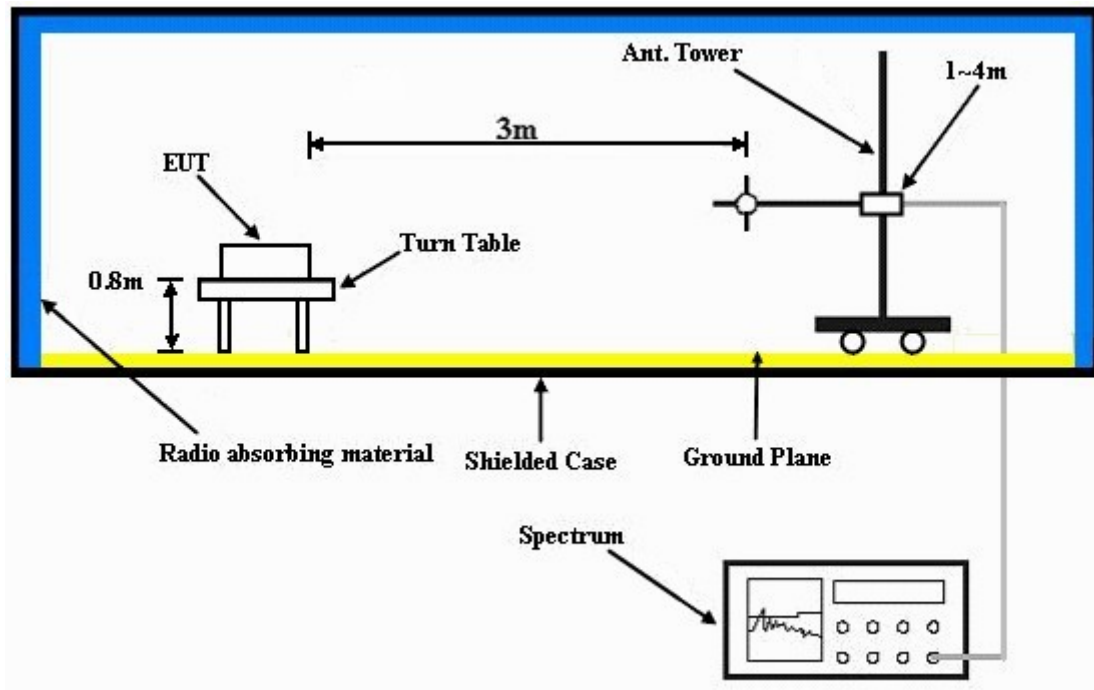

For the actual test configuration, please refer to the attached file (Test Setup Photo).

#### 4.2.6 EUT OPERATING CONDITIONS

- a. The EUT makes a phone call to the communication simulator.
- b. The communication simulator station system controlled an EUT to export maximum output power under transmission mode and specific channel frequency.

## 4.2.7 TEST RESULTS

### TEST MODE A

<b>MODE</b>	TX channel 661	<b>DETECTOR FUNCTION</b>	Peak
-------------	----------------	--------------------------	------

ANTENNA POLARITY & TEST DISTANCE: HORIZONTAL AT 3 M								
NO.	FREQ. (MHz)	EMISSION LEVEL (dBuV/m)	LIMIT (dBuV/m)	MARGIN (dB)	ANTENNA HEIGHT (m)	TABLE ANGLE (Degree)	RAW VALUE (dBuV)	CORRECTION FACTOR (dB/m)
1	72.77	31.8	82.2	-50.5	2.00 H	295	19.90	11.90
2	185.51	35.3	82.2	-47.0	2.00 H	76	24.00	11.30
3	337.13	27.1	82.2	-55.2	2.00 H	265	11.70	15.40
4	416.83	29.0	82.2	-53.3	1.00 H	295	10.50	18.50
5	527.64	30.8	82.2	-51.5	1.00 H	10	9.70	21.10
6	655.93	32.4	82.2	-49.9	1.00 H	115	8.40	24.00
ANTENNA POLARITY & TEST DISTANCE: VERTICAL AT 3 M								
NO.	FREQ. (MHz)	EMISSION LEVEL (dBuV/m)	LIMIT (dBuV/m)	MARGIN (dB)	ANTENNA HEIGHT (m)	TABLE ANGLE (Degree)	RAW VALUE (dBuV)	CORRECTION FACTOR (dB/m)
1	72.77	34.6	82.2	-47.7	1.00 V	103	22.70	11.90
2	158.30	34.9	82.2	-47.4	2.00 V	97	20.60	14.30
3	356.57	26.3	82.2	-56.0	1.50 V	52	10.00	16.30
4	457.66	29.1	82.2	-53.2	2.00 V	229	9.60	19.50
5	535.41	31.6	82.2	-50.7	2.00 V	262	10.40	21.20
6	576.23	30.7	82.2	-51.6	1.50 V	241	8.70	22.00

#### NOTE:

1. Emission level (dBuV/m) = Raw Value (dBuV) + Correction Factor (dB).
2. Correction Factor (dB/m) = Antenna Factor (dB/m) + Cable Factor (dB).
3. The other emission levels were very low against the limit.
4. Margin value = Emission level – Limit value.
5. This is valid for 1 channel.

**TEST MODE B**

<b>MODE</b>	TX channel 661	<b>DETECTOR FUNCTION</b>	Peak
-------------	----------------	--------------------------	------

<b>ANTENNA POLARITY &amp; TEST DISTANCE: HORIZONTAL AT 3 M</b>								
NO.	FREQ. (MHz)	EMISSION LEVEL (dBuV/m)	LIMIT (dBuV/m)	MARGIN (dB)	ANTENNA HEIGHT (m)	TABLE ANGLE (Degree)	RAW VALUE (dBuV)	CORRECTION FACTOR (dB/m)
1	72.77	30.5	82.2	-51.8	1.50 H	127	18.60	11.90
2	175.79	25.2	82.2	-57.1	1.00 H	238	12.00	13.20
3	486.81	29.4	82.2	-52.9	1.00 H	118	9.20	20.20
4	657.88	32.9	82.2	-49.4	1.50 H	241	8.90	24.00
5	757.01	34.2	82.2	-48.1	1.00 H	244	8.60	25.60
6	846.43	36.4	82.2	-45.9	1.50 H	154	9.50	26.90
<b>ANTENNA POLARITY &amp; TEST DISTANCE: VERTICAL AT 3 M</b>								
NO.	FREQ. (MHz)	EMISSION LEVEL (dBuV/m)	LIMIT (dBuV/m)	MARGIN (dB)	ANTENNA HEIGHT (m)	TABLE ANGLE (Degree)	RAW VALUE (dBuV)	CORRECTION FACTOR (dB/m)
1	31.94	36.8	82.2	-45.5	1.00 V	184	23.60	13.20
2	72.77	35.4	82.2	-46.9	1.50 V	274	23.50	11.90
3	203.01	36.1	82.2	-46.2	1.00 V	10	25.40	10.70
4	457.66	29.1	82.2	-53.2	1.00 V	94	9.60	19.50
5	609.28	31.7	82.2	-50.6	1.50 V	199	9.00	22.70
6	830.88	34.5	82.2	-47.8	1.00 V	118	7.90	26.60

**NOTE:**

1. Emission level (dBuV/m) = Raw Value (dBuV) + Correction Factor (dB).
2. Correction Factor (dB/m) = Antenna Factor (dB/m) + Cable Factor (dB).
3. The other emission levels were very low against the limit.
4. Margin value = Emission level – Limit value.
5. This is valid for 1 channel.

**TEST MODE C**

<b>MODE</b>	TX channel 661	<b>DETECTOR FUNCTION</b>	Peak
-------------	----------------	--------------------------	------

<b>ANTENNA POLARITY &amp; TEST DISTANCE: HORIZONTAL AT 3 M</b>								
NO.	FREQ. (MHz)	EMISSION LEVEL (dBuV/m)	LIMIT (dBuV/m)	MARGIN (dB)	ANTENNA HEIGHT (m)	TABLE ANGLE (Degree)	RAW VALUE (dBuV)	CORRECTION FACTOR (dB/m)
1	70.82	29.2	82.2	-53.1	1.00 H	112	16.30	12.90
2	195.23	23.9	82.2	-58.4	1.00 H	229	13.10	10.80
3	370.18	26.3	82.2	-56.0	1.50 H	160	9.50	16.80
4	562.63	31.4	82.2	-50.9	1.00 H	115	9.60	21.80
5	725.91	34.6	82.2	-47.7	1.00 H	241	9.30	25.30
6	755.07	34.4	82.2	-47.9	1.50 H	352	8.80	25.60
<b>ANTENNA POLARITY &amp; TEST DISTANCE: VERTICAL AT 3 M</b>								
NO.	FREQ. (MHz)	EMISSION LEVEL (dBuV/m)	LIMIT (dBuV/m)	MARGIN (dB)	ANTENNA HEIGHT (m)	TABLE ANGLE (Degree)	RAW VALUE (dBuV)	CORRECTION FACTOR (dB/m)
1	53.33	34.3	82.2	-48.0	1.00 V	64	21.20	13.10
2	98.04	29.2	82.2	-53.1	1.00 V	289	18.30	10.90
3	243.83	33.5	82.2	-48.8	1.50 V	97	20.00	13.50
4	494.59	30.2	82.2	-52.1	1.00 V	283	9.80	20.40
5	626.77	33.0	82.2	-49.3	1.50 V	343	9.80	23.20
6	708.42	33.9	82.2	-48.4	1.00 V	106	8.70	25.20

**NOTE:**

1. Emission level (dBuV/m) = Raw Value (dBuV) + Correction Factor (dB).
2. Correction Factor (dB/m) = Antenna Factor (dB/m) + Cable Factor (dB).
3. The other emission levels were very low against the limit.
4. Margin value = Emission level – Limit value.
5. This is valid for 1 channel.

### **4.3 RADIATED EMISSION MEASUREMENT (ABOVE 1GHz)**

#### **4.3.1 LIMITS OF RADIATED EMISSION MEASUREMENT**

In the FCC 24.238(a), On any frequency outside a licensee's frequency block within USPCS spectrum, the power of any emission shall be attenuated below the transmitter power (P) by at least  $43 + 10 \log (P)$  dB. The specified minimum attenuation becomes 43dB and the limit of emission equal to  $-13\text{dBm}$ .

#### **4.3.2 TEST INSTRUMENTS**

Same as 4.1.2.

#### 4.3.3 TEST PROCEDURES

- a. Substitution method is used for E.I.R.P measurement. In the semi-anechoic chamber, EUT placed on the 0.8m height of Turn Table, rotated the table around 360 degrees to search the maximum radiation power and receiver antenna shall be rotated vertical and horizontal polarization and moved height from 1m to 4m to find the maximum polar radiated power. The “Read Value” is the spectrum reading the maximum power value.
- b. The substitution horn antenna is substituted for EUT at the same position and signals generator export the CW signal to the substitution antenna via a TX cable. Rotated the Turn Table and moved receiving antenna to find the maximum radiation power. Adjust output power level of S.G to get a Value of spectrum reading equal to “Read Value ” of step a. Record the power level of S.G
- c.  $EIRP = \text{Output power level of S.G} - \text{TX cable loss} + \text{Antenna gain of substitution horn.}$

**NOTE:** The resolution bandwidth and video bandwidth of test receiver/spectrum analyzer is 1MHz/3MHz.

#### 4.3.4 DEVIATION FROM TEST STANDARD

No deviation

#### 4.3.5 TEST SETUP

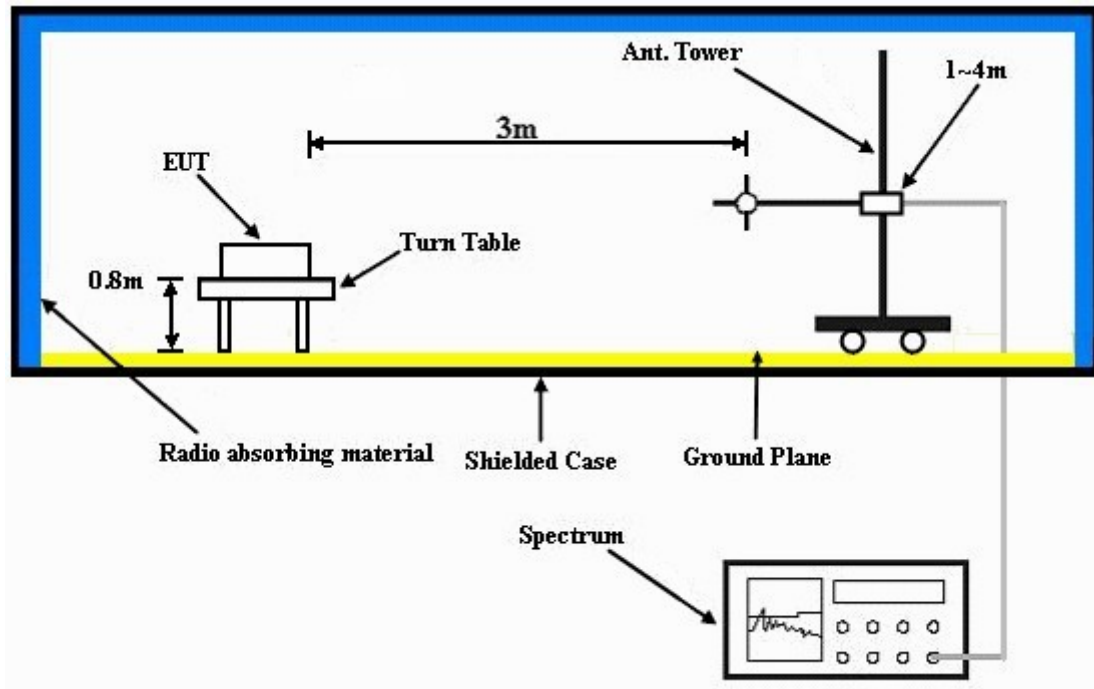

For the actual test configuration, please refer to the attached file (Test Setup Photo).

#### 4.3.6 EUT OPERATING CONDITIONS

- a. The EUT makes a phone call to the communication simulator.
- b. The communication simulator station system controlled an EUT to export maximum output power under transmission mode and specific channel frequency.

### 4.3.7 TEST RESULTS

#### TEST MODE A

<b>MODE</b>	TX channel 661	<b>FREQUENCY RANGE</b>	Above 1000 MHz
-------------	----------------	------------------------	----------------

ANTENNA POLARITY & TEST DISTANCE: HORIZONTAL AT 3 M						
No.	Freq. (MHz)	Emission Level (dBuV)	Limit (dBm)	S.G Power Value (dBm)	Correction Factor (dB)	Power Value (dBm)
1	3760	47.6	-13.0	-57.1	9.9	-47.2
2	5640	51.8	-13.0	-52.5	9.6	-42.9
ANTENNA POLARITY & TEST DISTANCE: VERTICAL AT 3 M						
No.	Freq. (MHz)	Emission Level (dBuV)	Limit (dBm)	S.G Power Value (dBm)	Correction Factor (dB)	Power Value (dBm)
1	3760	46.7	-13.0	-57.9	9.9	-48.0
2	5640	50.9	-13.0	-53.5	9.6	-43.9

**NOTE:** Power Value (dBum) = S.G Power Value (dBm) + Correction Factor (dB).



### TEST MODE B

<b>MODE</b>	TX channel 661	<b>FREQUENCY RANGE</b>	Above 1000 MHz
-------------	----------------	------------------------	----------------

ANTENNA POLARITY & TEST DISTANCE: HORIZONTAL AT 3 M						
No.	Freq. (MHz)	Emission Level (dBuV)	Limit (dBm)	S.G Power Value (dBm)	Correction Factor (dB)	Power Value (dBm)
1	3760	46.5	-13.0	-58.2	9.9	-48.3
2	5640	49.5	-13.0	-54.8	9.6	-45.2
ANTENNA POLARITY & TEST DISTANCE: VERTICAL AT 3 M						
No.	Freq. (MHz)	Emission Level (dBuV)	Limit (dBm)	S.G Power Value (dBm)	Correction Factor (dB)	Power Value (dBm)
1	3760	46.0	-13.0	-58.6	9.9	-48.7
2	5640	50.2	-13.0	-54.2	9.6	-44.6

**NOTE:** Power Value (dBum) = S.G Power Value (dBm) + Correction Factor (dB).



### TEST MODE C

<b>MODE</b>	TX channel 661	<b>FREQUENCY RANGE</b>	Above 1000 MHz
-------------	----------------	------------------------	----------------

ANTENNA POLARITY & TEST DISTANCE: HORIZONTAL AT 3 M						
No.	Freq. (MHz)	Emission Level (dBuV)	Limit (dBm)	S.G Power Value (dBm)	Correction Factor (dB)	Power Value (dBm)
1	3760	46.2	-13.0	-58.5	9.9	-48.6
2	5640	49.1	-13.0	-55.2	9.6	-45.6
ANTENNA POLARITY & TEST DISTANCE: VERTICAL AT 3 M						
No.	Freq. (MHz)	Emission Level (dBuV)	Limit (dBm)	S.G Power Value (dBm)	Correction Factor (dB)	Power Value (dBm)
1	3760	45.5	-13.0	-59.1	9.9	-49.2
2	5640	49.6	-13.0	-54.8	9.6	-45.2

**NOTE:** Power Value (dBum) = S.G Power Value (dBm) + Correction Factor (dB).

## 5 PHOTOGRAPHS OF THE TEST CONFIGURATION

Please refer to the attached file (Test Setup Photo).



## 6 INFORMATION ON THE TESTING LABORATORIES

We, Bureau Veritas Consumer Products Services (H.K.) Ltd., Taoyuan Branch, were founded in 1988 to provide our best service in EMC, Radio, Telecom and Safety consultation. Our laboratories are accredited and approved according to ISO/IEC 17025.

Copies of accreditation certificates of our laboratories obtained from approval agencies can be downloaded from our web site: [www.adt.com.tw/index.5/phtml](http://www.adt.com.tw/index.5/phtml). If you have any comments, please feel free to contact us at the following:

**Linko EMC/RF Lab:**

Tel: 886-2-26052180

Fax: 886-2-26051924

**Hsin Chu EMC/RF Lab:**

Tel: 886-3-5935343

Fax: 886-3-5935342

**Hwa Ya EMC/RF/Safety/Telecom Lab:**

Tel: 886-3-3183232

Fax: 886-3-3185050

**Web Site:** [www.adt.com.tw](http://www.adt.com.tw)

The address and road map of all our labs can be found in our web site also.

## **7 APPENDIX A – MODIFICATIONS RECORDERS FOR ENGINEERING CHANGES TO THE EUT BY THE LAB**

No any modifications are made to the EUT by the lab during the test.

**---END---**