



A D T

SAR TEST REPORT

REPORT NO.: SA990429C05

MODEL NO.: EX128, EX122

RECEIVED: Apr. 29, 2010

TESTED: May 11 ~ May 24, 2010

ISSUED: May 27, 2010

APPLICANT: Motorola Inc

ADDRESS: Mobile Devices 600 N. U.S. Highway 45,
Libertyville, Illinois, United States, 60048-5343

ISSUED BY: Bureau Veritas Consumer Products Services (H.K.)
Ltd., Taoyuan Branch

LAB ADDRESS: No. 47, 14th Ling, Chia Pau Tsuen, Lin Kou Hsiang,
Taipei Hsien 244, Taiwan, R.O.C.

TEST LOCATION: No. 19, Hwa Ya 2nd Rd, Wen Hwa Tsuen, Kwei
Shan Hsiang, Taoyuan Hsien 333, Taiwan, R.O.C.

This test report consists of 30 pages in total except Appendix. It may be duplicated completely for legal use with the approval of the applicant. It should not be reproduced except in full, without the written approval of our laboratory. The client should not use it to claim product endorsement by TAF or any government agencies. The test results in the report only apply to the tested sample.





TABLE OF CONTENTS

1.	CERTIFICATION	3
2.	GENERAL INFORMATION	4
2.1	GENERAL DESCRIPTION OF EUT.....	4
2.2	GENERAL DESCRIPTION OF APPLIED STANDARDS.....	5
2.3	GENERAL INFORMATION OF THE SAR SYSTEM	6
2.4	TEST EQUIPMENT	9
2.5	GENERAL DESCRIPTION OF THE SPATIAL PEAK SAR EVALUATION	10
3.	DESCRIPTION OF SUPPORT UNITS.....	13
4.	RECIPES FOR TISSUE SIMULATING LIQUIDS	14
5.	SYSTEM VALIDATION.....	21
5.1	TEST PROCEDURE	21
5.2	VALIDATION RESULTS	23
5.3	SYSTEM VALIDATION UNCERTAINTIES	24
6.	TEST RESULTS	25
6.1	TEST PROCEDURES.....	25
6.2	DESCRIPTION OF TEST CONDITION.....	26
6.3	MEASURED SAR RESULT	27
6.4	SAR LIMITS	29
7.	INFORMATION ON THE TESTING LABORATORIES.....	30
	APPENDIX A: TEST CONFIGURATIONS AND TEST DATA	
	APPENDIX B: ADT SAR MEASUREMENT SYSTEM	
	APPENDIX C: PHOTOGRAPHS OF SYSTEM VALIDATION	
	APPENDIX D: SYSTEM CERTIFICATE & CALIBRATION	



1. CERTIFICATION

PRODUCT: GSM / EGPRS Mobile Phone
MODEL NO.: EX128 (refer to item 2.1 for more detail)
BRAND: Motorola
APPLICANT: Motorola Inc
TESTED: May 11 ~ May 24, 2010
TEST SAMPLE: ENGINEERING SAMPLE
STANDARDS: **FCC Part 2 (Section 2.1093)**
FCC OET Bulletin 65, Supplement C (01-01)
RSS-102

The above equipment (model: EX128, EX122) has been tested by **Bureau Veritas Consumer Products Services (H.K.) Ltd., Taoyuan Branch**, and found compliance with the requirement of the above standards. The test record, data evaluation & Equipment Under Test (EUT) configurations represented herein are true and accurate accounts of the measurements of the sample's EMC characteristics under the conditions specified in this report.

PREPARED BY : Andrea Hsia , **DATE:** May 27, 2010
Andrea Hsia / Specialist

TECHNICAL ACCEPTANCE : Mason Chang , **DATE:** May 27, 2010
Responsible for RF Mason Chang / Engineer

APPROVED BY : Gary Chang , **DATE:** May 27, 2010
Gary Chang / Assistant Manager



A D T

2. GENERAL INFORMATION

2.1 GENERAL DESCRIPTION OF EUT

EUT	GSM / EGPRS Mobile Phone	
MODEL NO.	EX128 (Refer to Note for the more details)	
FCC ID	IHDP56LJ2	
POWER SUPPLY	3.7Vdc (battery) 5.0Vdc (adapter)	
MODULATION TYPE	GMSK, 8PSK	
FREQUENCY RANGE	824MHz ~ 849MHz ; 1850MHz ~ 1910MHz	
CHANNEL FREQUENCIES UNDER TEST AND ITS CONDUCTED OUTPUT POWER	GSM 850 band	GPRS 850 band
	32.8dBm / 824.2MHz for CH 128 32.8dBm / 836.6MHz for CH190 32.7dBm / 848.8MHz for CH251	32.7dBm / 824.2MHz for CH 128 32.7dBm / 836.6MHz for CH190 32.7dBm / 848.8MHz for CH251
	EGPRS 850 band	PCS1900 band
	26.2dBm / 824.2MHz for CH 128 26.9dBm / 836.6MHz for CH190 26.9dBm / 848.8MHz for CH251	29.5dBm / 1850.2MHz for CH512 29.6dBm / 1880.0MHz for CH661 29.4dBm / 1909.8MHz for CH810
	GPRS 1900 band	EGPRS 1900 band
	29.6dBm / 1850.2MHz for CH512 29.6dBm / 1880.0MHz for CH661 29.4dBm / 1909.8MHz for CH810	25.7dBm / 1850.2MHz for CH512 25.9dBm / 1880.0MHz for CH661 25.9dBm / 1909.8MHz for CH810
MAX. AVERAGE SAR (1g)	HEAD:	0.733W/kg
	BODY:	0.737W/kg
ANTENNA TYPE	Embedded inverted-F	
ANTENNA GAIN	GSM850 BAND: 0.52dBi PCS1900 BAND: 2.4dBi	
ANTENNA CONNECTOR	NA	
DATA CABLE	NA	
I/O PORTS	Refer to user's manual	
ACCESSORY DEVICES	Adapter, Battery, Earphone (Model: YD-16PS-1, 1.3m shielded cable without core)	

NOTE:

- The EUT is a GSM / EGPRS Mobile Phone which has dual SIM card design (Model: EX128) and single SIM card design (Model: EX122).

Brand	Model Name	Remark
MOTOROLA	EX128	dual SIM
MOTOROLA	EX122	single SIM

- The EUT is a Smart Phone. The functions of EUT listed as below:

	REFERENCE REPORT
BLUETOOTH	SA990429C05-1
GSM 850 + PCS 1900	SA990429C05



A D T

3. The communicated functions of EUT listed as below:

		850MHz	1900MHz	With Bluetooth 2.1+EDR function
2G	GSM	√	√	
	GPRS	√	√	
	EGPRS	√	√	

4. The EUT were tested with the following lithium battery and adapter:

Lithium Battery	
BRAND :	MOTOROLA
MODEL :	BQ50
RATING :	3.7V, 910mAh, 3.4Wh

Adapter	
BRAND :	MOTOROLA
MODEL :	DCH3-050US-0303
INPUT :	100-240Vac, 50/60Hz, 0.2A
OUTPUT :	5Vdc, 550mA

- 5. IMEI Code: IMEI (1): 35156604004346-0, IMEI (2): 35156604004712-3.
- 6. Software vision: 7S82070000-002-R1J.
- 7. Hardware vision: EP1.
- 8. The above EUT information was declared by manufacturer and for more detailed features description, please refer to the manufacturer's specifications or User's Manual.

2.2 GENERAL DESCRIPTION OF APPLIED STANDARDS

According to the specifications of the manufacturer, this product must comply with the requirements of the following standards:

FCC Part 2 (2.1093)

FCC OET Bulletin 65, Supplement C (01- 01)

RSS-102

IEEE 1528-2003

All test items have been performed and recorded as per the above standards.

2.3 GENERAL INFORMATION OF THE SAR SYSTEM

DASY4 (**Software 4.7 Build 80**) consists of high precision robot, probe alignment sensor, phantom, robot controller, controlled measurement server and near-field probe. The robot includes six axes that can move to the precision position of the DASY4 software defined. The DASY4 software can define the area that is detected by the probe. The robot is connected to controlled box. Controlled measurement server is connected to the controlled robot box. The DAE includes amplifier, signal multiplexing, AD converter, offset measurement and surface detection. It is connected to the Electro-optical coupler (ECO). The ECO performs the conversion from the optical into digital electric signal of the DAE and transfers data to the PC.

EX3DV4 ISOTROPIC E-FIELD PROBE

CONSTRUCTION	Symmetrical design with triangular core Built-in shielding against static charges PEEK enclosure material (resistant to organic solvents, e.g., DGBE)
FREQUENCY	10 MHz to > 6 GHz Linearity: ± 0.2 dB (30 MHz to 6 GHz)
DIRECTIVITY	± 0.3 dB in HSL (rotation around probe axis) ± 0.5 dB in tissue material (rotation normal to probe axis)
DYNAMIC RANGE	10 μ W/g to > 100 mW/g Linearity: ± 0.2 dB (noise: typically < 1 μ W/g)
DIMENSIONS	Overall length: 330 mm (Tip: 20 mm) Tip diameter: 2.5 mm (Body: 12 mm) Typical distance from probe tip to dipole centers: 1 mm
APPLICATION	High precision dosimetric measurements in any exposure scenario (e.g., very strong gradient fields). Only probe which enables compliance testing for frequencies up to 6 GHz with precision of better 30%.

NOTE

1. The Probe parameters have been calibrated by the SPEAG. Please reference "APPENDIX D" for the Calibration Certification Report.
2. For frequencies above 800MHz, calibration in a rectangular wave-guide is used, because wave-guide size is manageable.
3. For frequencies below 800MHz, temperature transfer calibration is used because the wave-guide size becomes relatively large.



A D T

TWIN SAM V4.0

CONSTRUCTION

The shell corresponds to the specifications of the Specific Anthropomorphic Mannequin (SAM) phantom defined in IEEE 1528-2003, EN 62209-1 and IEC 62209. It enables the dosimetric evaluation of left and right hand phone usage as well as body mounted usage at the flat phantom region. A cover prevents evaporation of the liquid. Reference markings on the phantom allow the complete setup of all predefined phantom positions and measurement grids by manually teaching three points with the robot.

SHELL THICKNESS

2 ± 0.2mm

FILLING VOLUME

Approx. 25liters

DIMENSIONS

Height: 810mm; Length: 1000mm; Width: 500mm

SYSTEM VALIDATION KITS:

CONSTRUCTION

Symmetrical dipole with 1/4 balun enables measurement of feedpoint impedance with NWA matched for use near flat phantoms filled with brain simulating solutions. Includes distance holder and tripod adaptor

CALIBRATION

Calibrated SAR value for specified position and input power at the flat phantom in brain simulating solutions

FREQUENCY

835, 1900MHz

RETURN LOSS

> 20dB at specified validation position

POWER CAPABILITY

> 100W (f < 1GHz); > 40W (f > 1GHz)

OPTIONS

Dipoles for other frequencies or solutions and other calibration conditions upon request



DEVICE HOLDER FOR SAM TWIN PHANTOM

CONSTRUCTION

The device holder for the mobile phone device is designed to cope with different positions given in the standard. It has two scales for the device rotation (with respect to the body axis) and the device inclination (with respect to the line between the ear reference points). The rotation centers for both scales is the ear reference point (ERP). Thus the device needs no repositioning when changing the angles. The holder has been made out of low-loss POM material having the following dielectric parameters: relative permittivity $\varepsilon = 3$ and loss tangent $\delta = 0.02$. The amount of dielectric material has been reduced in the closest vicinity of the device, since measurements have suggested that the influence of the clamp on the test results could thus be lowered. The device holder for the portable device makes up of the polyethylene foam. The dielectric parameters of material close to the dielectric parameters of the air.

DATA ACQUISITION ELECTRONICS

CONSTRUCTION

The data acquisition electronics (DAE3) consists of a highly sensitive electrometer grade preamplifier with auto-zeroing, a channel and gain-switching multiplex, a fast 16 bit AD converter and a command decoder and control logic unit. Transmission to the measurement server is accomplished through an optical downlink for data and status information as well as an optical uplink for commands and the clock. The mechanical probe is mounting device includes two different sensor systems for frontal and sideways probe contacts. They are used for mechanical surface detection and probe collision detection. The input impedance of the DAE3 box is 200M Ω ; the inputs are symmetrical and floating. Common mode rejection is above 80 dB.



A D T

2.4 TEST EQUIPMENT

FOR SAR MEASUREMENT

ITEM	NAME	BRAND	TYPE	SERIES NO.	DATE OF CALIBRATION	DUE DATE OF CALIBRATION
1	SAM Phantom	S & P	QD000 P40 CA	TP-1202	NA	NA
2	Signal Generator	Agilent	E8257C	MY43320668	Feb. 23, 2010	Feb. 22, 2011
3	E-Field Probe	S & P	EX3DV4	3590	Mar. 25, 2010	Mar. 24, 2011
4	DAE	S & P	DAE	861	Jan. 22, 2010	Jan. 21, 2011
5	Robot Positioner	Staubli Unimation	NA	NA	NA	NA
6	Validation Dipole	S & P	D835V2	4d021	May. 25, 2009	May. 24, 2010
7	Validation Dipole	S & P	D1900V2	5d036	Feb. 23, 2010	Feb. 22, 2011

NOTE: Before starting, all test equipment shall be warmed up for 30min.

FOR TISSUE PROPERTY

ITEM	NAME	BRAND	TYPE	SERIES NO.	DATE OF CALIBRATION	DUE DATE OF CALIBRATION
1	Network Analyzer	Agilent	E8358A	US41480538	Dec. 03, 2009	Dec. 02, 2010
2	Dielectric Probe	Agilent	85070D	US01440176	NA	NA

NOTE:

1. Before starting, all test equipment shall be warmed up for 30min.
2. The tolerance ($k=1$) specified by Agilent for general dielectric measurements, deriving from inaccuracies in the calibration data, analyzer drift, and random errors, are usually $\pm 2.5\%$ and $\pm 5\%$ for measured permittivity and conductivity, respectively. However, the tolerances for the conductivity is smaller for material with large loss tangents, i.e., less than $\pm 2.5\%$ ($k=1$). It can be substantially smaller if more accurate methods are applied



2.5 GENERAL DESCRIPTION OF THE SPATIAL PEAK SAR EVALUATION

The DASY4 post-processing software (SEMCAD) automatically executes the following procedures to calculate the field units from the micro-volt readings at the probe connector. The parameters used in the evaluation are stored in the configuration modules of the software:

Probe parameters:	- Sensitivity	Norm _i , a _{i0} , a _{i1} , a _{i2}
	- Conversion factor	ConvF _i
	- Diode compression point	dcp _i
Device parameters:	- Frequency	F
	- Crest factor	Cf
Media parameters:	- Conductivity	σ
	- Density	ρ

The first step of the evaluation is a linearization of the filtered input signal to account for the compression characteristics of the detector diode. The compensation depends on the input signal, the diode type and the DC-transmission factor from the diode to the evaluation electronics. If the exciting field is pulsed, the crest factor of the signal must be known to correctly compensate for peak power. The formula for each channel can be given as:

$$V_i = U_i + U_i^2 \cdot \frac{cf}{dcp_i}$$

V _i	=compensated signal of channel i	(i = x, y, z)
U _i	=input signal of channel i	(i = x, y, z)
Cf	=crest factor of exciting field	(DASY parameter)
dcp _i	=diode compression point	(DASY parameter)

From the compensated input signals the primary field data for each channel can be evaluated:

$$\text{E-field probes: } E_i = \sqrt{\frac{V_i}{\text{Norm}_i \cdot \text{ConvF}}}$$

$$\text{H-field probes: } H_i = \sqrt{V_i} \cdot \frac{a_{i0} + a_{i1}f + a_{i2}f^2}{f}$$

- V_i = compensated signal of channel I (i = x, y, z)
- Norm_i = sensor sensitivity of channel i $\mu\text{V}/(\text{V/m})^2$ for E-field Probes (i = x, y, z)
- ConvF = sensitivity enhancement in solution
- a_{ij} = sensor sensitivity factors for H-field probes
- f = carrier frequency [GHz]
- E_i = electric field strength of channel i in V/m
- H_i = magnetic field strength of channel i in A/m

The RSS value of the field components gives the total field strength (Hermitian magnitude):

$$E_{tot} = \sqrt{E_x^2 + E_y^2 + E_z^2}$$

The primary field data are used to calculate the derived field units.

$$SAR = E_{tot}^2 \cdot \frac{\sigma}{\rho \cdot 1'000}$$

- SAR = local specific absorption rate in mW/g
- E_{tot} = total field strength in V/m
- σ = conductivity in [mho/m] or [Siemens/m]
- ρ = equivalent tissue density in g/cm³



A D T

Note that the density is set to 1, to account for actual head tissue density rather than the density of the tissue simulating liquid. The entire evaluation of the spatial peak values is performed within the Post-processing engine (SEMCAD). The system always gives the maximum values for the 1g and 10g cubes. The algorithm to find the cube with highest averaged SAR is divided into the following stages:

1. The extraction of the measured data (grid and values) from the Zoom Scan
2. The calculation of the SAR value at every measurement point based on all stored data (A/D values and measurement parameters)
3. The generation of a high-resolution mesh within the measured volume
4. The interpolation of all measured values from the measurement grid to the high-resolution grid
5. The extrapolation of the entire 3-D field distribution to the phantom surface over the distance from sensor to surface
6. The calculation of the averaged SAR within masses of 1g and 10g.

The probe is calibrated at the center of the dipole sensors that is located 1 to 2.7mm away from the probe tip. During measurements, the probe stops shortly above the phantom surface, depending on the probe and the surface detecting system. Both distances are included as parameters in the probe configuration file. The software always knows exactly how far away the measured point is from the surface. As the probe cannot directly measure at the surface, the values between the deepest measured point and the surface must be extrapolated. The angle between the probe axis and the surface normal line is less than 30 degree.



The maximum search is automatically performed after each area scan measurement. It is based on splines in two or three dimensions. The procedure can find the maximum for most SAR distributions even with relatively large grid spacing. After the area scanning measurement, the probe is automatically moved to a position at the interpolated maximum. The following scan can directly use this position for reference, e.g., for a finer resolution grid or the cube evaluations. The 1g and 10g peak evaluations are only available for the predefined cube 7 x 7 x 7 scans. The routines are verified and optimized for the grid dimensions used in these cube measurements. The measured volume of 30 x 30 x 30mm contains about 30g of tissue. The first procedure is an extrapolation (incl. boundary correction) to get the points between the lowest measured plane and the surface. The next step uses 3D interpolation to get all points within the measured volume in a 1mm grid (42875 points). In the last step, a 1g cube is placed numerically into the volume and its averaged SAR is calculated. This cube is the moved around until the highest averaged SAR is found. If the highest SAR is found at the edge of the measured volume, the system will issue a warning: higher SAR values might be found outside of the measured volume. In that case the cube measurement can be repeated, using the new interpolated maximum as the center.

3. DESCRIPTION OF SUPPORT UNITS

NO.	PRODUCT	BRAND	MODEL NO.	SERIAL NO.
1	Universal Radio Communication Tester	R&S	CMU200	104484

NO.	SIGNAL CABLE DESCRIPTION OF THE ABOVE SUPPORT UNITS
1	NA

NOTE: All power cords of the above support units are non shielded (1.8m).



4. RECIPES FOR TISSUE SIMULATING LIQUIDS

For the measurement of the field distribution inside the SAM phantom, the phantom must be filled with 25 liters of tissue simulation liquid.

The following are some common ingredients :

- **WATER-** Deionized water (pure H₂O), resistivity ≈ 16 M - as basis for the liquid
- **SUGAR-** Refined sugar in crystals, as available in food shops - to reduce relative permittivity
- **SALT-** Pure NaCl - to increase conductivity
- **CELLULOSE-** Hydroxyethyl-cellulose, medium viscosity (75-125mPa.s, 2% in water, 20_C),
CAS # 54290 - to increase viscosity and to keep sugar in solution
- **PRESERVATIVE-** Preventol D-7 Bayer AG, D-51368 Leverkusen, CAS # 55965-84-9 - to prevent the spread of bacteria and molds
- **DGMBE-** Diethylenglycol-monobuthyl ether (DGMBE), Fluka Chemie GmbH, CAS # 112-34-5 - to reduce relative permittivity

THE RECIPES FOR 835MHz SIMULATING LIQUID TABLE

INGREDIENT	HEAD SIMULATING LIQUID 835MHz (HSL-835)	MUSCLE SIMULATING LIQUID 835MHz (MSL-835)
Water	40.28%	50.07%
Cellulose	02.41%	NA
Salt	01.38%	0.94%
Preventtol D-7	00.18%	0.09%
Sugar	57.97%	48.2%
Dielectric Parameters at 22°C	f = 835MHz $\epsilon = 41.5 \pm 5\%$ $\sigma = 0.97 \pm 5\%$ S/m	f = 835MHz $\epsilon = 55.0 \pm 5\%$ $\sigma = 1.05 \pm 5\%$ S/m



A D T

THE RECIPES FOR 1900MHz SIMULATING LIQUID TABLE

INGREDIENT	HEAD SIMULATING LIQUID 1900MHz (HSL-1900)	MUSCLE SIMULATING LIQUID 1900MHz (MSL-1900)
Water	55.24%	70.16%
DGMBE	44.45%	29.44%
Salt	0.306%	00.39%
Dielectric Parameters at 22°C	f= 1900MHz $\epsilon = 40.0 \pm 5\%$ $\sigma = 1.40 \pm 5\%$ S/m	f= 1900MHz $\epsilon = 53.3 \pm 5\%$ $\sigma = 1.52 \pm 5\%$ S/m

Testing the liquids using the Agilent Network Analyzer E8358A and Agilent Dielectric Probe Kit 85070D. The testing procedure is following as

1. Turn Network Analyzer on and allow at least 30min. warm up.
2. Mount dielectric probe kit so that interconnecting cable to Network Analyzer will not be moved during measurements or calibration.
3. Pour de-ionized water and measure water temperature ($\pm 1^\circ$).
4. Set water temperature in Agilent-Software (Calibration Setup).
5. Perform calibration.
6. Validate calibration with dielectric material of known properties (e.g. polished ceramic slab with $>8\text{mm}$ thickness $\epsilon' = 10.0$, $\epsilon'' = 0.0$). If measured parameters do not fit within tolerance, repeat calibration (± 0.2 for ϵ' : ± 0.1 for ϵ'').
7. Conductivity can be calculated from ϵ'' by $\sigma = \omega \epsilon_0 \epsilon'' = \epsilon'' f [\text{GHz}] / 18$.
8. Measure liquid shortly after calibration. Repeat calibration every hour.
9. Stir the liquid to be measured. Take a sample ($\sim 50\text{ml}$) with a syringe from the center of the liquid container.
10. Pour the liquid into a small glass flask. Hold the syringe at the bottom of the flask to avoid air bubbles.
11. Put the dielectric probe in the glass flask. Check that there are no air bubbles in front of the opening in the dielectric probe kit.
12. Perform measurements.
13. Adjust medium parameters in DASY4 for the frequencies necessary for the measurements ('Setup Config', select medium (e.g. Brain 900MHz) and press 'Option'-button).
14. Select the current medium for the frequency of the validation (e.g. Setup Medium Brain 900MHz).



FOR GSM850 BAND SIMULATING LIQUID

LIQUID TYPE		HSL-835			
SIMULATING LIQUID TEMP.		22.7			
TEST DATE		May 11, 2010			
TESTED BY		Aaron Liang			
FREQ. (MHz)	LIQUID PARAMETER	STANDARD VALUE	MEASUREMENT VALUE	ERROR PERCENTAGE (%)	LIMIT(%)
835.0	Permittivity (ϵ)	41.50	42.30	1.93	±5
836.6		41.50	42.10	1.45	
835.0	Conductivity (σ) S/m	0.90	0.91	1.11	
836.6		0.90	0.92	2.22	

LIQUID TYPE		MSL-835			
SIMULATING LIQUID TEMP.		22.8			
TEST DATE		May 13, 2010			
TESTED BY		Aaron Liang			
FREQ. (MHz)	LIQUID PARAMETER	STANDARD VALUE	MEASUREMENT VALUE	ERROR PERCENTAGE (%)	LIMIT(%)
835.0	Permittivity (ϵ)	55.20	53.50	-3.08	±5
836.6		55.20	53.40	-3.26	
835.0	Conductivity (σ) S/m	0.97	0.95	-2.06	
836.6		0.97	0.96	-1.03	



A D T

LIQUID TYPE		HSL-835			
SIMULATING LIQUID TEMP.		22.7			
TEST DATE		May 24, 2010			
TESTED BY		Sam Onn			
FREQ. (MHz)	LIQUID PARAMETER	STANDARD VALUE	MEASUREMENT VALUE	ERROR PERCENTAGE (%)	LIMIT(%)
835.0	Permittivity (ϵ)	41.50	42.20	1.69	±5
836.6		41.50	42.10	1.45	
835.0	Conductivity (σ) S/m	0.90	0.92	2.22	
836.6		0.90	0.92	2.22	

LIQUID TYPE		MSL-835			
SIMULATING LIQUID TEMP.		22.8			
TEST DATE		May 24, 2010			
TESTED BY		Sam Onn			
FREQ. (MHz)	LIQUID PARAMETER	STANDARD VALUE	MEASUREMENT VALUE	ERROR PERCENTAGE (%)	LIMIT(%)
835.0	Permittivity (ϵ)	55.20	53.50	-3.08	±5
836.6		55.20	53.40	-3.26	
835.0	Conductivity (σ) S/m	0.97	0.94	-3.09	
836.6		0.97	0.95	-2.06	



A D T

FOR BAND SIMULATING LIQUID

LIQUID TYPE		HSL-1900			
SIMULATING LIQUID TEMP.		22.5			
TEST DATE		May 12, 2010			
TESTED BY		Aaron Liang			
FREQ. (MHz)	LIQUID PARAMETER	STANDARD VALUE	MEASUREMENT VALUE	ERROR PERCENTAGE (%)	LIMIT(%)
1880	Permittivity (ϵ)	40.00	40.37	0.92	±5
1900		40.00	40.33	0.82	
1880	Conductivity (σ) S/m	1.40	1.42	1.43	
1900		1.40	1.45	3.57	

LIQUID TYPE		MSL-1900			
SIMULATING LIQUID TEMP.		22.6			
TEST DATE		May 14, 2010			
TESTED BY		Aaron Liang			
FREQ. (MHz)	LIQUID PARAMETER	STANDARD VALUE	MEASUREMENT VALUE	ERROR PERCENTAGE (%)	LIMIT(%)
1880	Permittivity (ϵ)	53.30	52.30	-1.88	±5
1900		53.30	51.80	-2.81	
1880	Conductivity (σ) S/m	1.52	1.55	1.97	
1900		1.52	1.57	3.29	



A D T

LIQUID TYPE		HSL-1900			
SIMULATING LIQUID TEMP.		22.5			
TEST DATE		May 25, 2010			
TESTED BY		Aaron Liang			
FREQ. (MHz)	LIQUID PARAMETER	STANDARD VALUE	MEASUREMENT VALUE	ERROR PERCENTAGE (%)	LIMIT(%)
1880	Permittivity (ϵ)	40.00	40.50	1.25	±5
1900		40.00	40.40	1.00	
1880	Conductivity (σ) S/m	1.40	1.39	-0.71	
1900		1.40	1.39	-0.71	

LIQUID TYPE		MSL-1900			
SIMULATING LIQUID TEMP.		22.6			
TEST DATE		May 25, 2010			
TESTED BY		Aaron Liang			
FREQ. (MHz)	LIQUID PARAMETER	STANDARD VALUE	MEASUREMENT VALUE	ERROR PERCENTAGE (%)	LIMIT(%)
1880	Permittivity (ϵ)	53.30	54.60	2.44	±5
1900		53.30	54.50	2.25	
1880	Conductivity (σ) S/m	1.52	1.53	0.66	
1900		1.52	1.54	1.32	

5. SYSTEM VALIDATION

The system validation was performed in the flat phantom with equipment listed in the following table. Since the SAR value is calculated from the measured electric field, dielectric constant and conductivity of the body tissue and the SAR is proportional to the square of the electric field. So, the SAR value will be also proportional to the RF power input to the system validation dipole under the same test environment. In our system validation test, 250mW RF input power was used.

5.1 TEST PROCEDURE

Before the system performance check, we need only to tell the system which components (probe, medium, and device) are used for the system performance check; the system will take care of all parameters. The dipole must be placed beneath the flat section of the SAM Twin Phantom with the correct distance holder in place. The distance holder should touch the phantom surface with a light pressure at the reference marking (little cross) and be oriented parallel to the long side of the phantom. Accurate positioning is not necessary, since the system will search for the peak SAR location, except that the dipole arms should be parallel to the surface. The device holder for mobile phones can be left in place but should be rotated away from the dipole.

1. The "Power Reference Measurement" and "Power Drift Measurement" jobs are located at the beginning and end of the batch process. They measure the field drift at one single point in the liquid over the complete procedure. The indicated drift is mainly the variation of the amplifier output power. If it is too high (above ± 0.1 dB), the system performance check should be repeated; some amplifiers have very high drift during warm-up. A stable amplifier gives drift results in the DASY system below ± 0.02 dB.
2. The "Surface Check" job tests the optical surface detection system of the DASY system by repeatedly detecting the surface with the optical and mechanical surface detector and comparing the results. The output gives the detecting heights of both systems, the difference between the two systems and the standard deviation of the detection repeatability. Air bubbles or refraction in the liquid due to separation of the sugar-water mixture gives poor repeatability (above ± 0.1 mm). In that case it is better to abort the system performance check and stir the liquid.

3. The "Area Scan" job measures the SAR above the dipole on a plane parallel to the surface. It is used to locate the approximate location of the peak SAR. The proposed scan uses large grid spacing for faster measurement; due to the symmetric field, the peak detection is reliable. If a finer graphic is desired, the grid spacing can be reduced. Grid spacing and orientation have no influence on the SAR result.
4. The "Zoom Scan" job measures the field in a volume around the peak SAR value assessed in the previous "Area Scan" job (for more information see the application note on SAR evaluation).

About the validation dipole positioning uncertainty, the constant and low loss dielectric spacer is used to establish the correct distance between the top surface of the dipole and the bottom surface of the phantom, the error component introduced by the uncertainty of the distance between the liquid (i.e., phantom shell) and the validation dipole in the DASY4 system is less than $\pm 0.1\text{mm}$.

$$SAR_{tolerance} [\%] = 100 \times \left(\frac{(a + d)^2}{a^2} - 1 \right)$$

As the closest distance is 10mm, the resulting tolerance $SAR_{tolerance}[\%]$ is <2%.



5.2 V ALIDATION RESULTS

SYSTEM VALIDATION TEST OF SIMULATING LIQUID					
FREQUENCY (MHz)	REQUIRED SAR (mW/g)	MEASURED SAR (mW/g)	DEVIATION (%)	SEPARATION DISTANCE	TESTED DATE
HSL835	2.37 (1g)	2.43	2.53	15mm	May 11, 2010
MSL835	2.54 (1g)	2.66	4.72	15mm	May 13, 2010
HSL1900	10.00 (1g)	10.40	4.00	10mm	May 12, 2010
MSL1900	10.30 (1g)	10.50	1.94	10mm	May 14, 2010
TESTED BY	Aaron Liang.				
HSL835	2.37 (1g)	2.34	-1.27	15mm	May 24, 2010
MSL835	2.54 (1g)	2.43	-4.33	15mm	May 24, 2010
HSL1900	10.00 (1g)	10.50	5.00	10mm	May 25, 2010
MSL1900	10.30 (1g)	9.68	-6.02	10mm	May 25, 2010
TESTED BY	Sam Onn				

NOTE: Please see Appendix for the photo of system validation test.



5.3 SYSTEM VALIDATION UNCERTAINTIES

In the table below, the system validation uncertainty with respect to the analytically assessed SAR value of a dipole source as given in the IEEE 1528 standard is given. This uncertainty is smaller than the expected uncertainty for mobile phone measurements due to the simplified setup and the symmetric field distribution.

Error Description	Tolerance (±%)	Probability Distribution	Divisor	(C _i)		Standard Uncertainty (±%)		(v _i)
				(1g)	(10g)	(1g)	(10g)	
Measurement System								
Probe Calibration	5.50	Normal	1	1	1	5.50	5.50	∞
Axial Isotropy	0.50	Rectangular	√3	0.7	0.7	0.20	0.20	∞
Hemispherical Isotropy	2.60	Rectangular	√3	0.7	0.7	1.05	1.05	∞
Boundary effects	1.00	Rectangular	√3	1	1	0.58	0.58	∞
Linearity	0.60	Rectangular	√3	1	1	0.35	0.35	∞
System Detection Limits	1.00	Rectangular	√3	1	1	0.58	0.58	∞
Readout Electronics	0.30	Normal	1	1	1	0.30	0.30	∞
Response Time	0.80	Rectangular	√3	1	1	0.46	0.46	∞
Integration Time	2.60	Rectangular	√3	1	1	1.50	1.50	∞
RF Ambient Noise	3.00	Rectangular	√3	1	1	1.73	1.73	∞
RF Ambient Reflections	3.00	Rectangular	√3	1	1	1.73	1.73	∞
Probe Positioner	0.40	Rectangular	√3	1	1	0.23	0.23	∞
Probe Positioning	2.90	Rectangular	√3	1	1	1.67	1.67	∞
Max. SAR Eval.	1.00	Rectangular	√3	1	1	0.58	0.58	∞
Dipole Related								
Dipole Axis to Liquid Distance	2.00	Rectangular	√3	1	1	1.15	1.15	145
Input Power Drift	5.00	Rectangular	√3	1	1	2.89	2.89	∞
Phantom and Tissue parameters								
Phantom Uncertainty	4.00	Rectangular	√3	1	1	2.31	2.31	∞
Liquid Conductivity (target)	5.00	Rectangular	√3	0.64	0.43	1.85	1.24	∞
Liquid Conductivity (measurement)	4.10	Normal	1	0.64	0.43	2.62	1.76	∞
Liquid Permittivity (target)	5.00	Rectangular	√3	0.6	0.49	1.73	1.41	∞
Liquid Permittivity (measurement)	3.84	Normal	1	0.6	0.49	2.30	1.88	∞
Combined Standard Uncertainty						8.81	8.31	
Coverage Factor for 95%						Kp=2		
Expanded Uncertainty (K=2)						17.61	16.63	

NOTE: About the system validation uncertainty assessment, please reference the section 7.

6. TEST RESULTS

6.1 TEST PROCEDURES

The EUT makes a phone call to the communication simulator station. Establish the simulation communication configuration rather the actual communication. Then the EUT could continuous the transmission mode. Adjust the PCL of the base station could controlled the EUT to transmitted the maximum output power. The base station also could control the transmission channel. The SAR value was calculated via the 3D spline interpolation algorithm that has been implemented in the software of DASY4 SAR measurement system manufactured and calibrated by SPEAG. According to the IEEE 1528 / EN 62209-1, the recommended procedure for assessing the peak spatial-average SAR value consists of the following steps:

- Power reference measurement
- Verification of the power reference measurement
- Area scan
- Zoom scan
- Power reference measurement

The area scan was performed for the highest spatial SAR location. The zoom scan with 30mm x 30mm x 30mm volume was performed for SAR value averaged over 1g and 10g spatial volumes.

In the zoom scan, the distance between the measurement point at the probe sensor location (geometric center behind the probe tip) and the phantom surface is 3mm and maintained at a constant distance of ± 0.5 mm during a zoom scan to determine peak SAR locations. The distance is 3mm between the first measurement point and the bottom surface of the phantom. The secondary measurement point to the bottom surface of the phantom is with 8mm separation distance. The cube size is 7 x 7 x 7 points consists of 343 points and the grid space is 5mm.



The measurement time is 0.5s at each point of the zoom scan. The probe boundary effect compensation shall be applied during the SAR test. Because of the tip of the probe to the Phantom surface separated distances are longer than half a tip probe diameter.

In the area scan, the separation distance is 3mm between the each measurement point and the phantom surface. The scan size shall be included the transmission portion of the EUT. The measurement time is the same as the zoom scan. At last the reference power drift shall be less than $\pm 5\%$.

6.2 DESCRIPTION OF TEST CONDITION

TEST DATE	TISSUE TYPE / FREQ.	TEST MODE	TEMPERATURE (°C)		HUMIDITY (%RH)	TESTED BY
			AIRBENT	LIQUID		
FOR MODEL: EX128						
May 11, 2010	HSL835	1 ~ 4 & 29	23.0	22.7	61	Aaron Liang
May 13, 2010	MSL835	9 ~ 18 & 31	23.0	22.8	61	Aaron Liang
May 12, 2010	HSL1900	5 ~ 8 & 30	23.0	22.5	61	Aaron Liang
May 14, 2010	MSL1900	19 ~ 28 & 32	22.9	22.6	62	Aaron Liang
FOR MODEL: EX122						
May 24, 2010	HSL835	1	23.0	22.7	61	Sam Onn
May 24, 2010	MSL835	3	23.0	22.8	61	Sam Onn
May 25, 2010	HSL1900	2	23.0	22.5	61	Sam Onn
May 25, 2010	MSL1900	4	22.9	22.6	62	Sam Onn



6.3 MEASURED SAR RESULT

FOR MODEL EX128

The EUT supports 2 SIM cards function, but only one SIM card function can active at a time. After pretest of SIM 1 and SIM2, find the SAR value of SM 1 is higher than SIM2. Therefore, select SIM1 to do final test and SIM 2 test the worst channel of SIM1

SAR (1g)-SIM 1				
HEAD	RIGHT		LEFT	
	CHEEK	TILT	CHEEK	TILT
GSM 850				
Middle	0.576	0.264	0.637	0.277
PCS 1900				
Middle	0.603	0.225	0.733	0.206

SAR (1g)-SIM-1		
BODY	Front	Bottom
GSM 850		
Middle	0.321	0.402
GPRS 850 TS1		
Middle	0.256	0.380
GPRS 850 TS2		
Middle	0.533	0.737
EGPRS 850 TS1		
Middle	0.126	0.160
EGPRS 850 TS2		
Middle	0.316	0.473
PCS 1900		
Middle	0.143	0.191
GPRS 1900 TS1		
Middle	0.131	0.175
GPRS 1900 TS2		
Middle	0.222	0.296
EGPRS 1900 TS1		
Middle	0.068	0.094
EGPRS 1900 TS2		
Middle	0.134	0.180



SAR (1g)-SIM 2				
HEAD	RIGHT		LEFT	
	CHEEK	TILT	CHEEK	TILT
GSM 850				
Middle	/	/	0.623	/
PCS 1900				
Middle	/	/	0.718	/

SAR (1g)-SIM-2		
BODY	Front	Bottom
GPRS 850 TS2		
Middle	/	0.722
GPRS 1900 TS2		
Middle	/	0.292

NOTE:

1. In this testing, the limit for General Population Spatial Peak averaged over 1g, 1.6 W/kg, is applied.
2. Please see the Appendix A for the data.
3. The variation of the EUT conducted power measured before and after SAR testing should not over 5%.
4. Per DA-02-1438A1, when 1-g SAR for the middle channel is less than 0.8 W/kg, testing for the other channels is not required

FOR MODEL EX122

Difference between EX 128 and EX 122 is only the components of SIM portion. The other part is identical to each other. After pretest of EX128 and EX 122, find SAR of EX 128 is higher than 122. Therefore, select EX128 to do final test and EX 122 tested the worst channel of EX 128.

SAR (1g)-SIM 1				
HEAD	RIGHT		LEFT	
	CHEEK	TILT	CHEEK	TILT
GSM 850				
Middle	/	/	0.629	/
PCS 1900				
Middle	/	/	0.714	/

SAR (1g)-SIM-1		
BODY	Front	Bottom
GPRS 850 TS2		
Middle	/	0.725
GPRS 1900 TS2		
Middle	/	0.283

NOTE:

1. In this testing, the limit for General Population Spatial Peak averaged over 1g, 1.6 W/kg, is applied.
2. Please see the Appendix A for the data.
3. The variation of the EUT conducted power measured before and after SAR testing should not over 5%.
4. Per DA-02-1438A1, when 1-g SAR for the middle channel is less than 0.8 W/kg, testing for the other channels is not required



6.4 SAR LIMITS

HUMAN EXPOSURE	SAR (W/kg)	
	(GENERAL POPULATION / UNCONTROLLED EXPOSURE ENVIRONMENT)	(OCCUPATIONAL / CONTROLLED EXPOSURE ENVIRONMENT)
Spatial Peak (averaged over 1 g)	1.6	8.0

NOTE:

1. This limits accord to 47 CFR 2.1093 – Safety Limit.
2. The EUT property been complied with the partial body exposure limit under the general population environment.



7. INFORMATION ON THE TESTING LABORATORIES

We, Bureau Veritas Consumer Products Services (H.K.) Ltd., Taoyuan Branch, were founded in 1988 to provide our best service in EMC, Radio, Telecom and Safety consultation. Our laboratories are accredited and approved according to ISO/IEC 17025.

Copies of accreditation certificates of our laboratories obtained from approval agencies can be downloaded from our web site: www.adt.com.tw/index.5/phtml. If you have any comments, please feel free to contact us at the following:

Linko EMC/RF Lab:

Tel: 886-2-26052180

Fax: 886-2-26051924

Hsin Chu EMC/RF Lab:

Tel: 886-3-5935343

Fax: 886-3-5935342

Hwa Ya EMC/RF/Safety/Telecom Lab:

Tel: 886-3-3183232

Fax: 886-3-3185050

Web Site: www.adt.com.tw

The address and road map of all our labs can be found in our web site also.

---END---

APPENDIX A: TEST DATA

Liquid Level Photo

HSL 835MHz D=151mm



HSL 1900MHz D=151mm



MSL 835MHz D=152mm



MSL 1900MHz D=151mm



Test Laboratory: Bureau Veritas ADT

M01-Right Head Cheek- GSM 850-Ch190

DUT: GSM/EGPRS Mobile Phone ; Type: EX128

Communication System: GSM 850 ; Frequency: 836.6 MHz ; Duty Cycle: 1:8.3

Medium: HSL835 Medium parameters used: $f = 836.6$ MHz; $\sigma = 0.92$ mho/m; $\epsilon_r = 42.1$; $\rho = 1000$ kg/m³

Phantom section: Right Section ; DUT test position : Cheek ; Modulation type: GMSK

DASY4 Configuration:

- Probe: EX3DV4 - SN3590 ; ConvF(10.25, 10.25, 10.25) ; Calibrated: 2010/3/25
- Sensor-Surface: 3mm (Mechanical Surface Detection)
- Electronics: DAE4 Sn861; Calibrated: 2010/1/22
- Phantom: SAM 12; Type: SAM V4.0; Serial: TP 1202
- Measurement SW: DASY4, V4.7 Build 80; Postprocessing SW: SEMCAD, V1.8 Build 186

Mid Channel 190 /Area Scan (7x11x1): Measurement grid: dx=15mm, dy=15mm

Maximum value of SAR (measured) = 0.614 mW/g

Mid Channel 190 /Zoom Scan (7x7x9)/Cube 0: Measurement grid: dx=5mm, dy=5mm, dz=3mm

Reference Value = 8.56 V/m; Power Drift = -0.046 dB

Peak SAR (extrapolated) = 0.756 W/kg

SAR(1 g) = **0.576 mW/g**; SAR(10 g) = **0.408 mW/g**

Maximum value of SAR (measured) = 0.642 mW/g

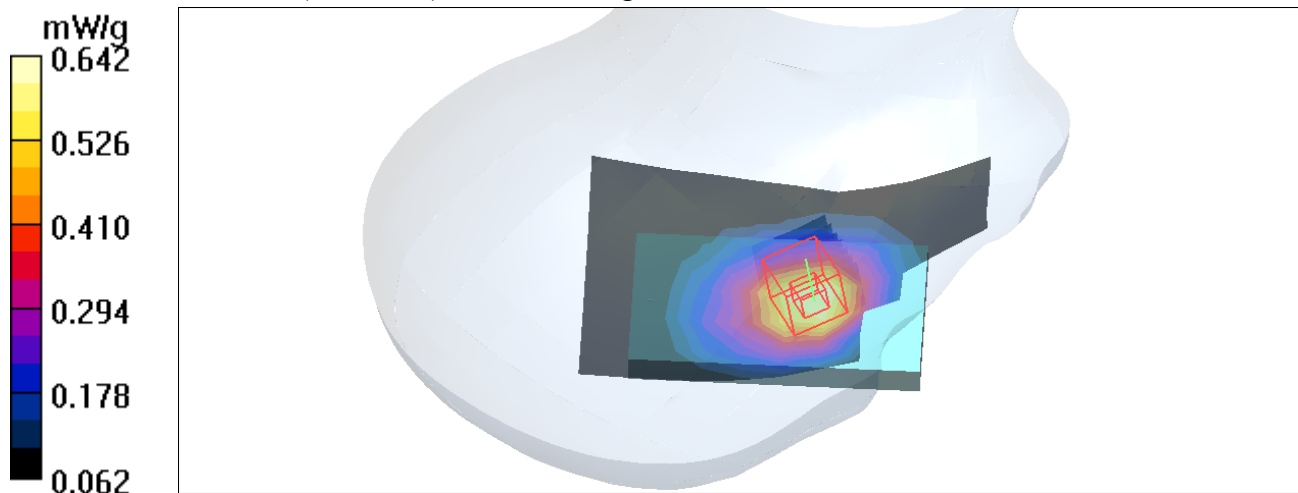

Test Laboratory: Bureau Veritas ADT

M02-Right Head Tilt- GSM 850-Ch190

DUT: GSM/EGPRS Mobile Phone ; Type: EX128

Communication System: GSM 850 ; Frequency: 836.6 MHz ; Duty Cycle: 1:8.3

Medium: HSL835 Medium parameters used: $f = 836.6$ MHz; $\sigma = 0.92$ mho/m; $\epsilon_r = 42.1$; $\rho = 1000$ kg/m³

Phantom section: Right Section ; DUT test position : Tilt ; Modulation type: GMSK

DASY4 Configuration:

- Probe: EX3DV4 - SN3590 ; ConvF(10.25, 10.25, 10.25) ; Calibrated: 2010/3/25
- Sensor-Surface: 3mm (Mechanical Surface Detection)
- Electronics: DAE4 Sn861; Calibrated: 2010/1/22
- Phantom: SAM 12; Type: SAM V4.0; Serial: TP 1202
- Measurement SW: DASY4, V4.7 Build 80; Postprocessing SW: SEMCAD, V1.8 Build 186

Mid Channel 190 /Area Scan (7x11x1): Measurement grid: dx=15mm, dy=15mm

Maximum value of SAR (measured) = 0.289 mW/g

Mid Channel 190 /Zoom Scan (7x7x9)/Cube 0: Measurement grid: dx=5mm, dy=5mm, dz=3mm

Reference Value = 12.4 V/m; Power Drift = -0.034 dB

Peak SAR (extrapolated) = 0.338 W/kg

SAR(1 g) = **0.264** mW/g; SAR(10 g) = **0.198** mW/g

Maximum value of SAR (measured) = 0.290 mW/g

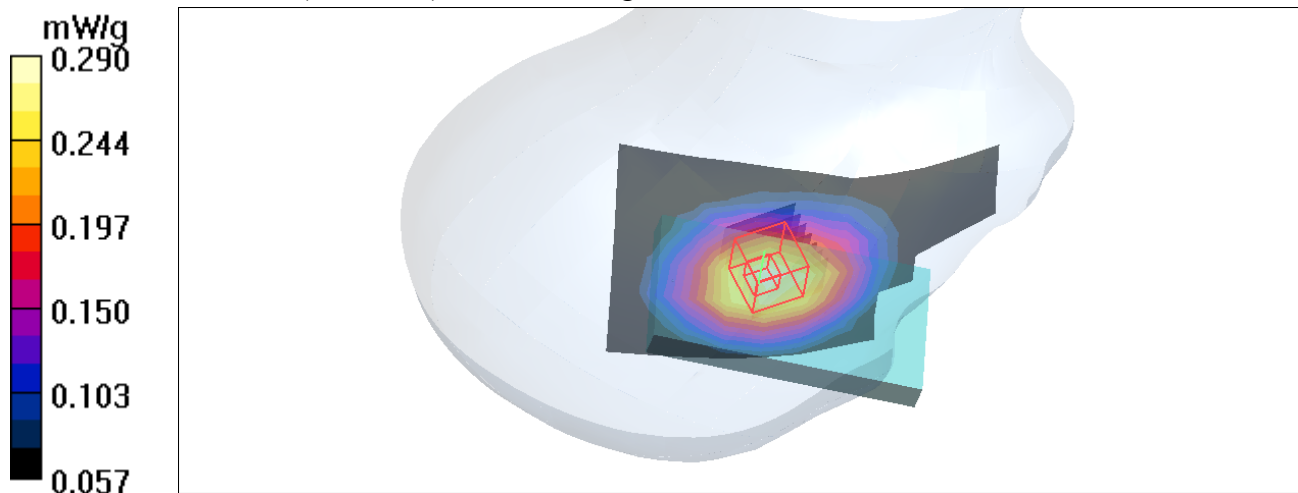

Test Laboratory: Bureau Veritas ADT

M03-Left Head Cheek- GSM 850-Ch190**DUT: GSM/EGPRS Mobile Phone ; Type: EX128**

Communication System: GSM 850 ; Frequency: 836.6 MHz ; Duty Cycle: 1:8.3

Medium: HSL835 Medium parameters used: $f = 836.6$ MHz; $\sigma = 0.92$ mho/m; $\epsilon_r = 42.1$; $\rho = 1000$ kg/m³

Phantom section: Left Section ; DUT test position : Cheek ; Modulation type: GMSK

DASY4 Configuration:

- Probe: EX3DV4 - SN3590 ; ConvF(10.25, 10.25, 10.25) ; Calibrated: 2010/3/25
- Sensor-Surface: 3mm (Mechanical Surface Detection)
- Electronics: DAE4 Sn861; Calibrated: 2010/1/22
- Phantom: SAM 12; Type: SAM V4.0; Serial: TP 1202
- Measurement SW: DASY4, V4.7 Build 80; Postprocessing SW: SEMCAD, V1.8 Build 186

Mid Channel 190 /Area Scan (7x11x1): Measurement grid: dx=15mm, dy=15mm

Maximum value of SAR (measured) = 0.746 mW/g

Mid Channel 190 /Zoom Scan (7x7x9)/Cube 0: Measurement grid: dx=5mm, dy=5mm, dz=3mm

Reference Value = 8.25 V/m; Power Drift = 0.064 dB

Peak SAR (extrapolated) = 1.00 W/kg

SAR(1 g) = **0.637** mW/g; SAR(10 g) = **0.427** mW/g

Maximum value of SAR (measured) = 0.745 mW/g

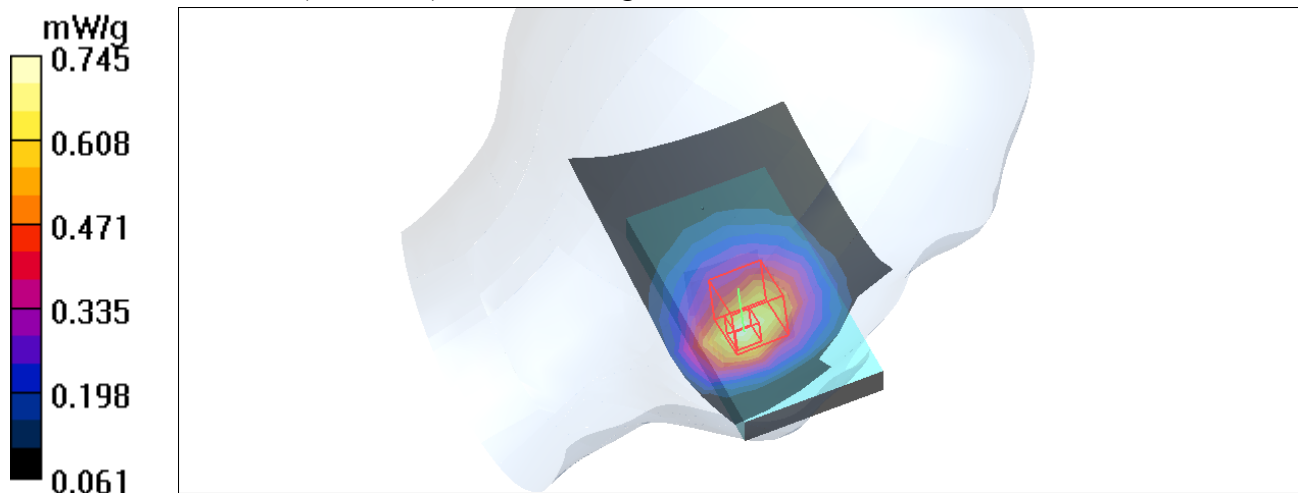

Test Laboratory: Bureau Veritas ADT

M04-Left Head Tilt- GSM 850-Ch190

DUT: GSM/EGPRS Mobile Phone ; Type: EX128

Communication System: GSM 850 ; Frequency: 836.6 MHz ; Duty Cycle: 1:8.3

Medium: HSL835 Medium parameters used: $f = 836.6$ MHz; $\sigma = 0.92$ mho/m; $\epsilon_r = 42.1$; $\rho = 1000$ kg/m³

Phantom section: Left Section ; DUT test position : Tilt ; Modulation type: GMSK

DASY4 Configuration:

- Probe: EX3DV4 - SN3590 ; ConvF(10.25, 10.25, 10.25) ; Calibrated: 2010/3/25
- Sensor-Surface: 3mm (Mechanical Surface Detection)
- Electronics: DAE4 Sn861; Calibrated: 2010/1/22
- Phantom: SAM 12; Type: SAM V4.0; Serial: TP 1202
- Measurement SW: DASY4, V4.7 Build 80; Postprocessing SW: SEMCAD, V1.8 Build 186

Mid Channel 190 /Area Scan (7x11x1): Measurement grid: dx=15mm, dy=15mm

Maximum value of SAR (measured) = 0.306 mW/g

Mid Channel 190 /Zoom Scan (7x7x9)/Cube 0: Measurement grid: dx=5mm, dy=5mm, dz=3mm

Reference Value = 13.1 V/m; Power Drift = 0.012 dB

Peak SAR (extrapolated) = 0.356 W/kg

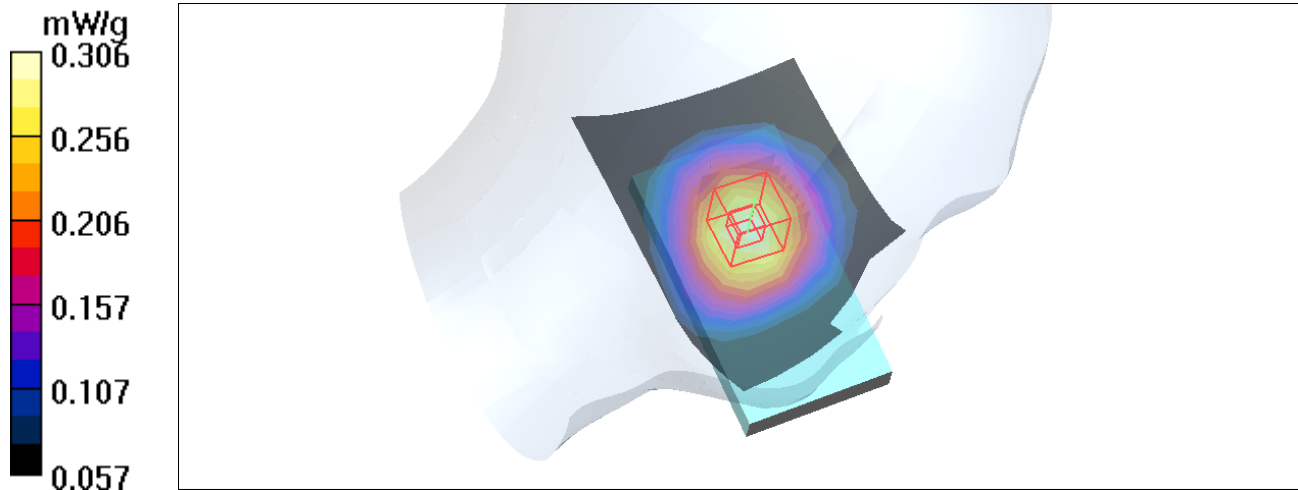
SAR(1 g) = **0.277** mW/g; SAR(10 g) = 0.207 mW/g

Test Laboratory: Bureau Veritas ADT

M05-Right Head Cheek- GSM 1900-Ch661

DUT: GSM/EGPRS Mobile Phone ; Type: EX128

Communication System: PCS 1900 ; Frequency: 1880 MHz ; Duty Cycle: 1:8.3

Medium: HSL1900 Medium parameters used: $f = 1880$ MHz; $\sigma = 1.42$ mho/m; $\epsilon_r = 40.37$; $\rho = 1000$ kg/m³

Phantom section: Right Section ; DUT test position : Cheek ; Modulation type: GMSK

DASY4 Configuration:

- Probe: EX3DV4 - SN3590 ; ConvF(8.33, 8.33, 8.33) ; Calibrated: 2010/3/25
- Sensor-Surface: 3mm (Mechanical Surface Detection)
- Electronics: DAE4 Sn861; Calibrated: 2010/1/22
- Phantom: SAM 12; Type: SAM V4.0; Serial: TP 1202
- Measurement SW: DASY4, V4.7 Build 80; Postprocessing SW: SEMCAD, V1.8 Build 186

Mid Channel 661 /Area Scan (7x11x1): Measurement grid: dx=15mm, dy=15mm

Maximum value of SAR (measured) = 0.710 mW/g

Mid Channel 661 /Zoom Scan (7x7x9)/Cube 0: Measurement grid: dx=5mm, dy=5mm, dz=3mm

Reference Value = 7.34 V/m; Power Drift = 0.044 dB

Peak SAR (extrapolated) = 0.939 W/kg

SAR(1 g) = 0.603 mW/g; SAR(10 g) = 0.358 mW/g

Maximum value of SAR (measured) = 0.718 mW/g

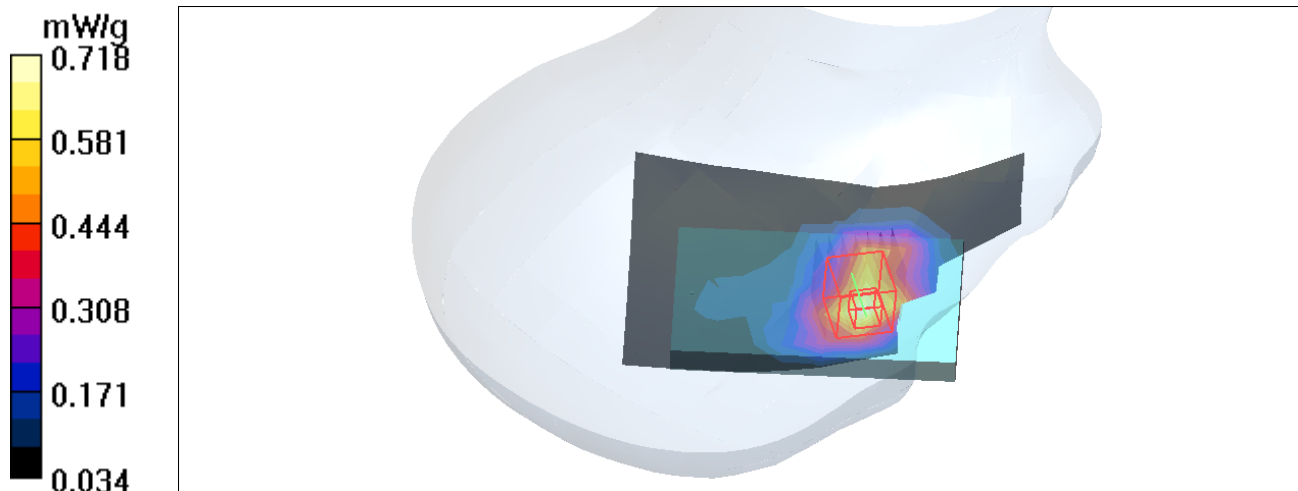

Test Laboratory: Bureau Veritas ADT

M06-Right Head Tilt- GSM 1900-Ch661

DUT: GSM/EGPRS Mobile Phone ; Type: EX128

Communication System: PCS 1900 ; Frequency: 1880 MHz ; Duty Cycle: 1:8.3

Medium: HSL1900 Medium parameters used: $f = 1880$ MHz; $\sigma = 1.42$ mho/m; $\epsilon_r = 40.37$; $\rho = 1000$ kg/m³

Phantom section: Right Section ; DUT test position : Tilt ; Modulation type: GMSK

DASY4 Configuration:

- Probe: EX3DV4 - SN3590 ; ConvF(8.33, 8.33, 8.33) ; Calibrated: 2010/3/25
- Sensor-Surface: 3mm (Mechanical Surface Detection)
- Electronics: DAE4 Sn861; Calibrated: 2010/1/22
- Phantom: SAM 12; Type: SAM V4.0; Serial: TP 1202
- Measurement SW: DASY4, V4.7 Build 80; Postprocessing SW: SEMCAD, V1.8 Build 186

Mid Channel 661 /Area Scan (7x11x1): Measurement grid: dx=15mm, dy=15mm

Maximum value of SAR (measured) = 0.238 mW/g

Mid Channel 661 /Zoom Scan (7x7x9)/Cube 0: Measurement grid: dx=5mm, dy=5mm, dz=3mm

Reference Value = 13.7 V/m; Power Drift = -0.062 dB

Peak SAR (extrapolated) = 0.373 W/kg

SAR(1 g) = **0.225 mW/g**; SAR(10 g) = **0.129 mW/g**

Maximum value of SAR (measured) = 0.275 mW/g

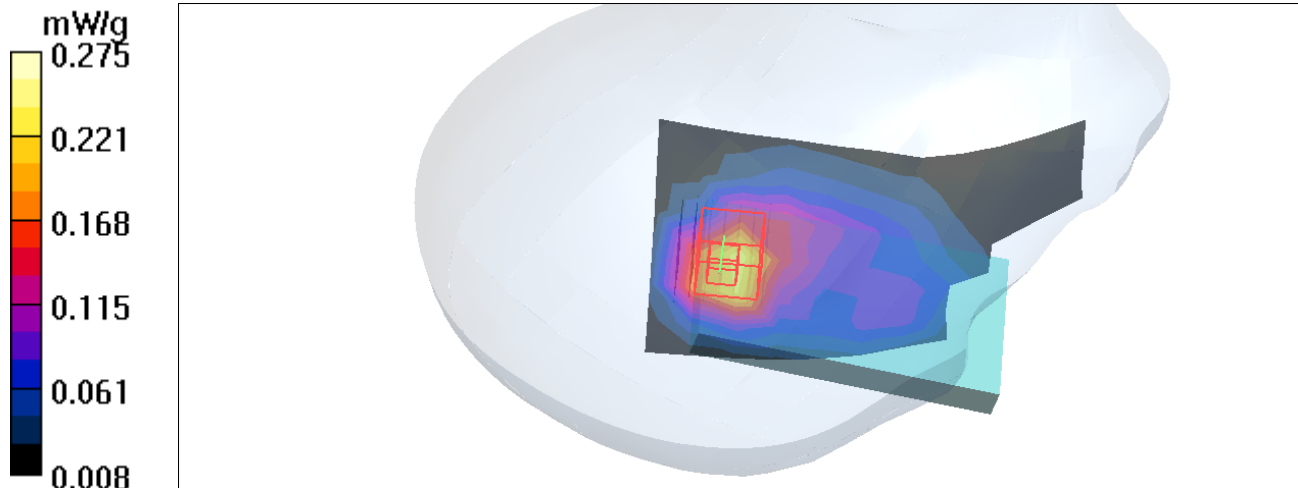

Test Laboratory: Bureau Veritas ADT

M07-Left Head Cheek- GSM 1900-Ch661

DUT: GSM/EGPRS Mobile Phone ; Type: EX128

Communication System: PCS 1900 ; Frequency: 1880 MHz ; Duty Cycle: 1:8.3

Medium: HSL1900 Medium parameters used: $f = 1880$ MHz; $\sigma = 1.42$ mho/m; $\epsilon_r = 40.37$; $\rho = 1000$ kg/m³

Phantom section: Left Section ; DUT test position : Cheek ; Modulation type: GMSK

DASY4 Configuration:

- Probe: EX3DV4 - SN3590 ; ConvF(8.33, 8.33, 8.33) ; Calibrated: 2010/3/25
- Sensor-Surface: 3mm (Mechanical Surface Detection)
- Electronics: DAE4 Sn861; Calibrated: 2010/1/22
- Phantom: SAM 12; Type: SAM V4.0; Serial: TP 1202
- Measurement SW: DASY4, V4.7 Build 80; Postprocessing SW: SEMCAD, V1.8 Build 186

Mid Channel 661 /Area Scan (7x11x1): Measurement grid: dx=15mm, dy=15mm

Maximum value of SAR (measured) = 0.735 mW/g

Mid Channel 661 /Zoom Scan (7x7x9)/Cube 0: Measurement grid: dx=5mm, dy=5mm, dz=3mm

Reference Value = 7.02 V/m; Power Drift = 0.044 dB

Peak SAR (extrapolated) = 1.24 W/kg

SAR(1 g) = 0.733 mW/g; SAR(10 g) = 0.398 mW/g

Maximum value of SAR (measured) = 0.910 mW/g

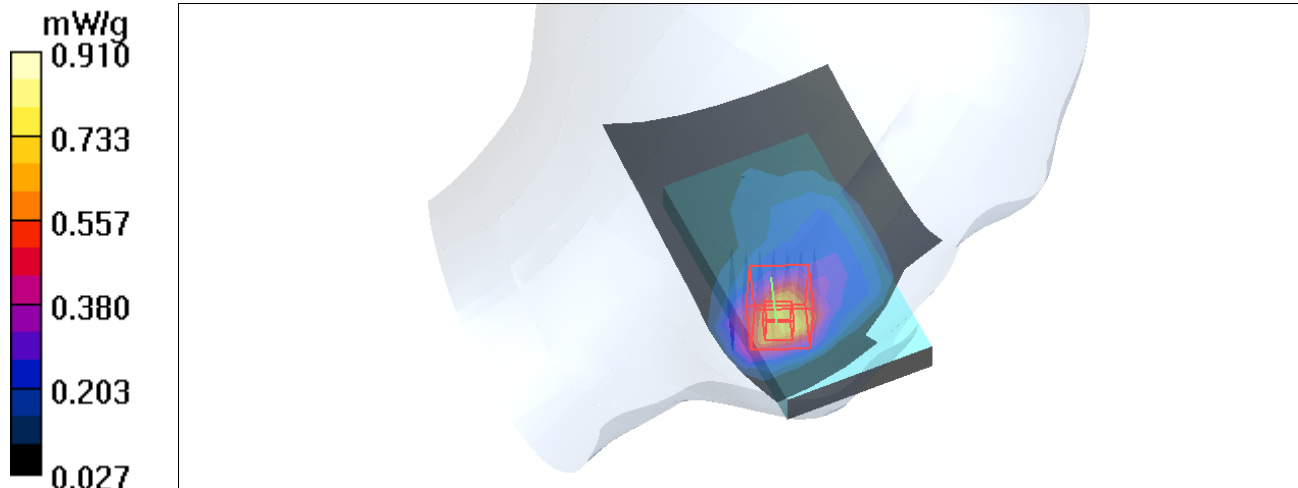

Test Laboratory: Bureau Veritas ADT

M08-Left Head Tilt- GSM 1900-Ch661

DUT: GSM/EGPRS Mobile Phone ; Type: EX128

Communication System: PCS 1900 ; Frequency: 1880 MHz ; Duty Cycle: 1:8.3

Medium: HSL1900 Medium parameters used: $f = 1880$ MHz; $\sigma = 1.42$ mho/m; $\epsilon_r = 40.37$; $\rho = 1000$ kg/m³

Phantom section: Left Section ; DUT test position : Tilt ; Modulation type: GMSK

DASY4 Configuration:

- Probe: EX3DV4 - SN3590 ; ConvF(8.33, 8.33, 8.33) ; Calibrated: 2010/3/25
- Sensor-Surface: 3mm (Mechanical Surface Detection)
- Electronics: DAE4 Sn861; Calibrated: 2010/1/22
- Phantom: SAM 12; Type: SAM V4.0; Serial: TP 1202
- Measurement SW: DASY4, V4.7 Build 80; Postprocessing SW: SEMCAD, V1.8 Build 186

Mid Channel 661 /Area Scan (7x11x1): Measurement grid: dx=15mm, dy=15mm

Maximum value of SAR (measured) = 0.247 mW/g

Mid Channel 661 /Zoom Scan (7x7x9)/Cube 0: Measurement grid: dx=5mm, dy=5mm, dz=3mm

Reference Value = 12.8 V/m; Power Drift = -0.172 dB

Peak SAR (extrapolated) = 0.335 W/kg

SAR(1 g) = 0.206 mW/g; SAR(10 g) = 0.122 mW/g

Maximum value of SAR (measured) = 0.245 mW/g

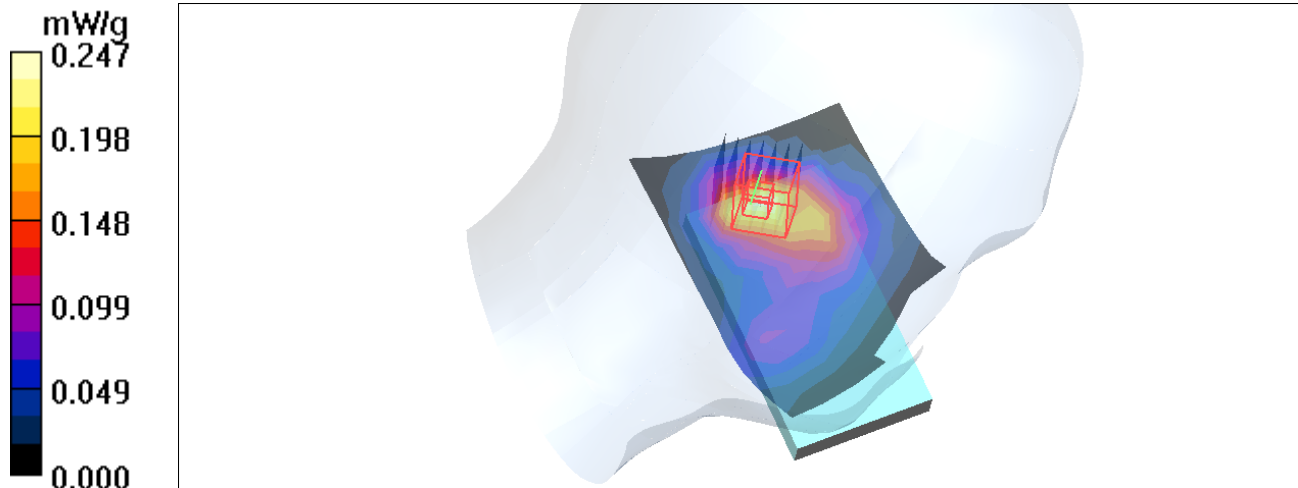

Test Laboratory: Bureau Veritas ADT

M09-Body Front- GSM 850-Ch190

DUT: GSM/EGPRS Mobile Phone ; Type: EX128

Communication System: GSM 850 ; Frequency: 836.6 MHz ; Duty Cycle: 1:8.3 ; Modulation type: GMSK

Medium: MSL835 Medium parameters used: $f = 836.6$ MHz; $\sigma = 0.96$ mho/m; $\epsilon_r = 53.4$; $\rho = 1000$ kg/m³
Phantom section: Flat Section ; Separation distance : 15 mm (The Front side of the EUT to the Phantom)

DASY4 Configuration:

- Probe: EX3DV4 - SN3590 ; ConvF(10.2, 10.2, 10.2) ; Calibrated: 2010/3/25
- Sensor-Surface: 3mm (Mechanical Surface Detection)
- Electronics: DAE4 Sn861 ; Calibrated: 2010/1/22
- Phantom: SAM 12 ; Type: SAM V4.0 ; Serial: TP 1202
- Measurement SW: DASY4, V4.7 Build 80 ; Postprocessing SW: SEMCAD, V1.8 Build 186

Mid Channel 190/Area Scan (6x11x1): Measurement grid: dx=15mm, dy=15mm

Maximum value of SAR (measured) = 0.356 mW/g

Mid Channel 190/Zoom Scan (7x7x9)/Cube 0: Measurement grid: dx=5mm, dy=5mm, dz=3mm

Reference Value = 18.0 V/m; Power Drift = -0.039 dB

Peak SAR (extrapolated) = 0.446 W/kg

SAR(1 g) = **0.321 mW/g**; SAR(10 g) = **0.225 mW/g**

Maximum value of SAR (measured) = 0.366 mW/g

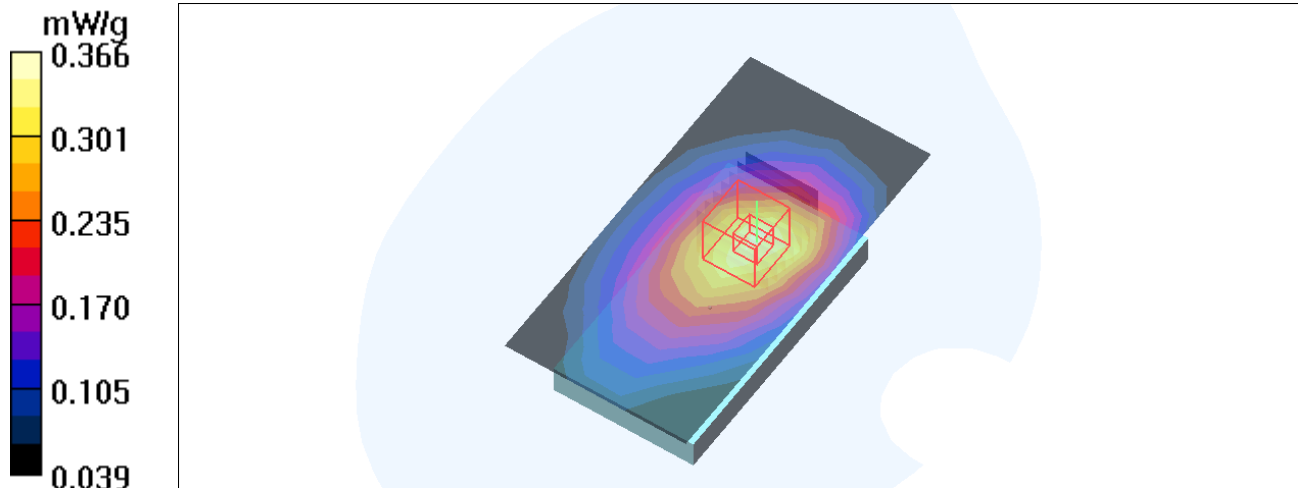

Test Laboratory: Bureau Veritas ADT

M10-Body Bottom - GSM 850-Ch190

DUT: GSM/EGPRS Mobile Phone ; Type: EX128

Communication System: GSM 850 ; Frequency: 836.6 MHz ; Duty Cycle: 1:8.3 ; Modulation type: GMSK

Medium: MSL835 Medium parameters used: $f = 836.6$ MHz; $\sigma = 0.96$ mho/m; $\epsilon_r = 53.4$; $\rho = 1000$ kg/m³

Phantom section: Flat Section ; Separation distance : 15 mm (The Bottom side of the EUT to the Phantom)

DASY4 Configuration:

- Probe: EX3DV4 - SN3590 ; ConvF(10.2, 10.2, 10.2) ; Calibrated: 2010/3/25
- Sensor-Surface: 3mm (Mechanical Surface Detection)
- Electronics: DAE4 Sn861 ; Calibrated: 2010/1/22
- Phantom: SAM 12 ; Type: SAM V4.0; Serial: TP 1202
- Measurement SW: DASY4, V4.7 Build 80 ; Postprocessing SW: SEMCAD, V1.8 Build 186

Mid Channel 190/Area Scan (6x11x1): Measurement grid: dx=15mm, dy=15mm

Maximum value of SAR (measured) = 0.436 mW/g

Mid Channel 190/Zoom Scan (7x7x9)/Cube 0: Measurement grid: dx=5mm, dy=5mm, dz=3mm

Reference Value = 20.8 V/m; Power Drift = 0.064 dB

Peak SAR (extrapolated) = 0.575 W/kg

SAR(1 g) = **0.402 mW/g**; SAR(10 g) = 0.282 mW/g

Maximum value of SAR (measured) = 0.457 mW/g

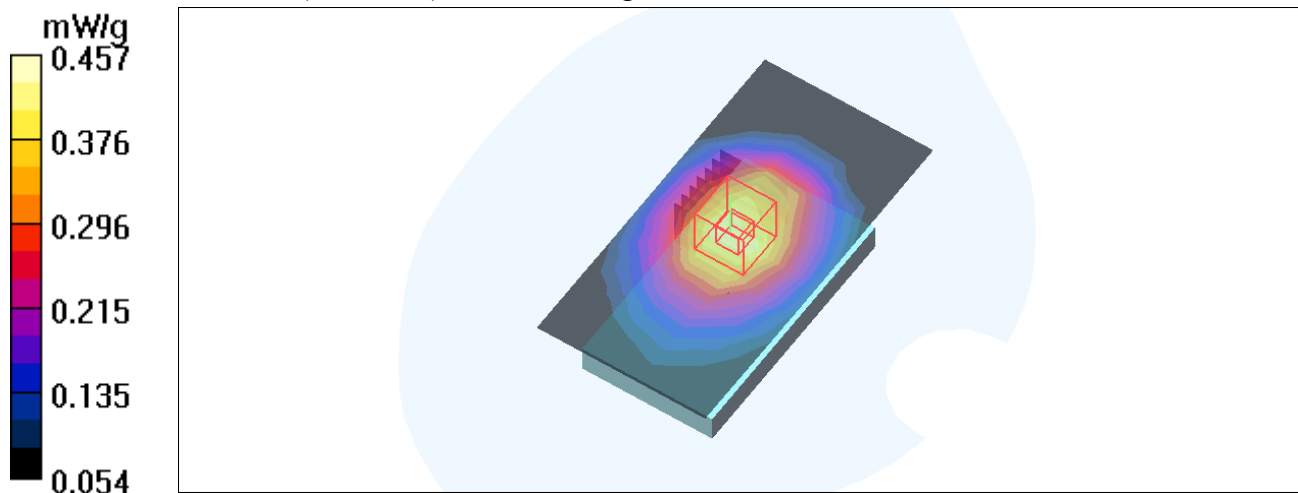

Test Laboratory: Bureau Veritas ADT

M11-Body Front - GPRS 850 TS1-Ch190

DUT: GSM/EGPRS Mobile Phone ; Type: EX128

Communication System: GSM 850 ; Frequency: 836.6 MHz ; Duty Cycle: 1:8.3 ; Modulation type: GMSK

Medium: MSL835 Medium parameters used: $f = 836.6$ MHz; $\sigma = 0.96$ mho/m; $\epsilon_r = 53.4$; $\rho = 1000$ kg/m³
Phantom section: Flat Section ; Separation distance : 15 mm (The Front side of the EUT to the Phantom)

DASY4 Configuration:

- Probe: EX3DV4 - SN3590 ; ConvF(10.2, 10.2, 10.2) ; Calibrated: 2010/3/25
- Sensor-Surface: 3mm (Mechanical Surface Detection)
- Electronics: DAE4 Sn861 ; Calibrated: 2010/1/22
- Phantom: SAM 12 ; Type: SAM V4.0 ; Serial: TP 1202
- Measurement SW: DASY4, V4.7 Build 80 ; Postprocessing SW: SEMCAD, V1.8 Build 186

Mid Channel 190/Area Scan (6x11x1): Measurement grid: dx=15mm, dy=15mm

Maximum value of SAR (measured) = 0.506 mW/g

Mid Channel 190/Zoom Scan (7x7x9)/Cube 0: Measurement grid: dx=5mm, dy=5mm, dz=3mm

Reference Value = 22.4 V/m; Power Drift = -0.182 dB

Peak SAR (extrapolated) = 0.458 W/kg

SAR(1 g) = **0.256 mW/g**; SAR(10 g) = **0.180 mW/g**

Maximum value of SAR (measured) = 0.358 mW/g

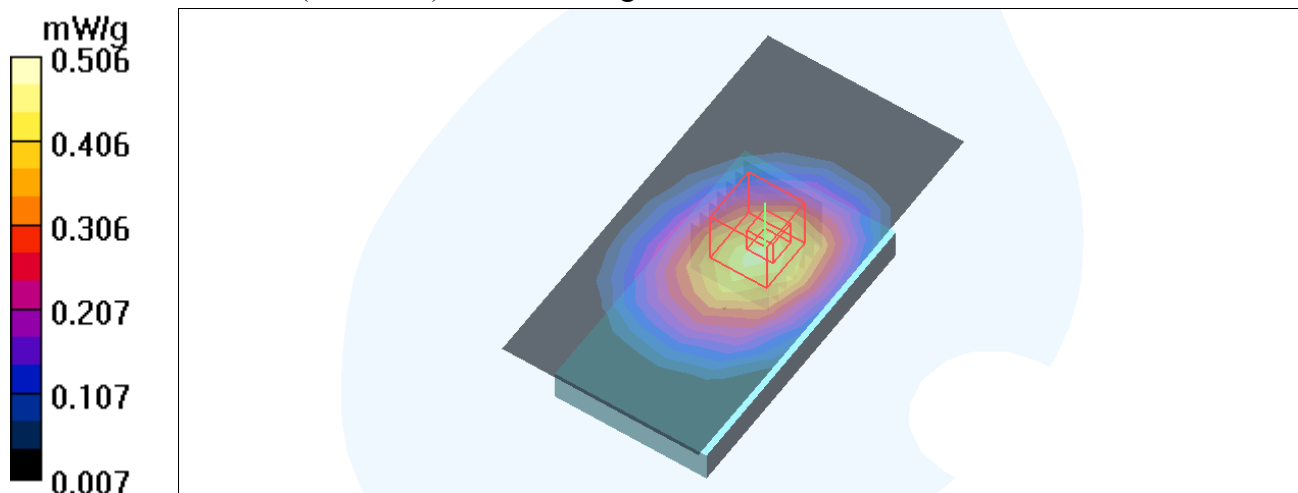

Test Laboratory: Bureau Veritas ADT

M12-Body Bottom - GPRS 850 TS1-Ch190

DUT: GSM/EGPRS Mobile Phone ; Type: EX128

Communication System: GSM 850 ; Frequency: 836.6 MHz ; Duty Cycle: 1:8.3 ; Modulation type: GMSK

Medium: MSL835 Medium parameters used: $f = 836.6$ MHz; $\sigma = 0.96$ mho/m; $\epsilon_r = 53.4$; $\rho = 1000$ kg/m³

Phantom section: Flat Section ; Separation distance : 15 mm (The Bottom side of the EUT to the Phantom)

DASY4 Configuration:

- Probe: EX3DV4 - SN3590 ; ConvF(10.2, 10.2, 10.2) ; Calibrated: 2010/3/25
- Sensor-Surface: 3mm (Mechanical Surface Detection)
- Electronics: DAE4 Sn861 ; Calibrated: 2010/1/22
- Phantom: SAM 12 ; Type: SAM V4.0 ; Serial: TP 1202
- Measurement SW: DASY4, V4.7 Build 80 ; Postprocessing SW: SEMCAD, V1.8 Build 186

Mid Channel 190/Area Scan (6x11x1): Measurement grid: dx=15mm, dy=15mm

Maximum value of SAR (measured) = 0.416 mW/g

Mid Channel 190/Zoom Scan (7x7x9)/Cube 0: Measurement grid: dx=5mm, dy=5mm, dz=3mm

Reference Value = 20.5 V/m; Power Drift = -0.101 dB

Peak SAR (extrapolated) = 0.533 W/kg

SAR(1 g) = **0.380** mW/g; SAR(10 g) = 0.267 mW/g

Maximum value of SAR (measured) = 0.432 mW/g

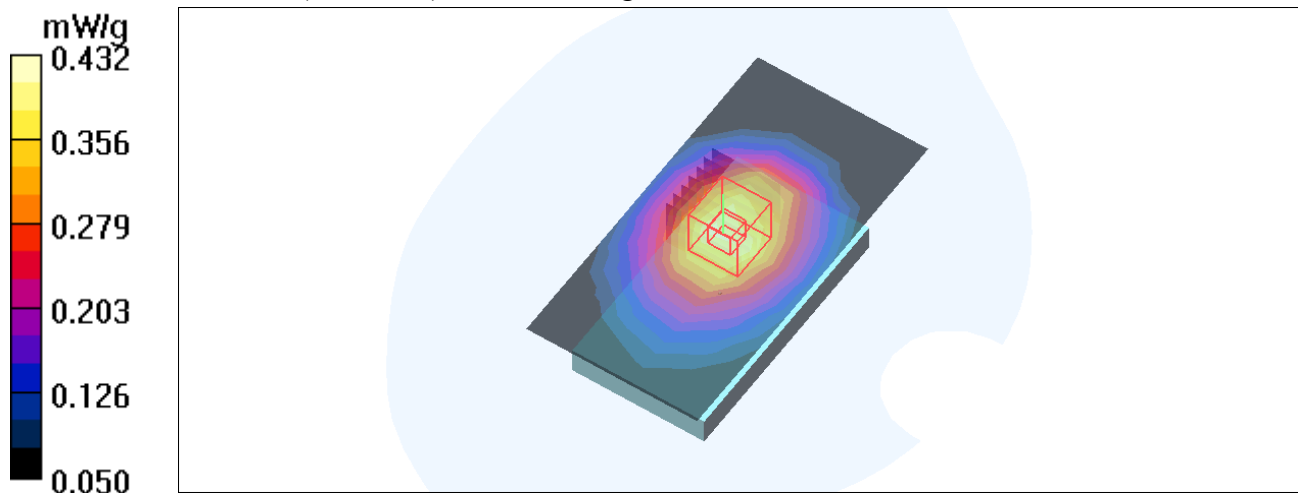

Test Laboratory: Bureau Veritas ADT

M13-Body Front - GPRS 850 TS2-Ch190

DUT: GSM/EGPRS Mobile Phone ; Type: EX128

Communication System: GSM 850 ; Frequency: 836.6 MHz ; Duty Cycle: 1:4 ; Modulation type: GMSK
Medium: MSL835 Medium parameters used: $f = 836.6$ MHz; $\sigma = 0.96$ mho/m; $\epsilon_r = 53.4$; $\rho = 1000$ kg/m³
Phantom section: Flat Section ; Separation distance : 15 mm (The Front side of the EUT to the Phantom)

DASY4 Configuration:

- Probe: EX3DV4 - SN3590 ; ConvF(10.2, 10.2, 10.2) ; Calibrated: 2010/3/25
- Sensor-Surface: 3mm (Mechanical Surface Detection)
- Electronics: DAE4 Sn861 ; Calibrated: 2010/1/22
- Phantom: SAM 12 ; Type: SAM V4.0 ; Serial: TP 1202
- Measurement SW: DASY4, V4.7 Build 80 ; Postprocessing SW: SEMCAD, V1.8 Build 186

Mid Channel 190/Area Scan (6x11x1): Measurement grid: dx=15mm, dy=15mm

Maximum value of SAR (measured) = 0.590 mW/g

Mid Channel 190/Zoom Scan (7x7x9)/Cube 0: Measurement grid: dx=5mm, dy=5mm, dz=3mm

Reference Value = 23.2 V/m; Power Drift = -0.011 dB

Peak SAR (extrapolated) = 0.754 W/kg

SAR(1 g) = 0.533 mW/g; SAR(10 g) = 0.375 mW/g

Maximum value of SAR (measured) = 0.605 mW/g

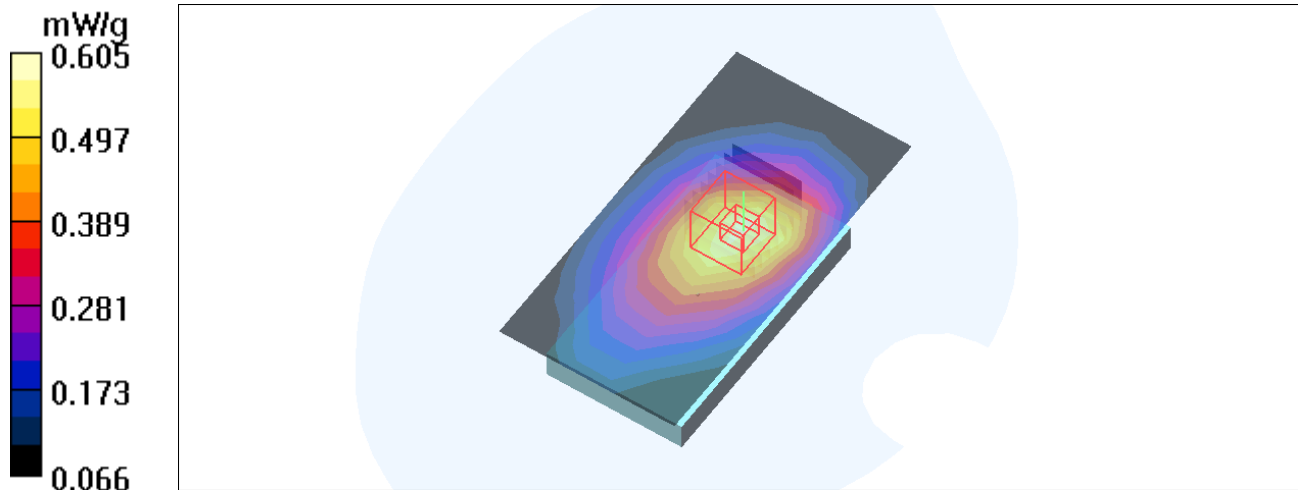

Test Laboratory: Bureau Veritas ADT

M14-Body Bottom - GPRS 850 TS2-Ch190

DUT: GSM/EGPRS Mobile Phone ; Type: EX128

Communication System: GSM 850 ; Frequency: 836.6 MHz ; Duty Cycle: 1:4 ; Modulation type: GMSK
Medium: MSL835 Medium parameters used: $f = 836.6$ MHz; $\sigma = 0.96$ mho/m; $\epsilon_r = 53.4$; $\rho = 1000$ kg/m³
Phantom section: Flat Section ; Separation distance : 15 mm (The Bottom side of the EUT to the Phantom)

DASY4 Configuration:

- Probe: EX3DV4 - SN3590 ; ConvF(10.2, 10.2, 10.2) ; Calibrated: 2010/3/25
- Sensor-Surface: 3mm (Mechanical Surface Detection)
- Electronics: DAE4 Sn861 ; Calibrated: 2010/1/22
- Phantom: SAM 12 ; Type: SAM V4.0 ; Serial: TP 1202
- Measurement SW: DASY4, V4.7 Build 80 ; Postprocessing SW: SEMCAD, V1.8 Build 186

Mid Channel 190/Area Scan (6x11x1): Measurement grid: dx=15mm, dy=15mm

Maximum value of SAR (measured) = 0.811 mW/g

Mid Channel 190/Zoom Scan (7x7x9)/Cube 0: Measurement grid: dx=5mm, dy=5mm, dz=3mm

Reference Value = 28.7 V/m; Power Drift = 0.019 dB

Peak SAR (extrapolated) = 1.01 W/kg

SAR(1 g) = **0.737** mW/g; SAR(10 g) = **0.523** mW/g

Maximum value of SAR (measured) = 0.828 mW/g

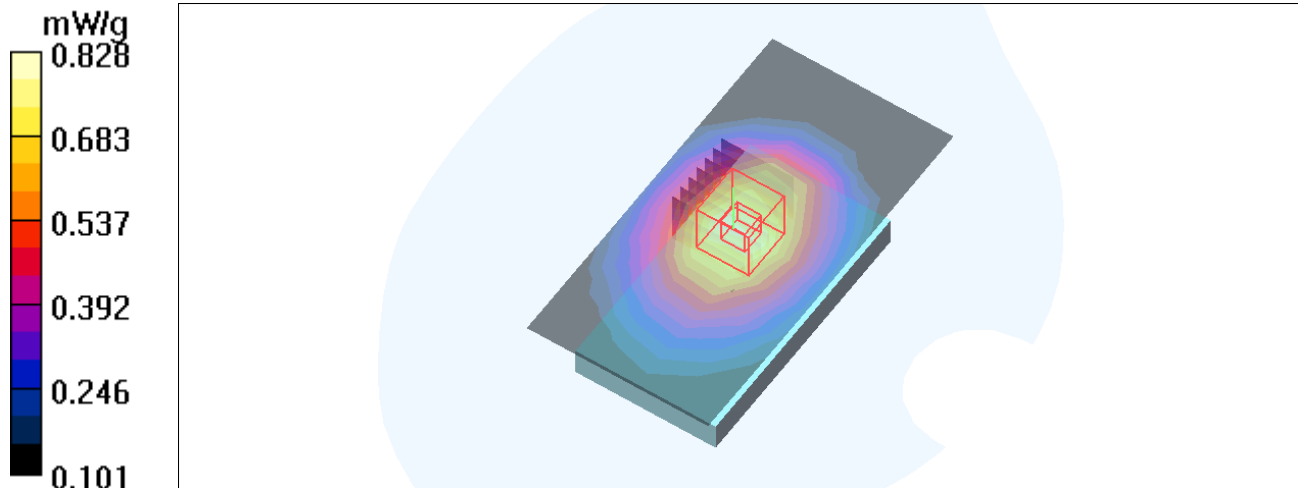

Test Laboratory: Bureau Veritas ADT

M15-Body Front -EGPRS 850 TS1-Ch190

DUT: GSM/EGPRS Mobile Phone ; Type: EX128

Communication System: GSM 850 ; Frequency: 836.6 MHz ; Duty Cycle: 1:8.3 ; Modulation type: 8PSK
Medium: MSL835 Medium parameters used: $f = 836.6$ MHz; $\sigma = 0.96$ mho/m; $\epsilon_r = 53.4$; $\rho = 1000$ kg/m³
Phantom section: Flat Section ; Separation distance : 15 mm (The Front side of the EUT to the Phantom)

DASY4 Configuration:

- Probe: EX3DV4 - SN3590 ; ConvF(10.2, 10.2, 10.2) ; Calibrated: 2010/3/25
- Sensor-Surface: 3mm (Mechanical Surface Detection)
- Electronics: DAE4 Sn861 ; Calibrated: 2010/1/22
- Phantom: SAM 12 ; Type: SAM V4.0 ; Serial: TP 1202
- Measurement SW: DASY4, V4.7 Build 80 ; Postprocessing SW: SEMCAD, V1.8 Build 186

Mid Channel 190/Area Scan (6x11x1): Measurement grid: dx=15mm, dy=15mm

Maximum value of SAR (measured) = 0.137 mW/g

Mid Channel 190/Zoom Scan (7x7x9)/Cube 0: Measurement grid: dx=5mm, dy=5mm, dz=3mm

Reference Value = 11.6 V/m; Power Drift = 0.098 dB

Peak SAR (extrapolated) = 0.179 W/kg

SAR(1 g) = **0.126 mW/g**; SAR(10 g) = **0.088 mW/g**

Maximum value of SAR (measured) = 0.143 mW/g

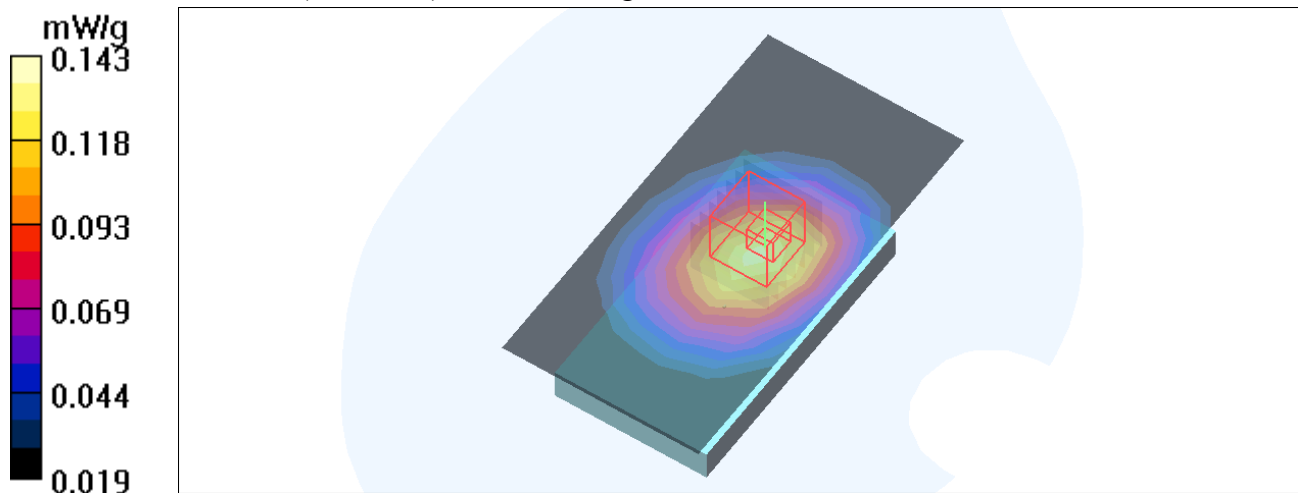

Test Laboratory: Bureau Veritas ADT

M16-Body Bottom - EGPRS 850 TS1-Ch190

DUT: GSM/EGPRS Mobile Phone ; Type: EX128

Communication System: GSM 850 ; Frequency: 836.6 MHz ; Duty Cycle: 1:8.3 ; Modulation type: 8PSK
Medium: MSL835 Medium parameters used: $f = 836.6$ MHz; $\sigma = 0.96$ mho/m; $\epsilon_r = 53.4$; $\rho = 1000$ kg/m³
Phantom section: Flat Section ; Separation distance : 15 mm (The Bottom side of the EUT to the Phantom)

DASY4 Configuration:

- Probe: EX3DV4 - SN3590 ; ConvF(10.2, 10.2, 10.2) ; Calibrated: 2010/3/25
- Sensor-Surface: 3mm (Mechanical Surface Detection)
- Electronics: DAE4 Sn861 ; Calibrated: 2010/1/22
- Phantom: SAM 12 ; Type: SAM V4.0 ; Serial: TP 1202
- Measurement SW: DASY4, V4.7 Build 80 ; Postprocessing SW: SEMCAD, V1.8 Build 186

Mid Channel 190/Area Scan (6x11x1): Measurement grid: dx=15mm, dy=15mm

Maximum value of SAR (measured) = 0.179 mW/g

Mid Channel 190/Zoom Scan (7x7x9)/Cube 0: Measurement grid: dx=5mm, dy=5mm, dz=3mm

Reference Value = 13.2 V/m; Power Drift = 0.040 dB

Peak SAR (extrapolated) = 0.219 W/kg

SAR(1 g) = **0.160** mW/g; SAR(10 g) = 0.115 mW/g

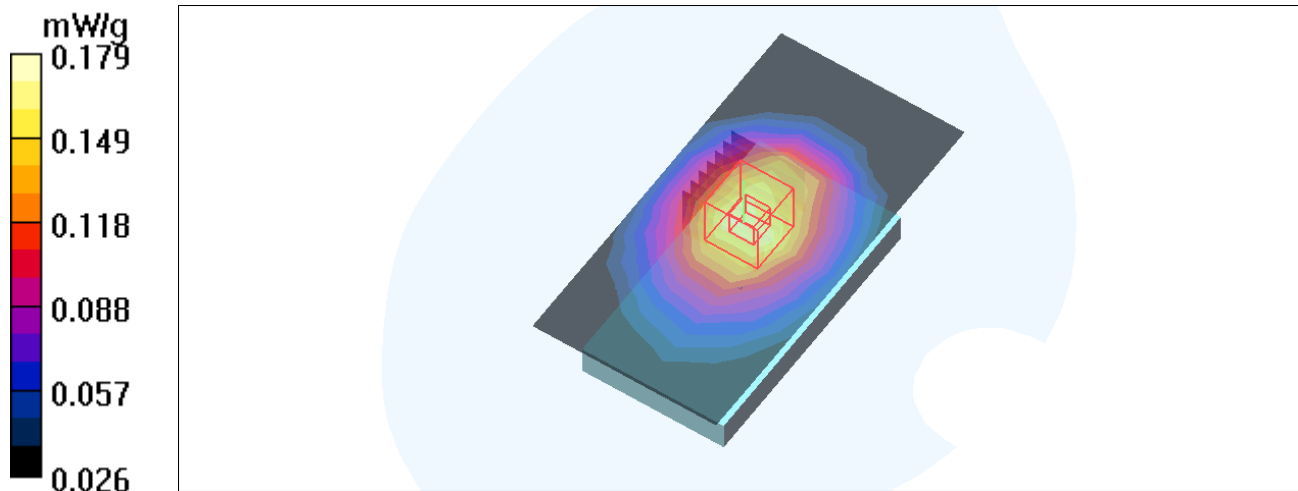

Test Laboratory: Bureau Veritas ADT

M17-Body Front - EGPRS 850 TS2-Ch190

DUT: GSM/EGPRS Mobile Phone ; Type: EX128

Communication System: GSM 850 ; Frequency: 836.6 MHz ; Duty Cycle: 1:4 ; Modulation type: 8PSK
Medium: MSL835 Medium parameters used: $f = 836.6$ MHz; $\sigma = 0.96$ mho/m; $\epsilon_r = 53.4$; $\rho = 1000$ kg/m³
Phantom section: Flat Section ; Separation distance : 15 mm (The Front side of the EUT to the Phantom)

DASY4 Configuration:

- Probe: EX3DV4 - SN3590 ; ConvF(10.2, 10.2, 10.2) ; Calibrated: 2010/3/25
- Sensor-Surface: 3mm (Mechanical Surface Detection)
- Electronics: DAE4 Sn861 ; Calibrated: 2010/1/22
- Phantom: SAM 12 ; Type: SAM V4.0 ; Serial: TP 1202
- Measurement SW: DASY4, V4.7 Build 80 ; Postprocessing SW: SEMCAD, V1.8 Build 186

Mid Channel 190/Area Scan (6x11x1): Measurement grid: dx=15mm, dy=15mm

Maximum value of SAR (measured) = 0.357 mW/g

Mid Channel 190/Zoom Scan (7x7x9)/Cube 0: Measurement grid: dx=5mm, dy=5mm, dz=3mm

Reference Value = 18.6 V/m; Power Drift = 0.010 dB

Peak SAR (extrapolated) = 0.425 W/kg

SAR(1 g) = **0.316** mW/g; SAR(10 g) = 0.227 mW/g

Maximum value of SAR (measured) = 0.354 mW/g

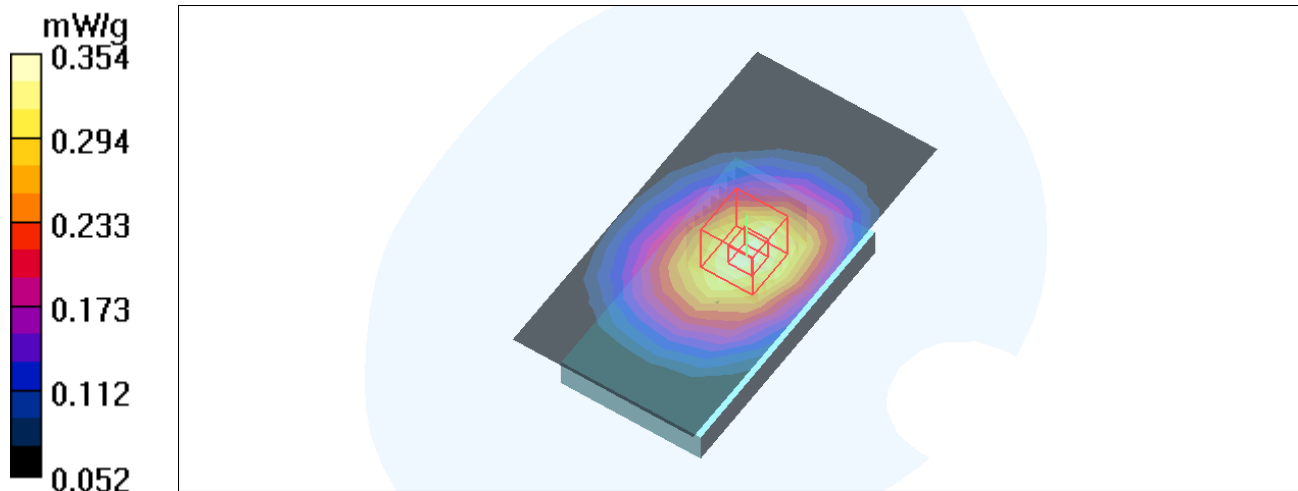

Test Laboratory: Bureau Veritas ADT

M18-Body Bottom - EGPRS 850 TS2-Ch190

DUT: GSM/EGPRS Mobile Phone ; Type: EX128

Communication System: GSM 850 ; Frequency: 836.6 MHz ; Duty Cycle: 1:4 ; Modulation type: 8PSK
Medium: MSL835 Medium parameters used: $f = 836.6$ MHz; $\sigma = 0.96$ mho/m; $\epsilon_r = 53.4$; $\rho = 1000$ kg/m³
Phantom section: Flat Section ; Separation distance : 15 mm (The Bottom side of the EUT to the Phantom)

DASY4 Configuration:

- Probe: EX3DV4 - SN3590 ; ConvF(10.2, 10.2, 10.2) ; Calibrated: 2010/3/25
- Sensor-Surface: 3mm (Mechanical Surface Detection)
- Electronics: DAE4 Sn861 ; Calibrated: 2010/1/22
- Phantom: SAM 12 ; Type: SAM V4.0 ; Serial: TP 1202
- Measurement SW: DASY4, V4.7 Build 80 ; Postprocessing SW: SEMCAD, V1.8 Build 186

Mid Channel 190/Area Scan (6x11x1): Measurement grid: dx=15mm, dy=15mm

Maximum value of SAR (measured) = 0.530 mW/g

Mid Channel 190/Zoom Scan (7x7x9)/Cube 0: Measurement grid: dx=5mm, dy=5mm, dz=3mm

Reference Value = 22.7 V/m; Power Drift = -0.088 dB

Peak SAR (extrapolated) = 0.666 W/kg

SAR(1 g) = **0.473 mW/g**; SAR(10 g) = **0.330 mW/g**

Maximum value of SAR (measured) = 0.537 mW/g

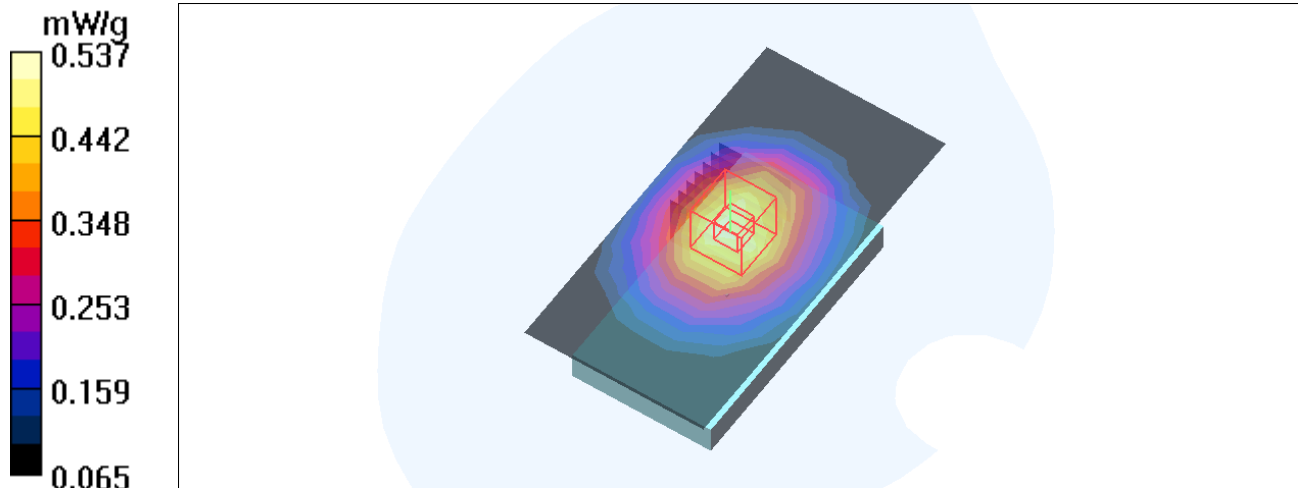

Test Laboratory: Bureau Veritas ADT

M19-Body Front - PCS 1900-Ch661

DUT: GSM/EGPRS Mobile Phone ; Type: EX128

Communication System: PCS 1900 ; Frequency: 1880 MHz ; Duty Cycle: 1:8.3 ; Modulation type: GMSK

Medium: MSL1900 Medium parameters used: $f = 1880$ MHz; $\sigma = 1.55$ mho/m; $\epsilon_r = 52.3$; $\rho = 1000$ kg/m³
Phantom section: Flat Section ; Separation distance : 15 mm (The Front side of the EUT to the Phantom)

DASY4 Configuration:

- Probe: EX3DV4 - SN3590 ; ConvF(8.61, 8.61, 8.61) ; Calibrated: 2010/3/25
- Sensor-Surface: 3mm (Mechanical Surface Detection)
- Electronics: DAE4 Sn861 ; Calibrated: 2010/1/22
- Phantom: SAM 12 ; Type: SAM V4.0 ; Serial: TP 1202
- Measurement SW: DASY4, V4.7 Build 80 ; Postprocessing SW: SEMCAD, V1.8 Build 186

Mid Channel 661/Area Scan (6x11x1): Measurement grid: dx=15mm, dy=15mm

Maximum value of SAR (measured) = 0.153 mW/g

Mid Channel 661/Zoom Scan (7x7x9)/Cube 0: Measurement grid: dx=5mm, dy=5mm, dz=3mm

Reference Value = 8.02 V/m; Power Drift = 0.142 dB

Peak SAR (extrapolated) = 0.230 W/kg

SAR(1 g) = **0.143 mW/g**; SAR(10 g) = **0.088 mW/g**

Maximum value of SAR (measured) = 0.170 mW/g

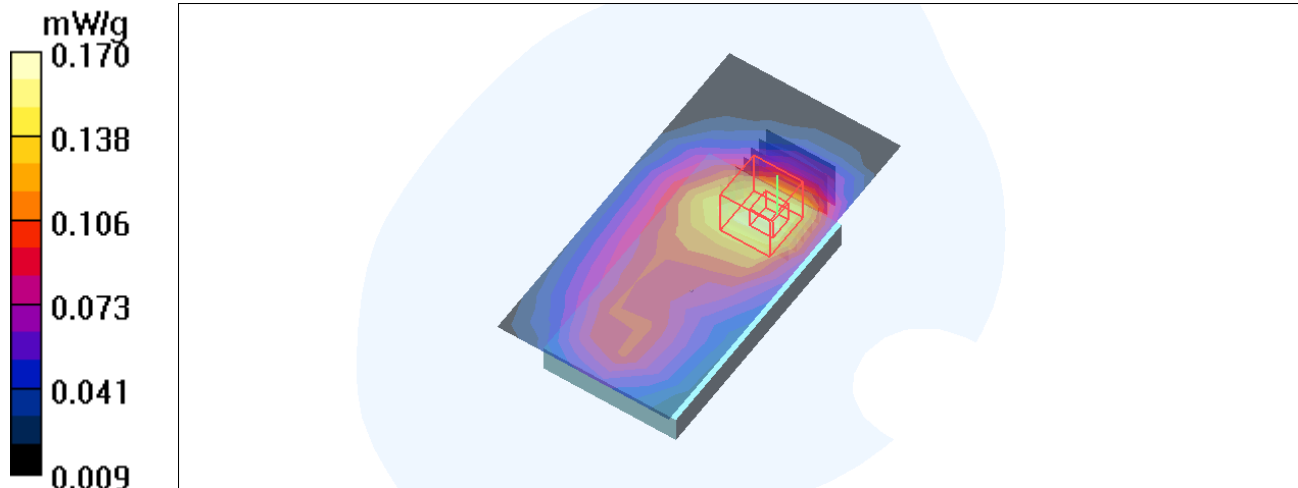

Test Laboratory: Bureau Veritas ADT

M20-Body Bottom - PCS 1900-Ch661

DUT: GSM/EGPRS Mobile Phone ; Type: EX128

Communication System: PCS 1900 ; Frequency: 1880 MHz ; Duty Cycle: 1:8.3 ; Modulation type: GMSK

Medium: MSL1900 Medium parameters used: $f = 1880$ MHz; $\sigma = 1.55$ mho/m; $\epsilon_r = 52.3$; $\rho = 1000$ kg/m³

Phantom section: Flat Section ; Separation distance : 15 mm (The Bottom side of the EUT to the Phantom)

DASY4 Configuration:

- Probe: EX3DV4 - SN3590 ; ConvF(8.61, 8.61, 8.61) ; Calibrated: 2010/3/25
- Sensor-Surface: 3mm (Mechanical Surface Detection)
- Electronics: DAE4 Sn861 ; Calibrated: 2010/1/22
- Phantom: SAM 12 ; Type: SAM V4.0 ; Serial: TP 1202
- Measurement SW: DASY4, V4.7 Build 80 ; Postprocessing SW: SEMCAD, V1.8 Build 186

Mid Channel 661/Area Scan (6x11x1): Measurement grid: dx=15mm, dy=15mm

Maximum value of SAR (measured) = 0.199 mW/g

Mid Channel 661/Zoom Scan (7x7x9)/Cube 0: Measurement grid: dx=5mm, dy=5mm, dz=3mm

Reference Value = 8.59 V/m; Power Drift = 0.110 dB

Peak SAR (extrapolated) = 0.324 W/kg

SAR(1 g) = **0.191 mW/g**; SAR(10 g) = 0.111 mW/g

Maximum value of SAR (measured) = 0.233 mW/g

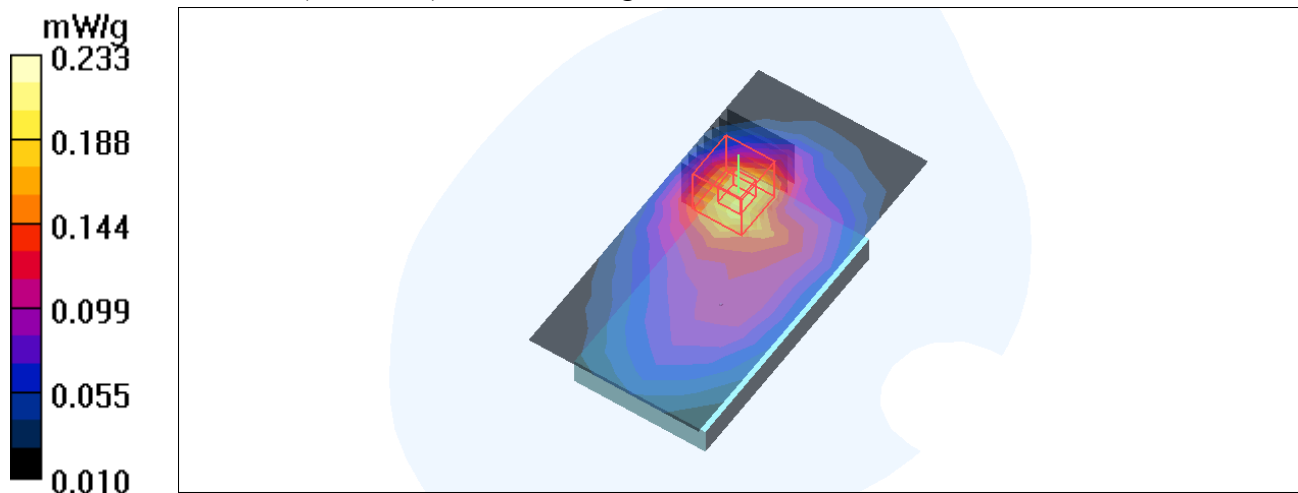

Test Laboratory: Bureau Veritas ADT

M21-Body Front - GPRS 1900 TS1-Ch661

DUT: GSM/EGPRS Mobile Phone ; Type: EX128

Communication System: PCS 1900 ; Frequency: 1880 MHz ; Duty Cycle: 1:8.3 ; Modulation type: GMSK

Medium: MSL1900 Medium parameters used: $f = 1880$ MHz; $\sigma = 1.55$ mho/m; $\epsilon_r = 52.3$; $\rho = 1000$ kg/m³
Phantom section: Flat Section ; Separation distance : 15 mm (The Front side of the EUT to the Phantom)

DASY4 Configuration:

- Probe: EX3DV4 - SN3590 ; ConvF(8.61, 8.61, 8.61) ; Calibrated: 2010/3/25
- Sensor-Surface: 3mm (Mechanical Surface Detection)
- Electronics: DAE4 Sn861 ; Calibrated: 2010/1/22
- Phantom: SAM 12 ; Type: SAM V4.0 ; Serial: TP 1202
- Measurement SW: DASY4, V4.7 Build 80 ; Postprocessing SW: SEMCAD, V1.8 Build 186

Mid Channel 661/Area Scan (6x11x1): Measurement grid: dx=15mm, dy=15mm

Maximum value of SAR (measured) = 0.142 mW/g

Mid Channel 661/Zoom Scan (7x7x9)/Cube 0: Measurement grid: dx=5mm, dy=5mm, dz=3mm

Reference Value = 7.67 V/m; Power Drift = 0.161 dB

Peak SAR (extrapolated) = 0.208 W/kg

SAR(1 g) = **0.131** mW/g; SAR(10 g) = **0.081** mW/g

Maximum value of SAR (measured) = 0.157 mW/g

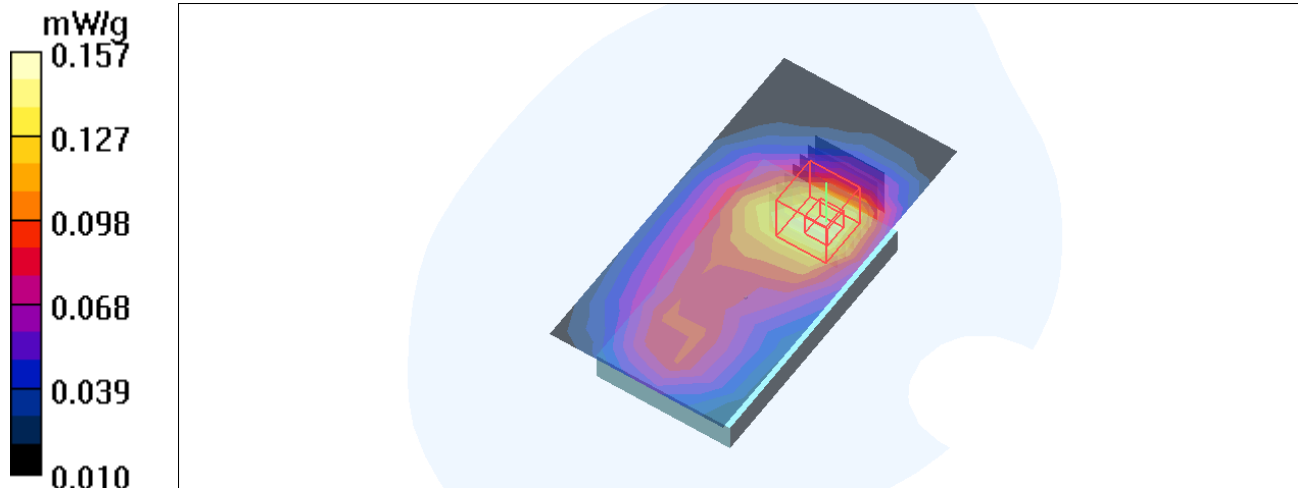

Test Laboratory: Bureau Veritas ADT

M22-Body Bottom - GPRS 1900 TS1-Ch661

DUT: GSM/EGPRS Mobile Phone ; Type: EX128

Communication System: PCS 1900 ; Frequency: 1880 MHz ; Duty Cycle: 1:8.3 ; Modulation type: GMSK

Medium: MSL1900 Medium parameters used: $f = 1880$ MHz; $\sigma = 1.55$ mho/m; $\epsilon_r = 52.3$; $\rho = 1000$ kg/m³

Phantom section: Flat Section ; Separation distance : 15 mm (The Bottom side of the EUT to the Phantom)

DASY4 Configuration:

- Probe: EX3DV4 - SN3590 ; ConvF(8.61, 8.61, 8.61) ; Calibrated: 2010/3/25
- Sensor-Surface: 3mm (Mechanical Surface Detection)
- Electronics: DAE4 Sn861 ; Calibrated: 2010/1/22
- Phantom: SAM 12 ; Type: SAM V4.0 ; Serial: TP 1202
- Measurement SW: DASY4, V4.7 Build 80 ; Postprocessing SW: SEMCAD, V1.8 Build 186

Mid Channel 661/Area Scan (6x11x1): Measurement grid: dx=15mm, dy=15mm

Maximum value of SAR (measured) = 0.187 mW/g

Mid Channel 661/Zoom Scan (7x7x9)/Cube 0: Measurement grid: dx=5mm, dy=5mm, dz=3mm

Reference Value = 8.31 V/m; Power Drift = 0.038 dB

Peak SAR (extrapolated) = 0.295 W/kg

SAR(1 g) = **0.175 mW/g**; SAR(10 g) = **0.102 mW/g**

Maximum value of SAR (measured) = 0.216 mW/g

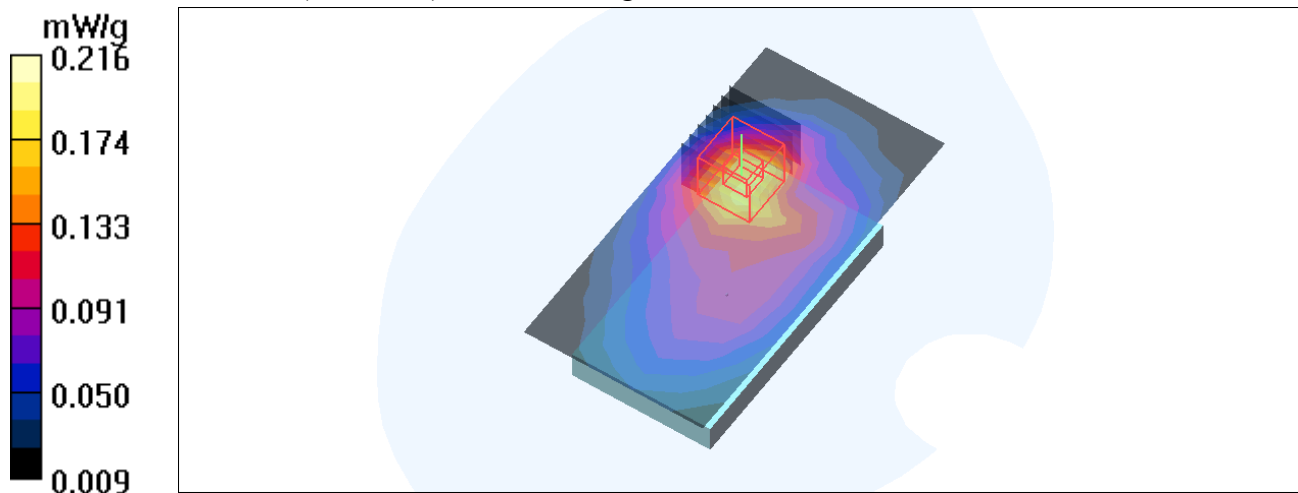

Test Laboratory: Bureau Veritas ADT

M23-Body Front - GPRS 1900 TS2-Ch661

DUT: GSM/EGPRS Mobile Phone ; Type: EX128

Communication System: PCS 1900 ; Frequency: 1880 MHz ; Duty Cycle: 1:4 ; Modulation type: GMSK
Medium: MSL1900 Medium parameters used: $f = 1880$ MHz; $\sigma = 1.55$ mho/m; $\epsilon_r = 52.3$; $\rho = 1000$ kg/m³
Phantom section: Flat Section ; Separation distance : 15 mm (The Front side of the EUT to the Phantom)

DASY4 Configuration:

- Probe: EX3DV4 - SN3590 ; ConvF(8.61, 8.61, 8.61) ; Calibrated: 2010/3/25
- Sensor-Surface: 3mm (Mechanical Surface Detection)
- Electronics: DAE4 Sn861 ; Calibrated: 2010/1/22
- Phantom: SAM 12 ; Type: SAM V4.0 ; Serial: TP 1202
- Measurement SW: DASY4, V4.7 Build 80 ; Postprocessing SW: SEMCAD, V1.8 Build 186

Mid Channel 661/Area Scan (6x11x1): Measurement grid: dx=15mm, dy=15mm

Maximum value of SAR (measured) = 0.239 mW/g

Mid Channel 661/Zoom Scan (7x7x9)/Cube 0: Measurement grid: dx=5mm, dy=5mm, dz=3mm

Reference Value = 9.96 V/m; Power Drift = -0.033 dB

Peak SAR (extrapolated) = 0.358 W/kg

SAR(1 g) = **0.222 mW/g**; SAR(10 g) = 0.136 mW/g

Maximum value of SAR (measured) = 0.263 mW/g

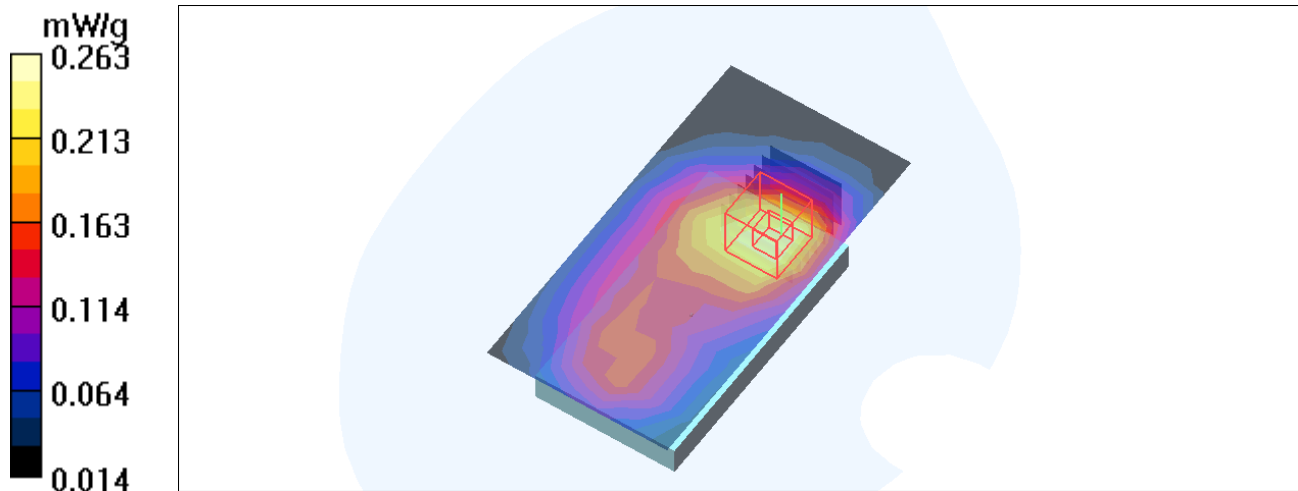

Test Laboratory: Bureau Veritas ADT

M24-Body Bottom- GPRS 1900 TS2-Ch661

DUT: GSM/EGPRS Mobile Phone ; Type: EX128

Communication System: PCS 1900 ; Frequency: 1880 MHz ; Duty Cycle: 1:4 ; Modulation type: GMSK
Medium: MSL1900 Medium parameters used: $f = 1880$ MHz; $\sigma = 1.55$ mho/m; $\epsilon_r = 52.3$; $\rho = 1000$ kg/m³
Phantom section: Flat Section ; Separation distance : 15 mm (The Bottom side of the EUT to the Phantom)

DASY4 Configuration:

- Probe: EX3DV4 - SN3590 ; ConvF(8.61, 8.61, 8.61) ; Calibrated: 2010/3/25
- Sensor-Surface: 3mm (Mechanical Surface Detection)
- Electronics: DAE4 Sn861 ; Calibrated: 2010/1/22
- Phantom: SAM 12 ; Type: SAM V4.0 ; Serial: TP 1202
- Measurement SW: DASY4, V4.7 Build 80 ; Postprocessing SW: SEMCAD, V1.8 Build 186

Mid Channel 661/Area Scan (6x11x1): Measurement grid: dx=15mm, dy=15mm

Maximum value of SAR (measured) = 0.323 mW/g

Mid Channel 661/Zoom Scan (7x7x9)/Cube 0: Measurement grid: dx=5mm, dy=5mm, dz=3mm

Reference Value = 11.0 V/m; Power Drift = -0.153 dB

Peak SAR (extrapolated) = 0.495 W/kg

SAR(1 g) = **0.296 mW/g**; SAR(10 g) = **0.173 mW/g**

Maximum value of SAR (measured) = 0.360 mW/g

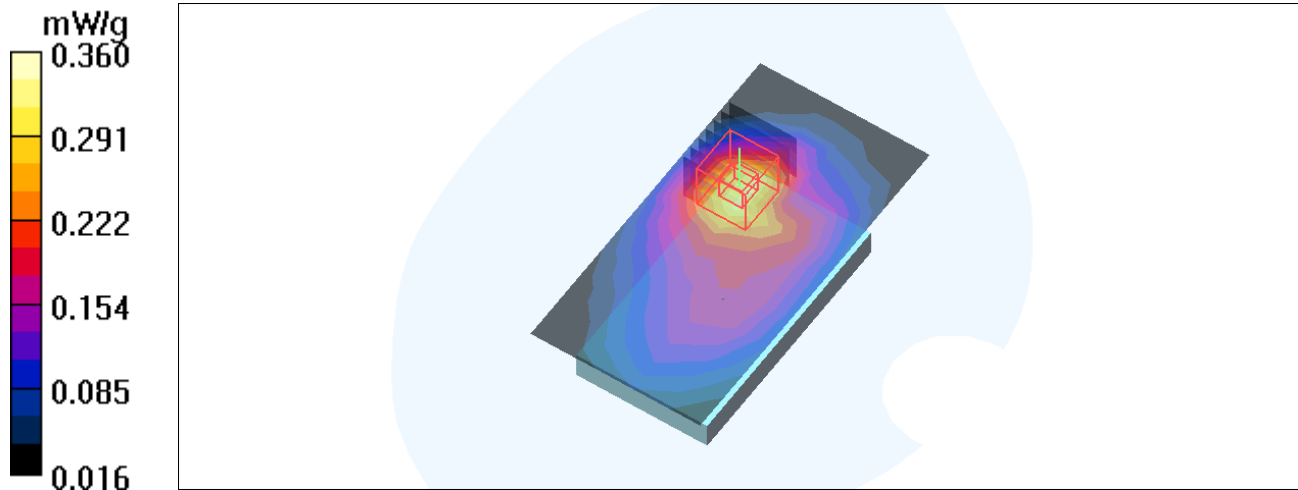

Test Laboratory: Bureau Veritas ADT

M25-Body Front - EGPRS 1900 TS1-Ch661

DUT: GSM/EGPRS Mobile Phone ; Type: EX128

Communication System: PCS 1900 ; Frequency: 1880 MHz ; Duty Cycle: 1:8.3 ; Modulation type: 8PSK
Medium: MSL1900 Medium parameters used: $f = 1880$ MHz; $\sigma = 1.55$ mho/m; $\epsilon_r = 52.3$; $\rho = 1000$ kg/m³
Phantom section: Flat Section ; Separation distance : 15 mm (The Front side of the EUT to the Phantom)

DASY4 Configuration:

- Probe: EX3DV4 - SN3590 ; ConvF(8.61, 8.61, 8.61) ; Calibrated: 2010/3/25
- Sensor-Surface: 3mm (Mechanical Surface Detection)
- Electronics: DAE4 Sn861 ; Calibrated: 2010/1/22
- Phantom: SAM 12 ; Type: SAM V4.0 ; Serial: TP 1202
- Measurement SW: DASY4, V4.7 Build 80 ; Postprocessing SW: SEMCAD, V1.8 Build 186

Mid Channel 661/Area Scan (6x11x1): Measurement grid: dx=15mm, dy=15mm

Maximum value of SAR (measured) = 0.074 mW/g

Mid Channel 661/Zoom Scan (7x7x9)/Cube 0: Measurement grid: dx=5mm, dy=5mm, dz=3mm

Reference Value = 5.57 V/m; Power Drift = -0.179 dB

Peak SAR (extrapolated) = 0.112 W/kg

SAR(1 g) = **0.068 mW/g**; SAR(10 g) = **0.042 mW/g**

Maximum value of SAR (measured) = 0.081 mW/g

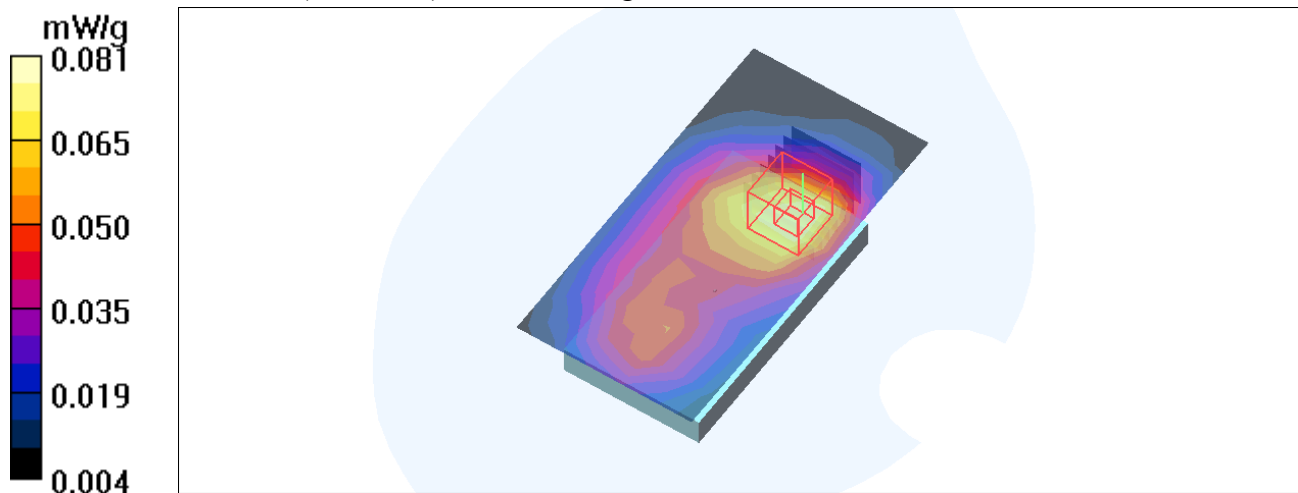

Test Laboratory: Bureau Veritas ADT

M26-Body Bottom - EGPRS 1900 TS1-Ch661

DUT: GSM/EGPRS Mobile Phone ; Type: EX128

Communication System: PCS 1900 ; Frequency: 1880 MHz ; Duty Cycle: 1:8.3 ; Modulation type: 8PSK
Medium: MSL1900 Medium parameters used: $f = 1880$ MHz; $\sigma = 1.55$ mho/m; $\epsilon_r = 52.3$; $\rho = 1000$ kg/m³
Phantom section: Flat Section ; Separation distance : 15 mm (The Bottom side of the EUT to the Phantom)

DASY4 Configuration:

- Probe: EX3DV4 - SN3590 ; ConvF(8.61, 8.61, 8.61) ; Calibrated: 2010/3/25
- Sensor-Surface: 3mm (Mechanical Surface Detection)
- Electronics: DAE4 Sn861 ; Calibrated: 2010/1/22
- Phantom: SAM 12 ; Type: SAM V4.0 ; Serial: TP 1202
- Measurement SW: DASY4, V4.7 Build 80 ; Postprocessing SW: SEMCAD, V1.8 Build 186

Mid Channel 661/Area Scan (6x11x1): Measurement grid: dx=15mm, dy=15mm

Maximum value of SAR (measured) = 0.100 mW/g

Mid Channel 661/Zoom Scan (7x7x9)/Cube 0: Measurement grid: dx=5mm, dy=5mm, dz=3mm

Reference Value = 6.14 V/m; Power Drift = 0.010 dB

Peak SAR (extrapolated) = 0.158 W/kg

SAR(1 g) = **0.094 mW/g**; SAR(10 g) = **0.054 mW/g**

Maximum value of SAR (measured) = 0.115 mW/g

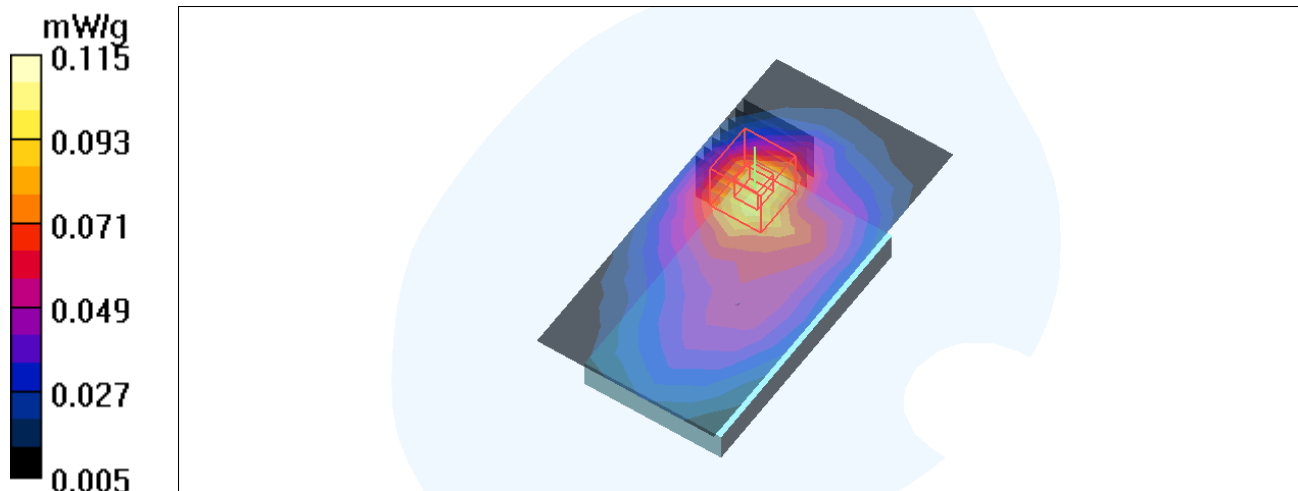

Test Laboratory: Bureau Veritas ADT

M27-Body Front - EGPRS 1900 TS2-Ch661

DUT: GSM/EGPRS Mobile Phone ; Type: EX128

Communication System: PCS 1900 ; Frequency: 1880 MHz ; Duty Cycle: 1:4 ; Modulation type: 8PSK
Medium: MSL1900 Medium parameters used: $f = 1880$ MHz; $\sigma = 1.55$ mho/m; $\epsilon_r = 52.3$; $\rho = 1000$ kg/m³
Phantom section: Flat Section ; Separation distance : 15 mm (The Front side of the EUT to the Phantom)

DASY4 Configuration:

- Probe: EX3DV4 - SN3590 ; ConvF(8.61, 8.61, 8.61) ; Calibrated: 2010/3/25
- Sensor-Surface: 3mm (Mechanical Surface Detection)
- Electronics: DAE4 Sn861 ; Calibrated: 2010/1/22
- Phantom: SAM 12 ; Type: SAM V4.0 ; Serial: TP 1202
- Measurement SW: DASY4, V4.7 Build 80 ; Postprocessing SW: SEMCAD, V1.8 Build 186

Mid Channel 661/Area Scan (6x11x1): Measurement grid: dx=15mm, dy=15mm

Maximum value of SAR (measured) = 0.143 mW/g

Mid Channel 661/Zoom Scan (7x7x9)/Cube 0: Measurement grid: dx=5mm, dy=5mm, dz=3mm

Reference Value = 7.69 V/m; Power Drift = 0.075 dB

Peak SAR (extrapolated) = 0.213 W/kg

SAR(1 g) = **0.134 mW/g**; SAR(10 g) = 0.082 mW/g

Maximum value of SAR (measured) = 0.159 mW/g

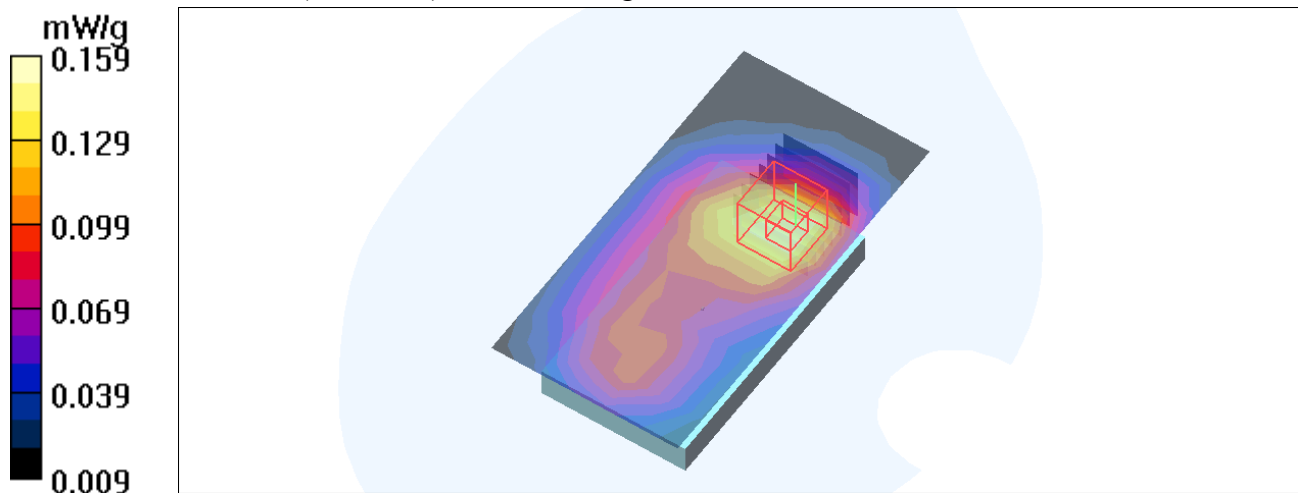

Test Laboratory: Bureau Veritas ADT

M28-Body Bottom - EGPRS 1900 TS2-Ch661

DUT: GSM/EGPRS Mobile Phone ; Type: EX128

Communication System: PCS 1900 ; Frequency: 1880 MHz ; Duty Cycle: 1:4 ; Modulation type: 8PSK
Medium: MSL1900 Medium parameters used: $f = 1880$ MHz; $\sigma = 1.55$ mho/m; $\epsilon_r = 52.3$; $\rho = 1000$ kg/m³
Phantom section: Flat Section ; Separation distance : 15 mm (The Bottom side of the EUT to the Phantom)

DASY4 Configuration:

- Probe: EX3DV4 - SN3590 ; ConvF(8.61, 8.61, 8.61) ; Calibrated: 2010/3/25
- Sensor-Surface: 3mm (Mechanical Surface Detection)
- Electronics: DAE4 Sn861 ; Calibrated: 2010/1/22
- Phantom: SAM 12 ; Type: SAM V4.0 ; Serial: TP 1202
- Measurement SW: DASY4, V4.7 Build 80 ; Postprocessing SW: SEMCAD, V1.8 Build 186

Mid Channel 661/Area Scan (6x11x1): Measurement grid: dx=15mm, dy=15mm
Maximum value of SAR (measured) = 0.195 mW/g

Mid Channel 661/Zoom Scan (7x7x9)/Cube 0: Measurement grid: dx=5mm, dy=5mm, dz=3mm
Reference Value = 8.41 V/m; Power Drift = -0.029 dB
Peak SAR (extrapolated) = 0.301 W/kg
SAR(1 g) = 0.180 mW/g; SAR(10 g) = 0.105 mW/g
Maximum value of SAR (measured) = 0.220 mW/g

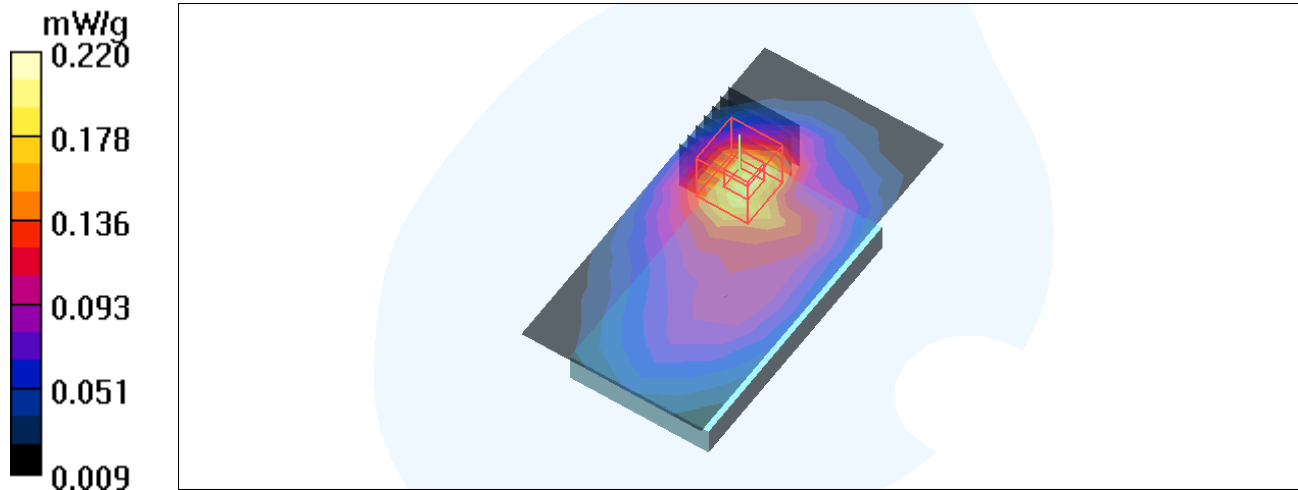

Test Laboratory: Bureau Veritas ADT

M29-Left Head Cheek- GSM 850-Ch190

DUT: GSM/EGPRS Mobile Phone ; Type: EX128

Communication System: GSM 850 ; Frequency: 836.6 MHz ; Duty Cycle: 1:8.3

Medium: HSL835 Medium parameters used: $f = 836.6$ MHz; $\sigma = 0.92$ mho/m; $\epsilon_r = 42.1$; $\rho = 1000$ kg/m³

Phantom section: Left Section ; DUT test position : Cheek ; Modulation type: GMSK

DASY4 Configuration:

- Probe: EX3DV4 - SN3590 ; ConvF(10.25, 10.25, 10.25) ; Calibrated: 2010/3/25
- Sensor-Surface: 3mm (Mechanical Surface Detection)
- Electronics: DAE4 Sn861; Calibrated: 2010/1/22
- Phantom: SAM 12; Type: SAM V4.0; Serial: TP 1202
- Measurement SW: DASY4, V4.7 Build 80; Postprocessing SW: SEMCAD, V1.8 Build 186

Mid Channel 190 /Area Scan (7x11x1): Measurement grid: dx=15mm, dy=15mm

Maximum value of SAR (measured) = 0.730 mW/g

Mid Channel 190 /Zoom Scan (7x7x9)/Cube 0: Measurement grid: dx=5mm, dy=5mm, dz=3mm

Reference Value = 8.25 V/m; Power Drift = 0.037 dB

Peak SAR (extrapolated) = 0.982 W/kg

SAR(1 g) = **0.623** mW/g; SAR(10 g) = **0.418** mW/g

Maximum value of SAR (measured) = 0.728 mW/g

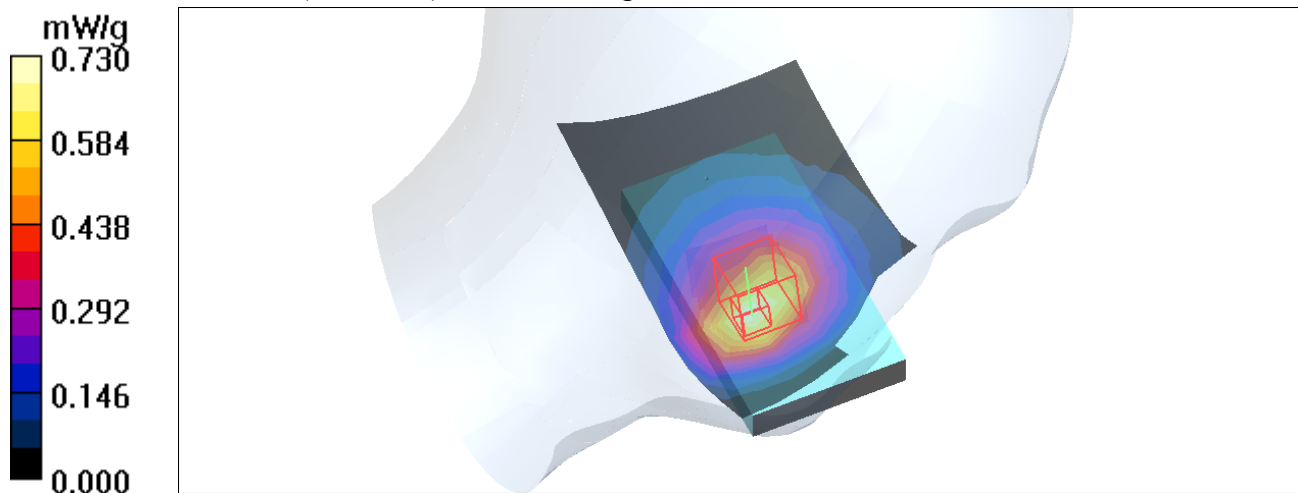

Test Laboratory: Bureau Veritas ADT

M30-Left Head Cheek- GSM 1900-Ch661

DUT: GSM/EGPRS Mobile Phone ; Type: EX128

Communication System: PCS 1900 ; Frequency: 1880 MHz ; Duty Cycle: 1:8.3

Medium: HSL1900 Medium parameters used: $f = 1880$ MHz; $\sigma = 1.42$ mho/m; $\epsilon_r = 40.37$; $\rho = 1000$ kg/m³

Phantom section: Left Section ; DUT test position : Cheek ; Modulation type: GMSK

DASY4 Configuration:

- Probe: EX3DV4 - SN3590 ; ConvF(8.33, 8.33, 8.33) ; Calibrated: 2010/3/25
- Sensor-Surface: 3mm (Mechanical Surface Detection)
- Electronics: DAE4 Sn861; Calibrated: 2010/1/22
- Phantom: SAM 12; Type: SAM V4.0; Serial: TP 1202
- Measurement SW: DASY4, V4.7 Build 80; Postprocessing SW: SEMCAD, V1.8 Build 186

Mid Channel 661 /Area Scan (7x11x1): Measurement grid: dx=15mm, dy=15mm

Maximum value of SAR (measured) = 0.720 mW/g

Mid Channel 661 /Zoom Scan (7x7x9)/Cube 0: Measurement grid: dx=5mm, dy=5mm, dz=3mm

Reference Value = 7.02 V/m; Power Drift = 0.052 dB

Peak SAR (extrapolated) = 1.21 W/kg

SAR(1 g) = 0.718 mW/g; SAR(10 g) = 0.390 mW/g

Maximum value of SAR (measured) = 0.891 mW/g

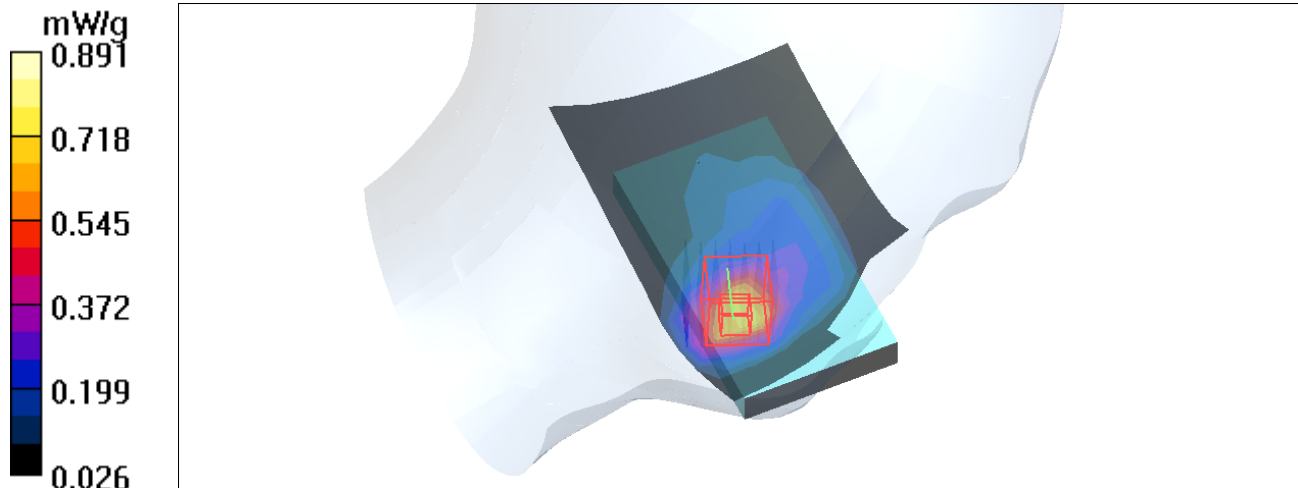

Test Laboratory: Bureau Veritas ADT

M31-Body Bottom - GPRS 850 TS2-Ch190

DUT: GSM/EGPRS Mobile Phone ; Type: EX128

Communication System: GSM 850 ; Frequency: 836.6 MHz ; Duty Cycle: 1:4 ; Modulation type: GMSK
 Medium: MSL835 Medium parameters used: $f = 836.6$ MHz; $\sigma = 0.96$ mho/m; $\epsilon_r = 53.4$; $\rho = 1000$ kg/m³
 Phantom section: Flat Section ; Separation distance : 15 mm (The Bottom side of the EUT to the Phantom)

DASY4 Configuration:

- Probe: EX3DV4 - SN3590 ; ConvF(10.2, 10.2, 10.2) ; Calibrated: 2010/3/25
- Sensor-Surface: 3mm (Mechanical Surface Detection)
- Electronics: DAE4 Sn861 ; Calibrated: 2010/1/22
- Phantom: SAM 12 ; Type: SAM V4.0 ; Serial: TP 1202
- Measurement SW: DASY4, V4.7 Build 80 ; Postprocessing SW: SEMCAD, V1.8 Build 186

Mid Channel 190 /Area Scan (6x11x1): Measurement grid: dx=15mm, dy=15mm

Maximum value of SAR (measured) = 0.794 mW/g

Mid Channel 190 /Zoom Scan (7x7x9)/Cube 0: Measurement grid: dx=5mm, dy=5mm, dz=3mm

Reference Value = 28.7 V/m; Power Drift = 0.023 dB

Peak SAR (extrapolated) = 0.991 W/kg

SAR(1 g) = **0.722 mW/g**; SAR(10 g) = **0.512 mW/g**

Maximum value of SAR (measured) = 0.811 mW/g

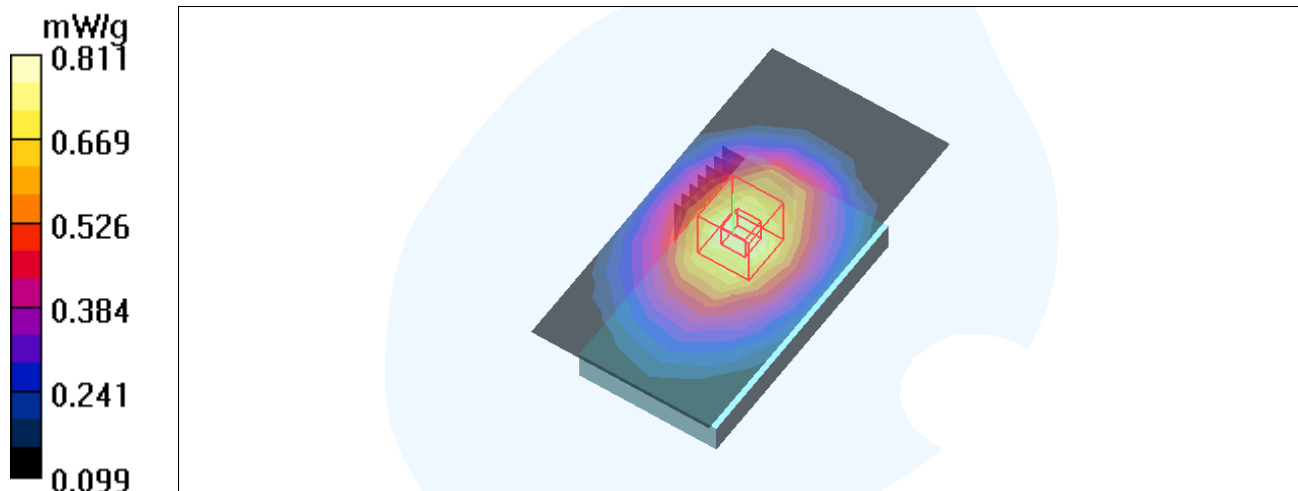

Test Laboratory: Bureau Veritas ADT

M32-Body Bottom- GPRS 1900 TS2-Ch661

DUT: GSM/EGPRS Mobile Phone ; Type: EX128

Communication System: PCS 1900 ; Frequency: 1880 MHz ; Duty Cycle: 1:4 ; Modulation type: GMSK
Medium: MSL1900 Medium parameters used: $f = 1880$ MHz; $\sigma = 1.55$ mho/m; $\epsilon_r = 52.3$; $\rho = 1000$ kg/m³
Phantom section: Flat Section ; Separation distance : 15 mm (The Bottom side of the EUT to the Phantom)

DASY4 Configuration:

- Probe: EX3DV4 - SN3590 ; ConvF(8.61, 8.61, 8.61) ; Calibrated: 2010/3/25
- Sensor-Surface: 3mm (Mechanical Surface Detection)
- Electronics: DAE4 Sn861 ; Calibrated: 2010/1/22
- Phantom: SAM 12 ; Type: SAM V4.0 ; Serial: TP 1202
- Measurement SW: DASY4, V4.7 Build 80 ; Postprocessing SW: SEMCAD, V1.8 Build 186

Mid Channel 661 /Area Scan (6x11x1): Measurement grid: dx=15mm, dy=15mm
Maximum value of SAR (measured) = 0.319 mW/g

Mid Channel 661 /Zoom Scan (7x7x9)/Cube 0: Measurement grid: dx=5mm, dy=5mm, dz=3mm
Reference Value = 11.0 V/m; Power Drift = -0.089 dB
Peak SAR (extrapolated) = 0.489 W/kg
SAR(1 g) = 0.292 mW/g; SAR(10 g) = 0.170 mW/g
Maximum value of SAR (measured) = 0.356 mW/g

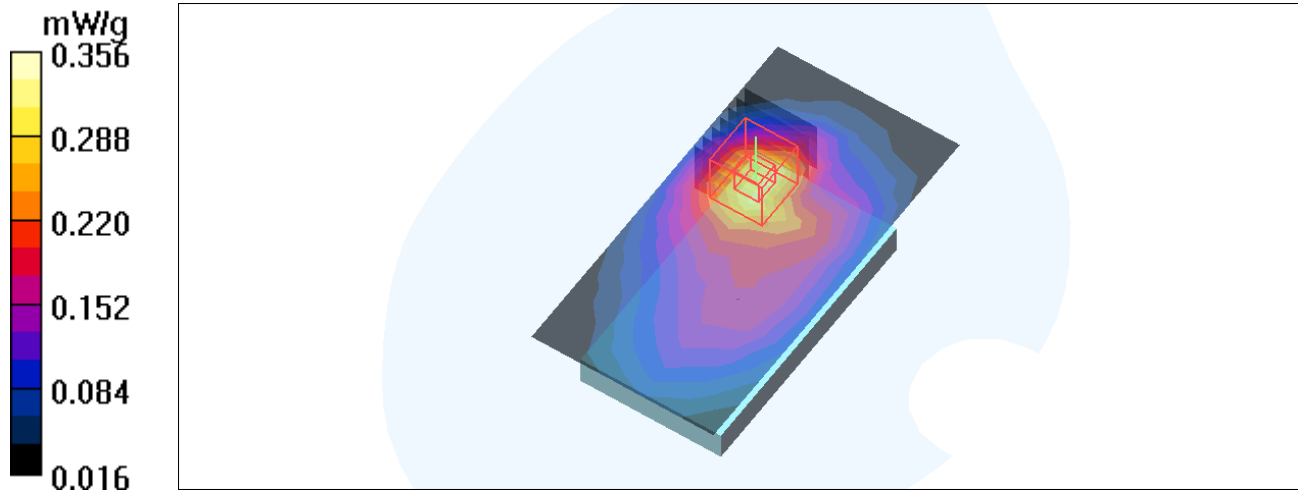

Test Laboratory: Bureau Veritas ADT

System Validation Check-HSL 835MHz

DUT: Dipole 850 MHz ; Type: D835V2 ; Serial: 4d021 ; Test Frequency: 835 MHz

Communication System: CW ; Frequency: 835 MHz; Duty Cycle: 1:1; Modulation type: CW

Medium: HSL835; Medium parameters used: $f = 835$ MHz; $\sigma = 0.91$ mho/m; $\epsilon_r = 42.3$; $\rho = 1000$ kg/m³ ;

Liquid level : 151 mm

Phantom section: Flat Section ; Separation distance : 15 mm (The feetpoint of the dipole to the Phantom)

Air temp. : 23 degrees ; Liquid temp. : 22.7 degrees

DASY4 Configuration:

- Probe: EX3DV4 - SN3590 ; ConvF(10.25, 10.25, 10.25) ; Calibrated: 2010/3/25
- Sensor-Surface: 3mm (Mechanical Surface Detection)
- Electronics: DAE4 Sn861; Calibrated: 2010/1/22
- Phantom: SAM 12; Type: SAM V4.0; Serial: TP 1202
- Measurement SW: DASY4, V4.7 Build 80; Postprocessing SW: SEMCAD, V1.8 Build 186

d=15mm, Pin=250mW /Area Scan (7x9x1): Measurement grid: dx=15mm, dy=15mm

Maximum value of SAR (measured) = 2.58 mW/g

d=15mm, Pin=250mW /Zoom Scan (7x7x7)/Cube 0: Measurement grid: dx=5mm, dy=5mm, dz=5mm

Reference Value = 51.4 V/m; Power Drift = -0.012 dB

Peak SAR (extrapolated) = 3.71 W/kg

SAR(1 g) = 2.43 mW/g; SAR(10 g) = 1.58 mW/g

Maximum value of SAR (measured) = 2.86 mW/g

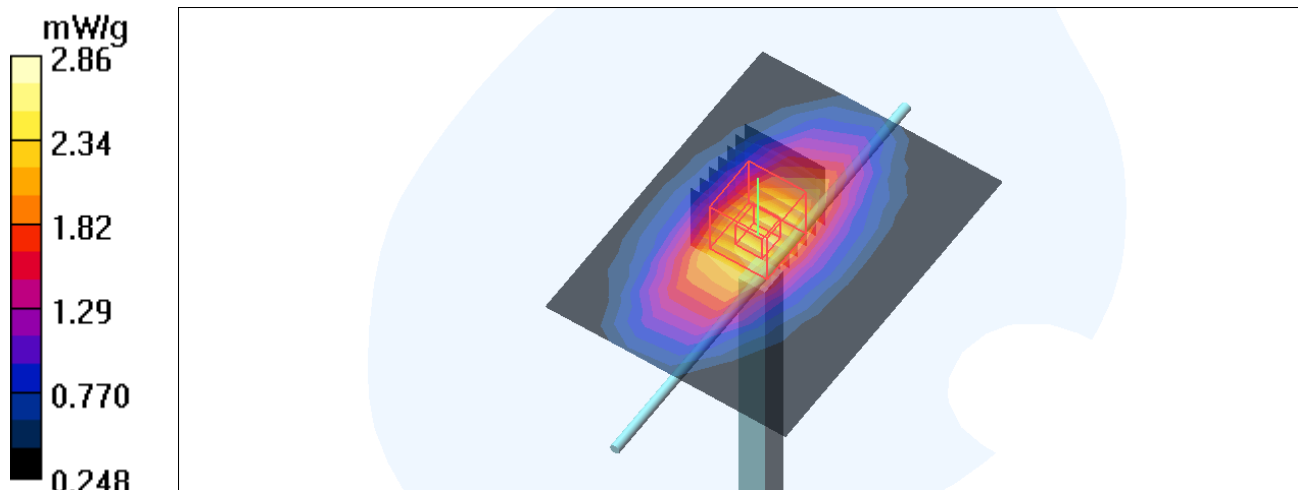

Test Laboratory: Bureau Veritas ADT

System Validation Check-HSL 1900MHz

DUT: Dipole 1900 MHz ; Type: D1900V2 ; Serial: 5d036 ; Test Frequency: 1900 MHz

Communication System: CW ; Frequency: 1900 MHz; Duty Cycle: 1:1; Modulation type: CW
Medium: HSL1900; Medium parameters used: $f = 1900$ MHz; $\sigma = 1.45$ mho/m; $\epsilon_r = 40.33$; $\rho = 1000$ kg/m³ ; Liquid level : 151 mm

Phantom section: Flat Section ; Separation distance : 10 mm (The feetpoint of the dipole to the Phantom) Air temp. : 23 degrees ; Liquid temp. : 22.5 degrees

DASY4 Configuration:

- Probe: EX3DV4 - SN3590 ; ConvF(8.33, 8.33, 8.33) ; Calibrated: 2010/3/25
- Sensor-Surface: 3mm (Mechanical Surface Detection)
- Electronics: DAE4 Sn861; Calibrated: 2010/1/22
- Phantom: SAM 12; Type: SAM V4.0; Serial: TP 1202
- Measurement SW: DASY4, V4.7 Build 80; Postprocessing SW: SEMCAD, V1.8 Build 186

d=10mm, Pin=250mW/Area Scan (7x7x1): Measurement grid: dx=15mm, dy=15mm
Maximum value of SAR (measured) = 13.5 mW/g

d=10mm, Pin=250mW/Zoom Scan (7x7x7)/Cube 0: Measurement grid: dx=5mm, dy=5mm, dz=5mm

Reference Value = 99.7 V/m; Power Drift = -0.021 dB

Peak SAR (extrapolated) = 20.6 W/kg

SAR(1 g) = 10.4 mW/g; SAR(10 g) = 5.19 mW/g

Maximum value of SAR (measured) = 13.4 mW/g

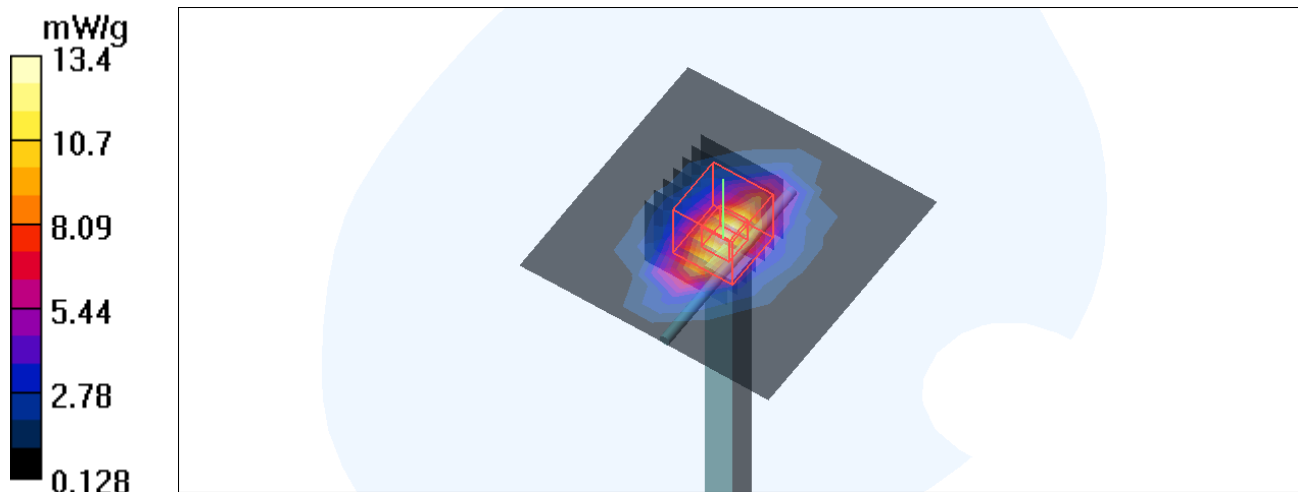

Test Laboratory: Bureau Veritas ADT

System Validation Check-MSL 835MHz

DUT: Dipole 850 MHz ; Type: D835V2 ; Serial: 4d021 ; Test Frequency: 835 MHz

Communication System: CW ; Frequency: 835 MHz; Duty Cycle: 1:1; Modulation type: CW

Medium: MSL835; Medium parameters used: $f = 835$ MHz; $\sigma = 0.95$ mho/m; $\epsilon_r = 53.5$; $\rho = 1000$ kg/m³ ;

Liquid level : 152 mm

Phantom section: Flat Section ; Separation distance : 15 mm (The feetpoint of the dipole to the Phantom) Air temp. : 23 degrees ; Liquid temp. : 22.8 degrees

DASY4 Configuration:

- Probe: EX3DV4 - SN3590 ; ConvF(10.2, 10.2, 10.2) ; Calibrated: 2010/3/25
- Sensor-Surface: 3mm (Mechanical Surface Detection)
- Electronics: DAE4 Sn861; Calibrated: 2010/1/22
- Phantom: SAM 12; Type: SAM V4.0; Serial: TP 1202
- Measurement SW: DASY4, V4.7 Build 80; Postprocessing SW: SEMCAD, V1.8 Build 186

d=15mm, Pin=250mW/Area Scan (7x9x1): Measurement grid: dx=15mm, dy=15mm
Maximum value of SAR (measured) = 2.76 mW/g**d=15mm, Pin=250mW/Zoom Scan (7x7x7)/Cube 0:** Measurement grid: dx=5mm, dy=5mm, dz=5mm

Reference Value = 53.3 V/m; Power Drift = -0.007 dB

Peak SAR (extrapolated) = 4.02 W/kg

SAR(1 g) = 2.66 mW/g; SAR(10 g) = 1.73 mW/g

Maximum value of SAR (measured) = 3.13 mW/g

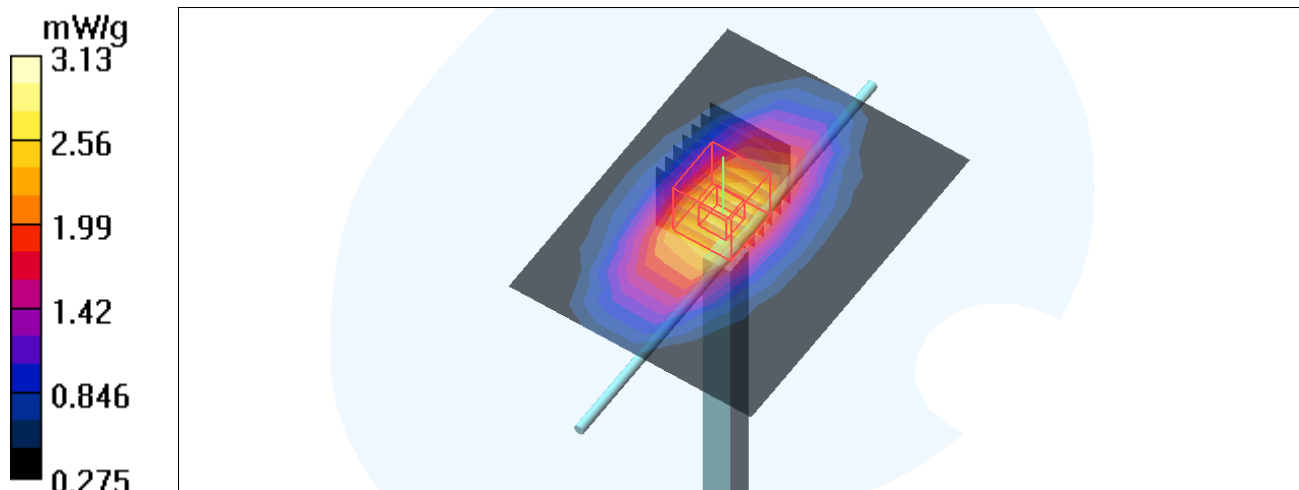

Test Laboratory: Bureau Veritas ADT

System Validation Check-MSL 1900MHz

DUT: Dipole 1900 MHz ; Type: D1900V2 ; Serial: 5d036 ; Test Frequency: 1900 MHz

Communication System: CW ; Frequency: 1900 MHz; Duty Cycle: 1:1; Modulation type: CW
 Medium: MSL1900; Medium parameters used: $f = 1900$ MHz; $\sigma = 1.57$ mho/m; $\epsilon_r = 51.8$; $\rho = 1000$ kg/m³ ; Liquid level : 151 mm

Phantom section: Flat Section ; Separation distance : 10 mm (The feetpoint of the dipole to the Phantom) Air temp. : 22.9 degrees ; Liquid temp. : 22.6 degrees

DASY4 Configuration:

- Probe: EX3DV4 - SN3590 ; ConvF(8.61, 8.61, 8.61) ; Calibrated: 2010/3/25
- Sensor-Surface: 3mm (Mechanical Surface Detection)
- Electronics: DAE4 Sn861; Calibrated: 2010/1/22
- Phantom: SAM 12; Type: SAM V4.0; Serial: TP 1202
- Measurement SW: DASY4, V4.7 Build 80; Postprocessing SW: SEMCAD, V1.8 Build 186

d=10mm, Pin=250mW/Area Scan (7x7x1): Measurement grid: dx=15mm, dy=15mm
 Maximum value of SAR (measured) = 13.6 mW/g

d=10mm, Pin=250mW/Zoom Scan (7x7x7)/Cube 0: Measurement grid: dx=5mm, dy=5mm, dz=5mm

Reference Value = 89.7 V/m; Power Drift = -0.016 dB

Peak SAR (extrapolated) = 19.8 W/kg

SAR(1 g) = **10.5 mW/g**; SAR(10 g) = 5.37 mW/g

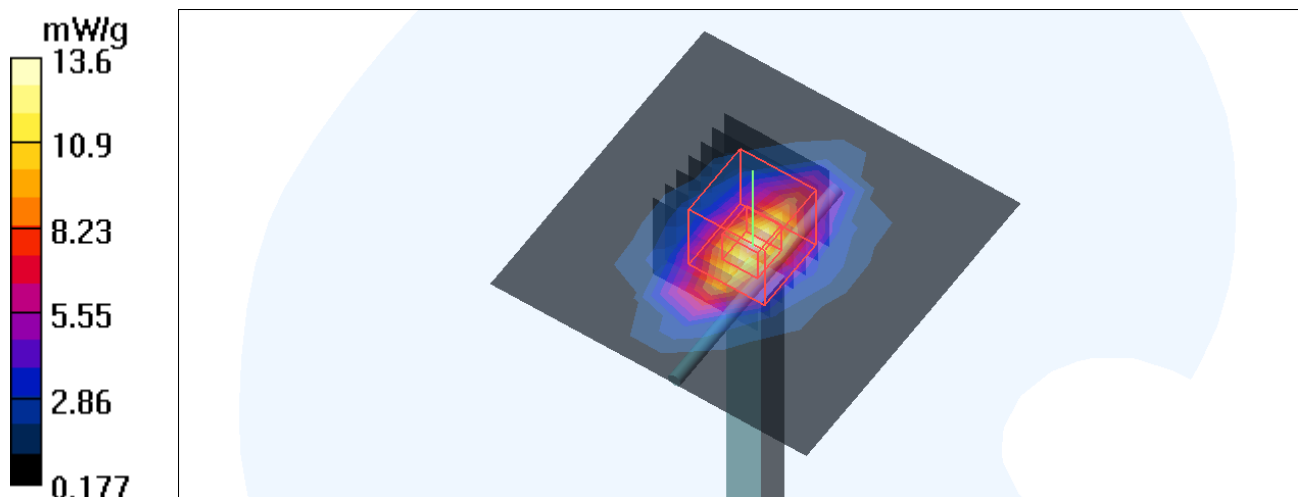

APPENDIX A: TEST DATA

Liquid Level Photo

Tissue HSL 850MHz D=151mm

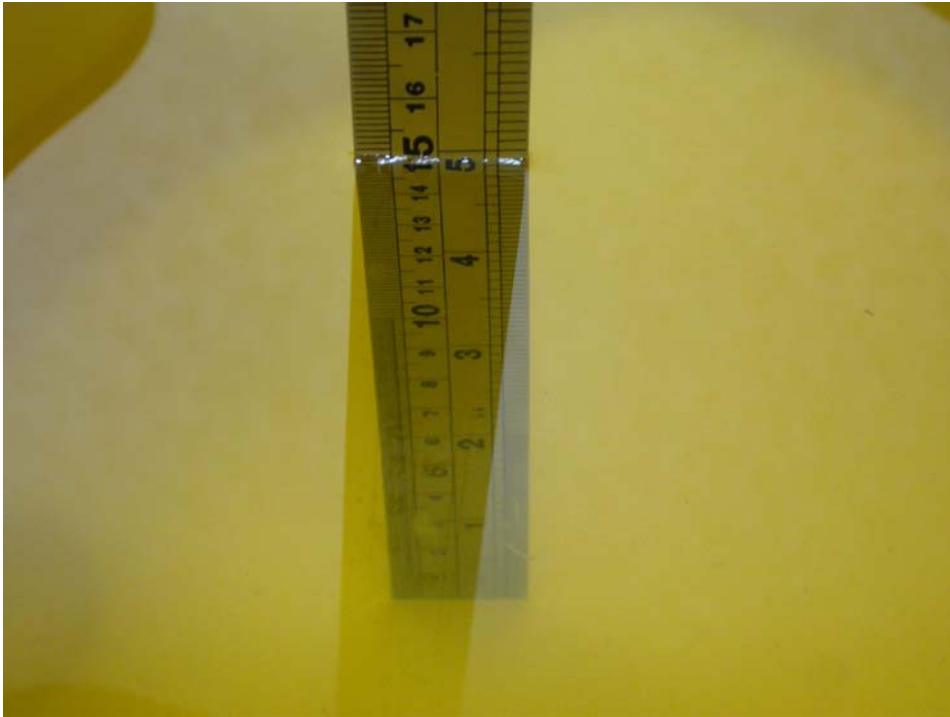

Tissue MSL 850MHz D=152mm



Tissue HSL 1900MHz D=151mm



Tissue MSL 1900MHz D=150mm



Test Laboratory: Bureau Veritas ADT

M01 Left Head Cheek GSM850 Ch190 SIM 1

DUT: GSM/EGPRS Mobile Phone ; Type: EX122

Communication System: GSM 850 ; Frequency: 836.6 MHz ; Duty Cycle: 1:8.3; Modulation type: GMSK

Medium: HSL835 Medium parameters used: $f = 836.6$ MHz; $\sigma = 0.92$ mho/m; $\epsilon_r = 42.1$; $\rho = 1000$ kg/m³

Phantom section: Left Section ; DUT test position : Cheek ;

DASY4 Configuration:

- Probe: EX3DV4 - SN3590 ; ConvF(10.25, 10.25, 10.25) ; Calibrated: 2010/3/25
- Sensor-Surface: 3mm (Mechanical Surface Detection)
- Electronics: DAE4 Sn861; Calibrated: 2010/1/22
- Phantom: SAM 12; Type: SAM V4.0; Serial: TP 1202
- Measurement SW: DASY4, V4.7 Build 80; Postprocessing SW: SEMCAD, V1.8 Build 172

Mid Channel 190 Cheek/Area Scan (7x11x1): Measurement grid: dx=15mm, dy=15mm
Maximum value of SAR (measured) = 0.805 mW/g**Mid Channel 190 Cheek/Zoom Scan (7x7x9)/Cube 0:** Measurement grid: dx=5mm, dy=5mm, dz=3mm

Reference Value = 7.99 V/m; Power Drift = -0.144 dB

Peak SAR (extrapolated) = 1.00 W/kg

SAR(1 g) = 0.629 mW/g; SAR(10 g) = 0.418 mW/g

Maximum value of SAR (measured) = 0.736 mW/g

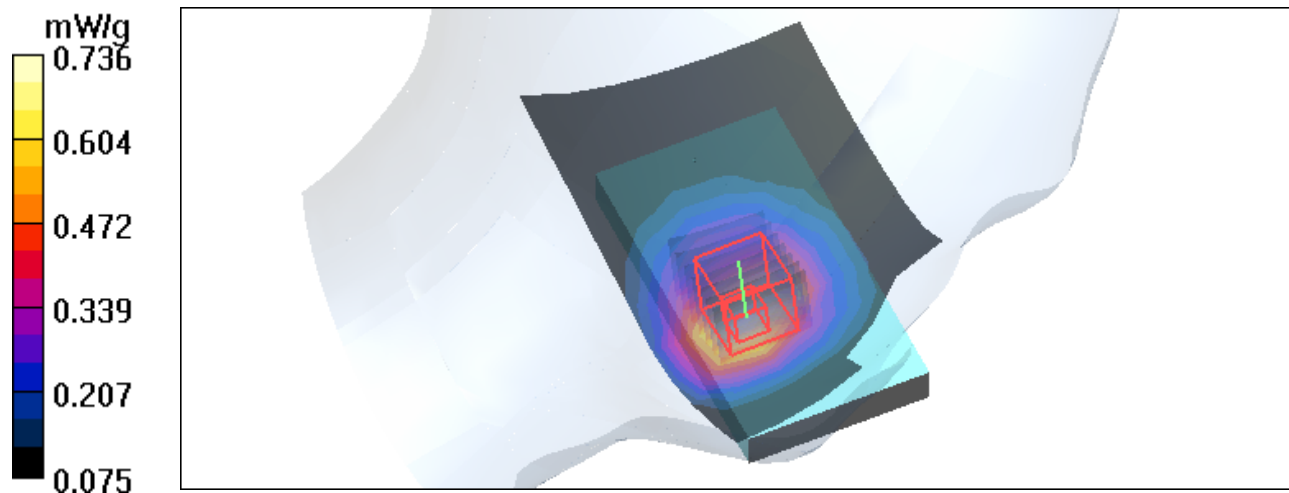

Test Laboratory: Bureau Veritas ADT

M02 Left Head Cheek GSM1900 Ch661 SIM 1

DUT: GSM/EGPRS Mobile Phone ; Type: EX122

Communication System: PCS 1900 ; Frequency: 1880 MHz ; Duty Cycle: 1:8.3; Modulation type: GMSK

Medium: HSL1900 Medium parameters used: $f = 1880$ MHz; $\sigma = 1.39$ mho/m; $\epsilon_r = 40.5$; $\rho = 1000$ kg/m³

Phantom section: Left Section ; DUT test position : Cheek ;

DASY4 Configuration:

- Probe: EX3DV4 - SN3590 ; ConvF(8.33, 8.33, 8.33) ; Calibrated: 2010/3/25
- Sensor-Surface: 3mm (Mechanical Surface Detection)
- Electronics: DAE4 Sn861; Calibrated: 2010/1/22
- Phantom: SAM 12; Type: SAM V4.0; Serial: TP 1202
- Measurement SW: DASY4, V4.7 Build 80; Postprocessing SW: SEMCAD, V1.8 Build 172

Mid Channel 661 Cheek/Area Scan (7x11x1): Measurement grid: dx=15mm, dy=15mm
Maximum value of SAR (measured) = 0.682 mW/g**Mid Channel 661 Cheek/Zoom Scan (7x7x9)/Cube 0:** Measurement grid: dx=5mm, dy=5mm, dz=3mm

Reference Value = 5.49 V/m; Power Drift = 0.018 dB

Peak SAR (extrapolated) = 1.20 W/kg

SAR(1 g) = 0.714 mW/g; SAR(10 g) = 0.391 mW/g

Maximum value of SAR (measured) = 0.861 mW/g

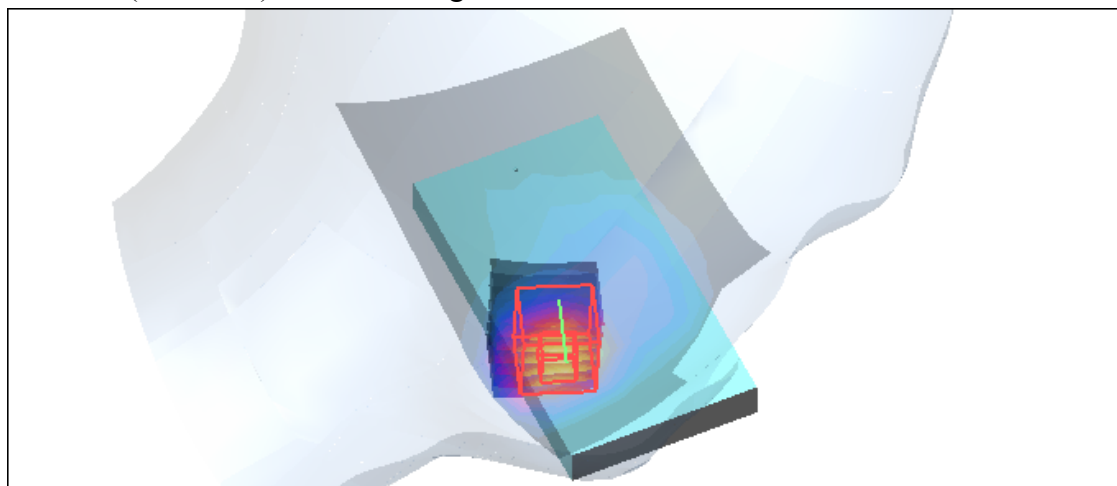
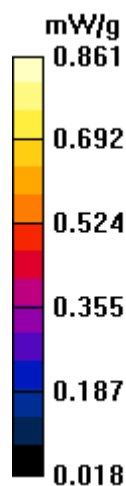

Test Laboratory: Bureau Veritas ADT

M03 Body Bottom GPRS 850 TS2 Ch190 SIM1

DUT: GSM/EGPRS Mobile Phone ; Type: EX122

Communication System: GSM 850 ; Frequency: 836.6 MHz ; Duty Cycle: 1:4 ; Modulation type: GMSK
Medium: MSL835 Medium parameters used: $f = 836.6$ MHz; $\sigma = 0.95$ mho/m; $\epsilon_r = 53.4$; $\rho = 1000$ kg/m³
Phantom section: Flat Section ; Separation distance : 15 mm (The Bottom side of the EUT to the Phantom)

DASY4 Configuration:

- Probe: EX3DV4 - SN3590 ; ConvF(10.2, 10.2, 10.2) ; Calibrated: 2010/3/25
- Sensor-Surface: 3mm (Mechanical Surface Detection)
- Electronics: DAE4 Sn861; Calibrated: 2010/1/22
- Phantom: SAM 12; Type: SAM V4.0; Serial: TP 1202
- Measurement SW: DASY4, V4.7 Build 80; Postprocessing SW: SEMCAD, V1.8 Build 172

Mid Channel 190/Area Scan (6x11x1): Measurement grid: dx=15mm, dy=15mm
Maximum value of SAR (measured) = 0.808 mW/g

Mid Channel 190/Zoom Scan (7x7x9)/Cube 0: Measurement grid: dx=5mm, dy=5mm, dz=3mm
Reference Value = 27.9 V/m; Power Drift = -0.181 dB
Peak SAR (extrapolated) = 1.07 W/kg
SAR(1 g) = 0.725 mW/g; SAR(10 g) = 0.511 mW/g
Maximum value of SAR (measured) = 0.814 mW/g

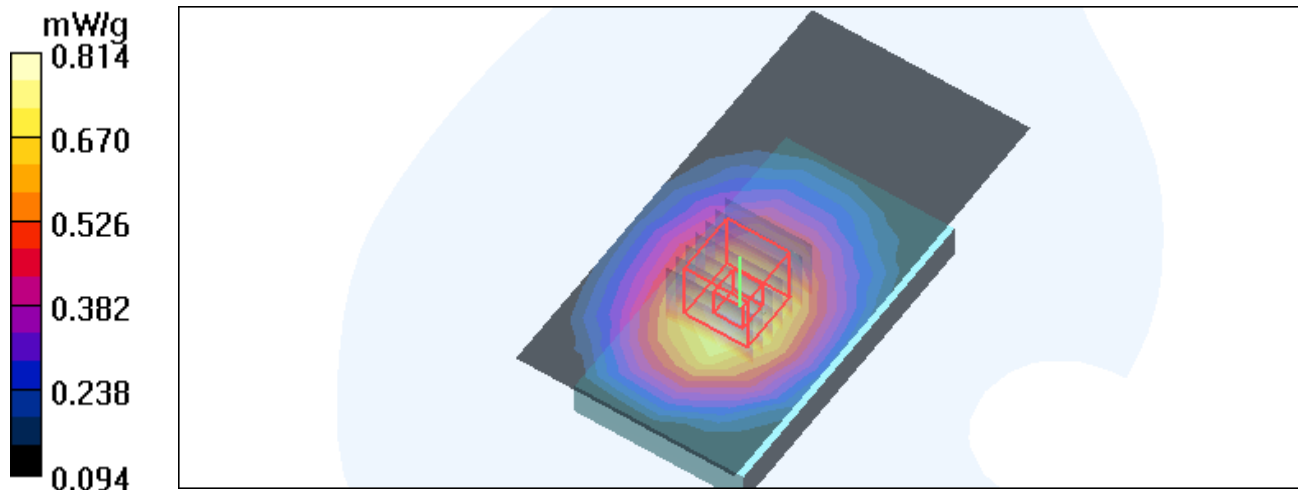

Test Laboratory: Bureau Veritas ADT

M04 Body Bottom GPRS1900 TS2 Ch661 SIM1

DUT: GSM/EGPRS Mobile Phone ; Type: EX122

Communication System: PCS 1900 ; Frequency: 1880 MHz ; Duty Cycle: 1:4 ; Modulation type: GMSK
Medium: MSL1900 Medium parameters used: $f = 1880$ MHz; $\sigma = 1.53$ mho/m; $\epsilon_r = 54.6$; $\rho = 1000$ kg/m³
Phantom section: Flat Section ; Separation distance : 15 mm (The Bottom side of the EUT to the Phantom)

DASY4 Configuration:

- Probe: EX3DV4 - SN3590 ; ConvF(8.61, 8.61, 8.61) ; Calibrated: 2010/3/25
- Sensor-Surface: 3mm (Mechanical Surface Detection)
- Electronics: DAE4 Sn861; Calibrated: 2010/1/22
- Phantom: SAM 12; Type: SAM V4.0; Serial: TP 1202
- Measurement SW: DASY4, V4.7 Build 80; Postprocessing SW: SEMCAD, V1.8 Build 172

Mid Channel 661/Area Scan (6x11x1): Measurement grid: dx=15mm, dy=15mm
Maximum value of SAR (measured) = 0.343 mW/g

Mid Channel 661/Zoom Scan (7x7x9)/Cube 0: Measurement grid: dx=5mm, dy=5mm, dz=3mm
Reference Value = 9.62 V/m; Power Drift = -0.169 dB
Peak SAR (extrapolated) = 0.483 W/kg
SAR(1 g) = 0.283 mW/g; SAR(10 g) = 0.168 mW/g
Maximum value of SAR (measured) = 0.352 mW/g

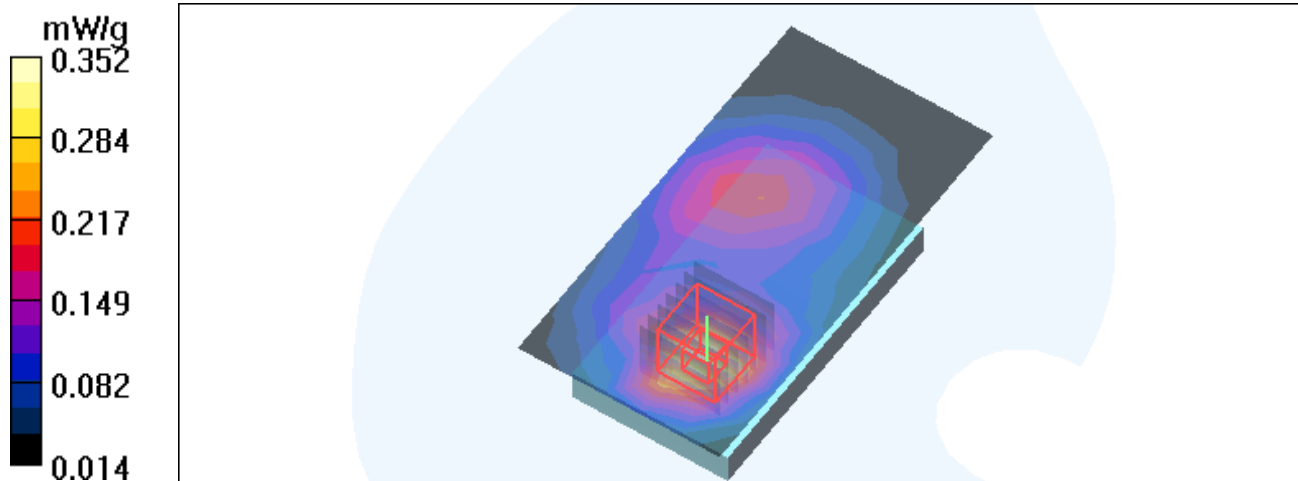

Test Laboratory: Bureau Veritas ADT

System Validation Check HSL 835MHz

DUT: Dipole 850 MHz ; Type: D835V2 ; Serial: 4d021 ; Test Frequency: 835 MHz

Communication System: CW ; Frequency: 835 MHz; Duty Cycle: 1:1; Modulation type: CW
Medium: HSL835; Medium parameters used: $f = 835$ MHz; $\sigma = 0.92$ mho/m; $\epsilon_r = 42.2$; $\rho = 1000$ kg/m³ ;
Liquid level : 151 mm
Phantom section: Flat Section ; Separation distance : 15 mm (The feetpoint of the dipole to the Phantom)
Air temp. : 23 degrees ; Liquid temp. : 22.7 degrees

DASY4 Configuration:

- Probe: EX3DV4 - SN3590 ; ConvF(10.25, 10.25, 10.25) ; Calibrated: 2010/3/25
- Sensor-Surface: 3mm (Mechanical Surface Detection)
- Electronics: DAE4 Sn861; Calibrated: 2010/1/22
- Phantom: SAM 12; Type: SAM V4.0; Serial: TP 1202
- Measurement SW: DASY4, V4.7 Build 80; Postprocessing SW: SEMCAD, V1.8 Build 172

d=15mm, Pin=250mW/Area Scan (7x9x1): Measurement grid: dx=15mm, dy=15mm

Maximum value of SAR (measured) = 2.40 mW/g

d=15mm, Pin=250mW/Zoom Scan (7x7x7) (7x7x7)/Cube 0: Measurement grid: dx=5mm, dy=5mm, dz=5mm

Reference Value = 55.4 V/m; Power Drift = -0.147 dB

Peak SAR (extrapolated) = 3.58 W/kg

SAR(1 g) = 2.34 mW/g; SAR(10 g) = 1.53 mW/g

Maximum value of SAR (measured) = 2.76 mW/g

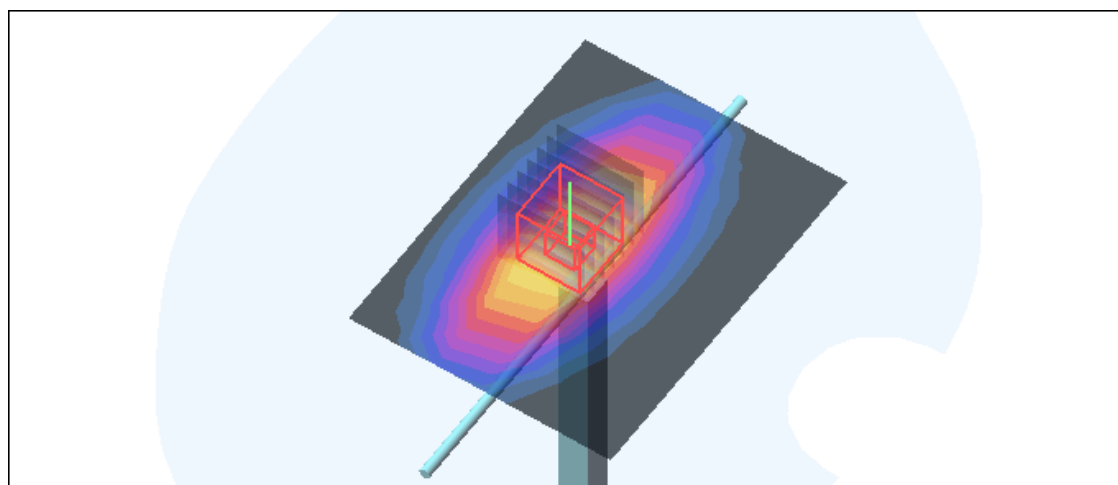
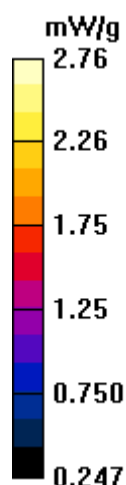

Test Laboratory: Bureau Veritas ADT

System Validation Check HSL 1900MHz

DUT: Dipole 1900 MHz ; Type: D1900V2

Communication System: CW ; Frequency: 1900 MHz; Duty Cycle: 1:1; Modulation type: CW
 Medium: HSL1900; Medium parameters used: $f = 1900$ MHz; $\sigma = 1.39$ mho/m; $\epsilon_r = 40.4$; $\rho = 1000$ kg/m³ ;
 Liquid level : 152 mm
 Phantom section: Flat Section ; Separation distance : 10 mm (The feetpoint of the dipole to the Phantom)
 Air temp. : 23 degrees ; Liquid temp. : 22.5 degrees

DASY4 Configuration:

- Probe: EX3DV4 - SN3590 ; ConvF(8.33, 8.33, 8.33) ; Calibrated: 2010/3/25
- Sensor-Surface: 3mm (Mechanical Surface Detection)
- Electronics: DAE4 Sn861 ; Calibrated: 2010/1/22
- Phantom: SAM 12 ; Type: SAM V4.0 ; Serial: TP 1202
- Measurement SW: DASY4, V4.7 Build 80 ; Postprocessing SW: SEMCAD, V1.8 Build 172

d=10mm, Pin=250mW/Area Scan (7x7x1): Measurement grid: dx=15mm, dy=15mm
 Maximum value of SAR (measured) = 13.2 mW/g

d=10mm, Pin=250mW/Zoom Scan (7x7x7) (7x7x7)/Cube 0: Measurement grid: dx=5mm, dy=5mm, dz=5mm

Reference Value = 96.0 V/m; Power Drift = 0.002 dB

Peak SAR (extrapolated) = 20.6 W/kg

SAR(1 g) = 10.5 mW/g; SAR(10 g) = 5.29 mW/g

Maximum value of SAR (measured) = 13.4 mW/g

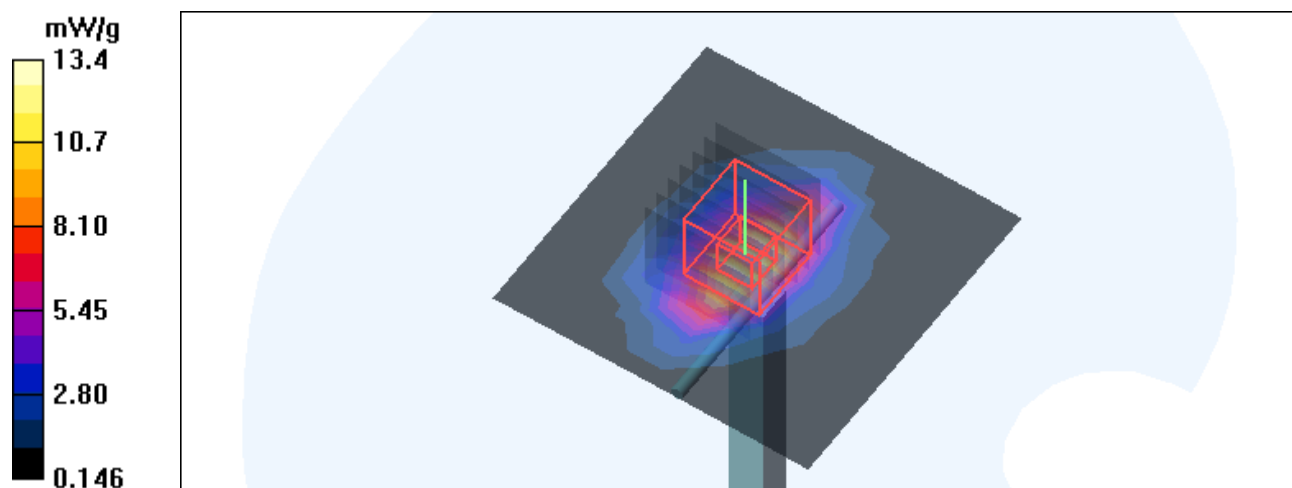

Test Laboratory: Bureau Veritas ADT

System Validation Check MSL 835MHz

DUT: Dipole 850 MHz ; Type: D835V2

Communication System: CW ; Frequency: 835 MHz; Duty Cycle: 1:1; Modulation type: CW
 Medium: MSL835; Medium parameters used: $f = 835$ MHz; $\sigma = 0.94$ mho/m; $\epsilon_r = 53.5$; $\rho = 1000$ kg/m³ ;
 Liquid level : 151 mm
 Phantom section: Flat Section ; Separation distance : 15 mm (The feetpoint of the dipole to the Phantom)
 Air temp. : 23 degrees ; Liquid temp. : 22.8 degrees

DASY4 Configuration:

- Probe: EX3DV4 - SN3590 ; ConvF(10.2, 10.2, 10.2) ; Calibrated: 2010/3/25
- Sensor-Surface: 3mm (Mechanical Surface Detection)
- Electronics: DAE4 Sn861 ; Calibrated: 2010/1/22
- Phantom: SAM 12 ; Type: SAM V4.0 ; Serial: TP 1202
- Measurement SW: DASY4, V4.7 Build 80 ; Postprocessing SW: SEMCAD, V1.8 Build 172

d=15mm, Pin=250mW/Area Scan (7x9x1): Measurement grid: dx=15mm, dy=15mm
 Maximum value of SAR (measured) = 2.48 mW/g

d=15mm, Pin=250mW/Zoom Scan (7x7x7) (7x7x7)/Cube 0: Measurement grid: dx=5mm, dy=5mm, dz=5mm
 Reference Value = 53.7 V/m; Power Drift = -0.139 dB
 Peak SAR (extrapolated) = 3.68 W/kg
SAR(1 g) = 2.43 mW/g; SAR(10 g) = 1.58 mW/g
 Maximum value of SAR (measured) = 2.85 mW/g

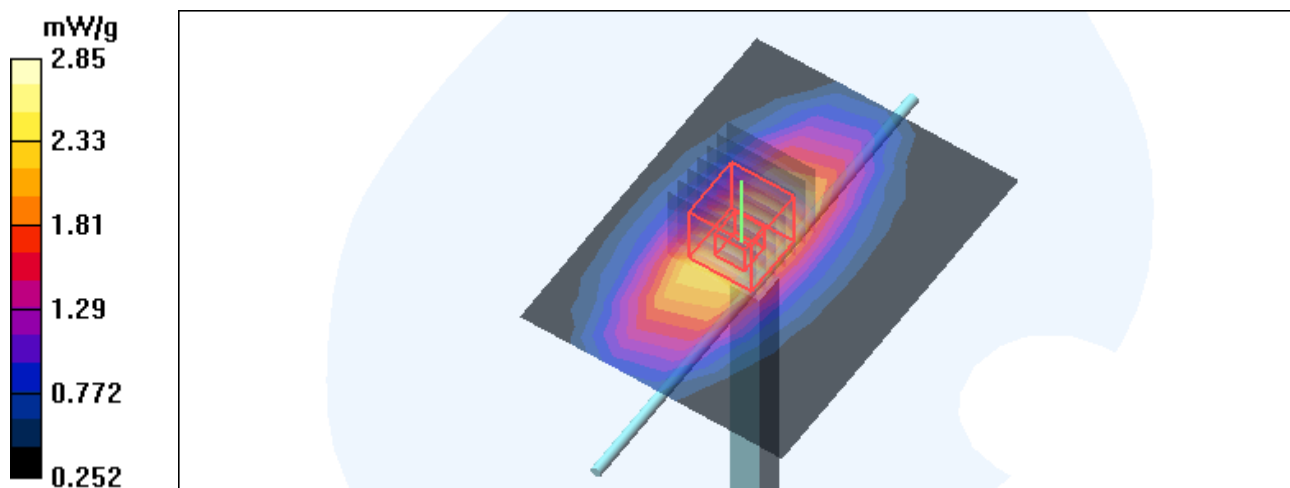

Test Laboratory: Bureau Veritas ADT

System Validation Check MSL 1900MHz

DUT: Dipole 1900 MHz ; Type: D1900V2

Communication System: CW ; Frequency: 1900 MHz; Duty Cycle: 1:1; Modulation type: CW
Medium: MSL1900; Medium parameters used: $f = 1900$ MHz; $\sigma = 1.54$ mho/m; $\epsilon_r = 54.5$; $\rho = 1000$ kg/m³ ; Liquid level : 150 mm
Phantom section: Flat Section ; Separation distance : 10 mm (The feetpoint of the dipole to the Phantom) Air temp. : 22.9 degrees ; Liquid temp. : 22.6 degrees

DASY4 Configuration:

- Probe: EX3DV4 - SN3590 ; ConvF(8.61, 8.61, 8.61) ; Calibrated: 2010/3/25
- Sensor-Surface: 3mm (Mechanical Surface Detection)
- Electronics: DAE4 Sn861 ; Calibrated: 2010/1/22
- Phantom: SAM 12 ; Type: SAM V4.0 ; Serial: TP 1202
- Measurement SW: DASY4, V4.7 Build 80 ; Postprocessing SW: SEMCAD, V1.8 Build 172

d=10mm, Pin=250mW/Area Scan (7x7x1): Measurement grid: dx=15mm, dy=15mm
Maximum value of SAR (measured) = 11.2 mW/g

d=10mm, Pin=250mW/Zoom Scan (7x7x7) (7x7x7)/Cube 0: Measurement grid: dx=5mm, dy=5mm, dz=5mm

Reference Value = 85.1 V/m; Power Drift = 0.071 dB

Peak SAR (extrapolated) = 17.8 W/kg

SAR(1 g) = 9.68 mW/g; SAR(10 g) = 5.16 mW/g

Maximum value of SAR (measured) = 12.1 mW/g

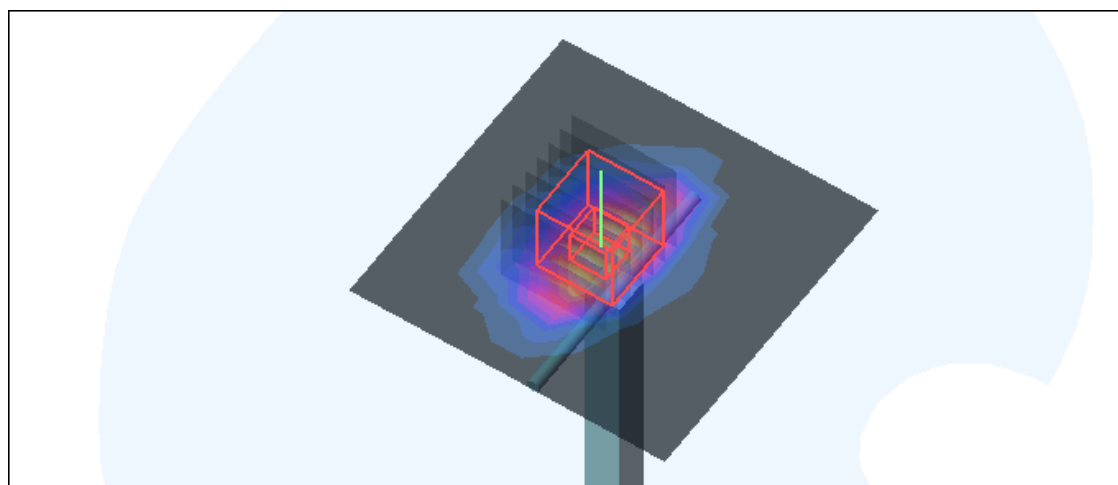
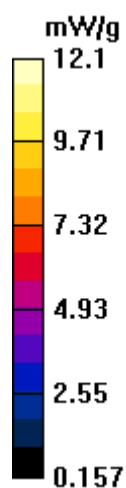

APPENDIX B: BV ADT SAR MEASUREMENT SYSTEM



APPENDIX C: PHOTOGRAPHS OF SYSTEM VALIDATION

