

FCC RF Test Report

APPLICANT : Motorola Inc.
EQUIPMENT : Smart phone
BRAND NAME : MOTOROLA
MODEL NAME : XT502
MARKETING NAME : Quench XT3 / Quench XT5
FCC ID : IHDP56LH1
STANDARD : FCC Part 15 Subpart C §15.247
CLASSIFICATION : Digital Spread Spectrum (DSS)

The product was received on Apr. 28, 2009 and completely tested on Jun. 25, 2010. We, SPORTON INTERNATIONAL INC., would like to declare that the tested sample has been evaluated in accordance with the procedures given in ANSI C63.4-2003 and shown the compliance with the applicable technical standards.

The test results in this report apply exclusively to the tested model / sample. Without written approval of SPORTON INTERNATIONAL INC., the test report shall not be reproduced except in full.

Reviewed by:

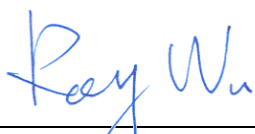

Roy Wu / Manager



SPORTON INTERNATIONAL INC.

No. 52, Hwa Ya 1st Rd., Hwa Ya Technology Park, Kwei-Shan Hsiang, Tao Yuan Hsien, Taiwan, R.O.C.



TABLE OF CONTENTS

REVISION HISTORY 3

SUMMARY OF TEST RESULT 4

1 GENERAL DESCRIPTION 5

 1.1 Applicant 5

 1.2 Manufacturer 5

 1.3 Feature of Equipment Under Test 5

 1.4 Testing Site 7

 1.5 Applied Standards 7

 1.6 Ancillary Equipment List 7

2 TEST CONFIGURATION OF EQUIPMENT UNDER TEST 8

 2.1 RF Output Power 8

 2.2 Test Mode 9

 2.3 Connection Diagram of Test System 10

 2.4 RF Utility 10

3 TEST RESULT 11

 3.1 Number of Channel Measurement 11

 3.2 20dB Bandwidth Measurement 13

 3.3 Hopping Channel Separation Measurement 20

 3.4 Dwell Time Measurement 23

 3.5 Peak Output Power Measurement 25

 3.6 Band Edges Measurement 28

 3.7 Spurious Emission Measurement 38

 3.8 AC Conducted Emission Measurement 42

 3.9 Radiated Emission Measurement 46

 3.10 Antenna Requirements 55

4 LIST OF MEASURING EQUIPMENT 56

5 UNCERTAINTY OF EVALUATION 57

6 CERTIFICATION OF TAF ACCREDITATION 58

APPENDIX A. PHOTOGRAPHS OF EUT

APPENDIX B. SETUP PHOTOGRAPHS

**SUMMARY OF TEST RESULT**

Report Section	FCC Rule	IC Rule	Description	Limit	Result	Remark
3.1	15.247(a)(1)	A8.4(2)	Number of Channels	≥ 15Chs	Pass	-
3.2	15.247(a)(1)	A8.1(a)	20dB Bandwidth	NA	Pass	-
3.3	15.247(a)(1)	A8.1(b)	Channel Separation	≥ 2/3 of 20dB BW	Pass	-
3.4	15.247(a)(1)	A8.1(d)	Dwell Time of Each Channel	≤ 0.4sec in 31.6sec period	Pass	-
3.5	15.247(b)(1)	A8.1(b)	Peak Output Power	≤ 1W	Pass	-
3.6	15.247(d)	A8.5	Frequency Band Edges	≤ 20dBc	Pass	-
3.7	15.247(d)	A8.5	Spurious Emission	< 20 dBc	Pass	-
3.8	15.207	Gen 7.2.2	AC Conducted Emission	15.207(a)	Pass	Under limit 20.0 dB at 0.534 MHz
3.9	15.247(d)	A8.5	Transmitter Radiated Emission	15.209(a) & 15.247(d)	Pass	Under limit 8.73 dB at 2483.5 MHz
3.10	15.203 & 15.247(b)	A8.4	Antenna Requirement	N/A	Pass	-



1 General Description

1.1 Applicant

Motorola Inc.

600 N. U.S. Highway 45 Libertyville, IL 60048-5343

1.2 Manufacturer

Chi Mei Communication Systems, Inc.

No. 4, Mingsheng Street, Tucheng City, Taipei County 23678, Taiwan

1.3 Feature of Equipment Under Test

Product Feature & Specification	
Equipment	Smart phone
Brand Name	MOTOROLA
Model Name	XT502
Marketing Name	Quench XT3 / Quench XT5
FCC ID	IHDP56LH1
Tx/Rx Frequency Range	2400 MHz ~ 2483.5 MHz
Number of Channels	79
Carrier Frequency of Each Channel	2402+n*1 MHz; n=0~78
Channel Spacing	1 MHz
Maximum Output Power to Antenna	Bluetooth (1Mbps) : 1.93 dBm (1.56 mW) Bluetooth EDR (2Mbps) : 2.75 dBm (1.88 mW) Bluetooth EDR (3Mbps) : 2.99 dBm (1.99 mW)
Antenna Type	PIFA Antenna with gain -2.42 dBi
HW Version	P3.3
SW Version	V1.300
Type of Modulation	Bluetooth (1Mbps) : GFSK Bluetooth EDR (2Mbps) : π /4-DQPSK Bluetooth EDR (3Mbps) : 8-DPSK
EUT Stage	Identical Prototype

Remark:

1. For other wireless features of this EUT, test report will be issued separately.
2. This test report recorded only product characteristics and test results of Digital Spread Spectrum (DSS).

List of Accessory:

Specification of Accessory		
AC Adapter	Brand Name	MOTOROLA
	Model Name	FMP5334A--(US plug) FMP5342A--(EU plug)
	Power Rating	I/P:100-240Vac, 50-60Hz, 0.15A; O/P: 5Vdc, 550mA
	DC Power Cord Type	1.8 meter non-shielded cable without ferrite core
Battery	Brand Name	MOTOROLA
	Model Name	OM6C
	Power Rating	3.7Vdc, 1230mAh, 4.55Wh
	Type	Li-ion
Earphone	Brand Name	Full-Sound
	Model Name	TDM-600-002
	Signal Line Type	1.7 meter non-shielded cable without ferrite core
USB Cable	Brand Name	Hon Hai
	Model Name	CUNC004B-T19-EF
	Signal Line Type	0.95 meter shielded cable without ferrite core
LCD Panel	Brand Name	WINTEK
	Model Name	WD-F3248Y-6FLW
Camera	Brand Name	Foxconn
	Model Name	C265

Remark:

1. The above EUT's information was declared by manufacturer. Please refer to the specifications or user's manual for more detailed description.
2. For accessories equipped with this EUT, please refer to the appendix of the external photo.

1.4 Testing Site

Test Site	SPORTON INTERNATIONAL INC.	
Test Site Location	No. 52, Hwa Ya 1 st Rd., Hwa Ya Technology Park, Kwei-Shan Hsiang, Tao Yuan Hsien, Taiwan, R.O.C. TEL: +886-3-3273456 / FAX: +886-3-3284978	
Test Site No.	Sporton Site No.	FCC/IC Registration No.
	03CH06-HY	TW1022/4086B-1

1.5 Applied Standards

According to the specifications of the manufacturer, the EUT must comply with the requirements of the following standards:

- FCC Part 15 Subpart C §15.247
- FCC Public Notice DA 00-705
- ANSI C63.4-2003
- IC RSS-210 Issue 7

Remark:

1. All test items were verified and recorded according to the standards and without any deviation during the test.
2. This EUT has also been tested and complied with the requirements of FCC Part 15, Subpart B (DoC), recorded in a separate test report.

1.6 Ancillary Equipment List

Item	Equipment	Trade Name	Model Name	FCC ID	Data Cable	Power Cord
1.	Bluetooth Base Station	R&S	CBT32	N/A	N/A	Unshielded, 1.8 m

2 Test Configuration of Equipment Under Test

2.1 RF Output Power

Preliminary tests were performed in different data rate and recorded the RF output power in the following table:

Channel	Frequency	Bluetooth RF Output Power		
		Data Rate / Modulation		
		GFSK	π /4-DQPSK	8-DPSK
		1Mbps	2Mbps	3Mbps
Ch00	2402MHz	1.93 dBm	2.75 dBm	2.99 dBm
Ch39	2441MHz	1.81 dBm	2.58 dBm	2.93 dBm
Ch78	2480MHz	1.64 dBm	2.37 dBm	2.73 dBm

Remark:

1. The data rate was set in 3Mbps for all the test items due to the highest RF output power.
2. The EUT is programmed to transmit signals continuously for all testing.

2.2 Test Mode

The EUT has been associated with peripherals pursuant to ANSI C63.4-2003 and configuration operated in a manner tended to maximize its emission characteristics in a typical application. Frequency range investigated: radiation (9 kHz to the 10th harmonic of the highest fundamental frequency or to 40 GHz, whichever is lower).

Pre-scanned tests were conducted to determine the final configuration from all possible combinations.

The following tables are showing the test modes as the worst cases and recorded in this report.

Test Cases			
Test Item	Data Rate / Modulation		
	Bluetooth 1Mbps GFSK	Bluetooth EDR 2Mbps π/4-DQPSK	Bluetooth EDR 3Mbps 8-DPSK
Conducted TCs	Mode 1: CH00_2402 MHz Mode 2: CH39_2441 MHz Mode 3: CH78_2480 MHz	Mode 4: CH00_2402 MHz Mode 5: CH39_2441 MHz Mode 6: CH78_2480 MHz	Mode 7: CH00_2402 MHz Mode 8: CH39_2441 MHz Mode 9: CH78_2480 MHz
Radiated TCs	N/A	N/A	Mode 1: CH00_2402 MHz Mode 2: CH39_2441 MHz Mode 3: CH78_2480 MHz
AC Conducted Emission	Mode 1 :GSM850 Idle + WLAN Link + Bluetooth Link + GPS Rx + Earphone + Adapter		
Remark: For radiated TCs, the data rate was set in 3Mbps due to the highest RF output power; only the data of these modes was reported.			

2.3 Connection Diagram of Test System

<Conduction Mode>

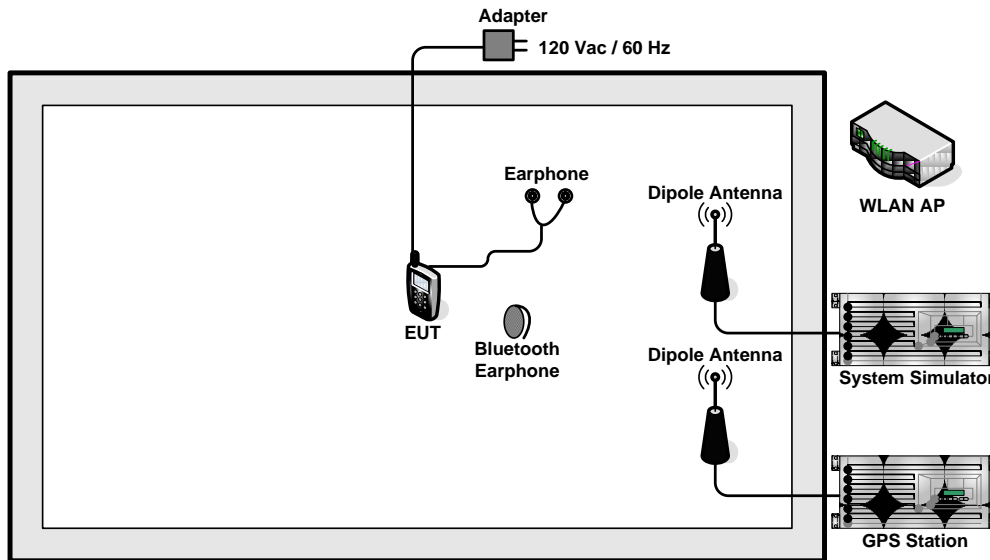

<Bluetooth Tx Mode>

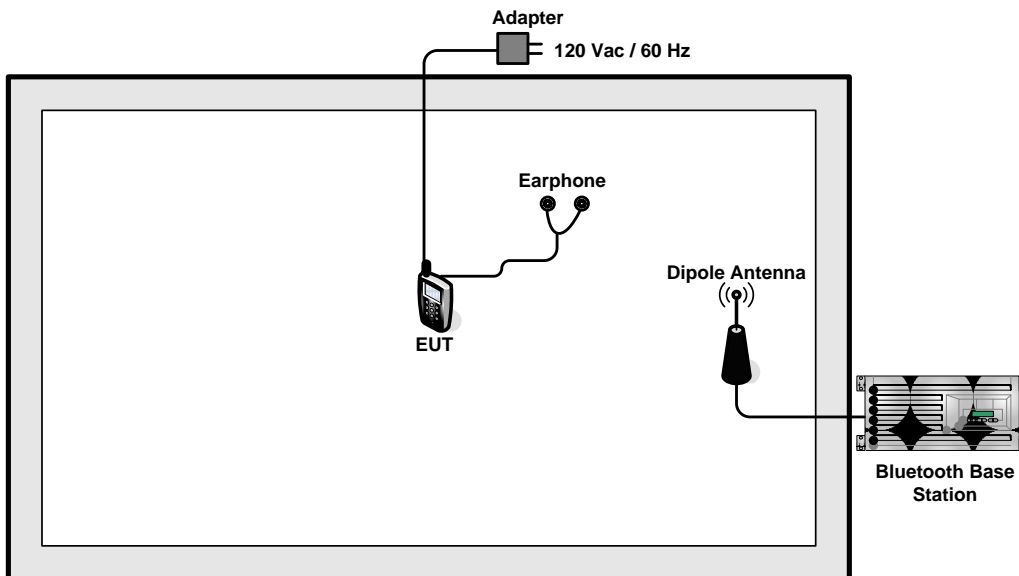

2.4 RF Utility

For Bluetooth function, the RF utility, "Bluetooth test" was installed in EUT which was programmed in order to make the EUT into the engineering modes to contact with BT base station for transmitting and receiving signals continuously.

3 Test Result

3.1 Number of Channel Measurement

3.1.1 Limits of Number of Hopping Frequency

Frequency hopping systems in the 2400-2483.5 MHz band shall use at least 15 channels.

3.1.2 Measuring Instruments

See list of measuring instruments of this test report.

3.1.3 Test Procedure

1. The testing follows FCC Public Notice DA 00-705 Measurement Guidelines.
2. The RF output of EUT was connected to the spectrum analyzer by a low loss cable.
3. The modulation types of EUT are irrelevant to number of hopping channels deviation.
4. The EUT must have its hopping function enabled. Use the following spectrum analyzer settings:
Span = the frequency band of operation; $RBW \geq 1\%$ of the span; $VBW \geq RBW$; Sweep = auto;
Detector function = peak; Trace = max hold.
5. The number of hopping frequency used is defined as the device has the numbers of total channel.

3.1.4 Test Setup

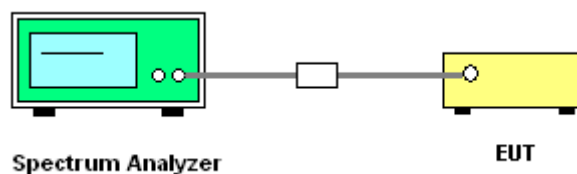

3.1.5 Test Result of Number of Hopping Frequency

Test Mode :	Mode 7~9	Temperature :	24~26°C
Test Engineer :	Andy Yeh	Relative Humidity :	46~49%
Number of Hopping Channels (Channel)		Limits (Channel)	
79		> 15	
		Pass/Fail	
		Pass	

Number of Hopping Channel Plot on Channel 00 - 78

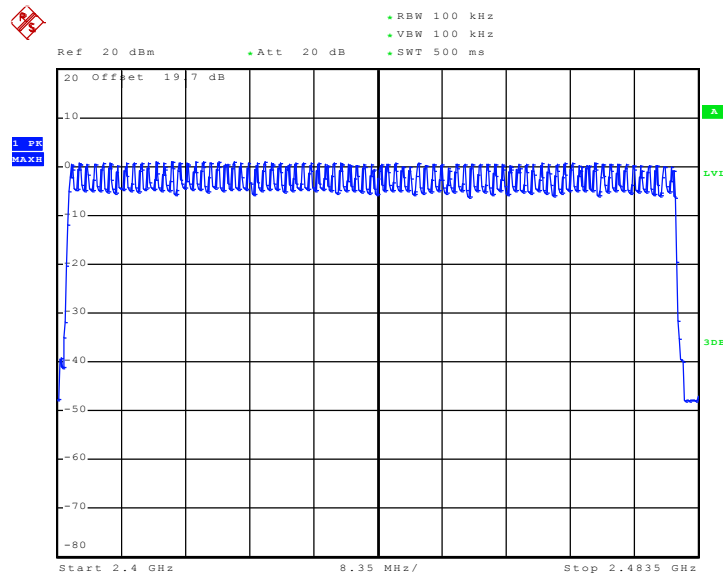

Date: 22.MAY.2010 05:38:33

3.2 20dB Bandwidth Measurement

3.2.1 Limit of 20dB Bandwidth

N/A

3.2.2 Measuring Instruments

See list of measuring instruments of this test report.

3.2.3 Test Procedures

1. The testing follows FCC Public Notice DA 00-705 Measurement Guidelines.
2. The RF output of EUT was connected to the spectrum analyzer by a low loss cable.
3. The EUT should be transmitting at its maximum data rate as the worst cases.
4. Use the following spectrum analyzer settings:
Span = approximately 2 to 3 times the 20 dB bandwidth, centered on a hopping channel;
RBW \geq 1% of the 20 dB bandwidth; VBW \geq RBW; Sweep = auto; Detector function = peak;
Trace = max hold.
5. The marker-delta reading at this point is the 20 dB bandwidth of the emission.

3.2.4 Test Setup

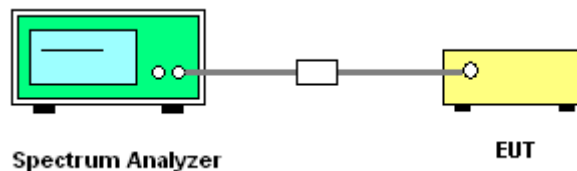



3.2.5 Test Result of 20dB Bandwidth

Test Mode :	Mode 1, 2, 3	Temperature :	24~26°C
Test Engineer :	Andy Yeh	Relative Humidity :	46~49%

Channel	Frequency (MHz)	20dB Bandwidth (MHz)
00	2402	0.789
39	2441	0.786
78	2480	0.780

20 dB Bandwidth Plot on Channel 00

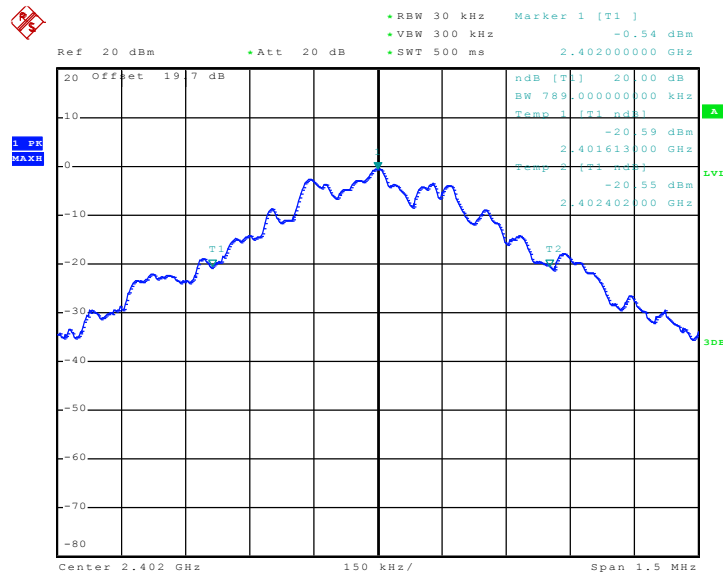

Date: 22.MAY.2010 04:24:51



20 dB Bandwidth Plot on Channel 39

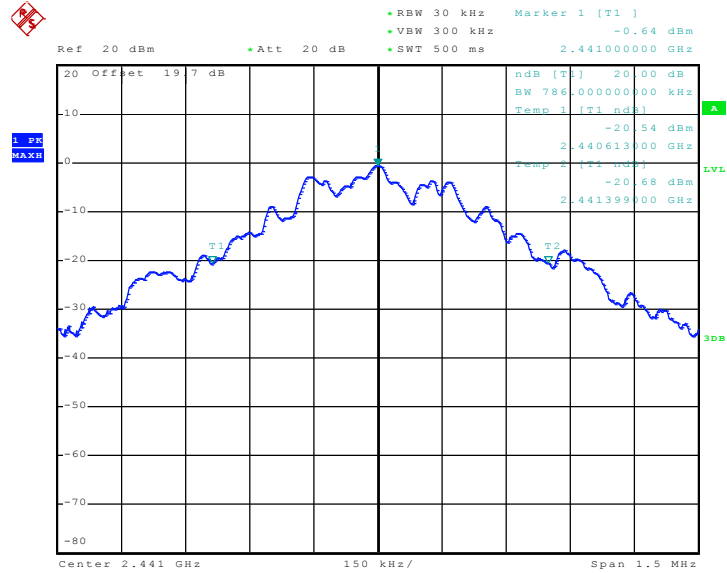

Date: 22.MAY.2010 04:25:15

20 dB Bandwidth Plot on Channel 78

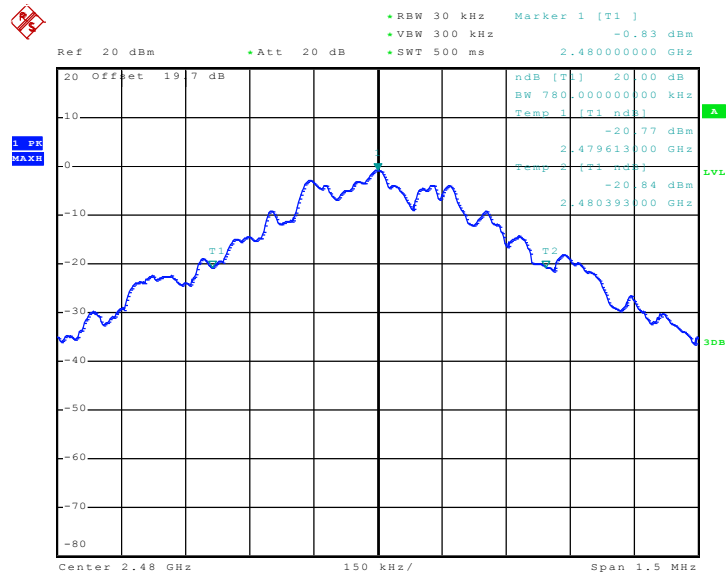

Date: 22.MAY.2010 04:25:42



Test Mode :	Mode 4, 5, 6	Temperature :	24~26°C
Test Engineer :	Andy Yeh	Relative Humidity :	46~49%

Channel	Frequency (MHz)	20dB Bandwidth (MHz)
00	2402	1.212
39	2441	1.212
78	2480	1.212

20 dB Bandwidth Plot on Channel 00

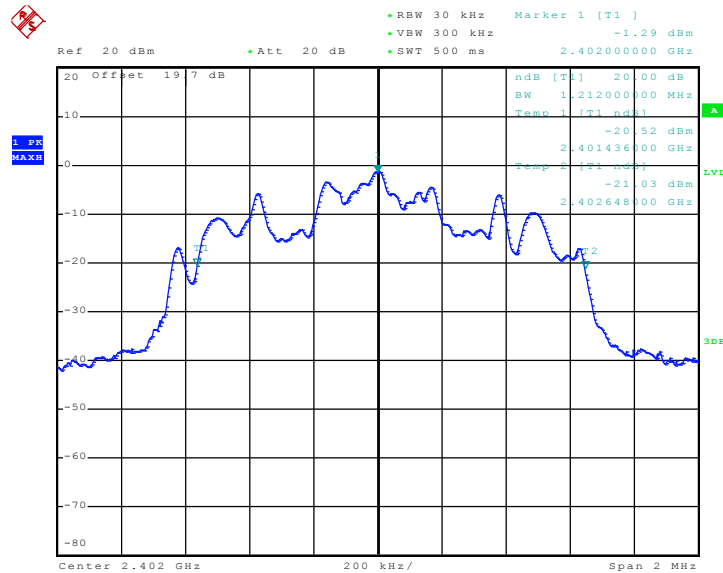

Date: 22.MAY.2010 04:28:03



20 dB Bandwidth Plot on Channel 39

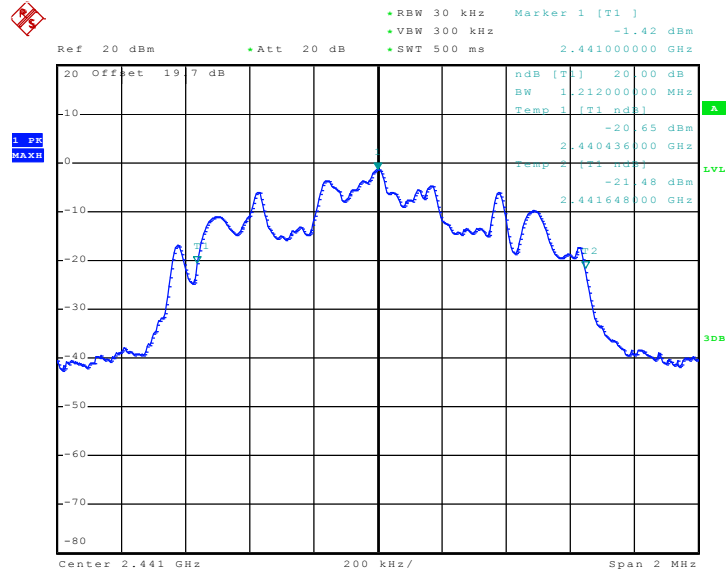

Date: 22.MAY.2010 04:28:30

20 dB Bandwidth Plot on Channel 78

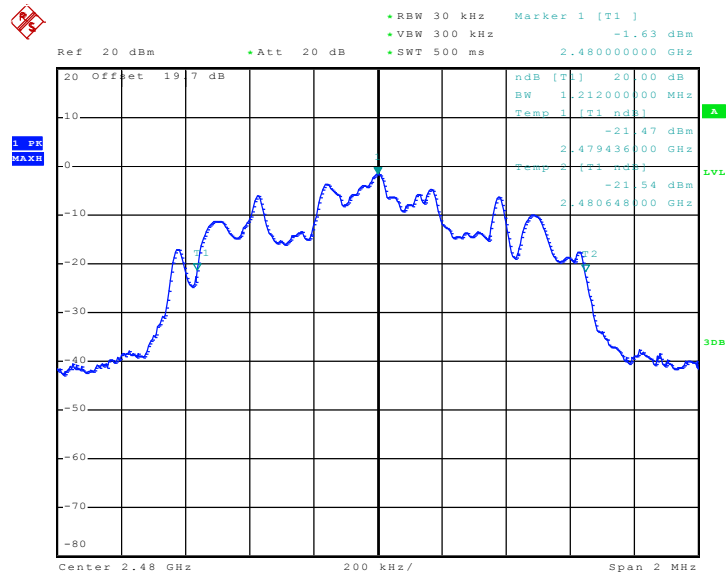

Date: 22.MAY.2010 04:29:02



Test Mode :	Mode 7, 8, 9	Temperature :	24~26°C
Test Engineer :	Andy Yeh	Relative Humidity :	46~49%

Channel	Frequency (MHz)	20dB Bandwidth (MHz)
00	2402	1.172
39	2441	1.168
78	2480	1.168

20 dB Bandwidth Plot on Channel 00

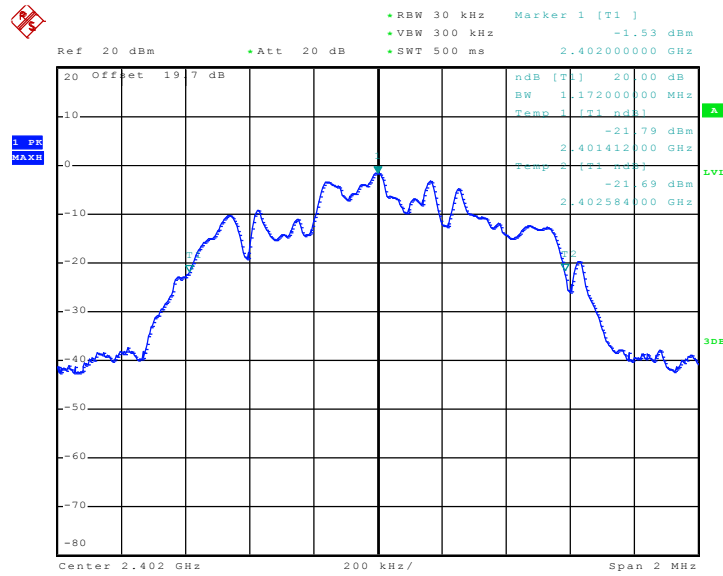

Date: 22.MAY.2010 04:29:40



20 dB Bandwidth Plot on Channel 39

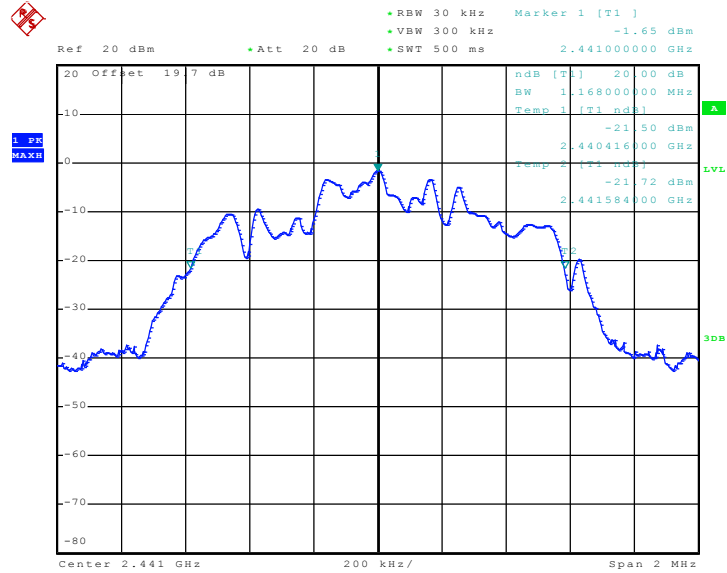

Date: 22.MAY.2010 04:30:05

20 dB Bandwidth Plot on Channel 78

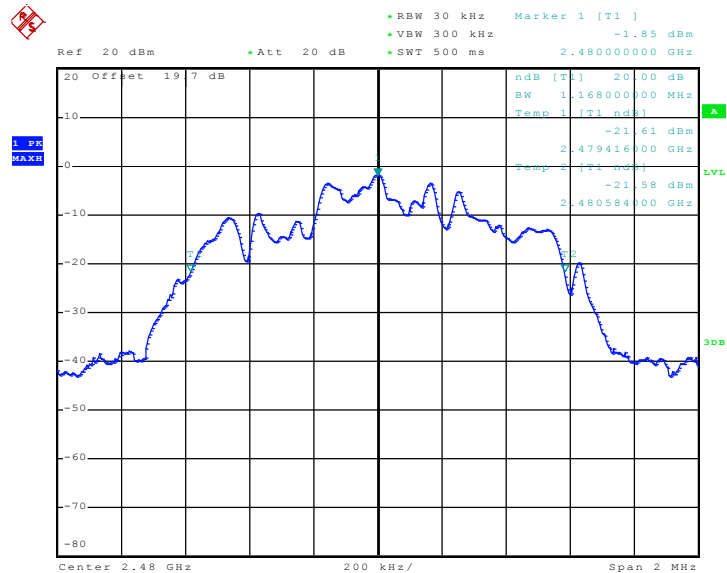

Date: 22.MAY.2010 04:30:31

3.3 Hopping Channel Separation Measurement

3.3.1 Limit of Hopping Channel Separation

Frequency hopping systems operating in the 2400-2483.5 MHz band may have hopping channel carrier frequencies that are separated by 25 kHz or two-thirds of the 20 dB bandwidth of the hopping channel, whichever is greater.

3.3.2 Measuring Instruments

See list of measuring instruments of this test report.

3.3.3 Test Procedures

1. Please refer FCC Public Notice DA 00-705 Measurement Guidelines.
2. The RF output of EUT was connected to the spectrum analyzer by a low loss cable.
3. The EUT should be transmitting at its maximum data rate as the worst cases.
4. Use the following spectrum analyzer settings:
Span = wide enough to capture the peaks of two adjacent channels; $RBW \geq 1\%$ of the span;
VBW \geq RBW; Sweep = auto; Detector function = peak; Trace = max hold.
5. Use the marker-delta function to determine the separation between the peaks of the adjacent channels.

3.3.4 Test Setup

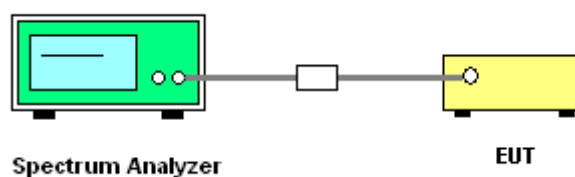



3.3.5 Test Result of Hopping Channel Separation

Test Mode :	Mode 7, 8, 9	Temperature :	24~26°C
Test Engineer :	Andy Yeh	Relative Humidity :	46~49%

Channel	Frequency (MHz)	Frequency Separation (MHz)	(2/3 of 20dB BW) Limits (MHz)	Pass/Fail
00	2402	1.008	0.781	Pass
39	2441	1.008	0.779	Pass
78	2480	1.008	0.779	Pass

Channel Separation Plot on Channel 00 - 01

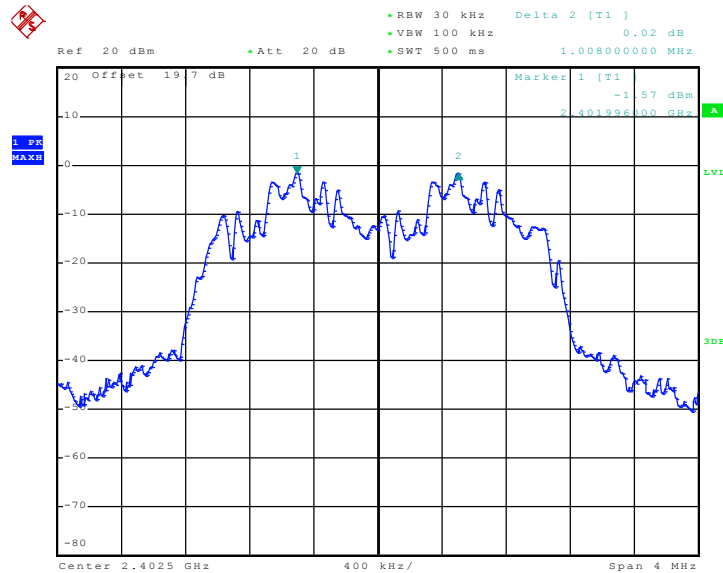

Date: 22.MAY.2010 04:36:34



Channel Separation Plot on Channel 39 - 40

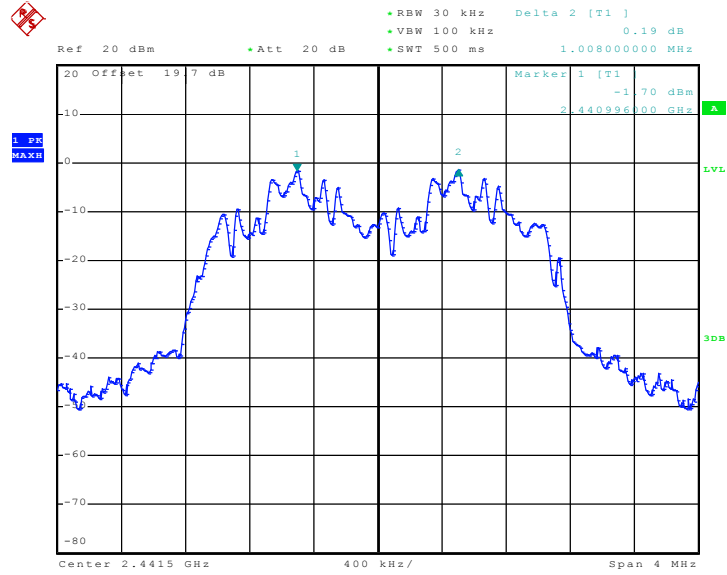

Date: 22.MAY.2010 04:37:05

Channel Separation Plot on Channel 77 - 78

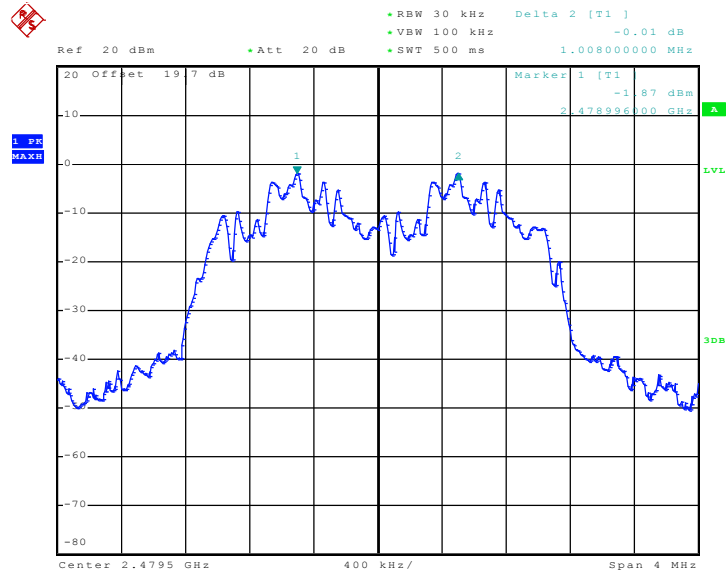

Date: 22.MAY.2010 04:37:38

3.4 Dwell Time Measurement

3.4.1 Limit of Dwell Time

The average time of occupancy on any channel shall not be greater than 0.4 seconds within a period of 0.4 seconds multiplied by the number of hopping channels employed.

3.4.2 Measuring Instruments

See list of measuring instruments of this test report.

3.4.3 Test Procedures

1. The testing follows FCC Public Notice DA 00-705 Measurement Guidelines.
2. The RF output of EUT was connected to the spectrum analyzer by a low loss cable.
3. The EUT should be transmitting at its maximum data rate as the worst cases.
4. The EUT must have its hopping function enabled. Use the following spectrum analyzer settings:
Span = zero span, centered on a hopping channel; RBW = 1 MHz; VBW ≥ RBW; Sweep = as necessary to capture the entire dwell time per hopping channel; Detector function = peak; Trace = max hold.
5. Use the marker-delta function to calculate the dwell time.

3.4.4 Test Setup

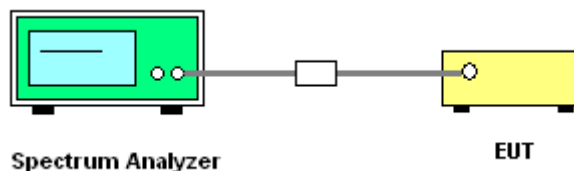

3.4.5 Test Result of Dwell Time

Test Mode :	Mode 8	Temperature :	24~26°C		
Test Engineer :	Andy Yeh	Relative Humidity :	46~49%		
Package Mode	Average Hopping Channel	Package Transfer Time (usec)	Dwell Time (sec)	Limits (sec)	Pass/Fail
DH5	2.60	2940.00	0.24	0.4	Pass

Remark:

1. Dwell Time=79(channels) x 0.4(s) x average hopping channel x package transfer time
2. 79 channels come from the Hopping Channel number.
3. Average Hopping Channel = hops/sweep time
4. t: Package Transfer Time(us)



DH5 Dwell Time (One Pulse) Plot on Channel 39

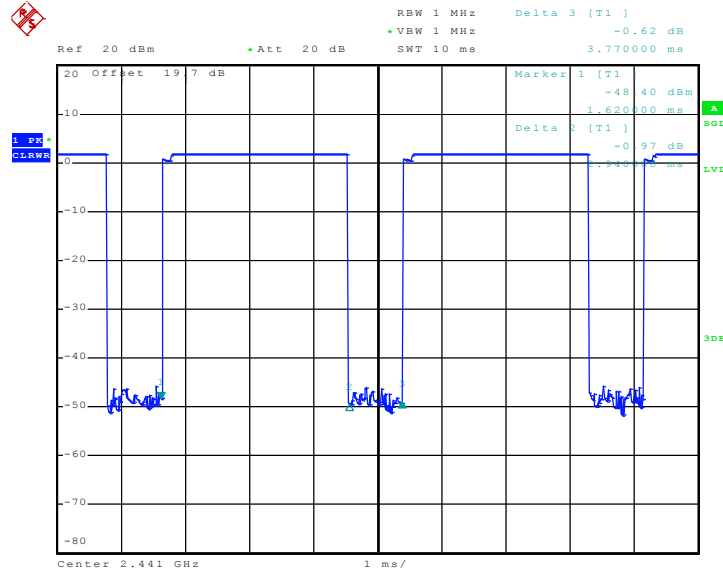

Date: 22.MAY.2010 05:05:14

DH5 Dwell Time (Count Pulses) Plot on Channel 39

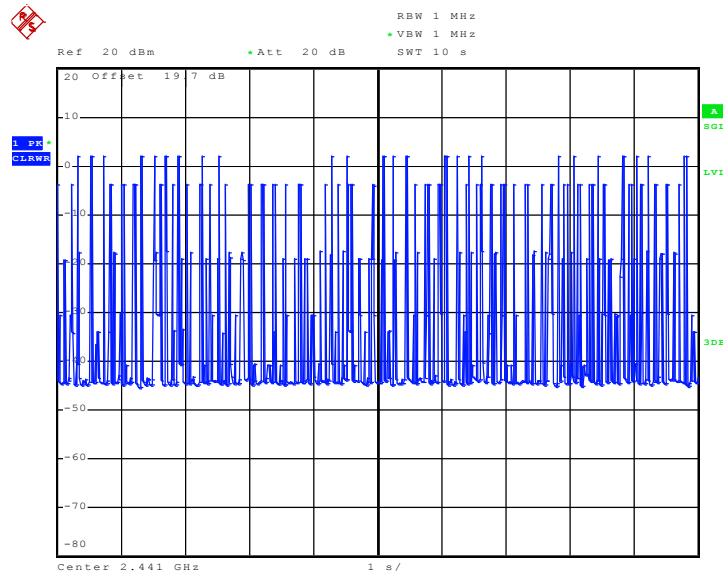

Date: 22.MAY.2010 05:10:03

3.5 Peak Output Power Measurement

3.5.1 Limit of Peak Output Power

Frequency hopping systems operating in the 2400-2483.5 MHz band employing at least 75 non-overlapping hopping channels: 1W (30 dBm).

3.5.2 Measuring Instruments

See list of measuring instruments of this test report.

3.5.3 Test Procedures

1. The testing follows FCC Public Notice DA 00-705 Measurement Guidelines.
2. The RF output of EUT was connected to the spectrum analyzer by a low loss cable.

3.5.4 Test Setup

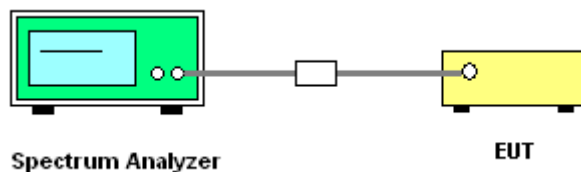

3.5.5 Test Result of Peak Output Power

Test Mode :	Mode 7, 8, 9	Temperature :	24~26°C
Test Engineer :	Andy Yeh	Relative Humidity :	46~49%

Channel	Frequency (MHz)	RF Power (dBm)		
		π /4-DQPSK	Max. Limits (dBm)	Pass/Fail
		3 Mbps		
00	2402	2.99	30	Pass
39	2441	2.93	30	Pass
78	2480	2.73	30	Pass



Peak Output Power Plot on Channel 00

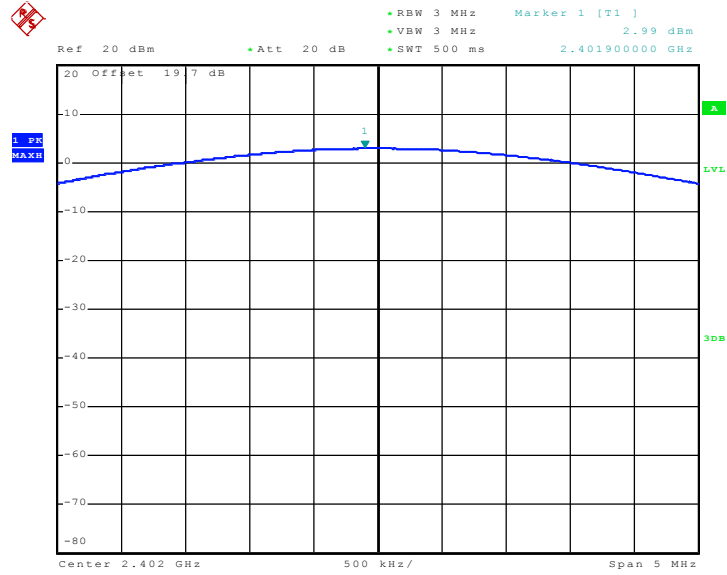

Date: 22.MAY.2010 04:21:31

Peak Output Power Plot on Channel 39

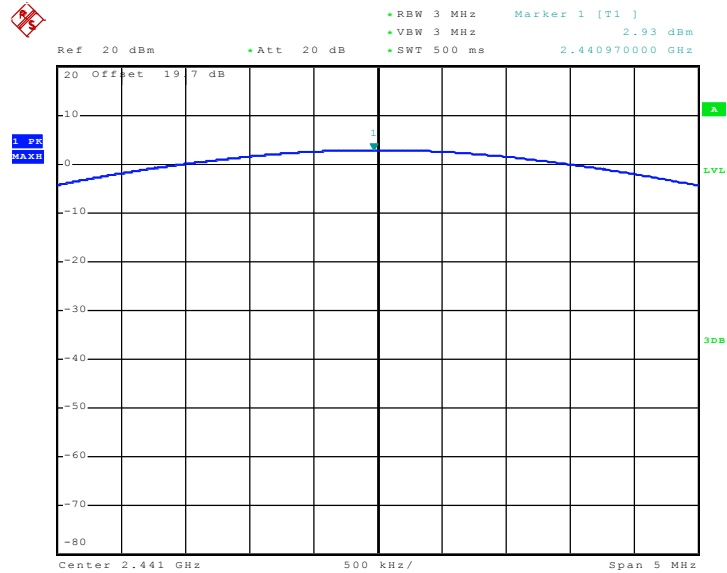

Date: 22.MAY.2010 04:21:11



Peak Output Power Plot on Channel 78

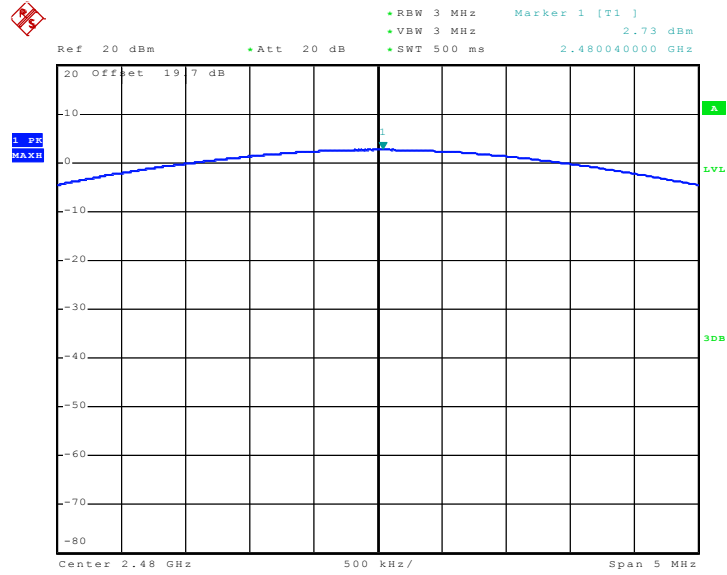

Date: 22.MAY.2010 04:20:23

3.6 Band Edges Measurement

3.6.1 Limit of Band Edges

In any 100 kHz bandwidth outside the intentional radiation frequency band, the radio frequency power shall be at least 20 dB below the highest level of the radiated power. In addition, radiated emissions which fall in the restricted bands must also comply with the radiated emission limits.

3.6.2 Measuring Instruments

See list of measuring instruments of this test report.

3.6.3 Test Procedures

1. The testing follows the guidelines in ANSI C63.4-2003 and FCC Public Notice DA 00-705 Measurement Guidelines.
2. RF antenna conducted test: Set RBW = 1MHz, Video bandwidth (VBW) \geq RBW. Band edge emissions must be at least 20 dB down from the highest emission level within the authorized band as measured with a 1MHz RBW. Note: If the device complies with the use of power option 2 the attenuation under this paragraph shall be 30 dB instead of 20 dB.
3. Radiated emission test: Applies to band edge emissions that fall in the restricted bands listed in FCC Section 15.205. The maximum permitted average field strength is listed in FCC Section 15.209. A pre-amp is necessary for this measurement. For measurements above 1 GHz, set RBW = 1MHz, VBW = 1MHz, Sweep: Auto for Peak; set RBW = 1MHz, VBW = 10 Hz, Sweep: Auto for Average. If the emission is pulsed, modify the unit for continuous operation; use the settings shown above, then correct the reading by subtracting the peak-average correction factor, derived from the appropriate duty cycle calculation. See FCC Section 15.35(b) and (c).
4. In case the emission is fail due to the used RBW / VBW is too wide, marker-delta method of FCC Public Notice DA 00-705 will be followed.

3.6.4 Test Setup

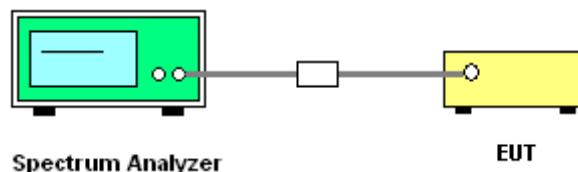



3.6.5 Test Result of Radiated Band Edges

Test Mode :	Mode 1	Temperature :	21~23°C
Test Channel :	00	Relative Humidity :	44~46%
		Test Engineer :	Elvis Chen

ANTENNA POLARITY : HORIZONTAL										
Frequency (MHz)	Level (dBuV/m)	Over Limit (dB)	Limit Line (dBuV/m)	Read Level (dBuV)	Antenna Factor (dB)	Cable Loss (dB)	Preamp Factor (dB)	Ant Pos (cm)	Table Pos (deg)	Remark
2369.09	46.2	-27.8	74	44.88	31.83	3.89	34.4	104	356	Peak
2369.09	35.67	-18.33	54	34.35	31.83	3.89	34.4	104	356	Average

ANTENNA POLARITY : VERTICAL										
Frequency (MHz)	Level (dBuV/m)	Over Limit (dB)	Limit Line (dBuV/m)	Read Level (dBuV)	Antenna Factor (dB)	Cable Loss (dB)	Preamp Factor (dB)	Ant Pos (cm)	Table Pos (deg)	Remark
2337.17	46.04	-27.96	74	44.81	31.78	3.86	34.41	100	308	Peak
2337.17	34.75	-19.25	54	33.52	31.78	3.86	34.41	100	308	Average



Test Mode :	Mode 3	Temperature :	21~23°C
Test Channel :	78	Relative Humidity :	44~46%
		Test Engineer :	Elvis Chen

ANTENNA POLARITY : HORIZONTAL										
Frequency (MHz)	Level (dBuV/m)	Over Limit (dB)	Limit Line (dBuV/m)	Read Level (dBuV)	Antenna Factor (dB)	Cable Loss (dB)	Preamp Factor (dB)	Ant Pos (cm)	Table Pos (deg)	Remark
2483.5	65.27	-8.73	74	63.61	31.98	4.05	34.37	183	9	Peak
2483.5	25.99	-28.01	54	24.33	31.98	4.05	34.37	183	9	Average

Summary results of marker-delta method:

Test mode	Maximum field strength of the fundamental emission (dBµV/m)	Delta Result (dB)	Average Result (dBµV/m)	Average Limit (dBµV/m)	Margin (dB)	Result
Single Carrier Mode	83.66	58.77	24.89	54	-29.11	Pass
Hopping Mode	83.66	57.67	25.99	54	-28.01	Pass

Note : Average result = Maximum field strength – Delta result

ANTENNA POLARITY : VERTICAL										
Frequency (MHz)	Level (dBuV/m)	Over Limit (dB)	Limit Line (dBuV/m)	Read Level (dBuV)	Antenna Factor (dB)	Cable Loss (dB)	Preamp Factor (dB)	Ant Pos (cm)	Table Pos (deg)	Remark
2483.5	58.44	-15.56	74	56.78	31.98	4.05	34.37	100	266	Peak
2483.5	25.7	-28.3	54	24.04	31.98	4.05	34.37	100	266	Average

Summary results of marker-delta method:

Test mode	Maximum field strength of the fundamental emission (dBµV/m)	Delta Result (dB)	Average Result (dBµV/m)	Average Limit (dBµV/m)	Margin (dB)	Result
Single Carrier Mode	77.54	51.84	25.70	54	-28.30	Pass
Hopping Mode	77.54	51.92	25.62	54	-28.38	Pass

Note : Average result = Maximum field strength – Delta result



Test Mode :	Mode 3	Temperature :	21~23°C
Test Channel :	78	Relative Humidity :	44~46%
Test Engineer :	Elvis Chen	Polarization :	Horizontal

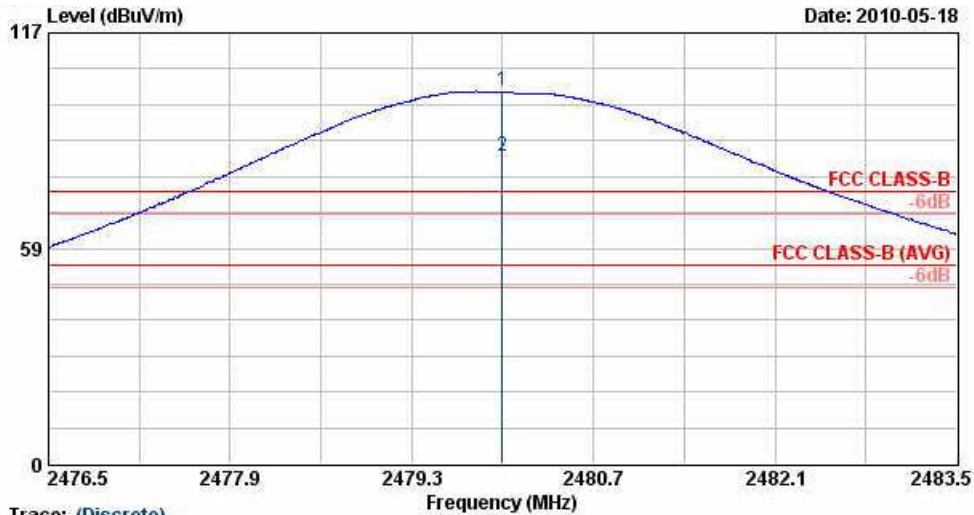

Trace: (Discrete)

Site : 03CH06-HY
 Condition : FCC CLASS-B, 3m HF-ANT_090624 HORIZONTAL
 Project : FR 981906-15
 Memo : Mode 3

	Freq	Level	Over Limit	Limit Line	Read Level	Antenna Factor	Cable Loss	Preamp Factor	Ant Pos	Table Pos	Remark
	MHz	dBuV/m	dB	dBuV/m	dBuV	dB/m	dB	dB	cm	deg	
1 @	2480.00	101.13	27.13	74.00	99.47	31.98	4.05	34.37	183	9	Peak
2 @	2480.00	83.66	29.66	54.00	82.00	31.98	4.05	34.37	183	9	Average

* Maximum field strength of the fundamental emission



Test Mode :	Mode 3	Temperature :	21~23°C
Test Channel :	78	Relative Humidity :	44~46%
Test Engineer :	Elvis Chen	Polarization :	Horizontal

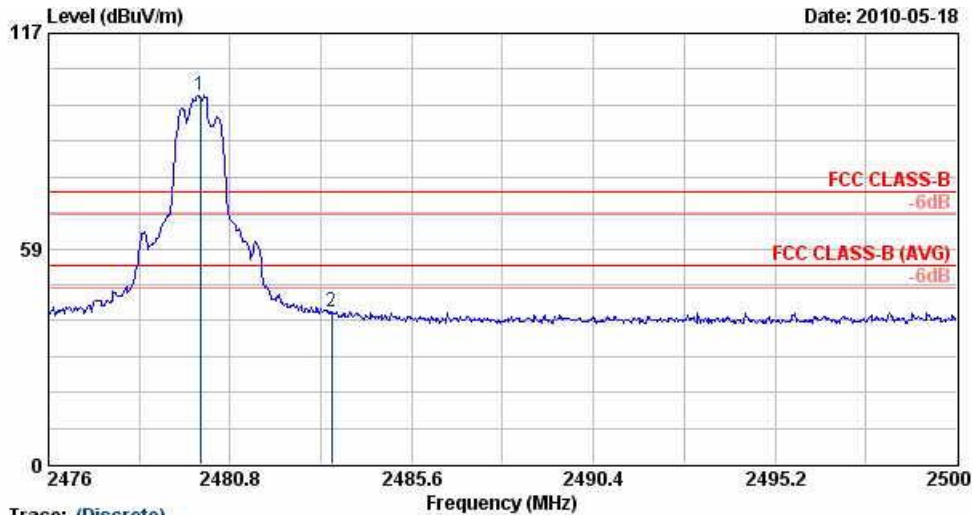

Trace: (Discrete)
 Site : 03CH06-HY
 Condition : FCC CLASS-B 3m HF-ANT_000824 HORIZONTAL
 Project : FR 981906-15
 Memo : Mode 3

	Freq	Level	Over Limit	Limit Line	Read Level	Antenna Factor	Cable Loss	Preamp Factor	Ant Pos	Table Pos	Remark
	MHz	dBuV/m	dB	dBuV/m	dBuV	dB/m	dB	dB	cm	deg	
1 @	2480.00	100.12	26.12	74.00	98.46	31.98	4.05	34.37	183	9	Peak
2	2483.49	41.35	-32.65	74.00	39.70	31.98	4.05	34.37	183	9	Peak

* Marker-Delta Method (RBW/VBW=100KHz): 58.77 dB , single carrier Mode



Test Mode :	Mode 3	Temperature :	21~23°C
Test Channel :	78	Relative Humidity :	44~46%
Test Engineer :	Elvis Chen	Polarization :	Horizontal

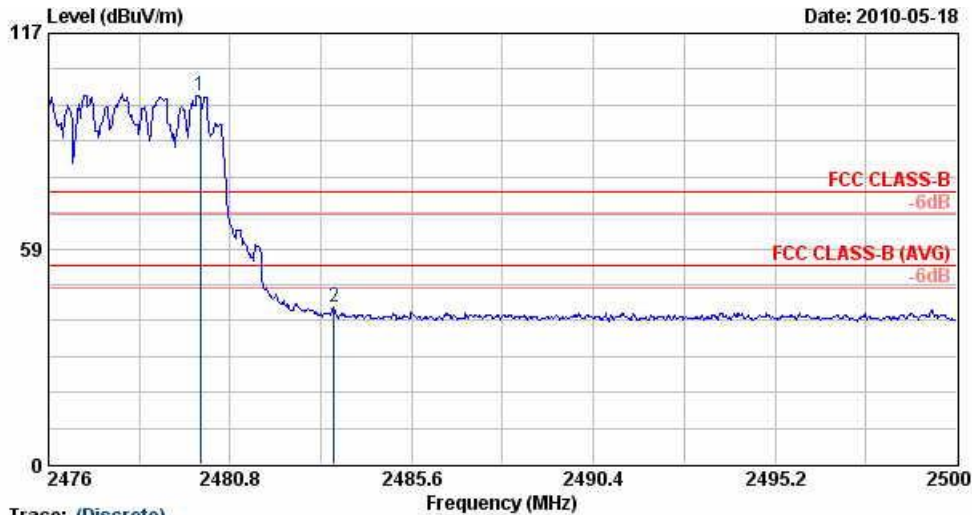

Trace: (Discrete)
 Site : 08CH06-HY
 Condition : FCC CLASS-B 3m HF-ANT_000824 HORIZONTAL
 Project : FR 981906-15
 Memo : Mode 3

	Freq	Level	Over Limit	Limit Line	ReadAntenna	Cable Preamp	Ant	Table	Remark	
	MHz	dBUV/m	dB	dBUV/m	dBUV	dB/m	dB	cm	deg	
1 @	2480.00	100.17	26.17	74.00	98.51	31.98	4.05	34.37	183	9 Peak
2	2483.54	42.50	-31.50	74.00	40.85	31.98	4.05	34.37	183	9 Peak

* Marker-Delta Method (RBW/VBW=100KHz): 57.67 dB , Hopping Mode



Test Mode :	Mode 3	Temperature :	21~23°C
Test Channel :	78	Relative Humidity :	44~46%
Test Engineer :	Elvis Chen	Polarization :	Vertical

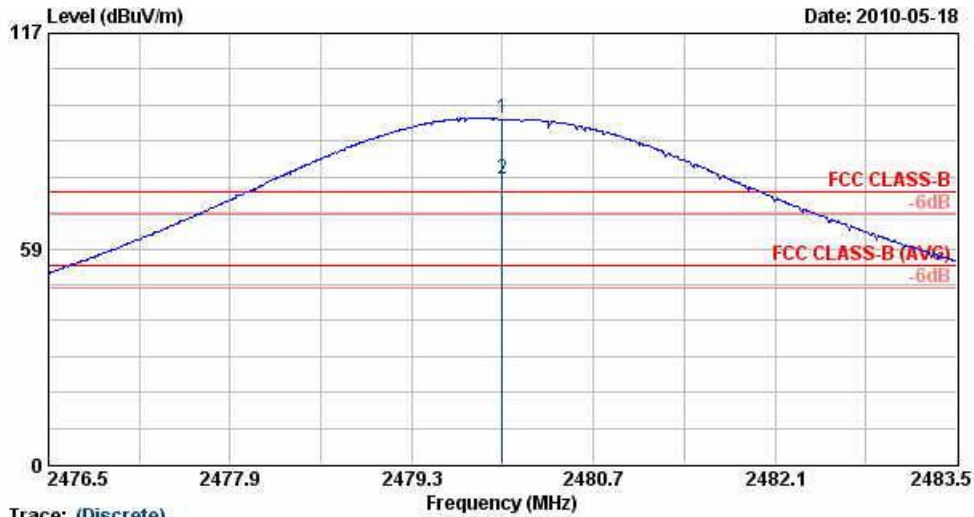

Trace: (Discrete)
 Site : 03CH06-HY
 Condition : FCC CLASS-B 3m HF-ANT_000824 VERTICAL
 Project : FR 981906-15
 Memo : Mode 3

	Freq	Level	Over Limit	Limit Line	Read Level	Antenna Factor	Cable Loss	Preamp Factor	Ant Pos	Table Pos	Remark
	MHz	dBuV/m	dB	dBuV/m	dBuV	dB/m	dB	dB	cm	deg	
1	X	2480.00	93.97	19.97	74.00	92.32	31.98	4.05	34.37	100	266 Peak
2	X	2480.00	77.54	23.54	54.00	75.88	31.98	4.05	34.37	100	266 Average

* Maximum field strength of the fundamental emission



Test Mode :	Mode 3	Temperature :	21~23°C
Test Channel :	78	Relative Humidity :	44~46%
Test Engineer :	Elvis Chen	Polarization :	Vertical

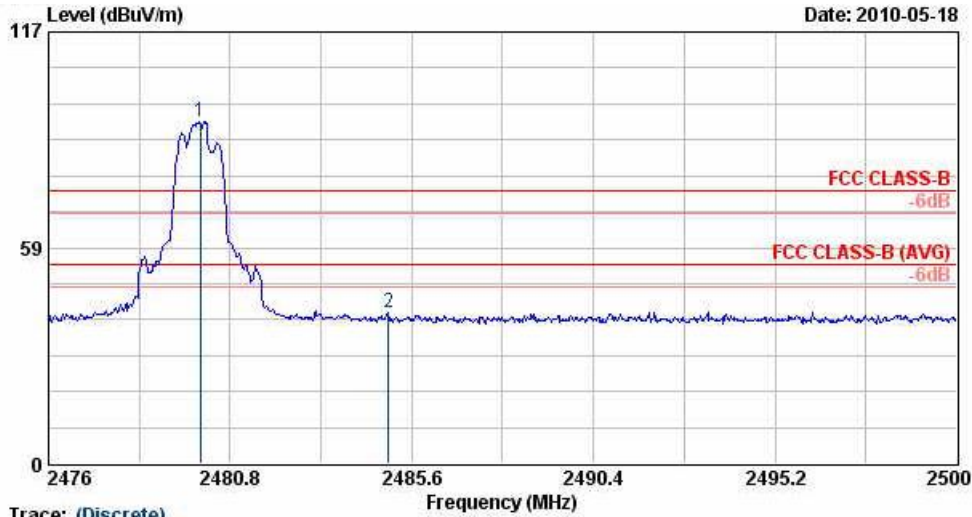

Trace: (Discrete)

Site : 03CHD6-HY
 Condition : FCC CLASS-B 3m HF-ANT_090624 VERTICAL
 Project : FR 981906-15
 Memo : Mode 3

	Freq	Level	Over Limit	Limit Line	Read Level	Antenna Factor	Cable Loss	Preamp Factor	Ant Pos	Table Pos	Remark
	MHz	dBuV/m	dB	dBuV/m	dBuV	dB/m	dB	dB	cm	deg	
1 X	2480.00	92.86	18.86	74.00	91.20	31.98	4.05	34.37	100	266	Peak
2	2484.98	41.02	-32.98	74.00	39.36	31.98	4.05	34.37	100	266	Peak

* Marker-Delta Method (RBW/VBW=100KHz): 51.84 dB , single carrier Mode



Test Mode :	Mode 3	Temperature :	21~23°C
Test Channel :	78	Relative Humidity :	44~46%
Test Engineer :	Elvis Chen	Polarization :	Vertical

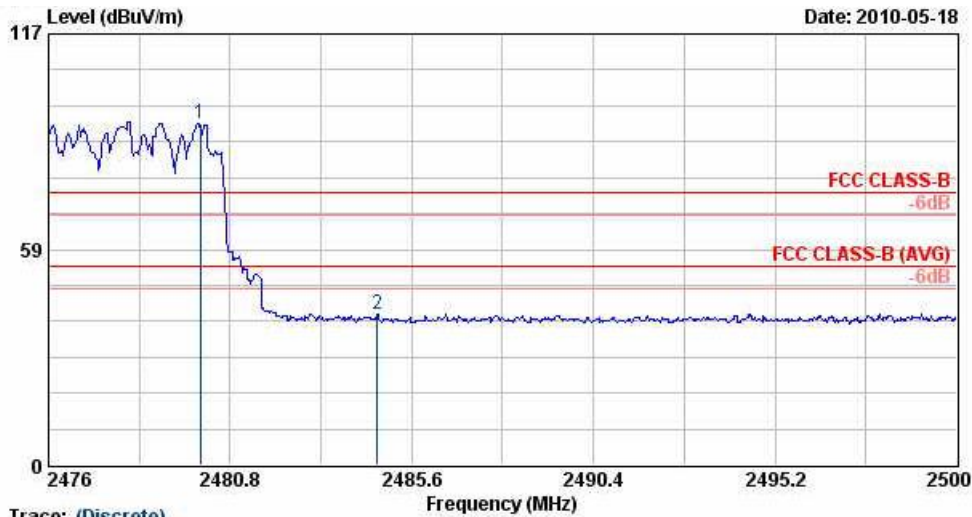

Trace: (Discrete)

Site : 03CH06-HY
 Condition : FCC CLASS-B, 3m HF-ANT_090824 VERTICAL
 Project : FR 981906-15
 Memo : Mode 3

	Freq	Level	Over Limit	Limit Line	Read Level	Antenna Factor	Cable Loss	Preamp Factor	Ant Pos	Table Pos	Remark
	MHz	dBuV/m	dB	dBuV/m	dBuV	dB/m	dB	dB	cm	deg	
1	X	2480.00	92.79	18.79	74.00	91.14	31.98	4.05	34.37	100	266 Peak
2		2484.69	40.87	-33.13	74.00	39.22	31.98	4.05	34.37	100	266 Peak

* Marker-Delta Method (RBW/VBW=100KHz): 51.92 dB , Hopping Mode

3.6.6 Test Result of Conducted Band Edges

Test Mode :	Mode 1 and 3	Temperature :	24~26°C
Test Channel :	00 and 78	Relative Humidity :	46~49%
		Test Engineer :	Andy Yeh

Low Band Edge Plot on Channel 00

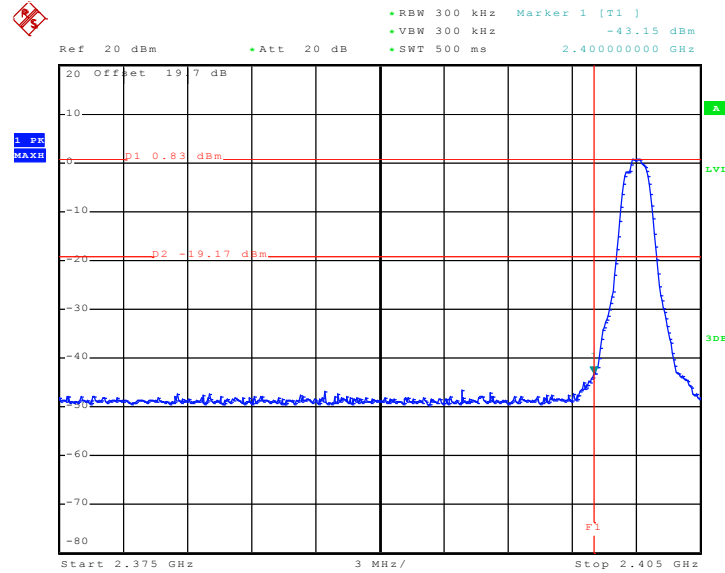

Date: 22.MAY.2010 04:47:18

High Band Edge Plot on Channel 78

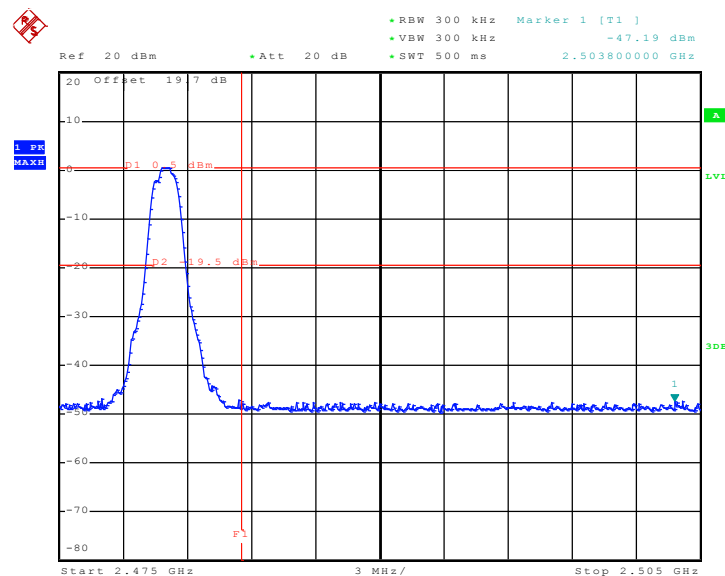

Date: 22.MAY.2010 04:50:32

3.7 Spurious Emission Measurement

3.7.1 Limit of Spurious Emission Measurement

All harmonics/spurs must be at least 20 dB down from the highest emission level within the authorized band.

3.7.2 Measuring Instruments

See list of measuring instruments of this test report.

3.7.3 Test Procedure

1. The transmitter output was connected to the spectrum analyzer via a low lose cable.
2. Set RBW = 100 kHz, Video bandwidth (VBW) \geq RBW, scan up through 10th harmonic. All harmonics / spurs must be at least 20 dB down from the highest emission level within the authorized band as measured with a 100 kHz RBW.

3.7.4 Test Setup

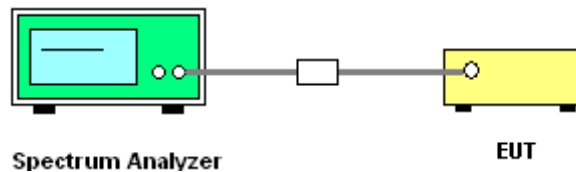

3.7.5 Test Result

Test Mode :	Mode 7	Temperature :	24~26°C
Test Channel :	00	Relative Humidity :	46~49%
		Test Engineer :	Andy Yeh

Conducted Spurious Emission Plot between 9 kHz ~ 3 GHz

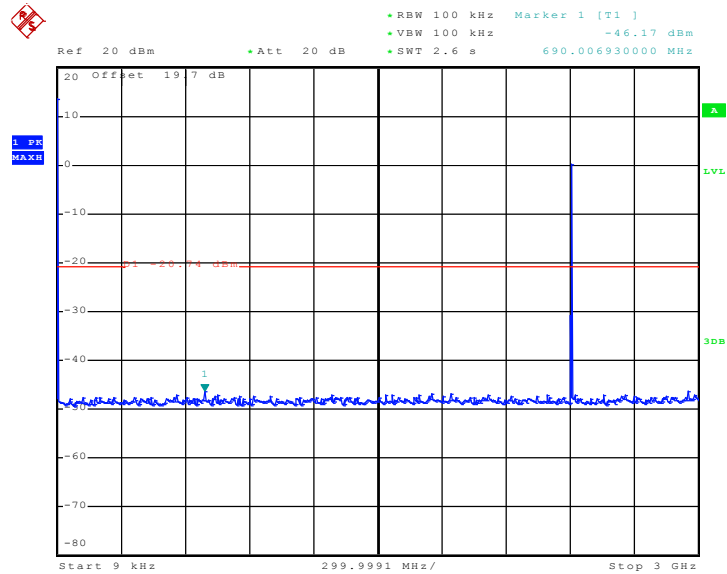

Date: 22.MAY.2010 05:56:31

Conducted Spurious Emission Plot between 1 GHz ~ 25 GHz

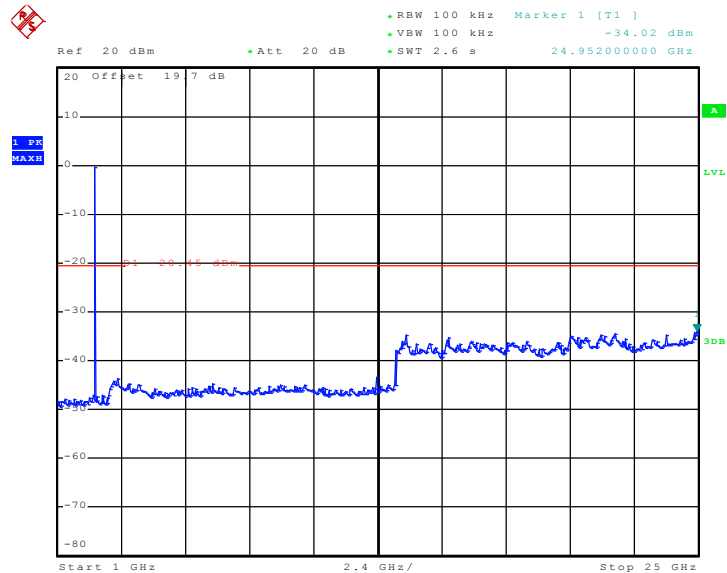

Date: 22.MAY.2010 05:55:08



Test Mode :	Mode 8	Temperature :	24~26°C
Test Channel :	39	Relative Humidity :	46~49%
		Test Engineer :	Andy Yeh

Conducted Spurious Emission Plot between 9 kHz ~ 3 GHz

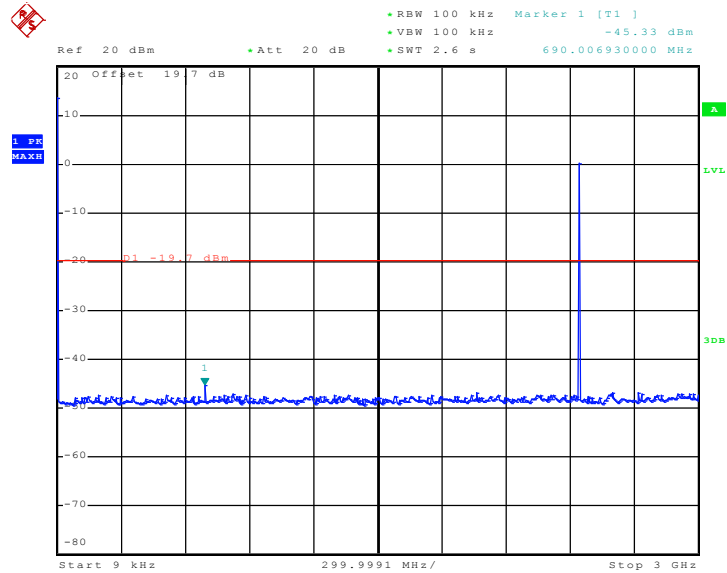

Date: 22.MAY.2010 05:57:44

Conducted Spurious Emission Plot between 1 GHz ~ 25 GHz

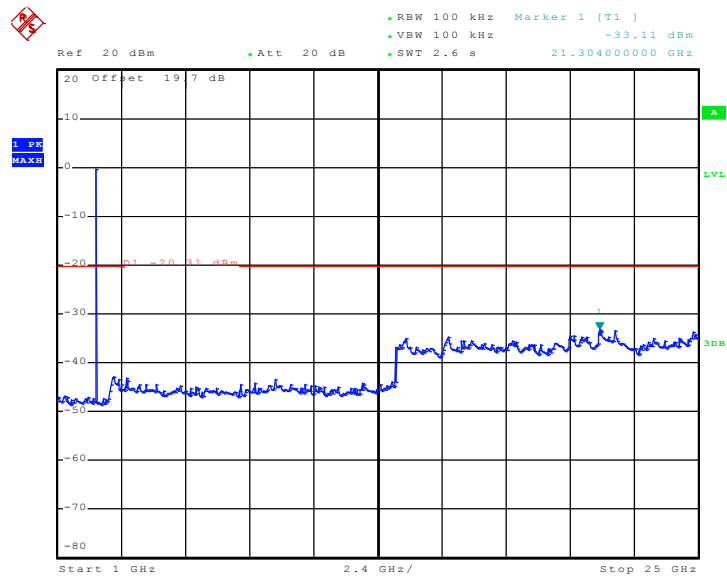

Date: 22.MAY.2010 05:54:29



Test Mode :	Mode 9	Temperature :	24~26°C
Test Channel :	78	Relative Humidity :	46~49%
		Test Engineer :	Andy Yeh

Conducted Spurious Emission Plot between 9 kHz ~ 3 GHz

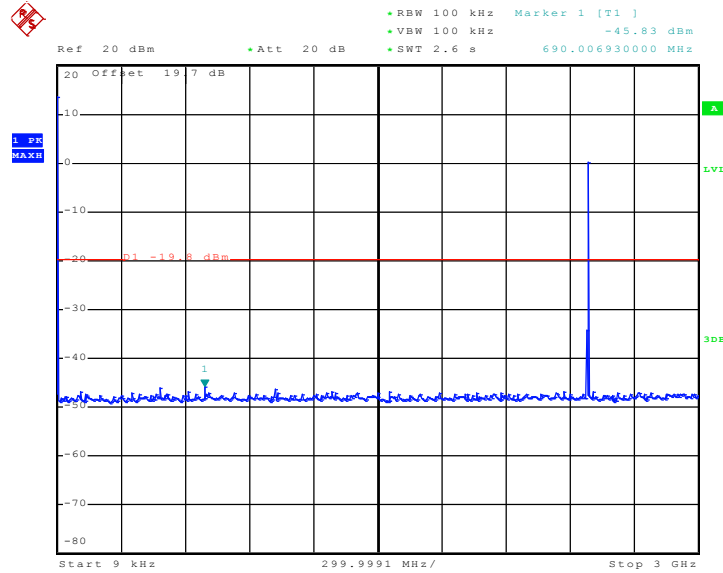

Date: 22.MAY.2010 05:59:59

Conducted Spurious Emission Plot between 1 GHz ~ 25 GHz

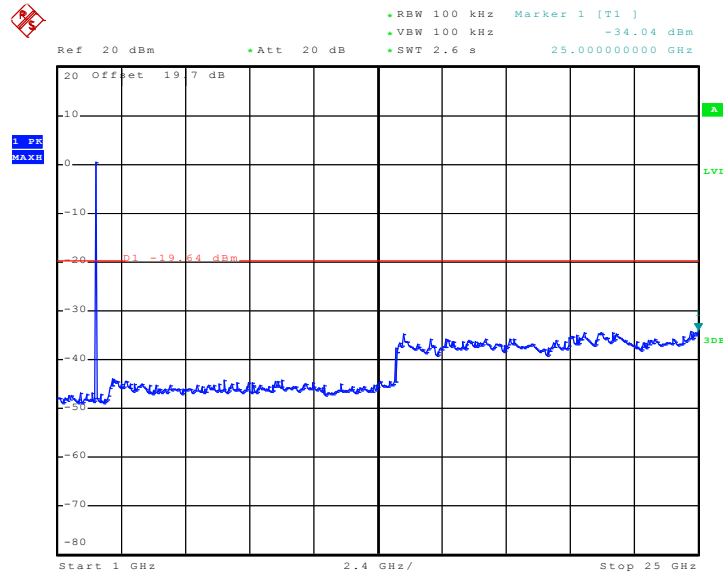

Date: 22.MAY.2010 05:52:27

3.8 AC Conducted Emission Measurement

3.8.1 Limit of AC Conducted Emission

For equipment that is designed to be connected to the public utility (AC) power line, the radio frequency voltage that is conducted back onto the AC power line on any frequency or frequencies within the band 150 kHz to 30 MHz shall not exceed the limits in the following table.

Frequency of emission (MHz)	Conducted limit (dBuV)	
	Quasi-peak	Average
0.15-0.5	66 to 56*	56 to 46*
0.5-5	56	46
5-30	60	50

*Decreases with the logarithm of the frequency.

3.8.2 Measuring Instruments

See list of measuring instruments of this test report.

3.8.3 Test Procedures

5. Please follow the guidelines in ANSI C63.4-2003.
6. The EUT was placed 0.4 meter from the conducting wall of the shielding room was kept at least 80 centimeters from any other grounded conducting surface.
7. Connect EUT to the power mains through a line impedance stabilization network (LISN).
8. All the support units are connecting to the other LISN.
9. The LISN provides 50 ohm coupling impedance for the measuring instrument.
10. The FCC states that a 50 ohm, 50 microhenry LISN should be used.
11. Both sides of AC line were checked for maximum conducted interference.
12. The frequency range from 150 kHz to 30 MHz was searched.
13. Set the test-receiver system to Peak Detect Function and specified bandwidth with Maximum Hold Mode.

3.8.4 Test Setup

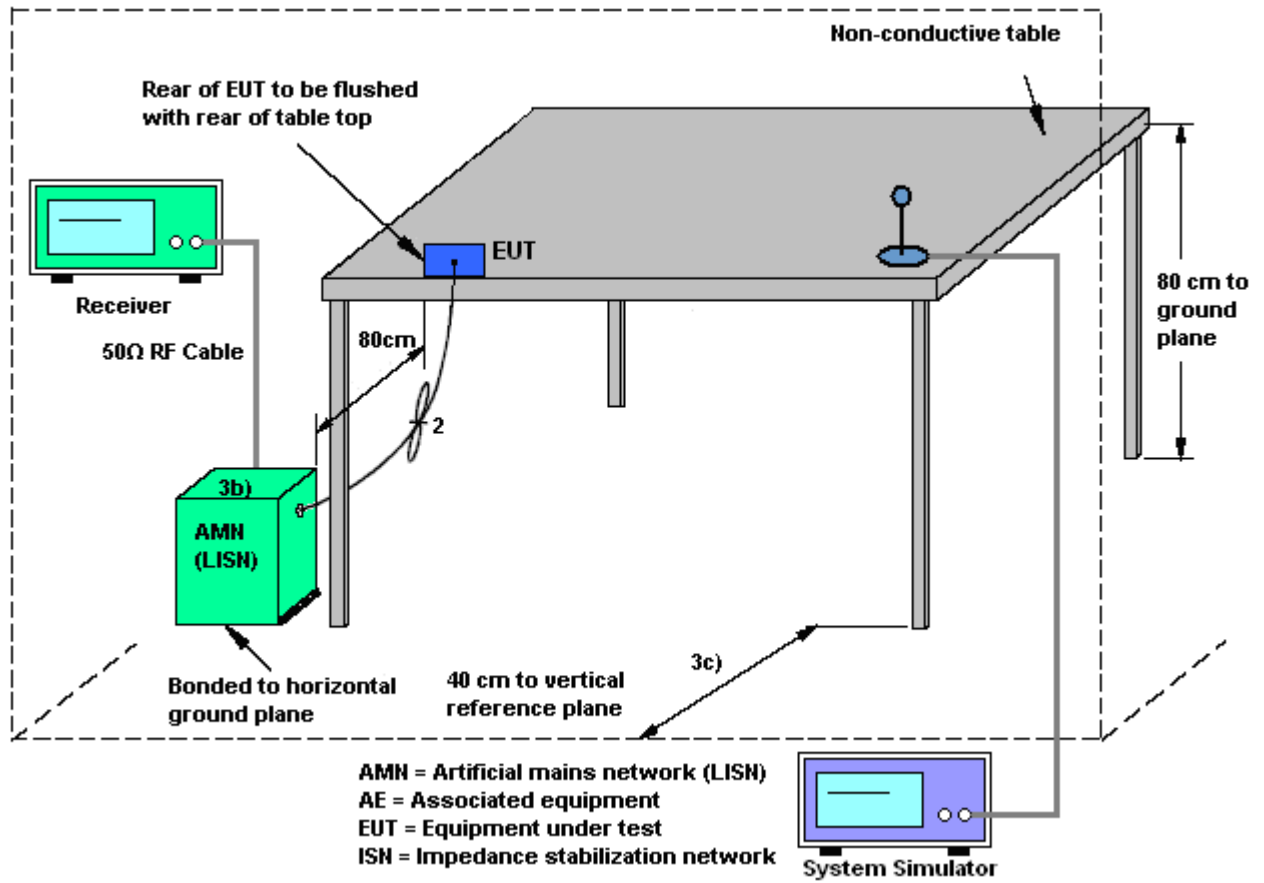

3.8.5 Test Result of AC Conducted Emission

Test Mode :	Mode 1	Temperature :	20~22°C
Test Engineer :	Novic Jiang	Relative Humidity :	40~42%
Test Voltage :	120Vac / 60Hz	Phase :	Line
Function Type :	GSM850 Idle + WLAN Link + Bluetooth Link + GPS Rx + Earphone + Adapter		
Remark :	All emissions not reported here are more than 10 dB below the prescribed limit.		

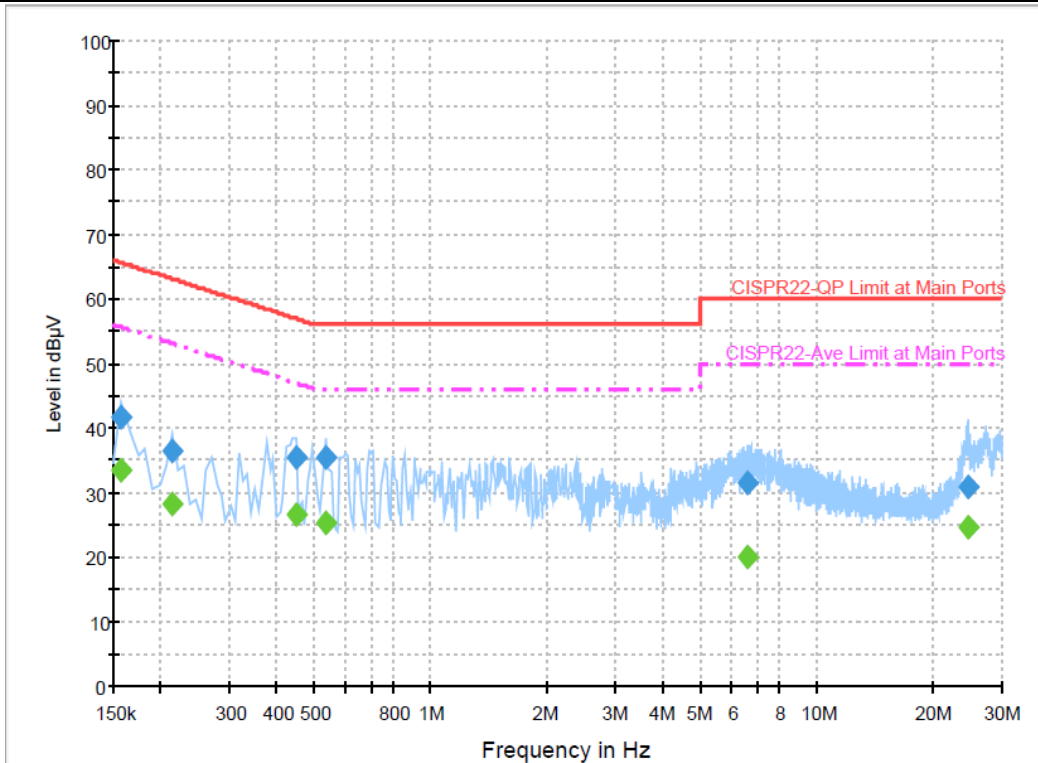

Final Result 1

Frequency (MHz)	QuasiPeak (dBµV)	Filter	Line	Corr. (dB)	Margin (dB)	Limit (dBµV)
0.158000	41.7	Off	L1	19.3	23.9	65.6
0.214000	36.3	Off	L1	19.3	26.7	63.0
0.446000	35.4	Off	L1	19.3	21.5	56.9
0.534000	35.4	Off	L1	19.3	20.6	56.0
6.566000	31.5	Off	L1	19.5	28.5	60.0
24.430000	30.8	Off	L1	19.8	29.2	60.0

Final Result 2

Frequency (MHz)	Average (dBµV)	Filter	Line	Corr. (dB)	Margin (dB)	Limit (dBµV)
0.158000	33.4	Off	L1	19.3	22.2	55.6
0.214000	28.3	Off	L1	19.3	24.7	53.0
0.446000	26.5	Off	L1	19.3	20.4	46.9
0.534000	25.1	Off	L1	19.3	20.9	46.0
6.566000	20.0	Off	L1	19.5	30.0	50.0
24.430000	24.5	Off	L1	19.8	25.5	50.0



Test Mode :	Mode 1	Temperature :	20~22°C
Test Engineer :	Novic Jiang	Relative Humidity :	40~42%
Test Voltage :	120Vac / 60Hz	Phase :	Neutral
Function Type :	GSM850 Idle + WLAN Link + Bluetooth Link + GPS Rx + Earphone + Adapter		
Remark :	All emissions not reported here are more than 10 dB below the prescribed limit.		

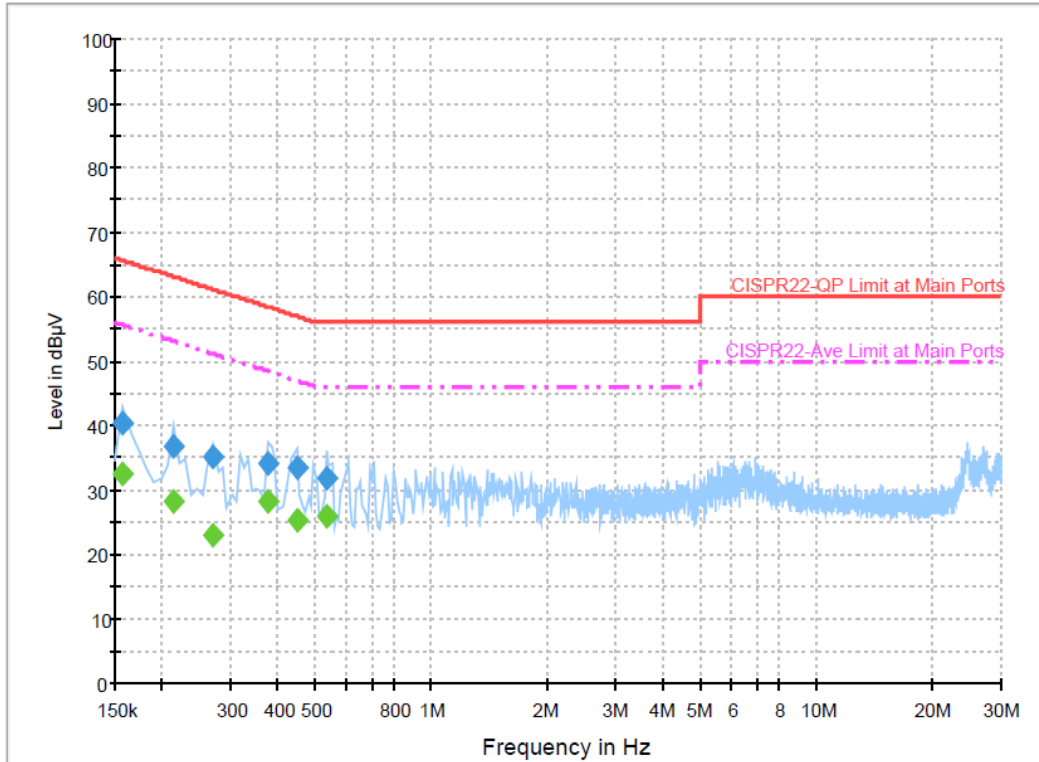

Final Result 1

Frequency (MHz)	QuasiPeak (dBµV)	Filter	Line	Corr. (dB)	Margin (dB)	Limit (dBµV)
0.158000	40.4	Off	N	19.4	25.2	65.6
0.214000	36.9	Off	N	19.4	26.1	63.0
0.270000	35.0	Off	N	19.3	26.1	61.1
0.374000	34.1	Off	N	19.4	24.3	58.4
0.446000	33.5	Off	N	19.3	23.4	56.9
0.534000	31.9	Off	N	19.3	24.1	56.0

Final Result 2

Frequency (MHz)	Average (dBµV)	Filter	Line	Corr. (dB)	Margin (dB)	Limit (dBµV)
0.158000	32.5	Off	N	19.4	23.1	55.6
0.214000	28.2	Off	N	19.4	24.8	53.0
0.270000	23.0	Off	N	19.3	28.1	51.1
0.374000	28.1	Off	N	19.4	20.3	48.4
0.446000	25.4	Off	N	19.3	21.5	46.9
0.534000	26.0	Off	N	19.3	20.0	46.0

3.9 Radiated Emission Measurement

3.9.1 Limit of Radiated Emission

In any 100 kHz bandwidth outside the intentional radiator frequency band, all harmonics/spurious must be at least 20 dB below the highest emission level within the authorized band. In addition, radiated emissions which fall in the restricted bands must also comply with the FCC section 15.209 limits as below.

Frequency (MHz)	Field Strength (microvolts/meter)	Measurement Distance (meters)
0.009 – 0.490	2400/F(kHz)	300
0.490 – 1.705	24000/F(kHz)	30
1.705 – 30.0	30	30
30 – 88	100	3
88 – 216	150	3
216 - 960	200	3
Above 960	500	3

3.9.2 Measuring Instruments

See list of measuring instruments of this test report.

3.9.3 Test Procedures

1. The testing follows the guidelines in FCC Public Notice DA 00-705 Measurement Guidelines.
2. Use the following spectrum analyzer settings:
Span = wide enough to fully capture the emission being measured; RBW = 1 MHz for $f \geq 1$ GHz, 100 kHz for $f < 1$ GHz; VBW \geq RBW; Sweep = auto; Detector function = peak; Trace = max hold.
3. Follow the guidelines in ANSI C63.4-2003 with respect to maximizing the emission by rotating the EUT, measuring the emission for three EUT orthogonal planes, and adjusting the measurement antenna height and polarization. A pre-amp and a high pass filter are used for this test in order to get the good signal level.

3.9.4 Test Setup

For radiated emissions below 30MHz

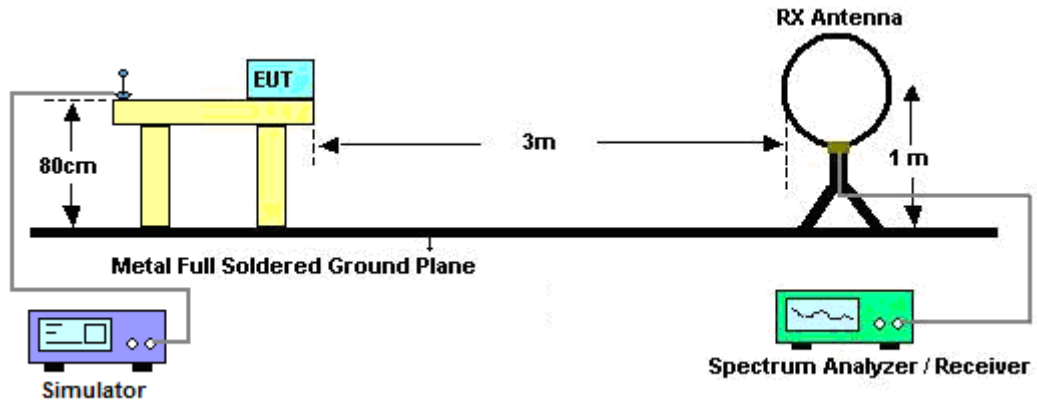

For radiated emissions above 30MHz

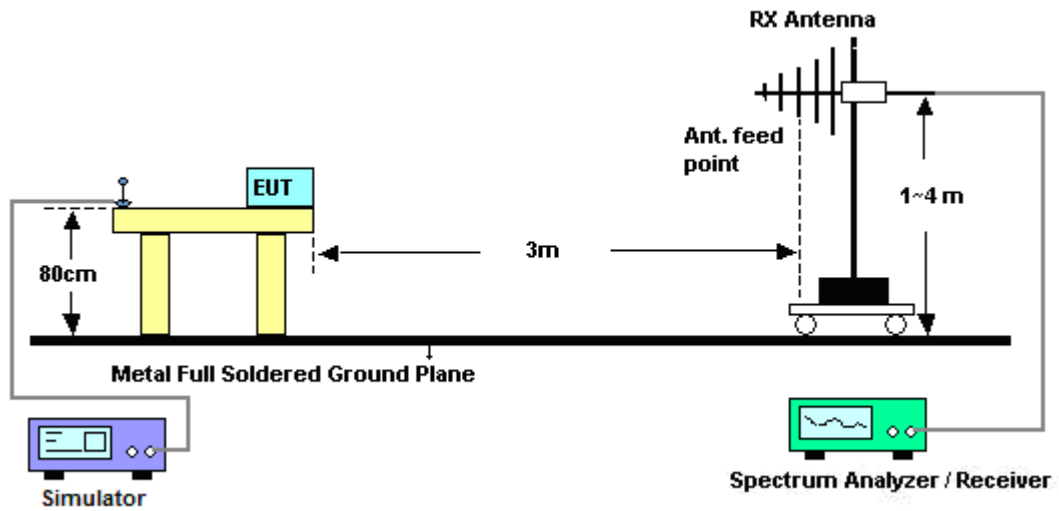



3.9.5 Test Results of Radiated Emissions (9 kHz ~ 30 MHz)

Test Engineer :	Elvis Chen	Temperature :	21~23°C	
		Relative Humidity :	44~46%	
Frequency (MHz)	Level (dBuV)	Over Limit (dB)	Limit Line (dBuV)	Remark
-	-	-	-	See Note

Note:

The amplitude of spurious emissions that are attenuated by more than 20dB below the permissible value has no need to be reported.

Distance extrapolation factor = $40 \log(\text{specific distance} / \text{test distance})$ (dB);

Limit line = specific limits (dBuV) + distance extrapolation factor.



3.9.6 Test Result of Radiated Emission (30 MHz ~ 10th Harmonic)

Test Mode :	Mode 1	Temperature :	21~23°C
Test Channel :	00	Relative Humidity :	44~46%
Test Engineer :	Elvis Chen	Polarization :	Horizontal
Remark :	2402 MHz is Fundamental Signals which can be ignored.		

Frequency (MHz)	Level (dBuV/m)	Over Limit (dB)	Limit Line (dBuV/m)	Read Level (dBuV)	Antenna Factor (dB)	Cable Loss (dB)	Preamp Factor (dB)	Ant Pos (cm)	Table Pos (deg)	Remark
66.18	18.83	-21.17	40	42.59	6.52	1.29	31.57	-	-	Peak
119.1	18.38	-25.12	43.5	36.67	11.5	1.76	31.55	-	-	Peak
299.73	24.63	-21.37	46	39.98	13.11	3.01	31.47	-	-	Peak
399.4	26.43	-19.57	46	38.7	15.66	3.53	31.46	-	-	Peak
614.3	24	-22	46	32.41	18.79	4.48	31.68	-	-	Peak
957.3	27.96	-18.04	46	31.96	20.96	5.59	30.55	100	174	Peak
2369.09	35.67	-18.33	54	34.35	31.83	3.89	34.4	104	356	Average
2369.09	46.2	-27.8	74	44.88	31.83	3.89	34.4	104	356	Peak
2402	97.33	-	-	95.92	31.88	3.92	34.39	104	356	Peak
2402	80.09	-	-	78.7	31.86	3.92	34.39	104	356	Average
2486	31.54	-22.46	54	29.88	31.98	4.05	34.37	104	356	Average
2486	44.21	-29.79	74	42.55	31.98	4.05	34.37	104	356	Peak
8841	53.2	-20.8	74	43.99	35.97	7.62	34.38	100	101	Peak
8841	40.71	-13.29	54	31.5	35.97	7.62	34.38	100	101	Average



Test Mode :	Mode 1	Temperature :	21~23°C
Test Channel :	00	Relative Humidity :	44~46%
Test Engineer :	Elvis Chen	Polarization :	Vertical
Remark :	2402 MHz is Fundamental Signals which can be ignored.		

Frequency (MHz)	Level (dBuV/m)	Over Limit (dB)	Limit Line (dBuV/m)	Read Level (dBuV)	Antenna Factor (dB)	Cable Loss (dB)	Preamp Factor (dB)	Ant Pos (cm)	Table Pos (deg)	Remark
33.78	28.85	-11.15	40	43.17	16.41	0.89	31.62	100	89	Peak
66.99	21.19	-18.81	40	44.91	6.54	1.3	31.56	-	-	Peak
152.58	14.94	-28.56	43.5	34.04	10.26	2.03	31.39	-	-	Peak
399.4	22.47	-23.53	46	34.74	15.66	3.53	31.46	-	-	Peak
659.8	24.84	-21.16	46	32.85	19.03	4.59	31.63	-	-	Peak
894.3	26.77	-19.23	46	31.62	20.69	5.44	30.98	-	-	Peak
2337.17	34.75	-19.25	54	33.52	31.78	3.86	34.41	100	308	Average
2337.17	46.04	-27.96	74	44.81	31.78	3.86	34.41	100	308	Peak
2402	94.25	-	-	92.84	31.88	3.92	34.39	100	308	Peak
2402	77.84	-	-	76.45	31.86	3.92	34.39	100	308	Average
2492	31.57	-22.43	54	29.89	32	4.05	34.37	100	308	Average
2492	44.47	-29.53	74	42.79	32	4.05	34.37	100	308	Peak
8730	53.34	-20.66	74	44.24	35.89	7.48	34.27	100	63	Peak
8730	41.45	-12.55	54	32.35	35.89	7.48	34.27	100	63	Average



Test Mode :	Mode 2	Temperature :	21~23°C
Test Channel :	39	Relative Humidity :	44~46%
Test Engineer :	Elvis Chen	Polarization :	Horizontal
Remark :	2441 MHz is Fundamental Signals which can be ignored.		

Frequency (MHz)	Level (dBuV/m)	Over Limit (dB)	Limit Line (dBuV/m)	Read Level (dBuV)	Antenna Factor (dB)	Cable Loss (dB)	Preamp Factor (dB)	Ant Pos (cm)	Table Pos (deg)	Remark
30	17.98	-22.02	40	30.32	18.51	0.83	31.68	-	-	Peak
154.74	15.51	-27.99	43.5	34.67	10.19	2.06	31.41	-	-	Peak
299.73	19.19	-26.81	46	34.54	13.11	3.01	31.47	-	-	Peak
399.4	27.95	-18.05	46	40.22	15.66	3.53	31.46	100	196	Peak
822.9	25.73	-20.27	46	31.66	20.22	5.2	31.35	-	-	Peak
943.3	26.97	-19.03	46	31.15	20.91	5.55	30.64	-	-	Peak
2374	44.08	-29.92	74	42.76	31.83	3.89	34.4	102	355	Peak
2374	33.77	-20.23	54	32.45	31.83	3.89	34.4	102	355	Average
2441	98.79	-	-	97.25	31.93	3.99	34.38	102	355	Peak
2441	81.69	-	-	80.15	31.93	3.99	34.38	102	355	Average
2500	31.61	-22.39	54	29.93	32	4.05	34.37	102	355	Average
2500	44.07	-29.93	74	42.39	32	4.05	34.37	102	355	Peak
8766	53.45	-20.55	74	44.33	35.91	7.53	34.32	100	28	Peak
8766	42.07	-11.93	54	32.95	35.91	7.53	34.32	100	28	Average



Test Mode :	Mode 2	Temperature :	21~23°C
Test Channel :	39	Relative Humidity :	44~46%
Test Engineer :	Elvis Chen	Polarization :	Vertical
Remark :	2441 MHz is Fundamental Signals which can be ignored.		

Frequency (MHz)	Level (dBuV/m)	Over Limit (dB)	Limit Line (dBuV/m)	Read Level (dBuV)	Antenna Factor (dB)	Cable Loss (dB)	Preamp Factor (dB)	Ant Pos (cm)	Table Pos (deg)	Remark
33.24	29.53	-10.47	40	43.35	16.93	0.88	31.63	100	221	Peak
49.98	21.87	-18.13	40	41.09	11.28	1.12	31.62	-	-	Peak
68.34	21.21	-18.79	40	44.87	6.57	1.32	31.55	-	-	Peak
399.4	23.61	-22.39	46	35.88	15.66	3.53	31.46	-	-	Peak
796.3	25.43	-20.57	46	31.79	20.04	5.1	31.5	-	-	Peak
917.4	26.82	-19.18	46	31.35	20.8	5.5	30.83	-	-	Peak
2310	44.9	-29.1	74	43.76	31.73	3.82	34.41	100	313	Peak
2310	32.81	-21.19	54	31.67	31.73	3.82	34.41	100	313	Average
2441	91.83	-	-	90.29	31.93	3.99	34.38	100	313	Peak
2441	76.83	-	-	75.29	31.93	3.99	34.38	100	313	Average
2500	31.53	-22.47	54	29.85	32	4.05	34.37	100	313	Average
2500	43.65	-30.35	74	41.97	32	4.05	34.37	100	313	Peak
8802	53.16	-20.84	74	44	35.94	7.56	34.34	100	88	Peak
8802	41.05	-12.95	54	31.89	35.94	7.56	34.34	100	88	Average



Test Mode :	Mode 3	Temperature :	21~23°C
Test Channel :	78	Relative Humidity :	44~46%
Test Engineer :	Elvis Chen	Polarization :	Horizontal
Remark :	2480 MHz is Fundamental Signals which can be ignored.		

Frequency (MHz)	Level (dBuV/m)	Over Limit (dB)	Limit Line (dBuV/m)	Read Level (dBuV)	Antenna Factor (dB)	Cable Loss (dB)	Preamp Factor (dB)	Ant Pos (cm)	Table Pos (deg)	Remark
31.08	18.63	-21.37	40	31.46	17.98	0.85	31.66	-	-	Peak
64.83	16.52	-23.48	40	40.3	6.51	1.28	31.57	-	-	Peak
153.93	15.33	-28.17	43.5	34.47	10.21	2.05	31.4	-	-	Peak
399.4	26.64	-19.36	46	38.91	15.66	3.53	31.46	-	-	Peak
631.8	23.22	-22.78	46	31.47	18.88	4.52	31.65	-	-	Peak
899.9	26.72	-19.28	46	31.48	20.73	5.46	30.95	100	69	Peak
2366	44.46	-29.54	74	43.16	31.81	3.89	34.4	183	9	Peak
2366	32.45	-21.55	54	31.15	31.81	3.89	34.4	183	9	Average
2480	101.44	-	-	99.78	31.98	4.05	34.37	183	9	Peak
2480	83.66	-	-	82	31.98	4.05	34.37	183	9	Average
2483.5	65.27	-8.73	74	63.61	31.98	4.05	34.37	183	9	Peak
2483.5	25.99	-28.01	54	24.33	31.98	4.05	34.37	183	9	Average
8742	53.18	-20.82	74	44.09	35.89	7.5	34.3	100	2	Peak
8742	41.95	-12.05	54	32.86	35.89	7.5	34.3	100	2	Average



Test Mode :	Mode 3	Temperature :	21~23°C
Test Channel :	78	Relative Humidity :	44~46%
Test Engineer :	Elvis Chen	Polarization :	Vertical
Remark :	2480 MHz is Fundamental Signals which can be ignored.		

Frequency (MHz)	Level (dBuV/m)	Over Limit (dB)	Limit Line (dBuV/m)	Read Level (dBuV)	Antenna Factor (dB)	Cable Loss (dB)	Preamp Factor (dB)	Ant Pos (cm)	Table Pos (deg)	Remark
33.24	28.55	-11.45	40	42.37	16.93	0.88	31.63	100	99	Peak
49.44	21.89	-18.11	40	41.31	11.09	1.11	31.62	-	-	Peak
67.53	21.1	-18.9	40	44.79	6.56	1.31	31.56	-	-	Peak
458.9	20.37	-25.63	46	31.35	16.73	3.79	31.5	-	-	Peak
631.8	23.97	-22.03	46	32.22	18.88	4.52	31.65	-	-	Peak
957.3	27.17	-18.83	46	31.17	20.96	5.59	30.55	-	-	Peak
2350	44.2	-29.8	74	42.97	31.78	3.86	34.41	100	266	Peak
2350	33.14	-20.86	54	31.91	31.78	3.86	34.41	100	266	Average
2480	93.92	-	-	92.26	31.98	4.05	34.37	100	266	Peak
2480	77.54	-	-	75.88	31.98	4.05	34.37	100	266	Average
2483.5	58.44	-15.56	74	56.78	31.98	4.05	34.37	100	266	Peak
2483.5	25.7	-28.3	54	24.04	31.98	4.05	34.37	100	266	Average
8721	53.81	-20.19	74	44.73	35.87	7.48	34.27	100	105	Peak
8721	41.38	-12.62	54	32.3	35.87	7.48	34.27	100	105	Average



3.10 Antenna Requirements

3.10.1 Standard Applicable

If directional gain of transmitting antennas is greater than 6dBi, the power shall be reduced by the same level in dB comparing to gain minus 6dBi. The use of a permanently attached antenna or of an antenna that uses a unique coupling to the intentional radiator shall be considered sufficient to comply with the FCC rule.

3.10.2 Antenna Connected Construction

The antennas type used in this product is PIFA Antenna without connector and it is considered to meet antenna requirement.

3.10.3 Antenna Gain

The antenna peak gain of EUT is less than 6 dBi. Therefore, it is not necessary to reduce maximum peak output power limit.



4 List of Measuring Equipment

Instrument	Manufacturer	Model No.	Serial No.	Characteristics	Calibration Date	Due Date	Remark
Spectrum Analyzer	R&S	FSP40	100055	9kHz~40GHz	Jun. 23, 2009	Jun. 22, 2010	Conducted (TH02-HY)
Power Meter	Anritsu	ML2495A	0932001	N/A	Sep. 17, 2009	Sep. 16, 2010	Conducted (TH02-HY)
Power Sensor	Anritsu	MA2411B	0846202	N/A	Sep. 10, 2009	Sep. 09, 2010	Conducted (TH02-HY)
Spectrum Analyzer	Agilent	E4408B	MY44211030	9KHz-26.5GHz	Oct. 23, 2009	Oct. 22, 2010	Radiation (03CH06-HY)
Spectrum Analyzer	R&S	FSP40	100057	9KHz-40GHz	Oct. 20, 2009	Oct. 19, 2010	Radiation (03CH06-HY)
EMI Test Receiver	R&S	ESVS10	834468/003	20MHz-1000MHz	Apr. 28, 2010	Apr. 27, 2011	Radiation (03CH06-HY)
Bilog Antenna	SCHAFFNER	CBL6112B	2885	30MHz -2GHz	Oct. 31, 2009	Oct. 30, 2010	Radiation (03CH06-HY)
Double Ridge Horn Antenna	EMCO	3117	00066583	1GHz~18GHz	Aug. 20, 2009	Aug. 19, 2010	Radiation (03CH06-HY)
Double Ridge Horn Antenna	Training Research	AH-0801	95119	8GHz~18GHz	Nov. 02, 2009	Nov. 01, 2010	Radiation (03CH06-HY)
SHF-EHF Horn Antenna	SCHWARZBECK	BBHA 9170	BBHA9170251	15GHz- 40GHz	Oct. 14, 2009	Oct. 13, 2010	Radiation (03CH06-HY)
Pre Amplifier	Agilent	8449B	3008A01917	1GHz- 26.5GHz	Nov. 11, 2009	Nov. 10, 2010	Radiation (03CH06-HY)
Amplifier	Agilent	310N	186713	9KHz~1GHz	Apr. 15, 2010	Apr. 14, 2011	Radiation (03CH06-HY)
Bluetooth Base Station	R&S	CBT32	100519	N/A	May 12, 2009	May 11, 2011	-

5 Uncertainty of Evaluation

Uncertainty of Radiated Emission Measurement (30 MHz ~ 1000 MHz)

Contribution	Uncertainty of X_i		$u(X_i)$
	dB	Probability Distribution	
Receiver Reading	0.41	Normal (k=2)	0.21
Antenna Factor Calibration	0.83	Normal (k=2)	0.42
Cable Loss Calibration	0.25	Normal (k=2)	0.13
Pre-Amplifier Gain Calibration	0.27	Normal (k=2)	0.14
RCV/SPA Specification	2.50	Rectangular	0.72
Antenna Factor Interpolation for Frequency	1.00	Rectangular	0.29
Site Imperfection	1.43	Rectangular	0.83
Mismatch	+0.39 / -0.41	U-Shape	0.28
Combined Standard Uncertainty $U_c(y)$	1.27		
Measuring Uncertainty for a Level of Confidence of 95% ($U = 2U_c(y)$)	2.54		

Uncertainty of Radiated Emission Measurement (1 GHz ~ 40 GHz)

Contribution	Uncertainty of X_i		$u(X_i)$	C_i	$C_i * u(X_i)$
	dB	Probability Distribution			
Receiver Reading	± 0.10	Normal (k=2)	0.10	1	0.10
Antenna Factor Calibration	± 1.70	Normal (k=2)	0.85	1	0.85
Cable Loss Calibration	± 0.50	Normal (k=2)	0.25	1	0.25
Receiver Correction	± 2.00	Rectangular	1.15	1	1.15
Antenna Factor Directional	± 1.50	Rectangular	0.87	1	0.87
Site Imperfection	± 2.80	Triangular	1.14	1	1.14
Mismatch Receiver VSWR $\Gamma_1 = 0.197$ Antenna VSWR $\Gamma_2 = 0.194$ Uncertainty = $20\text{Log}(1-\Gamma_1*\Gamma_2)$	+0.34 / -0.35	U-Shape	0.244	1	0.244
Combined Standard Uncertainty $U_c(y)$	2.36				
Measuring Uncertainty for a Level of Confidence of 95% ($U = 2U_c(y)$)	4.72				

6 Certification of TAF Accreditation



Certificate No. : L1190-100107

財團法人全國認證基金會
Taiwan Accreditation Foundation

Certificate of Accreditation

This is to certify that

Sporton International Inc.
EMC & Wireless Communications Laboratory
No.52, Hwa Ya 1st Rd., Hwa Ya Technology Park, Kwei-Shan Hsiang, Tao Yuan Hsien,
Taiwan, R.O.C.

is accredited in respect of laboratory

Accreditation Criteria	: ISO/IEC 17025:2005
Accreditation Number	: 1190
Originally Accredited	: December 15, 2003
Effective Period	: January 10, 2010 to January 09, 2013
Accredited Scope	: Testing Field, see described in the Appendix
Specific Accreditation Program	: Accreditation Program for Designated Testing Laboratory for Commodities Inspection Accreditation Program for Telecommunication Equipment Testing Laboratory Accreditation Program for BSMI Mutual Recognition Arrangement with Foreign Authorities

Jay-san Chen

Jay-San Chen
President, Taiwan Accreditation Foundation
Date : January 07, 2010

P1, total 21 pages

The Appendix forms an integral part of this Certificate, which shall be invalid when use without the Appendix



Appendix A. Photographs of EUT

Please refer to Sporton report number EP981906-16 as below.