

FCC Dynamic Frequency Selection Test Report

for

Acer Incorporated

Notebook Computer

N24G4

acer; Gateway

FCC ID: HLZN24G4

Prepared for : Acer Incorporated

8F., No.88, Sec. 1, Xintai 5th Rd., Xizhi Dist., New Taipei  
City 221 Taiwan

Prepared By : Audix Technology (Shenzhen) Co., Ltd.

No. 6, Kefeng Road, Science & Technology Park,  
Nanshan District , Shenzhen, Guangdong, China

Tel: (0755) 26639496

Report Number : ACS-F25047

Date of Test : Mar.06, 2025

Date of Report : Mar.18, 2025

## TABLE OF CONTENTS

<u>Description</u>	<u>Page</u>
TEST REPORT VERIFICATION.....	3
1.SUMMARY OF MEASUREMENTS AND RESULTS .....	4
2.GENERAL INFORMATION .....	5
2.1.Description of Device (EUT) .....	5
2.2.Feature of Equipment Under Test .....	6
2.3.Support Equipment.....	8
2.4.Test Channel.....	8
2.5.Description of Test Facility .....	9
2.6.Measurement Uncertainty .....	9
3.TEST EQUIPMENT .....	10
4.WORKING MODES AND REQUIREMENT TEST ITEM.....	11
4.1.Applicability of DFS Requirements Prior To Use A Channel .....	11
4.2.Applicability of DFS Requirements During Normal Operation.....	11
5.DFS DETECTION THRESHOLOLOS AND RADAR TEST WAVEFORMS .....	12
5.1.Interference Threshold Value, Master or Client Incorporating In-Service Monitoring .....	12
5.2.Radar Test Waveform Minimum Step .....	12
5.3.Short Pulse Radar Test Waveforms.....	13
5.4.Long Pulse Radar Test Waveforms.....	14
5.5.Frequency Hopping Pulse Radar Test Waveforms .....	16
5.6.Conducted Calibration Setup .....	18
5.7.Radar Waveform Calibration Procedure .....	18
5.8.Calibration Deviation .....	18
5.9.Radar Waveform Calibration Result .....	19
6.TEST SETUP AND TEST RESULT.....	20
6.1.Test Setup.....	20
6.2.Channel Move Time, Channel Closing Time, Non-Occupancy Period Measurement.....	22
7.PHOTOGRAPHS OF MEASUREMENT .....	26
7.1.Photographs of Slave Mode .....	26
8.PHOTOS OF THE EUT .....	27

## TEST REPORT VERIFICATION

Applicant : Acer Incorporated  
Manufacturer : Acer Incorporated  
Product : Notebook Computer  
FCC ID : HLZN24G4  
(A) Model No. : N24G4  
(B) Brand : acer; Gateway  
(C) Test Voltage : AC 120V/60Hz

Measurement Standards Used:

FCC RULES AND REGULATIONS PART 15 Subpart E  
(FCC CFR 47 Part 15E, §15.407)

The device described above was tested by Audix Technology (Shenzhen) Co., Ltd. to determine the maximum emission levels emanating from the device. The maximum emission levels were compared to the FCC Part 15 subpart E limits.

The measurement results are contained in this test report and Audix Technology (Shenzhen) Co., Ltd. is assumed full responsibility for the accuracy and completeness of these measurements. Also, this report shows that the EUT to be technically compliant with the requirements of FCC Part 15E standards.

This report applies to single evaluation of one sample of above mentioned product. This report shall not be reproduced in part without written approval of Audix Technology (Shenzhen) Co., Ltd.

Date of Test : Mar.06, 2025 Date of Report: Mar.18, 2025

Prepared by : Jasmine Ning Reviewed by : Thomas Chen  
Jasmine Ning / Assistant Thomas Chen / Assistant Manager



Approved & Authorized Signer : Signature: Sunny Lu  
Sunny Lu / Manager

## 1. SUMMARY OF MEASUREMENTS AND RESULTS

The EUT has been tested according to the applicable standards as referenced below.

Description of Test Item	Results
Channel Availability Check Time	N/A
Channel Move Time	PASS
Non-Occupancy Period	N/A
Channel Closing Transmission Time	PASS
U-NII Detection Bandwidth	N/A

Note: 1. Measurement uncertainty affection to the result is not considered, the EUT is technically compliant with standard requirements.

2. N/A is an abbreviation for Not Applicable, sine the product is client without radar detection function

## 2. GENERAL INFORMATION

### 2.1. Description of Device (EUT)

Applicant	Acer Incorporated
Applicant Address	8F., No.88, Sec. 1, Xintai 5th Rd., Xizhi Dist., New Taipei City 221 Taiwan
Manufacturer	Acer Incorporated
Manufacturer Address	8F., No.88, Sec. 1, Xintai 5th Rd., Xizhi Dist., New Taipei City 221 Taiwan
Brand	acer; Gateway
Product	Notebook Computer
Model No.	N24G4
FCC ID	HLZN24G4
Sample Type	Prototype production
Date of Receipt	Feb.13, 2025
Date of Test	Mar.06, 2025

2.2. Feature of Equipment Under Test

Product Feature & Specification		
Product	Notebook Computer	
Model No.	F25047	
Power Source	<input checked="" type="checkbox"/> Commercial Power	AC 100-240V,50/60Hz ,1.5A
	<input checked="" type="checkbox"/> External Power Source	DC 19V, 2.7A
	<input type="checkbox"/> Lithium battery	DC V, mAh
	<input type="checkbox"/> UM battery	DC V
Bluetooth		
Radio	BDR +EDR; BLE	
Frequency Range	2402-2480MHz	
Type of Modulation	GFSK, $\pi/4$ DQPSK, 8DPSK	
Data Rate	1Mbps, 2Mbps, 3Mbps	
Quantity of Channels	79/40	
Channel Separation	1MHz	
2.4GHz Wi-Fi		
Support Modes	802.11b/g/n20/n40	
Frequency Range	2412-2462MHz	
Type of Modulation	802.11b(DSSS): CCK, QPSK, BPSK; 802.11g/n(OFDM): 64QAM,16QAM, QPSK, BPSK	
Data Rate	802.11b: 1/2/5.5/11 Mbps; 802.11g: 6/9/12/18/24/36/48/54 Mbps; 802.11n: up to 300Mbps	
Channel Separation	5MHz	
5GHz Wi-Fi		
Support Modes	802.11a/n20/n40/ac20/ac40/ac80	
Frequency Range	5180-5240MHz, 5500-5700MHz, 5260-5320MHz, 5745-5825MHz	
Type of Modulation	802.11a/n (OFDM): QPSK, BPSK, 16QAM, 64QAM 802.11ac (OFDM): QPSK, BPSK, 16QAM, 64QAM,256QAM	
Data Rate	802.11a: 6/9/12/18/24/36/48/54 Mbps; 802.11n: up to 300Mbps; 802.11ac: up to 867Mbps;	
Channel Separation	5MHz	

Antenna System	
Type of Antenna	PIFA Antenna
Antenna Number	1
Antenna Peak Gain	Bluetooth Peak Gain: 2.43dBi WIFI 2.4G Peak Gain: 2.43dBi U-NII Band Peak Gain: 2.38dBi
Remark: This report is for DFS only. EUT also supports other radio specification as below listed: BDR+EDR (Test report No. ACS-F25043) BLE (Test report No. ACS-F25044) WiFi 2.4GHz (Test report No. ACS-F25045) WiFi 5GHz (Test report No. ACS-F25046) SAR (Test report No. ACS-SF25004) DFS (Test report No. ACS-F25047)	

### 2.3. Support Equipment

Item	Manufacturer	Model	Remark
AP Server	CISCO	AIR-AP1262N-A-K9	FCC ID: LDK102073 IC:2461B-102073
AP Server	D-Link	DIR-815A1	NCC ID: CCAI10LP092AT0 FCC ID: KA2IR815A1 IC: 4216A-IR815A1

### 2.4. Test Channel

Frequency Band	Channel No.	Frequency
5260-5320MHz (U-NII-2A Band)	<b>20MHz</b>	
	52	5260MHz
	<b>80MHz</b>	
	58	5290MHz
5500-5700MHz (U-NII-2C Band)	<b>20MHz</b>	
	100	5500MHz
	<b>80MHz</b>	
	106	5530MHz



## 2.5. Description of Test Facility

### Site Description

Name of Firm : Audix Technology (Shenzhen) Co., Ltd.  
No. 6, Kefeng Road, Science & Technology  
Park, Nanshan District, Shenzhen,  
Guangdong, China

### EMC Lab.

: Certificated by ISED, Canada  
Company Number: 5183A  
CAB identifier: CN0034  
Valid Date: Mar.31, 2025

: Accredited by NVLAP, USA  
NVLAP Code: 200372-0  
Valid Date: Mar.31, 2025

: Certificated by FCC, USA  
Designation No: CN5022  
Valid Date: Mar.31, 2025

## 2.6. Measurement Uncertainty

Test Item	Uncertainty
DFS Time Measurement	±3.2%
Threshold	±0.50dB

### 3. TEST EQUIPMENT

Item	Equipment	Manufacturer	Model No.	Serial No.	Last Cal.	Cal. Interval
1.	Vector Signal Generation	Rohde & Schwarz	SMU200A	105064	Sep.15,24	1 Year
2.	Signal Analyzer	Rohde & Schwarz	FSV30	104051	Mar.16,24	1 Year
3.	Test Software	Rohde & Schwarz	DFS Analysis Tool	1EF59_1E	N/A	N/A
4.	RF Cable	eastsheep	141-SMA-JJ-1000	NO.7	Jun.19,24	1 Year
5.	RF Cable	eastsheep	141-SMA-JJ-1000	NO.8	Jun.19,24	1 Year
6.	Attenuator(20dB)	MCL	VAT-20W2-2W	1527-001	Sep.15,24	1 Year
7.	Attenuator(20dB)	MCL	VAT-20W2-2W	1527-002	Sep.15,24	1 Year
8.	Attenuator(10dB)	Agilent	8491B	MY39269201	Mar.16,24	1 Year
9.	Power Splitter	Mini-Circuits	ZFRSC-183-S+	572806942	Sep.15,24	1 Year
10.	Power Splitter	Mini-Circuits	ZFRSC-183-S+	SF52501405	Sep.15,24	1 Year

Notes: N/A means Not applicable.

## 4. WORKING MODES AND REQUIREMENT TEST ITEM

### 4.1. Applicability of DFS Requirements Prior To Use A Channel

Requirement	Operational Mode		
	Master	Client without radar detection	Client with radar detection
Non-Occupancy Period	✓	✓	✓
DFS Detection Threshold	✓	Not required	✓
Channel Availability Check Time	✓	Not required	Not required
U-NII Detection Bandwidth	✓	Not required	✓

### 4.2. Applicability of DFS Requirements During Normal Operation

Requirement	Operational Mode		
	Master	Client without radar detection	Client with radar detection
DFS Detection Threshold	✓	Not required	✓
Channel Closing Transmission Time	✓	✓	✓
Channel Move Time	✓	✓	✓
U-NII Detection Bandwidth	✓	Not required	✓

## 5. DFS DETECTION THRESHOLOS AND RADAR TEST

### WAVEFORMS

#### 5.1. Interference Threshold Value, Master or Client Incorporating In-Service Monitoring

Maximum Transmit Power	Value (See Notes 1 and 2)
E.I.R.P. $\geq$ 200 milliwatt	-64dBm
E.I.R.P. $<$ 200 milliwatt Power spectral sensity $<$ 10dBm/MHz	-62dBm
E.I.R.P. $<$ 200 milliwatt that do not meet the power spectral sensity requirement	-64dBm

Note 1: This is the level at the input of the receiver assuming a 0 dBi receive antenna.

Note 2: Throughout these test procedures an additional 1 dB has been added to the amplitude of the test transmission waveforms to account for variations in measurement equipment. This will ensure that the test signal is at or above the detection threshold level to trigger a DFS response.

The radar Detection Threshold, lowest antenna gain is the parameter of interference radar DFS detection threshold.

#### 5.2. Radar Test Waveform Minimum Step

Step intervals of 0.1 microsecond for Pulse Width, 1 microsecond for PRI, 1MHz for chirp width and 1 for the number of pulses will be utilized for the random determination of specific test waveforms.

5.3. Short Pulse Radar Test Waveforms

Radar Type	Pulse Width (μsec)	PRI (μsec)	Number of Pulse	Minimum Percentage of Successful Detection	Minimum number of Trials
0	1	1428	18	See Note 1	See Note 1
1	1	Test A: 15 unique PRI values randomly selected from the list 23 PRI values in Table 5a	$\text{Roundup} \left\{ \begin{array}{l} \left( \frac{1}{360} \right) \\ \left( \frac{19 \cdot 10^6}{\text{PRI}_{\mu\text{sec}}} \right) \end{array} \right\}$	60%	30
		Test B: 15 unique PRI values randomly selected within the range of 518-3066 μsec, with a minimum increment of 1 μsec, excluding PRI values selected in Test A			
2	1-5	150-230	23-29	60%	30
3	6-10	200-500	16-18	60%	30
4	11-20	200-500	12-16	60%	30
Aggregate (Radar Types 1-4)				80%	120
<p><b>Note 1:</b> Short Pulse Radar Type 0 should be used for the detection bandwidth test, channel move time, and channel closing time tests.</p>					

A minimum of 30 unique waveforms are required for each of the short pulse radar type 2 through 4. If more than 30 waveforms are used for short pulse radar types 2 through 4, then each additional waveform must also be unique and not repeated from the previous waveforms. If more than 30 waveforms are used for short pulse radar types 1, then each additional waveform generated with Test B and must also be unique and not repeated from the previous waveforms in Tests A or B.

FCC Radar Types (1~4) System Diagram

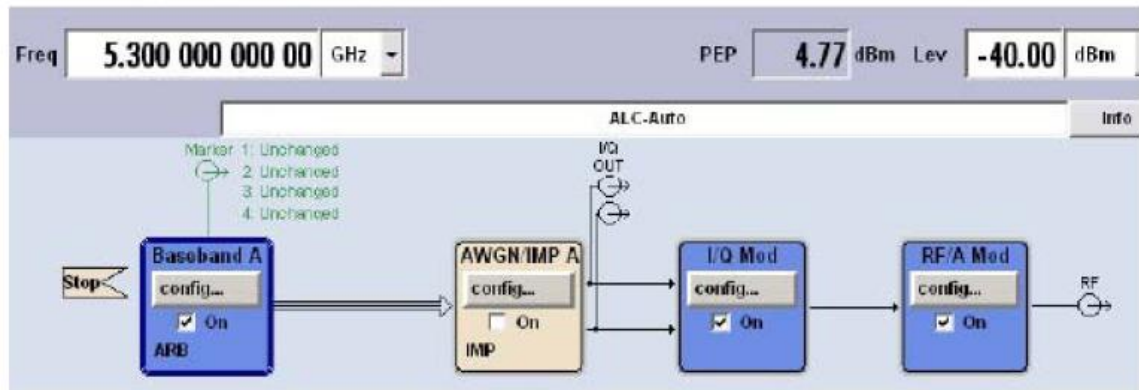

Used R&S SMU200A (Vector SG with two ARB)

B11: Base-band Generator with ARB (16M samples) and Digital Modulation

B13: Base-band Main Module

B106: frequency range (100 kHz to 6 GHz)

For selecting the waveform parameters from within the bounds of the signal type, system was random selection using uniform distribution.

#### 5.4. Long Pulse Radar Test Waveforms

Radar Type	Pulse Width (µsec)	Chirp Width (MHz)	PRI (µsec)	Number of Pulse Per Burst	Number of Bursts	Minimum Percentage of Successful Detection	Minimum of Trials
5	50-100	5-20	1000-2000	1-3	8-20	80%	30

The parameters for this waveform are randomly chosen. Thirty unique waveforms are required for the Long Pulse radar test signal. If more 30 waveforms are used for the Long Pulse radar test signal, then each additional waveform must also be unique and not repeated from the previous waveforms. Each waveform is defined as following:

- (1) The transmission period for the Long Pulse Radar test signal is 12 seconds.
- (2) There are a total of 8 to 20 Bursts in the 12 second period, with the number of Bursts being randomly chosen. This number is Burst\_Count.
- (3) Each Burst consists of 1 to 3 pulses, with the number of pulses being randomly chosen. Each Burst within the 12 second sequence may have a different number of pulses.
- (4) The pulse width is between 50 and 100 microseconds, with the pulse width being randomly chosen. Each pulse within a Burst will have the same pulse width. Pulses in different Bursts may have different pulse widths.
- (5) Each pulse has a linear FM chirp between 5 and 20MHz, with the chirp width being randomly chosen. Each pulse within a Burst will have the same chirp width. Pulses in different Burst may have different chirp widths. The chirp is centered on the pulse. For example, with a radar frequency of 5300MHz and a 20MHz chirped signal, the chirp starts at 5290MHz and ends at 5310MHz.

- (6) If more than one pulse is present in a Burst, the time between the pulses will be between 1000 and 2000 microseconds, with the time being randomly chosen. If three pulses are present in a Burst, the time between the first and second pulses is chosen independently of the time between the second and third pulses.
- (7) The 12 second transmission period is divided into even intervals. The number of intervals is equal to Burst\_Count. Each interval is of length  $(12000000/\text{Burst\_Count})$  microseconds. Each interval contains one Burst. The start time for the Burst, relative to the beginning of the interval, is between 1 and  $[(12000000/\text{Burst\_Count})-(\text{Total Burst length})+(\text{One Random PRI interval})]$  microseconds, with the start time being randomly chosen. The step interval for the start time is 1 microsecond. The start time for each Burst is chosen independently.

A representative example of a Long Pulse radar test waveform:

- (1) The total test signal length is 12 seconds.
- (2) 8 Bursts are randomly generated for the Burst\_Count.
- (3) Burst 1 has 2 randomly generated pulses.
- (4) The pulse width (for both pulses) is randomly selected to be 75 microseconds.
- (5) The PRI is randomly selected to be at 1213 microseconds.
- (6) Bursts 2 through 8 are generated using steps 3-5.
- (7) Each Burst is contained in even intervals of 1500000 microseconds. The starting location for Pulse 1. Burst 1 is randomly generated (1 to 1500000 minus the total Burst 1 length + 1 random PRI interval) at the 325001 microsecond step. Bursts 2 through 8 randomly fall in successive 1500000 microsecond intervals (i.e. Burst 2 falls in the 1500001-3000000 microsecond range).

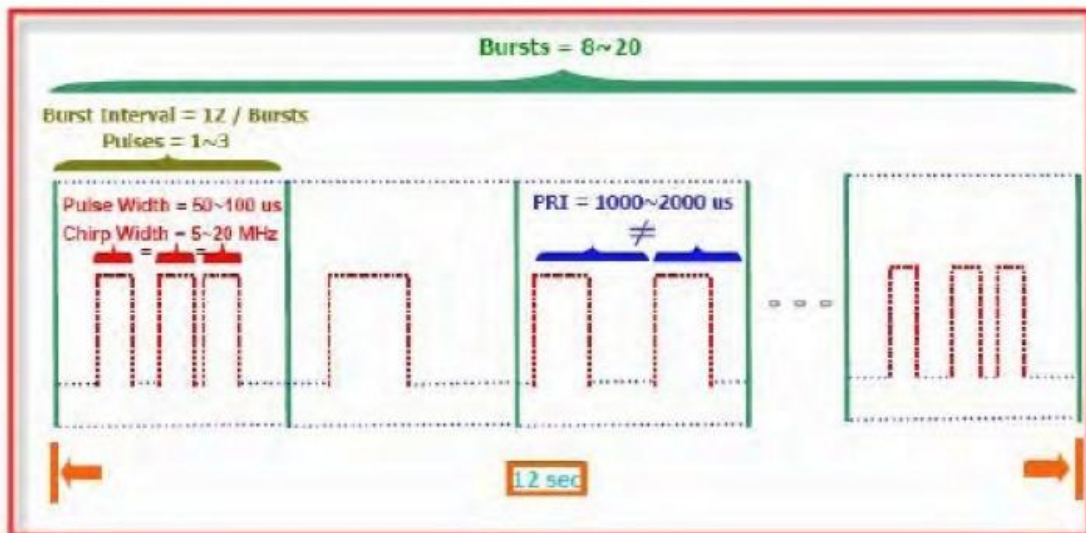

FCC Radar Types (5) System Diagram

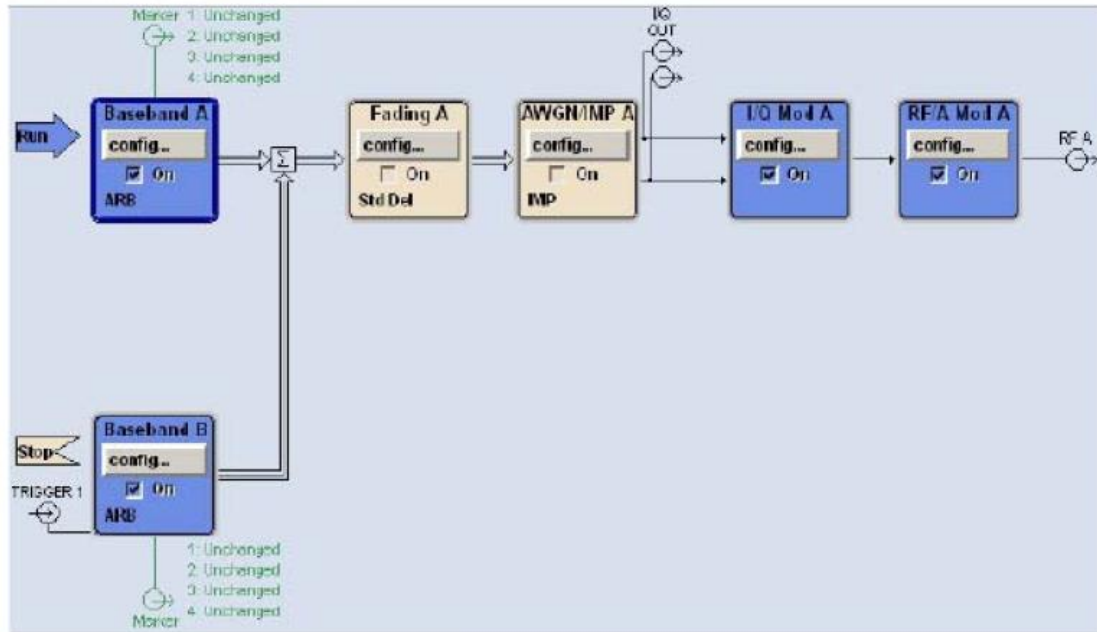

Used R&S SMU200A (Vector SG with two ARB)

Path A/Path B Two B11: Base-band Generator with ARB (16M samples) and Digital Modulation

B13: Base-band Main Module

B106: frequency range (100 kHz to 6 GHz)

For selecting the waveform parameters from within the bounds of the signal type, system was random selection using uniform distribution.

### 5.5. Frequency Hopping Pulse Radar Test Waveforms

Radar Type	Pulse Width (μsec)	PRI (μsec)	Pulses Per Hop	Hopping Rate (kHz)	Hopping Sequence Length (ms)	Minimum Percentage of Successful Detection	Minimum of Trials
6	1	333	9	0.333	300	70%	30

For the Frequency Hopping Radar Type, the same Burst parameters are used for each waveform. The hopping sequence is different for each waveform and a 100-length segment is selected from the hopping sequence defined by the following algorithm: The first frequency in a hopping sequence is selected randomly from the group of 475 integer frequencies from 5250-5274MHz. Next, the frequency that was just chosen is removed from the group and a frequency is randomly selected from the remaining 474 frequencies in the group. This process continues until all 475 frequencies are chosen for the set. For selection of random frequency, the frequencies remaining within the group are always treated as equally likely.



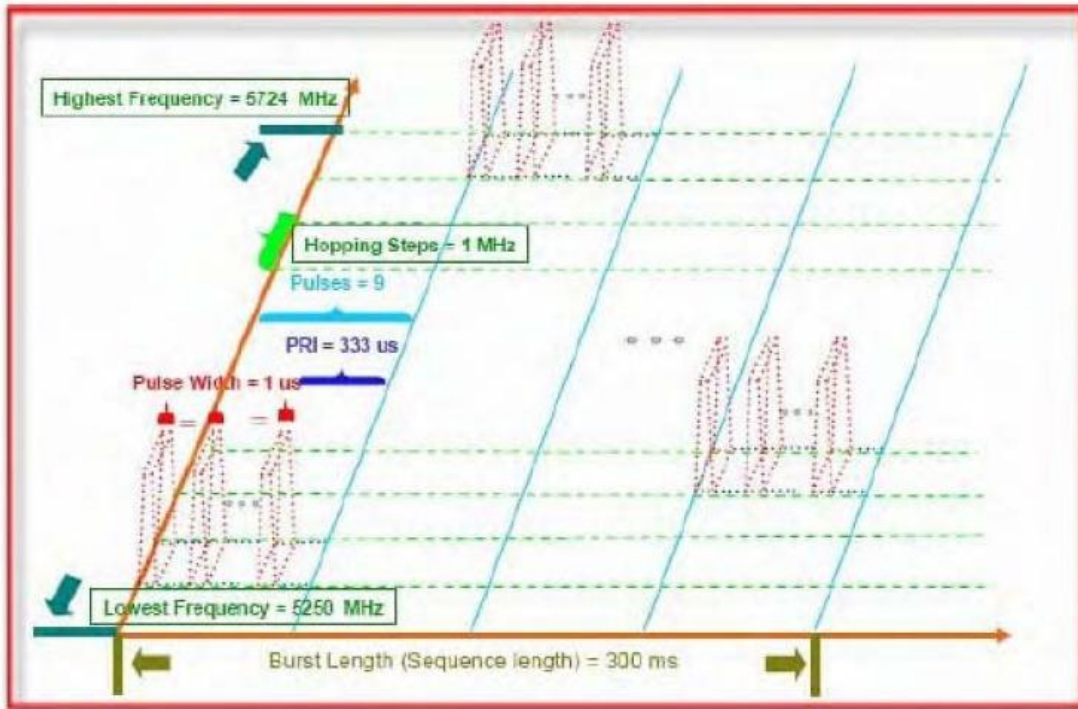

FCC Radar Types (6) System Diagram

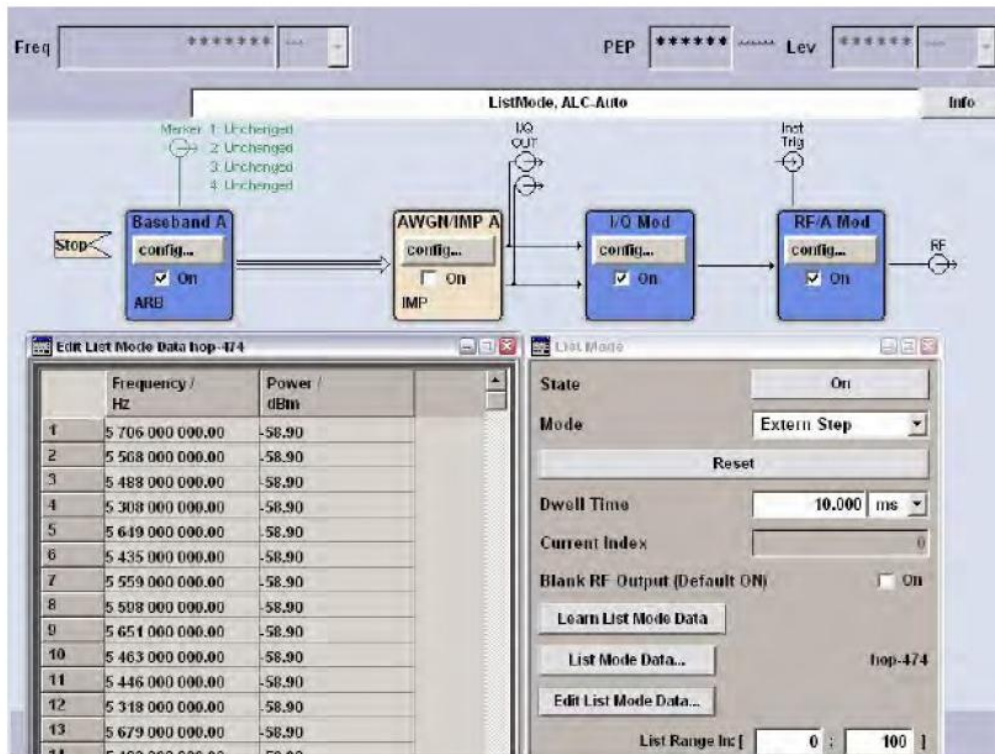

Used R&S SMU200A (Vector SG with two ARB)

B11: Base-band Generator with ARB (16M samples) and Digital Modulation

B13: Base-band Main Module

B106: frequency range (100 kHz to 6 GHz)

For selecting the waveform parameters from within the bounds of the signal type, system was random selection using uniform distribution.

### 5.6. Conducted Calibration Setup

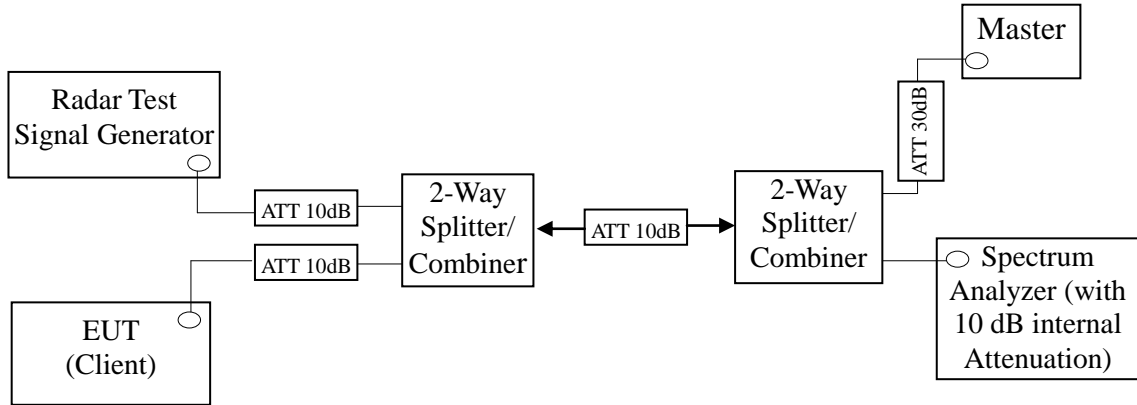

### 5.7. Radar Waveform Calibration Procedure

The measured frequency is 5260MHz & 5290MHz for Band II, 5500MHz & 5530MHz for Band III. The radar signal was the same as transmitted channels, and injected into the antenna port of AP (master) or Client Device with Radar Detection, measured the channel closing transmission time and channel move time. The calibrated conducted detection threshold level is set to -62dBm. The tested level is lower than required level hence it provides margin to the limit.

### 5.8. Calibration Deviation

There is no deviation with the original standard.

### 5.9. Radar Waveform Calibration Result

DFS detection threshold level and the burst of pulses on the Channel frequency

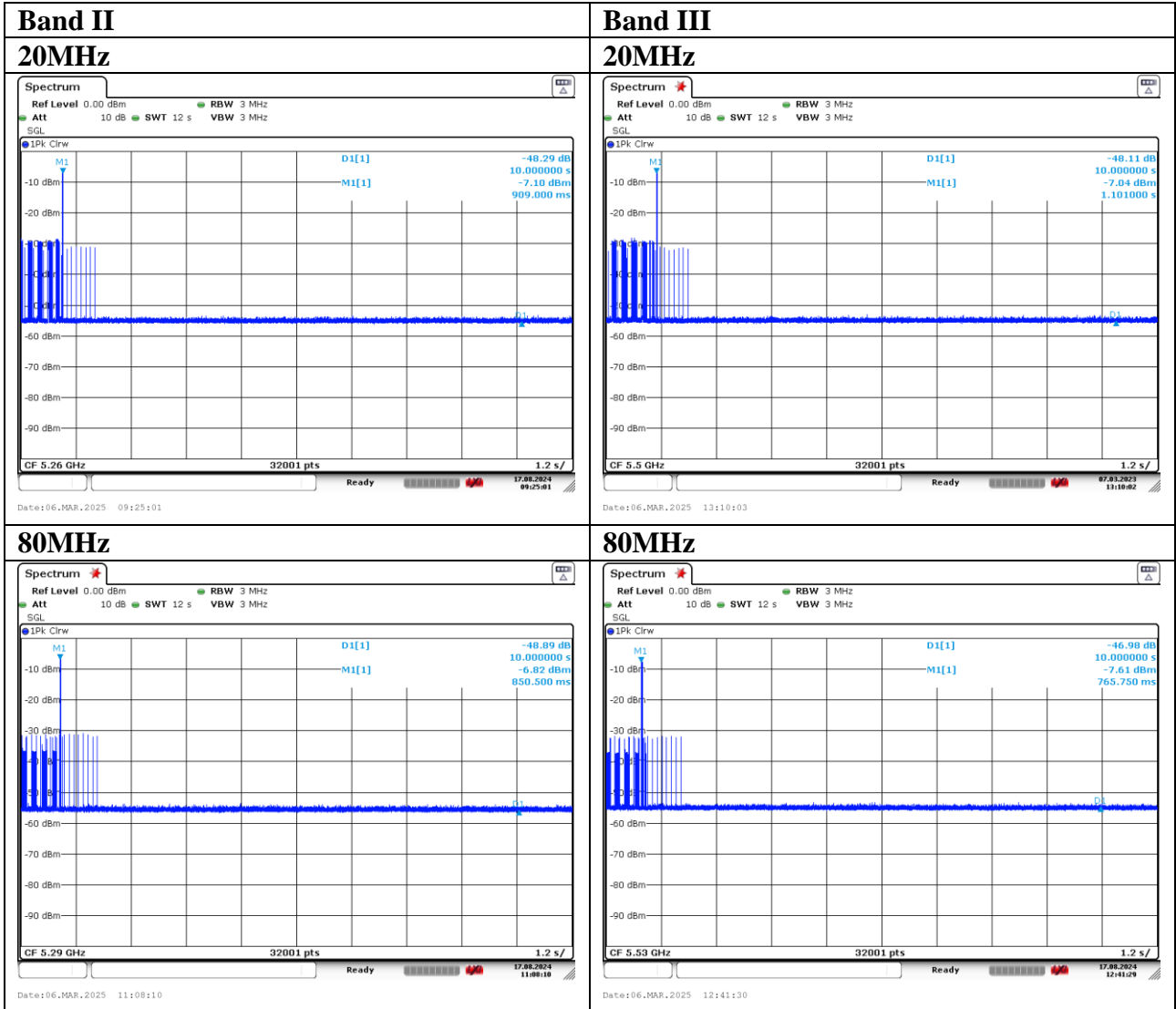

## 6. TEST SETUP AND TEST RESULT

### 6.1. Test Setup

#### 6.1.1. Test Setup Diagram

Following is the test setup for generated the radar waveforms and used to monitor UNII device.

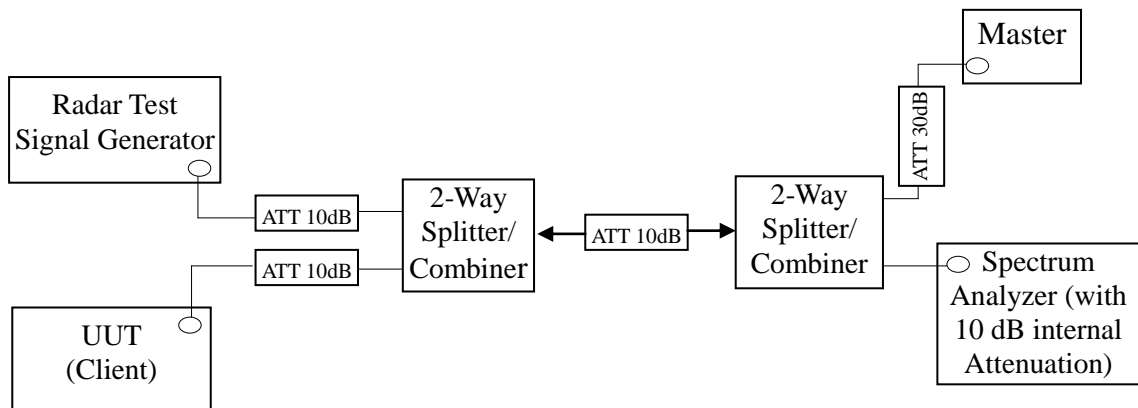

#### 6.1.2. Test Setup Operation

System testing was performed with the designated test file that streams full motion video from the Access Point to Client in full motion video mode using the media player with the V2.61 Codec package. This file is used by IP and Frame based systems for loading the test channel during the in-service compliance testing of the U-NII device.

The waveform parameters from within the bounds of the signal type are selected randomly using uniform distribution.

A spectrum analyzer is used as a monitor to verify that the EUT has vacated the Channel within the (Channel Closing Transmission Time and Channel Move Time, and does not transmit on a Channel during the Non-Occupancy Period after the detection and Channel move. It is also used to monitor EUT transmissions during the Channel Availability Check Time.

6.1.3. Test Setup for Data Traffic Plot

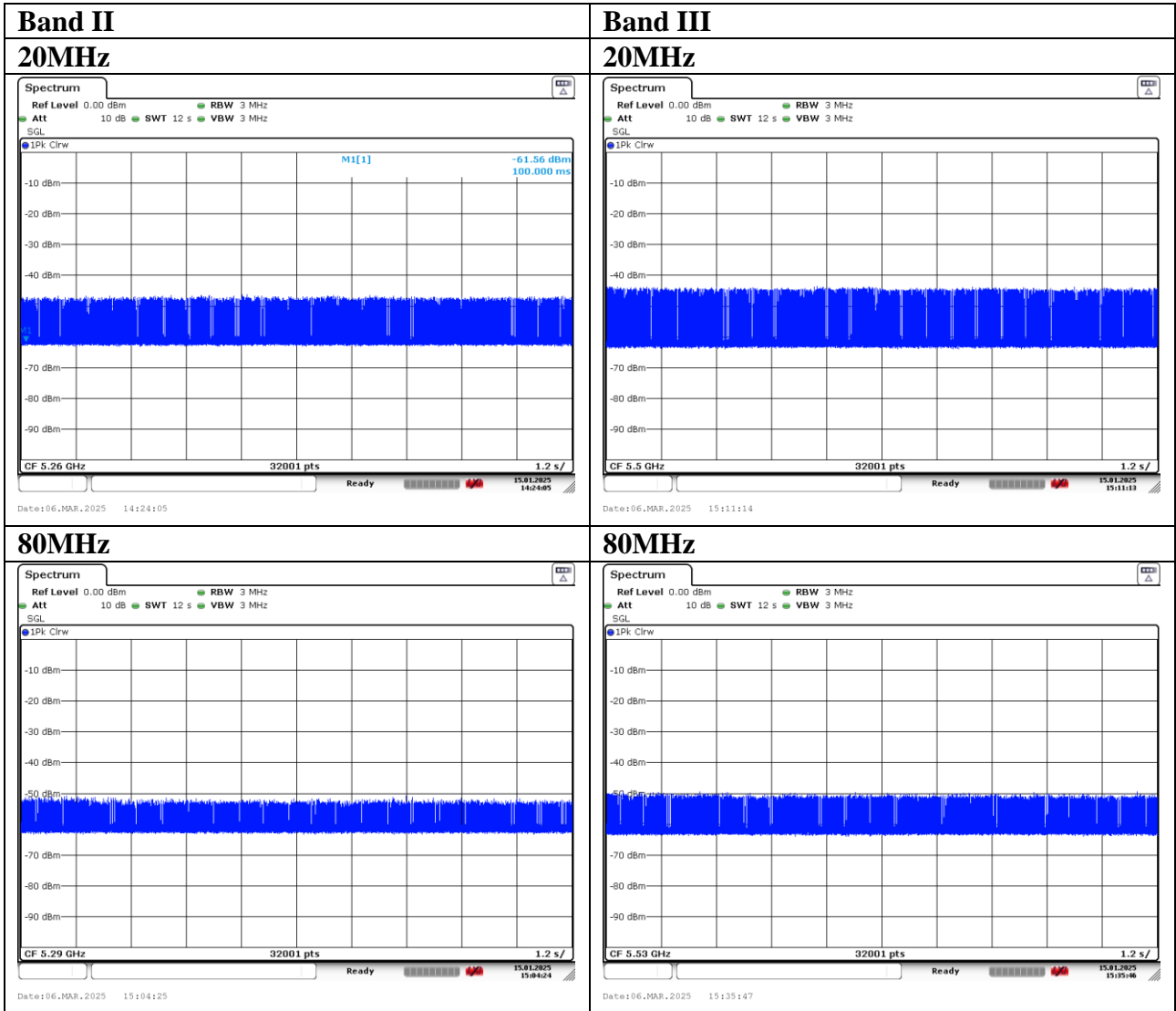

## 6.2. Channel Move Time, Channel Closing Time, Non-Occupancy Period Measurement

### 6.2.1.Limit

Parameter	Value
Channel Move Time	10 seconds See Note 1.
Channel Closing Transmission Time	200 milliseconds + an aggregate of 60 milliseconds over remaining 10 second period. See Notes 1 and 2.

Note 1: The instant that the Channel Move Time and the Channel Closing Transmission Time begins is as follows:

- For the Short Pulse Radar Test Signals this instant is the end of the Burst.
- For the Frequency Hopping radar Test Signal, this instant is the end of the last radar Burst generated.
- For the Long Pulse Radar Test Signal this instant is the end of the 12 second period defining the Radar Waveform.

Note 2: The Channel Closing Transmission Time is comprised of 200 milliseconds starting at the beginning of the Channel Move Time plus any additional intermittent control signals required to facilitate a Channel move (an aggregate of 60 milliseconds) during the remainder of the 10 second period. The aggregate duration of control signals will not count quiet periods in between transmissions.

### 6.2.2. Test Procedures

- 6.2.2.1. When a radar Burst with a level equal to the DFS Detection Threshold + 1dB is generated on the operating channel of the U-NII device. A U-NII device operating as a Client Device will associate with the Master of channel. Stream the MPEG test file from the Master Device to the Client Device on the selected channel for entire period of the test. At time to the radar waveform generator sends a Burst of pulses for each of the radar types at Detection Threshold + 1dB.
- 6.2.2.2. Observe the transmissions of the EUT at the end of the radar Burst on the Operating channel. Measure and record the transmissions from the EUT during the observation time [Channel Move Time]. One 10 Second plot be reported for the short Pulse Radar type 1-4 and one for the Long Pulse Radar Type test in a 22 second plot. The plot for the Short Pulse Radar types start at the end of the radar burst. The Channel Move Time will be calculated based on the plot of the short Pulse Radar Type. The Long Pulse Radar Type plot show the device ceased transmissions within the 10 second window after detection has occurred. The plot for the Long Pulse Radar type should start at the beginning of the 12 second waveform.
- 6.2.2.3. Observe the transmissions of the EUT at the end of the radar Burst on the Operating channel. Measure and record the transmissions from the EUT during the observation time [Channel Move Time]. One 10 Second plot be reported for the short Pulse Radar type 1-4 and one for the Long Pulse Radar Type test in a 22 second plot. The plot for the Short Pulse Radar types start at the end of the radar burst. The Channel Move Time will be calculated based on the plot of the short Pulse Radar Type. The Long Pulse Radar Type plot show the device ceased transmissions within the 10 second window after detection has occurred. The plot for the Long Pulse Radar type should start at the beginning of the 12 second waveform.
- 6.2.2.4. Measure the EUT for more than 30 minutes following the channel close/move time to verify that the EUT does not resume only transmissions on this channel.

6.2.3. Test Result

Applicability of DFS Requirement During Normal Operation

6.2.3.1.Channel Closing Transmission Time & Channel Move Time (PASS)

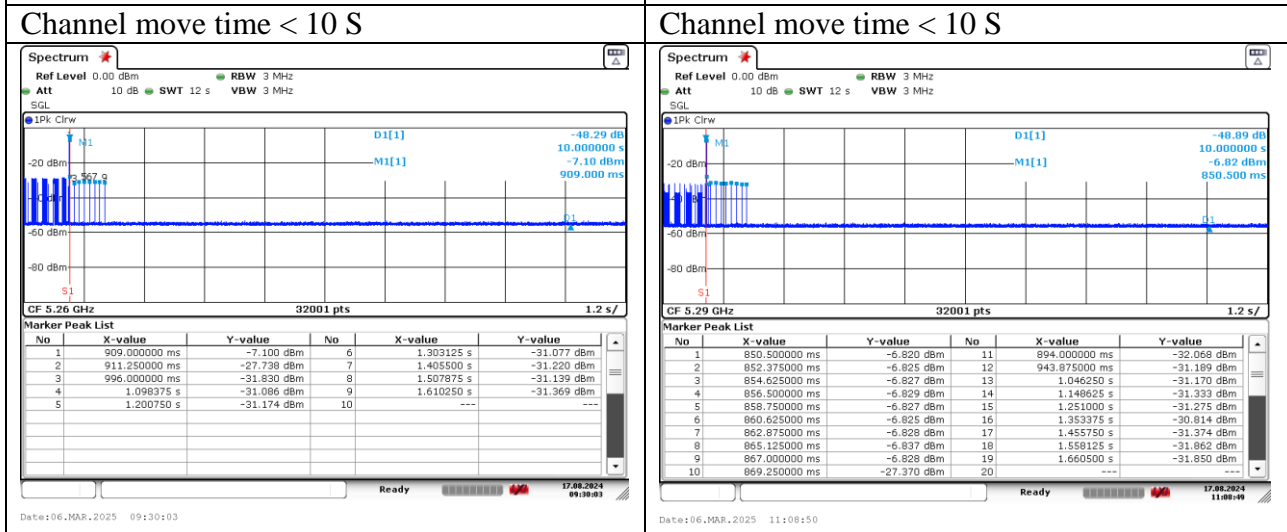
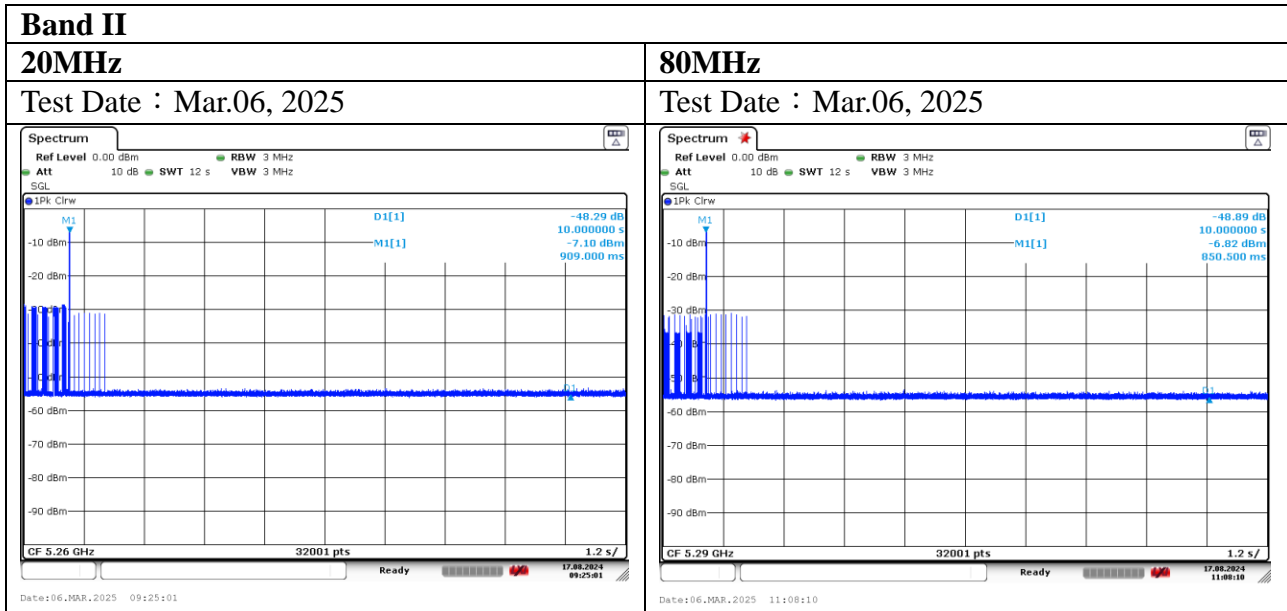

Channel Closing Transmission Time Calculated	
Sweep Time(S) sec	12
Sweep points (P)	32001
Number of Sweep points in 10 sec (N)	9
Channel Closing Time (C)	3.75ms

Channel closing time is calculated from  $C=N \times \text{dwell}$ ; where dwell is the occupancy time per sweep point calculated by the formula:  $\text{dwell}=S/P$ . N is the number of sweep points indicating transmission after S1; where S1 is the radar signal detected.

Channel Closing Transmission Time Calculated	
Sweep Time(S) sec	19
Sweep points (P)	32001
Number of Sweep points in 10 sec (N)	20
Channel Closing Time (C)	7.50ms

Channel closing time is calculated from  $C=N \times \text{dwell}$ ; where dwell is the occupancy time per sweep point calculated by the formula:  $\text{dwell}=S/P$ . N is the number of sweep points indicating transmission after S1; where S1 is the radar signal detected.



**Band III**

**20MHz**

Test Date : Mar.06, 2025

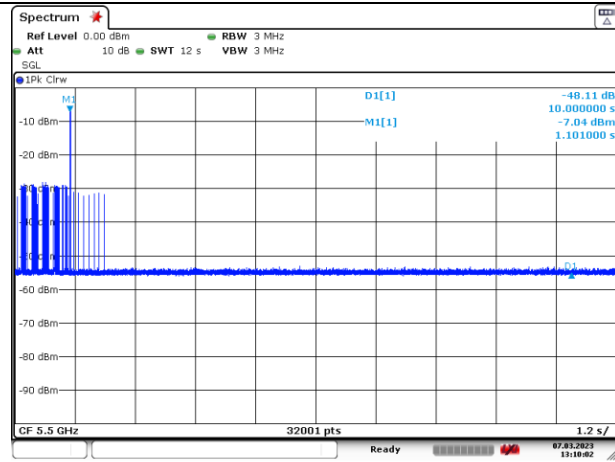

Date:06.MAR.2025 13:10:03

**80MHz**

Test Date : Mar.06, 2025

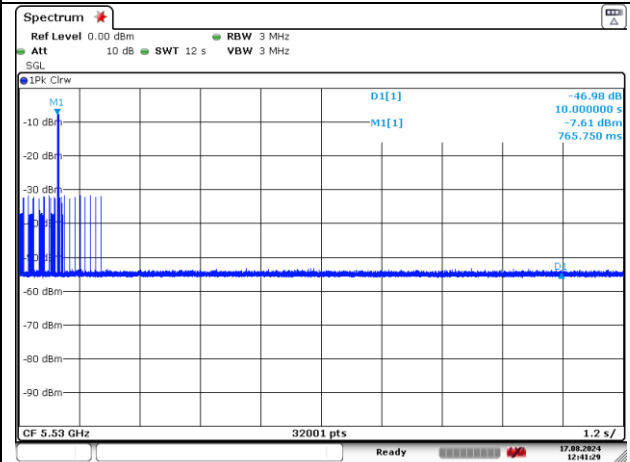

Date:06.MAR.2025 12:41:30

**Channel move time < 10 S**

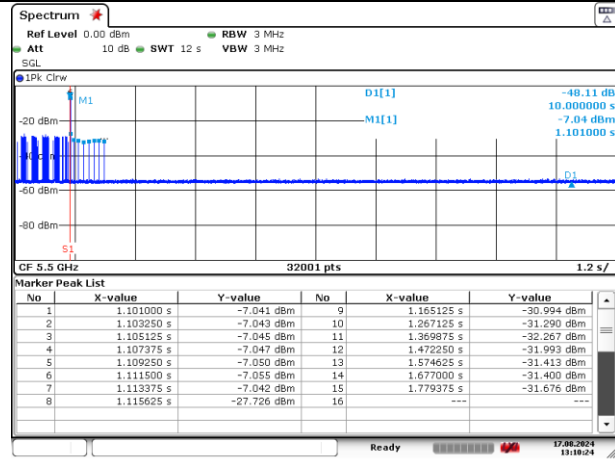

Date:06.MAR.2025 13:10:24

**Channel move time < 10 S**

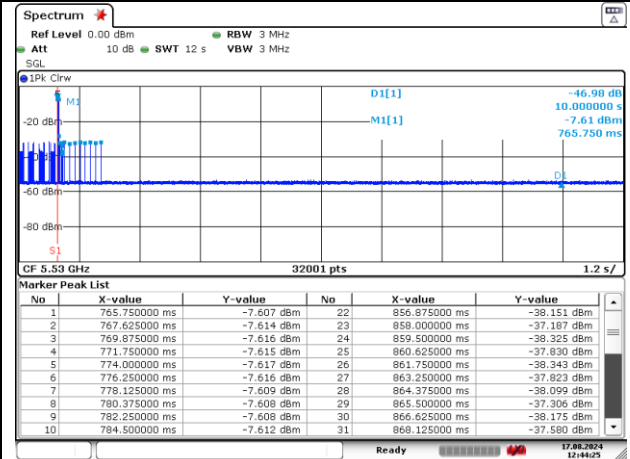

Date:06.MAR.2025 12:44:25

Channel Closing Transmission Time Calculated

Sweep Time(S) sec	12
Sweep points (P)	32001
Number of Sweep points in 10 sec (N)	15
Channel Closing Time (C)	6.00ms

Channel closing time is calculated from  $C=N \times \text{dwell}$ ; where dwell is the occupancy time per sweep point calculated by the formula:  $\text{dwell}=S/P$ . N is the number of sweep points indicating transmission after S1; where S1 is the radar signal detected.

Channel Closing Transmission Time Calculated

Sweep Time(S) sec	12
Sweep points (P)	32001
Number of Sweep points in 10 sec (N)	31
Channel Closing Time (C)	11.62ms

Channel closing time is calculated from  $C=N \times \text{dwell}$ ; where dwell is the occupancy time per sweep point calculated by the formula:  $\text{dwell}=S/P$ . N is the number of sweep points indicating transmission after S1; where S1 is the radar signal detected.

## 8. PHOTOS OF THE EUT

PHOTOS OF THE EUT PLEASE REFER TO APPENDIXB FILE.

..... **THE END** .....