



A Test Lab Techno Corp.

No.140-1, Chang-an St., Bade City, Tao-Yuan County 334, Taiwan (R.O.C.)
Tel : +886-3-2710188 / Fax : +886-3-2710190

Part 15 C Measurement Report



Report No.	:	0905FR13
Applicant	:	Unitech Electronics Co., Ltd.
Trade Mark	:	unitech
Product Model	:	MT180-T7DEAG
Product Type	:	An Economy Versatile T&A Terminal
FCC ID	:	HLEMT18MIFARE01
Dates of Test	:	Apr. 24 ~ May. 06, 2009
Test Specification	:	47 CFR §15.209 47 CFR §15.207 47 CFR §15.107 RSS-210 Issue 7
Location of Test Lab.	:	Chang-An

1. The test operations have to be performed with cautious behavior, the test results are as attached.
2. The test results are under chamber environment of A Test Lab Techno Corp. A Test Lab Techno Corp. does not assume responsibility for any conclusions and generalizations drawn from the test results with regard to other specimens or samples.
3. The measurement report has to be written approval of A Test Lab Techno Corp. It may only be reproduced or published in full. This report shall not be reproduced except in full, without the written approval of A Test Lab Techno Corp.
4. This document may be altered or revised by A Test Lab Techno. Corp. personnel only, and shall be noted in the revision section of the document.

Kevin Wang **20090605**
Approve Signre

John Cheng **20090605**
Testing Engineer



CERTIFICATION

We here by verify that:

The test data, data evaluation, test procedures and equipment configurations shown in this report were made in accordance with the procedures given in ANSI C63.4:2001. All test were conducted by *A Test Lab Techno Corp. No.140-1, Chang-an St., Bade City, Tao-Yuan County 334, Taiwan (R.O.C.)* Also, we attest to the accuracy of each.

We further submit that the energy emitted by the sample EUT tested as described in the report is in compliance with Class B radiated and conducted emission limit of FCC Rules Part 15 Subpart C (15.209&15.207&15.107) & RSS-210 Issue 7(2007).

Manufacturer : Unitech Electronics Co., Ltd.
5F, No136, Lane 235, Pao-Chiao Rd., Hsin-Tien City, Taipei
Hsien, Taiwan 231, Taiwan

EUT : An Economy Versatile T&A Terminal

Applicant : Unitech Electronics Co., Ltd.
5F, No136, Lane 235, Pao-Chiao Rd., Hsin-Tien City, Taipei Hsien,
Taiwan 231, Taiwan

Trade Mark : unitech

Model No : MT180-T7DEAG

FCC ID : HLEMT18MIFARE01

Approved by : 
Kevin Wang 2009/06/05

Prepared by : 
John Cheng 2009/06/05

A Test Lab Techno Corp.

*No.140-1, Chang-an St., Bade City, Tao-Yuan County 334, Taiwan (R.O.C.)
Tel : 03-2710188 / Fax : 03-2710190*



Contents

1.	GENERAL	4
2.	Conducted Emissions Requirements	8
3.	Radiated Emissions Requirements	14
4.	Frequency Stability	27
5.	Occupied Bandwidth Requirements	29
Appendix A - EUT Test SETUP		31



1. GENERAL

1.1 Description of Equipment under Test (EUT)

Applicant :

Unitech Electronics Co., Ltd.
5F, No136, Lane 235, Pao-Chiao Rd., Hsin-Tien City, Taipei Hsien, Taiwan 231, Taiwan

Manufacturer : Unitech Electronics Co., Ltd.
5F, No136, Lane 235, Pao-Chiao Rd., Hsin-Tien City, Taipei
Hsien, Taiwan 231, Taiwan

Trade Mark : unitech

Product Model : MT180-T7DEAG

Product Type : An Economy Versatile T&A Terminal

FCC ID : HLEMT18MIFARE01

EUT Category: : Radio Transmitter

RF Operating Frequency : 13.56 MHZ

Number of Channels : 1

Type of Antenna : Internal Type

Hardware Version : NA

Software Version : NA

EUT is transmitting and receiving, simultaneously. This device operates with it's transmit and receive circuitry on continuously.

During testing the EUT was operated at Tx / Rx mode for each emission measured. This was done in order to ensure that maximum emission levels were attained.



1.2 Introduction

The following measurement report is submitted on behalf of **Unitech Electronics Co., Ltd.** In support of a Class B Digital Device certification in accordance with Part2 Subpart J and Part 15 Subpart A & B&C and RSS 210 Issue7(2007) of the Commission's and Regulations.

1.3 Summary of Tests

47 CFR Part 15 Subpart C & RSS 210 Issue7				
Reference		Test	Results	Section
47 CFR Part 15.225	RSS 210 Issue7			
15.207(a)	RSSGen(7.2.2)	Conducted Emissions Voltage	PASS	2.6
15.225(a)	RSS210(A2.6)	Limit in the band of 13.553 - 13.567 MHz	PASS	3.5
15.225(b)	RSS210(A2.6)	Limit in the band of 13.410 - 13.553 MHz and 13.567 - 13.710 MHz	PASS	3.5
15.225(c)	RSS210(A2.6)	Limit in the band of 13.110 - 13.410 MHz and 13.710 - 14.010 MHz	PASS	3.5
15.225(d)	RSS210(A2.6)	Limit outside the band of 13.110 - 14.010 MHz	PASS	3.5
15.209	RSS210(A8.5)	Radiated Emission Limits	PASS	3.5
15.225(e)	RSS210(A2.6)	Frequency Stability	PASS	4.4

CFR 47 Part 15.225(2006) / RSS 210 Issue7 (2007) / ANSI C63.4: 2003 / RSS-Gen Issue 2: 2007

1.4 Description of Support Equipment

The EUT itself forms a system. No support equipment is required for its normal operation.

1.5 Configuration of System under Test

PC USB Link

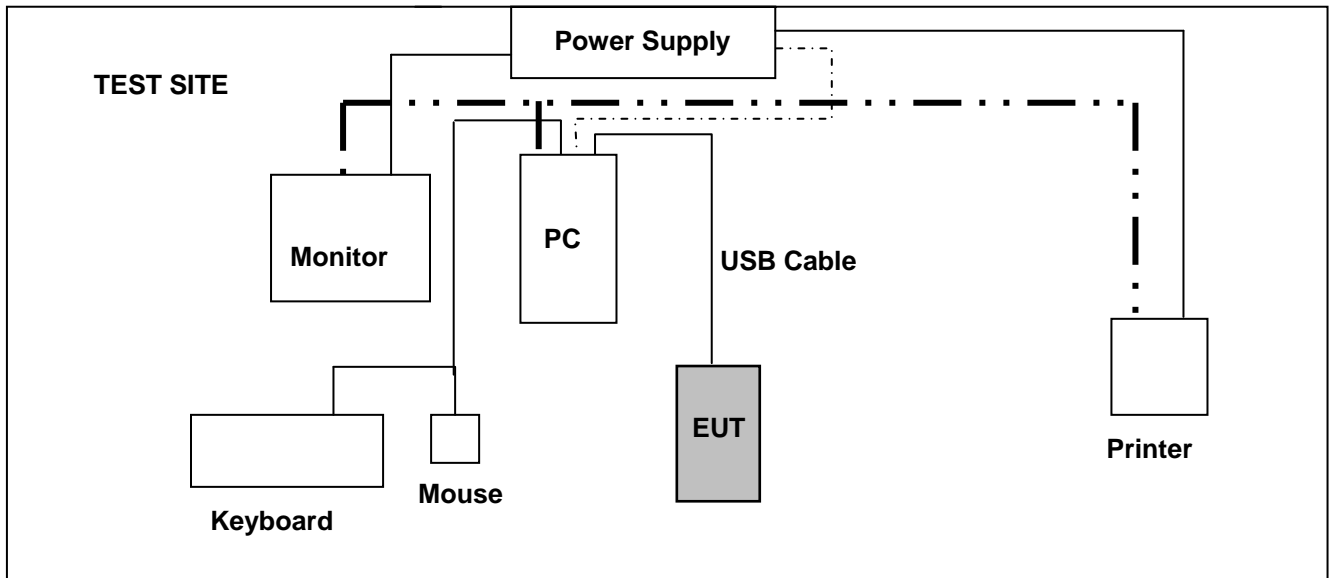

Figure 1. Configuration of System Under Test for PC USB Link

During testing the EUT (An Economy Versatile T&A Terminal)'s USB port connected to the USB port of AE PC. A mouse was connected to the mouse port of IBM PC. And a keyboard was connected to the mouse port of IBM PC. And a printer was connected to the parallel port.



1.6 Test Procedure

All measurements contained in this report were performed according to the techniques described in Measurement procedure ANSI C63.4-2003 "Measurement of un-Intentional Radiators."

1.7 General Test Condition

The conditions under which the EUT operates were varied to determine their effect on the equipment's emission characteristics. The final configuration of the test system and the mode of operation used during these tests were chosen as that which produced the highest emission levels. However, only those conditions which the EUT was considered likely to encounter in normal use were investigated. The systems radiated and conducted emissions were investigated while the computer alternately transferred data to the EUT as well as to the monitor and printer. Using a test program which sent a continuous data and transferred data to and from the EUT was proven to worst case emissions. The system's physical layout and cabling was randomly arranged to ensure that maximum emission levels were attained.



2. Conducted Emissions Requirements

2.1 General & Setup:

The power line conducted emission measurements were performed in a shielded enclosure. The EUT was assembled on a wooden table which is 80 centimeters high, was placed 40 centimeters from the back wall and at least 1 meter from the sidewall.

Power was fed to the EUT from the public utility power grid through a line filter and EMCO Model 3162/2 SH Line Impedance Stabilization Networks (LISN). The LISN housing, measuring instrumentation case, ground plane, etc., were electrically bonded together at the same RF potential. The Spectrum analyzer was connected to the AC line through an isolation transformer. The 50-ohm output of the LISN was connected to the spectrum analyzer directly. Conducted emission levels were in the CISPR quasi-peak detection mode. The analyzer's 6 dB bandwidth was set to 9 KHz. No post-detector video filter was used.

The spectrum was scanned from 150 KHz to 30 MHz. The physical arrangement of the test system and associated cabling was varied (within the scope of arrangements likely to be encountered in actual use) to determine the effect on the unit's emanations in amplitude and frequency. All spurious emission frequencies were observed. The highest emission amplitudes relative to the appropriate limit were measured and have been recorded in paragraph 2.6.

2.2 Test Equipment List:

Describe	Manufacturer	Model	Serial Number	Calibration	
				Cal. Date	Due Date
Spectrum Analyzer	Advantest	R3132	160300103	Mar. 10, 2009	Mar. 10, 2010
Test Receiver	R&S	ESCI	100367	Jun. 05, 2008	Jun. 05, 2009
LISN	EMCO	3816/2 SH	00060110	Jun. 04, 2008	Jun. 04, 2009
LISN	EMCO	3816/2 SH	00060111	Jun. 13, 2008	Jun. 13, 2009
Transient Limiter	ELECTRO-METRICS	EM-7600	777	Jun. 26, 2008	Jun. 26, 2009

2.3 Test Configuration:



Figure 2. Front View of the Test Configuration



Figure 3. Rear View of the Test Configuration



2.4 Test condition:

EUT tested in accordance with the specifications given by the Manufacturer, and exercised in the most unfavorable manner.

Spectrum Analyzer Settings

Measurement Frequency	Preliminary Peak Scan		Final Detection	
	Resolution Bandwidth	Video Bandwidth	Quasi-Peak Bandwidth	Average Video Bandwidth
9kHz to 150kHz	10kHz	10kHz	200Hz	10Hz
150kHz to 30MHz	100kHz	100kHz	9kHz	10Hz

2.5 Conducted Emissions Limits:

Frequency range (MHz)	Limits (dBuV)	
	Quasi-peak	Average
0.15 to 0.50	66 to 56	56 to 46
0.50 to 5.0	56	46
5.0 to 30	60	50



2.6 Measurement Data of Conducted Emissions:

2.6.1 Conducted Emissions (Subpart C)

The following table show a summary of the highest emissions of power line conducted emissions to the HOT and NATURAL conductor of the EUT power.

Applicant : Unitech Electronics Co., Ltd.
Model No : MT180-T7DEAG
EUT : An Economy Versatile T&A Terminal
Test Mode : Link Mode _ 13.56MHz
Test Date : 04/21/2009

Please refer to next pager of detail testing data.

Notes:

1. L1: One end & Ground L2: The other end & Ground
2. Height of table on which the EUT was placed: 0.8 m.
3. The Quasi-Peak Value have already met the Average Value Limit showed on above limits.
4. The above test results are obtained under the normal condition.
5. The test results are the worse case.



Conducted Emission Measurement

Data :#1

Date: 2009-4-21

Time: 下午 01:44:06

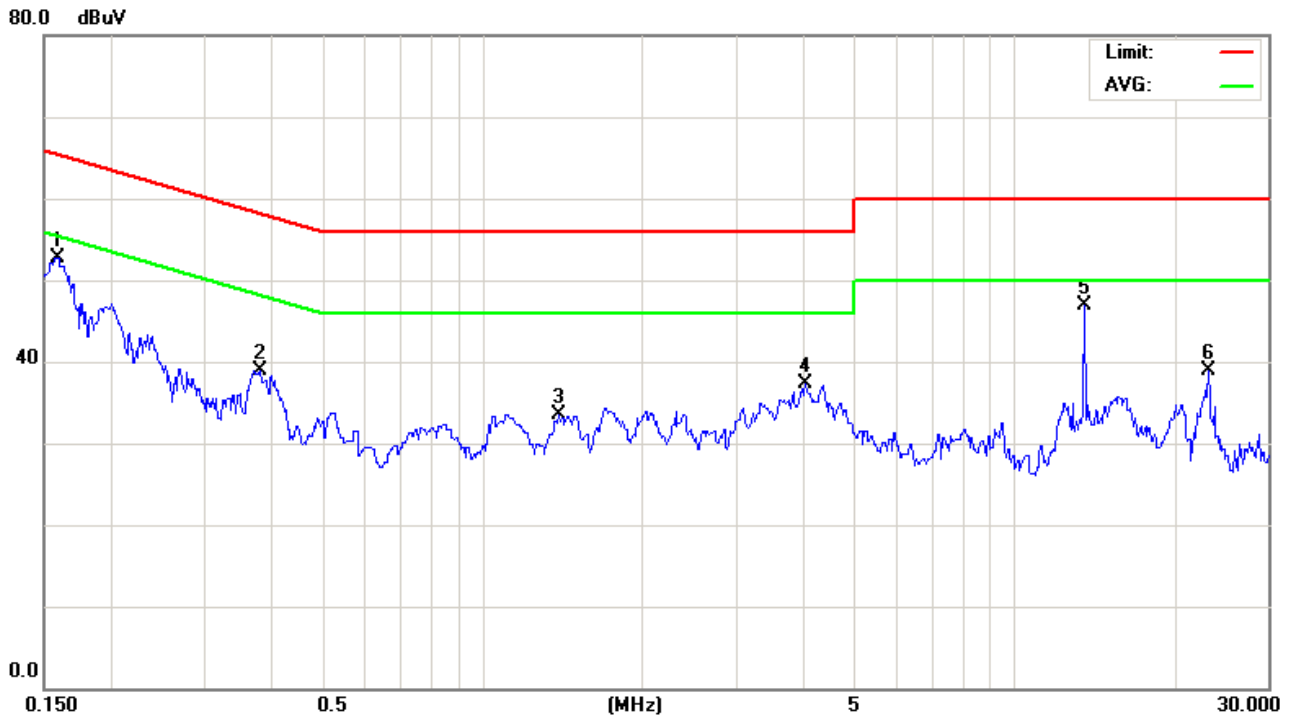

Site site#1

Phase: **L1**

Temperature: 26 °C

Limit: CISPR22 Class B Conduction(QP)

Power: AC 110V/60Hz

Humidity: 55 %

EUT:

M/N: 09-D0302-E

Mode: Mifare(A2)

Note: 13.56MHz

No.	Mk.	Freq. MHz	Reading Level dBuV	Correct Factor dB	Measure- ment dBuV	Limit dBuV	Over dB	Detector	Comment
1	*	0.1590	43.02	9.73	52.75	65.51	-12.76	peak	
2		0.3800	29.15	9.78	38.93	58.28	-19.35	peak	
3		1.3910	23.66	9.82	33.48	56.00	-22.52	peak	
4		4.0370	27.31	9.96	37.27	56.00	-18.73	peak	
5		13.5500	36.72	10.21	46.93	60.00	-13.07	peak	
6		23.1000	28.58	10.38	38.96	60.00	-21.04	peak	

*:Maximum data x:Over limit !:over margin

●Reference Only



Conducted Emission Measurement

Data :#2

Date: 2009-4-21

Time: 下午 01:49:13

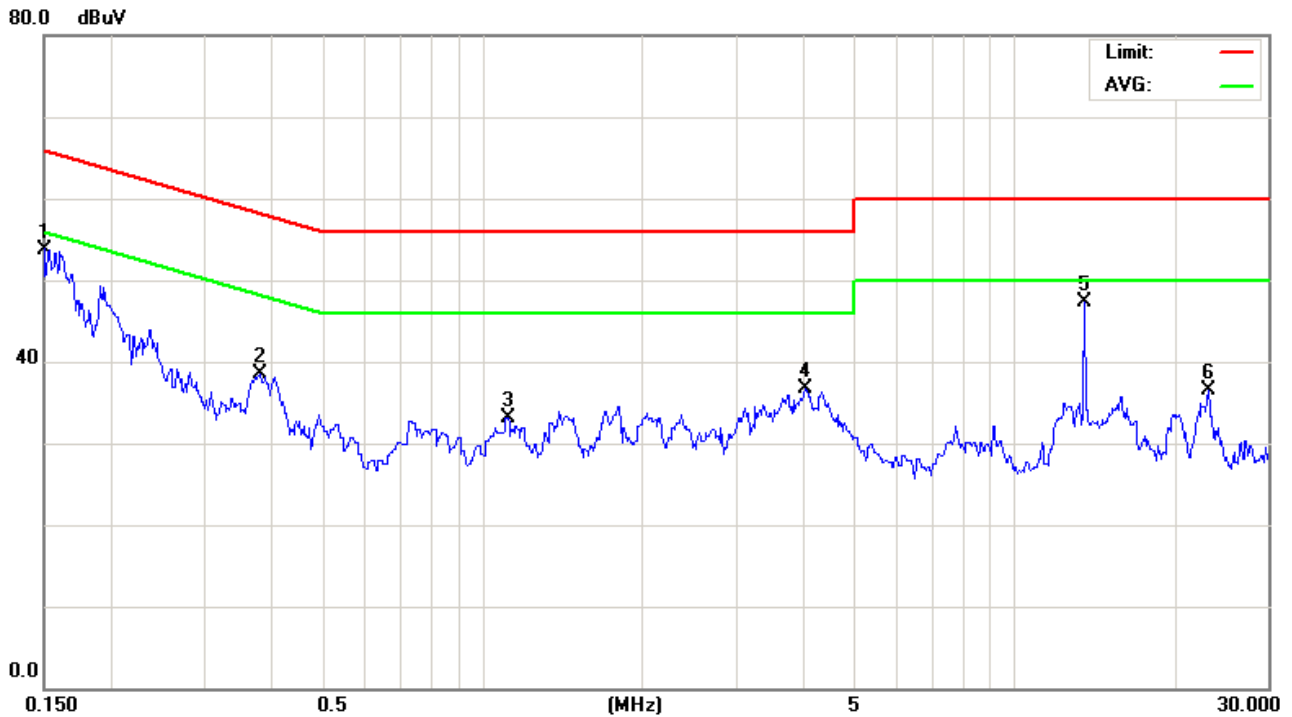

Site site#1

Phase: **L2**

Temperature: 26 °C

Limit: CISPR22 Class B Conduction(QP)

Power: AC 110V/60Hz

Humidity: 55 %

EUT:

M/N: 09-D0302-E

Mode: Mifare(A2)

Note: 13.56MHz

No.	Mk.	Freq. MHz	Reading Level dBuV	Correct Factor dB	Measure- ment dBuV	Limit dBuV	Over dB	Detector	Comment
1	*	0.1500	44.07	9.73	53.80	65.99	-12.19	peak	
2		0.3817	28.78	9.78	38.56	58.24	-19.68	peak	
3		1.1119	23.33	9.80	33.13	56.00	-22.87	peak	
4		4.0460	26.70	9.96	36.66	56.00	-19.34	peak	
5		13.5500	37.06	10.21	47.27	60.00	-12.73	peak	
6		23.1000	26.19	10.38	36.57	60.00	-23.43	peak	

*:Maximum data x:Over limit !:over margin

●Reference Only



3. Radiated Emissions Requirements

3.1 Final radiation measurements were made on a three-meter:

Final radiation measurements were made on a three-meter, Semi Anechoic Chamber. The EUT system was placed on a nonconductive turntable which is 0.8 meters height, top surface 1.0 x 1.5 meter. The spectrum was examined from 250 MHz to 2.5 GHz in order to cover the whole spectrum below 10th harmonic which could generate from the EUT. During the test, EUT was set to transmit continuously & Measurements spectrum range from 30 MHz to 26.5 GHz is investigated.

For measurements below 1 GHz the resolution bandwidth is set to 100 kHz for peak detection measurements or 120 kHz for quasi-peak detection measurements. Peak detection is used unless otherwise noted as quasi-peak. For measurements above 1 GHz the resolution bandwidth is set to 1 MHz, and then the video bandwidth is set to 1 MHz for peak measurements and 10 Hz for average measurements.

A nonconductive material surrounded the EUT to supporting the EUT for standing on three orthogonal planes. At each condition, the EUT was rotated 360 degrees, and the antenna was raised and lowered from one to four meters to find the maximum emission levels. Measurements were taken using both horizontal and vertical antenna polarization.

ETS-Lindgren Loop Antenna (Model 6502) was used in frequencies 9kHz - 30MHz at a distance of 3 Meter and SCHWARZBECK MESS-ELEKTRONIK Biconilog Antenna (model VULB9163) was used in frequencies 30MHz - 1GHz at a distance of 3 Meter and the SCHWARZBECK Double Ridged Guide Antenna (model BBHA9120D&9170) was used in frequencies 1 - 26.5 GHz at a distance of 1 meter. All test results were extrapolated to equivalent signal at 3 meters utilizing an inverse linear distance extrapolation Factor (20dB/decade).

For testing above 1GHz, the emission level of the EUT in peak mode was 20dB lower than average limit (that means the emission level in peak mode also complies with the limit in average mode), then testing will be stopped and peak values of EUT will be reported, otherwise, the emissions will be measured in average mode again and reported.

Appropriate preamplifiers were used for improving sensitivity and precautions were taken to avoid overloading or desensitizing the spectrum analyzer. No post - detector video filters were used in the test.



The spectrum analyzer's 6 dB bandwidth was set to 1 MHz, and the analyzer was operated in the peak detection mode, for frequencies both below and up 1 GHz. The average levels were obtained by subtracting the duty cycle correction factor from the peak readings.

The following procedures were used to convert the emission levels measured in decibels referenced to 1 microvolt (dBuV) into field intensity in micro volts per meter (uV/m).

The actual field intensity in decibels referenced to 1 microvolt in to field intensity in micro volts per meter (dBuV/m).

The actual field intensity in decibels referenced to 1 microvolt per meter (dBuV/m) is determined by algebraically adding the measured reading in dBuV, the antenna factor (dB), and cable loss (dB) and Subtracting the gain of preamplifier (dB) is auto calculate in spectrum analyzer.

$$(1) \text{ Amplitude (dBuV/m)} = \text{FI (dBuV)} + \text{AF (dBuV)} + \text{CL (dBuV)} - \text{Gain (dB)}$$

FI= Reading of the field intensity.

AF= Antenna factor.

CL= Cable loss.

P.S Amplitude is auto calculate in spectrum analyzer.

$$(2) \text{ Actual Amplitude (dBuV/m)} = \text{Amplitude (dBuV)} - \text{Dis(dB)}$$

The FCC specified emission limits were calculated according the EUT operating frequency and by following linear interpolation equations:

(a) For fundamental frequency :

Transmitter Output < +30dBm

(b) For spurious frequency :

Spurious emission limits = fundamental emission limit /10



3.2 Test Equipment List:

Describe	Manufacturer	Model	Serial Number	Calibration	
				Cal. Date	Due Date
Spectrum Analyzer	Agilent	E4408B	MY45107753	Jun. 05, 2008	Jun. 05, 2009
Pre Amplifier	Agilent	8449B	3008A02237	Jun. 03, 2008	Jun. 03, 2009
Pre Amplifier	Agilent	8447D	2944A10961	Jun. 10, 2008	Jun. 10, 2009
Test Receiver	R&S	ESCI	100367	Jun. 05, 2008	Jun. 05, 2009
Biconilog Antenna	SCHWARZBECK MESS-ELEKTRONIK	VULB9163	9163-270	Jun. 26, 2008	Jun. 26, 2009
Horn Antenna	SCHWARZBECK MESS-ELEKTRONIK	BBHA9120D	9120D-550	Jun. 26, 2008	Jun. 26, 2009
Horn Antenna	SCHWARZBECK MESS-ELEKTRONIK	BBHA9170	9170-320	Jun. 09, 2008	Jun. 09, 2009
Horn Antenna	SCHWARZBECK MESS-ELEKTRONIK	BBHA9120E	0899	Jun. 26, 2008	Jun. 26, 2009
Loop Antenna	ETS-Lindgren	6502	00042960	Jan. 14, 2009	Jan. 14, 2010

3.3 Test Configuration:

Loop antenna positioned at 0 degrees



Figure 4. Front View of the Test Configuration



Figure 5. Rear View of the Test Configuration

Loop antenna positioned at 90 degrees



Figure 6. Front View of the Test Configuration

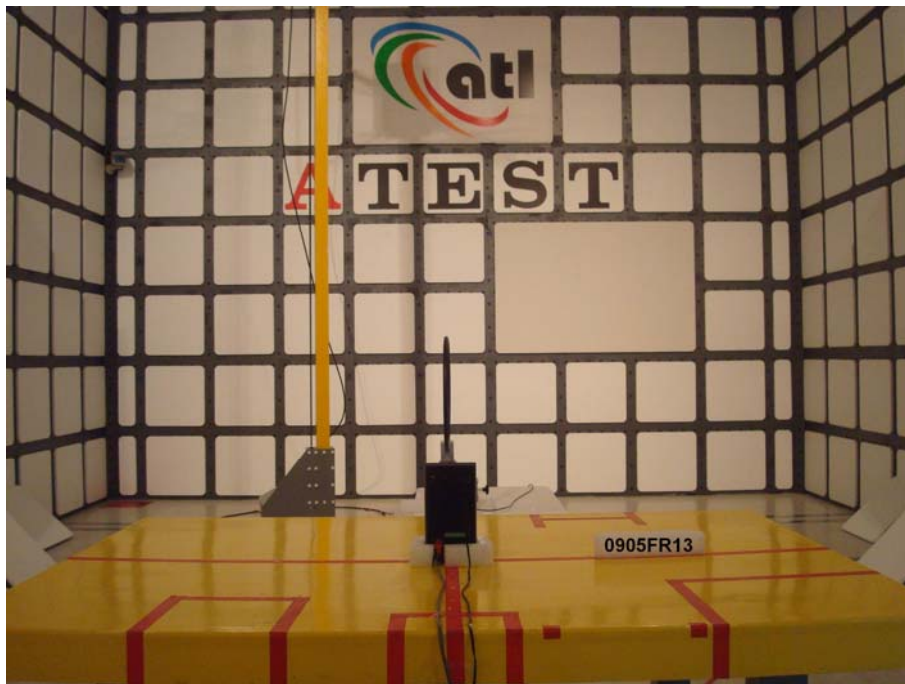

Figure 7. Rear View of the Test Configuration

Below 1GHz



Figure 8. Front View of the Test Configuration



Figure 9. Rear View of the Test Configuration



3.4 Test condition:

EUT tested in accordance with the specifications given by the manufacturer, and exercised in the most unfavorable manner.

Spectrum Analyzer Settings

Measurement Frequency	Preliminary Peak Scan		Final Detection	
	Resolution Bandwidth	Video Bandwidth	Quasi-Peak Bandwidth	Average Video Bandwidth
9kHz to 150kHz	10kHz	1MHz	200Hz	10Hz
150kHz to 30MHz	100kHz	1MHz	9kHz	10Hz
30 to 1000 MHz	120KHz	120KHz	120KHz	10Hz

3.5 Radiated Emissions Limits:

Frequency range (MHz)	Limit (dBuV/m)
0.009 to 0.490	128.5 - 93.8
0.490 to 1.705	73.8 - 62.97
1.705 to 30	69.5
30 to 88	40
88 to 216	43.5
216 to 960	46
Above 960	54



3.6 Measurement Data of Radiated Emissions:

3.6.1 Open Field Radiated Emissions (Subpart C) _ 13.110 - 14.010 MHz

The highest peak values of radiated emissions from the EUT at various antenna heights, antenna polarization, EUT orientation, etc. are recorded on the following.

Applicant : Unitech Electronics Co., Ltd.
 Model No : MT180-T7DEAG
 EUT : An Economy Versatile T&A Terminal
 Test Mode : Link Mode_ 13.56MHz
 Test Date : 05/06/2009

Radiated Emissions _ Loop antenna positioned at 0 degrees								
Freq. (MHz)	Read level	Cable loss	Factor		Amplitude (dBuV/m)	Limits(Class B) (dBuV/m)	Margin (dB)	Detector
			Antenna	Distance correction				
13.56	61.25	0.5	19.78	40	41.53	84	-42.47	peak

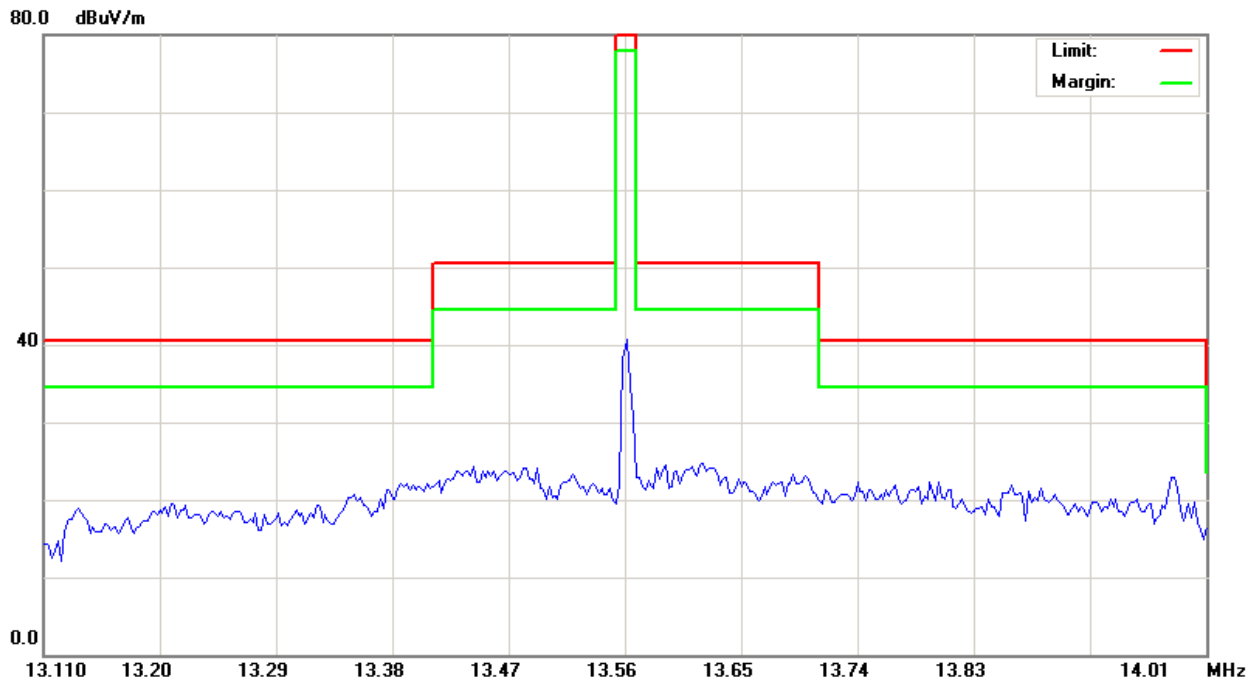



Radiated Emissions _ Loop antenna positioned at 90 degrees								
Freq. (MHz)	Read level	Cable loss	Factor		Amplitude (dBuV/m)	Limits(Class B) (dBuV/m)	Margin (dB)	Detector
			Antenna	Distance correction				
13.56	59.18	0.5	19.78	40	39.46	84	-44.54	peak

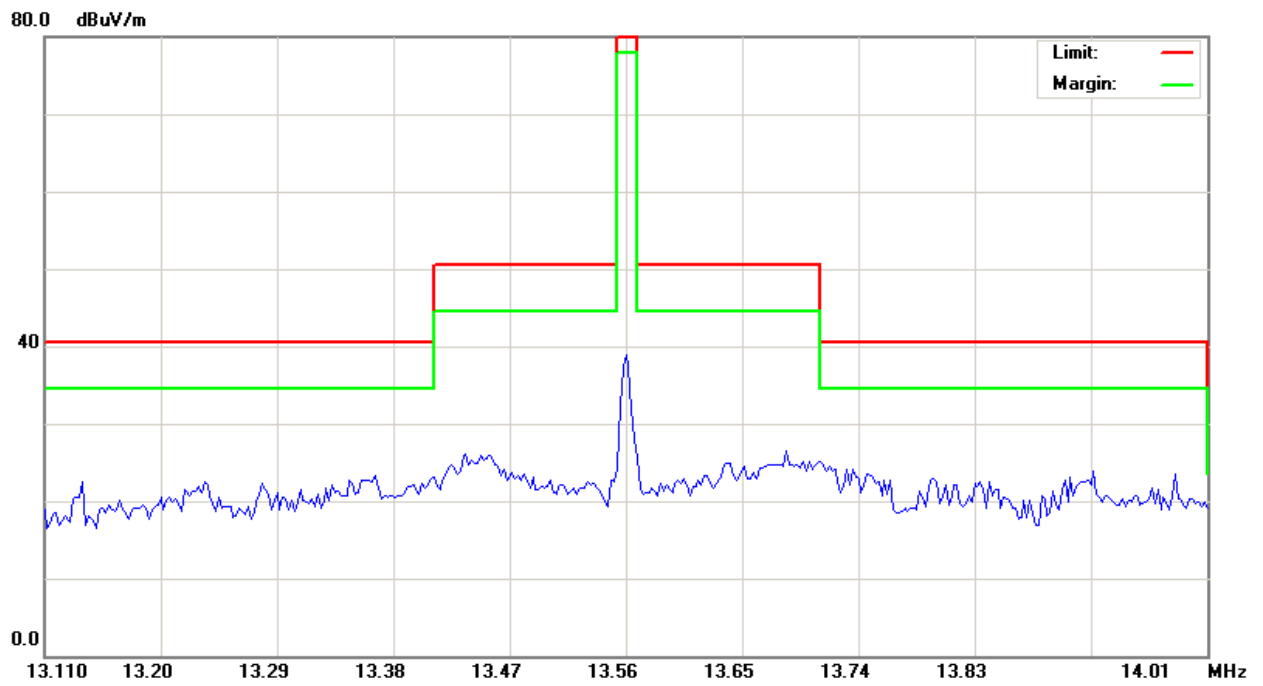



3.6.2 Open Field Radiated Emissions (Subpart C) < 30 MHz (outside 13.110 – 14.010 MHz)

The highest peak values of radiated emissions from the EUT at various antenna heights, antenna polarization, EUT orientation, etc. are recorded on the following.

Applicant : Unitech Electronics Co., Ltd.
 Model No : MT180-T7DEAG
 EUT : An Economy Versatile T&A Terminal
 Test Mode : Link Mode_ 13.56MHz
 Test Date : 05/06/2009

Radiated Emissions _ Loop antenna positioned at 0 degrees								
Freq. (MHz)	Read level	Cable loss	Factor		Amplitude (dBuV/m)	Limits(Class B) (dBuV/m)	Margin (dB)	Detector
			Antenna	Distance correction				
1.5436	32.66	0.5	20.14	40	13.3	29.54	-16.24	peak
23.9825	33.51	0.5	20.39	40	14.4	29.54	-15.14	peak

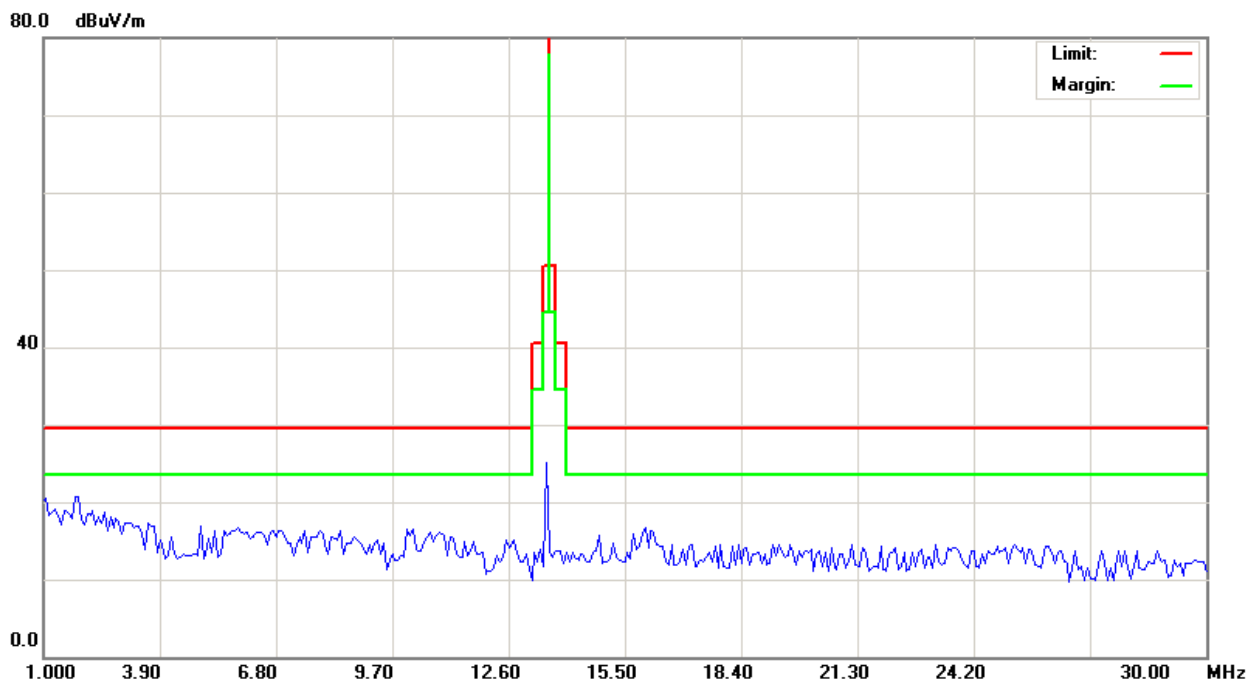



Radiated Emissions _ Loop antenna positioned at 90 degrees

Freq. (MHz)	Read level	Cable loss	Factor		Amplitude (dBuV/m)	Limits(Class B) (dBuV/m)	Margin (dB)	Detector
			Antenna	Distance correction				
1.965	31.76	0.5	20.14	40	12.4	29.54	-17.14	peak
22.8543	32.57	0.5	20.39	40	13.46	29.54	-16.08	peak

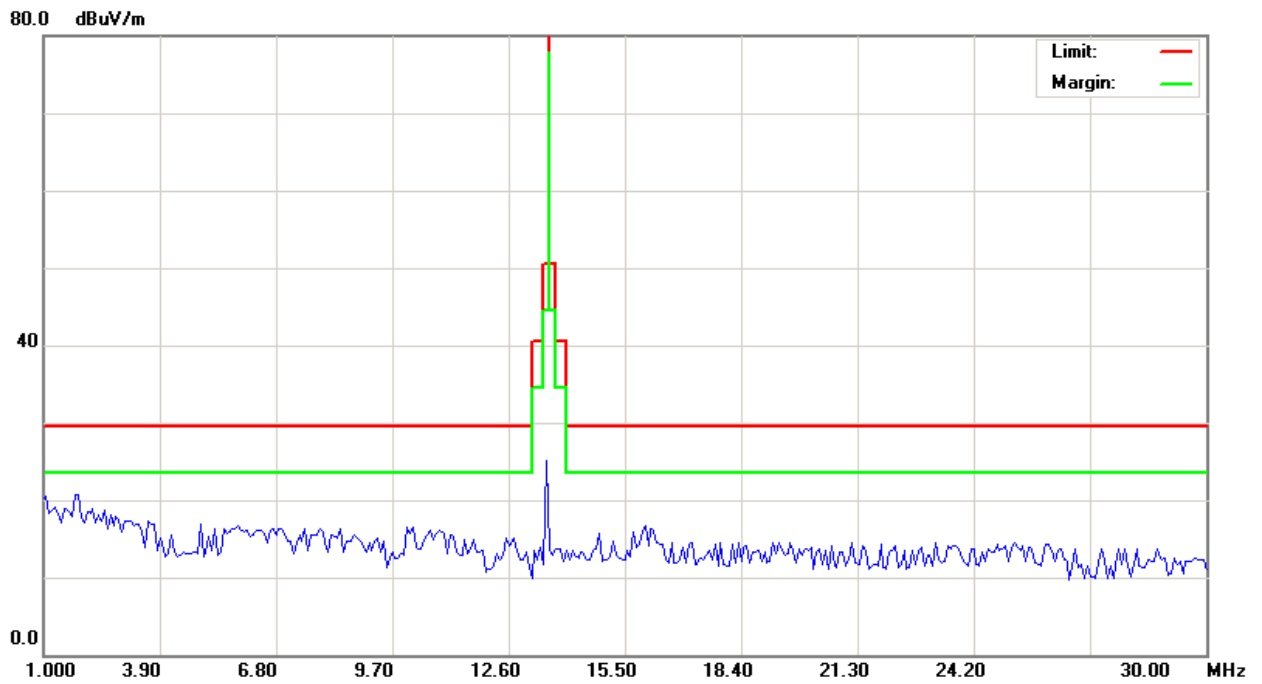



3.6.3 Open Field Radiated Emissions (Subpart C) _ > 30 MHz

The highest peak values of radiated emissions from the EUT at various antenna heights, antenna polarization, EUT orientation, etc. are recorded on the following.

Applicant : Unitech Electronics Co., Ltd.
Model No : MT180-T7DEAG
EUT : An Economy Versatile T&A Terminal
Test Mode : Link Mode _ 13.56MHz
Test Date : 05/08/2009

Radiated Emissions _ H Polarization						
Frequency (MHz)	Read level	Factor	Amplitude (dBuV/m)	Limits(Class B) (dBuV/m)	Margin (dB)	Detector
31.35	33.46	-13.29	20.17	40.0	-19.83	peak
55.92	35.15	-12.27	22.88	40.0	-17.12	peak
82.11	38.73	-15.78	22.95	40.0	-17.05	peak
103.71	32.51	-12.00	20.51	43.5	-22.99	peak
189.84	41.82	-13.38	28.44	43.5	-15.06	peak
240.06	42.60	-11.43	31.17	46.0	-14.83	peak
359.50	40.17	-8.98	31.19	46.0	-14.81	peak
479.90	46.73	-7.53	39.20	46.0	-6.80	peak
599.60	34.33	-4.91	29.42	46.0	-16.58	peak
720.00	33.36	-3.55	29.81	46.0	-16.19	peak
780.20	37.96	-2.36	35.60	46.0	-10.4	peak
900.60	29.45	-0.36	29.09	46.0	-16.91	peak



Radiated Emissions _ V Polarization						
Frequency (MHz)	Read level	Factor	Amplitude (dBuV/m)	Limits(Class B) (dBuV/m)	Margin (dB)	Detector
47.82	46.51	-12.02	34.49	40.0	-5.51	peak
64.56	50.93	-14.19	36.74	40.0	-3.26	peak
84.54	50.15	-14.89	35.26	40.0	-4.74	peak
101.82	43.45	-11.88	31.57	43.5	-11.93	peak
189.84	48.51	-13.38	35.13	43.5	-8.37	peak
240.06	44.32	-11.43	32.89	46.0	-13.11	peak
359.50	41.44	-8.98	32.46	46.0	-13.54	peak
479.90	49.72	-7.53	42.19	46.0	-3.81	peak
599.60	34.25	-4.91	29.34	46.0	-16.66	peak
677.30	33.02	-4.18	28.84	46.0	-17.16	peak
780.20	32.70	-2.36	30.34	46.0	-15.66	peak
900.60	28.95	-0.36	28.59	46.0	-17.41	peak

Notes:

1. Margin= Amplitude - Limits
2. Distance of Measurement: 3 Meter (30-1000MHz) & (1-10GHz), 1 Meter (10-26.5GHz)
3. Height of table for EUT placed: 0.8 Meter.
4. ANT= Antenna height.
5. Amplitude= Reading Amplitude - Amplifier gain + Cable loss + Antenna factor
(Auto calculate in spectrum analyzer)
6. The EUT was worst case on X axis after pretest on X & Y & Z axis setting.
7. The testing data only show below 18GHz's data because measure data above 18GHz was only ambient noise.
8. All frequencies from 30MHz to 26.5GHz have been tested

4. Frequency Stability

4.1 Test Condition & Setup:

1. The EUT and test equipment were set up as shown on the following section.
2. With all power removed, the temperature was decreased to -30°C and permitted to stabilize for three hours. Power was applied and the maximum change in frequency was note within one minute.
3. With power OFF, the temperature was raised in 10°C steps. The sample was permitted to stabilize at each step for at least one-half hour. Power was applied and the maximum frequency change was noted within one minute.
4. The temperature tests were performed for the worst case.
5. Test data was recorded.

4.2 Test Instruments Configuration:

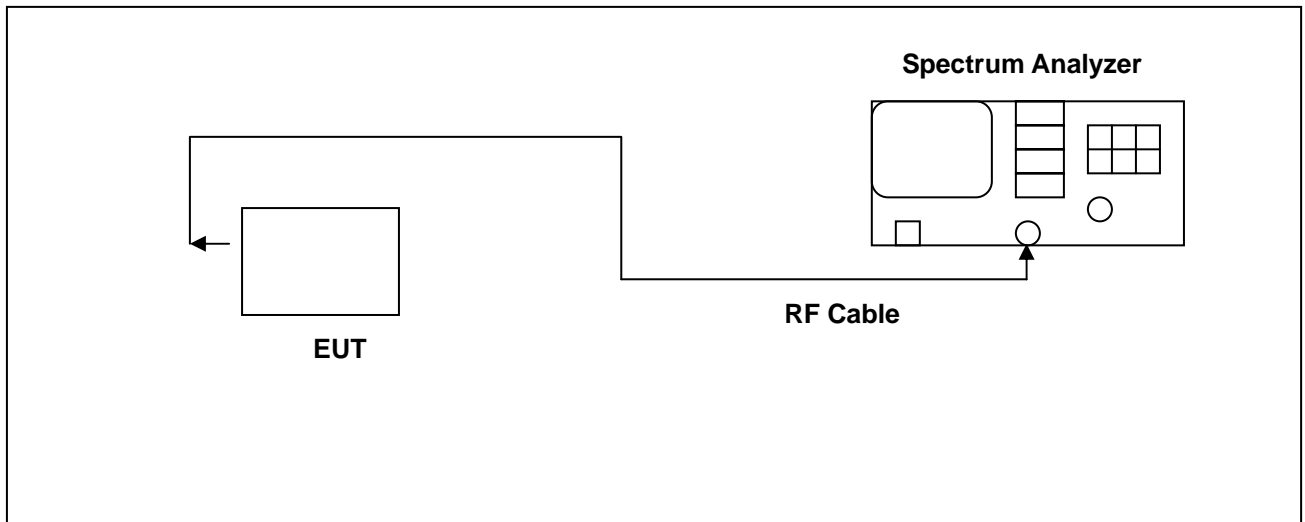



4.3 Test Equipment List:

Describe	Manufacturer	Model	Serial Number	Calibration	
				Cal. Date	Due Date
Spectrum Analyzer	Agilent	E4445A	MY45300744	Nov. 29, 2008	Nov. 29, 2009

4.4 Test Result

Frequency versus Temperature

Temperature (°C)	Measured Freq. (MHz)	Freq. Drift (Hz)	Freq. Drift (%)	Limit (%)
50	13.560556	119	0.00088	0.01
40	13.560768	331	0.00244	0.01
30	13.560713	276	0.00204	0.01
20	Reference			
10	13.560447	10	0.00007	0.01
0	13.560532	95	0.00070	0.01
-10	13.560556	119	0.00088	0.01
-20	13.560327	-110	-0.00081	0.01
-30	13.560617	180	0.00133	0.01
Reference Frequency: Measured 13.560816 MHz at 20°C				

Frequency versus Voltage

Measured Voltage 15% of nominal (AC)	Measured Freq. (MHz)	Freq. Drift (Hz)	Freq. Drift (%)	Limit (%)
138	13.560815	223	0.00164	0.01
102	13.560663	71	0.00052	0.01
Reference Frequency: Measured 13.560843 MHz at 20°C with 120 Vac / 60 Hz				

5. Occupied Bandwidth Requirements

5.1 Test Condition & Setup:

The RF output port of the Equipment-Under-Test is directly coupled to the input of the EMC analyzer through a specialized RF connector and a 10dB passive attenuator. A fully charged battery was used for the supply voltage. The Bluetooth frequency hopping function of the EUT was enabled. The spectrum analyzer used the following settings:

1. Span = 30 kHz
2. RBW \geq 1% of the 20dB span
3. VBW \geq RBW
4. Sweep = auto
5. Detector function = peak
6. Trace = max hold

The trace was allowed to stabilize. The EUT was transmitting at its maximum data rate. The marker-to-peak function was used to set the marker to the peak of the emission. The marker-delta function was used to measure 20dB down one side of the emission. The marker-delta function and marker was moved to the other side of the emission until it was even with the reference marker. The marker-delta reading at this point was the 20dB bandwidth of the emission.

5.2 Test Instruments Configuration:

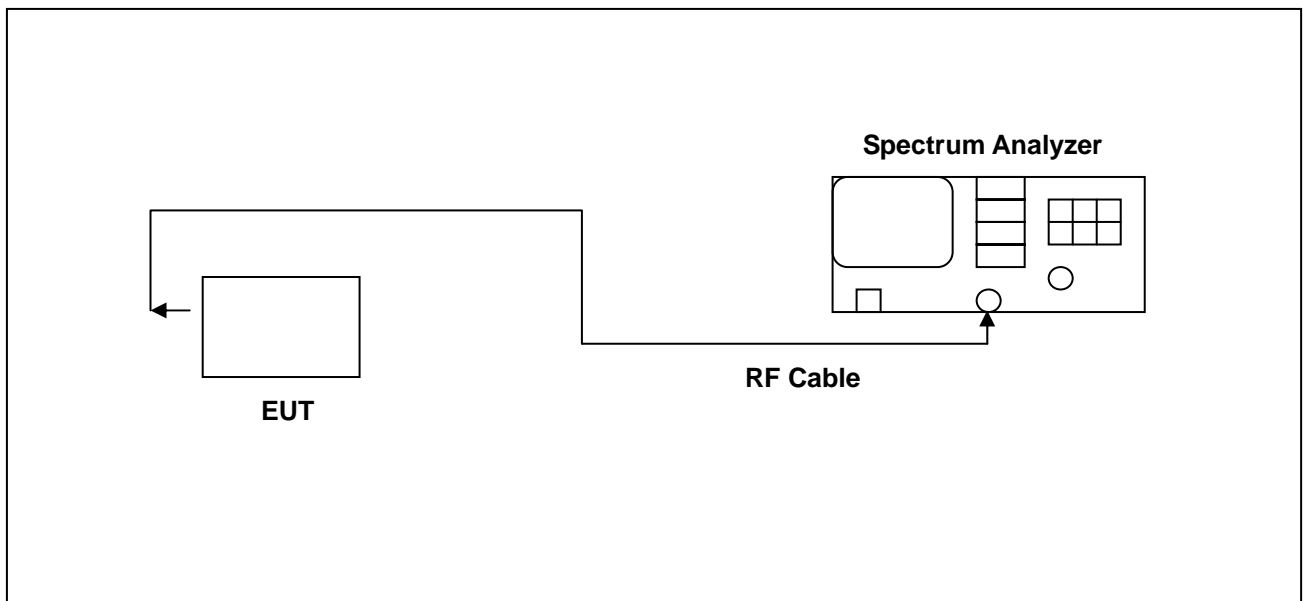



5.3 Test Equipment List:

Describe	Manufacturer	Model	Serial Number	Calibration	
				Cal. Date	Due Date
Spectrum Analyzer	Agilent	E4445A	MY45300744	Dec. 22, 2008	Dec. 22, 2009

5.4 Test Result

Frequency (MHz)	99 % Bandwidth (KHz)
13.560918	2.5548

5.5 Test Graphs

99% Bandwidth

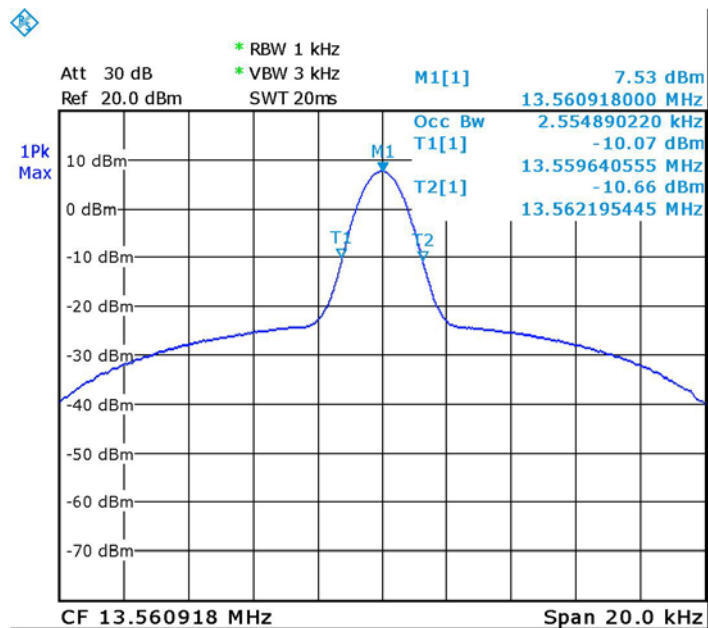

Date: 3.MAY.2009 14:18:21

Appendix A - EUT Test SETUP

MEASUREMENT OF POWER LINE CONDUCTED RFI VOLTAGE

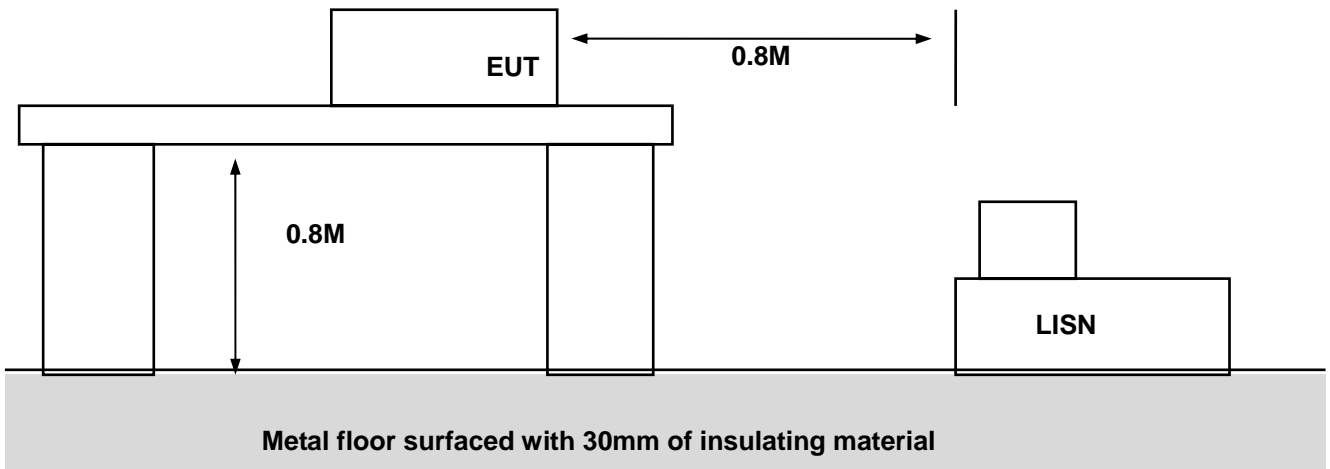

MEASUREMENT OF RADIATED EMISSION

