

MEASUREMENT REPORT

FCC PART 15C / RSS-247 WLAN 802.11n

FCC ID: HD5-CT40L1N
IC: 1693B-CT40L1N
APPLICANT: Honeywell International Inc
Honeywell Safety and Productivity Solutions
Application Type: Class Permissive Change
Product: DOLPHIN CT40
Model No.: CT40-L1N
Brand Name: Honeywell
FCC Classification: Digital Transmission System (DTS)
FCC Rule Part(s): Part 15 Subpart C (Section 15.247)
IC Rule(s): RSS-247 Issue 2, RSS-GEN Issue 5
Test Procedure(s): ANSI C63.10-2013, KDB 558074 D01v05r02
Test Date: September 17 ~ 22, 2019

Reviewed By:

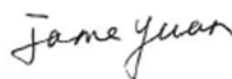

(Jame Yuan)

Approved By:

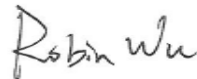

(Robin Wu)



The test results relate only to the samples tested.

This equipment has been shown to be capable of compliance with the applicable technical standards as indicated in the measurement report and was tested in accordance with the measurement procedures specified in ANSI C63.10-2013. Test results reported herein relate only to the item(s) tested.

The test report shall not be reproduced except in full without the written approval of MRT Technology (Suzhou) Co., Ltd.

Revision History

Report No.	Version	Description	Issue Date	Note
1909RSU018-U2	Rev. 01	Initial Report	09-23-2019	Valid

Note: This report was based on original MRT report no. 1909RSU018-U1 (Model: CT40-L0N) and retest the radiated spurious emission items. CT40-L1N added the LTE module on the basis of CT40-L0N, any others are the same.

CONTENTS

Description	Page
§2.1033 General Information	5
1. INTRODUCTION	6
1.1. Scope.....	6
1.2. MRT Test Location	6
2. PRODUCT INFORMATION	7
2.1. Equipment Description	7
2.2. Product Specification Subjective to this Report	7
2.3. Working Frequencies for this report.....	8
2.4. Test Mode	8
2.5. Description of Test Software.....	8
2.6. Device Capabilities.....	9
2.7. Test Configuration	10
2.8. EMI Suppression Device(s)/Modifications.....	10
2.9. Labeling Requirements.....	10
3. DESCRIPTION of TEST	11
3.1. Evaluation Procedure	11
3.2. AC Line Conducted Emissions	11
3.3. Radiated Emissions.....	12
4. ANTENNA REQUIREMENTS	13
5. TEST EQUIPMENT CALIBRATION DATE	14
6. MEASUREMENT UNCERTAINTY	16
7. TEST RESULT	17
7.1. Summary.....	17
7.2. 6dB & 99% Bandwidth Measurement	18
7.2.1. Test Limit	18
7.2.2. Test Procedure used.....	18
7.2.3. Test Setting.....	18
7.2.4. Test Setup	19
7.2.5. Test Result.....	20
7.3. Output Power Measurement.....	22
7.3.1. Test Limit	22
7.3.2. Test Procedure Used	22
7.3.3. Test Setting.....	22

7.3.4.	Test Setup	22
7.3.5.	Test Result of Output Power	23
7.4.	Power Spectral Density Measurement.....	25
7.4.1.	Test Limit	25
7.4.2.	Test Procedure Used	25
7.4.3.	Test Setting.....	25
7.4.4.	Test Setup	25
7.4.5.	Test Result.....	26
7.5.	Conducted Band Edge and Out-of-Band Emissions	28
7.5.1.	Test Limit	28
7.5.2.	Test Procedure Used	28
7.5.3.	Test Setting.....	28
7.5.4.	Test Setup	29
7.5.5.	Test Result.....	30
7.6.	Radiated Spurious Emission Measurement	33
7.6.1.	Test Limit	33
7.6.2.	Test Procedure Used	33
7.6.3.	Test Setting.....	33
7.6.4.	Test Setup	35
7.6.5.	Test Result.....	36
	The Worst Case of Radiated Emission below 1GHz:.....	39
7.7.	Radiated Restricted Band Edge Measurement.....	41
7.7.1.	Test Limit	41
7.7.2.	Test Procedure Used	44
7.7.3.	Test Setting.....	44
7.7.4.	Test Setup	45
7.7.5.	Test Result.....	46
7.8.	AC Conducted Emissions Measurement	54
7.8.1.	Test Limit	54
7.8.2.	Test Setup	54
7.8.3.	Test Result.....	55
8.	CONCLUSION	57
	Appendix A - Test Setup Photograph	58
	Appendix B - EUT Photograph.....	59

§2.1033 General Information

Applicant:	Honeywell International Inc Honeywell Safety and Productivity Solutions
Applicant Address:	9680 Old Bailes Road, Fort Mill, SC 29707 United States
Manufacturer:	Honeywell International Inc Honeywell Safety and Productivity Solutions
Manufacturer Address:	9680 Old Bailes Road, Fort Mill, SC 29707 United States
Test Site:	MRT Technology (Suzhou) Co., Ltd
Test Site Address:	D8 Building, No.2 Tian'edang Rd., Wuzhong Economic Development Zone, Suzhou, China
Test Device Serial No.:	N/A <input type="checkbox"/> Production <input checked="" type="checkbox"/> Pre-Production <input type="checkbox"/> Engineering

Test Facility / Accreditations

Measurements were performed at MRT Laboratory located in Tian'edang Rd., Suzhou, China.

- MRT facility is a FCC registered (MRT Reg. No. 893164) test facility with the site description report on file and has met all the requirements specified in ANSI C63.4-2014.
- MRT facility is an IC registered (MRT Reg. No. 11384A-1) test laboratory with the site description on file at Industry Canada.
- MRT facility is a VCCI registered (R-20025, G-20034, C-20020, T-20020) test laboratory with the site description on file at VCCI Council.
- MRT Lab is accredited to ISO 17025 by the American Association for Laboratory Accreditation (A2LA) under the American Association for Laboratory Accreditation Program (A2LA Cert. No. 3628.01) in EMC, Telecommunications, Radio and SAR testing.



1. INTRODUCTION

1.1. Scope

Measurement and determination of electromagnetic emissions (EMC) of radio frequency devices including intentional and/or unintentional radiators for compliance with the technical rules and regulations of the Federal Communications Commission and the Innovation, Science and Economic Development Canada and Certification and Engineering Bureau.

1.2. MRT Test Location

The map below shows the location of the MRT LABORATORY, its proximity to the Taihu Lake. These measurement tests were conducted at the MRT Technology (Suzhou) Co., Ltd. Facility located at D8 Building, No.2 Tian'edang Rd., Wuzhong Economic Development Zone, Suzhou, China. The detailed description of the measurement facility was found to be in compliance with the requirements of § 2.948 according to ANSI C63.4-2009 on September 30, 2013.



2. PRODUCT INFORMATION

2.1. Equipment Description

Product Name:	DOLPHIN CT40
Model No.:	CT40-L1N
Brand Name:	Honeywell
Hardware Version:	1.0
Software Version:	OS.03.003-HON.02.001
Wi-Fi Specification:	802.11a/b/g/n/ac
Bluetooth Version:	v5.0 dual mode
GSM Operation Band (s)	GSM900 / DCS1800
WCDMA Operation Band (s)	Band I/VIII
LTE Operation Band (s)	FDD Band 1/3/7/8/20/28, TDD Band 38/40
Accessories	
USB Adapter:	Model No.: ADS-12B-06 05010E Input Power: 100 - 240V ~ 50/60Hz, Max. 0.3A Output Power: 5VDC 2.0A
Snap-on Adapter:	Model No.: CT40-SN
Battery:	Model No.: CT50-BTSC Capacitance: 15.5Wh, 4090mAh Rated Voltage: 3.8V Limit Charge Voltage: 4.36V

2.2. Product Specification Subjective to this Report

Frequency Range:	802.11n-HT40: 2422 ~ 2452MHz
Channel Number:	802.11n-HT40: 7
Type of Modulation:	802.11n: OFDM
Data Rate:	802.11n: up to 150Mbps
Maximum Peak Output Power:	802.11n-HT40: 21.20dBm
Antenna Type:	FPC Antenna
Antenna Gain:	2.20dBi for 2.4GHz Band, 3.39dBi for 5GHz Band

Note: For other features of this EUT, test report will be issued separately.

2.3. Working Frequencies for this report

802.11n-HT40

Channel	Frequency	Channel	Frequency	Channel	Frequency
03	2422 MHz	04	2427 MHz	05	2432 MHz
06	2437 MHz	07	2442 MHz	08	2447 MHz
09	2452 MHz	--	--	--	--

2.4. Test Mode

Test Mode	Mode 1: Transmit by 802.11 n-HT40
-----------	-----------------------------------

2.5. Description of Test Software

The test utility software used during testing was “QRCT”, and the version was 3.0.268.0.

Power Parameter Value

Test Mode	Test Channel No.	Test Frequency (MHz)	Power Parameter Value
802.11n-HT40	03	2422	12.0
	06	2437	12.0
	09	2452	12.0

2.6. Device Capabilities

This device contains the following capabilities:

GSM & WCDMA & LTE & 2.4GHz WLAN, 5GHz WLAN & Bluetooth (v5.0 dual mode) & NFC

Note: 2.4GHz WLAN (DTS) operation is possible in 20MHz channel bandwidths. The maximum achievable duty cycles for all modes were determined based on measurements performed on a spectrum analyzer in zero-span mode with RBW = 8MHz, VBW = 50MHz. The RBW and VBW were both greater than 50/T, where T is the minimum transmission duration, and the number of sweep points across T was greater than 100. The duty cycles are as follows:

Test Mode	Duty Cycle
802.11n-HT40	85.51%

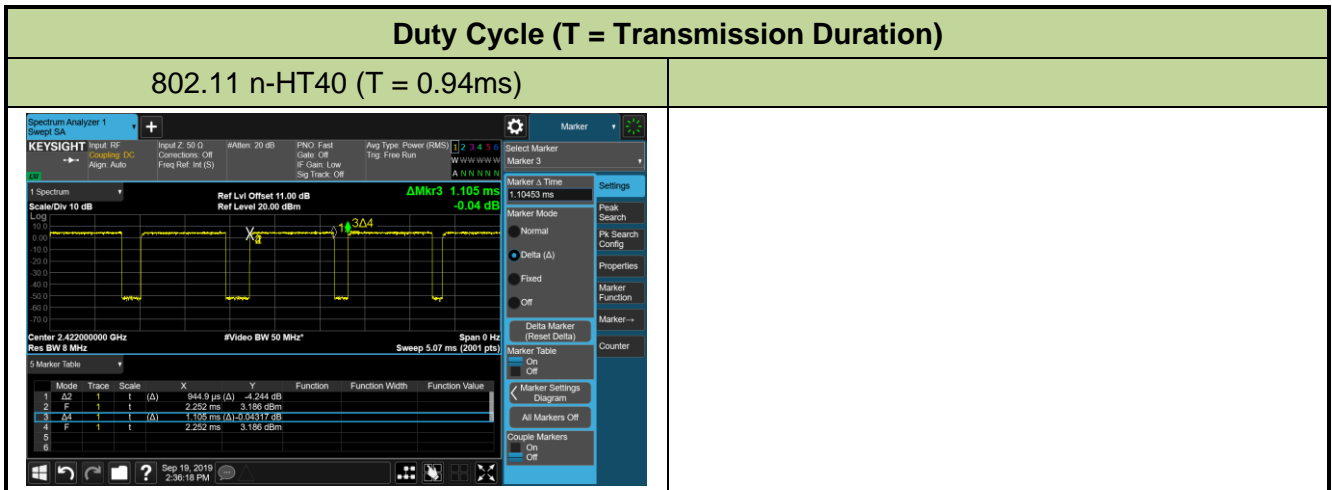

2.7. Test Configuration

The **DOLPHIN CT40** was tested per the guidance of ANSI C63.10-2013 was used to reference the appropriate EUT setup for radiated spurious emissions testing and AC line conducted testing.

2.8. EMI Suppression Device(s)/Modifications

No EMI suppression device(s) were added and/or no modifications were made during testing.

2.9. Labeling Requirements

Per 2.1074 & 15.19; Docket 95-19

The label shall be permanently affixed at a conspicuous location on the device; instruction manual or pamphlet supplied to the user and be readily visible to the purchaser at the time of purchase. However, when the device is so small wherein placement of the label with specified statement is not practical, only the FCC ID must be displayed on the device per Section 15.19(a)(5). Please see attachment for FCC ID label and label location.

RSP-100 Issue 11 Section 3

The manufacturer, importer or distributor shall meet the labelling requirements set out in this section for every unit:

- (i) prior to marketing in Canada, for products manufactured in Canada
- (ii) prior to importation into Canada, for imported products

For information regarding the e-labelling option, see Notice 2014-DRS1003. The label for the certified product represents the manufacturer's or importer's compliance with Innovation, Science and Economic Development Canada's (ISED) regulatory requirements.

Please see attachment for IC label and label location.

3. DESCRIPTION of TEST

3.1. Evaluation Procedure

The measurement procedures described in the American National Standard of Procedures for Compliance Testing of Unlicensed Wireless Devices (ANSI C63.10-2013), and the guidance provided in KDB 558074 D01v05r02 were used in the measurement.

Deviation from measurement procedure.....None

3.2. AC Line Conducted Emissions

The line-conducted facility is located inside an 8'x4'x4' shielded enclosure. A 1m x 2m wooden table 80cm high is placed 40cm away from the vertical wall and 80cm away from the sidewall of the shielded room. Two 10kHz-30MHz, 50Ω/50uH Line-Impedance Stabilization Networks (LISNs) are bonded to the shielded room floor. Power to the LISNs is filtered by external high-current high-insertion loss power line filters. These filters attenuate ambient signal noise from entering the measurement lines. These filters are also bonded to the shielded enclosure.

The EUT is powered from one LISN and the support equipment is powered from the second LISN. All interconnecting cables more than 1 meter were shortened to a 1 meter length by non-inductive bundling (serpentine fashion) and draped over the back edge of the test table. All cables were at least 40cm above the horizontal reference ground-plane. Power cables for support equipment were routed down to the second LISN while ensuring that that cables were not draped over the second LISN.

Sufficient time for the EUT, support equipment, and test equipment was allowed in order for them to warm up to their normal operating condition. The RF output of the LISN was connected to the receiver and exploratory measurements were made to determine the frequencies producing the maximum emission from the EUT. The receiver was scanned from 150kHz to 30MHz. The detector function was set to peak mode for exploratory measurements while the bandwidth of the analyzer was set to 9kHz. The EUT, support equipment, and interconnecting cables were arranged and manipulated to maximize each emission. Each emission was also maximized by varying: power lines, the mode of operation or data exchange speed, or support equipment which determined the worst-case emission. Once the worst case emissions have been identified, the one EUT cable configuration/arrangement and mode of operation that produced these emissions are used for final measurements on the same test site. The analyzer is set to CISPR quasi-peak and average detectors with a 9kHz resolution bandwidth for final measurements.

An extension cord was used to connect to a single LISN which powered by EUT. The extension cord was calibrated with LISN, the impedance and insertion loss are compliance with the requirements as stated in ANSI C63.10-2013.

3.3. Radiated Emissions

The radiated test facilities consisted of an indoor 3 meter semi-anechoic chamber used for final measurements and exploratory measurements, when necessary. The measurement area is contained within the semi-anechoic chamber which is shielded from any ambient interference. For measurements above 1GHz absorbers are arranged on the floor between the turn table and the antenna mast in such a way so as to maximize the reduction of reflections. For measurements below 1GHz, the absorbers are removed. A MF Model 210SS turntable is used for radiated measurement. It is a continuously rotatable, remote controlled, metallic turntable and 2 meters (6.56 ft.) in diameter. The turn table is flush with the raised floor of the chamber in order to maintain its function as a ground plane. An 80cm high PVC support structure is placed on top of the turntable.

For all measurements, the spectrum was scanned through all EUT azimuths and from 1 to 4 meter receive antenna height using a broadband antenna from 30MHz up to the upper frequency shown in 15.33(b)(1) depending on the highest frequency generated or used in the device or on which the device operates or tunes. For frequencies above 1GHz, linearly polarized double ridge horn antennas were used. For frequencies below 30MHz, a calibrated loop antenna was used. When exploratory measurements were necessary, they were performed at 1 meter test distance inside the semi-anechoic chamber using broadband antennas, broadband amplifiers, and spectrum analyzers to determine the frequencies and modes producing the maximum emissions. Sufficient time for the EUT, support equipment, and test equipment was allowed in order for them to warm up to their normal operating condition. The test set-up for frequencies below 1GHz was placed on top of the 0.8 meter high, 1 x 1.5 meter table; and test set-up for frequencies 1-40GHz was placed on top of the 1.5 meter high, 1 x 1.5 meter table. The EUT, support equipment, and interconnecting cables were arranged and manipulated to maximize each emission. Appropriate precaution was taken to ensure that all emissions from the EUT were maximized and investigated. The system configuration, clock speed, mode of operation or video resolution, if applicable, turntable azimuth, and receive antenna height was noted for each frequency found.

Final measurements were made in the semi-anechoic chamber using calibrated, linearly polarized broadband and horn antennas. The test setup was configured to the setup that produced the worst case emissions. The spectrum analyzer was set to investigate all frequencies required for testing to compare the highest radiated disturbances with respect to the specified limits. The turntable containing the EUT was rotated through 360 degrees and the height of the receive antenna was varied 1 to 4 meters and stopped at the azimuth and height producing the maximum emission. Each emission was maximized by changing the orientation of the EUT through three orthogonal planes and changing the polarity of the receive antenna, which produced the worst-case emissions. According to 3dB Beam-Width of horn antenna, the horn antenna should be always directed to the EUT when rising height.

4. ANTENNA REQUIREMENTS

Excerpt from §15.203 of the FCC Rules/Regulations:

“An intentional radiator antenna shall be designed to ensure that no antenna other than that furnished by the responsible party can be used with the device. The use of a permanently attached antenna or of an antenna that uses a unique coupling to the intentional radiator shall be considered sufficient to comply with the provisions of this section.”

- The antenna of the device is **permanently attached**.
- There are no provisions for connection to an external antenna.

Conclusion:

The unit complies with the requirement of §15.203.

5. TEST EQUIPMENT CALIBRATION DATE

Conducted Emissions - SR2

Instrument	Manufacturer	Type No.	Asset No.	Cali. Interval	Cali. Due Date
EMI Test Receiver	R&S	ESR3	MRTSUE06185	1 year	2020/04/15
Two-Line V-Network	R&S	ENV 216	MRTSUE06002	1 year	2020/06/13
Two-Line V-Network	R&S	ENV 216	MRTSUE06003	1 year	2020/06/13
Thermohygrometer	Testo	608-H1	MRTSUE06404	1 year	2020/08/08
Shielding Room	MIX-BEP	Chamber-SR2	MRTSUE06215	N/A	N/A

Radiated Emissions - AC1

Instrument	Manufacturer	Type No.	Asset No.	Cali. Interval	Cali. Due Date
EMI Test Receiver	R&S	ESR7	MRTSUE06001	1 year	2020/08/01
PXA Signal Analyzer	Keysight	9030B	MRTSUE06395	1 year	2019/09/25
Loop Antenna	Schwarzbeck	FMZB 1519	MRTSUE06025	1 year	2019/11/09
Bilog Period Antenna	Schwarzbeck	VULB 9168	MRTSUE06172	1 year	2020/03/31
Broad Band Horn Antenna	Schwarzbeck	BBHA 9120D	MRTSUE06023	1 year	2019/10/19
Broad Band Horn Antenna	Schwarzbeck	BBHA 9170	MRTSUE06024	1 year	2019/12/17
Microwave System Amplifier	Agilent	83017A	MRTSUE06076	1 year	2019/11/16
Preamplifier	Schwarzbeck	BBV 9721	MRTSUE06121	1 year	2020/06/11
Thermohygrometer	Testo	608-H1	MRTSUE06403	1 year	2020/08/08
Anechoic Chamber	TDK	Chamber-AC1	MRTSUE06212	1 year	2020/04/30

Radiated Emission - AC2

Instrument	Manufacturer	Type No.	Asset No.	Cali. Interval	Cali. Due Date
Spectrum Analyzer	Keysight	N9038A	MRTSUE06125	1 year	2020/08/01
Loop Antenna	Schwarzbeck	FMZB 1519	MRTSUE06025	1 year	2019/11/09
Bilog Period Antenna	Schwarzbeck	VULB 9162	MRTSUE06022	1 year	2019/10/19
Horn Antenna	Schwarzbeck	BBHA9120D	MRTSUE06171	1 year	2019/11/09
Broad Band Horn Antenna	Schwarzbeck	BBHA 9170	MRTSUE06024	1 year	2019/12/17
Broadband Coaxial Preamplifier	Schwarzbeck	BBV 9718	MRTSUE06176	1 year	2019/11/16
Preamplifier	Schwarzbeck	BBV 9721	MRTSUE06121	1 year	2020/06/11
Temperature/Humidity Meter	Minggao	ETH529	MRTSUE06170	1 year	2019/12/13
Anechoic Chamber	RIKEN	Chamber-AC2	MRTSUE06213	1 year	2020/04/30

Conducted Test Equipment - TR3

Instrument	Manufacturer	Type No.	Asset No.	Cali. Interval	Cali. Due Date
EXA Signal Analyzer	Agilent	N9020A	MRTSUE06106	1 year	2020/04/15
EXA Signal Analyzer	Keysight	N9010B	MRTSUE06452	1 year	2020/07/11
Signal Analyzer	R&S	FSV40	MRTSUE06218	1 year	2020/04/15
Power Meter	Agilent	U2021XA	MRTSUE06030	1 year	2019/11/16
USB wideband power sensor	Keysight	U2021XA	MRTSUE06446	1 year	2020/06/30
USB wideband power sensor	Keysight	U2021XA	MRTSUE06447	1 year	2020/06/30
Bluetooth Test Set	Anritsu	MT8852B-042	MRTSUE06389	1 year	2020/06/13
Audio Analyzer	Agilent	U8903B	MRTSUE06143	1 year	2020/06/13
Modulation Analyzer	HP	8901A	MRTSUE06098	1 year	2019/10/18
Wideband Radio Communication Tester	R&S	CMW 500	MRTSUE06243	1 year	2019/11/16
DC Power Supply	GWINSTEK	DPS-3303C	MRTSUE06064	N/A	N/A
Temperature & Humidity Chamber	BAOYT	BYH-150CL	MRTSUE06051	1 year	2019/11/16
Thermohygrometer	testo	608-H1	MRTSUE06401	1 year	2020/08/08

Software	Version	Function
EMI Software	V3	EMI Test Software

6. MEASUREMENT UNCERTAINTY

Where relevant, the following test uncertainty levels have been estimated for tests performed on the EUT as specified in CISPR 16-4-2. This uncertainty represents an expanded uncertainty expressed at approximately the 95% confidence level using a coverage factor of $k = 2$.

Conducted Emission Measurement - SR2
<p>The maximum measurement uncertainty is evaluated as:</p> <p>9kHz~150kHz: 3.84dB</p> <p>150kHz~30MHz: 3.46dB</p>
Radiated Emission Measurement - AC1
<p>The maximum measurement uncertainty is evaluated as:</p> <p>Horizontal: 30MHz~300MHz: 4.07dB</p> <p style="padding-left: 40px;">300MHz~1GHz: 3.63dB</p> <p style="padding-left: 40px;">1GHz~18GHz: 4.16dB</p> <p>Vertical: 30MHz~300MHz: 4.18dB</p> <p style="padding-left: 40px;">300MHz~1GHz: 3.60dB</p> <p style="padding-left: 40px;">1GHz~18GHz: 4.76dB</p>
Radiated Emission Measurement - AC2
<p>The maximum measurement uncertainty is evaluated as:</p> <p>Horizontal: 30MHz~300MHz: 3.75dB</p> <p style="padding-left: 40px;">300MHz~1GHz: 3.53dB</p> <p style="padding-left: 40px;">1GHz~18GHz: 4.28dB</p> <p>Vertical: 30MHz~300MHz: 3.86dB</p> <p style="padding-left: 40px;">300MHz~1GHz: 3.53dB</p> <p style="padding-left: 40px;">1GHz~18GHz: 4.33dB</p>

7. TEST RESULT

7.1. Summary

FCC Part Section(s)	RSS Section(s)	Test Description	Test Limit	Test Condition	Test Result	Reference
15.247(a)(2)	RSS-247 [5.2]	6dB Bandwidth	$\geq 500\text{kHz}$	Conducted	Pass	Section 7.2
15.247(b)(3)	RSS-247 [5.4(d)]	Output Power	$\leq 1\text{Watt}$ & $\text{EIRP} \leq 4\text{Watt}$		Pass	Section 7.3
15.247(e)	RSS-247 [5.2]	Power Spectral Density	$\leq 8\text{dBm} / 3\text{kHz}$		Pass	Section 7.4
15.247(d)	RSS-247 [5.5]	Band Edge / Out-of-Band Emissions	$\geq 20\text{dBc(Peak)}$		Pass	Section 7.5
15.205 15.209	RSS-247 [5.5]	General Field Strength Limits (Restricted Bands and Radiated Emission Limits)	Emissions in restricted bands must meet the radiated limits detailed in 15.209	Radiated	Pass	Section 7.6&7.7
15.207	RSS-Gen [8.8]	AC Conducted Emissions 150kHz - 30MHz	$< \text{FCC } 15.207$ limits	Line Conducted	Pass	Section 7.8

Notes:

- 1) The analyzer plots shown in this section were all taken with a correction table loaded into the analyzer. The correction table was used to account for the losses of the cables and attenuators used as part of the system to connect the EUT to the analyzer at all frequencies of interest.
- 2) All modes of operation and data rates were investigated. For radiated emission test, every axis (X, Y, Z) was also verified. The test results shown in the following sections represent the worst case emissions.

7.2. 6dB & 99% Bandwidth Measurement

7.2.1. Test Limit

The minimum 6dB bandwidth shall be at least 500 kHz.

7.2.2. Test Procedure used

ANSI C63.10-2013 - Section 11.8 (6dB bandwidth)

ANSI C63.10-2013 - Section 6.9.3 (99% bandwidth)

7.2.3. Test Setting

6dB Occupied Bandwidth

1. The Spectrum's automatic bandwidth measurement capability was used to perform the 6dB bandwidth measurement. The "X" dB bandwidth parameter was set to $X = 6$. The bandwidth measurement was not influenced by any intermediate power nulls in the fundamental emission.
2. Set RBW = 100 kHz
3. $VBW \geq 3 \times RBW$
4. Detector = Peak
5. Trace mode = max hold
6. Sweep = auto couple
7. Allow the trace was allowed to stabilize

99% Occupied Bandwidth

1. Span = 1.5 times to 5 times the OBW
2. Set RBW = 1% to 5% the OBW
3. $VBW \geq 3 \times RBW$
4. Detector = Peak
5. Trace mode = Max hold
6. Sweep = Auto couple
7. Allow the trace was allowed to stabilize

7.2.4. Test Setup

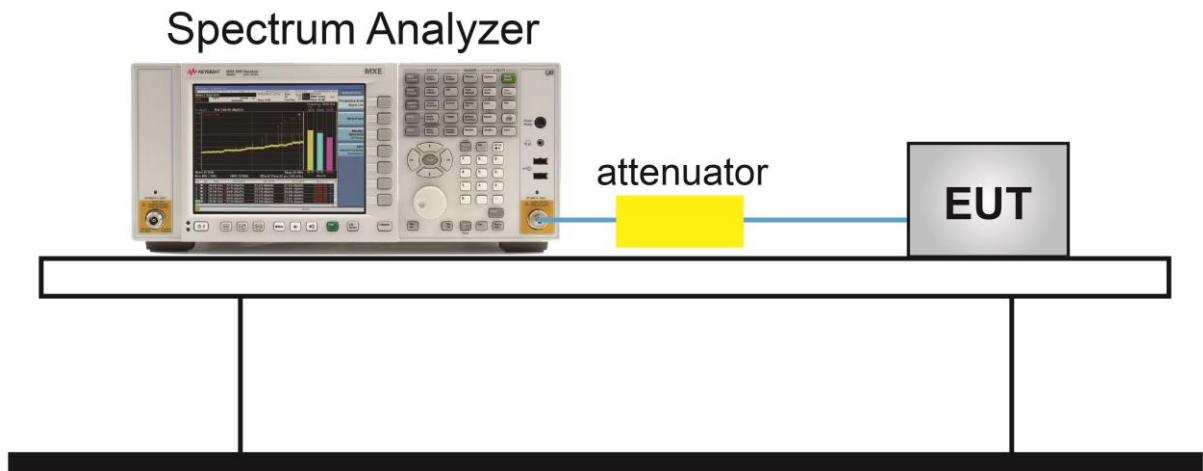

7.2.5. Test Result

Product	DOLPHIN CT40	Temperature	25°C
Test Engineer	Snake Ni	Relative Humidity	52%
Test Site	TR3	Test Date	2019/09/19

Test Mode	Data Rate / MCS	Channel No.	Frequency (MHz)	6dB Bandwidth (MHz)	Limit (MHz)	99% Bandwidth (MHz)	Result
802.11n-HT40	MCS0	03	2422	35.77	≥ 0.5	37.09	Pass
802.11n-HT40	MCS0	06	2437	35.49	≥ 0.5	36.82	Pass
802.11n-HT40	MCS0	09	2452	36.35	≥ 0.5	37.59	Pass

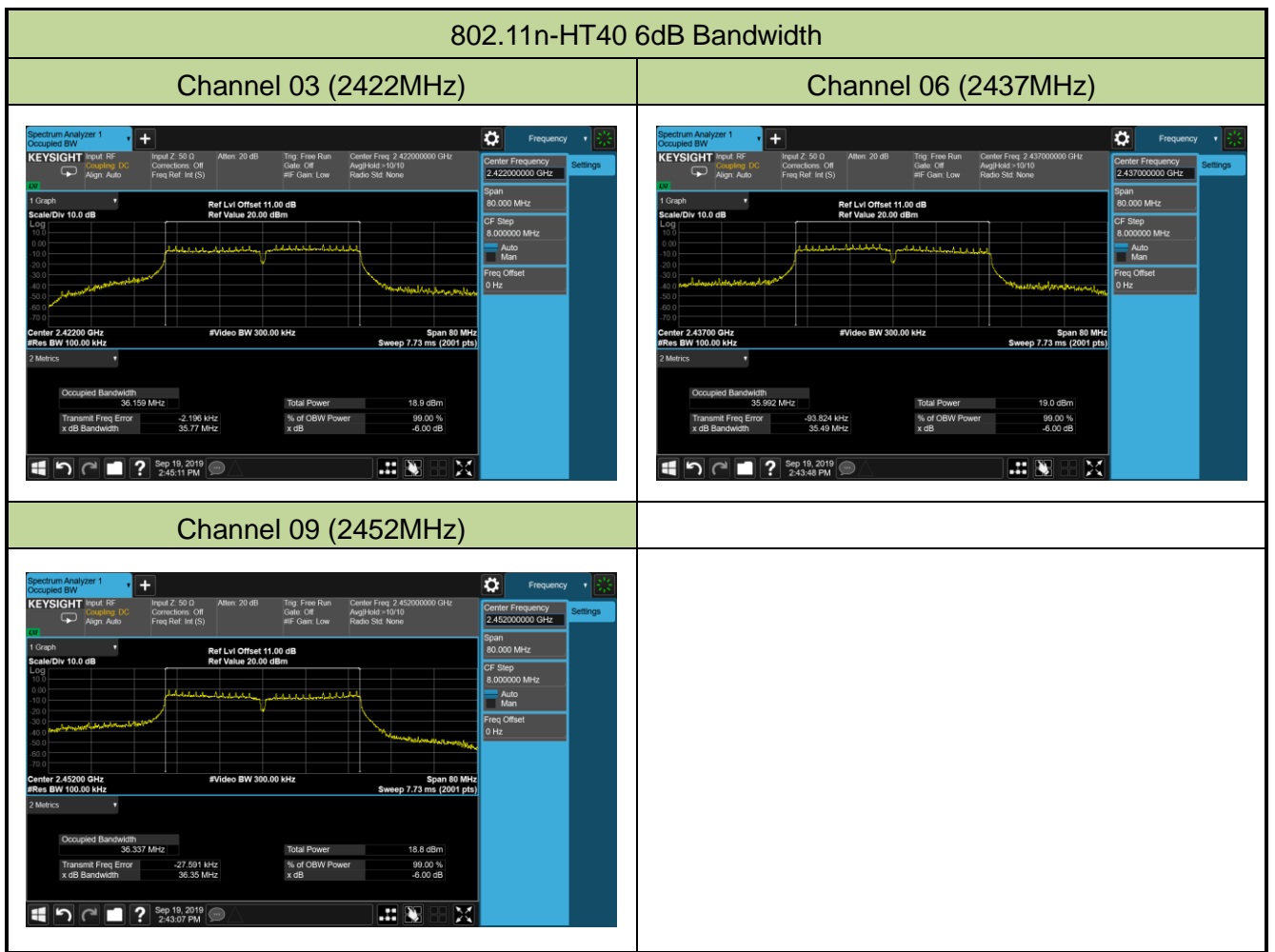

802.11n-HT40 99% Bandwidth

Channel 03 (2422MHz)

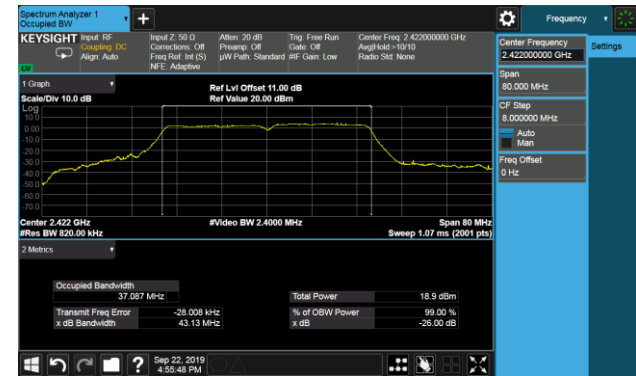

Channel 06 (2437MHz)



Channel 09 (2452MHz)

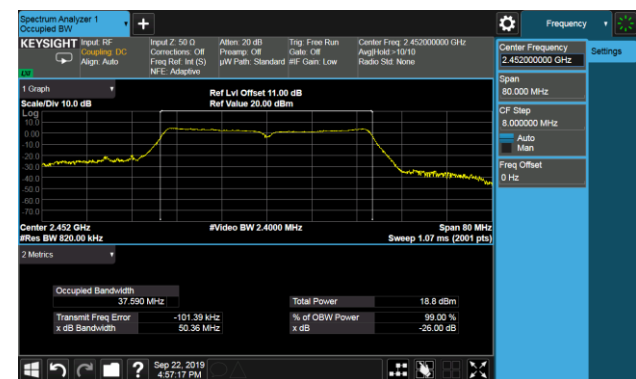

7.3. Output Power Measurement

7.3.1. Test Limit

The maximum conducted output power shall be exceed 1 Watt (30dBm) and the E.I.R.P shall not exceed 4 Watt (36dBm).

7.3.2. Test Procedure Used

ANSI C63.10 - Section 11.9.1.3

ANSI C63.10 - Section 11.9.2.3

7.3.3. Test Setting

Method PKPM1 (Peak Power Measurement)

Peak power measurements were performed only when the EUT was transmitting at its maximum power control level using a broadband power meter with a pulse sensor. The pulse sensor employs a VBW = 50MHz so this method was only used for signals whose DTS bandwidth was less than or equal to 50MHz.

Method AVGPM-G (Measurement using a gated RF average-reading power meter)

Measurements may be performed using a wideband gated RF power meter provided that the gate parameters are adjusted such that the power is measured only when the EUT is transmitting at its maximum power control level. Since this measurement is made only during the ON time of the transmitter, no duty cycle correction is required.

7.3.4. Test Setup

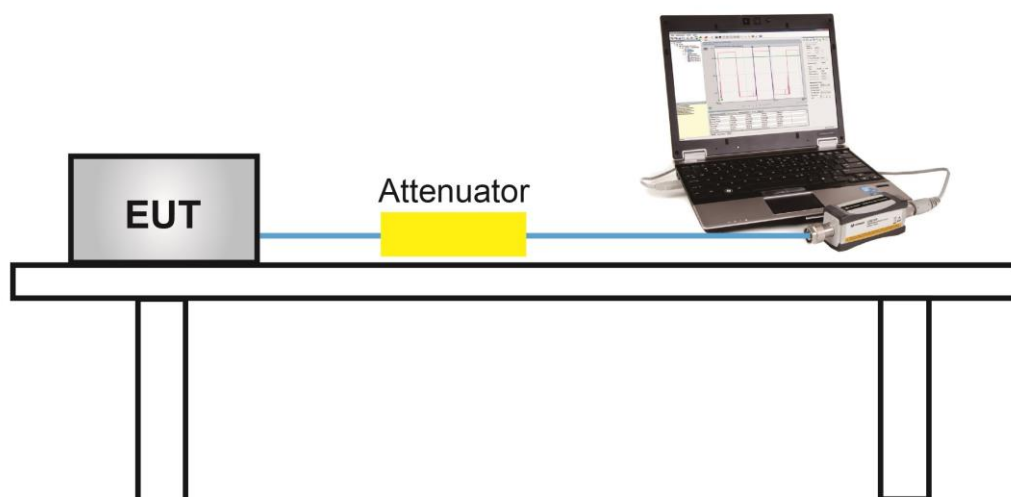

7.3.5. Test Result of Output Power

Power output test was verified over all data rates of each mode shown as below, and then choose the maximum power output (gray marker) for final test of each channel.

Test Mode	Bandwidth (MHz)	Channel No.	Frequency (MHz)	Data Rate / MCS	Average Power (dBm)
802.11n	40	6	2437	MCS0	12.06
				MCS3	11.89
				MCS7	11.70

Product	DOLPHIN CT40	Temperature	25°C
Test Engineer	Snake Ni	Relative Humidity	52%
Test Site	TR3	Test Date	2019/09/19

Test Result of Peak Output Power

Test Mode	Data Rate / MCS	Channel No.	Freq. (MHz)	Peak Power (dBm)	Limit (dBm)	E.I.R.P (dBm)	E.I.R.P Limit (dBm)	Result
11n-HT40	MCS0	03	2422	21.05	≤ 30.00	23.25	≤ 36.00	Pass
11n-HT40	MCS0	06	2437	21.20	≤ 30.00	23.40	≤ 36.00	Pass
11n-HT40	MCS0	09	2452	21.04	≤ 30.00	23.24	≤ 36.00	Pass

Note: E.I.R.P (dBm) = Peak Power (dBm) + Antenna Gain (dBi)

Test Result of Average Output Power (Reporting Only)

Test Mode	Data Rate / MCS	Channel No.	Freq. (MHz)	Average Power (dBm)	Limit (dBm)	E.I.R.P (dBm)	E.I.R.P Limit (dBm)	Result
11n-HT40	MCS0	03	2422	11.83	≤ 30.00	14.03	≤ 36.00	Pass
11n-HT40	MCS0	06	2437	12.06	≤ 30.00	14.26	≤ 36.00	Pass
11n-HT40	MCS0	09	2452	11.80	≤ 30.00	14.00	≤ 36.00	Pass

Note: E.I.R.P (dBm) = Average Power (dBm) + Antenna Gain (dBi)

7.4. Power Spectral Density Measurement

7.4.1. Test Limit

The maximum permissible power spectral density is 8dBm in any 3 kHz band.

The same method of determining the conducted output power shall be used to determine the power spectral density.

7.4.2. Test Procedure Used

ANSI C63.10 - Section 11.10.2

7.4.3. Test Setting

1. Analyzer was set to the center frequency of the DTS channel under investigation
2. Span = 1.5 times the DTS channel bandwidth
3. RBW = 3kHz
4. VBW = 10kHz
5. Detector = peak
6. Sweep time = auto couple
7. Trace mode = max hold
8. Trace was allowed to stabilize

7.4.4. Test Setup

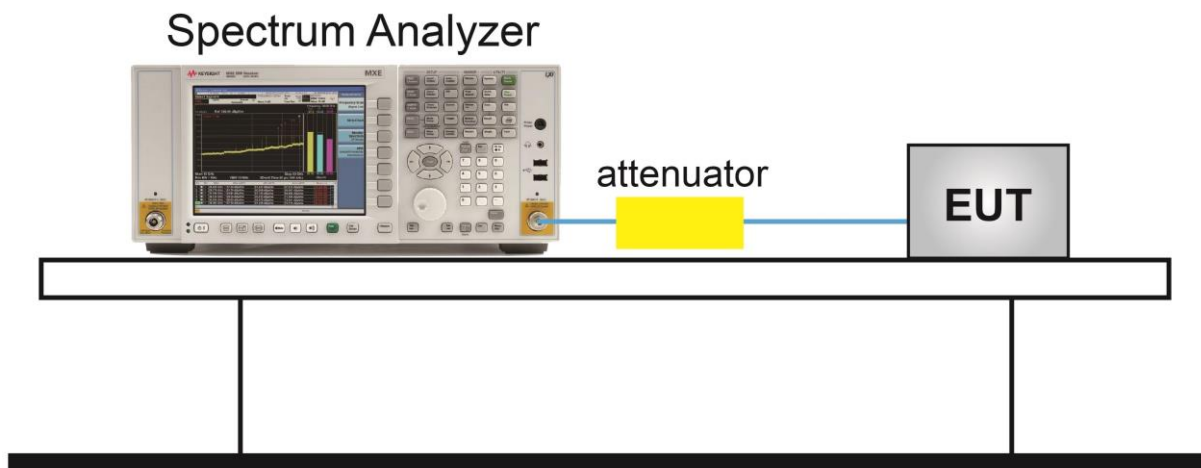

7.4.5. Test Result

Product	DOLPHIN CT40	Temperature	25°C
Test Engineer	Snake Ni	Relative Humidity	52%
Test Site	TR3	Test Date	2019/09/19

Test Mode	Data Rate / MCS	Channel No.	Freq. (MHz)	PK PSD (dBm / 3kHz)	Limit (dBm / 3kHz)	Result
11n-HT40	MCS0	03	2422	-16.53	≤ 8.00	Pass
11n-HT40	MCS0	06	2437	-16.95	≤ 8.00	Pass
11n-HT40	MCS0	09	2452	-16.38	≤ 8.00	Pass

802.11n-HT40 - PK PSD

Channel 03 (2422MHz)

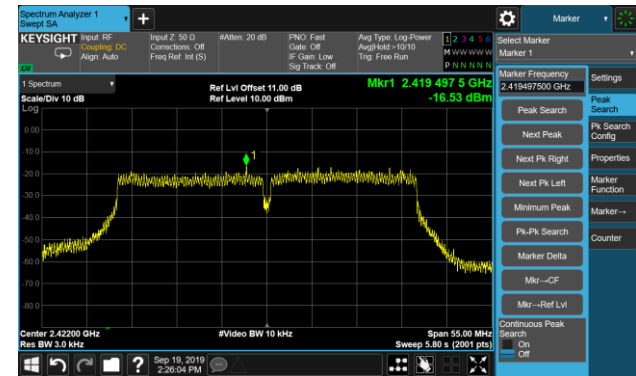

Channel 06 (2437MHz)

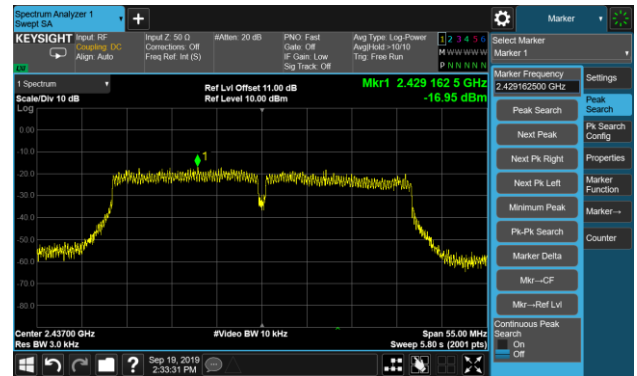

Channel 09 (2452MHz)

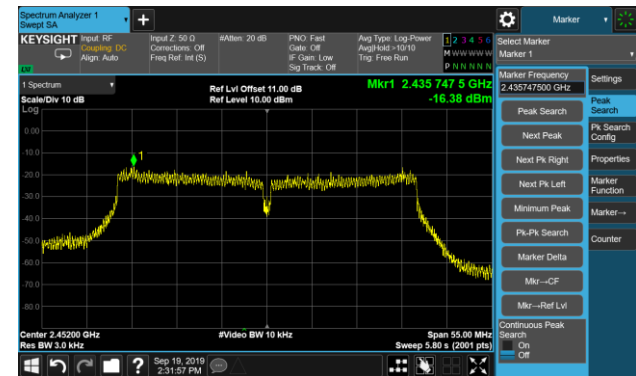

7.5. Conducted Band Edge and Out-of-Band Emissions

7.5.1. Test Limit

The limit for out-of-band spurious emissions at the band edge is 20dB below the fundamental emission level, as determined from the in-band power measurement of the DTS channel performed in a 100 kHz bandwidth per the PSD procedure.

7.5.2. Test Procedure Used

ANSI C63.10 - Section 11.11

7.5.3. Test Setting

Reference level measurement

1. Set instrument center frequency to DTS channel center frequency
2. Set the span to ≥ 1.5 times the DTS bandwidth
3. Set the RBW = 100 kHz
4. Set the VBW $\geq 3 \times$ RBW
5. Detector = peak
6. Sweep time = auto couple
7. Trace mode = max hold
8. Allow trace to fully stabilize

Emission level measurement

1. Set the center frequency and span to encompass frequency range to be measured
2. RBW = 100kHz
3. VBW = 300kHz
4. Detector = Peak
5. Trace mode = max hold
6. Sweep time = auto couple
7. The trace was allowed to stabilize

7.5.4. Test Setup

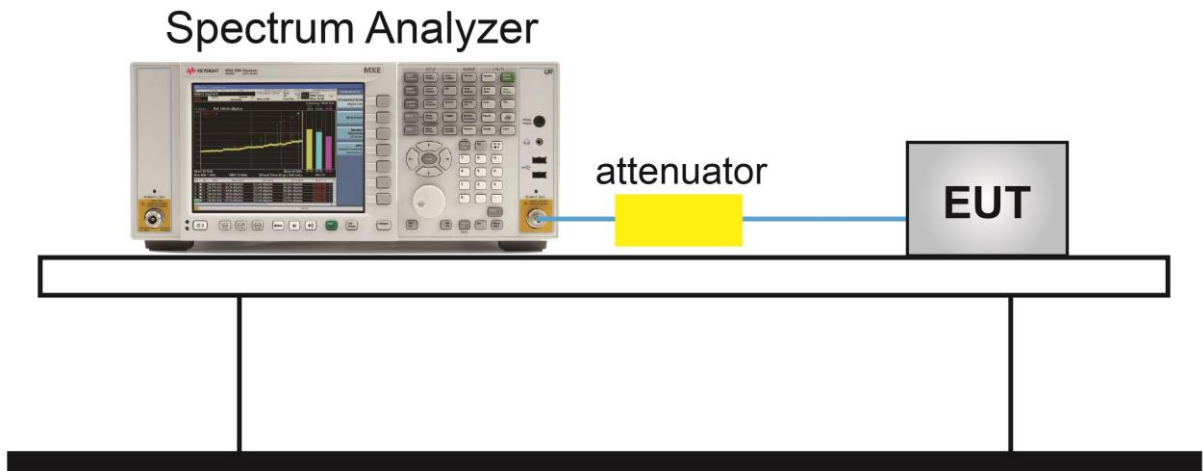

7.5.5. Test Result

Product	DOLPHIN CT40	Temperature	25°C
Test Engineer	Snake Ni	Relative Humidity	52%
Test Site	TR3	Test Date	2019/09/19

Test Mode	Data Rate / MCS	Channel No.	Frequency (MHz)	Limit	Result
802.11n-HT40	MCS0	03	2422	20dBc	Pass
802.11n-HT40	MCS0	06	2437	20dBc	Pass
802.11n-HT40	MCS0	09	2452	20dBc	Pass

802.11n-HT40 Out-of-Band Emissions Channel 03 (2422MHz)

100kHz PSD Reference Level

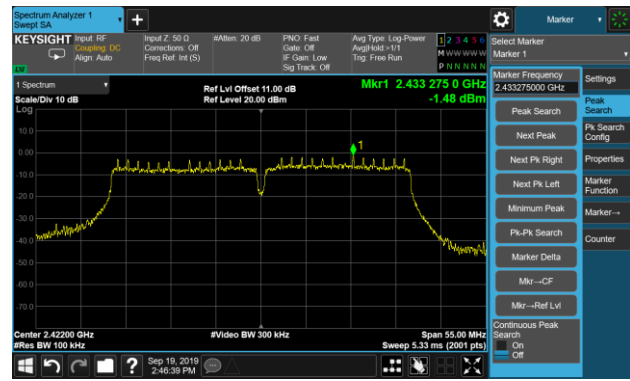

Low Band Edge



Spurious Emission



Note: The Value of the Display Line is -21.48dBm

Channel 06 (2437MHz)

100kHz PSD Reference Level



Spurious Emission



Note: The Value of the Display Line is -20.96dBm

802.11n-HT40 Out-of-Band Emissions Channel 09 (2452MHz)

100kHz PSD Reference Level

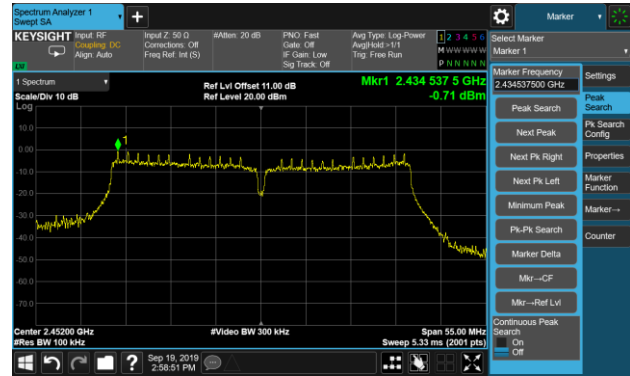

High Band Edge

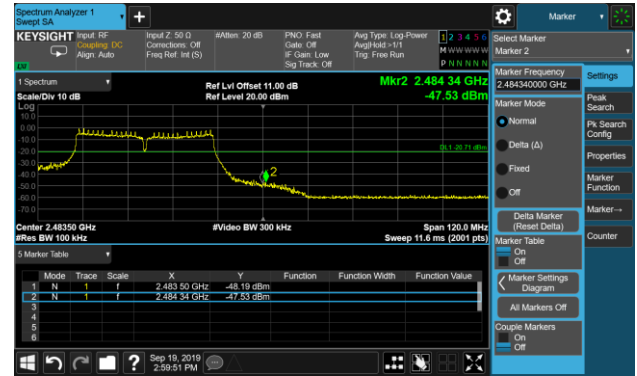

Spurious Emission



Note: The Value of the Display Line is -20.71dBm

7.6. Radiated Spurious Emission Measurement

7.6.1. Test Limit

All out of band emissions appearing in a restricted band as specified in Section 15.205 of the Title 47 CFR must not exceed the limits shown in Table per Section 15.209.

FCC Part 15 Subpart C Paragraph 15.209		
Frequency [MHz]	Field Strength [uV/m]	Measured Distance [Meters]
0.009 - 0.490	2400/F (kHz)	300
0.490 - 1.705	24000/F (kHz)	30
1.705 - 30	30	30
30 - 88	100	3
88 - 216	150	3
216 - 960	200	3
Above 960	500	3

7.6.2. Test Procedure Used

ANSI C63.10 - Section 6.3 (General Requirements)

ANSI C63.10 - Section 6.4 (Standard test method below 30MHz)

ANSI C63.10 - Section 6.5 (Standard test method above 30MHz to 1GHz)

ANSI C63.10 - Section 6.6 (Standard test method above 1GHz)

7.6.3. Test Setting

Table 1 - RBW as a function of frequency

Frequency	RBW
9 ~ 150 kHz	200 ~ 300 Hz
0.15 ~ 30 MHz	9 ~ 10 kHz
30 ~ 1000 MHz	100 ~ 120 kHz

Quasi-Peak Measurements below 1GHz

1. Analyzer center frequency was set to the frequency of the radiated spurious emission of interest
2. Span was set greater than 1MHz
3. RBW = as specified in Table 1
4. Detector = CISPR quasi-peak
5. Sweep time = auto couple
6. Trace was allowed to stabilize

Peak Measurements above 1GHz

1. Analyzer center frequency was set to the frequency of the radiated spurious emission of interest
2. RBW = 1MHz
3. VBW = 3MHz
4. Detector = peak
5. Sweep time = auto couple
6. Trace mode = max hold
7. Trace was allowed to stabilize

Average Measurements above 1GHz (Method VB)

1. Analyzer center frequency was set to the frequency of the radiated spurious emission of interest
2. RBW = 1MHz
3. VBW; If the EUT is configured to transmit with duty cycle $\geq 98\%$, set VBW = 10 Hz.
If the EUT duty cycle is $< 98\%$, set VBW $\geq 1/T$. T is the minimum transmission duration.
4. Detector = Peak
5. Sweep time = auto
6. Trace mode = max hold
7. Trace was allowed to stabilize

7.6.4. Test Setup

Below 1GHz Test Setup:

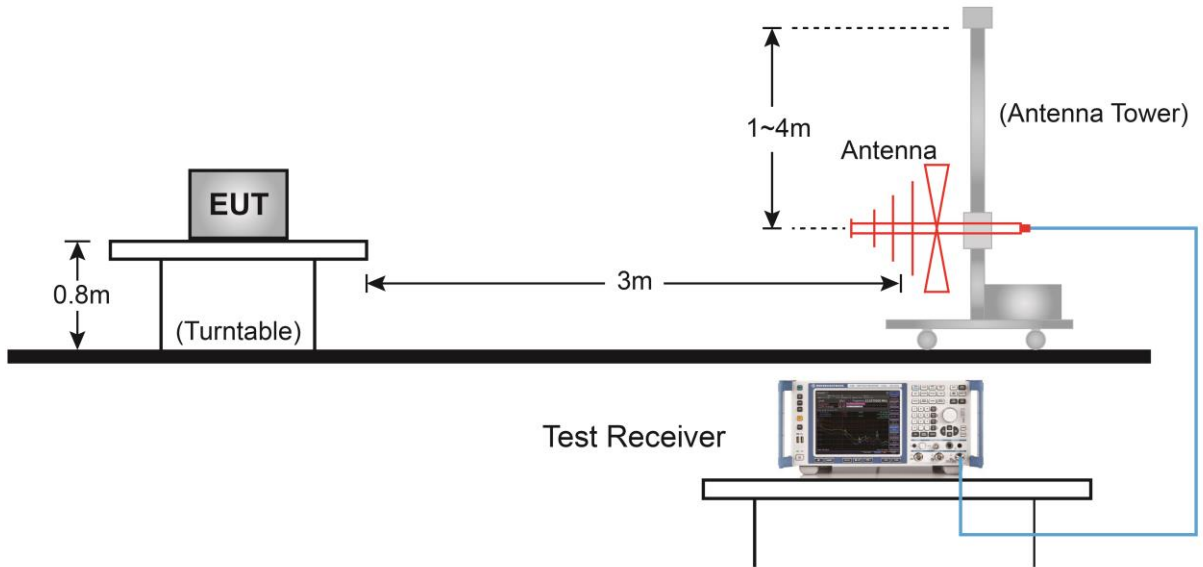

Above 1GHz Test Setup:

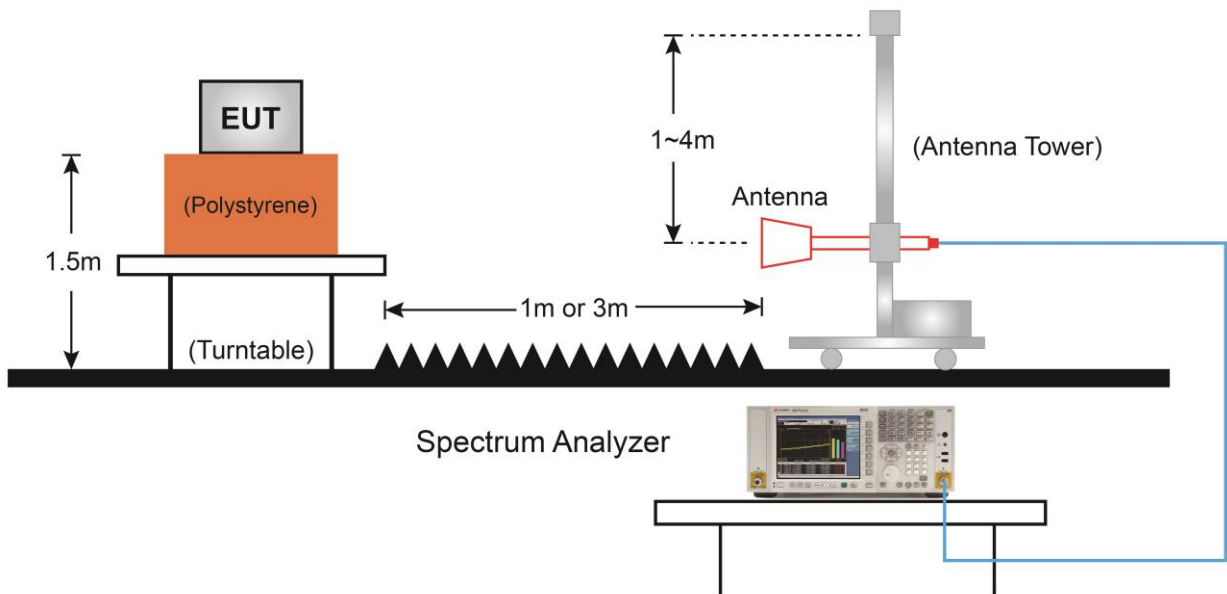

7.6.5. Test Result

Product	DOLPHIN CT40	Temperature	25°C
Test Engineer	Larry Yan	Relative Humidity	58%
Test Site	AC1	Test Date	2019/09/19
Test Mode:	802.11n-HT40	Test Channel:	03
Remark:	1. Average measurement was not performed if peak level lower than average limit. 2. Other frequency was 20dB below limit line within 1-18GHz, there is not show in the report.		

Mark	Frequency (MHz)	Reading Level (dBμV)	Factor (dB)	Measure Level (dBμV/m)	Limit (dBμV/m)	Margin (dB)	Detector	Polarization
	5054.5	36.5	6.3	42.8	74.0	-31.2	Peak	Horizontal
	7256.0	36.9	11.6	48.5	74.0	-25.5	Peak	Horizontal
*	7927.5	35.9	12.5	48.4	76.9	-28.5	Peak	Horizontal
*	8820.0	36.1	13.4	49.5	76.9	-27.4	Peak	Horizontal
	3788.0	38.2	1.9	40.0	74.0	-34.0	Peak	Vertical
	4740.0	37.4	5.4	42.8	74.0	-31.2	Peak	Vertical
*	5913.0	36.1	7.3	43.4	76.9	-33.5	Peak	Vertical
*	8845.5	35.6	13.4	48.9	76.9	-28.0	Peak	Vertical

Note 1: "*" is not in restricted band, its limit is 20dBc of the fundamental emission level (96.9dBμV/m) or FCC 15.209 which is higher.

Note 2: Measure Level (dBμV/m) = Reading Level (dBμV) + Factor (dB)

Factor (dB) = Cable Loss (dB) + Antenna Factor (dB/m) - Pre_Amplifier Gain (dB)

Product	DOLPHIN CT40	Temperature	25°C
Test Engineer	Larry Yan	Relative Humidity	58%
Test Site	AC1	Test Date	2019/09/19
Test Mode:	802.11n-HT40	Test Channel:	06
Remark:	1. Average measurement was not performed if peak level lower than average limit. 2. Other frequency was 20dB below limit line within 1-18GHz, there is not show in the report.		

Mark	Frequency (MHz)	Reading Level (dBμV)	Factor (dB)	Measure Level (dBμV/m)	Limit (dBμV/m)	Margin (dB)	Detector	Polarization
	4247.0	38.7	3.3	42.0	74.0	-32.0	Peak	Horizontal
	5071.5	37.2	6.4	43.6	74.0	-30.4	Peak	Horizontal
*	7222.0	35.6	11.8	47.3	78.6	-31.3	Peak	Horizontal
*	7978.5	36.8	12.6	49.4	78.6	-29.2	Peak	Horizontal
	4085.5	38.1	2.7	40.8	74.0	-33.2	Peak	Vertical
	4740.0	37.0	5.4	42.4	74.0	-31.6	Peak	Vertical
*	7069.0	36.2	11.1	47.3	78.6	-31.3	Peak	Vertical
*	8828.5	35.8	13.4	49.2	78.6	-29.4	Peak	Vertical

Note 1: "*" is not in restricted band, its limit is 20dBc of the fundamental emission level (98.6dBμV/m) or FCC 15.209 which is higher.

Note 2: Measure Level (dBμV/m) = Reading Level (dBμV) + Factor (dB)

Factor (dB) = Cable Loss (dB) + Antenna Factor (dB/m) - Pre_Amplifier Gain (dB)

Product	DOLPHIN CT40	Temperature	25°C
Test Engineer	Larry Yan	Relative Humidity	58%
Test Site	AC1	Test Date	2019/09/19
Test Mode:	802.11n-HT40	Test Channel:	09
Remark:	1. Average measurement was not performed if peak level lower than average limit. 2. Other frequency was 20dB below limit line within 1-18GHz, there is not show in the report.		

Mark	Frequency (MHz)	Reading Level (dBμV)	Factor (dB)	Measure Level (dBμV/m)	Limit (dBμV/m)	Margin (dB)	Detector	Polarization
	3881.5	38.1	2.2	40.3	74.0	-33.7	Peak	Horizontal
	5046.0	37.2	6.2	43.5	74.0	-30.5	Peak	Horizontal
*	6499.5	35.9	9.4	45.3	80.3	-35.0	Peak	Horizontal
*	7936.0	36.8	12.6	49.4	80.3	-30.9	Peak	Horizontal
	3992.0	38.9	2.5	41.4	74.0	-32.6	Peak	Vertical
	4697.5	37.6	5.1	42.7	74.0	-31.3	Peak	Vertical
*	6423.0	36.6	8.9	45.5	80.3	-34.8	Peak	Vertical
*	8021.0	36.2	12.6	48.8	80.3	-31.5	Peak	Vertical

Note 1: "*" is not in restricted band, its limit is 20dBc of the fundamental emission level (100.3dBμV/m) or FCC 15.209 which is higher.

Note 2: Measure Level (dBμV/m) = Reading Level (dBμV) + Factor (dB)

Factor (dB) = Cable Loss (dB) + Antenna Factor (dB/m) - Pre_Amplifier Gain (dB)

The Worst Case of Radiated Emission below 1GHz:

Site: AC1	Time: 2019/09/19 - 15:52
Limit: FCC_Part15.209_RSE(3m)	Engineer: Jason Gao
Probe: VULB 9168 _20-2000MHz	Polarity: Horizontal
EUT: DOLPHIN CT40	Power: By Battery
Worst Case Mode: Transmit by 802.11n-HT40 at Channel 2437MHz	

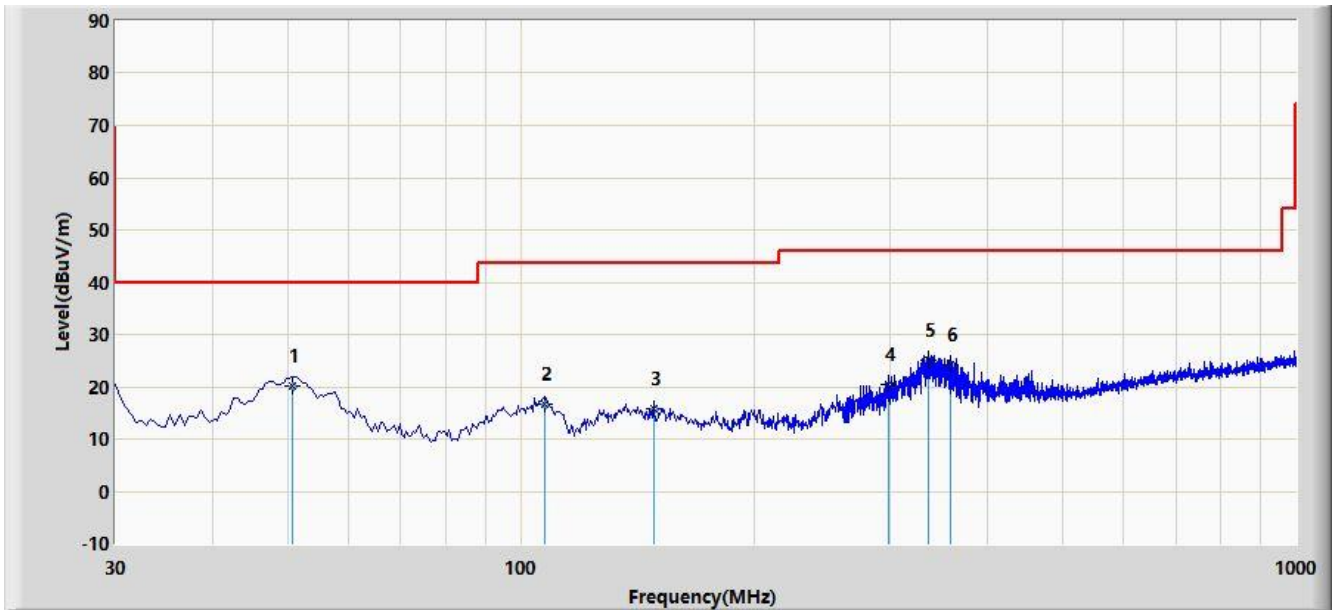

No	Flag	Mark	Frequency (MHz)	Measure Level (dBuV/m)	Reading Level (dBuV)	Margin (dB)	Limit (dBuV/m)	Factor (dB)	Type
1		*	50.855	20.269	6.080	-19.731	40.000	14.189	QP
2			107.600	16.617	4.670	-26.883	43.500	11.947	QP
3			148.340	15.678	0.400	-27.822	43.500	15.279	QP
4			298.690	20.436	5.940	-25.564	46.000	14.496	QP
5			336.035	25.172	9.730	-20.828	46.000	15.442	QP
6			358.345	24.222	8.340	-21.778	46.000	15.881	QP

Note 1: Measure Level (dB μ V/m) = Reading Level (dB μ V) + Factor (dB)

Factor (dB) = Cable Loss (dB) + Antenna Factor (dB/m)

Note 2: The test trace is same as the ambient noise and the amplitude of the emissions are attenuated more than 20dB below the permissible (the test frequency range: 9kHz ~ 30MHz, 18GHz ~ 25GHz), therefore no data appear in the report.

Site: AC1	Time: 2019/09/19 - 15:53
Limit: FCC_Part15.209_RSE(3m)	Engineer: Jason Gao
Probe: VULB 9168 _20-2000MHz	Polarity: Vertical
EUT: DOLPHIN CT40	Power: By Battery
Worst Case Mode: Transmit by 802.11n-HT40 at Channel 2437MHz	

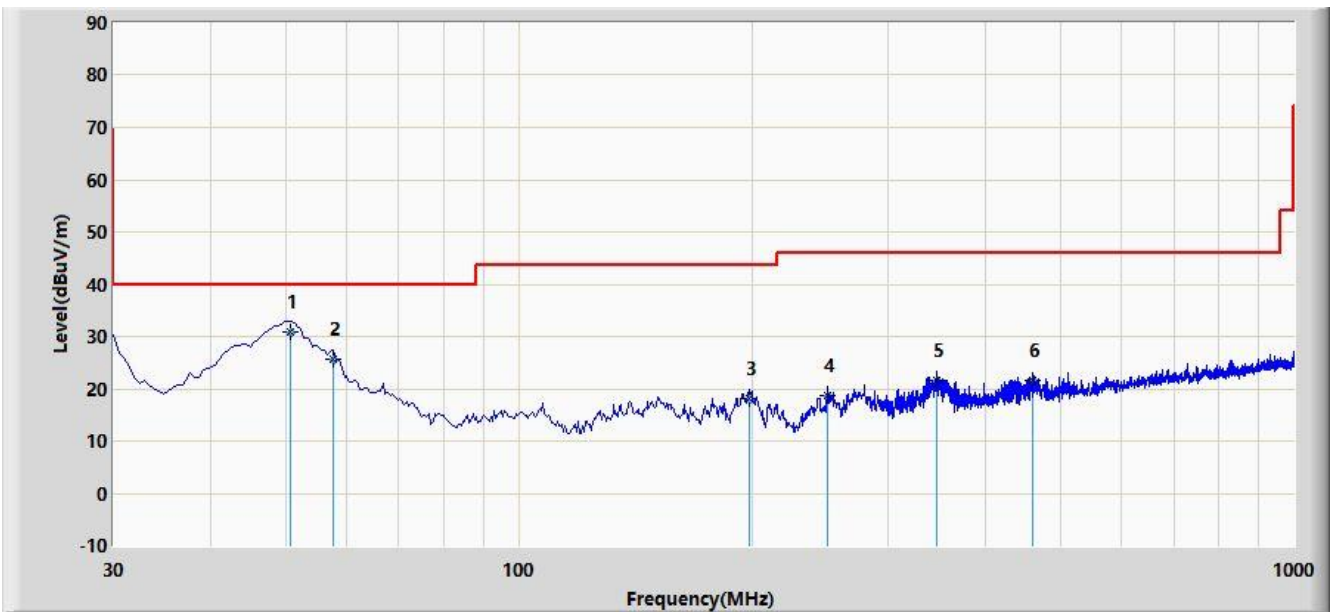

No	Flag	Mark	Frequency (MHz)	Measure Level (dBuV/m)	Reading Level (dBuV)	Margin (dB)	Limit (dBuV/m)	Factor (dB)	Type
1		*	50.855	31.009	16.820	-8.991	40.000	14.189	QP
2			57.645	25.598	11.900	-14.402	40.000	13.698	QP
3			198.780	18.156	6.770	-25.344	43.500	11.386	QP
4			250.675	18.595	5.430	-27.405	46.000	13.166	QP
5			346.705	21.660	6.030	-24.340	46.000	15.630	QP
6			460.680	21.493	3.280	-24.507	46.000	18.213	QP

Note 1: Measure Level (dB μ V/m) = Reading Level (dB μ V) + Factor (dB)

Factor (dB) = Cable Loss (dB) + Antenna Factor (dB/m)

Note 2: The test trace is same as the ambient noise and the amplitude of the emissions are attenuated more than 20dB below the permissible (the test frequency range: 9kHz ~ 30MHz, 18GHz ~ 25GHz), therefore no data appear in the report.

7.7. Radiated Restricted Band Edge Measurement

7.7.1. Test Limit

For 15.205 requirement:

Radiated emissions which fall in the restricted bands, as defined in Section 15.205(a) of FCC part 15, must also comply with the radiated emission limits specified in Section 15.209(a).

Frequency (MHz)	Frequency (MHz)	Frequency (MHz)	Frequency (GHz)
0.090 - 0.110	16.42 - 16.423	399.9 - 410	4.5 - 5.15
¹ 0.495 - 0.505	16.69475 - 16.69525	608 - 614	5.35 - 5.46
2.1735 - 2.1905	16.80425 - 16.80475	960 - 1240	7.25 - 7.75
4.125 - 4.128	25.5 - 25.67	1300 - 1427	8.25 - 8.5
4.17725 - 4.17775	37.5 - 38.25	1435 - 1626.5	9.0 - 9.2
4.20725 - 4.20775	73 - 74.6	1645.5 - 1646.5	9.3 - 9.5
6.215 - 6.218	74.8 - 75.2	1660 - 1710	10.6 - 12.7
6.26775 - 6.26825	108 - 121.94	1718.8 - 1722.2	13.25 - 13.4
6.31175 - 6.31225	123 - 138	2200 - 2300	14.47 - 14.5
8.291 - 8.294	149.9 - 150.05	2310 - 2390	15.35 - 16.2
8.362 - 8.366	156.52475 - 156.525	2483.5 - 2500	17.7 - 21.4
8.37625 - 8.38675	156.7 - 156.9	2690 - 2900	22.01 - 23.12
8.41425 - 8.41475	162.0125 - 167.17	3260 - 3267	23.6 - 24.0
12.29 - 12.293	167.72 - 173.2	3332 - 3339	31.2 - 31.8
12.51975 - 12.52025	240 - 285	3345.8 - 3358	36.43 - 36.5
12.57675 - 12.57725	322 - 335.4	3600 - 4400	(²)
13.36 - 13.41	--	--	--

All out of band emissions appearing in a restricted band as specified in Section 15.205 of the Title 47CFR must not exceed the limits shown in Table per Section 15.209.

FCC Part 15 Subpart C Paragraph 15.209		
Frequency [MHz]	Field Strength [uV/m]	Measured Distance [Meters]
0.009 - 0.490	2400/F (kHz)	300
0.490 - 1.705	24000/F (kHz)	30
1.705 - 30	30	30
30 - 88	100	3
88 - 216	150	3
216 - 960	200	3
Above 960	500	3

For RSS-Gen Section 8.10 requirement:

Radiated emissions which fall in the restricted bands, as defined in Section 8.10 of RSS-Gen, must also comply with the radiated emission limits specified in Section 8.9.

Frequency (MHz)	Frequency (MHz)	Frequency (GHz)
0.009 - 0.110	149.9 - 150.05	9.0 - 9.2
0.495 - 0.505	156.52475 - 156.525225	9.3 - 9.5
2.1735 - 2.1905	156.7 - 156.9	10.6 - 12.7
3.020 - 3.026	162.0125 - 167.17	13.25 - 13.4
4.125 - 4.128	167.72 - 173.2	14.47 - 14.5
4.17725 - 4.17775	240 - 285	15.35 - 16.2
4.20725 - 4.20775	322 - 335.4	17.7 - 21.4
5.677 - 5.683	399.9 - 410	22.01 - 23.12
6.215 - 6.218	608 - 614	23.6 - 24.0
6.26775 - 6.26825	960 - 1427	31.2 - 31.8
6.31175 - 6.31225	1435 - 1626.5	36.43 - 36.5
8.291 - 8.294	1645.5 - 1646.5	Above 38.6
8.362 - 8.366	1660 - 1710	--
8.37625 - 8.38675	1718.8 - 1722.2	--
8.41425 - 8.41475	2200 - 2300	--
12.29 - 12.293	2310 - 2390	--
12.51975 - 12.52025	2483.5 - 2500	--
12.57675 - 12.57725	2655 - 2900	--
13.36 - 13.41	3260 - 3267	--
16.42 - 16.423	3332 - 3339	--
16.69475 - 16.69525	3345.8 - 3358	--
16.80425 - 16.80475	3500 - 4400	--
25.5 - 25.67	4500 - 5150	--
37.5 - 38.25	5350 - 5460	--
73 - 74.6	7250 - 7750	--
74.8 - 75.2	8025 - 8500	--
108 - 138	--	--

All out of band emissions appearing in a restricted band as specified in Section 8.10 of the RSS-Gen must not exceed the limits shown in Table per Section 8.9.

RSS-Gen Section 8.9		
Frequency [MHz]	Field Strength [uV/m]	Measured Distance [Meters]
0.009 - 0.490	2400/F (kHz)	300
0.490 - 1.705	24000/F (kHz)	30
1.705 - 30	30	30
30 - 88	100	3
88 - 216	150	3
216 - 960	200	3
Above 960	500	3

7.7.2. Test Procedure Used

ANSI C63.10 Section 6.3 (General Requirements)

ANSI C63.10 Section 6.6 (Standard test method above 1GHz)

7.7.3. Test Setting

Peak Field Strength Measurements

1. Analyzer center frequency was set to the frequency of the radiated spurious emission of interest
2. RBW = 1MHz
3. VBW = 3MHz
4. Detector = peak
5. Sweep time = auto couple
6. Trace mode = max hold
7. Trace was allowed to stabilize

Average Field Strength Measurements

1. Analyzer center frequency was set to the frequency of the radiated spurious emission of interest
2. RBW = 1MHz
3. VBW $\geq 1/T$
4. De As an alternative, the instrument may be set to linear detector mode. Ensure that video filtering is applied in linear voltage domain (rather than in a log or dB domain). Some instruments require linear display mode in order to accomplish this. Others have a setting for Average-VBW Type, which can be set to "Voltage" regardless of the display mode
5. Detector = Peak
6. Sweep time = auto
7. Trace mode = max hold
8. Allow max hold to run for at least 50 times (1/duty cycle) traces

7.7.4. Test Setup

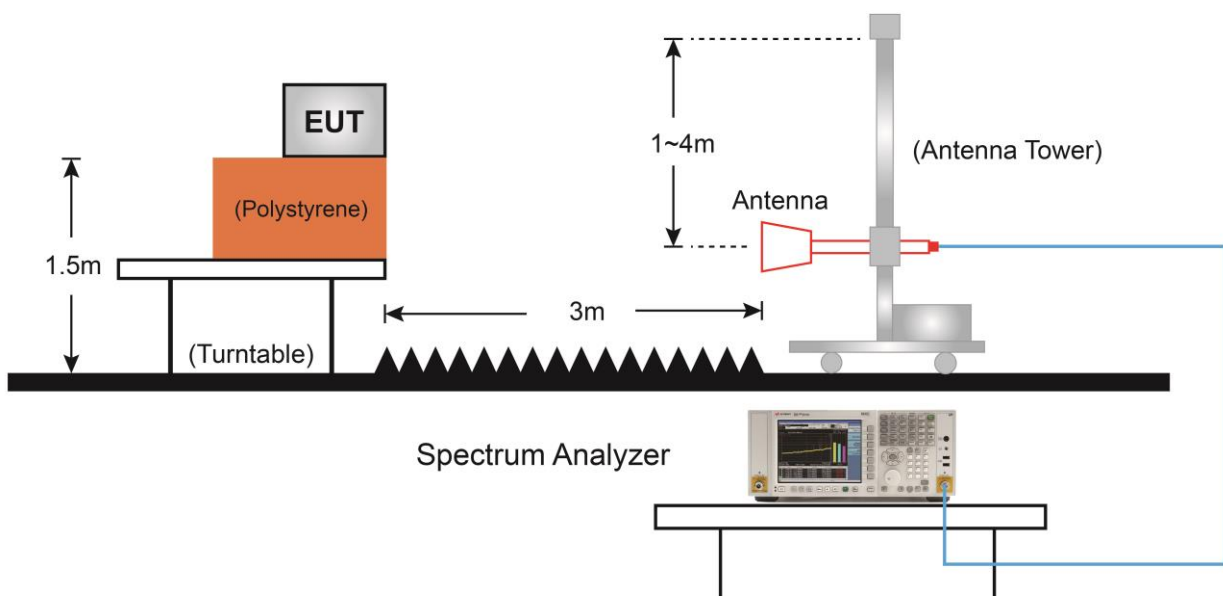

7.7.5. Test Result

Site: AC1	Time: 2019/09/18 - 18:38
Limit: FCC_Part15.209_RE(3m)	Engineer: Larry Yan
Probe: BBHA9120D_1-18GHz	Polarity: Horizontal
EUT: DOLPHIN CT40	Power: By Battery
Test Mode: Transmit by 802.11n-HT40 at Channel 2422MHz	

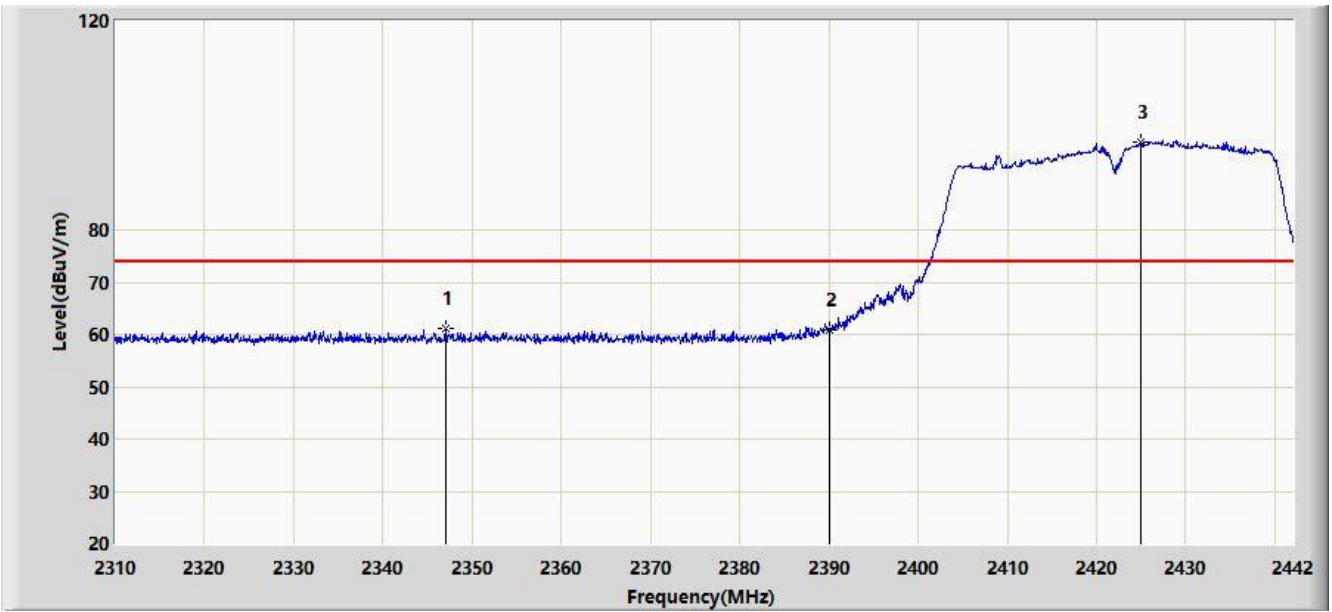

No	Flag	Mark	Frequency (MHz)	Measure Level (dBuV/m)	Reading Level (dBuV)	Margin (dB)	Limit (dBuV/m)	Factor (dB)	Type
1			2347.026	61.198	28.674	-12.802	74.000	32.524	PK
2			2390.000	60.898	28.485	-13.102	74.000	32.413	PK
3		*	2425.038	96.946	64.577	N/A	N/A	32.369	PK

Note: Measure Level (dB μ V/m) = Reading Level (dB μ V) + Factor (dB)

Factor (dB) = Cable Loss (dB) + Antenna Factor (dB/m)

Site: AC1	Time: 2019/09/18 - 18:41
Limit: FCC_Part15.209_RE(3m)	Engineer: Larry Yan
Probe: BBHA9120D_1-18GHz	Polarity: Horizontal
EUT: DOLPHIN CT40	Power: By Battery
Test Mode: Transmit by 802.11n-HT40 at Channel 2422MHz	

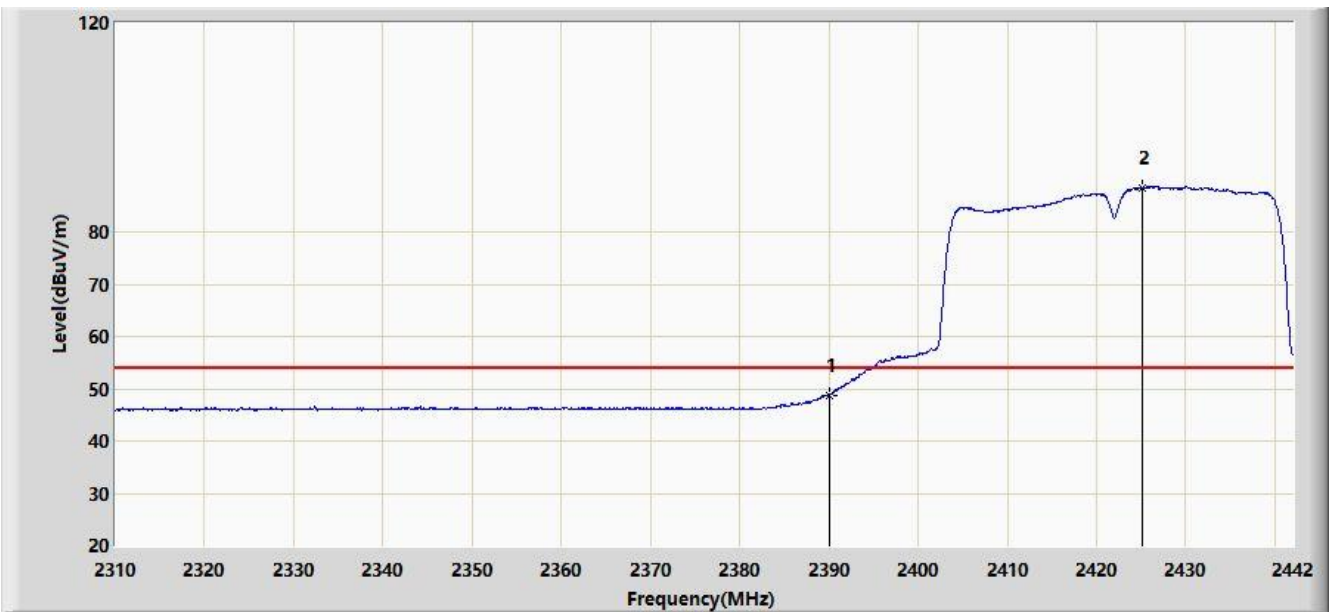

No	Flag	Mark	Frequency (MHz)	Measure Level (dBuV/m)	Reading Level (dBuV)	Margin (dB)	Limit (dBuV/m)	Factor (dB)	Type
1			2390.000	48.687	16.274	-5.313	54.000	32.413	AV
2		*	2425.104	88.494	56.125	N/A	N/A	32.369	AV

Note: Measure Level (dB μ V/m) = Reading Level (dB μ V) + Factor (dB)

Factor (dB) = Cable Loss (dB) + Antenna Factor (dB/m)

Site: AC1	Time: 2019/09/18 - 18:44
Limit: FCC_Part15.209_RE(3m)	Engineer: Larry Yan
Probe: BBHA9120D_1-18GHz	Polarity: Vertical
EUT: DOLPHIN CT40	Power: By Battery
Test Mode: Transmit by 802.11n-HT40 at Channel 2422MHz	

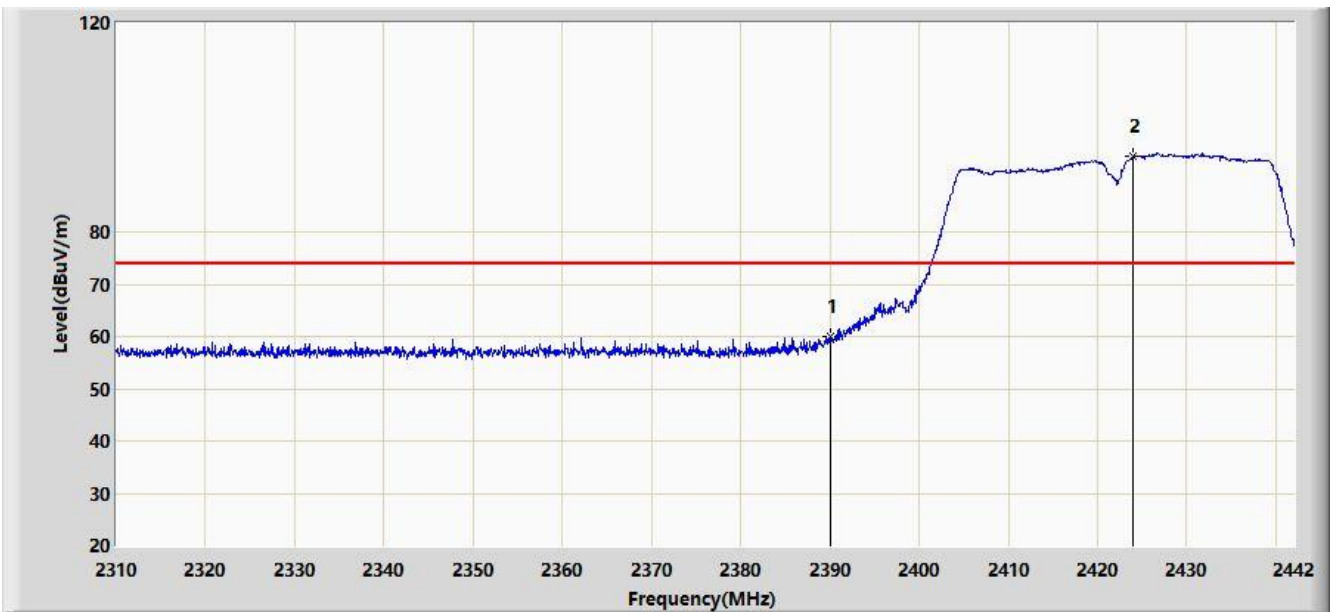

No	Flag	Mark	Frequency (MHz)	Measure Level (dBuV/m)	Reading Level (dBuV)	Margin (dB)	Limit (dBuV/m)	Factor (dB)	Type
1			2390.000	59.904	27.491	-14.096	74.000	32.413	PK
2		*	2424.048	94.493	62.123	N/A	N/A	32.370	PK

Note: Measure Level (dB μ V/m) = Reading Level (dB μ V) + Factor (dB)

Factor (dB) = Cable Loss (dB) + Antenna Factor (dB/m)

Site: AC1	Time: 2019/09/18 - 18:47
Limit: FCC_Part15.209_RE(3m)	Engineer: Larry Yan
Probe: BBHA9120D_1-18GHz	Polarity: Vertical
EUT: DOLPHIN CT40	Power: By Battery
Test Mode: Transmit by 802.11n-HT40 at Channel 2422MHz	

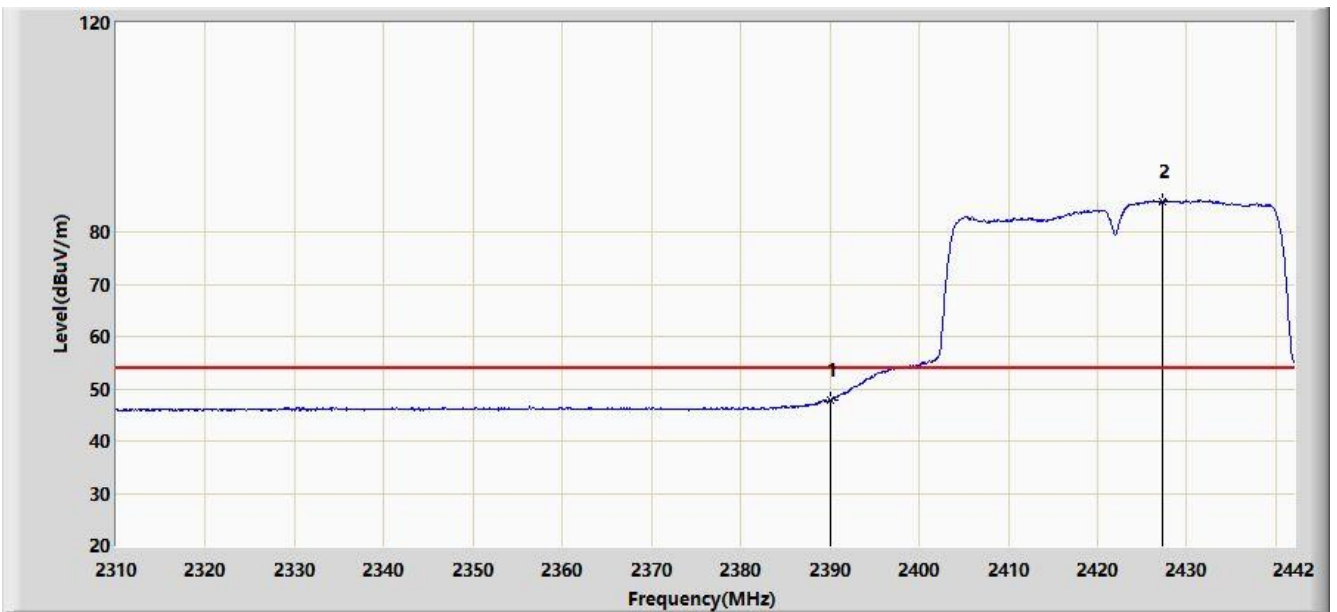

No	Flag	Mark	Frequency (MHz)	Measure Level (dBuV/m)	Reading Level (dBuV)	Margin (dB)	Limit (dBuV/m)	Factor (dB)	Type
1			2390.000	47.684	15.271	-6.316	54.000	32.413	AV
2		*	2427.348	85.759	53.392	N/A	N/A	32.366	AV

Note: Measure Level (dB μ V/m) = Reading Level (dB μ V) + Factor (dB)

Factor (dB) = Cable Loss (dB) + Antenna Factor (dB/m)

Site: AC1	Time: 2019/09/19 - 02:07
Limit: FCC_Part15.209_RE(3m)	Engineer: Larry Yan
Probe: BBHA9120D_1-18GHz	Polarity: Horizontal
EUT: DOLPHIN CT40	Power: By Battery
Test Mode: Transmit by 802.11n-HT40 at Channel 2452MHz	



No	Flag	Mark	Frequency (MHz)	Measure Level (dBuV/m)	Reading Level (dBuV)	Margin (dB)	Limit (dBuV/m)	Factor (dB)	Type
1		*	2435.026	100.290	67.936	N/A	N/A	32.354	PK
2			2483.500	62.493	30.078	-11.507	74.000	32.416	PK
3			2484.360	64.116	31.699	-9.884	74.000	32.417	PK

Note: Measure Level (dB μ V/m) = Reading Level (dB μ V) + Factor (dB)

Factor (dB) = Cable Loss (dB) + Antenna Factor (dB/m)

Site: AC1	Time: 2019/09/19 - 02:11
Limit: FCC_Part15.209_RE(3m)	Engineer: Larry Yan
Probe: BBHA9120D_1-18GHz	Polarity: Horizontal
EUT: DOLPHIN CT40	Power: By Battery
Test Mode: Transmit by 802.11n-HT40 at Channel 2452MHz	

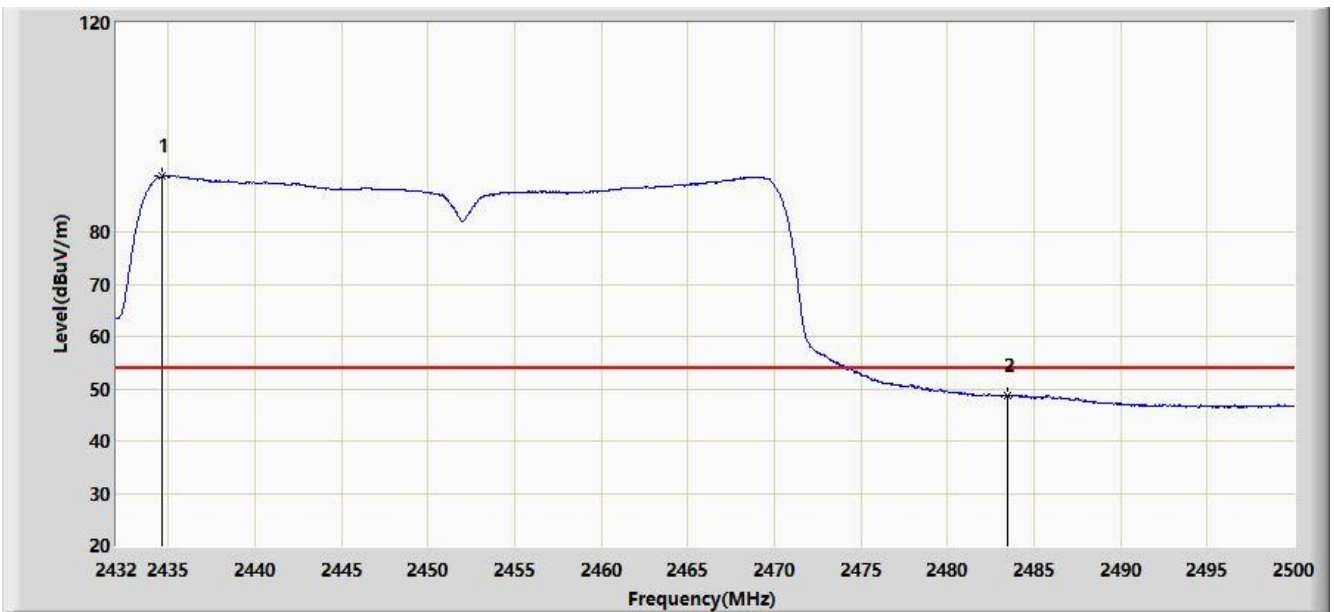

No	Flag	Mark	Frequency (MHz)	Measure Level (dBuV/m)	Reading Level (dBuV)	Margin (dB)	Limit (dBuV/m)	Factor (dB)	Type
1		*	2434.652	90.664	58.309	N/A	N/A	32.355	AV
2			2483.500	48.718	16.303	-5.282	54.000	32.416	AV

Note: Measure Level (dBμV/m) = Reading Level (dBμV) + Factor (dB)

Factor (dB) = Cable Loss (dB) + Antenna Factor (dB/m)

Site: AC1	Time: 2019/09/19 - 02:12
Limit: FCC_Part15.209_RE(3m)	Engineer: Larry Yan
Probe: BBHA9120D_1-18GHz	Polarity: Vertical
EUT: DOLPHIN CT40	Power: By Battery
Test Mode: Transmit by 802.11n-HT40 at Channel 2452MHz	

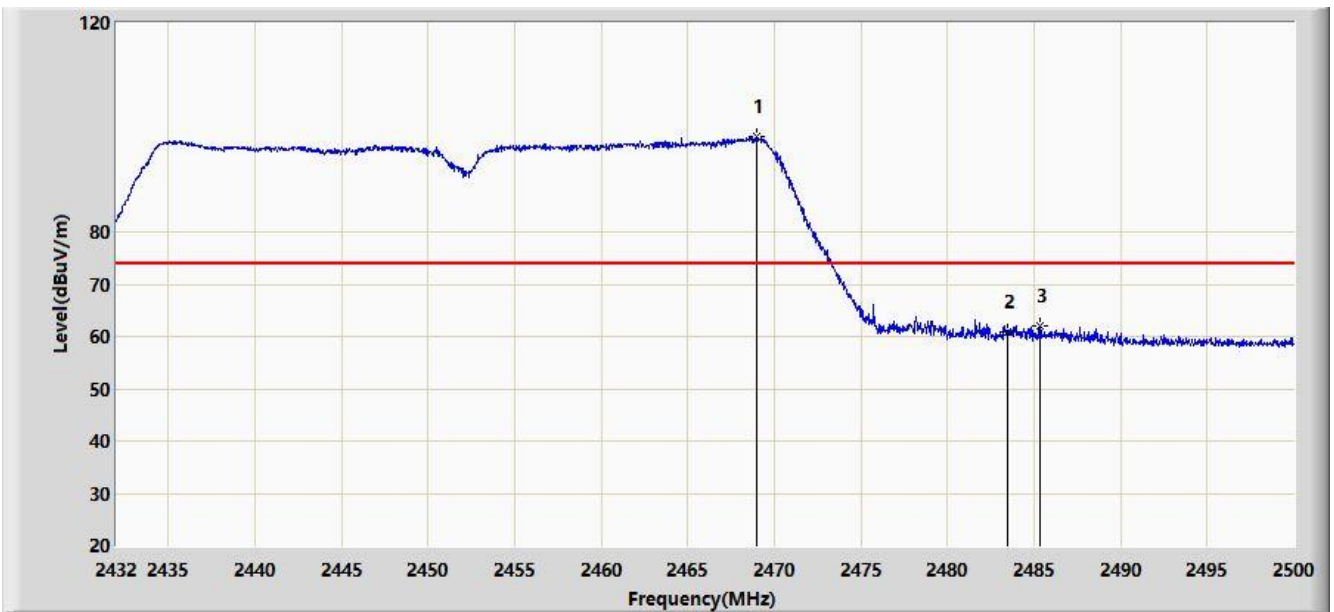

No	Flag	Mark	Frequency (MHz)	Measure Level (dBuV/m)	Reading Level (dBuV)	Margin (dB)	Limit (dBuV/m)	Factor (dB)	Type
1		*	2468.958	98.167	65.785	N/A	N/A	32.382	PK
2			2483.500	60.780	28.365	-13.220	74.000	32.416	PK
3			2485.346	62.169	29.750	-11.831	74.000	32.419	PK

Note: Measure Level (dB μ V/m) = Reading Level (dB μ V) + Factor (dB)

Factor (dB) = Cable Loss (dB) + Antenna Factor (dB/m)

Site: AC1	Time: 2019/09/19 - 02:14
Limit: FCC_Part15.209_RE(3m)	Engineer: Larry Yan
Probe: BBHA9120D_1-18GHz	Polarity: Vertical
EUT: DOLPHIN CT40	Power: By Battery
Test Mode: Transmit by 802.11n-HT40 at Channel 2452MHz	

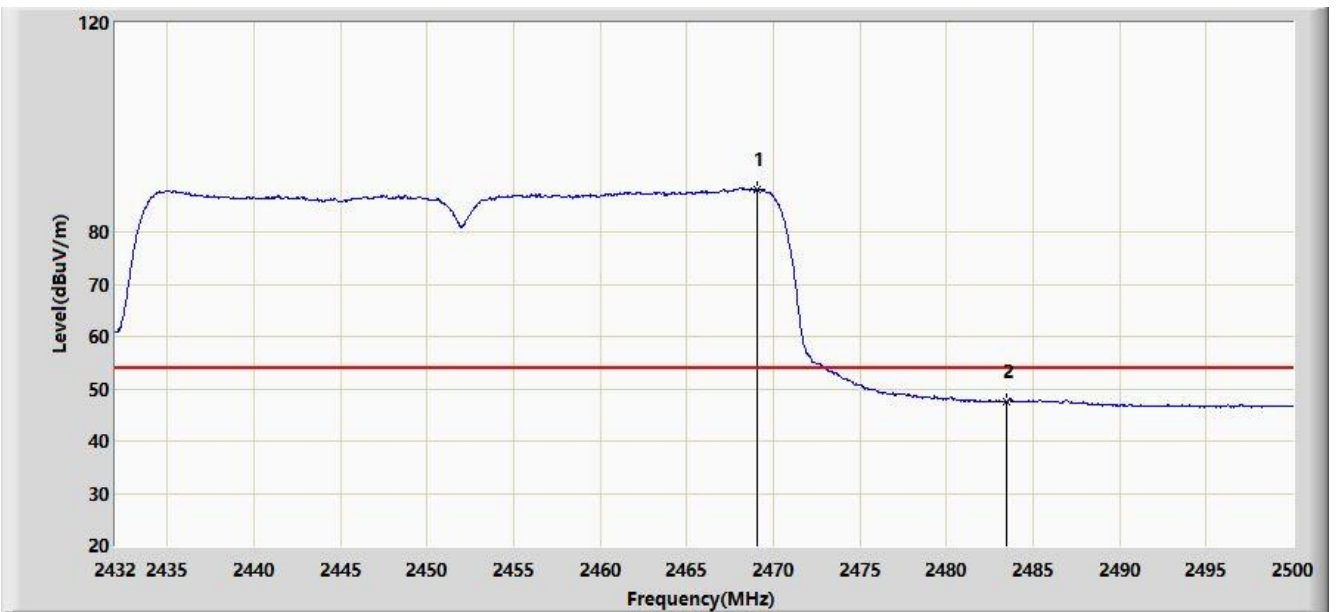

No	Flag	Mark	Frequency (MHz)	Measure Level (dBuV/m)	Reading Level (dBuV)	Margin (dB)	Limit (dBuV/m)	Factor (dB)	Type
1		*	2469.094	88.210	55.828	N/A	N/A	32.383	AV
2			2483.500	47.470	15.055	-6.530	54.000	32.416	AV

Note: Measure Level (dBuV/m) = Reading Level (dBuV) + Factor (dB)

Factor (dB) = Cable Loss (dB) + Antenna Factor (dB/m)

7.8. AC Conducted Emissions Measurement

7.8.1. Test Limit

FCC Part 15 Subpart C Paragraph 15.207 Limits		
Frequency (MHz)	QP (dBuV)	AV (dBuV)
0.15 - 0.50	66 - 56	56 - 46
0.50 - 5.0	56	46
5.0 - 30	60	50

Note 1: The lower limit shall apply at the transition frequencies.

Note 2: The limit decreases linearly with the logarithm of the frequency in the range 0.15MHz to 0.5MHz.

7.8.2. Test Setup

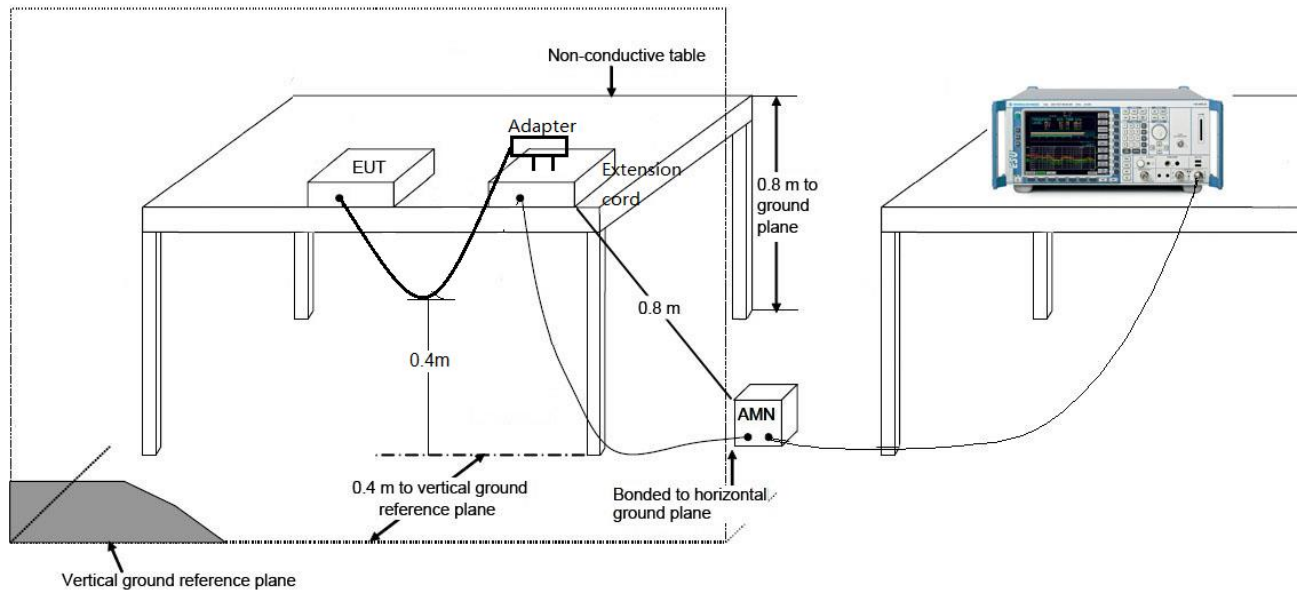

7.8.3. Test Result

Site: SR2	Time: 2019/09/22 - 11:16
Limit: FCC_Part15.207_CE_AC Power	Engineer: Bacon Dong
Probe: ENV216_101683_Filter On	Polarity: Line
EUT: DOLPHIN CT40	Power: AC 120V/60Hz
Test Mode: Mode 1	

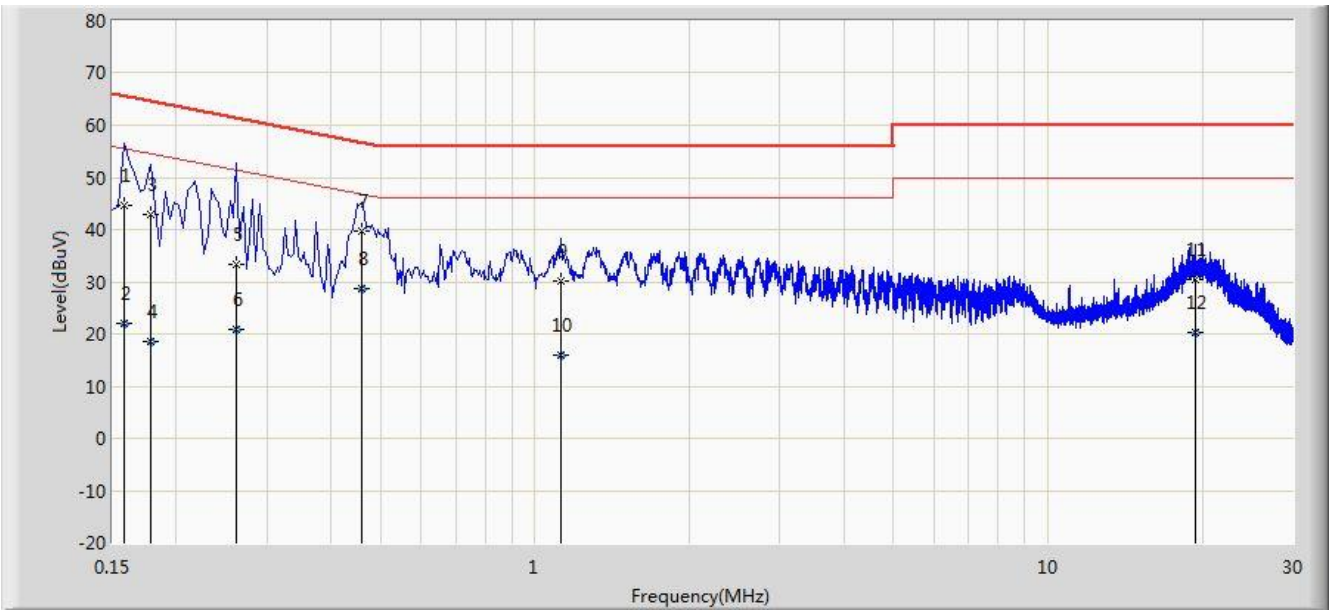

No	Flag	Mark	Frequency (MHz)	Measure Level (dBuV)	Reading Level (dBuV)	Margin (dB)	Limit (dBuV)	Factor (dB)	Type
1			0.158	44.547	34.236	-21.022	65.568	10.311	QP
2			0.158	21.942	11.631	-33.627	55.568	10.311	AV
3			0.178	42.757	32.699	-21.821	64.578	10.058	QP
4			0.178	18.625	8.567	-35.953	54.578	10.058	AV
5			0.262	33.319	23.345	-28.049	61.368	9.974	QP
6			0.262	20.929	10.955	-30.439	51.368	9.974	AV
7		*	0.458	39.792	29.660	-16.937	56.729	10.133	QP
8			0.458	28.556	18.423	-18.173	46.729	10.133	AV
9			1.126	30.261	20.357	-25.739	56.000	9.904	QP
10			1.126	15.915	6.011	-30.085	46.000	9.904	AV
11			19.426	30.509	20.380	-29.491	60.000	10.129	QP
12			19.426	20.184	10.055	-29.816	50.000	10.129	AV

Note: Measure Level (dBμV) = Reading Level (dBμV) + Factor (dB)

Factor (dB) = Cable Loss (dB) + LISN Factor (dB)

Site: SR2	Time: 2019/09/22 - 11:20
Limit: FCC_Part15.207_CE_AC Power	Engineer: Bacon Dong
Probe: ENV216_101683_Filter On	Polarity: Neutral
EUT: DOLPHIN CT40	Power: AC 120V/60Hz
Test Mode: Mode 1	

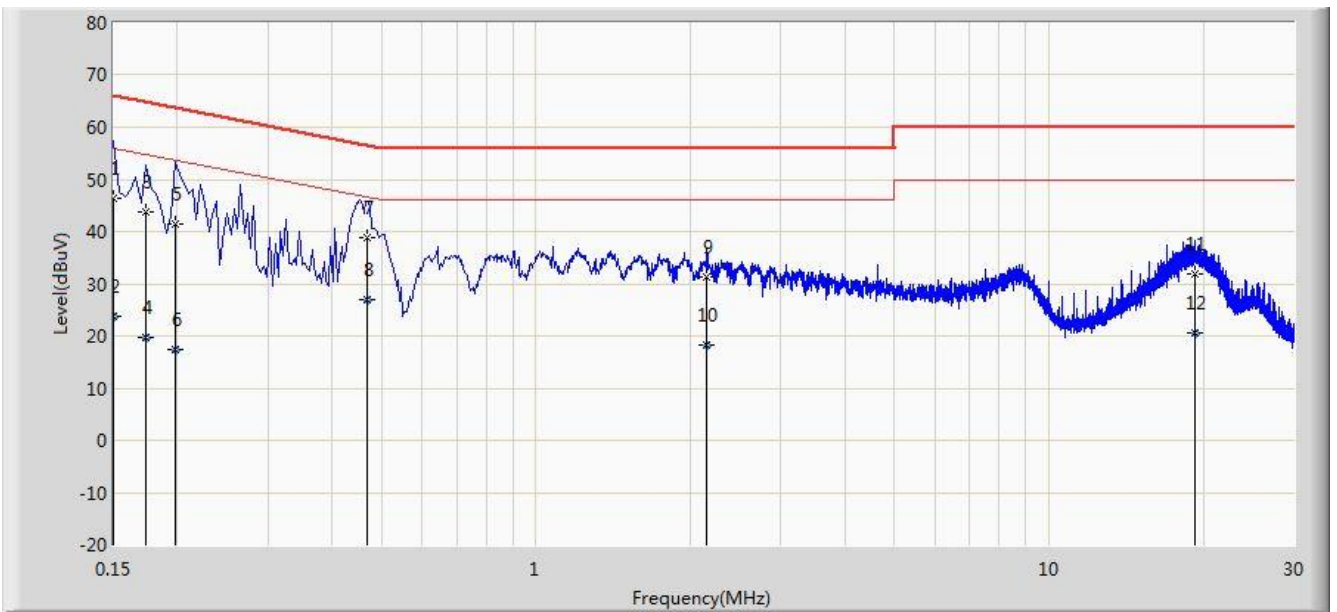

No	Flag	Mark	Frequency (MHz)	Measure Level (dBuV)	Reading Level (dBuV)	Margin (dB)	Limit (dBuV)	Factor (dB)	Type
1			0.150	46.470	35.328	-19.530	66.000	11.142	QP
2			0.150	23.829	12.687	-32.171	56.000	11.142	AV
3			0.174	43.730	33.673	-21.038	64.767	10.057	QP
4			0.174	19.827	9.771	-34.940	54.767	10.057	AV
5			0.198	41.558	31.543	-22.136	63.694	10.015	QP
6			0.198	17.287	7.272	-36.407	53.694	10.015	AV
7		*	0.470	38.937	28.772	-17.577	56.514	10.164	QP
8			0.470	27.087	16.923	-19.426	46.514	10.164	AV
9			2.154	31.174	21.305	-24.826	56.000	9.870	QP
10			2.154	18.237	8.367	-27.763	46.000	9.870	AV
11			19.190	31.749	21.586	-28.251	60.000	10.163	QP
12			19.190	20.459	10.296	-29.541	50.000	10.163	AV

Note: Measure Level (dBμV) = Reading Level (dBμV) + Factor (dB)

Factor (dB) = Cable Loss (dB) + LISN Factor (dB)

8. CONCLUSION

The data collected relate only the item(s) tested and show that the **DOLPHIN CT40** is in compliance with Part 15C of the FCC rules and ISED rules.

————— The End —————

Appendix A - Test Setup Photograph

Refer to “1909RSU018-UT” file.

Appendix B - EUT Photograph

Refer to "1909RSU018-UE" file.