

TEST REPORT

Report No.: 25030088HKG-002

VTech Telecommunications Ltd.

Application for Original Grant of 47 CFR Part 15 Certification

Single New of RSS-247 Issue 3 Certification

Wired Thermostat

This report contains the data of 5GHz WLAN (Wi-Fi) portion only.

FCC ID: EW780-T132-00

IC: 1135B-80T13200

Prepared and Checked by:

Approved by:

Signed on File

Leung Chun Ning, Peter
Engineer

Wong Cheuk Ho, Herbert
Assistant Manager

Date: June 03, 2025

Intertek's standard Terms and Conditions can be obtained at our website <http://www.intertek.com/terms/>.

The test report only allows to be revised within the retention period unless further standard or the requirement was noticed.

This report is for the exclusive use of Intertek's Client and is provided pursuant to the agreement between Intertek and its Client. Intertek's responsibility and liability are limited to the terms and conditions of the agreement. Intertek assumes no liability to any party, other than to the Client in accordance with the agreement, for any loss, expense or damage occasioned by the use of this report. Only the Client is authorized to permit copying or distribution of this report and then only in its entirety. Any use of the Intertek name or one of its marks for the sale or advertisement of the tested material, product or service must first be approved in writing by Intertek. The observations and test results in this report are relevant only to the sample tested. This report by itself does not imply that the material, product, or service is or has ever been under an Intertek certification program.

© 2017 Intertek

TEST REPORT

GENERAL INFORMATION

Grantee:	VTech Telecommunications Ltd.
Grantee Address:	23/F., Tai Ping Industrial Centre, Block 1, 57 Ting Kok Road, Tai Po, Hong Kong.
Manufacturer Name:	VTech (Dongguan) Telecommunications Limited
Manufacturer Address:	VTech Science Park, Xia Ling Bei Management Zone, Liaobu, Dongguan, Guangdong, China.
FCC Specification Standard:	FCC Part 15, October 1, 2023 Edition
FCC ID:	EW780-T132-00
FCC Model(s):	ST962WN50
IC Specification Standard:	RSS-247 Issue 3, August 2023 RSS-Gen Issue 5 Amendment 2, February 2021
IC:	1135B-80T13200
HVIN:	35-400623
PMN:	ST962WN50
Type of EUT:	Unlicensed National Information Infrastructure Transmitter
Description of EUT:	Wired Thermostat
Brand Name:	Seasons
Sample Receipt Date:	April 03, 2025
Date of Test:	April 03, 2025 to May 23, 2025
Report Date:	June 03, 2025
Environmental Conditions:	Temperature: +10 to 40°C Relative Humidity: 10 to 90%
Conclusion:	Test was conducted by client submitted sample. The submitted sample as received complied with the 47 CFR Part 15 / RSS-247 Issue 3 Certification.
Remark:	This report contains the data of 5GHz Wi-Fi portion only

TEST REPORT

SUMMARY OF TEST RESULT

Test Items	FCC Part 15 Section	RSS-247 / RSS-Gen# Section	Results
Antenna Requirement	15.407(a)	6.2.1.1/ 6.2.3.1/ 6.2.4.1	Complied
Max. Conducted Output Power (Peak)	15.407(a)	6.2.1.1/ 6.2.3.1/ 6.2.4.1	Complied
Transmit Power Control (TPC)	15.407(h)		Not Applicable
Min. 6dB RF Bandwidth	15.407(e)	6.2.4.1	Complied
26 dB emission bandwidth	15.407(a)		Complied
Occupied Bandwidth	N/A		Complied
Max. Power Density (Average)	15.407(a)	6.2.4.1	Complied
Out of Band Antenna Conducted Emission	15.407(b)	6.2.4.2	Not Applicable
Radiated Emission in Restricted Bands and Spurious Emissions	15.407(b), 15.209 & 15.109	6.2.4.2	Complied
AC Power Line Conducted Emission	15.207 & 15.107	7.2.4#	Complied
Dynamic Frequency Selection (DFS)	15.407		Complied

Remark: Not Applicable (If the EUT is <500mW (27dBm))

Note: Pursuant to FCC Part 15 Section 15.215(c), the 20dB bandwidth of the emission was contained within the frequency band designated (mentioned as above) which the EUT operated. The effects, if any, from frequency sweeping, frequency hopping, other modulation techniques and frequency stability over expected variations in temperature and supply voltage were considered.

For all technical data, which can be referred to Annex B – Report cover sheet.

For electronic filing, the Annex B – Report cover sheet is saved with filename: Annex B.pdf.

The equipment under test is found to be complying with the following standards:

FCC Part 15, October 1, 2023 Edition

RSS-247 Issue 3, August 2023

RSS-Gen Issue 5 Amendment 2, February 2021

TEST REPORT

TABLE OF CONTENTS

EXHIBIT 1	GENERAL DESCRIPTION	5
1.1	Product Description	5
1.2	Test Methodology	6
1.4	Test Facility.....	6
1.5	Related Submittal(s) Grants.....	6
EXHIBIT 2	SYSTEM TEST CONFIGURATION	7
2.1	Justification	7
2.2	EUT Exercising Software.....	8
2.3	Description of Accessories	8
2.4	Measurement Uncertainty.....	8
EXHIBIT 3	TEST RESULTS.....	9
3.1	Maximum Conducted (Peak) Output Power at Antenna Terminals.....	9
3.3	Minimum 6dB RF Bandwidth	12
3.3	26dB Bandwidth and Occupied Bandwidth	13
3.4	Maximum Power Spectral Density.....	15
3.6	Field Strength Calculation	18
3.7	Transmitter Radiated Emissions in Restricted Bands and Spurious Emissions	19
4.7	AC Power Line Conducted Emission	39
3.8	Frequency Stability Requirement	41
3.9	U-NII-1 99% Bandwidth Requirement	41
3.8	Dynamic Frequency Selection (DFS)	42
EXHIBIT 4	EQUIPMENT LIST	51

TEST REPORT

EXHIBIT 1 GENERAL DESCRIPTION

1.1 Product Description

The ST962WN50 (35-400623) is a Thermostat.

For 5.15GHz to 5.25GHz Band:

The module operates at Frequency range of 5.18GHz to 5.24GHz.

For IEEE 802.11a mode, it operates at frequency range of 5.18GHz to 5.24GHz with 4 channels. It transmits via OFDM/64-QAM, 16-QAM, QPSK and BPSK modulation. Maximum bit rate can be up to 54Mbps.

For IEEE 802.11n (with 20 MHz Bandwidth) mode, it operates at frequency range of 5.18GHz to 5.24GHz with 4 channels. It transmits via OFDM/64-QAM, 16-QAM, QPSK and BPSK modulation. Maximum bit rate can support up to MCS7 65Mbps.

For IEEE 802.11n (with 40 MHz Bandwidth) mode, it operates at frequency range of 5.19GHz to 5.23GHz with 2 channels. It transmits via OFDM/64-QAM, 16-QAM, QPSK and BPSK modulation. Maximum bit rate can support up to MCS7 135Mbps.

For 5.25GHz to 5.35GHz Band:

The module operates at Frequency range of 5.26GHz to 5.32GHz.

For IEEE 802.11a mode, it operates at frequency range of 5.26GHz to 5.32GHz with 4 channels. It transmits via OFDM/64-QAM, 16-QAM, QPSK and BPSK modulation. Maximum bit rate can be up to 54Mbps.

For IEEE 802.11n (with 20 MHz Bandwidth) mode, it operates at frequency range of 5.26GHz to 5.32GHz with 4 channels. It transmits via OFDM/64-QAM, 16-QAM, QPSK and BPSK modulation. Maximum bit rate can support up to MCS7 65Mbps.

For IEEE 802.11n (with 40 MHz Bandwidth) mode, it operates at frequency range of 5.27GHz to 5.32GHz with 2 channels. It transmits via OFDM/64-QAM, 16-QAM, QPSK and BPSK modulation. Maximum bit rate can support up to MCS7 135Mbps.

For 5.47GHz to 5.725GHz Band:

The module operates at Frequency range of 5.5GHz to 5.7GHz.

For IEEE 802.11a mode, it operates at frequency range of 5.5GHz to 5.7GHz with 11 channels. It transmits via OFDM/64-QAM, 16-QAM, QPSK and BPSK modulation. Maximum bit rate can be up to 54Mbps.

For IEEE 802.11n (with 20 MHz Bandwidth) mode, it operates at frequency range of 5.5GHz to 5.7GHz with 11 channels. It transmits via OFDM/64-QAM, 16-QAM, QPSK and BPSK modulation. Maximum bit rate can support up to MCS7 65Mbps.

For IEEE 802.11n (with 40 MHz Bandwidth) mode, it operates at frequency range of 5.51GHz to 5.67GHz with 5 channels. It transmits via OFDM/64-QAM, 16-QAM, QPSK and BPSK modulation. Maximum bit rate can support up to MCS7 135Mbps.

TEST REPORT

1.1 Product Description (Cont'd)

For 5.725GHz to 5.85GHz Band:

The module operates at Frequency range of 5.745GHz to 5.825GHz.

For IEEE 802.11a mode, it operates at frequency range of 5.745GHz to 5.825GHz with 5 channels. It transmits via OFDM/64-QAM, 16-QAM, QPSK and BPSK modulation. Maximum bit rate can be up to 54Mbps.

For IEEE 802.11n (with 20 MHz Bandwidth) mode, it operates at frequency range of 5.745GHz to 5.825GHz with 5 channels. It transmits via OFDM/64-QAM, 16-QAM, QPSK and BPSK modulation. Maximum bit rate can support up to MCS7 65Mbps.

For IEEE 802.11n (with 40 MHz Bandwidth) mode, it operates at frequency range of 5.755GHz to 5.795GHz with 2 channels. It transmits via OFDM/64-QAM, 16-QAM, QPSK and BPSK modulation. Maximum bit rate can support up to MCS7 135Mbps.

Antenna Information:

- PCB Antenna
- WLAN IEEE 802.11 a/b/g/n
- For operating frequency of 2.4GHz , antenna has maximum gain of 0 dBi
- For operating frequency of 5GHz , antenna has maximum gain of 0 dBi

The EUT is powered by 24VAC.

The antenna(s) used in the EUT is integral, and the test sample is a prototype.

The circuit description is saved with filename: descri.pdf.

1.2 Test Methodology

Both AC power line-conducted and radiated emission measurements were performed according to the procedures in ANSI C63.10 (2013). Preliminary radiated scans and all radiated measurements were performed in radiated emission test sites. All Radiated tests were performed at an antenna to EUT distance of 3 meters, unless stated otherwise in the "**Justification Section**" of this Application.

Antenna port conducted measurements were performed according to ANSI C63.10 (2013) and KDB Publication No. 558074 D01 v05r02 (April 02, 2019) All other measurements were made in accordance with the procedures in 47 CFR Part 2 and RSS-Gen Issue 5 Amendment 2, February 2021.

1.3 Test Facility

The radiated emission test site and antenna port conducted measurement facility used to collect the radiated data and conductive data are at Workshop No. 3, G/F., World-Wide Industrial Centre, 43-47 Shan Mei Street, Fo Tan, Sha Tin, N.T., Hong Kong SAR, China. This test facility and site measurement data have been fully placed on file with the FCC and Industry Canada No.: 2042H, CABID is "HKAP01".

1.4 Related Submittal(s) Grants

This is a single application for certification of a transceiver (5G WiFi Portion only).

TEST REPORT

EXHIBIT 2 SYSTEM TEST CONFIGURATION

2.1 Justification

For radiated emissions testing, the equipment under test (EUT) was setup to transmit / receive continuously to simplify the measurement methodology. Care was taken to ensure proper power supply voltages during testing. During testing, all cables (if any) were manipulated to produce worst case emissions.

The EUT was powered by 24VAC during test.

For the measurements, the EUT was attached to a plastic stand if necessary and placed on the wooden turntable. If the base unit attached to peripherals, they were connected and operational (as typical as possible).

The signal was maximized through rotation and placement in the three orthogonal axes. The antenna height and polarization were varied during the search for maximum signal level. The antenna height was varied from 1 to 4 meters. Radiated emissions were taken at three meters unless the signal level was too low for measurement at that distance. If necessary, a pre-amplifier was used and/or the test was conducted at a closer distance.

For any intentional radiator powered by AC power line, measurements of the radiated signal level of the fundamental frequency component of the emission was performed with the supply voltage varied between 85% and 115% of the nominal rated supply voltage.

Radiated emission measurement for transmitter were performed from the lowest radio frequency signal generated in the device which is greater than 9 kHz to the tenth harmonic of the highest fundamental frequency or to 40 GHz, whichever is lower.

Emission that are directly caused by digital circuits in the transmit path and transmitter portion were measured, and the limit are according to FCC Part 15 Section 15.209 / RSS-247 Section 2.5. Digital circuitries used to control additional functions other than the operation of the transmitter are subject to FCC Part 15 Section 15.109 / RSS-247 Section 5.5 Limits.

Detector function for radiated emissions was in peak mode. Average readings, when required, were taken by measuring the duty cycle of the equipment under test and subtracting the corresponding amount in dB from the measured peak readings. A detailed description for the calculation of the average factor can be found in section 4.8.3.

Determination of pulse desensitization was made according to Hewlett Packard Application Note 150-2, Spectrum Analysis... Pulsed RF. The effective period (Teff) was referred to Exhibit 4.8.3. With the resolution bandwidth 1MHz and spectrum analyzer IF bandwidth 3dB, the pulse desensitization factor was 0dB.

For AC power line-conducted emission test, the EUT along with its peripherals were placed on a 1.0m(W)x1.5m(L) and 0.8m in height wooden table and the EUT was adjusted to maintain a 0.4 meter space from a vertical reference plane. The EUT was connected to power mains through a line impedance stabilization network (LISN), which provided 50ohm coupling impedance for measuring

TEST REPORT

instrument. The LISN housing, measuring instrument case, reference ground plane, and vertical ground plane were bounded together. The excess power cable between the EUT and the LISN was bundled.

All connecting cables of EUT and peripherals were manipulated to find the maximum emission.

Different data rates have been tested. Worst case is reported only.

All relevant operation modes have been tested, and the worst case data is included in this report.

All data rates were tested under normal mode of WiFi. Only the worst-case data is shown in the report for OFDM.

For simultaneous transmission, both Wi-Fi and BLE portions are also switched on when taking radiated emission for determining worst-case spurious emission.

2.2 EUT Exercising Software

The EUT exercise program (Tera Terms Version 4.106) used during radiated and conducted testing was designed to exercise the various system components in a manner similar to a typical use.

2.3 Description of Accessories

Description	Remark
24V AC-AC Transformer (Input: 220VAC 50Hz; Output: 24VAC 2A)	Provided by Applicant

2.4 Measurement Uncertainty

Decision Rule for compliance: For FCC/IC standard, the measured value must be within the limits of applicable standard without accounting for the measurement uncertainty. For EN/IEC/HKTA/HKTC standard, conformity rules will be used as per standard directly excepted EN/IEC 61000-3-2, EN/IEC 61000-3-3, HKTA1004, HKCA1008, HKTA1019, HKTA1020, HKTA1041 and HKTA1044.

Uncertainty and Compliance - Unless the standard specifically states that measured values are to be extended by the measurement uncertainty in determining compliance, all compliance determinations are based on the actual measured value.

TEST REPORT

EXHIBIT 3 TEST RESULTS

3.1 Maximum Conducted (RMS) Output Power at Antenna Terminals

RF Conduct Measurement Test Setup

The figure below shows the test setup, which is utilized to make these measurements.

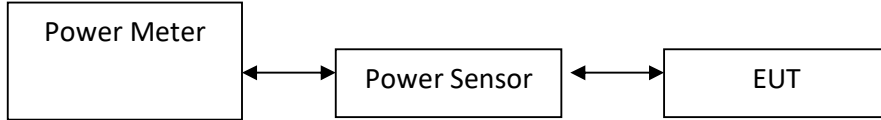

The antenna port of the EUT was connected to the input of a spectrum analyzer.

- The antenna power of the EUT was connected to the input of a power meter. Power was read directly and cable loss correction was added to the reading to the obtain power at the EUT antenna terminals. The measurement procedure E.3.A (789033 D02 General UNII Test Procedures New Rules v02r01) was used.
- The EUT should be configured to transmit continuously (at a minimum duty cycle of 98%) at full power over the measurement duration. The measurement procedure AVG1 was used.

For Maximum EIRP (Peak Antenna Gain = 0 dBi)

IEEE 802.11a (20MHz) (OFDM, 6 Mbps) (Refer to Test Data4.pdf)

Frequency (MHz)	Conducted Output Power in dBm	Conducted Output Power in mWatt	EIRP in dBm	EIRP in mWatt
5180 (P.5)	13.73	23.60	13.73	23.60
5200 (P.9)	13.79	23.93	13.79	23.93
5240 (P.13)	15.36	34.36	15.36	34.36
5260 (P.17)	13.82	24.10	13.82	24.10
5300 (P.21)	14.08	25.59	14.08	25.59
5320 (P.25)	14.20	26.30	14.20	26.30
5500 (P.29)	11.66	14.66	11.66	14.66
5580 (P.33)	10.00	10.00	10.00	10.00
5700 (P.37)	5.03	3.18	5.03	3.18
5745 (P.40)	7.62	5.78	N/A	N/A
5785 (P.44)	7.04	5.06	N/A	N/A
5825 (P.48)	7.93	6.21	N/A	N/A

TEST REPORT

IEEE 802.11n (20MHz) (OFDM, MCS0) (Refer to Test Data5.pdf)

Frequency (MHz)	Conducted Output Power in dBm	Conducted Output Power in mWatt	EIRP in dBm	EIRP in mWatt
5180 (P.5)	11.94	15.63	11.94	15.63
5200 (P.9)	11.77	15.03	11.77	15.03
5240 (P.13)	13.38	21.78	13.38	21.78
5260 (P.17)	11.81	15.17	11.81	15.17
5300 (P.21)	11.93	15.60	11.93	15.60
5320 (P.25)	12.53	17.91	12.53	17.91
5500 (P.29)	11.49	14.09	11.49	14.09
5580 (P.33)	9.84	9.64	9.84	9.64
5700 (P.37)	4.85	3.05	4.85	3.05
5745 (P.40)	8.78	7.55	N/A	N/A
5785 (P.44)	6.44	4.41	N/A	N/A
5825 (P.48)	7.64	5.81	N/A	N/A

IEEE 802.11n (40MHz) (OFDM, MCS0) (Refer to Test Data6.pdf)

Frequency (MHz)	Conducted Output Power in dBm	Conducted Output Power in mWatt	EIRP in dBm	EIRP in mWatt
5190 (P.5)	11.44	13.93	11.44	13.93
5230 (P.9)	12.94	19.68	12.94	19.68
5270 (P.13)	11.14	13.00	11.14	13.00
5310 (P.17)	11.80	15.14	11.80	15.14
5510 (P.21)	11.19	13.15	11.19	13.15
5550 (P.25)	8.20	6.61	8.20	6.61
5670 (P.29)	5.89	3.88	5.89	3.88
5755 (P.32)	7.33	5.41	N/A	N/A
5795 (P.36)	7.02	5.04	N/A	N/A

TEST REPORT

3.2 Minimum 6dB RF Bandwidth

The figure below shows the test setup, which is utilized to make these measurements.

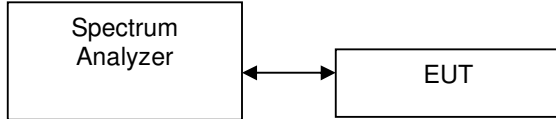

The antenna port of the EUT was connected to the input of a spectrum analyzer. The EBW measurement procedure was used. A PEAK output reading was taken, a DISPLAY line was drawn 6dB lower than PEAK level. The 6dB bandwidth was determined from where the channel output spectrum intersected the display line.

IEEE 802.11a (20MHz) (OFDM, 6 Mbps) (Refer to Test Data4.pdf)

Frequency (MHz)	6dB Bandwidth (MHz)	99% Bandwidth (MHz)
5745	16.150 (P.42)	17.228 (P.43)
5785	16.150 (P.46)	17.528 (P.47)
5825	16.150 (P.50)	17.228 (P.51)

IEEE 802.11n (20MHz) (OFDM, MCS0) (Refer to Test Data5.pdf)

Frequency (MHz)	6dB Bandwidth (MHz)	99% Bandwidth (MHz)
5745	16.450 (P.42)	18.427 (P.43)
5785	16.750 (P.46)	18.277 (P.47)
5825	17.400 (P.50)	18.127 (P.51)

IEEE 802.11n (40MHz) (OFDM, MCS0) (Refer to Test Data6.pdf)

Frequency (MHz)	6dB Bandwidth (MHz)	99% Bandwidth (MHz)
5755	35.550 (P.34)	36.500 (P.35)
5795	35.200 (P.38)	36.000 (P.39)

Limits:

6dB bandwidth shall be at least 500kHz.

TEST REPORT

3.3 26dB Bandwidth and Occupied Bandwidth

The figure below shows the test setup, which is utilized to make these measurements.

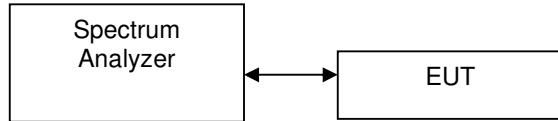

The antenna port of the EUT was connected to the input of a spectrum analyzer. The EBW measurement procedure was used. A PEAK output reading was taken, a DISPLAY line was drawn 26dB lower than PEAK level. The 26dB bandwidth was determined from where the channel output spectrum intersected the display line.

IEEE 802.11a (20MHz) (OFDM, 6 Mbps) (Refer to Test Data4.pdf)

Frequency (MHz)	26dB Bandwidth (MHz)	99% Bandwidth (MHz)
5180	34.607 (P.4)	17.678 (P.7)
5200	37.453 (P.8)	18.876 (P.11)
5240	30.262 (P.12)	17.378 (P.15)
5260	33.858 (P.16)	18.427 (P.19)
5300	30.562 (P.20)	17.079 (P.23)
5320	27.266 (P.24)	17.079 (P.27)
5500	21.423 (P.28)	17.079 (P.31)
5580	21.423 (P.32)	16.779 (P.35)
5700	22.622 (P.36)	17.079 (P.39)

IEEE 802.11n (20MHz) (OFDM, MCS0) (Refer to Test Data5.pdf)

Frequency (MHz)	26dB Bandwidth (MHz)	99% Bandwidth (MHz)
5180	28.914 (P.4)	18.277 (P.7)
5200	34.906 (P.8)	18.277 (P.11)
5240	23.670 (P.12)	18.127 (P.15)
5260	31.610 (P.16)	18.277 (P.19)
5300	22.622 (P.20)	17.978 (P.23)
5320	22.322 (P.24)	17.978 (P.27)
5500	22.472 (P.28)	18.127 (P.31)
5580	23.071 (P.32)	18.127 (P.35)
5700	22.622 (P.36)	17.828 (P.39)

TEST REPORT

IEEE 802.11n (40MHz) (OFDM, MCS0) (Refer to Test Data6.pdf)

Frequency (MHz)	26dB Bandwidth (MHz)		99% Bandwidth (MHz)	
5190	69.500	(P.4)	36.250	(P.7)
5230	40.250	(P.8)	36.000	(P.11)
5270	59.750	(P.12)	36.500	(P.15)
5310	36.000	(P.16)	36.000	(P.19)
5510	39.250	(P.20)	35.750	(P.23)
5550	40.000	(P.24)	36.250	(P.27)
5670	39.000	(P.28)	36.000	(P.31)

Limits:

26dB bandwidth shall be at least 500kHz.

TEST REPORT

3.4 Maximum Power Spectral Density

The figure below shows the test setup, which is utilized to make these measurements.

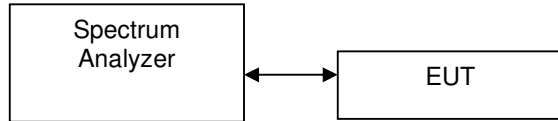

The output from the transmitter was connected to an attenuator and then to the input of the RF Spectrum Analyzer.

Spectrum analyser according to the following Settings:

For U-NII-1, U-NII-2A, U-NII-2C Band:

Using Method SA-2

- a) Set span to encompass the entire emission bandwidth (EBW) of the signal.
- b) Set RBW = 1 MHz, Set VBW \geq 3 RBW, Detector = RMS
- c) Sweep time = auto, trigger set to "free run".
- d) Trace average at least 100 traces in power averaging mode.
- e) Record the max value and add 10 log (1/duty cycle)

For U-NII-3 Band:

- a) Set span to encompass the entire emission bandwidth (EBW) of the signal.
- b) Set RBW = 500 kHz, Set VBW \geq 3 RBW, Detector = RMS
- c) Use the peak marker function to determine the maximum power level in any 500 kHz band segment within the fundamental EBW.
- d) Sweep time = auto, trigger set to "free run".
- e) Trace average at least 100 traces in power averaging mode.
- f) Record the max value and add 10 log (1/duty cycle)

Note: The cable loss and attenuator loss were offset into measure device as an amplitude offset.

TEST REPORT

For Maximum EIRP (Peak Antenna Gain = 2 dBi)

IEEE 802.11a (20MHz) (OFDM, 6 Mbps) (Refer to Test Data4.pdf)

Frequency (MHz)	PSD in 1MHz (dBm)	EIRP PSD in 1MHz (dBm)	PSD in 500kHz (dBm)
5180 (P.6)	2.948	2.948	N/A
5200 (P.10)	3.126	3.126	N/A
5240 (P.14)	4.523	4.523	N/A
5260 (P.18)	3.180	3.180	N/A
5300 (P.22)	3.566	3.566	N/A
5320 (P.26)	3.487	3.487	N/A
5500 (P.30)	1.058	1.058	N/A
5580 (P.34)	-0.595	-0.595	N/A
5700 (P.38)	-6.143	-6.143	N/A
5745 (P.41)	N/A	N/A	-3.890
5785 (P.45)	N/A	N/A	-3.974
5825 (P.49)	N/A	N/A	-3.781

IEEE 802.11n (20MHz) (OFDM, MCS0) (Refer to Test Data5.pdf)

Frequency (MHz)	PSD in 1MHz (dBm)	EIRP PSD in 1MHz (dBm)	PSD in 500kHz (dBm)
5180 (P.6)	1.031	1.031	N/A
5200 (P.10)	1.145	1.145	N/A
5240 (P.14)	2.580	2.580	N/A
5260 (P.18)	0.897	0.897	N/A
5300 (P.22)	0.500	0.500	N/A
5320 (P.26)	2.244	2.244	N/A
5500 (P.30)	0.610	0.610	N/A
5580 (P.34)	-0.781	-0.781	N/A
5700 (P.38)	-6.396	-6.396	N/A
5745 (P.41)	N/A	N/A	-3.362
5785 (P.45)	N/A	N/A	-5.145
5825 (P.49)	N/A	N/A	-3.820

TEST REPORT

IEEE 802.11n (40MHz) (OFDM, MCS0) (Refer to Test Data6.pdf)

Frequency (MHz)	PSD in 1MHz (dBm)	EIRP PSD in 1MHz (dBm)	PSD in 500kHz (dBm)
5190 (P.6)	-0.790	-0.790	N/A
5230 (P.10)	0.051	0.051	N/A
5270 (P.14)	-1.156	-1.156	N/A
5310 (P.18)	0.441	0.441	N/A
5510 (P.22)	-1.078	-1.078	N/A
5550 (P.26)	-3.941	-3.941	N/A
5670 (P.30)	-5.815	-5.815	N/A
5755 (P.33)	N/A	N/A	-7.290
5795 (P.37)	N/A	N/A	-6.327

Remark:

1. Cable Loss: 0.5dB
2. e.i.r.p = Power Spectral Density + Duty Cycle Factor + Antenna Gain
3. Power Spectral Density = Power Spectral Density + Duty Cycle Factor
4. Duty Cycle = On Time/ Period
 Duty Cycle Factor = $10 * \log (1/ \text{Duty Cycle})$
 Average factor = $20 \log 10 \text{ Duty Cycle}$.

Limits for FCC:

For U-NII-1: 11dBm/MHz for mobile/portable device

For U-NII-2: 11dBm/MHz

For U-NII-3 in 3kHz: 30dBm/500kHz

Limits for RSS:

For U-NII-1: 10dBm/MHz E.I.R.P

For U-NII-2: 11dBm/MHz

For U-NII-3 in 3kHz: 30dBm/500kHz

TEST REPORT

3.5 Field Strength Calculation

The field strength is calculated by adding the reading on the Spectrum Analyzer to the factors associated with preamplifiers (if any), antennas, cables, pulse desensitization and average factors (when specified limit is in average and measurements are made with peak detectors). A sample calculation is included below.

$$FS = RA + AF + CF - AG + PD + AV$$

Where	FS	=	Field Strength in dB μ V/m
	RA	=	Receiver Amplitude (including preamplifier) in dB μ V
	CF	=	Cable Attenuation Factor in dB
	AF	=	Antenna Factor in dB
	AG	=	Amplifier Gain in dB
	PD	=	Pulse Desensitization in dB
	AV	=	Average Factor in -dB

In the radiated emission table which follows, the reading shown on the data table may reflect the preamplifier gain. An example of the calculations, where the reading does not reflect the preamplifier gain, follows:

$$FS = RA + AF + CF - AG + PD + AV$$

Example:

Assume a receiver reading of 62.0 dB μ V is obtained. The antenna factor of 7.4 dB and cable factor of 1.6 dB is added. The amplifier gain of 29.0 dB is subtracted. The pulse desensitization factor of the spectrum analyzer is 0.0 dB, and the resultant average factor is -10.0 dB. The net field strength for comparison to the appropriate emission limit is 32.0 dB μ V/m. This value in dB μ V/m is converted to its corresponding level in μ V/m.

$$\begin{aligned} RA &= 62.0 \text{ dB}\mu\text{V} \\ AF &= 7.4 \text{ dB} \\ CF &= 1.6 \text{ dB} \\ AG &= 29.0 \text{ dB} \\ PD &= 0.0 \text{ dB} \\ AV &= -10.0 \text{ dB} \\ FS &= 62.0 + 7.4 + 1.6 - 29.0 + 0.0 + (-10.0) = 32.0 \text{ dB}\mu\text{V/m} \end{aligned}$$

$$\text{Level in } \mu\text{V/m} = \text{Common Antilogarithm } [(32.0 \text{ dB}\mu\text{V/m})/20] = 39.8 \mu\text{V/m}$$

TEST REPORT

3.6 Transmitter Radiated Emissions in Restricted Bands and Spurious Emissions

Data is included of the worst case configuration (the configuration which resulted in the highest emission levels). A sample calculation, configuration photographs and data tables of the emissions are included.

The data on the following pages list the significant emission frequencies, the limit and the margin of compliance.

3.6.1 Radiated Emission Configuration Photograph

Worst Case Restricted Band Radiated Emission at 10520 MHz.

The worst case radiated emission configuration photographs are saved with filename:
config photos.pdf

3.6.2 Radiated Emission Data

The data in below tables list the significant emission frequencies, the limit and the margin of compliance.

Judgement – Passed by 0.1 dB margin

TEST REPORT

3.6.3 Radiated Emission Test Setup

The figure below shows the test setup, which is utilized to make these measurements.

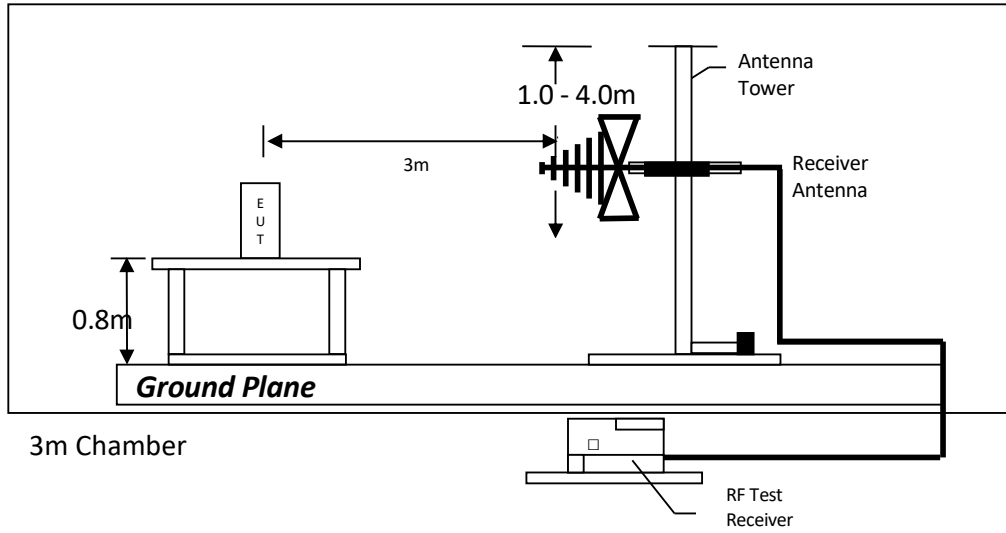

Test setup of radiated emissions up to 1GHz

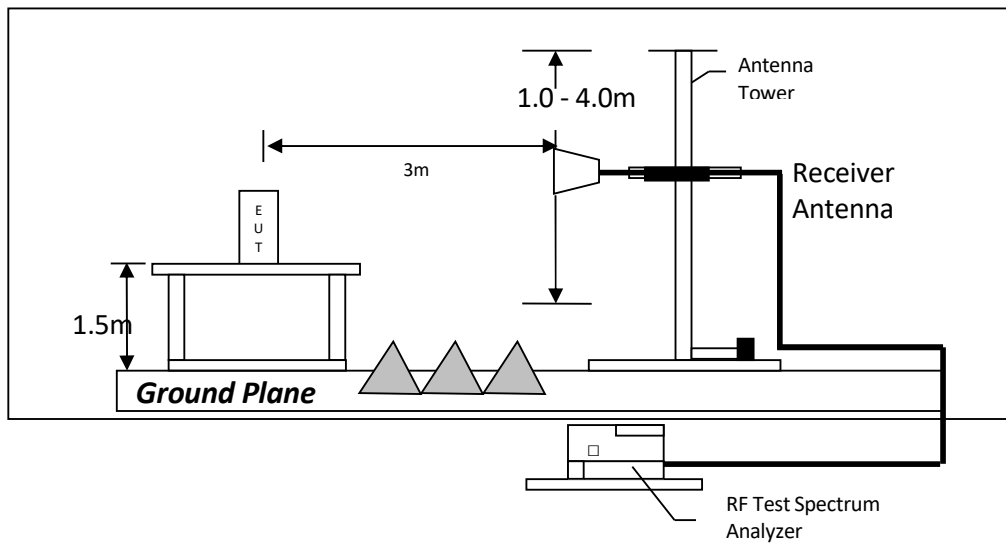

Test setup of radiated emissions above 1GHz

TEST REPORT

RADIATED EMISSION DATA

IEEE 802.11a (20MHz) (OFDM,6MBs)

5180MHz

Polarization	Frequency (MHz)	Reading (dBμV)	Pre-Amp Gain (dB)	Antenna Factor (dB)	Net at 3m - Average (dBμV/m)	Average Factor (dB)	Calculated at 3m (dBμV/m)	Average Limit at 3m (dBμV/m)	Margin (dB)
V	5150.000	39.6	33	35.7	42.3	0	42.3	54.0	-11.7
V	10360.000	48.1	33	40.5	55.6	0	55.6	68.0	-12.4
V	15540.000	40.0	33	37.7	44.7	0	44.7	68.0	-23.3
V	20720.000	40.5	33	37.7	45.2	0	45.2	54.0	-8.8
V	25900.000	49.3	33	39.3	55.6	0	55.6	68.0	-12.4
H	31080.000	41.8	33	42.1	50.9	0	50.9	68.0	-17.1

Polarization	Frequency (MHz)	Reading (dBμV)	Pre-Amp Gain (dB)	Antenna Factor (dB)	Net at 3m - Peak (dBμV/m)	Peak Limit at 3m (dBμV/m)	Margin (dB)
V	5150.000	53.6	33	35.7	56.3	74.0	-17.7
V	10360.000	60.2	33	40.5	67.7	68.0	-0.3
V	15540.000	53.8	33	37.7	58.5	68.0	-9.5
V	20720.000	60.5	33	37.7	65.2	74.0	-8.8
V	25900.000	58.4	33	39.3	64.7	68.0	-3.3
H	31080.000	55.8	33	42.1	64.9	68.0	-3.1

5200MHz

Polarization	Frequency (MHz)	Reading (dBμV)	Pre-Amp Gain (dB)	Antenna Factor (dB)	Net at 3m - Average (dBμV/m)	Average Factor (dB)	Calculated at 3m (dBμV/m)	Average Limit at 3m (dBμV/m)	Margin (dB)
H	10400.000	36.3	33	40.5	43.8	0	43.8	68.0	-24.2
H	15600.000	48.7	33	37.7	53.4	0	53.4	54.0	-0.6
H	20800.000	47.6	33	37.7	52.3	0	52.3	54.0	-1.7
V	26000.000	45.6	33	39.2	51.8	0	51.8	68.0	-16.2
V	31200.000	37.5	33	42.1	46.6	0	46.6	54.0	-7.4

Polarization	Frequency (MHz)	Reading (dBμV)	Pre-Amp Gain (dB)	Antenna Factor (dB)	Net at 3m - Peak (dBμV/m)	Peak Limit at 3m (dBμV/m)	Margin (dB)
H	10400.000	50.1	33	40.5	57.6	68.0	-10.4
H	15600.000	64.2	33	37.7	68.9	74.0	-5.1
H	20800.000	59.6	33	37.7	64.3	74.0	-9.7
V	26000.000	58.1	33	39.2	64.3	68.0	-3.7
V	31200.000	52.7	33	42.1	61.8	74.0	-12.2

TEST REPORT

RADIATED EMISSION DATA

IEEE 802.11a (20MHz) (OFDM,6MBs)

5240MHz

Polarization	Frequency (MHz)	Reading (dB μ V)	Pre-Amp Gain (dB)	Antenna Factor (dB)	Net at 3m - Average (dB μ V/m)	Average Factor (dB)	Calculated at 3m (dB μ V/m)	Average Limit at 3m (dB μ V/m)	Margin (dB)
V	10480.000	45.5	33	40.5	53.0	0	53.0	68.0	-15.0
V	15720.000	41.1	33	37.7	45.8	0	45.8	54.0	-8.2
V	20960.000	45.7	33	37.7	50.4	0	50.4	54.0	-3.6
H	26200.000	44.4	33	39.2	50.6	0	50.6	68.0	-17.4
H	31440.000	43.1	33	42.1	52.2	0	52.2	54.0	-1.8

Polarization	Frequency (MHz)	Reading (dB μ V)	Pre-Amp Gain (dB)	Antenna Factor (dB)	Net at 3m - Peak (dB μ V/m)	Peak Limit at 3m (dB μ V/m)	Margin (dB)
V	10480.000	60.1	33	40.5	67.6	68.0	-0.4
V	15720.000	54.3	33	37.7	59.0	74.0	-15.0
V	20960.000	58.8	33	37.7	63.5	74.0	-10.5
H	26200.000	61.5	33	39.2	67.7	68.0	-0.3
H	31440.000	57.6	33	42.1	66.7	74.0	-7.3

5260MHz

Polarization	Frequency (MHz)	Reading (dB μ V)	Pre-Amp Gain (dB)	Antenna Factor (dB)	Net at 3m - Average (dB μ V/m)	Average Factor (dB)	Calculated at 3m (dB μ V/m)	Average Limit at 3m (dB μ V/m)	Margin (dB)
V	10520.000	46.2	33	40.4	53.6	0	53.6	68.0	-14.4
V	15780.000	42.6	33	37.7	47.3	0	47.3	54.0	-6.7
H	21040.000	43.7	33	37.9	48.6	0	48.6	54.0	-5.4
V	26300.000	42.0	33	39.2	48.2	0	48.2	68.0	-19.8
V	31560.000	45.9	33	40.4	53.3	0	53.3	54.0	-0.7

Polarization	Frequency (MHz)	Reading (dB μ V)	Pre-Amp Gain (dB)	Antenna Factor (dB)	Net at 3m - Peak (dB μ V/m)	Peak Limit at 3m (dB μ V/m)	Margin (dB)
V	10520.000	60.5	33	40.4	67.9	68.0	-0.1
V	15780.000	56.1	33	37.7	60.8	74.0	-13.2
H	21040.000	58.6	33	37.9	63.5	74.0	-10.5
V	26300.000	55.5	33	39.2	61.7	68.0	-6.3
V	31560.000	62.4	33	40.4	69.8	74.0	-4.2

TEST REPORT

RADIATED EMISSION DATA

IEEE 802.11a (20MHz) (OFDM,6MBs)

5300MHz

Polarization	Frequency (MHz)	Reading (dBμV)	Pre-Amp Gain (dB)	Antenna Factor (dB)	Net at 3m - Average (dBμV/m)	Average Factor (dB)	Calculated at 3m (dBμV/m)	Average Limit at 3m (dBμV/m)	Margin (dB)
V	10600.000	46.2	33	40.4	53.6	0	53.6	54.0	-0.4
V	15900.000	41.6	33	37.7	46.3	0	46.3	54.0	-7.7
V	21200.000	46.2	33	37.9	51.1	0	51.1	54.0	-2.9
H	26500.000	45.2	33	39.9	52.1	0	52.1	68.0	-15.9
H	31800.000	45.0	33	40.4	52.4	0	52.4	54.0	-1.6

Polarization	Frequency (MHz)	Reading (dBμV)	Pre-Amp Gain (dB)	Antenna Factor (dB)	Net at 3m - Peak (dBμV/m)	Peak Limit at 3m (dBμV/m)	Margin (dB)
V	10600.000	61.7	33	40.4	69.1	74.0	-4.9
V	15900.000	54.9	33	37.7	59.6	74.0	-14.4
V	21200.000	58.6	33	37.9	63.5	74.0	-10.5
H	26500.000	57.3	33	39.9	64.2	68.0	-3.8
H	31800.000	58.3	33	40.4	65.7	74.0	-8.3

5320MHz

Polarization	Frequency (MHz)	Reading (dBμV)	Pre-Amp Gain (dB)	Antenna Factor (dB)	Net at 3m - Average (dBμV/m)	Average Factor (dB)	Calculated at 3m (dBμV/m)	Average Limit at 3m (dBμV/m)	Margin (dB)
V	5350.000	38.4	33	35.7	41.1	0	41.1	54.0	-12.9
V	10640.000	46.4	33	40.4	53.8	0	53.8	54.0	-0.2
V	15960.000	42.0	33	37.7	46.7	0	46.7	54.0	-7.3
V	21280.000	47.4	33	37.9	52.3	0	52.3	54.0	-1.7
V	26600.000	40.6	33	39.9	47.5	0	47.5	68.0	-20.5
H	31920.000	44.4	33	40.4	51.8	0	51.8	68.0	-16.2

Polarization	Frequency (MHz)	Reading (dBμV)	Pre-Amp Gain (dB)	Antenna Factor (dB)	Net at 3m - Peak (dBμV/m)	Peak Limit at 3m (dBμV/m)	Margin (dB)
V	5350.000	52.2	33	35.7	54.9	74.0	-19.1
V	10640.000	61.1	33	40.4	68.5	74.0	-5.5
V	15960.000	55.7	33	37.7	60.4	74.0	-13.6
V	21280.000	63.1	33	37.9	68.0	74.0	-6.0
V	26600.000	55.9	33	39.9	62.8	68.0	-5.2
H	31920.000	58.9	33	40.4	66.3	68.0	-1.7

TEST REPORT

RADIATED EMISSION DATA

IEEE 802.11a (20MHz) (OFDM,6MBs)

5500MHz

Polarization	Frequency (MHz)	Reading (dBμV)	Pre-Amp Gain (dB)	Antenna Factor (dB)	Net at 3m - Average (dBμV/m)	Average Factor (dB)	Calculated at 3m (dBμV/m)	Average Limit at 3m (dBμV/m)	Margin (dB)
V	5470.000	38.2	33	35.7	40.9	0	40.9	68.0	-27.1
H	11000.000	43.9	33	40.8	51.7	0	51.7	54.0	-2.3
H	16500.000	38.9	33	37.6	43.5	0	43.5	68.0	-24.5
H	22000.000	43.5	33	38.2	48.7	0	48.7	68.0	-19.3
V	27500.000	38.3	33	40.0	45.3	0	45.3	68.0	-22.7
V	33000.000	43.6	33	40.8	51.4	0	51.4	68.0	-16.6

Polarization	Frequency (MHz)	Reading (dBμV)	Pre-Amp Gain (dB)	Antenna Factor (dB)	Net at 3m - Peak (dBμV/m)	Peak Limit at 3m (dBμV/m)	Margin (dB)
V	5470.000	51.8	33	35.7	54.5	68.0	-13.5
H	11000.000	57.4	33	40.8	65.2	74.0	-8.8
H	16500.000	52.6	33	37.6	57.2	68.0	-10.8
H	22000.000	55.2	33	38.2	60.4	68.0	-7.6
V	27500.000	52.2	33	40.0	59.2	68.0	-8.8
V	33000.000	56.2	33	40.8	64.0	68.0	-4.0

5580MHz

Polarization	Frequency (MHz)	Reading (dBμV)	Pre-Amp Gain (dB)	Antenna Factor (dB)	Net at 3m - Average (dBμV/m)	Average Factor (dB)	Calculated at 3m (dBμV/m)	Average Limit at 3m (dBμV/m)	Margin (dB)
H	11160.000	43.5	33	40.8	51.3	0	51.3	54.0	-2.7
H	16740.000	40.5	33	37.6	45.1	0	45.1	68.0	-22.9
V	22320.000	43.9	33	38.2	49.1	0	49.1	54.0	-4.9
H	27900.000	39.7	33	40.0	46.7	0	46.7	68.0	-21.3
H	33480.000	44.0	33	40.8	51.8	0	51.8	68.0	-16.2

Polarization	Frequency (MHz)	Reading (dBμV)	Pre-Amp Gain (dB)	Antenna Factor (dB)	Net at 3m - Peak (dBμV/m)	Peak Limit at 3m (dBμV/m)	Margin (dB)
H	11160.000	57.3	33	40.8	65.1	74.0	-8.9
H	16740.000	53.7	33	37.6	58.3	68.0	-9.7
V	22320.000	57.8	33	38.2	63.0	74.0	-11.0
H	27900.000	57.2	33	40.0	64.2	68.0	-3.8
H	33480.000	55.9	33	40.8	63.7	68.0	-4.3

TEST REPORT

RADIATED EMISSION DATA

IEEE 802.11a (20MHz) (OFDM,6MBs)

5700MHz

Polarization	Frequency (MHz)	Reading (dB μ V)	Pre-Amp Gain (dB)	Antenna Factor (dB)	Net at 3m - Average (dB μ V/m)	Average Factor (dB)	Calculated at 3m (dB μ V/m)	Average Limit at 3m (dB μ V/m)	Margin (dB)
V	11400.000	42.6	33	40.8	50.4	0	50.4	54.0	-3.6
V	17100.000	42.0	33	37.6	46.6	0	46.6	68.0	-21.4
V	22800.000	43.3	33	38.3	48.6	0	48.6	54.0	-5.4
V	28500.000	41.6	33	40.1	48.7	0	48.7	68.0	-19.3
H	34200.000	39.2	33	41.1	47.3	0	47.3	68.0	-20.7

Polarization	Frequency (MHz)	Reading (dB μ V)	Pre-Amp Gain (dB)	Antenna Factor (dB)	Net at 3m - Peak (dB μ V/m)	Peak Limit at 3m (dB μ V/m)	Margin (dB)
V	11400.000	56.6	33	40.8	64.4	74.0	-9.6
V	17100.000	55.6	33	37.6	60.2	68.0	-7.8
V	22800.000	57.1	33	38.3	62.4	74.0	-11.6
V	28500.000	57.1	33	40.1	64.2	68.0	-3.8
H	34200.000	54.4	33	41.1	62.5	68.0	-5.5

5745MHz

Polarization	Frequency (MHz)	Reading (dB μ V)	Pre-Amp Gain (dB)	Antenna Factor (dB)	Net at 3m - Average (dB μ V/m)	Average Factor (dB)	Calculated at 3m (dB μ V/m)	Average Limit at 3m (dB μ V/m)	Margin (dB)
H	11490.000	43.4	33	40.8	51.2	0	51.2	54.0	-2.8
H	17235.000	41.4	33	37.6	46.0	0	46.0	68.0	-22.0
V	22980.000	43.6	33	38.3	48.9	0	48.9	54.0	-5.1
H	28725.000	43.2	33	40.1	50.3	0	50.3	68.0	-17.7
H	34470.000	39.7	33	41.1	47.8	0	47.8	68.0	-20.2

Polarization	Frequency (MHz)	Reading (dB μ V)	Pre-Amp Gain (dB)	Antenna Factor (dB)	Net at 3m - Peak (dB μ V/m)	Peak Limit at 3m (dB μ V/m)	Margin (dB)
H	11490.000	57.8	33	40.8	65.6	74.0	-8.4
H	17235.000	54.7	33	37.6	59.3	68.0	-8.7
V	22980.000	60.3	33	38.3	65.6	74.0	-8.4
H	28725.000	53.9	33	40.1	61.0	68.0	-7.0
H	34470.000	57.8	33	41.1	65.9	68.0	-2.1

TEST REPORT

RADIATED EMISSION DATA

IEEE 802.11a (20MHz) (OFDM,6MBs)

5785MHz

Polarization	Frequency (MHz)	Reading (dBμV)	Pre-Amp Gain (dB)	Antenna Factor (dB)	Net at 3m - Average (dBμV/m)	Average Factor (dB)	Calculated at 3m (dBμV/m)	Average Limit at 3m (dBμV/m)	Margin (dB)
V	11570.000	45.1	33	40.5	52.6	0	52.6	54.0	-1.4
V	17355.000	44.4	33	37.6	49.0	0	49.0	68.0	-19.0
H	23140.000	44.9	33	38.6	50.5	0	50.5	68.0	-17.5
V	28925.000	42.4	33	40.1	49.5	0	49.5	68.0	-18.5
V	34710.000	42.3	33	41.3	50.6	0	50.6	68.0	-17.4

Polarization	Frequency (MHz)	Reading (dBμV)	Pre-Amp Gain (dB)	Antenna Factor (dB)	Net at 3m - Peak (dBμV/m)	Peak Limit at 3m (dBμV/m)	Margin (dB)
V	11570.000	59.9	33	40.5	67.4	74.0	-6.6
V	17355.000	57.8	33	37.6	62.4	68.0	-5.6
H	23140.000	60.2	33	38.6	65.8	68.0	-2.2
V	28925.000	57.7	33	40.1	64.8	68.0	-3.2
V	34710.000	59.4	33	41.3	67.7	68.0	-0.3

5825MHz

Polarization	Frequency (MHz)	Reading (dBμV)	Pre-Amp Gain (dB)	Antenna Factor (dB)	Net at 3m - Average (dBμV/m)	Average Factor (dB)	Calculated at 3m (dBμV/m)	Average Limit at 3m (dBμV/m)	Margin (dB)
V	11650.000	46.3	33	40.5	53.8	0	53.8	54.0	-0.2
V	17475.000	43.4	33	37.6	48.0	0	48.0	68.0	-20.0
H	23300.000	45.7	33	38.6	51.3	0	51.3	68.0	-16.7
H	29125.000	45.9	33	40.0	52.9	0	52.9	68.0	-15.1
V	34950.000	44.6	33	41.3	52.9	0	52.9	68.0	-15.1

Polarization	Frequency (MHz)	Reading (dBμV)	Pre-Amp Gain (dB)	Antenna Factor (dB)	Net at 3m - Peak (dBμV/m)	Peak Limit at 3m (dBμV/m)	Margin (dB)
V	11650.000	63.6	33	40.5	71.1	74.0	-2.9
V	17475.000	56.4	33	37.6	61.0	68.0	-7.0
H	23300.000	59.5	33	38.6	65.1	68.0	-2.9
H	29125.000	58.7	33	40.0	65.7	68.0	-2.3
V	34950.000	58.0	33	41.3	66.3	68.0	-1.7

- Notes:
1. Peak detector is used for the emission measurement.
 2. All measurements were made at 3 meters.
 3. Negative value in the margin column shows emission below limit.
 4. Horn antenna is used for the emission over 1000MHz.
 5. Emissions within the restricted band meets the requirement of FCC Part 15 Section 15.205.
 6. Measurement Uncertainty is ±5.3dB at a level of confidence of 95%.
 7. For the measurement of radiated emission, summation method was used which numerical integrating (in terms of linear power) over the transmitter occupied bandwidth.
 8. For the linear power measurement, data in 1MHz spacing was collected by spectrum analyzer with 1MHz resolution bandwidth.
 9. Average detector is used according to ANSI C63.10 for average measurement.

TEST REPORT

RADIATED EMISSION DATA

IEEE 802.11n (HT20MHz) (MCS0)

5180MHz

Polarization	Frequency (MHz)	Reading (dBμV)	Pre-Amp Gain (dB)	Antenna Factor (dB)	Net at 3m - Average (dBμV/m)	Average Factor (dB)	Calculated at 3m (dBμV/m)	Average Limit at 3m (dBμV/m)	Margin (dB)
V	5150.000	38.5	33	35.7	41.2	0	41.2	54.0	-12.8
V	10360.000	41.2	33	40.5	48.7	0	48.7	68.0	-19.3
V	15540.000	39.7	33	37.7	44.4	0	44.4	68.0	-23.6
H	20720.000	43.3	33	37.7	48.0	0	48.0	54.0	-6.0
V	25900.000	42.1	33	39.3	48.4	0	48.4	68.0	-19.6
H	31080.000	38.1	33	42.1	47.2	0	47.2	68.0	-20.8

Polarization	Frequency (MHz)	Reading (dBμV)	Pre-Amp Gain (dB)	Antenna Factor (dB)	Net at 3m - Peak (dBμV/m)	Peak Limit at 3m (dBμV/m)	Margin (dB)
V	5150.000	52.2	33	35.7	54.9	74.0	-19.1
V	10360.000	55.2	33	40.5	62.7	68.0	-5.3
V	15540.000	53.3	33	37.7	58.0	68.0	-10.0
H	20720.000	54.8	33	37.7	59.5	74.0	-14.5
V	25900.000	55.6	33	39.3	61.9	68.0	-6.1
H	31080.000	52.7	33	42.1	61.8	68.0	-6.2

5200MHz

Polarization	Frequency (MHz)	Reading (dBμV)	Pre-Amp Gain (dB)	Antenna Factor (dB)	Net at 3m - Average (dBμV/m)	Average Factor (dB)	Calculated at 3m (dBμV/m)	Average Limit at 3m (dBμV/m)	Margin (dB)
V	10400.000	41.3	33	40.5	48.8	0	48.8	68.0	-19.2
V	15600.000	38.6	33	37.7	43.3	0	43.3	54.0	-10.7
V	20800.000	41.1	33	37.7	45.8	0	45.8	54.0	-8.2
H	26000.000	42.0	33	39.2	48.2	0	48.2	68.0	-19.8
V	31200.000	35.0	33	42.1	44.1	0	44.1	54.0	-9.9

Polarization	Frequency (MHz)	Reading (dBμV)	Pre-Amp Gain (dB)	Antenna Factor (dB)	Net at 3m - Peak (dBμV/m)	Peak Limit at 3m (dBμV/m)	Margin (dB)
V	10400.000	55.1	33	40.5	62.6	68.0	-5.4
V	15600.000	52.0	33	37.7	56.7	74.0	-17.3
V	20800.000	54.4	33	37.7	59.1	74.0	-14.9
H	26000.000	52.4	33	39.2	58.6	68.0	-9.4
V	31200.000	51.9	33	42.1	61.0	74.0	-13.0

TEST REPORT

RADIATED EMISSION DATA

IEEE 802.11n (HT20MHz) (MCS0)

5240MHz

Polarization	Frequency (MHz)	Reading (dB μ V)	Pre-Amp Gain (dB)	Antenna Factor (dB)	Net at 3m - Average (dB μ V/m)	Average Factor (dB)	Calculated at 3m (dB μ V/m)	Average Limit at 3m (dB μ V/m)	Margin (dB)
H	10480.000	38.5	33	40.5	46.0	0	46.0	68.0	-22.0
H	15720.000	40.9	33	37.7	45.6	0	45.6	54.0	-8.4
V	20960.000	42.2	33	37.7	46.9	0	46.9	54.0	-7.1
V	26200.000	40.3	33	39.2	46.5	0	46.5	68.0	-21.5
H	31440.000	37.7	33	42.1	46.8	0	46.8	54.0	-7.2

Polarization	Frequency (MHz)	Reading (dB μ V)	Pre-Amp Gain (dB)	Antenna Factor (dB)	Net at 3m - Peak (dB μ V/m)	Peak Limit at 3m (dB μ V/m)	Margin (dB)
H	10480.000	52.4	33	40.5	59.9	68.0	-8.1
H	15720.000	57.9	33	37.7	62.6	74.0	-11.4
V	20960.000	55.9	33	37.7	60.6	74.0	-13.4
V	26200.000	56.3	33	39.2	62.5	68.0	-5.5
H	31440.000	50.9	33	42.1	60.0	74.0	-14.0

5260MHz

Polarization	Frequency (MHz)	Reading (dB μ V)	Pre-Amp Gain (dB)	Antenna Factor (dB)	Net at 3m - Average (dB μ V/m)	Average Factor (dB)	Calculated at 3m (dB μ V/m)	Average Limit at 3m (dB μ V/m)	Margin (dB)
V	10520.000	42.9	33	40.4	50.3	0	50.3	68.0	-17.7
V	15780.000	42.3	33	37.7	47.0	0	47.0	54.0	-7.0
H	21040.000	42.5	33	37.9	47.4	0	47.4	54.0	-6.6
H	26300.000	44.6	33	39.2	50.8	0	50.8	68.0	-17.2
V	31560.000	42.7	33	40.4	50.1	0	50.1	54.0	-3.9

Polarization	Frequency (MHz)	Reading (dB μ V)	Pre-Amp Gain (dB)	Antenna Factor (dB)	Net at 3m - Peak (dB μ V/m)	Peak Limit at 3m (dB μ V/m)	Margin (dB)
V	10520.000	56.5	33	40.4	63.9	68.0	-4.1
V	15780.000	55.4	33	37.7	60.1	74.0	-13.9
H	21040.000	56.1	33	37.9	61.0	74.0	-13.0
H	26300.000	54.8	33	39.2	61.0	68.0	-7.0
V	31560.000	53.6	33	40.4	61.0	74.0	-13.0

TEST REPORT

RADIATED EMISSION DATA

IEEE 802.11n (HT20MHz) (MCS0)

5300MHz

Polarization	Frequency (MHz)	Reading (dB μ V)	Pre-Amp Gain (dB)	Antenna Factor (dB)	Net at 3m - Average (dB μ V/m)	Average Factor (dB)	Calculated at 3m (dB μ V/m)	Average Limit at 3m (dB μ V/m)	Margin (dB)
H	10600.000	36.0	33	40.4	43.4	0	43.4	54.0	-10.6
H	15900.000	40.8	33	37.7	45.5	0	45.5	54.0	-8.5
H	21200.000	39.4	33	37.9	44.3	0	44.3	54.0	-9.7
V	26500.000	38.0	33	39.9	44.9	0	44.9	68.0	-23.1
V	31800.000	38.2	33	40.4	45.6	0	45.6	54.0	-8.4

Polarization	Frequency (MHz)	Reading (dB μ V)	Pre-Amp Gain (dB)	Antenna Factor (dB)	Net at 3m - Peak (dB μ V/m)	Peak Limit at 3m (dB μ V/m)	Margin (dB)
H	10600.000	49.7	33	40.4	57.1	74.0	-16.9
H	15900.000	54.1	33	37.7	58.8	74.0	-15.2
H	21200.000	53.9	33	37.9	58.8	74.0	-15.2
V	26500.000	51.4	33	39.9	58.3	68.0	-9.7
V	31800.000	50.7	33	40.4	58.1	74.0	-15.9

5320MHz

Polarization	Frequency (MHz)	Reading (dB μ V)	Pre-Amp Gain (dB)	Antenna Factor (dB)	Net at 3m - Average (dB μ V/m)	Average Factor (dB)	Calculated at 3m (dB μ V/m)	Average Limit at 3m (dB μ V/m)	Margin (dB)
H	5350.000	38.2	33	35.7	40.9	0	40.9	54.0	-13.1
V	10640.000	39.7	33	40.4	47.1	0	47.1	54.0	-6.9
V	15960.000	41.2	33	37.7	45.9	0	45.9	54.0	-8.1
H	21280.000	41.6	33	37.9	46.5	0	46.5	54.0	-7.5
V	26600.000	39.6	33	39.9	46.5	0	46.5	68.0	-21.5
H	31920.000	40.1	33	40.4	47.5	0	47.5	68.0	-20.5

Polarization	Frequency (MHz)	Reading (dB μ V)	Pre-Amp Gain (dB)	Antenna Factor (dB)	Net at 3m - Peak (dB μ V/m)	Peak Limit at 3m (dB μ V/m)	Margin (dB)
H	5350.000	51.5	33	35.7	54.2	74.0	-19.8
V	10640.000	53.7	33	40.4	61.1	74.0	-12.9
V	15960.000	54.8	33	37.7	59.5	74.0	-14.5
H	21280.000	55.1	33	37.9	60.0	74.0	-14.0
V	26600.000	54.4	33	39.9	61.3	68.0	-6.7
H	31920.000	54.1	33	40.4	61.5	68.0	-6.5

TEST REPORT

RADIATED EMISSION DATA

IEEE 802.11n (HT20MHz) (MCS0)

5500MHz

Polarization	Frequency (MHz)	Reading (dBμV)	Pre-Amp Gain (dB)	Antenna Factor (dB)	Net at 3m - Average (dBμV/m)	Average Factor (dB)	Calculated at 3m (dBμV/m)	Average Limit at 3m (dBμV/m)	Margin (dB)
H	5470.000	37.9	33	35.7	40.6	0	40.6	68.0	-27.4
V	11000.000	42.9	33	40.8	50.7	0	50.7	54.0	-3.3
V	16500.000	38.5	33	37.6	43.1	0	43.1	68.0	-24.9
H	22000.000	44.6	33	38.2	49.8	0	49.8	68.0	-18.2
V	27500.000	40.1	33	40.0	47.1	0	47.1	68.0	-20.9
V	33000.000	42.2	33	40.8	50.0	0	50.0	68.0	-18.0

Polarization	Frequency (MHz)	Reading (dBμV)	Pre-Amp Gain (dB)	Antenna Factor (dB)	Net at 3m - Peak (dBμV/m)	Peak Limit at 3m (dBμV/m)	Margin (dB)
H	5470.000	51.9	33	35.7	54.6	68.0	-13.4
V	11000.000	55.8	33	40.8	63.6	74.0	-10.4
V	16500.000	56.1	33	37.6	60.7	68.0	-7.3
H	22000.000	57.6	33	38.2	62.8	68.0	-5.2
V	27500.000	54.7	33	40.0	61.7	68.0	-6.3
V	33000.000	55.7	33	40.8	63.5	68.0	-4.5

5580MHz

Polarization	Frequency (MHz)	Reading (dBμV)	Pre-Amp Gain (dB)	Antenna Factor (dB)	Net at 3m - Average (dBμV/m)	Average Factor (dB)	Calculated at 3m (dBμV/m)	Average Limit at 3m (dBμV/m)	Margin (dB)
V	11160.000	40.4	33	40.8	48.2	0	48.2	54.0	-5.8
V	16740.000	40.5	33	37.6	45.1	0	45.1	68.0	-22.9
V	22320.000	42.7	33	38.2	47.9	0	47.9	54.0	-6.1
V	27900.000	40.4	33	40.0	47.4	0	47.4	68.0	-20.6
H	33480.000	39.7	33	40.8	47.5	0	47.5	68.0	-20.5

Polarization	Frequency (MHz)	Reading (dBμV)	Pre-Amp Gain (dB)	Antenna Factor (dB)	Net at 3m - Peak (dBμV/m)	Peak Limit at 3m (dBμV/m)	Margin (dB)
V	11160.000	54.5	33	40.8	62.3	74.0	-11.7
V	16740.000	54.4	33	37.6	59.0	68.0	-9.0
V	22320.000	53.9	33	38.2	59.1	74.0	-14.9
V	27900.000	53.5	33	40.0	60.5	68.0	-7.5
H	33480.000	54.0	33	40.8	61.8	68.0	-6.2

TEST REPORT

RADIATED EMISSION DATA

IEEE 802.11n (HT20MHz) (MCS0)

5700MHz

Polarization	Frequency (MHz)	Reading (dB μ V)	Pre-Amp Gain (dB)	Antenna Factor (dB)	Net at 3m - Average (dB μ V/m)	Average Factor (dB)	Calculated at 3m (dB μ V/m)	Average Limit at 3m (dB μ V/m)	Margin (dB)
V	11400.000	39.5	33	40.8	47.3	0	47.3	54.0	-6.7
V	17100.000	42.2	33	37.6	46.8	0	46.8	68.0	-21.2
H	22800.000	41.8	33	38.3	47.1	0	47.1	54.0	-6.9
V	28500.000	40.3	33	40.1	47.4	0	47.4	68.0	-20.6
V	34200.000	39.1	33	41.1	47.2	0	47.2	68.0	-20.8

Polarization	Frequency (MHz)	Reading (dB μ V)	Pre-Amp Gain (dB)	Antenna Factor (dB)	Net at 3m - Peak (dB μ V/m)	Peak Limit at 3m (dB μ V/m)	Margin (dB)
V	11400.000	53.8	33	40.8	61.6	74.0	-12.4
V	17100.000	56.4	33	37.6	61.0	68.0	-7.0
H	22800.000	55.9	33	38.3	61.2	74.0	-12.8
V	28500.000	54.6	33	40.1	61.7	68.0	-6.3
V	34200.000	53.7	33	41.1	61.8	68.0	-6.2

5745MHz

Polarization	Frequency (MHz)	Reading (dB μ V)	Pre-Amp Gain (dB)	Antenna Factor (dB)	Net at 3m - Average (dB μ V/m)	Average Factor (dB)	Calculated at 3m (dB μ V/m)	Average Limit at 3m (dB μ V/m)	Margin (dB)
V	11490.000	42.2	33	40.8	50.0	0	50.0	54.0	-4.0
V	17235.000	46.3	33	37.6	50.9	0	50.9	68.0	-17.1
V	22980.000	45.6	33	38.3	50.9	0	50.9	54.0	-3.1
H	28725.000	43.2	33	40.1	50.3	0	50.3	68.0	-17.7
V	34470.000	41.9	33	41.1	50.0	0	50.0	68.0	-18.0

Polarization	Frequency (MHz)	Reading (dB μ V)	Pre-Amp Gain (dB)	Antenna Factor (dB)	Net at 3m - Peak (dB μ V/m)	Peak Limit at 3m (dB μ V/m)	Margin (dB)
V	11490.000	57.6	33	40.8	65.4	74.0	-8.6
V	17235.000	62.4	33	37.6	67.0	68.0	-1.0
V	22980.000	61.0	33	38.3	66.3	74.0	-7.7
H	28725.000	59.5	33	40.1	66.6	68.0	-1.4
V	34470.000	58.0	33	41.1	66.1	68.0	-1.9

TEST REPORT

RADIATED EMISSION DATA

IEEE 802.11n (HT20MHz) (MCS0)

5785MHz

Polarization	Frequency (MHz)	Reading (dB μ V)	Pre-Amp Gain (dB)	Antenna Factor (dB)	Net at 3m - Average (dB μ V/m)	Average Factor (dB)	Calculated at 3m (dB μ V/m)	Average Limit at 3m (dB μ V/m)	Margin (dB)
V	11570.000	41.8	33	40.5	49.3	0	49.3	54.0	-4.7
V	17355.000	42.7	33	37.6	47.3	0	47.3	68.0	-20.7
H	23140.000	42.7	33	38.6	48.3	0	48.3	68.0	-19.7
V	28925.000	41.2	33	40.1	48.3	0	48.3	68.0	-19.7
H	34710.000	41.2	33	41.3	49.5	0	49.5	68.0	-18.5

Polarization	Frequency (MHz)	Reading (dB μ V)	Pre-Amp Gain (dB)	Antenna Factor (dB)	Net at 3m - Peak (dB μ V/m)	Peak Limit at 3m (dB μ V/m)	Margin (dB)
V	11570.000	55.8	33	40.5	63.3	74.0	-10.7
V	17355.000	56.2	33	37.6	60.8	68.0	-7.2
H	23140.000	57.9	33	38.6	63.5	68.0	-4.5
V	28925.000	55.1	33	40.1	62.2	68.0	-5.8
H	34710.000	54.5	33	41.3	62.8	68.0	-5.2

5825MHz

Polarization	Frequency (MHz)	Reading (dB μ V)	Pre-Amp Gain (dB)	Antenna Factor (dB)	Net at 3m - Average (dB μ V/m)	Average Factor (dB)	Calculated at 3m (dB μ V/m)	Average Limit at 3m (dB μ V/m)	Margin (dB)
V	11650.000	45.9	33	40.5	53.4	0	53.4	54.0	-0.6
V	17475.000	43.4	33	37.6	48.0	0	48.0	68.0	-20.0
V	23300.000	48.2	33	38.6	53.8	0	53.8	68.0	-14.2
H	29125.000	42.3	33	40.0	49.3	0	49.3	68.0	-18.7
V	34950.000	42.5	33	41.3	50.8	0	50.8	68.0	-17.2

Polarization	Frequency (MHz)	Reading (dB μ V)	Pre-Amp Gain (dB)	Antenna Factor (dB)	Net at 3m - Peak (dB μ V/m)	Peak Limit at 3m (dB μ V/m)	Margin (dB)
V	11650.000	63.1	33	40.5	70.6	74.0	-3.4
V	17475.000	56.9	33	37.6	61.5	68.0	-6.5
V	23300.000	57.9	33	38.6	63.5	68.0	-4.5
H	29125.000	59.6	33	40.0	66.6	68.0	-1.4
V	34950.000	56.1	33	41.3	64.4	68.0	-3.6

- Notes:
1. Peak detector is used for the emission measurement.
 2. All measurements were made at 3 meters.
 3. Negative value in the margin column shows emission below limit.
 4. Horn antenna is used for the emission over 1000MHz.
 5. Emissions within the restricted band meets the requirement of FCC Part 15 Section 15.205.
 6. Measurement Uncertainty is ± 5.3 dB at a level of confidence of 95%.
 7. For the measurement of radiated emission, summation method was used which numerical integrating (in terms of linear power) over the transmitter occupied bandwidth.
 8. For the linear power measurement, data in 1MHz spacing was collected by spectrum analyzer with 1MHz resolution bandwidth.
 9. Average detector is used according to ANSI C63.10 for average measurement.

TEST REPORT

RADIATED EMISSION DATA

IEEE 802.11n (40MHz) (MCS0)

5190MHz

Polarization	Frequency (MHz)	Reading (dBμV)	Pre-Amp Gain (dB)	Antenna Factor (dB)	Net at 3m - Average (dBμV/m)	Average Factor (dB)	Calculated at 3m (dBμV/m)	Average Limit at 3m (dBμV/m)	Margin (dB)
H	5150.000	40.5	33	35.7	43.2	0	43.2	54.0	-10.8
V	10380.000	39.3	33	40.5	46.8	0	46.8	68.0	-21.2
V	15570.000	41.8	33	37.7	46.5	0	46.5	54.0	-7.5
H	20760.000	43.2	33	37.7	47.9	0	47.9	54.0	-6.1
V	25950.000	41.3	33	39.3	47.6	0	47.6	68.0	-20.4
H	31140.000	38.6	33	42.1	47.7	0	47.7	68.0	-20.3

Polarization	Frequency (MHz)	Reading (dBμV)	Pre-Amp Gain (dB)	Antenna Factor (dB)	Net at 3m - Peak (dBμV/m)	Peak Limit at 3m (dBμV/m)	Margin (dB)
H	5150.000	56.1	33	35.7	58.8	74.0	-15.2
V	10380.000	53.4	33	40.5	60.9	68.0	-7.1
V	15570.000	55.4	33	37.7	60.1	74.0	-13.9
H	20760.000	56.4	33	37.7	61.1	74.0	-12.9
V	25950.000	55.1	33	39.3	61.4	68.0	-6.6
H	31140.000	52.8	33	42.1	61.9	68.0	-6.1

5230MHz

Polarization	Frequency (MHz)	Reading (dBμV)	Pre-Amp Gain (dB)	Antenna Factor (dB)	Net at 3m - Average (dBμV/m)	Average Factor (dB)	Calculated at 3m (dBμV/m)	Average Limit at 3m (dBμV/m)	Margin (dB)
V	10460.000	39.1	33	40.5	46.6	0	46.6	68.0	-21.4
H	15690.000	40.2	33	37.7	44.9	0	44.9	54.0	-9.1
V	20920.000	40.3	33	37.7	45.0	0	45.0	54.0	-9.0
V	26150.000	40.5	33	39.2	46.7	0	46.7	68.0	-21.3
V	31380.000	36.4	33	42.1	45.5	0	45.5	54.0	-8.5

Polarization	Frequency (MHz)	Reading (dBμV)	Pre-Amp Gain (dB)	Antenna Factor (dB)	Net at 3m - Peak (dBμV/m)	Peak Limit at 3m (dBμV/m)	Margin (dB)
V	10460.000	53.1	33	40.5	60.6	68.0	-7.4
H	15690.000	53.6	33	37.7	58.3	74.0	-15.7
V	20920.000	55.7	33	37.7	60.4	74.0	-13.6
V	26150.000	52.9	33	39.2	59.1	68.0	-8.9
V	31380.000	50.6	33	42.1	59.7	74.0	-14.3

TEST REPORT

RADIATED EMISSION DATA

IEEE 802.11n (40MHz) (MCS0)

5270MHz

Polarization	Frequency (MHz)	Reading (dBµV)	Pre-Amp Gain (dB)	Antenna Factor (dB)	Net at 3m - Average (dBµV/m)	Average Factor (dB)	Calculated at 3m (dBµV/m)	Average Limit at 3m (dBµV/m)	Margin (dB)
V	10540.000	41.7	33	40.4	49.1	0	49.1	68.0	-18.9
V	15810.000	39.9	33	37.7	44.6	0	44.6	54.0	-9.4
H	21080.000	42.5	33	37.9	47.4	0	47.4	54.0	-6.6
H	26350.000	38.9	33	39.2	45.1	0	45.1	68.0	-22.9
H	31620.000	39.0	33	40.4	46.4	0	46.4	54.0	-7.6

Polarization	Frequency (MHz)	Reading (dBµV)	Pre-Amp Gain (dB)	Antenna Factor (dB)	Net at 3m - Peak (dBµV/m)	Peak Limit at 3m (dBµV/m)	Margin (dB)
V	10540.000	55.3	33	40.4	62.7	68.0	-5.3
V	15810.000	53.1	33	37.7	57.8	74.0	-16.2
H	21080.000	55.5	33	37.9	60.4	74.0	-13.6
H	26350.000	56.4	33	39.2	62.6	68.0	-5.4
H	31620.000	54.4	33	40.4	61.8	74.0	-12.2

5310MHz

Polarization	Frequency (MHz)	Reading (dBµV)	Pre-Amp Gain (dB)	Antenna Factor (dB)	Net at 3m - Average (dBµV/m)	Average Factor (dB)	Calculated at 3m (dBµV/m)	Average Limit at 3m (dBµV/m)	Margin (dB)
H	5350.000	38.4	33	35.7	41.1	0	41.1	54.0	-12.9
V	10620.000	40.1	33	40.4	47.5	0	47.5	54.0	-6.5
V	15930.000	41.5	33	37.7	46.2	0	46.2	54.0	-7.8
H	21240.000	42.8	33	37.9	47.7	0	47.7	54.0	-6.3
V	26550.000	40.8	33	39.9	47.7	0	47.7	68.0	-20.3
V	31860.000	40.4	33	40.4	47.8	0	47.8	68.0	-20.2

Polarization	Frequency (MHz)	Reading (dBµV)	Pre-Amp Gain (dB)	Antenna Factor (dB)	Net at 3m - Peak (dBµV/m)	Peak Limit at 3m (dBµV/m)	Margin (dB)
H	5350.000	52.1	33	35.7	54.8	74.0	-19.2
V	10620.000	54.1	33	40.4	61.5	74.0	-12.5
V	15930.000	55.3	33	37.7	60.0	74.0	-14.0
H	21240.000	55.9	33	37.9	60.8	74.0	-13.2
V	26550.000	54.6	33	39.9	61.5	68.0	-6.5
V	31860.000	53.8	33	40.4	61.2	68.0	-6.8

TEST REPORT

RADIATED EMISSION DATA

IEEE 802.11n (40MHz) (MCS0)

5510MHz

Polarization	Frequency (MHz)	Reading (dBμV)	Pre-Amp Gain (dB)	Antenna Factor (dB)	Net at 3m - Average (dBμV/m)	Average Factor (dB)	Calculated at 3m (dBμV/m)	Average Limit at 3m (dBμV/m)	Margin (dB)
H	5470.000	38.2	33	35.7	40.9	0	40.9	68.0	-27.1
V	11020.000	39.9	33	40.8	47.7	0	47.7	54.0	-6.3
H	16530.000	41.0	33	37.6	45.6	0	45.6	68.0	-22.4
V	22040.000	40.9	33	38.2	46.1	0	46.1	54.0	-7.9
V	27550.000	39.5	33	40.0	46.5	0	46.5	68.0	-21.5
H	33060.000	39.3	33	40.8	47.1	0	47.1	68.0	-20.9

Polarization	Frequency (MHz)	Reading (dBμV)	Pre-Amp Gain (dB)	Antenna Factor (dB)	Net at 3m - Peak (dBμV/m)	Peak Limit at 3m (dBμV/m)	Margin (dB)
H	5470.000	52.1	33	35.7	54.8	68.0	-13.2
V	11020.000	53.6	33	40.8	61.4	74.0	-12.6
H	16530.000	54.5	33	37.6	59.1	68.0	-8.9
V	22040.000	55.4	33	38.2	60.6	74.0	-13.4
V	27550.000	53.3	33	40.0	60.3	68.0	-7.7
H	33060.000	53.5	33	40.8	61.3	68.0	-6.7

5550MHz

Polarization	Frequency (MHz)	Reading (dBμV)	Pre-Amp Gain (dB)	Antenna Factor (dB)	Net at 3m - Average (dBμV/m)	Average Factor (dB)	Calculated at 3m (dBμV/m)	Average Limit at 3m (dBμV/m)	Margin (dB)
V	11100.000	41.9	33	40.8	49.7	0	49.7	54.0	-4.3
V	16650.000	38.9	33	37.6	43.5	0	43.5	68.0	-24.5
H	22200.000	42.3	33	38.2	47.5	0	47.5	54.0	-6.5
V	27750.000	38.7	33	40.0	45.7	0	45.7	68.0	-22.3
H	33300.000	40.7	33	40.8	48.5	0	48.5	68.0	-19.5

Polarization	Frequency (MHz)	Reading (dBμV)	Pre-Amp Gain (dB)	Antenna Factor (dB)	Net at 3m - Peak (dBμV/m)	Peak Limit at 3m (dBμV/m)	Margin (dB)
V	11100.000	55.9	33	40.8	63.7	74.0	-10.3
V	16650.000	52.6	33	37.6	57.2	68.0	-10.8
H	22200.000	54.7	33	38.2	59.9	74.0	-14.1
V	27750.000	56.8	33	40.0	63.8	68.0	-4.2
H	33300.000	54.6	33	40.8	62.4	68.0	-5.6

TEST REPORT

RADIATED EMISSION DATA

IEEE 802.11n (40MHz) (MCS0)

5670MHz

Polarization	Frequency (MHz)	Reading (dBμV)	Pre-Amp Gain (dB)	Antenna Factor (dB)	Net at 3m - Average (dBμV/m)	Average Factor (dB)	Calculated at 3m (dBμV/m)	Average Limit at 3m (dBμV/m)	Margin (dB)
H	11340.000	38.4	33	40.8	46.2	0	46.2	54.0	-7.8
H	17010.000	38.8	33	37.6	43.4	0	43.4	68.0	-24.6
V	22680.000	41.2	33	38.3	46.5	0	46.5	54.0	-7.5
H	28350.000	38.8	33	40.0	45.8	0	45.8	68.0	-22.2
V	34020.000	38.0	33	41.1	46.1	0	46.1	68.0	-21.9

Polarization	Frequency (MHz)	Reading (dBμV)	Pre-Amp Gain (dB)	Antenna Factor (dB)	Net at 3m - Peak (dBμV/m)	Peak Limit at 3m (dBμV/m)	Margin (dB)
H	11340.000	51.5	33	40.8	59.3	74.0	-14.7
H	17010.000	52.4	33	37.6	57.0	68.0	-11.0
V	22680.000	54.5	33	38.3	59.8	74.0	-14.2
H	28350.000	51.9	33	40.0	58.9	68.0	-9.1
V	34020.000	50.4	33	41.1	58.5	68.0	-9.5

5755MHz

Polarization	Frequency (MHz)	Reading (dBμV)	Pre-Amp Gain (dB)	Antenna Factor (dB)	Net at 3m - Average (dBμV/m)	Average Factor (dB)	Calculated at 3m (dBμV/m)	Average Limit at 3m (dBμV/m)	Margin (dB)
V	11510.000	39.7	33	40.5	47.2	0	47.2	54.0	-6.8
V	17265.000	42.2	33	37.6	46.8	0	46.8	68.0	-21.2
H	23020.000	41.6	33	38.6	47.2	0	47.2	54.0	-6.8
V	28775.000	40.6	33	40.1	47.7	0	47.7	68.0	-20.3
H	34530.000	39.6	33	41.3	47.9	0	47.9	68.0	-20.1

Polarization	Frequency (MHz)	Reading (dBμV)	Pre-Amp Gain (dB)	Antenna Factor (dB)	Net at 3m - Peak (dBμV/m)	Peak Limit at 3m (dBμV/m)	Margin (dB)
V	11510.000	53.7	33	40.5	61.2	74.0	-12.8
V	17265.000	55.6	33	37.6	60.2	68.0	-7.8
H	23020.000	55.4	33	38.6	61.0	74.0	-13.0
V	28775.000	54.0	33	40.1	61.1	68.0	-6.9
H	34530.000	52.8	33	41.3	61.1	68.0	-6.9

TEST REPORT

RADIATED EMISSION DATA

IEEE 802.11n (40MHz) (MCS0)

5795MHz

Polarization	Frequency (MHz)	Reading (dB μ V)	Pre-Amp Gain (dB)	Antenna Factor (dB)	Net at 3m - Average (dB μ V/m)	Average Factor (dB)	Calculated at 3m (dB μ V/m)	Average Limit at 3m (dB μ V/m)	Margin (dB)
V	11590.000	42.3	33	40.5	49.8	0	49.8	54.0	-4.2
H	17385.000	42.6	33	37.6	47.2	0	47.2	68.0	-20.8
V	23180.000	44.2	33	38.6	49.8	0	49.8	68.0	-18.2
H	28975.000	42.0	33	40.1	49.1	0	49.1	68.0	-18.9
V	34770.000	40.8	33	41.3	49.1	0	49.1	68.0	-18.9

Polarization	Frequency (MHz)	Reading (dB μ V)	Pre-Amp Gain (dB)	Antenna Factor (dB)	Net at 3m - Peak (dB μ V/m)	Peak Limit at 3m (dB μ V/m)	Margin (dB)
V	11590.000	56.2	33	40.5	63.7	74.0	-10.3
H	17385.000	56.5	33	37.6	61.1	68.0	-6.9
V	23180.000	56.9	33	38.6	62.5	68.0	-5.5
H	28975.000	56.3	33	40.1	63.4	68.0	-4.6
V	34770.000	54.5	33	41.3	62.8	68.0	-5.2

- Notes:
1. Peak detector is used for the emission measurement.
 2. All measurements were made at 3 meters.
 3. Negative value in the margin column shows emission below limit.
 4. Horn antenna is used for the emission over 1000MHz.
 5. Emissions within the restricted band meets the requirement of FCC Part 15 Section 15.205.
 6. Measurement Uncertainty is ± 5.3 dB at a level of confidence of 95%.
 7. For the measurement of radiated emission, summation method was used which numerical integrating (in terms of linear power) over the transmitter occupied bandwidth.
 8. For the linear power measurement, data in 1MHz spacing was collected by spectrum analyzer with 1MHz resolution bandwidth.
 9. Average detector is used according to ANSI C63.10 for average measurement.

TEST REPORT**RADIATED EMISSION DATA**

Mode: 5GHz Wi-Fi and BLE Operating

Polarization	Frequency (MHz)	Reading (dB μ V)	Pre-amp (dB)	Antenna Factor (dB)	Net at 3m (dB μ V/m)	Limit at 3m (dB μ V/m)	Margin (dB)
H	159.980	39.7	16	16.0	39.7	43.5	-3.8
H	216.604	26.0	16	17.0	27.0	46.0	-19.0
H	320.030	29.7	16	23.0	36.7	46.0	-9.3
V	675.050	26.9	16	29.0	39.9	46.0	-6.1
H	720.276	19.4	16	30.0	33.4	46.0	-12.6
V	960.230	17.3	16	33.0	34.3	54.0	-19.7

- Notes:
1. Peak detector is used for the emission measurement.
 2. All measurements were made at 3 meters.
 3. Negative value in the margin column shows emission below limit.
 4. Emissions within the restricted band meets the requirement of FCC Part 15 Section 15.205 / RSS-Gen Section 8.10.
 5. Measurement Uncertainty is ± 5.3 dB at a level of confidence of 95%.

TEST REPORT

3.7 AC Power Line Conducted Emission

- Not Applicable – EUT is only powered by battery for operation.
- EUT connects to AC power line. Emission Data is listed in following pages.
- Base Unit connects to AC power line and has transmission. Handset connects to AC power line but has no transmission. Emission Data of Base Unit is listed in following pages.

3.7.1 AC Power Line Conducted Emission Configuration Photograph

The worst case line conducted configuration photographs are attached in the Appendix and saved with filename: config photos.pdf.

3.7.2 AC Power Line Conducted Emission Data

The plot(s) and data in the following pages list the significant emission frequencies, the limit and the margin of compliance.

Passed by over 20 dB margin.

3.7.3 Conducted Emission Test Setup

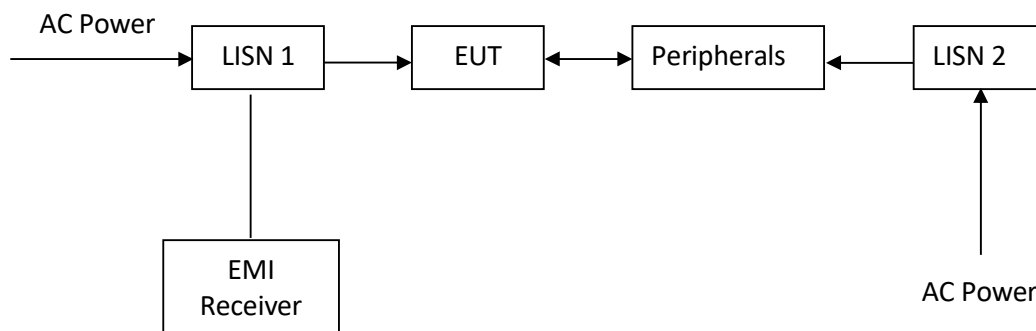

The EUT along with its peripherals were placed on a 1.0m(W)×1.5m(L) and 0.8m in height wooden table and the EUT was adjusted to maintain a 0.4 meter space from a vertical reference plane. The EUT was connected to power mains through a line impedance stabilization network (LISN), which provided 50 ohm coupling impedance for measuring instrument and the chassis ground was bounded to the horizontal ground plane of shielded room. The excess power cable between the EUT and the LISN was bundled.

All connecting cables of EUT and peripherals were moved to find the maximum emission.

TEST REPORT

AC POWER LINE CONDUCTED EMISSION

Worst Case Operating Mode: 5GHz Wi-Fi and BLE Operating

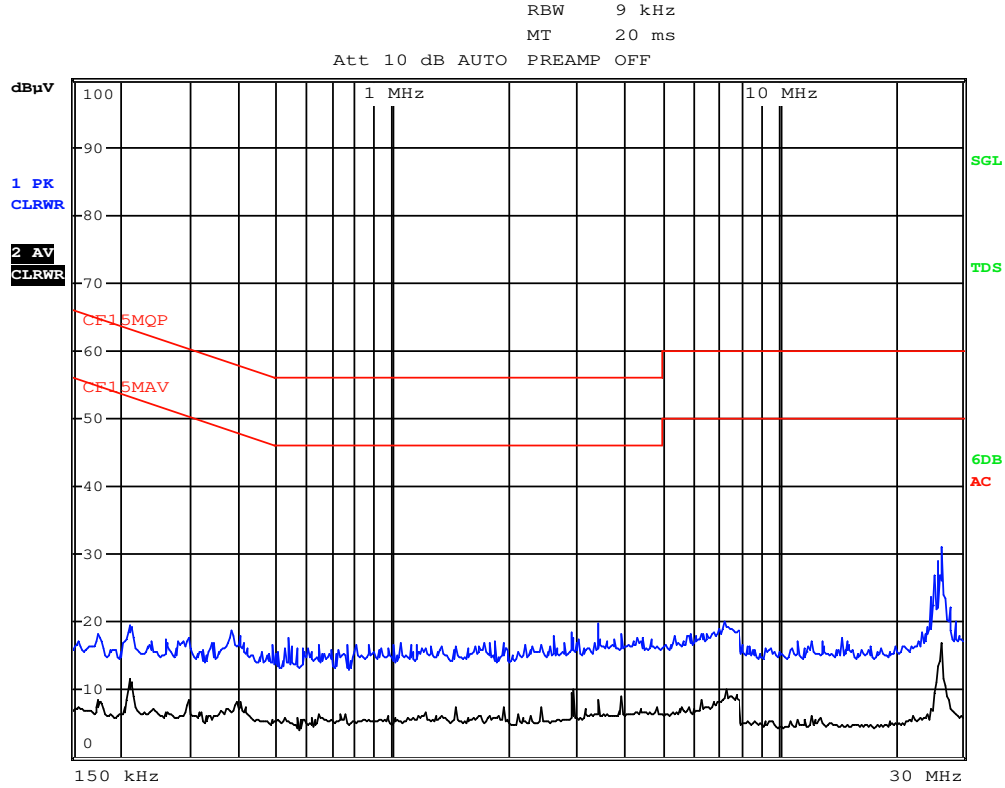

TEST REPORT

3.8 Frequency Stability Requirement

Frequency (MHz)	Mode	Measured Value (ppm) (0°C)	Measured Value (ppm) (10°C)	Measured Value (ppm) (20°C)	Measured Value (ppm) (30°C)	Measured Value (ppm) (40°C)	Measured Value (ppm) (50°C)
5180	A	0.822	0.958	4.066	4.180	3.960	3.713
5260		0.799	0.862	4.038	4.125	3.848	3.654
5500		0.759	0.835	4.033	4.295	3.776	3.655
5745		0.756	0.847	4.099	4.877	3.844	4.253

Temperature (°C)	Frequency (MHz)	Mode	Measured Value (ppm) 120VAC	Measured Value (ppm) 138VAC	Measured Value (ppm) 102VAC
25	5180	A	4.055	4.676	3.907
25	5260		3.990	4.664	3.550
25	5500		3.932	4.865	3.515
25	5745		4.142	3.581	4.499

The Maximum value is +4.877 ppm.

It is proved that the frequency stability such that an emission is maintained within the band of operation under all condition.

3.9 U-NII-1 99% Bandwidth Requirement

For the case if a channel operating in U-NII-1 band has a 26-dB bandwidth that straddles into U-NII-2A band but its 99% occupied power bandwidth does not. For this rare case, DFS requirement does not apply.

The plots of U-NII-1 99% bandwidth is saved with filename: DATA.pdf proved that no further test for DFS.

TEST REPORT

3.10 Dynamic Frequency Selection (DFS)

According to standard 905462 DO2 UNII DFS Compliance Procedures New Rules v02 Section 5.1.1 and 5.1.2.

3.10.1 Master Devices

- a) The Master Device will use DFS in order to detect Radar Waveforms with received signal strength above the DFS Detection Threshold in the 5250 - 5350 MHz and 5470- 5725 MHz bands. DFS is not required in the 5150 - 5250 MHz or 5725 - 5825 MHz bands.
- b) Before initiating a network on a Channel, the Master Device will perform a Channel Availability Check for a specified time duration (Channel Availability Check Time) to ensure that there is no radar system operating on the Channel, using DFS described under subsection a) above.
- c) The Master Device initiates a U-NII network by transmitting control signals that will enable other U-NII devices to Associate with the Master Device.
- d) During normal operation, the Master Device will monitor the Channel (In-Service Monitoring) to ensure that there is no radar system operating on the Channel, using DFS described under a).
- e) If the Master Device has detected a Radar Waveform during In-Service Monitoring as described under d), the Operating Channel of the U-NII network is no longer an Available Channel. The Master Device will instruct all associated Client Device(s) to stop transmitting on this Channel within the Channel Move Time. The transmissions during the Channel Move Time will be limited to the Channel Closing Transmission Time.
- f) Once the Master Device has detected a Radar Waveform it will not utilize the Channel for the duration of the Non-Occupancy Period.
- g) If the Master Device delegates the In-Service Monitoring to a Client Device, then the combination will be tested to the requirements described under d) through f) above.

3.10.2 Client Devices

- a) A Client Device will not transmit before having received appropriate control signals from a Master Device.
- b) A Client Device will stop all its transmissions whenever instructed by a Master Device to which it is associated and will meet the Channel Move Time and Channel Closing Transmission Time requirements. The Client Device will not resume any transmissions until it has again received control signals from a Master Device.
- c) If a Client Device is performing In-Service Monitoring and detects a Radar Waveform above the DFS Detection Threshold, it will inform the Master Device. This is equivalent to the Master Device detecting the Radar Waveform and d) through f) of section 5.1.1 apply.
- d) Irrespective of Client Device or Master Device detection the Channel Move Time and Channel Closing Transmission Time requirements remain the same.
- e) The client test frequency must be monitored to ensure no transmission of any type has occurred for 30 minutes. Note: If the client moves with the master, the device is considered compliant if nothing appears in the client non-occupancy period test. For devices that shut down (rather than moving channels), no beacons should appear.

TEST REPORT

Applicability of DFS Requirement During Normal Operation

Requirement	Operational Mode	
	Master Device or Client with Radar Detection	Client Without Radar Detection
<i>DFS Detection Threshold</i>	Yes	Not required
<i>Channel Closing Transmission Time</i>	Yes	Yes
<i>Channel Move Time</i>	Yes	Yes
<i>U-NII Detection Bandwidth</i>	Yes	Not required

Additional requirements for devices with multiple bandwidth modes	Master Device or Client with Radar Detection	Client Without Radar Detection
<i>U-NII Detection Bandwidth and Statistical Performance Check</i>	All BW modes must be tested	Not required
<i>Channel Move Time and Channel Closing Transmission Time</i>	Test using widest BW mode available	Test using the widest BW mode available for the link
<i>All other tests</i>	Any single BW mode	Not required
Note: Frequencies selected for statistical performance check (Section 7.8.4) should include several frequencies within the radar detection bandwidth and frequencies near the edge of the radar detection bandwidth. For 802.11 devices it is suggested to select frequencies in each of the bonded 20 MHz channels and the channel center frequency.		

The operational behavior and individual DFS requirements that are associated with these modes are as follows:

TEST REPORT

Response Requirements

Parameter	Value
<i>Non-occupancy period</i>	Minimum 30 minutes
<i>Channel Availability Check Time</i>	60 seconds
<i>Channel Move Time</i>	10 seconds See Note 1.
<i>Channel Closing Transmission Time</i>	200 milliseconds + an aggregate of 60 milliseconds over remaining 10 second period. See Notes 1 and 2.
<i>U-NII Detection Bandwidth</i>	Minimum 100% of the U-NII 99% transmission power bandwidth. See Note 3.
<p>Note 1: <i>Channel Move Time</i> and the <i>Channel Closing Transmission Time</i> should be performed with Radar Type 0. The measurement timing begins at the end of the Radar Type 0 burst.</p> <p>Note 2: The <i>Channel Closing Transmission Time</i> is comprised of 200 milliseconds starting at the beginning of the <i>Channel Move Time</i> plus any additional intermittent control signals required to facilitate a <i>Channel</i> move (an aggregate of 60 milliseconds) during the remainder of the 10 second period. The aggregate duration of control signals will not count quiet periods in between transmissions.</p> <p>Note 3: During the <i>U-NII Detection Bandwidth</i> detection test, radar type 0 should be used. For each frequency step the minimum percentage of detection is 90 percent. Measurements are performed with no data traffic.</p>	

TEST REPORT

3.11 Short Pulse Radar Test Waveforms

Radar Type	Pulse Width (μsec)	PRI (μsec)	Number of Pulses	Minimum Percentage of Successful Detection	Minimum Number of Trials
0	1	1428	18	See Note 1	See Note 1
1	1	Test A: 15 unique PRI values randomly selected from the list of 23 PRI values in Table 5a	$\text{Roundup} \left\{ \left(\frac{1}{360} \right), \left(\frac{19 \cdot 10^6}{\text{PRI}_{\mu\text{sec}}} \right) \right\}$	60%	30
		Test B: 15 unique PRI values randomly selected within the range of 518-3066 μsec, with a minimum increment of 1 μsec, excluding PRI values selected in Test A			
2	1-5	150-230	23-29	60%	30
3	6-10	200-500	16-18	60%	30
4	11-20	200-500	12-16	60%	30
Aggregate (Radar Types 1-4)				80%	120
Note 1: Short Pulse Radar Type 0 should be used for the detection bandwidth test, channel move time, and channel closing time tests.					

TEST REPORT

3.12 Calibration Setup and DFS Test Results

3.12.1 Calibration Procedure of Radar Waveform:

The Interference Radar Detection Threshold Level is $-62\text{dBm} + 0\text{dBi} + 1\text{dB} = -61\text{dBm}$ that had been taken into account the output power range and antenna gain. The following equipment setup was used to calibrate the conducted Radar Waveform. A vector signal generator was utilized to establish the test signal level for radar type 0. During this process there were no transmissions by either the Master or client device. The Spectrum analyzer was switched was used. The spectrum analyzer resolution bandwidth (RBW) and video bandwidth (VBW) were set to 1MHz or 3MHz respectively to measure the type 0 radar waveform. The spectrum analyzer had offset to compensate and RF cable loss. The vector signal generator amplitude was set so that the power level measured at the spectrum analyzer was -61dBm . Capture the spectrum analyzer plots on short pulse radar waveform.

3.12.2 Conducted Setup

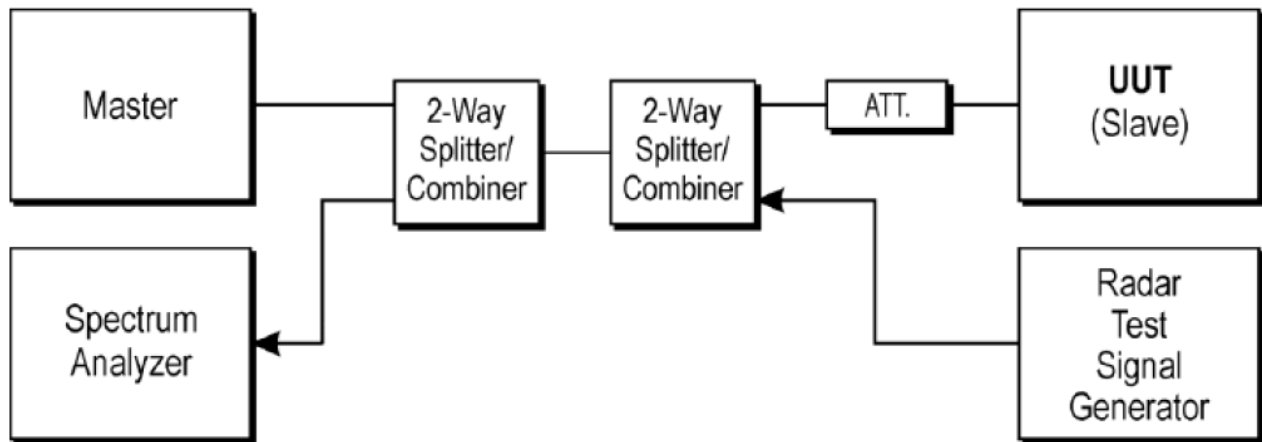

TEST REPORT

3.12.3 Radar Waveform Calibration Result

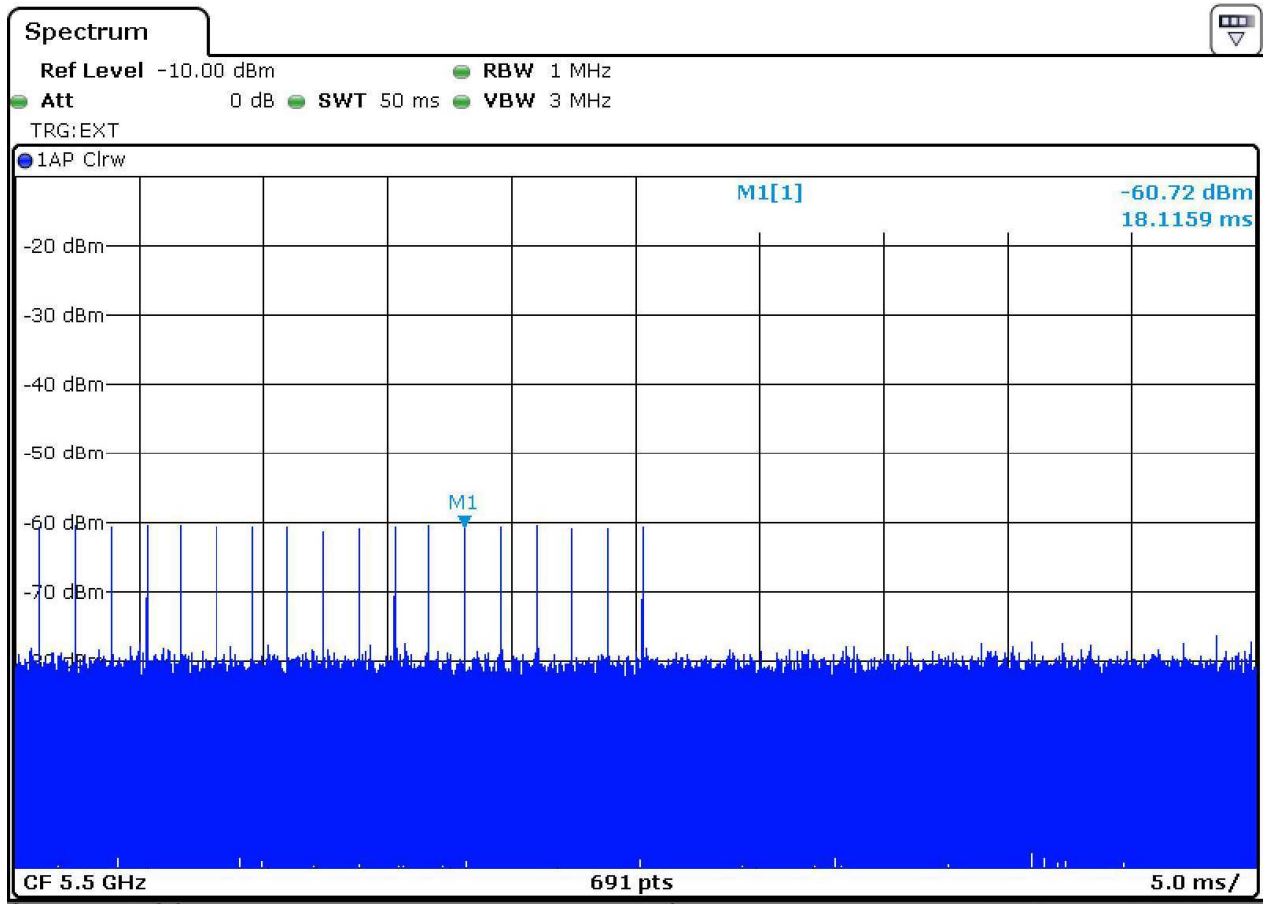

3.12.4 Test Deviation

There is no deviation with the original standard.

TEST REPORT

3.13.1 Test Procedures

1. The radar pulse generator is setup to provide a pulse at frequency that the Master and Client are operating. A type 0 radar pulse with a 1us pulse width and a 1428 us PRI is used for the testing.
2. The vector signal generator is adjusted to provide the radar burst (18 pules) at a level approximately -62dBm at the antenna of the Master device.
3. An external trigger is provided from the pulse generator to the DFS monitoring system in order to capture the traffic and the occurrence of the radar pulse.
4. A U-NII device operating as a Client Device (EUT) will associate with the Master at same channel. The MEPEG file "TestFile.mpg" specified by the FCC is streamed from the "file computer" through the master to the client device (EUT).
5. When a radar burst with a level equal to the DFS Detection Threshold + 1dB is generated on the operating Channel of the U-NII device. At time T0 the Radar Waveform generator sends a Burst of pulse of the radar waveform at Detection Threshold +1dB.
6. Observe the transmission of the EUT at the end of the radar Burst on the Operating Channel. Measure and record the transmissions from the EUT during the observation time. One 20seconds plot is reported for the short pulse Radar Type 0. The plot for the short pulse radar types start at the end if the radar burst.
7. Measurement of the aggregate duration of the Channel Closing Transmission Time method:
Center Frequency: operating frequency
Span: Zero
RBW: 1MHz
VBW: 3MHz
Sweep Time: 32Sec
Detector: Max Peak
Sweep: Single.
8. Measure the EUT for more than 30mintes following the Channel move time to verify the no transmission or beacons occur on this Channel.

3.13.2 Test Setup

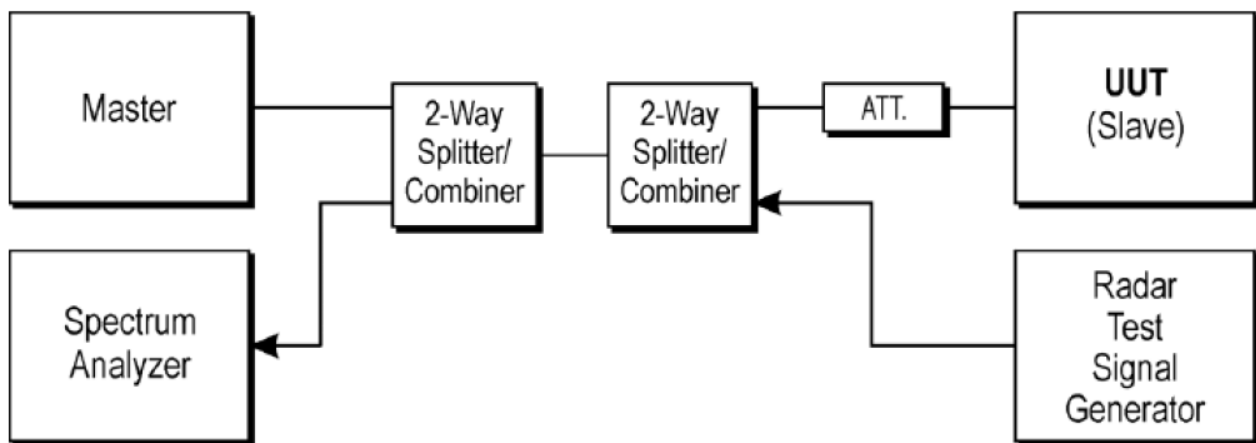

3.13.3 Test Deviation

There is no deviation with the original standard.

TEST REPORT

3.13.4 Test Result

Mode: 802.11n (HT40MHz)

Measurement Summary

DUT Frequency (MHz)	Radar Type No.	Type of Measurement value	Overall Result
5510.000000	0	Channel Move Time	PASS
5510.000000	0	Channel Closing Transmission Time	PASS

Channel Move Time Detailed Results

DUT Frequency (MHz)	Radar Type No.	CMT Tx Time (s)	CMT Limit (s)	CMT Result
5510.000000	0	2.249	10.000	PASS

Channel Closing Transmission Time Detailed Results

DUT Frequency (MHz)	Radar Type No.	CCTT Type of Value	CCTT No. of Pulses found	CCTT Tx Time (ms)
5510.000000	0	first 200 ms	0	0.000
5510.000000	0	remaining 10.0 second(s) period	4	0.244

(continuation of the "Channel Closing Transmission Time Detailed Results" table from column 5 ...)

DUT Frequency (MHz)	CCTT Tx Time Limit (ms)	CCTT Result
5510.000000	200.000	PASS
5510.000000	60.000	PASS

TEST REPORT

Channel Move Time

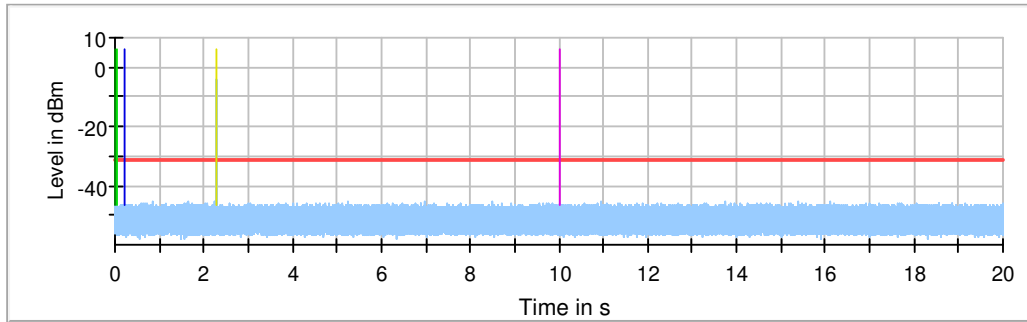

- Channel Move Time
- Threshold
- Start of Radar
- Trigger at end of Radar
- First 200ms of Channel Closing Tx Time
- 10sec Channel Move Time Limit
- Last measured edge of Channel Closing Tx Time

Channel Move Time first 200ms

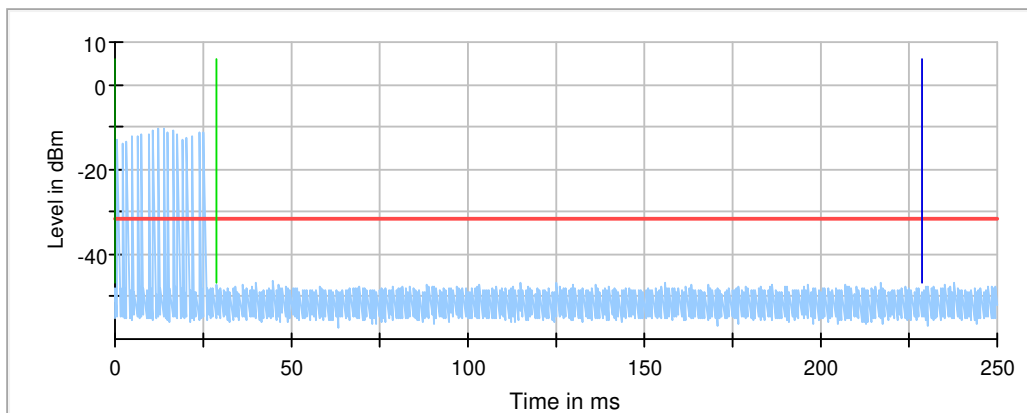

- Channel Move Time first 200ms
- Start of Radar
- First 200ms of Channel Closing Tx Time
- Threshold
- Trigger at end of Radar

TEST REPORT

EXHIBIT 4 EQUIPMENT LIST

1) Radiated Emissions Test

Equipment	EMI Test Receiver (9kHz to 26.5GHz)	Biconical Antenna (30MHz to 300MHz)	Log Periodic Antenna
Registration No.	EW-3156	EW-3242	EW-3243
Manufacturer	ROHDESCHWARZ	EMCO	EMCO
Model No.	ESR26	3110C	3148B
Calibration Date	May 02, 2025	July 30, 2024	July 30, 2024
Calibration Due Date	May 02, 2026	July 30, 2026	January 30, 2026

Equipment	Double Ridged Guide Antenna (1GHz - 18GHz)	Active Loop Antenna (H-field) (9kHz to 30MHz)	RF Preamplicifier (9kHz to 6000MHz)
Registration No.	EW-0194	EW-3326	EW-3006b
Manufacturer	EMCO	EMCO	SCHWARZBECK
Model No.	3115	6502	BBV9718
Calibration Date	May 10, 2023	January 05, 2024	October 20, 2023
Calibration Due Date	August 10, 2025	July 05, 2025	July 20, 2025

Equipment	5GHz Notch Filter	14m Double Shield RF Cable (9kHz - 6GHz)	RF Cable 14m (1GHz to 26.5GHz)
Registration No.	EW-3437	EW-2376	EW-2781
Manufacturer	MICROWAVE	RADIALL	GREATBILLION
Model No.	N1255031	n m/br56/bnc m 14m	SMA m/SHF5MPU /SMA m ra14m,26G
Calibration Date	December 25, 2024	September 19, 2023	January 16, 2024
Calibration Due Date	December 25, 2025	June 19, 2025	July 16, 2025

Equipment	12 metre RF Cable (1-40)GHz	Pyramidal Horn Antenna
Registration No.	EW-2774	EW-0905
Manufacturer	GREATBILLION	EMCO
Model No.	SMA m-m ra 12m 40G outdoor	3160-09
Calibration Date	January 16, 2024	December 15, 2023
Calibration Due Date	July 16, 2025	June 15, 2025

TEST REPORT

EXHIBIT4 EQUIPMENT LIST (CONT'D)

2) Conducted Emissions Test

Equipment	RF Cable 240cm (RG142) - (9kHz to 30MHz)	Artificial Mains Network	EMI Test Receiver (9kHz to 3GHz)
Registration No.	EW-2454	EW-3360	EW-3095
Manufacturer	RADIALL	ROHDESCHWARZ	ROHDESCHWARZ
Model No.	bnc m st / 142 /bnc m ra 240cm	ENV-216	ESCI
Calibration Date	June 20, 2024	April 07, 2024	January 18, 2024
Calibration Due Date	June 20, 2025	July 07, 2025	July 18, 2025

3) Conductive Measurement Test

Equipment	RF Power Meter with Power Sensor (N1921A)	Signal and Spectrum Analyzer (10Hz to 40GHz)
Registration No.	EW-3309	EW-3281
Manufacturer	ROHDESCHWARZ	ROHDESCHWARZ
Model No.	NRP-Z81	FSV40
Calibration Date	January 23, 2024	June 06, 2024
Calibration Due Date	July 23, 2025	June 06, 2025

4) Control Software for Radiated Emission

Software Information	
Software Name	EMC32
Manufacturer	ROHDESCHWARZ
Software version	10.50.40

END OF TEST REPORT